

YASKAWA

GENERAL-PURPOSE INVERTER WITH ADVANCED VECTOR CONTROL Varispeed G7

200 V CLASS 0.4 TO 110 kW (1.2 TO 160 kVA)
400 V CLASS 0.4 TO 300 kW (1.4 TO 460 kVA)



DMC

Drives Motors Controls

*3-Level
Control Method*

Certified for
ISO9001 and
ISO14001



JQA-QMA14913 JQA-EM0202

It's Common Sense

Introducing the New Global Standard: 3-Level Control

Yaskawa Electric is proud to announce the Varispeed G7, the first general-purpose Inverter in the world to feature the 3-level control method.

This new control technique solves the problem of microsurgers, and makes it possible to use the Varispeed G7 on existing motors.

The high performance and functionality provided by current vector control means powerful and high-precision operation for a diverse range of equipment and machinery.

The Varispeed G7 not only lowers your initial cost, but will dramatically slash your running costs through energy-saving control performance.

DIMC

World's First

3-Level Drives Motors Controls Control Method



Varispeed G7

CONTENTS

Features	4
Digital Operator.....	10
Standard Specifications	12
Software Functions	14
Connection Diagram and Terminal Functions	16
Dimensions	18
Mounting to a Fully-Enclosed Panel	20
Constants List	22
Constant Descriptions	30
Application Examples.....	56
Protective Functions	60
Typical Connection Diagrams	64
Options, Peripheral Devices.....	67
Notes.....	96
Supplements	102
Global Service Network.....	105

DMG

Drives Motors Controls

FEATURES

An Inverter designed for all the usage environments of the world

The Varispeed G7 has significantly reduced possible side effects on motors and power supplies. All of the complexities of switching to an Inverter have been resolved, making it possible to quickly and easily upgrade your equipment.

It's compliant with major international standards and networks, so it can be used anywhere.

- The solution to 400V class Inverter drive problems
- Global specifications
- Gentle on the environment

Varispeed G7

Drives Motors Controls



High-performance Inverters designed for ease of use

The Varispeed G7 offers high performance and powerful functions.

The extensive software library handles custom specifications quickly, and the entire system is designed to be user-friendly from setup through maintenance.

- High-level control performance
- User-friendly
- Easy to make exclusive Inverter

APPLICATIONS

Industrial machinery

Paper manufacturing machines



High-speed, high-precision newspaper rotary presses



High-precision speed and torque control on winding machines

Transportation



Quick response and high-precision positioning in stacker cranes

Fans and pumps



High-efficiency pump flow control

Metal machining Tools



For intelligent buildings (air conditioners, elevator doors, etc.)



For machining center spindles

Consumer equipment

Public facilities



Accurate water flow control for whirlpool baths

Medical equipment



X-ray equipment requiring quiet, smooth motion

Food processing machines



Improving quality with high torque in filling machines



Safe, smooth monorail transport

Living environment



Commercial washing machine

The solution to 400V class Inverter drive problems

The first 400V class general-purpose Inverter in the world to use the 3-level control method, to approach sine wave output voltage. It provides the solution to problems like motor insulation damage due to surge voltage, and electrolytic corrosion of motor bearings due to shaft voltage. Existing general-purpose motors can be used even without surge suppression filters. The noise and leakage current are greatly reduced (halved in in-house comparison).

Features of the 3-level control method

1 Low surge voltage

Suppresses surge voltage to the motor, eliminating the need for surge voltage protection for the motor.

2 Low electrical noise

Significantly reduces conduction (power supply) noise and radiated noise caused by Inverter drives, minimizing effects on peripheral devices.

3 Low acoustic noise

Provides low acoustic noise, difficult to achieve with conventional designs.

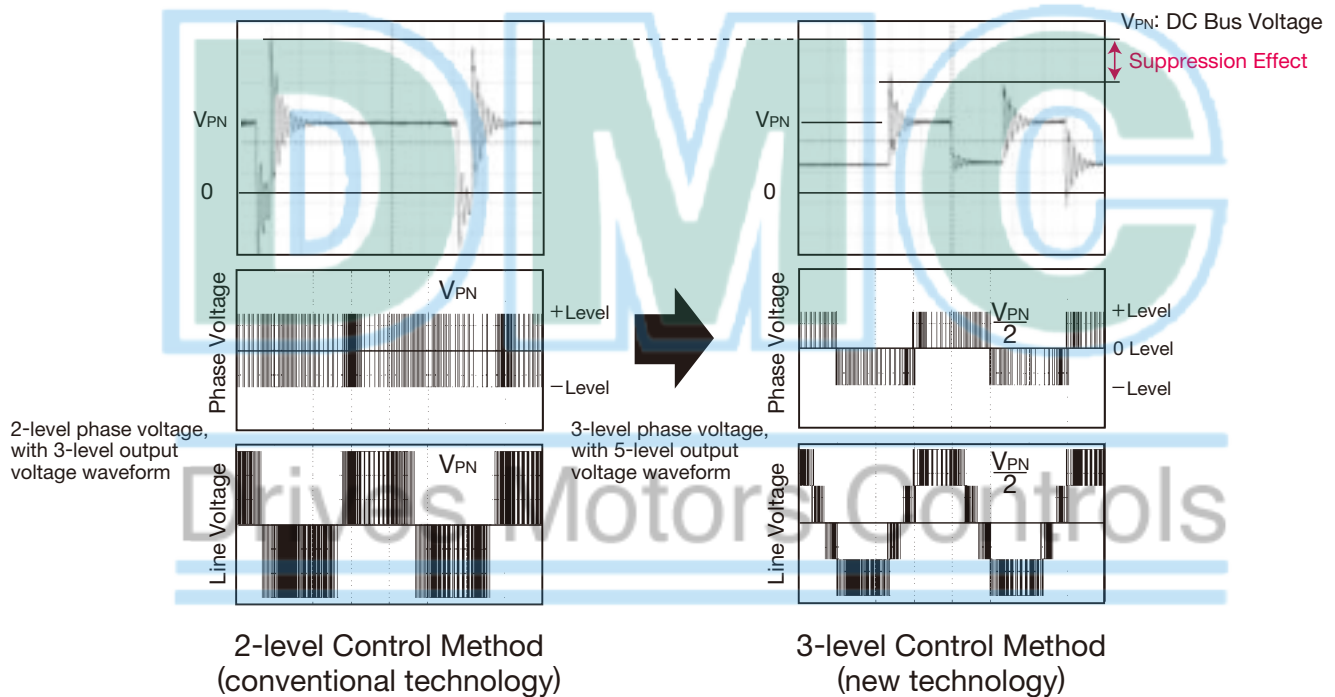
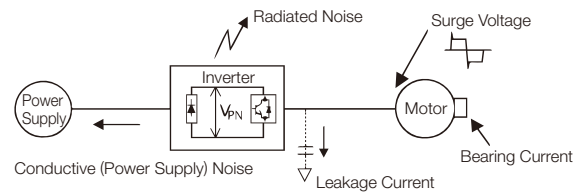

Gentle on the environment

Extensive energy-saving control

The energy-saving control approaches the maximum efficiency. High-efficient, energy-saving operations are achieved for any application either in vector control or V/f control.

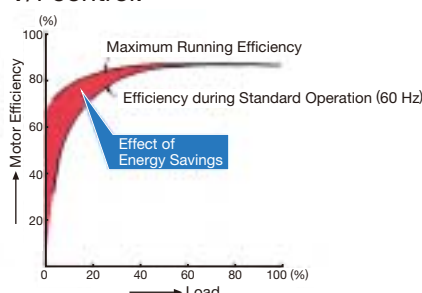

Countermeasures to minimize harmonics current

All models of 18.5 kW or more come equipped with DC reactors to improve the power factor, and support 12-pulse input (Note).

6-pulse input without AC reactor (conventional model)
Current distortion factor: 88%

12-pulse input with optical transformer with a dual star-delta secondary
Current distortion factor: 12%

Note: For 12-pulse input, a transformer with a star-delta secondary is required for the input power supply.

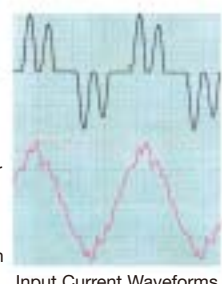

Global Specifications

Supporting global field networks

All models are fully compliant with RS-422/485 (MEMOBUS/Modbus protocol) standards. The networks are available by using communications option cards. Now you can connect to hosts and PLC, implement centralized management of production equipment and reduce wiring easily.

Digital operator with support for seven languages

The LCD panel digital operator that is included as standard equipment supports seven languages: Japanese (katakana), English, German, French, Italian, Spanish, and Portuguese.

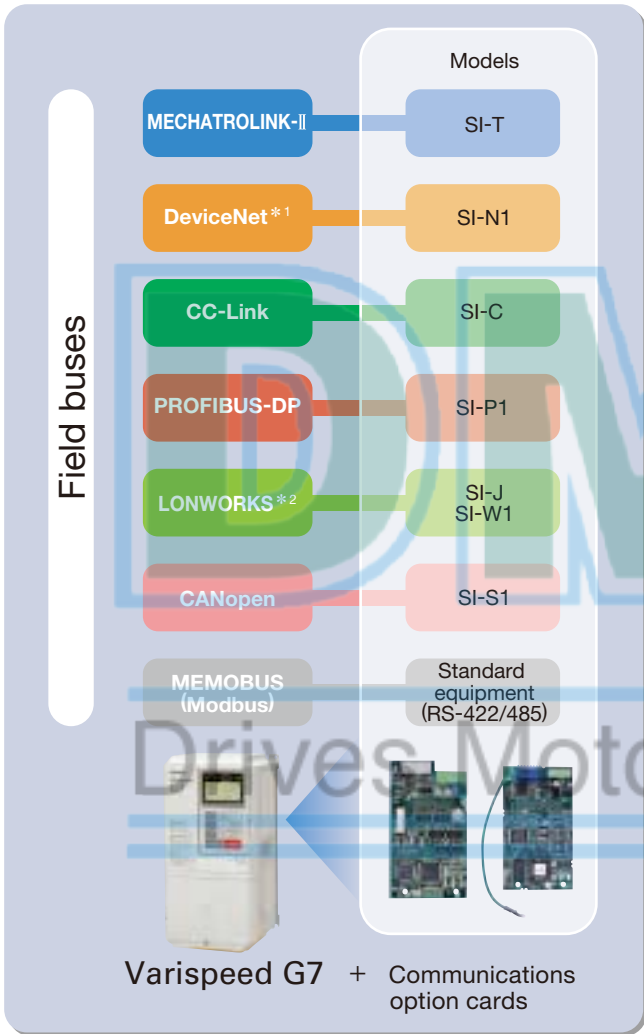

Global standards

Certification received: UL/cUL, CE marking, and KC marking



Various power supplies

Meets a variety of world power supply
 Three-phase 200 V series (200 to 240 V)
 Three-phase 400 V series (380 to 480 V)
 DC power supplies such as common converters are also available.

Global service

Our service networks cover U.S.A., Europe, China, South East Asia, and other parts of the world, and provide support for your business abroad.

*1: DeviceNet is a registered trademark of Open DeviceNet Vendors Association.
 *2: LONWORKS is a registered trademark of Echelon Corp.

High-level control performance

Outstanding torque characteristics

- The new observer (patent pending) improves torque characteristics (150%/0.3 Hz for open loop vector control 2) to provide high power for every machine. With PG, more than 150% high-torque operation is possible even at zero speed.

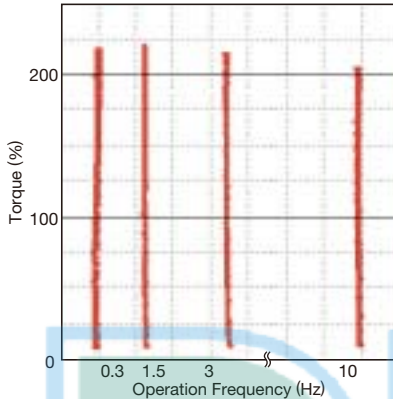

High torque from 1/200 speed
 (Dynamic auto-tuning, open loop vector control)
 [speed control range 1:200 with PG 1:1000]
 Note: To perform continuous high-torque operation at a low speed of 1/10 or less, use an Inverter with a higher capacity than the motor.

Accurate torque control

- The precision torque limit function allows accurate control of the output torque, protecting your machines from sudden load fluctuations.

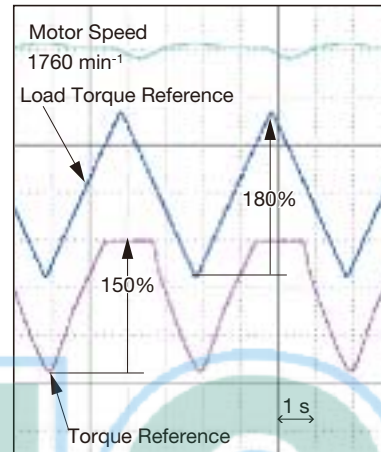

Torque Control (Torque limit set at 150%)

Proven responsiveness

- The model tracking control assures fast response even without PG (doubled in in-house comparison).
- With a PG you can make use of our unique high-speed current vector control, rapidly responses speed reference changes (speed response 40 Hz/motor unit). Speed keeps constant even if load fluctuates.

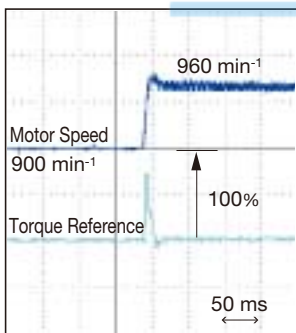

Quick response to reference changes
 (Speed reference step response)

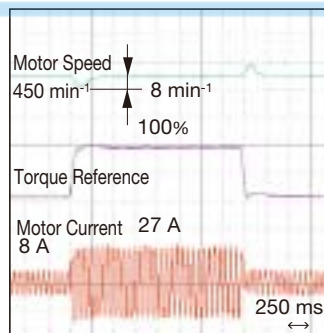

Handles sudden load fluctuations
 (Speed recovery characteristics upon load surges)

High-speed search (patent pending)

- The high-speed search function reduces the recovery time after momentary power loss (halved in in-house comparison).
- Recovery is possible regardless of direction of rotation.



Quick, shockless start
 (Continued operation after momentary power loss)

Simple auto-tuning

- In addition to conventional dynamic auto-tuning, a new static auto-tuning is available to draw out peak performance from the motors of the world.

Safety and protection functions

- High-speed, high-precision current control functions support continuous operation by suppressing overcurrent trips, restart after momentary power loss, stall prevention and fault retry.
- The PTC thermistor in the motor helps protect it against overheating.

User-friendly

Simple operation

- The 5-line LCD display operator makes it simple to check necessary information. And the copy function simplifies constant upload and download.
- Easy to setup with the quick program mode.
- Changed constants can be checked at once by the verify mode.
- With the optional extension cable, remote operation is available.
- An LED display operator is available for option.



Easy maintenance and inspection

- Detachable terminals make it easy to exchange units fully wired.
- The one-touch detachable cooling fan life is extended with the on/off control function.
- The cumulative operation time, cooling fan operation time, and replacement schedule of the electrolytic capacitor and cooling fan can be recorded and displayed with the digital operator. By using the multi-function digital outputs or communication field networks, system management can easily be unified with a host controller.
- A support tool using a PC is also available. All constants of each Inverter can be managed by a PC.
- The output frequency, output current, and I/O terminal status when the error occurred can be monitored to make maintenance easier.



Various I/O interfaces

- In addition to analog command input and analog monitor output, it also supports pulse train command input and pulse train monitor output.
- Offers 12 multi-function inputs and 5 multi-function outputs.
- Input terminal logic can be switched to NPN/PNP type. A +24 V external power supply is also available for selecting the signal input.

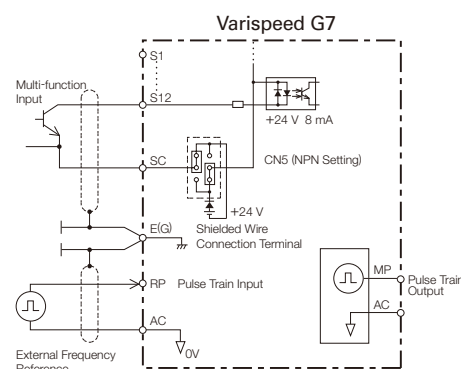

Easy to make exclusive Inverter

- The Varispeed G7 lets you make your exclusive Inverters with custom software equipping the special functions for your specific machines.
- The rich software library, based on our extensive drive expertise*, helps you upgrade your equipment.

* Crane control, elevator control, energy-saving control (max. motor operation efficiency), PID control, etc.

Digital Operator Functions

Mode Display

- DRIVE : LED lights at Drive Mode.
- QUICK : LED lights at Quick Programming Mode.
- ADV : LED lights at Advanced Programming Mode.
- VERIFY : LED lights at Verify Mode.
- A. TUNE : LED lights at Auto-tuning Mode.

Operation Mode Selection Key

The operation mode is alternated with REMOTE (control circuit terminal) and LOCAL (digital operator) (When operational command and frequency reference are set at control circuit terminal.)

Run Command Keys

Run command keys for use by digital operator. Enabled only in the drive mode.

- JOG : Jog run is enabled while depressing this key.
- FWD/REV : Selects forward or reverse run. Forward and reverse run is alternated.
- RUN* : Red LED lights by depressing RUN.
- STOP* : Red LED lights by depressing STOP.

Rotating Direction Display

- FWD : LED lights at forward run.
- REV : LED lights at reverse run.

Remote Mode

- Lights when selecting input mode from the control circuit terminal.
- SEQ : LED lights when selecting run command from control circuit terminal.
- REF : LED lights when selecting frequency reference from control circuit terminals A1 and A2.

Alarm Display

Rdy Display

Can operate when a drive command is input.

Data Display

Displays data for monitoring, user constants, and set values. (1 line×13 characters and 3 lines×16 characters)

Menu Key

Changes the display of operation and programming mode.

Escape Key

Returns to the status entered before [DATA/ENTER] key was pressed.

DATA/ENTER Key

Selects mode, group, function or constant name. Displays each constant set value while displaying a constant name. By pressing this key again, the set value is written in.

▲ : Increment key

▼ : Decrement key

Selects mode, group, function, constant name or set value.

Shift/Reset Key

Selects a digit of a set value to be changed. The selected digit blinks. (Resets operation at faults.)

*** RUN or STOP LED turns ON or OFF, or blinks in accordance with each operation.**

Inverter Output Frequency	[STOP]		[RUN]	[STOP]
Frequency Setting	[RUN LED]	[STOP LED]	[RUN LED]	[STOP LED]
	●	☼	●	☼

☼ : ON ☼ : Blinking ● : OFF

Easy Operation with Digital Operator

Description	Key Operation	Operator Display	Description	Key Operation	Operator Display
① Power ON · Displays frequency reference value.		-DRIVE- Rdy Frequency Ref U1-01 = 0.00Hz ----- U1-02 = 0.00Hz U1-03 = 0.00A REMOTE (SEQ.REF) LED ON (d1-01=0.00Hz)			-DRIVE- Rdy Frequency Ref U1-01 = 15.00Hz ----- U1-02 = 0.00Hz U1-03 = 0.00A
② Operation Condition Setting · Select LOCAL mode.	LOCAL REMOTE	REMOTE (SEQ.REF) LED OFF FWD LED ON -DRIVE- Rdy Frequency Ref U1-01 = 6.00Hz ----- U1-02 = 6.00Hz U1-03 = 1.45A	⑤ Forward Run · Forward Run (15 Hz)	ESC ^	-DRIVE- Rdy Output Freq U1-02 = 0.00Hz ----- U1-03 = 0.00A U1-04 = 2
③ Forward Jog Run (6 Hz) JOG run procedure (RUNs while depressing JOG key.)	JOG	-DRIVE- Rdy Frequency Ref U1-01 = 6.00Hz ----- U1-02 = 6.00Hz U1-03 = 1.45A		o RUN	-DRIVE- Rdy Output Freq U1-02 = 15.00Hz ----- U1-03 = 1.45A U1-04 = 2 * RUN RUN LED ON
④ Frequency Setting · Change reference value.	DATA ENTER	-DRIVE- Rdy Frequency Ref U1-01 = 000.00Hz (0.00 ↔ 60.00Hz) 0.00Hz	⑥ Reverse Run · Switch to reverse run.	FWD REV	-DRIVE- Rdy Output Freq U1-02 = 15.00Hz ----- U1-03 = 1.05A U1-04 = 2 REV LED ON
	RESET <V> <^>	-DRIVE- Rdy Frequency Ref U1-01 = 015.00Hz (0.00 ↔ 60.00Hz) 0.00Hz			
	DATA ENTER	Enter Accepted	⑦ Stop · Decelerates to a stop.	o STOP	-DRIVE- Rdy Output Freq U1-02 = 0.00Hz ----- U1-03 = 0.00A U1-04 = 2 * STOP STOP LED ON (RUN LED blinks during deceleration.)
· Write-in set value.					
(cont'd)					

Note: ■ expresses blinking of numbers

Monitor Display Procedure

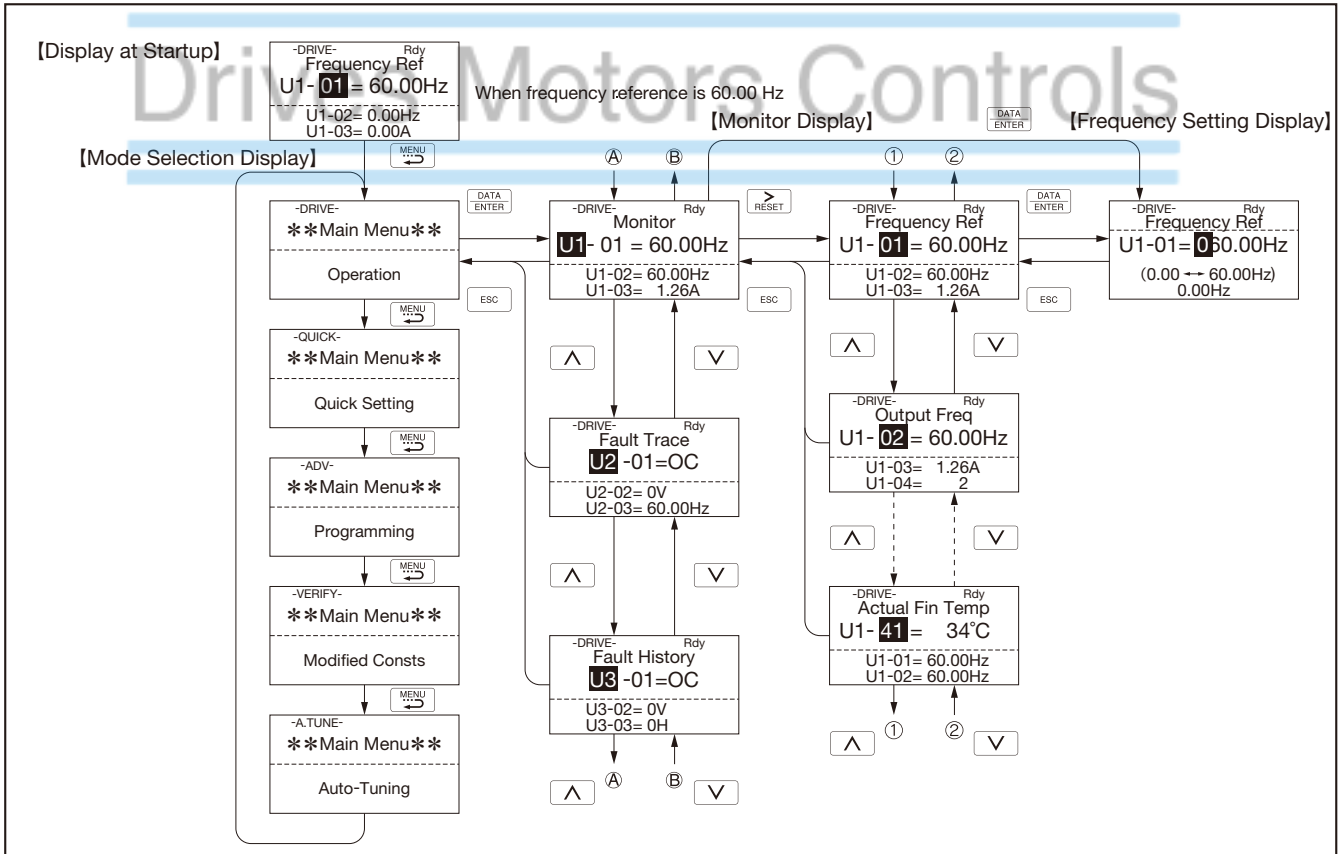

Note: ■ expresses blinking of numbers

Standard Specifications

200 V Class*1

Model	CIMR-G7A	20P4	20P7	21P5	22P2	23P7	25P5	27P5	2011	2015	2018	2022	2030	2037	2045	2055	2075	2090	2110	
Max. Applicable Motor Output*2	kW	0.4	0.75	1.5	2.2	3.7	5.5	7.5	11	15	18.5	22	30	37	45	55	75	90	110	
Rated Input Current*3	A	3.8	7.2	9.6	14.4	22	32	40	59	79	88	106	143	176	201	246	330	394	457	
Output Ratings	Rated Output Capacity	kVA	1.2	2.3	3.0	4.6	6.9	10	13	19	25	30	37	50	61	70	85	110	140	160
	Rated Output Current	A	3.2	6	8	12	18	27	34	49	66	80	96	130	160	183	224	300	358	415
	Max. Output Voltage	3-phase, 200/208/220/230/240 V (Proportional to input voltage)																		
Max. Output Frequency	400 Hz by constant setting*4																			
Power supply	Rated Input Voltage and Frequency	Three-phase AC power supply: 200/208/220/230/240 V, 50/60 Hz*5 DC power supply: 270 to 340 V*6																		
	Allowable Voltage Fluctuation	+10%, -15%																		
	Allowable Frequency Fluctuation	±5%																		
Measures for power supply harmonics	DC Reactor	Option									Provided									
	12-Pulse Input	Not available									Available*7									
Environmental Conditions	Vibration	9.8 m/s ² at 10 Hz to 20 Hz or below, up to 5.9 m/s ² at 20 Hz to 55 Hz													9.8 m/s ² at 10 Hz to 20 Hz or below, up to 2.0 m/s ² at 20 Hz to 55 Hz					

*1: The main circuit of 200 V class Inverters uses 2-level control method.

*2: The maximum applicable motor output is given for a standard Yaskawa 4-pole motor. Choose an Inverter with a rated output current that is greater than or equal to the rated current of the motor. However, do not select a motor with a larger capacity than the capacity given for the maximum applicable motor. Also, to perform continuous high-torque operation at a low speed of 1/10 or less, use an Inverter with a higher capacity (kW) than the motor.

*3: The rated input current depends on the impedance at the power supply (including the power transformer, input reactor, and wires).

*4: The setting range for open-loop vector control 2 is 0 to 66 Hz (for PROG: 103□, 0 to 132 Hz).

*5: When using the inverter of 200 V 30 kW or more with a cooling fan of 3-phase 230 V 50 Hz or 240 V 50/60 Hz power supply, a transformer for the cooling fan is required.

*6: Not compliant with UL or CE standards when using a DC power supply.

*7: Customer must provide a 3-winding transformer when using 12-pulse input.

400 V Class*1

Model	CIMR-G7A	40P4	40P7	41P5	42P2	43P7	45P5	47P5	4011	4015	4018	4022	4030	4037	4045	4055	4075	4090	4110	4132	4160	4185	4220	4300	
Max. Applicable Motor Output*2	kW	0.4	0.75	1.5	2.2	3.7	5.5	7.5	11	15	18.5	22	30	37	45	55	75	90	110	132	160	185	220	300	
Rated Input Current*3	A	2.2	4.1	5.8	7.4	10.8	18	25	32	40	46	57	72	88	107	141	182	215	264	297	332	407	495	666	
Output Ratings	Rated Output Capacity	kVA	1.4	2.6	3.7	4.7	6.9	11	16	21	26	32	40	50	61	74	98	130	150	180	210	230	280	340	460
	Rated Output Current	A	1.8	3.4	4.8	6.2	9	15	21	27	34	42	52	65	80	97	128	165	195	240	270	302	370	450	605
	Max. Output Voltage	3-phase, 380/400/415/440/460/480 V (Proportional to input voltage)																							
Max. Output Frequency	400 Hz by constant setting*4,*5																								
Power supply	Rated Input Voltage and Frequency	Three-phase AC power supply: 380/400/415/440/460/480 V, 50/60 Hz DC power supply: 510 to 680 V*6																							
	Allowable Voltage Fluctuation	+10%, -15%																							
	Allowable Frequency Fluctuation	±5%																							
Measures for power supply harmonics	DC Reactor	Option											Provided												
	12-Pulse Input	Not available											Available*7												
Environmental Conditions	Vibration	9.8 m/s ² at 10 Hz to 20 Hz or below, up to 5.9 m/s ² at 20 Hz to 55 Hz													9.8 m/s ² at 10 Hz to 20 Hz or below, up to 2.0 m/s ² at 20 Hz to 55 Hz										

*1: The main circuit of 400 V class Inverters uses 3-level control method.

*2: The maximum applicable motor output is given for a standard Yaskawa 4-pole motor. Choose an Inverter with a rated output current that is greater than or equal to the rated current of the motor. However, do not select a motor with a larger capacity than the capacity given for the maximum applicable motor. Also, to perform continuous high-torque operation at a low speed of 1/10 or less, use an Inverter with a higher capacity (kW) than the motor.

*3: The rated input current depends on the impedance at the power supply (including the power transformer, input reactor, and wires).

*4: The setting range for open-loop vector control 2 is 0 to 66 Hz (for PROG: 103□, 0 to 132 Hz).

*5: For the 400 V class, there are limitations on the maximum output frequency depending on the setting of the carrier frequency and capacity. The maximum output frequency is 250 Hz for 90 kW to 110 kW and 166 Hz for 132 kW to 300 kW Inverters. Contact your Yaskawa representative for details.

*6: Not compliant with UL or CE standards when using a DC power supply.

*7: Customer must provide a 3-winding transformer when using 12-pulse input.

Protective Structure

Class	Model	CIMR-G7A	20P4	20P7	21P5	22P2	23P7	25P5	27P5	2011	2015	2018	2022	2030	2037	2045	2055	2075	2090	2110
200 V Class	Enclosed wall-mounted type (UL Type 1)	Available as standard											Available for option						Not available	
	Open chassis type (IP00)	Available by removing the upper and lower cover of enclosed wall-mounted type											Available as standard							
400 V Class	Enclosed wall-mounted type (UL Type 1)	Available as standard											Available for option						Not available	
	Open chassis type (IP00)	Available by removing the upper and lower cover of enclosed wall-mounted type											Available as standard							

Enclosed Wall-mounted Type (UL Type 1): The Inverter is structured so that the Inverter is shielded from the exterior, and can thus be mounted to the interior wall of a standard building (not necessarily enclosed in a control panel).

Open Chassis Type (IP00): Protected so that parts of the human body cannot reach electrically charged parts from the front when the Inverter is mounted in a control panel.

Model Designation

CIMR - G7 A 2 0P4 0

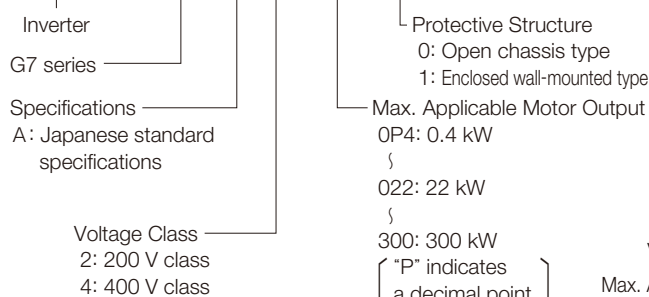

Name Plate Example

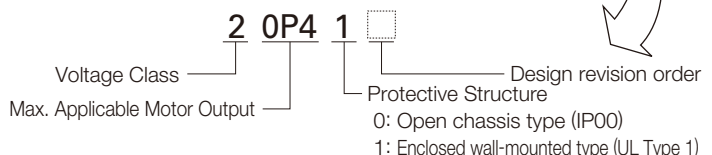

200/400 V Class

Control characteristics	Control method	Sine wave PWM [Vector with PG, open loop vector 1, open loop vector 2*1, V/f, and V/f with PG (switched by constant setting)]
	Starting Torque	150% at 0.3 Hz (open loop vector control 2), 150% at 0 min ⁻¹ (vector control with PG)*2
	Speed Control Range	1:200 (open loop vector control 2), 1:1000 (vector control with PG)*2
	Speed Control Accuracy	±0.2%*3 (open loop vector control 2 at 25°C±10°C), ±0.02% (vector control with PG at 25°C±10°C)*2
	Speed Response	10 Hz (open loop vector control 2), 40 Hz (vector control with PG)*2
	Torque Limit	Can be set by parameter: 4 steps available (only when vector control)
	Torque Accuracy	±5%
	Frequency Control Range	0.01 Hz to 400 Hz*4, *5
	Frequency accuracy (temperature characteristics)	Digital reference: ±0.01%, -10°C to +40°C ; Analog reference: ±0.1%, 25°C ±10°C
	Frequency Setting Resolution	Digital reference: 0.01 Hz; Analog reference: 0.03 Hz/60 Hz (11-bit + sign)
	Output Frequency Resolution	0.001 Hz
	Overload Capacity*7	150% rated output current for 1 minute, 200% rated output current for 0.5 s
	Frequency Setting Signal	-10 to 10 V, 0 to 10 V, 4 to 20 mA, pulse train
	Accel/Decel Time	0.01 to 6000.0 s (4 selectable combinations of independent acceleration and deceleration settings)
Main Control Functions	Braking Torque	Approx. 20% (Approx. 125% when using braking resistor)*6 Built-in braking transistor provided for Inverters of 15 kW or less (200/400 V)
		Momentary power loss restart, Speed search, Overtorque detection, Torque limit, 17-step speed operation (maximum), Accel/dec el time changeover, S-curve accel/dec el, 3-wire sequence, Auto-tuning (rotational or stationary), DWELL, Cooling fan ON/OFF, Slip compensation, Torque compensation, Jump frequency, Frequency upper/lower limit settings, DC injection braking at start/stop, High slip braking, PID control (with sleep function), Energy-saving control, MEMOBUS communications (RS-485/422 max. 19.2 kbps), Fault retry, Constant copy, Droop control, Torque control, Speed/torque control changeover, feed forward control, Zero-servo control, etc.
Protective Functions	Motor Overload Protection	Protection by electronic thermal overload relay.
	Instantaneous Overcurrent	Stops at approx. 200% of rated output current.
	Fuse blown protection	Motor coasts to stop at blown fuse.
	Overload	150% rated output current for 1 minute, 200% rated output current for 0.5 s
	Overvoltage	200 Class Inverter: Stops when main-circuit DC voltage is approximately above 410 V. 400 Class Inverter: Stops when main-circuit DC voltage is approximately above 820 V.
	Undervoltage	200 Class Inverter: Stops when main-circuit DC voltage is approximately below 190 V. 400 Class Inverter: Stops when main-circuit DC voltage is approximately below 380 V.
	Momentary Power Loss Ridethrough	Stops for 15 ms or more (at factory setting). With a suitable constant setting, operation can be continued if power is restored within 2 s.*8
	Cooling Fin Overheating	Protection by thermistor.
	Stall Prevention	Stall prevention during acceleration/deceleration and constant speed operation
Environmental Conditions	Grounding Protection*9	Provided by electronic circuit (overcurrent level)
	Power Charge Indication	Lit when the main circuit DC voltage is approx. 50 V or more.
	Location	Indoor (Protected from corrosive gasses and dust)
	Humidity	95%RH (non-condensing)
	Storage Temperature	-20 to 60°C (short-term temperature during transportation)
	Ambient Temperature	-10°C to 40°C (Enclosed wall-mounted type) -10°C to 45°C (Open chassis type)
	Altitude	1000 m max.

*1: Do not use open-loop vector control 2 for elevator applications. Any other control method can be used.

*2: Specifications for open loop vector control 1 or 2 and vector control with PG require dynamic auto-tuning.

*3: The speed control accuracy depends on the installation conditions and type of motor used. Contact your Yaskawa representative for details.

*4: The setting range for open-loop vector control 2 is 0.01 to 132 Hz.

*5: For the 400 V class, there are limitations on the maximum output frequency depending on the setting of the carrier frequency and capacity. The maximum output frequency is 250 Hz for 90 kW to 110 kW and 166 Hz for 132 kW to 300 kW Inverters in the 400 V class. Contact your Yaskawa representative for details.

*6: When using a braking resistor or braking resistor unit, set L3-04=0 (deceleration stall prevention). If not, motor may not stop at the set time.

*7: Applications with repetitive loads (cranes, elevators, presses, washing machines, etc.) using Inverters require derating for the repetitive load [reducing carrier frequency and current (increasing the frame size of the Inverter)]. For details, refer to Precautions for Repetitive Load Applications on page 101. If running at a speed of 6 Hz or less, the overload protection function can operate even if running within 150% of rated output current per minute.

*8: Drives with a capacity of smaller than 7.5 kW in the 200 V or 400 V require a separate Momentary Power Loss Recovery Unit (optional).

*9: Protection is provided when the motor is grounded during Run. Protection may not be provided under the following conditions:

- Low resistance to ground from the motor cable or terminal block.
- Inverters already has a short-circuit when the power is turned on.

Software Functions

The Varispeed G7 flexible Inverter incorporates a variety of application features. Select special functions from a multitude of possibilities to perfectly match your machine requirements.

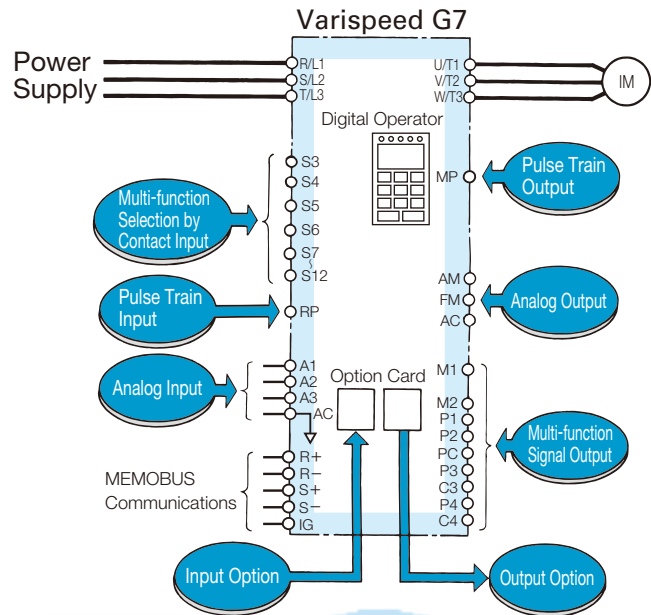

Function	Target Market	Application	Description of Function	Ref. Page
Energy Saving Control	General	Most efficient automatic operation	Supplies voltage to motor to always be most effective according to load and rotating speed. (Automatic temperature compensation function provided)	55
PID Control	Pumps, air conditionings, etc.	Automatic process control	Processes PID operation in the Inverter and the result is used as frequency reference. It controls pressure, air/water amounts.	53
Speed Search Operation	Inertia load drives such as blowers, etc.	Synchronize with the coasting motor	Starts the Inverter at the specified frequency, automatically detects the synchronization point, and performs at the operation frequency. No speed detector is required.	40
DC Injection Braking at Start	Blowers, pumps, etc. which have wind-mill effects	Starting the free running motor	When the direction of the free running motor is not fixed, the speed search operation function is difficult to use. The motor can be automatically stopped by DC injection braking, and be restarted by the Inverter.	40
Commercial Power Source/Inverter Switchover Operation	Blowers, pumps, mixers, extruders, etc.	Automatic switching between commercial power source and Inverter	Switching of commercial power source to Inverter or vice versa is done without stopping the motor.	40, 58
Multi-step Speed Operation	Transporting equipment	Schedule operation under fixed speed and positioning	Multi-step operation (up to 17-step) can be set by setting the contact combinations, so the connection with PLC becomes very easy. When combined with jog speed can also allow simple positioning.	36
Accel/Decel Time Changeover Operation	Automatic control panels, transporting equipment, etc.	The accel/decel time changeover with an external signal	The acceleration/deceleration rate is switched by an external contact signal. This operation is effective if you use one Inverter to operate two motors, need smoother acceleration/deceleration only in a high-speed range, etc.	37
Inverter Overheat Prediction	Air conditioners, etc.	Preventive maintenance	When the ambient temperature of the Inverter rises to within 10°C of the maximum allowable temperature, warning is given. (Thermoswitch is required as an option.)	47
3-wire Sequence	General	Simple configuration of control circuit	Operation can be accomplished using a spring-loaded push-button switch.	47
Operating Site Selection	General	Easy operation	Operation and settings can be selected while the Inverter is online. (digital operator/external instruction, signal input/output).	47
Frequency Hold Operation	General	Easy operation	Temporarily holds frequencies during acceleration or deceleration.	41
UP/DOWN Command	General	Easy operation	Sets speed by ON/OFF from a distance.	47
Fault Trip Retry Operation	Air conditioners, etc.	Improvement of operation reliability	When the Inverter trips, it begins to coast, is immediately diagnosed by computer, resets automatically, and returns to the original operation speed. Up to 10 retries can be selected.	41
Quick Stop without Braking Resistor (DC injection braking stop)	High-speed routers, etc.	DC injection braking stop of induction motor	DC injection braking is performed at top speed. The duty is 5% or less. Can generate 50% to 70% of the braking torque.	46
Torque Limit (drooping characteristic selection)	Blowers, pumps, extruders, etc.	<ul style="list-style-type: none"> Protection of machine Improvement of continuous operation reliability Torque limit 	The Inverter can be switched to coasting or motor speed reducing mode as soon as it reaches a certain preset torque level. For pump or blower, the operation frequency can be automatically reduced to the load balancing point, according to the overload condition, and prevent overload tripping.	49

Function	Target Market	Application	Description of Function	Ref. Page
Torque Control*	Winders, extruders, boosters	· Tension constant control · Torque booster	Adjusts motor torque externally. Appropriate for controlling winder tension and the result of torque booster.	—
Droop Control*	Separately-driven conveyors, multimotor drive, feeders, transporting equipment.	Dividing loads	Arbitrarily set motor speed regulation. High insulation characteristics share multi-motor loads.	—
Upper/Lower Frequency Limit Operation	Pumps, blowers	Motor speed limit	The upper and lower limits of the motor speed, reference signal bias and gain can be set independently without peripheral operation units.	38
Prohibit Setting of Specific Frequency (Frequency Jump Control)	General machines	Prevent mechanical vibration in the equipment	To avoid resonance characteristics of the machine system, the frequency that causes resonance can be jumped during constant-speed operation. This function can also be applied to dead band control.	38
Carrier Frequency Setting	General machines	Lower noise, eliminate resonance	The carrier frequency can be set to reduce the acoustic noise from the motor and machine system.	44
Automatic Continuous Operation When the Speed Reference is Lost	Air conditioners	Improving reliability of continuous operation	When the frequency reference signal is lost, operation is automatically continued at the pre-programmed speed. (If the host computer fails.) This function is important for air conditioning systems in intelligent buildings.	40
Load Speed Display	General	Monitor function enhancement	Can indicate motor speed (min^{-1}), machine speed under load (min^{-1}), line speed (m/min), etc.	35
Run Signal	General	Zero-frequency interlock	"Closed" during operation. "Open" during coasting to a stop. Can be used as interlock contact point during stop.	48
Zero-speed Signal	Machine tools	Zero-frequency interlock	"Closed" when output frequency is under min. frequency. Can be used as tool exchange signal.	48
Frequency (Speed) Agreed Signal	Machine tools	Reference speed reach interlock	The contact closes when Inverter output frequency reaches the set value. Can be used as an interlock for lathes, etc.	48
Overtorque Signal	Machine tools, blowers, cutters, extruders, etc.	· Protection of machine · Improvement of operation reliability	"Closed" when overtorque setting operation is accomplished. Can be used as an interlock signal to protect a machine, such as for detection of blade damage or overloads in machine tools.	42
Low Voltage Signal	General	System protection for undervoltage	"Closed" only when tripped by low voltage. Can be used as a countermeasure power loss detection relay.	48
Free Unintentional Speed Agreement Signal	General	Reference speed agreed interlock	"Closed" when the speed agrees at arbitrary frequency reference.	48
Output Frequency Detection 1	General	Gear change interlock etc.	"Closed" at or over an arbitrary output frequency.	48
Output Frequency Detection 2	General	Gear change interlock etc.	"Closed" at or below the arbitrary output frequency.	48
Base Block Signal	General	Operation interlock, etc.	Always "closed" when the Inverter output is OFF.	48
Braking Resistor Protection	General	Preventive maintenance	"Closed" when a built-in braking resistor overheats, or a braking transistor error is detected.	48
Frequency Reference Sudden Change Detection	General	Operation stability	"Closed" when the frequency reference suddenly drops to 10% or below of the set value. Can also be used for host sequencer error detection.	48
Multi-function Analog Input Signal	General	Easy operation	Functions as supplementary frequency reference. Also used for fine control of input reference, output voltage adjustment, external control of accel/dec time, and fine adjustment of overtorque detection level.	—
Multi-function Analog Output Signal	General	Monitor function enhancement	Any two of the following can be used: frequency meter, ammeter, voltmeter, wattmeter, or U1 monitor.	44
Analog Input (option)	General	Easy operation	Enables external operation with high resolution instructions (AI-14U, AI-14B). Also enables normal and reverse operation using positive or negative voltage signals (AI-14B).	—
Digital Input (option)	General	Easy operation	Enables operation with 8-bit or 16-bit digital signals. Easily connects to NC or PC (DI-08, DI-16H2).	—
Analog Output (option)	General	Monitor function enhancement	Monitors output frequency, motor current, output voltage, and DC voltage. (AO-08, AO-12)	44
Digital Output (option)	General	Monitor function enhancement	Indicates errors through discrete output (DO-08).	—
Pulse Train Input	General	Easy operation	PID target and PID feedback values are input with pulse train when PID control as well as frequency reference function.	38
Pulse Train Output	General	Monitor function enhancement	Six items including PID target and PID feedback values can be monitored as well as frequency reference and output frequency.	45
PG Speed Control (option)	General	Enhancement of speed control	Installing PG controller card (PG-A2, PG-B2, PG-D2, PG-X2) considerably enhances speed control accuracy.	51

* Torque control and droop control functions are applicable for vector control with PG and open loop vector control 2.

Connection Diagram and Terminal Functions

Varispeed G7

Example of 200 V 18.5 kW (CIMR-G7A2018)

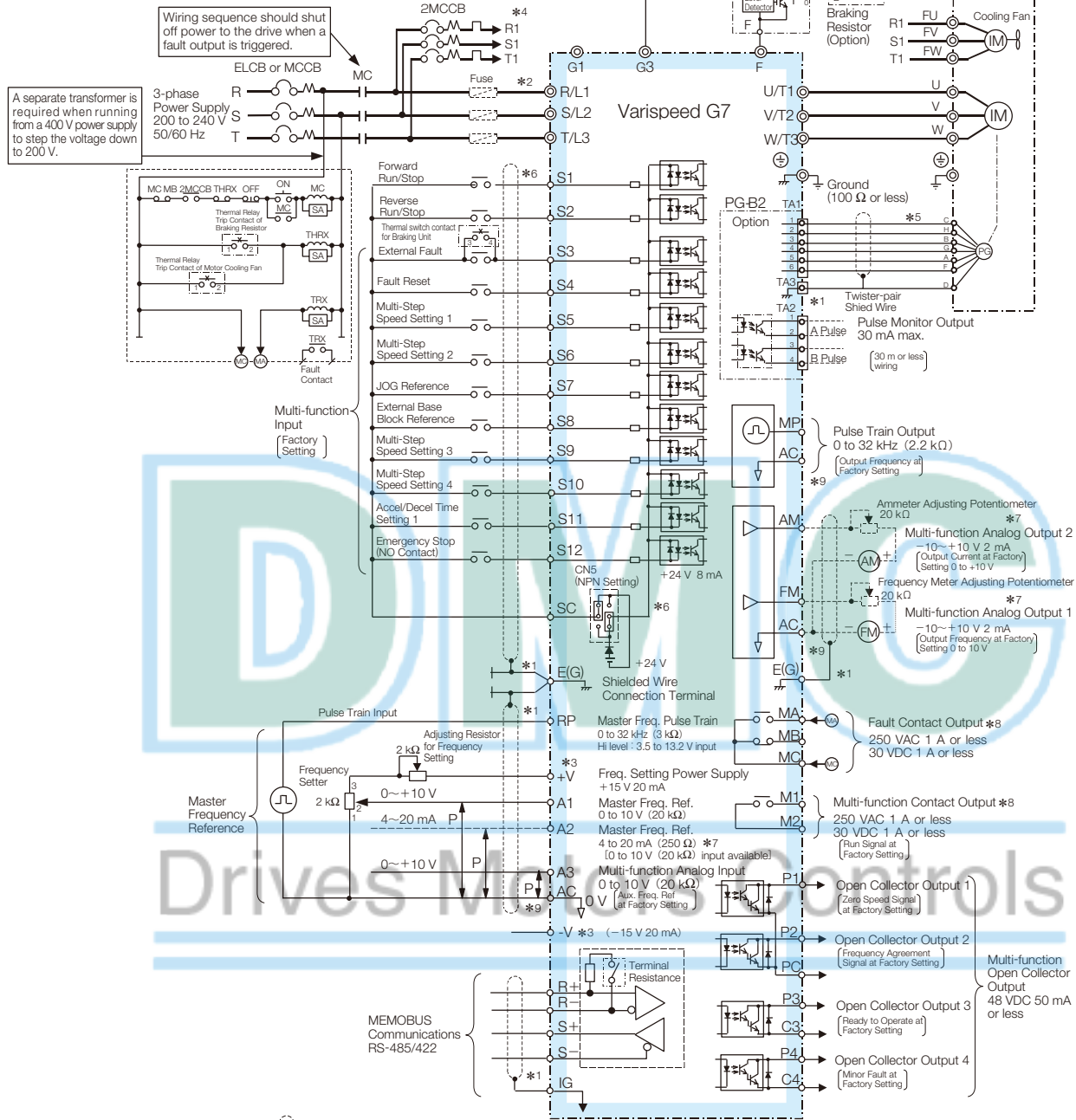

*1: indicates shield wire and P indicates twisted-pair shield wire.

*2: Terminal symbols: shows main circuit; shows control circuit.

*3: The output current capacity of the +V and -V terminals are 20 mA. Do not short-circuit between the +V, -V, and AC terminals. Doing so may result in a malfunction or a breakdown of the Inverter.

*4: When using self-cooled motors, wiring for cooling fan motor is not required.

*5: PG circuit wiring (i.e., wiring to the PG-B2 Board) is not required for control without a PG.

*6: Connection when sequence input signals (S1 to S12) are no-voltage contacts or sequence connections (0 V common/sink mode) by NPN transistor (factory setting). When sequence connections by PNP transistor (+24 V common/source mode) or preparing an external +24 V power supply, see Typical Connection Diagrams (p64).

*7: Multi-function analog output is only for use on meters (frequency, current, voltage and watt), and not available for the feedback control system.

*8: The minimum permissible load of a multi-function contact output and an error contact output is 10 mA. Use a multi-function open-collector output for a load less than 10 mA.

*9: Do not ground nor connect the AC terminal on the control circuit to the unit. Doing so may result in a malfunction or a breakdown of the Inverter.

*10: Set constant L8-01 to 1 when using a braking resistor (model ERF). When using a Braking Resistor Unit, a shutoff sequence for the power supply must be made using a thermal relay trip.

Note: For applications where the power supply for the Inverter's main circuit is turned off while the power supply for the Inverter's control circuit is on, a power-supply unit for each circuit and a specially designed Inverter are available. Contact your Yaskawa representative for more information.

Control Circuit and Communication Circuit Terminal Arrangement

Screw type terminal

E(G)	FM	AC	AM	P1	P2	PC	SC
	SC	A1	A2	A3	+V	AC	-V
S1	S2	S3	S4	S5	S6	S7	S8

Screw terminal

MP	P3	C3	P4	C4
RP	R+	R-	S+	S-
S9	S10	S11	S12	IG

Screw type terminal

MA	MB	MC
M1		M2
		E(G)

Terminal Functions

Main Circuit

Voltage		200 V			400 V		
Model CIMR-G7A	20P4 to 2015	2018, 2022	2030 to 2110	40P4 to 4015	4018 to 4045	4055 to 4300	
Max. Applicable Motor Output	0.4 to 15 kW	18.5 to 22 kW	30 to 110 kW	0.4 to 15 kW	18.5 to 45 kW	55 to 300 kW	
R/L1, S/L2, T/L3	Main circuit input power supply	Main circuit input power supply R-R1, S-S1 and T-T1 have been wired before shipment (See P66).		Main circuit input power supply	Main circuit input power supply R-R1, S-S1 and T-T1 have been wired before shipment (See P66).		
R1/L11, S1/L21, T1/L31	—	—		—	—		
U/T1, V/T2, W/T3	Inverter output			Inverter output			
B1, B2	Braking resistor unit	—		Braking resistor unit	—		
⊖	—	—		—	—		
⊕1	·DC reactor (⊕1 — ⊕2)	·DC power supply (⊕1 — ⊖)*1		·DC reactor (⊕1 — ⊕2)	·DC power supply (⊕1 — ⊖)*1		
⊕2	·DC power supply*1 (⊕1 — ⊖)	·Braking unit (⊕3 — ⊖)		·DC power supply*1 (⊕1 — ⊖)	·Braking unit (⊕3 — ⊖)		
⊕3	—	—		—	—		
Δ/Δ2	—	Cooling fan power supply*2		—	—		
r/Δ1	—	—		—	Cooling fan power supply*3		
Δ 200/Δ2200	—	—		—	—		
Δ 400/Δ2400	—	—		—	—		
⊕	Ground terminal (100 Ω or less)			Ground terminal (10 Ω or less)			

*1: ⊕1 — ⊖ DC power input does not conform to UL/c-UL listed standard.

*2: Cooling fan power supply r/Δ1 — Δ/Δ2: 200 to 220 VAC 50 Hz, 200 to 230 VAC 60 Hz (A transformer is required for 230 V 50 Hz or 240 V 50/60 Hz power supply.)

*3: Cooling fan power supply r/Δ1 — Δ 200/Δ2 200: 200 to 220 VAC 50 Hz, 200 to 230 VAC 60 Hz, r/Δ1 — Δ 400/Δ2 400: 380 to 480 VAC 50/60 Hz

Control Circuit (200 V/400 V Class)

Classification	Terminal	Signal Name	Description	Signal Level
Sequence Input	S1	Forward run-stop signal	Forward run at "closed", stop at "open"	Photo-coupler insulation Input 24 VDC 8 mA
	S2	Reverse run-stop signal	Reverse run at "closed", stop at "open"	
	S3	Multi-function input selection 1	Factory setting: external fault at "closed"	
	S4	Multi-function input selection 2	Factory setting: fault reset at "closed"	
	S5	Multi-function input selection 3	Factory setting: multi-step speed setting 1 is valid at "closed"	
	S6	Multi-function input selection 4	Factory setting: multi-step speed setting 2 is valid at "closed"	
	S7	Multi-function input selection 5	Factory setting: JOG run at "closed"	
	S8	Multi-function input selection 6	Factory setting: external baseblock at "closed"	
	S9	Multi-function input selection 7	Factory setting: multi-speed setting 3 is valid at "closed"	
	S10	Multi-function input selection 8	Factory setting: multi-speed setting 4 is valid at "closed"	
	S11	Multi-function input selection 9	Factory setting: accel/decel time setting 1 is valid at "closed"	
	S12	Multi-function input selection 10	Factory setting: emergency stop (NO contact) is valid at "closed"	
	SC	Sequence control input common	—	
Analog Input	+V	+15 V Power supply output	For analog reference +15 V power supply	+15 V (Allowable current 20 mA max.)
	-V	-15 V Power supply output	For analog reference -15 V power supply	-15 V (Allowable current 20 mA max.)
	A1	Master speed frequency ref.	-10 to +10 V / -100 to +100%, 0 to +10 V/100%	-10 to +10 V, 0 to +10 V (Input impedance 20 k)
	A2	Multi-function analog input	4 to 20 mA/100%, -10 to +10 V / -100 to +100%, 0 to +10 V/100% Factory setting: added to the terminal A1 (H3-09=0)	4 to 20 mA (Input impedance 250 Ω)
	A3	Master speed frequency ref.	-10 to +10 V / -100 to +100%, 0 to +10 V/100% Factory setting: preset frequency reference	0 to +10 V (Input impedance 20 kΩ)
	AC	Analog common	0 V	—
E (G)	Connection to shield wire and option ground wire	—	—	
Photo-coupler Output	P1	Multi-function PHC output 1	Factory setting: zero speed signal "Closed" at or below zero speed level (b2-01)	48 Vdc or less, 2 to 50 mA Photocoupler output*
	P2	Multi-function PHC output 2	Factory setting: frequency agreement "Closed" within ±2 Hz of setting frequency	
	PC	Photo-coupler output common	—	
	P3	Multi-function PHC output 3	Factory setting: ready to operate (READY)	
	C3	—	—	
	P4	Multi-function PHC output 4	Factory setting: minor fault	
Relay Output	MA	Fault output (NO contact)	Fault at "closed" between terminals MA and MC	Dry contact, contact capacity 250 VAC 1 A or less 30 VDC 1 A or less
	MB	Fault output (NC contact)	Fault at "open" between terminals MB and MC	
	MC	Relay contact output common	—	
	M1	Multi-function contact output (NO contact)	Factory setting: Run signal Running at "closed" between terminals M1 and M2	
Analog Monitor Output	FM	Multi-function analog monitor 1	Factory setting: output frequency 0 to 10 V/100% freq.	0 to ±10 VDC ±5% 2 mA or less
	AM	Multi-function analog monitor 2	Factory setting: current monitor 5 V/Inverter rated current	
	AC	Analog common	—	
Pulse I/O	RP	Multi-function pulse input	Factory setting: frequency reference input (H6-01=0)	0 to 32 kHz (3 kΩ)
	MP	Multi-function pulse monitor	Factory setting: output frequency (H6-06=2)	0 to 32 kHz (2.2 kΩ)

* Connect a flywheel diode as shown below when driving a reactive load such as a relay coil. Diode must be rated higher than the circuit voltage.

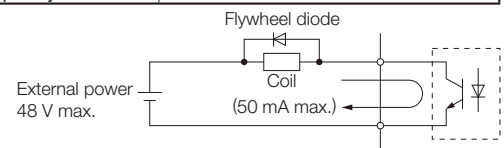

Communication Circuit Terminal (200/400 V Class)

Classification	Terminal	Signal Name	Description	Signal Level
RS-485/422 Transmission	R+	MEMOBUS communication input	When using two RS-485 wires, short-circuit between R+ and S+, R- and S-.	Differential input PHC isolation
	R-			
	S+	MEMOBUS communication output		Differential input PHC isolation
	S-			
	IG	Shielded wire for communication		—

Dimensions

Open Chassis Type (IP00)

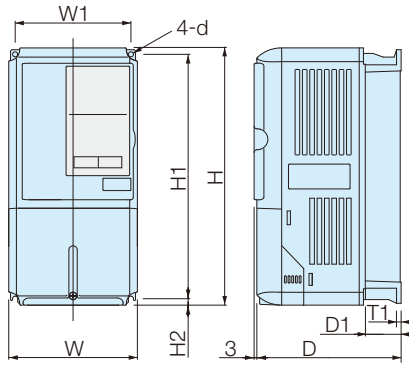

Drawing 1

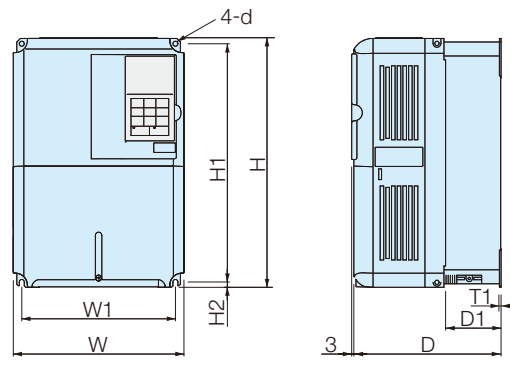

Drawing 2

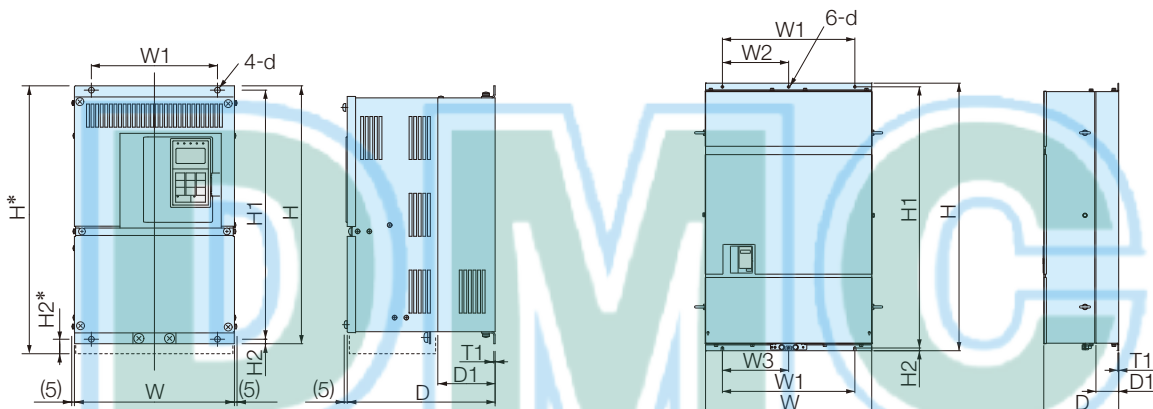

Drawing 3

Drawing 4

Voltage	Max. Applicable Motor Output kW	Inverter CIMR-G7A	DWG	Dimensions in mm											Approx. Mass kg	Cooling Method				
				W	H	D	W1	W2	W3	H1	H2	D1	T1	d						
200 V Class (3-phase)	0.4	20P4	1	140	280	157	126				266	7	39	5	M5	3	Self cooled			
	0.75	20P7				177							59							
	1.5	21P5				177							59							
	2.2	22P2	2	200	300	197	186				285	8	65.5				4	Fan cooled		
	3.7	23P7																	6	
	5.5	25P5																	7	
	7.5	27P5	3	240	350	207	216				335	7.5	78	2.3	M6	11				
	11	2011																	21	
	15	2015																	24	
	18.5	2018	3	275	450	258	195				385	7.5	100				57			
	22	2022																		63
	30	2030																		86
	37	2037	3	375	600	298	250				575	12.5	130				87			
	45	2045																		108
	55	2055																		150
75	2075	3	500	850	358	370				820	15	140	4.5	M12						
90	2090																			
110	2110																			
400 V Class (3-phase)	0.4	40P4	1	140	280	157	126				266	7	39	5	M5	3.5	Self cooled			
	0.75	40P7				177							59							
	1.5	41P5				177							59							
	2.2	42P2	2	200	300	197	186				285	8	65.5				7	Fan cooled		
	3.7	43P7																	7	
	5.5	45P5																	10	
	7.5	47P5	3	240	350	207	216				335	7.5	78	2.3	M6	26				
	11	4011																	37	
	15	4015																		
	18.5	4018	3	275	450	258	220				435	7.5	100				90			
	22	4022																		91
	30	4030																		127
	37	4037	3	325	550	283	260				535	105	105				165			
	45	4045																		175
	55	4055																		263
	75	4075	3	450	725	348	325				700	12.5	130	3.2	M10		91			
	90	4090																		109
	110	4110																		127
132	4132*	4	575	916*	378	445				855	45.8*	140	4.5	M12		165				
160	4160*																		175	
185	4185																		263	
220	4220	4	710	1305	415	540	240	270	1270	15	126	4.5			280					
300	4300																	415		

* Dotted lines show dimensions for models of the CIMR-G7A 4132 and 4160.

Enclosed Wall-Mounted Type (UL Type 1)

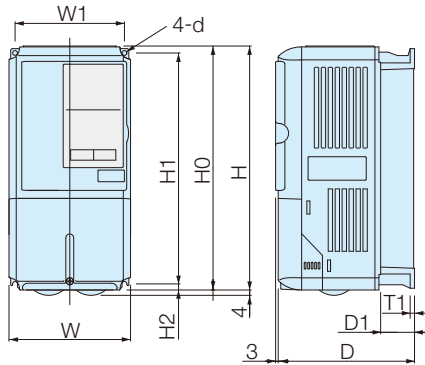

Drawing 1

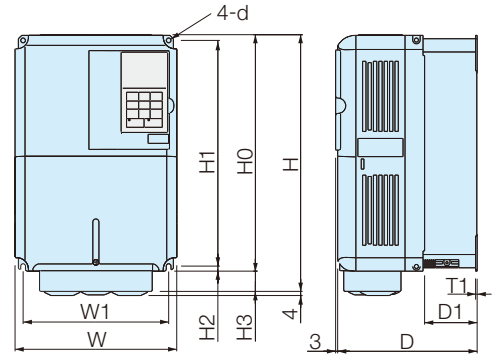

Drawing 2

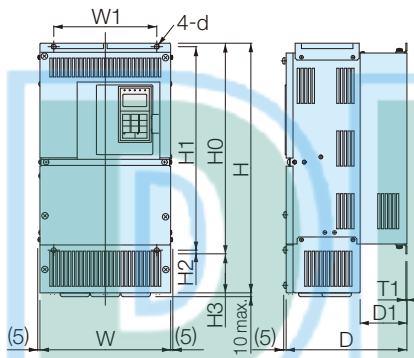

Drawing 3

Voltage	Max. Applicable Motor Output kW	Inverter CIMR-G7A:.....	DWG	Dimensions in mm											Approx. Mass kg	Cooling Method					
				W	H	D	W1	H0	H1	H2	H3	D1	T1	d							
200 V Class (3-phase)	0.4	20P4	1	140	280	157	126	280	266	7	—	39	5	M5	3	Self cooled					
	0.75	20P7				177									59		4				
	1.5	21P5				197									—		6				
	2.2	22P2	2	200	300	197	186	300	285	8	0	65.5	—	—	7	Fan cooled					
	3.7	23P7													7		0	6			
	5.5	25P5													7.5		30	7			
	7.5	27P5	3	240	350	207	216	350	335	7.5	135	78	2.3	M6	11	Fan cooled					
	11	2011													100		24				
	15	2015													165		27				
	18.5	2018	3	254	535	258	195	400	385	7.5	209	100	3.2	M10	62	Fan cooled					
	22	2022													328		68				
	30	2030													250		600	575	12.5	302	130
	37	2037	3	380	809	298	250	600	575	12.5	302	130	3.2	M10	95	Fan cooled					
	45	2045													328		94				
	55	2055													250		600	575	12.5	302	130
75	2075	3	453	1027	348	325	725	700	15	393	130	4.5	M12	114	Fan cooled						
55	2055													370		850	820	15	393	130	114
75	2075													370		850	820	15	393	130	114
400 V Class (3-phase)	0.4	40P4	1	140	280	157	126	280	266	7	—	39	5	M5	3.5	Self cooled					
	0.75	40P7				177									59		4.5				
	1.5	41P5				197									—		6				
	2.2	42P2	2	200	300	197	186	300	285	8	—	65.5	—	—	7	Fan cooled					
	3.7	43P7													7		0	6			
	5.5	45P5													7.5		30	7			
	7.5	47P5	3	240	350	207	216	350	335	7.5	85	100	2.3	M6	10	Fan cooled					
	11	4011													100		24				
	15	4015													165		27				
	18.5	4018	3	279	535	258	220	450	435	7.5	165	105	3.2	M10	29	Fan cooled					
	22	4022													328		68				
	30	4030													250		600	575	12.5	302	130
	37	4037	3	329	635	283	260	550	535	7.5	165	105	3.2	M10	98	Fan cooled					
	45	4045													328		94				
	55	4055													250		600	575	12.5	302	130
	75	4075	3	453	1027	348	325	725	700	15	393	130	4.5	M12	99	Fan cooled					
	90	4090													370		850	820	15	393	130
110	4110	370													850		820	15	393	130	127
132	4132	3	504	1243	358	370	850	820	15	393	130	4.5	M12	137	Fan cooled						
160	4160													579		1324	378	445	916	855	45.8
160	4160	3	579	1324	378	445	916	855	45.8	408	140	4.5	M12	185	Fan cooled						
160	4160													579		1324	378	445	916	855	45.8

Mounting to a Fully-Enclosed Panel (Internal Sink)

The heatsink arrangement for open chassis-type Inverters can be changed to an externally mounted heatsink arrangement, so that the Inverter can easily be installed inside the fully-enclosed panel. In such cases, make sure that the temperature inside the panel is in the following ranges.

Cooling Design for Fully-Closed Enclosure Panel

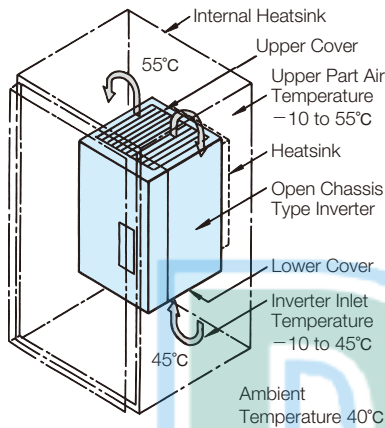

Mounting the External Heatsink

Remove the upper and lower covers for Inverters of 200/400 V 15 kW or less .

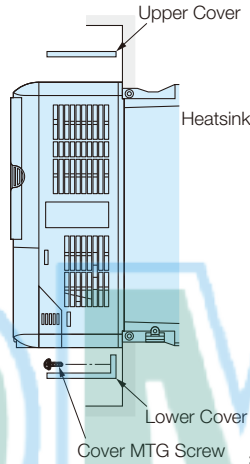

Ventilation Space

When installing 200/400 V Inverters of 18.5 kW or more in a panel, secure spaces for eyebolts on both sides of the Inverter and the main circuit wiring.

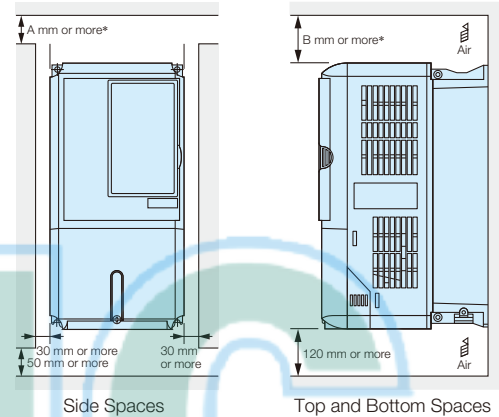

* Refer to the following specifications for securing spaces.
 When using the Inverters of 90 kW to 110 kW in the 200 V class or 132 kW to 220 kW in the 400 V class A : 120 B : 120
 When using the Inverter of 300 kW in the 400 V class A : 300 B : 300
 All other Inverters A : 50 B : 120
 With a fan on the ceiling of the enclosed cabinet for exhausting A : 50 B : 120

Inverter Heat Loss

200 V Class

Model	CIMR-G7A	20P4	20P7	21P5	22P2	23P7	25P5	27P5	2011	2015	2018	2022	2030	2037	2045	2055	2075	2090	2110	
Inverter Capacity	kVA	1.2	2.3	3.0	4.6	6.9	10	13	19	25	30	37	50	61	70	85	110	140	160	
Rated Current	A	3.2	6	8	12	18	27	34	49	66	80	96	130	160	183	224	300	358	415	
Heat Loss W	Fin	W	21	43	58	83	122	187	263	357	473	599	679	878	1080	1291	1474	2009	1963	2389
	Inside Unit	W	36	42	47	53	64	87	112	136	174	242	257	362	434	510	607	823	925	1194
	Total Heat Loss	W	57	85	105	136	186	274	375	493	647	839	936	1240	1514	1801	2081	2832	2888	3583
Fin Cooling			Self cooled				Fan cooled													

400 V Class

Model	CIMR-G7A	40P4	40P7	41P5	42P2	43P7	45P5	47P5	4011	4015	4018	4022	4030	4037	4045	4055	4075	4090	4110	4132	4160	4185	4220	4300	
Inverter Capacity	kVA	1.4	2.6	3.7	4.7	6.9	11	16	21	26	32	40	50	61	74	98	130	150	180	210	230	280	340	460	
Rated Current	A	1.8	3.4	4.8	6.2	9	15	21	27	34	42	52	65	80	97	128	165	195	240	270	302	370	450	605	
Heat Loss W	Fin	W	10	21	33	41	76	132	198	246	311	354	516	633	737	929	1239	1554	1928	2299	2612	3614	4436	5329	6749
	Inside Unit	W	39	44	46	49	64	79	106	116	135	174	210	246	285	340	488	596	762	928	1105	1501	1994	2205	2941
	Total Heat Loss	W	49	65	79	90	140	211	304	362	446	528	726	879	1022	1269	1727	2150	2690	3227	3717	5115	6430	7534	9690
Fin Cooling			Self cooled				Fan cooled																		

Attachments

Heatsink External Mounting Attachment

The Varispeed G7 Inverters under the 200/400 V class 15 kW or less need this attachment for mounting the heatsink externally. This attachment expands the outer dimensions of the width and height of the Inverter. (Attachment is not required for Inverters of 18.5 kW or more.)

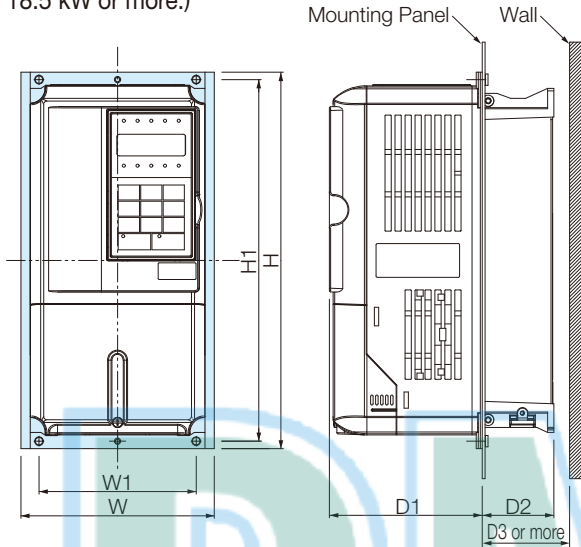

Model CIMR-G7A	Attachment Order Code	W	H	W1	H1	D1	D2	D3
20P4	EZZ08676A	155	302	126	290	122.6	37.4	40
20P7							57.4	60
21P5								
22P2								
23P7								
25P5	EZZ08676B	210	330	180	316	136.1	63.4	70
27P5								
2011	EZZ08676C	250	392	216	372	133.6	76.4	85
2015								
40P4							EZZ08676A	155
40P7	57.4	60						
41P5								
42P2								
43P7								
45P5	EZZ08676B	210	330	180	316	136.1	63.4	70
47P5								
4011	EZZ08676C	250	392	216	372	133.6	76.4	85
4015								

Panel Cut for External Mounting of Cooling Fin (Heatsink)

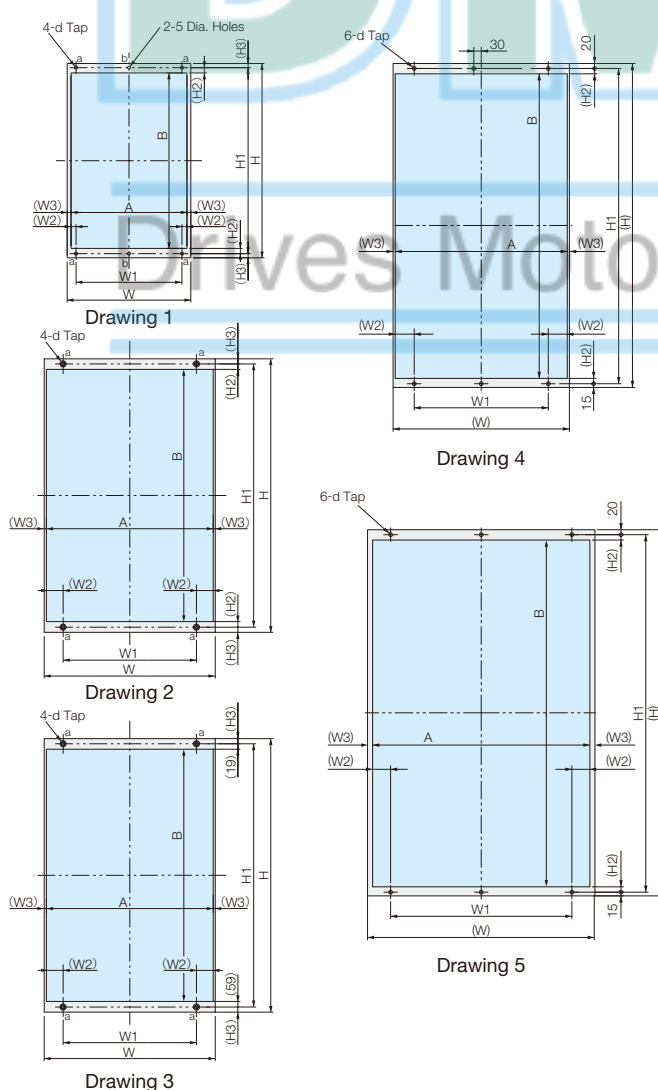

Model CIMR-G7A	Drawing	W	H	W1	(W2)	(W3)	H1	(H2)	(H3)	A	B	d
20P4	1	155	302	126	6	8.5	290	9.5	6	138	271	M5
20P7												
21P5												
22P2												
23P7												
25P5	2	210	330	180	8.5	6.5	316	9	7	197	298	
27P5												
2011	2	250	392	216	24.5	3	385	8	7.5	244	369	M6
2015												
2018												
2022	2	275	450	220	24.5	3	435	8	7.5	269	419	M6
2030												
2037												
2045												
2055												
2075	2	500	850	370	57	8	820	19	15	484	782	M12
2090												
2110	1	155	302	126	6	8.5	290	9.5	6	138	271	M5
40P4												
40P7												
41P5												
42P2												
43P7	2	210	330	180	8.5	6.5	316	9	7	197	298	
45P5												
47P5	2	250	392	216	24.5	3	435	8	7.5	269	419	M6
4011												
4015												
4018	2	275	450	220	24.5	3	435	8	7.5	269	419	M6
4022												
4030												
4037												
4045												
4055	2	450	725	325	54.5	8	700	13.5	12.5	434	673	M10
4075												
4090	2	500	850	370	57	8	820	19	15	484	782	M12
4110												
4132												
4160	3	575	925	445	55	10	895	*	15	555	817	M12
4185	4	710	1305	540	76.5	8.5	1270	21.5	*	693	1227	
4220	4	710	1305	540	76.5	8.5	1270	21.5	*	693	1227	
4300	5	916	1475	730	72.5	20.5	1440	21.5	*	875	1397	

* The sizes are different between the top and the bottom. Refer to Drawings 3 to 5.

Constants List

- How to read this list**
- Constants not described in this list are not displayed in the digital operator.
 - Setting constants vary in accordance with password setting (A1-04).
 - A, Q and × represent access level and capability.
 A : ADVANCED (when the advanced program mode is selected)
 Q : QUICK (when the quick program mode and the advanced mode are selected)
 × : Cannot be accessed.

Function	No.	Name	Setting Range	Minimum Setting Unit	Factory Setting	Online Changing	Control Mode					Ref. Page
							V/f without PG	V/f with PG	Open Loop Vector1	Flux Vector	Open Loop Vector2	
Initialize Mode	A1-00	Language selection for digital operator display	0 to 6	1	1	○	A	A	A	A	A	31
	A1-01	Constant access level	0 to 2	1	2	○	A	A	A	A	A	
	A1-02	Control method selection	0 to 4	1	2	×	Q	Q	Q	Q	Q	
	A1-03	Initialize	0 to 3330	1	0	×	A	A	A	A	A	
	A1-04	Password	0 to 9999	1	0	×	A	A	A	A	A	
	A1-05	Password setting	0 to 9999	1	0	×	A	A	A	A	A	
User-set Constants	A2-01 to A2-32	User setting constants	b1-01 to o3-02	—	—	×	A	A	A	A	A	31
Operation Mode Selections	b1-01	Reference selection	0 to 4	1	1	×	Q	Q	Q	Q	Q	35
	b1-02	Operation method selection	0 to 3	1	1	×	Q	Q	Q	Q	Q	
	b1-03	Stopping method selection	0 to 3*1	1	0	×	Q	Q	Q	Q	Q	46
	b1-04	Prohibition of reverse operation	0, 1	1	0	×	A	A	A	A	A	36
	b1-05	Operation selection for setting E1-09 or less	0 to 3	1	0	×	×	×	×	A	×	
	b1-06	Read sequence input twice	0, 1	1	1	×	A	A	A	A	A	—
	b1-07	Operation selection after switching to remote mode	0, 1	1	0	×	A	A	A	A	A	
	b1-08	Run command selection in programming modes	0 to 1, 2#	1	0	×	A	A	A	A	A	
	b1-10	Mode selection for zero speed	0, 1	1	0	×	×	×	×	×	A	
	DC Injection Braking	b2-01	Zero speed level (DC injection braking starting frequency)	0.0 to 10.0	0.1 Hz	0.5 Hz	×	A	A	A	A	A
b2-02		DC injection braking current	0 to 100	1%	50%	×	A	A	A	×	×	
b2-03		DC injection braking time at start	0.00 to 10.00	0.01 s	0.00 s	×	A	A	A	A	A	46
b2-04		DC injection braking time at stop	0.00 to 10.00	0.01 s	0.50 s	×	A	A	A	A	A	
b2-08		Magnetic flux compensation volume	0 to 1000	1%	0%	×	×	×	A	×	×	—
Speed Search	b3-01	Speed search selection	0 to 3	1	2*2	×	A	A	A	×	A	40
	b3-02	Speed search operating current (current detection)	0 to 200	1%	100%*2	×	A	×	A	×	A	
	b3-03	Speed search deceleration time (current detection)	0.1 to 10.0	0.1 s	2.0 s	×	A	×	A	×	×	
	b3-05	Speed search wait time	0.0 to 20.0	0.1 s	0.2 s	×	A	A	A	A	A	
	b3-10	Speed search detection compensation gain (speed calculation)	1.00 to 1.20	0.01	1.10	×	A	×	A	×	A	
	b3-13	Proportional gain of the speed estimator during speed search	0.1 to 2.0	0.1%	1.0%	×	×	×	×	×	A	
	b3-14	Rotation direction search selection	0, 1	1	1	×	A	A	A	×	A	
	b3-17#	Speed search retrial current level	0 to 200	1%	150%	×	A	×	A	×	A	
	b3-18#	Speed search retrial detection time	0.00 to 1.00	0.01 s	0.10 s	×	A	×	A	×	A	
	b3-19#	Number of speed search retrials	0 to 10	1	0	×	A	×	A	×	A	
Timer Function	b4-01	Timer function ON-delay time	0.0 to 300.0	0.1 s	0.0 s	×	A	A	A	A	A	48
	b4-02	Timer function OFF-delay time	0.0 to 300.0	0.1 s	0.0 s	×	A	A	A	A	A	
PID Control	b5-01	PID control mode selection	0 to 4	1	0	×	A	A	A	A	A	53
	b5-02	Proportional gain (P)	0.00 to 25.00	0.01	1.00	○	A	A	A	A	A	
	b5-03	Integral (I) time	0.0 to 360.0	0.1 s	1.0 s	○	A	A	A	A	A	
	b5-04	Integral (I) limit	0.0 to 100.0	0.1%	100.0%	○	A	A	A	A	A	
	b5-05	Derivative (D) time	0.00 to 10.00	0.01 s	0.00 s	○	A	A	A	A	A	
	b5-06	PID limit	0.0 to 100.0	0.1%	100.0%	○	A	A	A	A	A	
	b5-07	PID offset adjustment	-100.0 to +100.0	0.1%	0.0%	○	A	A	A	A	A	
	b5-08	PID primary delay time constant	0.00 to 10.00	0.01 s	0.00 s	○	A	A	A	A	A	
	b5-09	PID output characteristics selection	0, 1	1	0	×	A	A	A	A	A	
	b5-10	PID output gain	0.0 to 25.0	0.1	1.0	×	A	A	A	A	A	
	b5-11	PID reverse output selection	0, 1	1	0	×	A	A	A	A	A	
	b5-12	Selection of PID feedback command loss detection	0 to 2	1	0	×	A	A	A	A	A	
	b5-13	PID feedback command loss detection level	0 to 100	1%	0%	×	A	A	A	A	A	
	b5-14	PID feedback command loss detection time	0.0 to 25.5	0.1 s	1.0 s	×	A	A	A	A	A	
	b5-15	PID sleep function operation level	0.0 to 400.0	0.1 Hz	0.0 Hz	×	A	A	A	A	A	
	b5-16	PID sleep operation delay time	0.0 to 25.5	0.1 s	0.0 s	×	A	A	A	A	A	
	b5-17	Accel/decel time for PID reference	0.0 to 25.5	0.1 s	0.0 s	×	A	A	A	A	A	

#: The constants are available only for version PRG: 1039 or later.

The settings and control modes marked with # are also available for version PRG: 1039 or later.

*1: The setting range is 0 or 1 for flux vector control and open-loop vector control 2.

*2: The factory setting will change when the control method (A1-02) is changed. (Open-loop vector 1 factory settings are given.)

Function	No.	Name	Setting Range	Minimum Setting Unit	Factory Setting	Online Changing	Control Mode					Ref. Page			
							V/f without PG	V/f with PG	Open Loop Vector1	Flux Vector	Open Loop Vector2				
Dwell Functions	b6-01	Dwell frequency at start	0.0 to 400.0	0.1 Hz	0.0 Hz	×	A	A	A	A	A	—			
	b6-02	Dwell time at start	0.0 to 10.0	0.1 s	0.0 s	×	A	A	A	A	A				
	b6-03	Dwell frequency at stop	0.0 to 400.0	0.1 Hz	0.0 Hz	×	A	A	A	A	A				
	b6-04	Dwell time at stop	0.0 to 10.0	0.1 s	0.0 s	×	A	A	A	A	A				
DROOP Control	b7-01	Droop control gain	0.0 to 100.0	0.1%	0.0%	○	×	×	×	A	A	—			
	b7-02	Droop control delay time	0.03 to 2.00	0.01 s	0.05 s	○	×	×	×	A	A				
Energy Saving	b8-01	Energy-saving mode selection	0, 1	1	0	×	A	A	A	A	A	55			
	b8-02	Energy-saving gain	0.0 to 10.0	0.1	0.7*1	○	×	×	A	A	A				
	b8-03	Energy-saving filter time constant	0.00 to 10.00	0.01 s	0.50 s*2	○	×	×	A	A	A				
	b8-04	Energy-saving coefficient	0.00 to 655.00	0.01	*1 *3	×	A	A	×	×	×				
	b8-05	Power detection filter time constant	0 to 2000	1 ms	20 ms	×	A	A	×	×	×				
	b8-06	Search operation voltage limiter	0 to 100	1%	0%	×	A	A	×	×	×				
Zero Servo	b9-01	Zero-servo gain	0 to 100	1	5	×	×	×	×	A	×	—			
	b9-02	Zero-servo completion width	0 to 16383	1	10	×	×	×	×	A	×				
Acceleration /Deceleration	C1-01	Acceleration time 1	0.0 to 6000.0*4	0.1 s	10.0 s	○	Q	Q	Q	Q	Q	34 37			
	C1-02	Deceleration time 1				○	Q	Q	Q	Q	Q		Q		
	C1-03	Acceleration time 2				○	A	A	A	A	A		A		
	C1-04	Deceleration time 2				○	A	A	A	A	A		A		
	C1-05	Acceleration time 3				×	A	A	A	A	A		A		
	C1-06	Deceleration time 3				×	A	A	A	A	A		A		
	C1-07	Acceleration time 4				×	A	A	A	A	A		A		
	C1-08	Deceleration time 4				×	A	A	A	A	A		A		
	C1-09	Emergency stop time				×	A	A	A	A	A		A		
	C1-10	Accel/decel time setting unit				0, 1	1	1	×	A	A		A	A	A
	C1-11	Accel/decel time switching frequency				0.0 to 400.0	0.1 Hz	0.0 Hz	×	A	A		A	A	A
S-curve Acceleration /Deceleration	C2-01	S-curve characteristic time at acceleration start	0.00 to 2.50	0.01 s	0.20 s	×	A	A	A	A	A	37			
	C2-02	S-curve characteristic time at acceleration end	0.00 to 2.50	0.01 s	0.20 s	×	A	A	A	A	A				
	C2-03	S-curve characteristic time at deceleration start	0.00 to 2.50	0.01 s	0.20 s	×	A	A	A	A	A				
	C2-04	S-curve characteristic time at deceleration end	0.00 to 2.50	0.01 s	0.00 s	×	A	A	A	A	A				
Motor Slip Compensation	C3-01	Slip compensation gain	0.0 to 2.5	0.1	1.0*5	○	A	×	A	A	A	51			
	C3-02	Slip compensation primary delay time	0 to 10000	1 ms	200 ms*5	×	A	×	A	×	×				
	C3-03	Slip compensation limit	0 to 250	1%	200%	×	A	×	A	×	×				
	C3-04	Slip compensation selection during regeneration	0, 1	1	0	×	A	×	A	×	×				
	C3-05	Output voltage control limit selection	0, 1	1	0	×	×	×	A	A	A				
Torque Compensation	C4-01	Torque compensation gain	0.00 to 2.50	0.01	1.00	○	A	A	A	×	×	49			
	C4-02	Torque compensation primary delay time constant	0 to 10000	1 ms	20 ms*5	×	A	A	A	×	×				
	C4-03	Forward starting torque	0.0 to 200.0	0.1%	0.0%	×	×	×	A	×	×				
	C4-04	Reverse starting torque	-200.0 to 0.0	0.1%	0.0%	×	×	×	A	×	×				
	C4-05	Starting torque time constant	0 to 200	1 ms	10 ms	×	×	×	A	×	×				
Speed Control (ASR)	C5-01	ASR proportional (P) gain 1	0.00 to 300.00*7	0.01	20.00*6	○	×	A	×	A	A	51			
	C5-02	ASR integral (I) time 1	0.000 to 10.000	0.001 s	0.500 s*6	○	×	A	×	A	A				
	C5-03	ASR proportional (P) gain 2	0.00 to 300.00*7	0.01	20.00*6	○	×	A	×	A	A				
	C5-04	ASR integral (I) time 2	0.000 to 10.000	0.001 s	0.500 s*6	○	×	A	×	A	A				
	C5-05	ASR limit	0.0 to 20.0	0.1%	5.0%	×	×	A	×	×	×				
	C5-06	ASR primary delay time	0.000 to 0.500	0.001 s	0.004 s*6	×	×	×	×	A	A				
	C5-07	ASR switching frequency	0.0 to 400.0	0.1 Hz	0.0 Hz	×	×	×	×	A	A				
	C5-08	ASR integral (I) limit	0 to 400	1%	400%	×	×	×	×	A	A				
	C5-09	ASR primary delay time 1	0.000 to 0.500	0.001 s	0.004 s*6	×	×	×	×	A	A				
	C5-10	ASR primary delay time 2	0.000 to 0.500	0.001	0.010 s	×	×	×	×	×	A				

*1: The factory setting is 1.0 when using flux vector control.

*2: When Inverter capacity is 55 kW min., the factory settings are 0.05 s for flux vector control and 2.00 s for open-loop vector control 2.

The factory setting will change when the control method (A1-02) is changed. (Open-loop vector 1 factory settings are given.)

*3: The same capacity as the Inverter will be set by initializing the constants.

*4: The setting range for acceleration/deceleration times will depends on the setting for C1-10. When C1-10 is set to 0, the setting range for acceleration/ deceleration times becomes 0.00 to 600.00 s.

*5: The factory setting will change when the control method (A1-02) is changed. (Open-loop vector 1 factory settings are given.)

*6: The factory setting will change when the control method (A1-02) is changed. (Flux vector factory settings are given.)

*7: The setting range is 1.00 to 300.0 for flux vector control and open-loop vector control 2.

Function	No.	Name	Setting Range	Minimum Setting Unit	Factory Setting	Online Changing	Control Mode					Ref. Page	
							V/f without PG	V/f with PG	Open Loop Vector1	Flux Vector	Open Loop Vector2		
Carrier Frequency	C6-02	Carrier frequency selection	1 to F*1	1	6*2	×	Q	Q	Q	Q	×	44	
	C6-03	Carrier frequency upper limit	2.0 to 15.0*3*4	0.1 kHz	15.0 kHz*2	×	A	A	A	A	×	—	
	C6-04	Carrier frequency lower limit	0.4 to 15.0*3*4	0.1 kHz	15.0 kHz*2	×	A	A	×	×	×		
	C6-05	Carrier frequency proportional gain	00 to 99*4	1	0	×	A	A	×	×	×		
	C6-11	Carrier frequency selection for open-loop vector control 2	1 to 4	1	1*9	×	*5 ×	*5 ×	*5 ×	*5 ×	Q		
Preset Reference	d1-01	Frequency reference 1	0 to 400.00*6	0.01 Hz*7	0.00 Hz	○	Q	Q	Q	Q	Q		36
	d1-02	Frequency reference 2				○	Q	Q	Q	Q	Q	Q	
	d1-03	Frequency reference 3				○	Q	Q	Q	Q	Q	Q	
	d1-04	Frequency reference 4				○	Q	Q	Q	Q	Q	Q	
	d1-05	Frequency reference 5				○	A	A	A	A	A	A	
	d1-06	Frequency reference 6				○	A	A	A	A	A	A	
	d1-07	Frequency reference 7				○	A	A	A	A	A	A	
	d1-08	Frequency reference 8				○	A	A	A	A	A	A	
	d1-09	Frequency reference 9				○	A	A	A	A	A	A	
	d1-10	Frequency reference 10				○	A	A	A	A	A	A	
	d1-11	Frequency reference 11				○	A	A	A	A	A	A	
	d1-12	Frequency reference 12				○	A	A	A	A	A	A	
	d1-13	Frequency reference 13				○	A	A	A	A	A	A	
	d1-14	Frequency reference 14				○	A	A	A	A	A	A	
	d1-15	Frequency reference 15				○	A	A	A	A	A	A	
	d1-16	Frequency reference 16				○	A	A	A	A	A	A	
	d1-17	Jog frequency reference				0 to 400.00*6	0.01 Hz*7	6.00 Hz	○	Q	Q	Q	
Reference Limits	d2-01	Frequency reference upper limit	0.0 to 110.0	0.1%	100.0%	×	A	A	A	A	A	38	
	d2-02	Frequency reference lower limit	0.0 to 110.0	0.1%	0.0%	×	A	A	A	A	A		
	d2-03	Master-speed reference lower limit	0.0 to 110.0	0.1%	0.0%	×	A	A	A	A	A		
Jump Frequency	d3-01	Jump frequency 1	0.0 to 400.0	0.1 Hz	0.0 Hz	×	A	A	A	A	A	38	
	d3-02	Jump frequency 2		0.1 Hz	0.0 Hz	×	A	A	A	A	A		
	d3-03	Jump frequency 3		0.1 Hz	0.0 Hz	×	A	A	A	A	A		
	d3-04	Jump frequency width		0.0 to 20.0	0.1 Hz	1.0 Hz	×	A	A	A	A		A
Reference Frequency Hold	d4-01	Frequency reference hold function selection	0, 1	1	0	×	A	A	A	A	A	41	
	d4-02	+ – Speed limits	0 to 100	1%	10%	×	A	A	A	A	A	—	
Torque Control	d5-01	Torque control selection	0, 1	1	0	×	×	×	×	A	A	—	
	d5-02	Torque reference delay time	0 to 1000	1 ms	0 ms*8	×	×	×	×	A	A		
	d5-03	Speed limit selection	1, 2	1	1	×	×	×	×	A	A		
	d5-04	Speed limit	-120 to +120	1%	0%	×	×	×	×	A	A		
	d5-05	Speed limit bias	0 to 120	1%	10%	×	×	×	×	A	A		
	d5-06	Speed/torque control switching timer	0 to 1000	1 ms	0 ms	×	×	×	×	A	A		
	d5-07	Rotation direction limit operation selection	0, 1	1	1	×	×	×	×	×	A		
Field Weakening	d6-01	Field weakening level	0 to 100	1%	80%	×	A	A	×	×	×	—	
	d6-02	Field frequency	0.0 to 400.0	0.1 Hz	0.0 Hz	×	A	A	×	×	×		
	d6-03	Field forcing function selection	0, 1	1	0	×	×	×	A	A	A		
	d6-05	A ϕ R time constant	0.00 to 10.00	0.01	1.00	×	×	×	×	×	A		
	d6-06	Field forcing limit	100 to 400	1%	400%	×	×	×	A	A	A		

*1: The setting range depends on the capacity of the Inverter (o2-04). If the carrier frequency is set higher than the factory setting for Inverters with outputs of 5.5 kW or more, the Inverter rated current will need to be reduced.

*2: The factory setting depends on the capacity of the Inverter (o2-04). The value for a 200 V class Inverter of 0.4 kW is given.

*3: The setting range depends on the capacity of the Inverter (o2-04). The maximum output frequency depends on the setting for the carrier frequency.

*4: This constant can be monitored or set only when F is set for C6-02.

*5: Displayed in Quick Programming mode when motor 2 is set for a multi-function input.

*6: The setting range is 0 to 66.0 for open-loop vector control 2.

*7: The unit is set in o1-03.

*8: The factory setting will change when the control method (A1-02) is changed. (Flux vector factory settings are given.)

*9: This factory setting is for version PRG: 1040 or later. For version 1039 or earlier, the factory setting depends on the capacity of the Inverter (o2-04).

Function	No.	Name	Setting Range	Minimum Setting Unit	Factory Setting	Online Changing	Control Mode					Ref. Page
							V/f without PG	V/f with PG	Open Loop Vector1	Flux Vector	Open Loop Vector2	
V/f Pattern	E1-01	Input voltage setting	155 to 255*1	1 V	200 V*1	×	Q	Q	Q	Q	Q	31 33 34
	E1-03	V/f pattern selection	0 to F	1	F	×	Q	Q	×	×	×	
	E1-04	Max. output frequency	40.0 to 400.0*2	0.1 Hz	60.0 Hz*3	×	Q	Q	Q	Q	Q	
	E1-05	Max. voltage	0.0 to 255.0*1	0.1 V	200.0 V*1*3	×	Q	Q	Q	Q	Q	
	E1-06	Base frequency	0.0 to 400.0*2	0.1 Hz	60.0 Hz*3	×	Q	Q	Q	Q	Q	
	E1-07	Mid. output frequency	0.0 to 400.0	0.1 Hz	3.0 Hz*3	×	A	A	A	×	×	
	E1-08	Mid. output frequency voltage	0.0 to 255.0*1	0.1 V	11.0 V*1*3	×	A	A	A	×	×	
	E1-09	Min. output frequency	0.0 to 400.0*2	0.1 Hz	0.5 Hz*3	×	Q	Q	Q	A	Q	
	E1-10	Min. output frequency voltage	0.0 to 255.0*1	0.1 V	2.0 V*1*3	×	A	A	A	×	×	
	E1-11	Mid. output frequency 2	0.0 to 400.0*2	0.1 Hz	0.0 Hz*4	×	A	A	A	A	A	
	E1-12	Mid. output frequency voltage 2	0.0 to 255.0*1	0.1 V	0.0 V*4	×	A	A	A	A	A	
	E1-13	Base voltage	0.0 to 255.0*1	0.1 V	0.0 V*5	×	A	A	Q	Q	Q	
	Motor Setup	E2-01	Motor rated current	0.32 to 6.40*6	0.01 A	1.90 A*7	×	Q	Q	Q	Q	
E2-02		Motor rated slip	0.00 to 20.00	0.01 Hz	2.90 Hz*7	×	A	A	A	A	A	
E2-03		Motor no-load current	0.00 to 1.89*8	0.01 A	1.20 A*7	×	A	A	A	A	A	
E2-04		Number of motor poles	2 to 48	2 pole	4 pole	×	×	Q	×	Q	Q	
E2-05		Motor line-to-line resistance	0.000 to 65.000	0.001 Ω	9.842 Ω*7	×	A	A	A	A	A	
E2-06		Motor leak inductance	0.0 to 40.0	0.1%	18.2%*7	×	×	×	A	A	A	
E2-07		Motor iron saturation coefficient 1	0.00 to 0.50	0.01	0.50	×	×	×	A	A	A	
E2-08		Motor iron saturation coefficient 2	0.50 to 0.75	0.01	0.75	×	×	×	A	A	A	
E2-09		Motor mechanical loss	0.0 to 10.0		0.0	×	×	×	A	A	A	
E2-10		Motor iron loss for torque compensation	0 to 65535	1 W	14 W*7	×	A	A	×	×	×	
E2-11		Motor rated output	0.00 to 650.00	0.01 kW	0.4 kW*9	×	Q	Q	Q	Q	Q	
E2-12		Motor iron saturation coefficient 3	1.30 to 1.60*10	0.01	1.30	×	×	×	A	A	A	
Motor 2 V/f Pattern	E3-01	Motor 2 control method selection	0 to 4	1	2	×	A	A	A	A	A	—
	E3-02	Motor 2 max. output frequency (FMAX)	40.0 to 400.0*11	0.1 Hz	60.0 Hz	×	A	A	A	A	A	
	E3-03	Motor 2 max. voltage (VMAX)	0.0 to 255.0*1	0.1 V	200.0 V*3	×	A	A	A	A	A	
	E3-04	Motor 2 max. voltage frequency (FA)	0.0 to 400.0	0.1 Hz	60.0 Hz	×	A	A	A	A	A	
	E3-05	Motor 2 mid. output frequency (FB)	0.0 to 400.0	0.1 Hz	3.0 Hz*3	×	A	A	A	F	F	
	E3-06	Motor 2 mid. output frequency voltage (VC)	0.0 to 255.0*1	0.1 V	11.0 V*1*3	×	A	A	A	F	F	
	E3-07	Motor 2 min. output frequency (FMIN)	0.0 to 400.0	0.1 Hz	0.5 Hz*3	×	A	A	A	A	A	
	E3-08	Motor 2 min. output frequency voltage (VMIN)	0.0 to 255.0*1	0.1 V	2.0 V*1*3	×	A	A	A	F	F	
Motor 2 Setup	E4-01	Motor 2 rated current	0.32 to 6.40*6	0.01 A	1.90 A*7	×	A	A	A	A	A	—
	E4-02	Motor 2 rated slip	0.00 to 20.00	0.01 Hz	2.90 Hz*7	×	A	A	A	A	A	
	E4-03	Motor 2 no-load current	0.00 to 1.89*8	0.01 A	1.20 A*7	×	A	A	A	A	A	
	E4-04	Motor 2 number of poles	2 to 48	2 pole	4 pole	×	×	A	×	A	A	
	E4-05	Motor 2 line-to-line resistance	0.000 to 65.000	0.001 Ω	9.842 Ω*7	×	A	A	A	A	A	
	E4-06	Motor 2 leak inductance	0.0 to 40.0	0.1%	18.2%*7	×	×	×	A	A	A	
	E4-07	Motor 2 rated capacity	0.40 to 650.00	0.01 kW	0.40 kW*7	×	A	A	A	A	A	
PG Option Setup	F1-01	PG constant	0 to 60000	1	600	×	×	Q	×	Q	×	—
	F1-02	Operation selection at PG open circuit (PGO)	0 to 3	1	1	×	×	A	×	A	×	
	F1-03	Operation selection at overspeed	0 to 3	1	1	×	×	A	×	A	A	
	F1-04	Operation selection at deviation	0 to 3	1	3	×	×	A	×	A	A	
	F1-05	PG rotation	0, 1	1	0	×	×	A	×	A	×	
	F1-06	PG division rate (PG pulse monitor)	1 to 132	1	1	×	×	A	×	A	×	
	F1-07	Integral value during accel/decel enable/disable	0, 1	1	0	×	×	A	×	×	×	

*1: There are values for a 200 V class Inverter. Values for a 400 V class Inverter are double.
 *2: The setting range for open-loop vector 2 control is 0 to 66.0 (0 to 132.0 for PRG: 103 □). The maximum output frequency of the 400 V-class Inverter is restricted by the setting of carrier frequency and its capacity. The maximum output frequency is 250 Hz for 90 kW to 110 kW and 166 Hz for 132 kW to 300 kW Inverters in the 400 V class.
 *3: The factory setting will change when the control method (A1-02) is changed. (Open-loop vector 1 factory settings are given.)
 *4: E1-11 and E1-12 are disregarded when set to 0.0.
 *5: When E1-13 (Base voltage) is set to 0.0, the output voltage is controlled with E1-05 (Maximum voltage) = E1-13. When autotuning is performed, E1-05 and E1-13 are automatically set to the same value.
 *6: The setting range is 10% to 200% of the Inverter's rated output current. The value for a 200 V class Inverter of 0.4 kW is given.
 *7: The factory setting depends on the capacity of the Inverter (o2-04). The value for a 200 V class Inverter of 0.4 kW is given.
 *8: The setting range depends on the capacity of the Inverter (o2-04). The value for a 200 V class Inverter of 0.4 kW is given.
 *9: The same capacity as the Inverter will be set by initializing the constants.
 *10: This constant is automatically set during autotuning.
 *11: The setting range for open-loop vector 2 control is 0 to 66.0 (0 to 132.0 for PRG: 103 □).
 *12: The factory setting will change when the control method (A1-02) is changed. (Flux vector factory settings are given.)

Function	No.	Name	Setting Range	Minimum Setting Unit	Factory Setting	Online Changing	Control Mode					Ref. Page
							V/f without PG	V/f with PG	Open Loop Vector1	Flux Vector	Open Loop Vector2	
PG Option Setup	F1-08	Overspeed detection level	0 to 120	1%	115%	×	×	A	×	A	A	—
	F1-09	Overspeed detection delay time	0.0 to 2.0	0.1 s	0.0 s*1	×	×	A	×	A	A	
	F1-10	Excessive speed deviation detection level	0 to 50	1%	10%	×	×	A	×	A	A	
	F1-11	Excessive speed deviation detection delay time	0.0 to 10.0	0.1 s	0.5 s	×	×	A	×	A	A	
	F1-12	Number of PG gear teeth 1	0 to 1000	1	0	×	×	A	×	×	×	
	F1-13	Number of PG gear teeth 2		1	0	×	×	A	×	×	×	
	F1-14	PG open-circuit detection time	0.0 to 10.0	0.1 s	2.0 s	×	×	A	×	A	×	
Analog Reference Card	F2-01	Bi-polar or uni-polar input selection	0, 1	1	0	×	A	A	A	A	A	—
Digital Reference Card	F3-01	Digital input option	0 to 7	1	0	×	A	A	A	A	A	—
Analog Monitor Card	F4-01	Channel 1 monitor selection	1 to 50	1	2	×	A	A	A	A	A	—
	F4-02	Channel 1 gain	0.00 to 2.50	0.01	1.00	○	A	A	A	A	A	
	F4-03	Channel 2 monitor selection	1 to 50	1	3	×	A	A	A	A	A	
	F4-04	Channel 2 gain	0.00 to 2.50	0.01	0.5	○	A	A	A	A	A	
	F4-05	Channel 1 output monitor bias	-10.0 to 10.0	0.1	0.0	○	A	A	A	A	A	
	F4-06	Channel 2 output monitor bias	-10.0 to 10.0	0.1	0.0	○	A	A	A	A	A	
	F4-07	Analog output signal level for channel 1	0, 1	1	0	×	A	A	A	A	A	
	F4-08	Analog output signal level for channel 2	0, 1	1	0	×	A	A	A	A	A	
Digital Output Card	F5-01	Channel 1 output selection	0 to 37	1	0	×	A	A	A	A	A	—
	F5-02	Channel 2 output selection	0 to 37	1	1	×	A	A	A	A	A	
	F5-03	Channel 3 output selection	0 to 37	1	2	×	A	A	A	A	A	
	F5-04	Channel 4 output selection	0 to 37	1	4	×	A	A	A	A	A	
	F5-05	Channel 5 output selection	0 to 37	1	6	×	A	A	A	A	A	
	F5-06	Channel 6 output selection	0 to 37	1	37	×	A	A	A	A	A	
	F5-07	Channel 7 output selection	0 to 37	1	0F	×	A	A	A	A	A	
	F5-08	Channel 8 output selection	0 to 37	1	0F	×	A	A	A	A	A	
	F5-09	DO-08 output mode selection	0 to 2	1	0	×	A	A	A	A	A	
Communications Option Card	F6-01	Operation selection after communications error	0 to 3	1	1	×	A	A	A	A	A	—
	F6-02	Input level of external fault from Communications Option Card	0, 1	1	0	×	A	A	A	A	A	
	F6-03	Stopping method for external fault from Communications Option Card	0 to 3	1	1	×	A	A	A	A	A	
	F6-04	Trace sampling from Communications Option Card	0 to 60000	1	0	×	A	A	A	A	A	
	F6-05	Torque reference/torque limit selection from Communications Option Card	0, 1	1	1	×	×	×	×	A	A	
	F6-06	Torque reference/torque limit selection from Communications Option Card	0, 1	1	0	×	×	×	×	A	A	
	F6-08	Operation selection after SI-T WDT error	0 to 3	1	1	×	A	A	A	A	A	
	F6-09	Number of SI-T BUS error detection	2 to 10	1	2	×	A	A	A	A	A	
Multi-function Contact Inputs	H1-01	Terminal S3 function selection	0 to 79	1	24	×	A	A	A	A	A	36 47 48
	H1-02	Terminal S4 function selection	0 to 79	1	14	×	A	A	A	A	A	
	H1-03	Terminal S5 function selection	0 to 79	1	3 (0)*2	×	A	A	A	A	A	
	H1-04	Terminal S6 function selection	0 to 79	1	4 (3)*2	×	A	A	A	A	A	
	H1-05	Terminal S7 function selection	0 to 79	1	6 (4)*2	×	A	A	A	A	A	
	H1-06	Terminal S8 function selection	0 to 79	1	8 (6)*2	×	A	A	A	A	A	
	H1-07	Terminal S9 function selection	0 to 79	1	5	×	A	A	A	A	A	
	H1-08	Terminal S10 function selection	0 to 79	1	32	×	A	A	A	A	A	
	H1-09	Terminal S11 function selection	0 to 79	1	7	×	A	A	A	A	A	
	H1-10	Terminal S12 function selection	0 to 79	1	15	×	A	A	A	A	A	
Multi-function Contact Outputs	H2-01	Terminal M1-M2 function selection (contact)	0 to 37	1	0	×	A	A	A	A	A	48
	H2-02	Terminal P1 function selection (open collector)	0 to 37	1	1	×	A	A	A	A	A	
	H2-03	Terminal P2 function selection (open collector)	0 to 37	1	2	×	A	A	A	A	A	
	H2-04	Terminal P3 function selection (open collector)	0 to 37	1	6	×	A	A	A	A	A	
	H2-05	Terminal P4 function selection (open collector)	0 to 37	1	10	×	A	A	A	A	A	

*1: The factory setting will change when the control method (A1-02) is changed. (Flux vector factory settings are given.)

*2: The values in parentheses indicate initial values when initialized in 3-wire sequence.

Function	No.	Name	Setting Range	Minimum Setting Unit	Factory Setting	Online Changing	Control Mode					Ref. Page
							V/f without PG	V/f with PG	Open Loop Vector1	Flux Vector	Open Loop Vector2	
Multi-function Analog Inputs	H3-01	Signal level selection (terminal A1)	0, 1	1	0	×	A	A	A	A	A	39
	H3-02	Gain (terminal A1)	0.0 to 1000.0	0.1%	100.0%	○	A	A	A	A	A	
	H3-03	Bias (terminal A1)	-100.0 to +100.0	0.1%	0.0%	○	A	A	A	A	A	
	H3-04	Signal level selection (terminal A3)	0, 1	1	0	×	A	A	A	A	A	
	H3-05	Multi-function analog input (terminal A3)	0 to 1F	1	2	×	A	A	A	A	A	
	H3-06	Gain (terminal A3)	0.0 to 1000.0	0.1%	100.0%	○	A	A	A	A	A	
	H3-07	Bias (terminal A3)	-100.0 to +100.0	0.1%	0.0%	○	A	A	A	A	A	
	H3-08	Multi-function analog input terminal A2 signal level selection	0 to 2	1	2	×	A	A	A	A	A	
	H3-09	Multi-function analog input terminal A2 function selection	0 to 1F	1	0	×	A	A	A	A	A	
	H3-10	Gain (terminal A2)	0.0 to 1000.0	0.1%	100.0%	○	A	A	A	A	A	
	H3-11	Bias (terminal A2)	-100.0 to +100.0	0.1%	0.0%	○	A	A	A	A	A	
	H3-12	Analog input filter time constant	0.00 to 2.00	0.01 s	0.03 s	×	A	A	A	A	A	
Multi-function Analog Outputs	H4-01	Monitor selection (terminal FM)	1 to 50	1	2	×	A	A	A	A	A	44 45
	H4-02	Gain (terminal FM)*1	0.00 to 2.50	0.01	1.00	○	Q	Q	Q	Q	Q	
	H4-03	Bias (terminal FM)*1	-10.0 to +10.0	0.1%	0.0%	○	A	A	A	A	A	
	H4-04	Monitor selection (terminal AM)	1 to 50	1	3	×	A	A	A	A	A	
	H4-05	Gain (terminal AM)*1	0.00 to 2.50	0.01	0.50	○	Q	Q	Q	Q	Q	
	H4-06	Bias (terminal AM)*1	-10.0 to +10.0	0.1%	0.0%	○	A	A	A	A	A	
	H4-07	Analog output 1 signal level selection	0, 1	1	0	×	A	A	A	A	A	
	H4-08	Analog output 2 signal level selection	0, 1	1	0	×	A	A	A	A	A	
MEMOBUS Communications	H5-01	Slave address	0 to 20*2	1	1F	×	A	A	A	A	A	54
	H5-02	Communication speed selection	0 to 4	1	3	×	A	A	A	A	A	
	H5-03	Communication parity selection	0 to 2	1	0	×	A	A	A	A	A	
	H5-04	Stopping method after communication error	0 to 3	1	3	×	A	A	A	A	A	
	H5-05	Communication error detection selection	0, 1	1	1	×	A	A	A	A	A	
	H5-06	Send wait time	5 to 65	1 ms	5 ms	×	A	A	A	A	A	
	H5-07	RTS control ON/OFF	0, 1	1	1	×	A	A	A	A	A	
	H5-10#	Unit Selection for MEMOBUS Register 0025H	0, 1	1	0	×	A	A	A	A	A	
Pulse Train I/O	H6-01	Pulse train input function selection	0 to 2	1	0	×	A	A	A	A	A	38 — 45
	H6-02	Pulse train input scaling	1000 to 32000	1 Hz	1440 Hz	○	A	A	A	A	A	
	H6-03	Pulse train input gain	0.0 to 1000.0	0.1%	100.0%	○	A	A	A	A	A	
	H6-04	Pulse train input bias	-100.0 to +100.0	0.1%	0.0%	○	A	A	A	A	A	
	H6-05	Pulse train input filter time	0.00 to 2.00	0.01 s	0.10 s	○	A	A	A	A	A	
	H6-06	Pulse train monitor selection	1, 2, 5, 20, 24, 36 only	1	2	○	A	A	A	A	A	
	H6-07	Pulse train monitor scaling	0 to 32000	1 Hz	1440 Hz	○	A	A	A	A	A	
Motor Overload	L1-01	Motor protection selection	0 to 3	1	1	×	Q	Q	Q	Q	Q	52 —
	L1-02	Motor protection time constant	0.1 to 5.0	0.1 min	1.0 min	×	A	A	A	A	A	
	L1-03	Alarm operation selection during motor overheating	0 to 3	1	3	×	A	A	A	A	A	
	L1-04	Motor overheating operation selection	0 to 2	1	1	×	A	A	A	A	A	
	L1-05	Motor temperature input filter time constant	0.00 to 10.00	0.01 s	0.20 s	×	A	A	A	A	A	
Power Loss Ridethrough	L2-01	Momentary power loss detection	0 to 2	1	0	×	A	A	A	A	A	40 —
	L2-02	Momentary power loss ridethru time	0 to 25.5	0.1 s	0.1 s*3	×	A	A	A	A	A	
	L2-03	Min. baseblock time	0.1 to 5.0	0.1 s	0.2 s*3	×	A	A	A	A	A	
	L2-04	Voltage recovery time	0.0 to 5.0	0.1 s	0.3 s*3	×	A	A	A	A	A	
	L2-05	Undervoltage detection level	150 to 210*4	1 V	190 V*4	×	A	A	A	A	A	
	L2-06	KEB deceleration time	0.0 to 200.0	0.1 s	0.0 s	×	A	A	A	A	A	
	L2-07	Momentary recovery time	0.0 to 25.5	0.1 s	0.0 s*5	×	A	A	A	A	A	
	L2-08	Frequency reduction gain at KEB start	0 to 300	1	100%	×	A	A	A	A	A	

#: The constants are available only for version PRG: 1039 or later.

The settings and control modes marked with # are also available for version PRG: 1039 or later.

*1: While the Inverter is stopped, the output voltage for the output channels 1 and 2 can be adjusted in the quick programming mode, the advanced programming mode, or the verify mode. The output channel 1 can be adjusted while the data setting display for H4-02 or H4-03 is monitored. The output channel 2 can be adjusted while the data setting display for H4-05 or H4-06 is monitored. The following voltage will be output. 100% monitor output × output gain + output bias

*2: Set H5-01 to 0 to disable Inverter response to MEMOBUS communications.

*3: The factory setting depends on the capacity of the Inverter (o2-04). The value for a 200 V class Inverter of 0.4 kW is given.

For 0.4 to 7.5 kW Inverters, a momentary power loss recovery unit (optional) can be added to ride through momentary power losses of up to 2.0 seconds.

*4: There are values for a 200 V class Inverter. Values for a 400 V class Inverter are double.

*5: If the setting is 0, the axis will accelerate to the specified speed over the specified acceleration time (C1-01 to C1-08).

Function	No.	Name	Setting Range	Minimum Setting Unit	Factory Setting	Online Changing	Control Mode					Ref. Page
							V/f without PG	V/f with PG	Open Loop Vector1	Flux Vector	Open Loop Vector2	
Stall Prevention	L3-01	Stall prevention selection during accel	0 to 2	1	1	×	A	A	A	×	×	50
	L3-02	Stall prevention level during accel	0 to 200	1%	150%	×	A	A	A	×	×	
	L3-03	Stall prevention limit during accel	0 to 100	1%	50%	×	A	A	A	×	×	
	L3-04	Stall prevention selection during decel	0 to 3*1	1	1	×	Q	Q	Q	Q	Q	
	L3-05	Stall prevention selection during running	0 to 2	1	1	×	A	A	×	×	×	
	L3-06	Stall prevention level during running	30 to 200	1%	160%	×	A	A	×	×	×	
	L3-11	Overvoltage inhibit selection	0, 1	1	0	×	×	×	A	A	A	
L3-12	Overvoltage inhibit voltage level	350 to 390	1 V	380 V	×	×	×	A	A	A	—	
Reference Detection	L4-01	Speed agree detection level	0.0 to 400.0	0.1 Hz	0.0 Hz	×	A	A	A	A	A	43
	L4-02	Speed agree detection width	0.0 to 20.0	0.1 Hz	2.0 Hz	×	A	A	A	A	A	
	L4-03	Speed agree detection level (+/-)	-400.0 to +400.0	0.1 Hz	0.0 Hz	×	A	A	A	A	A	
	L4-04	Speed agree detection width (+/-)	0.0 to 20.0	0.1 Hz	2.0 Hz	×	A	A	A	A	A	
	L4-05	Operation when frequency reference is missing	0, 1	1	0	×	A	A	A	A	A	
Fault Restart	L5-01	Number of auto restart attempts	0 to 10	1	0	×	A	A	A	A	A	41
	L5-02	Auto restart operation selection	0, 1	1	0	×	A	A	A	A	A	
Torque Detection	L6-01	Torque detection selection 1	0 to 8	1	0	×	A	A	A	A	A	42
	L6-02	Torque detection level 1	0 to 300	1%	150%	×	A	A	A	A	A	
	L6-03	Torque detection time 1	0.0 to 10.0	0.1 s	0.1 s	×	A	A	A	A	A	
	L6-04	Torque detection selection 2	0 to 8	1	0	×	A	A	A	A	A	
	L6-05	Torque detection level 2	0 to 300	1%	150%	×	A	A	A	A	A	
	L6-06	Torque detection time 2	0.0 to 10.0	0.1 s	0.1 s	×	A	A	A	A	A	
Torque Limits	L7-01	Forward drive torque limit	0 to 300	1%	200%	×	×	×	A	A	A	49
	L7-02	Reverse drive torque limit	0 to 300	1%	200%	×	×	×	A	A	A	
	L7-03	Forward regenerative torque limit	0 to 300	1%	200%	×	×	×	A	A	A	
	L7-04	Reverse regenerative torque limit	0 to 300	1%	200%	×	×	×	A	A	A	
	L7-06	Integral time setting for torque limit	5 to 10000	1 ms	200 ms	×	×	×	A	×	×	
	L7-07	Control method selection for torque limit during accel/decel	0, 1	1	0	×	×	×	A	×	×	
Hardware Protection	L8-01	Protect selection for internal DB resistor (Type ERF)	0, 1	1	0	×	A	A	A	A	A	—
	L8-02	Overheat pre-alarm level	50 to 130	1°C	95°C*2	×	A	A	A	A	A	
	L8-03	Operation selection after overheat pre-alarm	0 to 3	1	3	×	A	A	A	A	A	
	L8-05	Input open-phase protection selection	0, 1	1	0	×	A	A	A	A	A	
	L8-07	Output open-phase protection selection	0 to 2	1	0	×	A	A	A	A	A	
	L8-09	Ground protection selection	0, 1	1	1	×	A	A	A	A	A	
	L8-10	Cooling fan control selection	0, 1	1	0	×	A	A	A	A	A	
	L8-11	Cooling fan control delay time	0 to 300	1 s	60 s	×	A	A	A	A	A	
	L8-12	Ambient temperature	45 to 60°C	1°C	45°C	×	A	A	A	A	A	
	L8-15	OL2 characteristics selection at low speeds	0, 1	1	1	×	A	A	A	A	A	
	L8-18	Software CLA selection	0, 1	1	1	×	A	A	A	A	A	
	L8-32	OH1 detection of Inverter's cooling fan	0, 1	1	1	×	A	A	A	A	A	
	L8-38#	Carrier frequency reduction selection	0, 1	1	1	×	A	A	A	×	×	
	L8-39#	Reduced carrier frequency	0.4 to 30	0.1 kHz	2.0 kHz	×	A	A	A	×	×	
L8-41#	Current alarm	0, 1	1	1	×	A	A	A	A	A		
Hunting Prevention Function	N1-01	Hunting-prevention function selection	0, 1	1	1	×	A	A	×	×	×	—
	N1-02	Hunting-prevention gain	0.00 to 2.50	0.01	1.00	×	A	A	×	×	×	
	N1-03	Hunting-prevention time constant	0 to 500	1 ms	10 ms*2	×	A	A	×	×	×	
Speed Feedback Protection Control Functions	N2-01	Speed feedback detection control (AFR) gain	0.00 to 10.00	0.01	1.00	×	×	×	A	×	×	—
	N2-02	Speed feedback detection control (AFR) time constant	0 to 2000	1 ms	50 ms	×	×	×	A	×	×	
	N2-03	Speed feedback detection control (AFR) time constant 2	0 to 2000	1 ms	750 ms	×	×	×	A	×	×	
High-slip Braking	N3-01	High-slip braking deceleration frequency width	1 to 20	1%	5%	×	A	A	×	×	×	—
	N3-02	High-slip braking current limit	100 to 200	1%	150%	×	A	A	×	×	×	
	N3-03	High-slip braking stop dwell time	0.0 to 10.0	1.0 s	1.0 s	×	A	A	×	×	×	
	N3-04	High-slip braking OL time	30 to 1200	1 s	40 s	×	A	A	×	×	×	

#: The constants are available only for version PRG: 1039 or later.

The settings and control modes marked with # are also available for version PRG: 1039 or later.

*1: The setting range is 0 to 2 for flux vector control and open-loop vector control 2.

*2: The factory setting depends on the capacity of the Inverter (o2-04). The value for a 200 V class Inverter of 0.4 kW is given.

Function	No.	Name	Setting Range	Minimum Setting Unit	Factory Setting	Online Changing	Control Mode					Ref. Page	
							V/f without PG	V/f with PG	Open Loop Vector1	Flux Vector	Open Loop Vector2		
Speed Estimation	N4-07	Integral time of speed estimator	0.000 to 9.999	0.001 ms	0.030 ms	×	×	×	×	×	A	—	
	N4-08	Proportional gain of speed estimator	0 to 100	1	15	×	×	×	×	×	A		
	N4-10	High-speed proportional gain of speed estimator	0 to 1000.0	0.1	15.0	×	×	×	×	×	A		
	N4-11	Speed estimator switching frequency	40 to 70	1 Hz	70 Hz	×	×	×	×	×	A		
	N4-15	Low-speed regeneration stability coefficient 1	0.0 to 3.0	0.1	0.3	×	×	×	×	×	A		
	N4-17	Torque adjustment gain	0.0 to 5.0	0.1	0.8	×	×	×	×	×	A		
	N4-18	Feeder resistance adjustment gain	0.90 to 1.30	0.01	1.00	×	×	×	×	×	A		
	N4-28	Speed estimator switching frequency 2	20 to 70	1 Hz	50 Hz	×	×	×	×	×	A		
	N4-29	Torque adjustment gain 2	0.00 to 0.40	0.01	0.10	×	×	×	×	×	A		
	N4-30	Low-speed regeneration stability coefficient	0.00 to 10.00	0.01	1.00	×	×	×	×	×	A		
	N4-32	Speed estimator gain fluctuation frequency 1	0.0 to 60.0	0.1 Hz	5.0 Hz	×	×	×	×	×	A		
	N4-33	Speed estimator gain fluctuation frequency 2	0.0 to 60.0	0.1 Hz	20.0 Hz	×	×	×	×	×	A		
N4-34	Speed estimator gain fluctuation rate	0.0 to 200.0	0.1%	200.0%	×	×	×	×	×	A			
Feed Forward	N5-01	Feed forward control selection	0, 1	1	0*1	×	×	×	×	A	A	—	
	N5-02	Motor acceleration time	0.001 to 10.000	0.001 s	0.178 s*2	×	×	×	×	A	A		
	N5-03	Feed forward proportional gain	0.0 to 100.0	0.1	1.0	×	×	×	×	A	A		
Monitor Select	o1-01	Monitor selection	4 to 50	1	6	○	A	A	A	A	A	—	
	o1-02	Monitor selection after power up	1 to 4	1	1	○	A	A	A	A	A		
	o1-03	Frequency units of reference setting and monitor	0 to 39999	1	0	×	A	A	A	A	A		35
	o1-04	Setting unit for frequency constants related to V/f characteristics	0, 1	1	0	×	×	×	×	A	A		—
	o1-05	LCD brightness adjustment	0 to 5	1	3	○	A	A	A	A	A		—
Multi-function Selections	o2-01	LOCAL/REMOTE key enable/disable	0, 1	1	1	×	A	A	A	A	A	35	
	o2-02	STOP key during control circuit terminal operation	0, 1	1	1	×	A	A	A	A	A		
	o2-03	User constant initial value	0 to 2	1	0	×	A	A	A	A	A	31	
	o2-04	kVA selection	0 to FF	1	0*2	×	A	A	A	A	A		
	o2-05	Frequency reference setting method selection	0, 1	1	0	×	A	A	A	A	A		
	o2-06	Operation selection when digital operator is disconnected	0, 1	1	0	×	A	A	A	A	A		
	o2-07	Cumulative operation time setting	0 to 65535	1 hour	0 hour	×	A	A	A	A	A	—	
	o2-08	Cumulative operation time selection	0, 1	1	0	×	A	A	A	A	A		
	o2-10	Fan operation time setting	0 to 65535	1 hour	0 hour	×	A	A	A	A	A		
	o2-12	Fault trace/fault history clear function	0, 1	1	0	×	A	A	A	A	A		
	o2-14	Output power monitor clear selection	0, 1	1	0	×	A	A	A	A	A		
o2-18#	Capacitor maintenance setting	0 to 150	1%	0%	×	A	A	A	A	A			
Copy Function	o3-01	Copy function selection	0 to 3	1	0	×	A	A	A	A	A	55	
	o3-02	Read permitted selection	0, 1	1	0	×	A	A	A	A	A		
Motor Autotuning	T1-00	Motor 1/2 selection*3	1, 2	1	1	×	A	A	A	A	A	—	
	T1-01	Autotuning mode selection	0 to 3*4*5, 4#	1	0*5	×	A	A	A	A	A		
	T1-02	Motor output power*6	0.00 to 650.00*8	0.1 kW	0.40 kW*2	×	A	A	A	A	A		
	T1-03	Motor rated voltage*6*7	0 to 255.0 V*9	0.1 V	200.0 V*9	×	×	×	A	A	A		
	T1-04	Motor rated current*6	0.32 to 6.40 A*8	0.01 A	1.90 A*2	×	A	A	A	A	A		
	T1-05	Motor base frequency*5*6*7	0 to 400.0*9	0.1 Hz	60.0 Hz	×	×	×	A	A	A		
	T1-06	Number of motor poles	2 to 48	1 pole	4 pole	×	×	×	A	A	A		
	T1-07	Motor base speed*6	0 to 24000*9	1 min ⁻¹	1750 min ⁻¹	×	×	×	A	A	A		
	T1-08	Number of PG pulses when tuning	0 to 60000	1	600	×	×	×	×	○	×		
	T1-09#	Motor no-load current*10	0.00 to 1.89*2	0.01 A	1.20 A*2	×	×	×	A	A	A		

#: The constants are available only for version PRG: 1039 or later. The settings and control modes marked with # are also available for version PRG: 1039 or later.

*1: The factory setting will change when the control method (A1-02) is changed. (Flux vector factory settings are given.)

*2: The factory setting depends on the capacity of the Inverter (o2-04). The value for a 200 V class Inverter of 0.4 kW is given.

*3: Not normally displayed. Displayed only when a motor switch command is set for a multi-function digital input (one of H1-01 to H1-10 set to 16).

*4: Set T1-02 and T1-04 when 2 is set for T1-01.

*5: Only set value 2 (Stationary autotuning for line-to-line resistance only) is possible for V/F control or V/F control with PG. However, the setting is 2 or 3 for PRG: 1033 or later.

*6: For fixed output motors, set the base speed value.

*7: For Inverter motors or for specialized vector motors, the voltage or frequency may be lower than for general-purpose motors. Always confirm the information on the nameplate or in test reports. If the no-load values are known, input the no-load voltage in T1-03 and the no-load current in T1-05 to ensure accuracy.

*8: The settings that will ensure stable vector control are between 50% and 100% of the Inverter rating.

*9: The setting range is 10% to 200% of the Inverter's rated output current.

*10: Displayed only when Stationary autotuning 2 is selected (T1-01= 4).

Note: Version PRG: Stationary Autotuning is available after 1039.

To use vector control for elevator or conveyor applications, set the tuning mode to Stationary Autotuning 2 (T1-01 = 4).

Constant Descriptions

The Varispeed G7 provides various functions to upgrade machine functions and performances. Refer to each sample.

Objective	Function Settings	Used Constants	Ref. Page	
1. Items to be Confirmed before Operation	Set Environment of Inverter	A1-00, A1-01	31	
	Initialize Constants	A1-03, o2-03		
	Set, Reset Password	A1-04, A1-05		
	Select Control Method	A1-02		
	Set Input Voltage	E1-01		
	Set Motor Rated Current		E2-01	32
		Set V/f (Fixed V/f Pattern)	E1-03	33
	Set V/f (Optional V/f Pattern)		E1-04 to 13	34
		Set Accel/Decel Time	C1-01 to 08	
	Select Operation Method	Select Operation Method	b1-01, b1-02	35
Select Operator Key Functions		o2-01, o2-02		
Set Frequency Reference/Monitor Setting Unit Freely		o1-03		
2. Set Operation Conditions	Limit the Direction of Rotation	b1-04	36	
	Run at Low Speed	d1-17, H1-01 to 10		
	Multi-Step Speed Selection	A1-01, b1-01, b1-02, d1-01 to 17		
	Use Four Types of Accel/Decel Time		C1-01 to 08, C1-10, H1-01 to 10	37
		Soft Start	C2-01 to 04	
	Limit the Speed	Operation to Avoid Resonance	d2-01 to 03	38
		Operation to Avoid Resonance	d3-01 to 04	
		Frequency Reference by Pulse Train Input	b1-01, H6-01, H6-02	
	Adjust the Speed Setting Signal		H3-01 to 11	39
		Automatic Restart after Momentary Power Loss	L2-01, L2-02	
	Continue Operation at Constant Speed when Frequency Reference Missing		L4-05	40
		Operate Coasting Motor without Trip	b2-01 to 03, H1-01 to 10	
	Continue Operation by Automatic Fault Reset		L5-01, L5-02	41
		Temporary Hold of Accel/Decel	H1-01 to 10, d4-01	
	Torque Detection		L6-01 to 06	42
		Frequency Detection	H2-01 to 03, L4-01 to 04	
	Reduce Motor Noise or Leakage Current		C6-02	44
		Use Frequency Meter or Ammeter	H4-01, H4-04, H4-07, H4-08	
	Calibrate Indications of Frequency Meter or Ammeter		H4-02, H4-03, H4-05, H4-06	45
Use Pulse Monitor		H6-06, H6-07		
3. Select Stopping Method	Select Stopping Method	b1-03	46	
4. Build Interface Circuits with External Devices	Use Input Signals	H1-01 to 10	47	
	Use Output Signals	H2-01 to 05	48	
5. Adjust Motor Torque	Compensate for Torque at Start/Low-speed Operation	C4-01	49	
	Limit Motor Torque	L7-01 to 04		
	Prevent Motor from Stalling	L3-01 to 06	50	
6. Reduce Motor Speed Fluctuation	Control Motor Slip	C3-01, C5-01 to 04	51	
7. Motor Protection	Motor Overload Detection	E2-01, L1-01, L1-02	52	
8. PID Control	—	b1-01, b5-01 to 10, H3-08	53	
9. Control by MEMOBUS Communications	—	b1-01, b1-02, H5-01 to 07, U1-39	54	
10. Energy-saving Control	Use Energy-saving Mode	b8-01, b8-04	55	
11. Use Constant Copy Function	Copy or Compare Constants	o3-01, o3-02		

1. Items to be Confirmed before Operation

Set Environment of Inverter

Language selection for digital operator display A1-00
Constant access level A1-01

The factory settings are: A1-00 = 1 and A1-01 = 2. Change the settings according to your application.

- (1) Digital operator language display
A1-00 = 0 : English, 1 : Japanese, 2 : German,
3 : French, 4 : Italian, 5 : Spanish, 6 : Portuguese

- (2) Constant access level
This Inverter classifies the constants reference level according to the significance, as follows.

0 : For monitoring only (Possible to read in drive mode, set/read A1-01 and A1-04)

1 : User selected constants only
(Possible to set/read only the constants that are set to A2-01 to 32)

2 : ADVANCED
(Possible to set/read the constants that can be changed in the advanced program mode and quick program mode)

Note: To switch to the quick program mode, press the  key and then press the  key while QUICK is displayed.

Initialize Constants

Initialize A1-03
User constant initial value o2-03

Initializing indicates that the set value is returned to the factory setting.

When replacing the control board, or when returning the constants to the initial setting for test operation, set A1-03 to the following value to initialize the constant.

- Initialize to user-defined constants using o2-03 : 1110
- Initialize to factory-set constants (2-wire sequence) : 2220
- Initialize to factory-set constants (3-wire sequence) : 3330

Constant o2-03 stores or clears the initial value used for the user constant initialization. By using this constant, the user-set constants can be stored in the Inverter as the user initial values.

Setting Value	Description
0	Memory held/not set
1	Starts memory. (Stores the constants that have been set when o2-03 was set to 1, as user-set initial values.)
2	Clears memory. (Clears stored user-set initial values.)

Select Control Method

Control method selection A1-02

This Inverter selects the control methods according to the machines applied. V/f control is suitable for the fluid machines such as fans, blowers or pumps while open loop vector control is suitable for machines that require high torque at low speed such as feeding machines.

The factory setting is: A1-02 = 2 (Open loop vector control 1).

- 0 : V/f control without PG
1 : V/f control with PG (Either of the following PG control cards is required.)
2 : Open loop current vector control 1
3 : Closed loop current vector control (The PG-B2 or PG-X2 PG control card given below is required.)
4 : Open loop current vector control 2
(Do not use this setting for elevator applications.)

[Specifications of PG control cards]

PG-A2 : For single-pulse open collector type PG
PG-B2 : For 2-phase (A, B) type, complementary type PG

PG-D2 : For single pulse, RS-422 (line driver) PG

PG-X2 : For 2-phase (A, B) type or RS-422 (line driver) PG with origin point (A, B, Z)



Set, Reset Password

Password A1-04
Password setting A1-05

When a password is set to A1-05, any constants of A1-01 to 03 and A2-01 to 32 cannot be read or changed unless the set values of A1-04 and A1-05 coincide with each other.

By using the password function and the constant access level 0 [Monitoring Only] together, you can prohibit setting and reading of all the constants except A1-00 so that your know-how can be secured.

A1-05 is not displayed by normal operation.

Pressing the  key and  key simultaneously displays A1-04.

Set Input Voltage

Input voltage setting E1-01

Set the Inverter input voltage value.

This value will be the reference value for the protective functions.

200 V class : setting range 155 to 255 V (initial value: 200 V)
400 V class : setting range 310 to 510 V (initial value: 400 V)

Set Motor Rated Current

Motor rated current E2-01

Set the rated current value on the motor nameplate.

This value will be the reference value for the motor protection by electronic thermal overload relay or torque limit.

The following tables show the standard set values of each motor output.

If the rated current value of the applicable motor differs from the value in the following table, change the set value.

Note: If the motor rated current value is larger than the Inverter rated output current, change the Inverter so that the Inverter rated output current will exceed the motor rated current.

200 V Class

Inverter Model CIMR-G7A	20P4	20P7	21P5	22P2	23P7	25P5	27P5	2011	2015
Maximum Applicable Motor Output kW	0.4	0.75	1.5	2.2	3.7	5.5	7.5	11	15
Inverter Rated Output Current A	3.2	6.0	8.0	12.0	18.0	27.0	34.0	49.0	66.0
Motor Current A (Factory Setting)	1.9	3.3	6.2	8.5	14.0	19.6	26.6	39.7	53.0

Inverter Model CIMR-G7A	2018	2022	2030	2037	2045	2055	2075	2090	2110
Maximum Applicable Motor Output kW	18.5	22	30	37	45	55	75	90	110
Inverter Rated Output Current A	80.0	96.0	130.0	160.0	183.0	224.0	300.0	358.0	415.0
Motor Current A (Factory Setting)	65.8	77.2	105.0	131.0	160.0	190.0	260.0	260.0	260.0

400 V Class

Inverter Model CIMR-G7A	40P4	40P7	41P5	42P2	43P7	45P5	47P5	4011	4015	4018	4022	4030
Maximum Applicable Motor Output kW	0.4	0.75	1.5	2.2	3.7	5.5	7.5	11	15	18.5	22	30
Inverter Rated Output Current A	1.8	3.4	4.8	6.2	9.0	15.0	21.0	27.0	34.0	42.0	52.0	65.0
Motor Current A (Factory Setting)	1.0	1.6	3.1	4.2	7.0	9.8	13.3	19.9	26.5	32.9	38.6	52.3

Inverter Model CIMR-G7A	4037	4045	4055	4075	4090	4110	4132	4160	4185	4220	4300
Maximum Applicable Motor Output kW	37	45	55	75	90	110	132	160	185	220	300
Inverter Rated Output Current A	80.0	97.0	128.0	165.0	195.0	240.0	255.0	302.0	370.0	450.0	605.0
Motor Current A (Factory Setting)	65.6	79.7	95.0	130.0	156.0	190.0	223.0	270.0	310.0	370.0	500.0

Set V/f (Fixed V/f Pattern)

V/f pattern selection E1-03

Set the V/f pattern by E1-03.
 The fixed V/f pattern in the following table can be selected by setting data 0 to E of E1-03.
 The data of E1-03 can be set at F to change the data to optional V/f pattern.
 Note: Factory setting: E1-03 = F

Fixed V/f Pattern (200 V class 2.2 to 45 kW V/f pattern) (The voltage doubles for 400 V class.)

Application	Specification	E1-03	V/f Pattern*1	Application	Specification	E1-03	V/f Pattern*1
Constant Torque Characteristics (general-purpose)	50 Hz	①		High Starting Torque*2	50 Hz	⑧	
	60 Hz	60 Hz saturation ① ②			High starting torque	⑨	
		50 Hz saturation ②			Medium starting torque	A	
	72 Hz	③			90 Hz	③	
Variable Torque Characteristics (wind/water force machines)	50 Hz	Variable torque 3 ④		Constant Output Operation (machine tools)	120 Hz	D	
		Variable torque 2 ⑤					
	60 Hz	Variable torque 3 ⑥					
Variable torque 2 ⑦							

*1: Consider the following items as the conditions for selecting a V/f pattern. They must be suitable for:

- (1) The motor voltage and frequency characteristics.
- (2) The maximum motor speed.

*2: Select high starting torque only in the following conditions. Normally, this selection is not required since sufficient starting torque is secured by full-automatic torque boost function.

- (1) The wiring distance is long (approx. 150 m or more).
- (2) The voltage drop at startup is large.
- (3) AC reactor is inserted in the input or output of the Inverter.
- (4) A motor smaller than the maximum applicable motor is used.

*3: The V/f characteristics (A)/(B) value is A: 1.5 kW or less, B: 55 kW or more.

Set V/f (Optional V/f Pattern)

Max. output frequency	E1-04
Max. voltage	E1-05
Max. voltage output frequency	E1-06
Mid. output frequency	E1-07
Mid. output frequency voltage	E1-08
Min. output frequency	E1-09
Min. output frequency voltage	E1-10
Mid. output frequency 2	E1-11
Mid. output frequency voltage 2	E1-12
Base voltage	E1-13

Set the following when using special motor (high-speed motor, etc.), or when the torque of the machine is especially required. The motor torque increases by increasing the V/f pattern voltage, but, too high voltage can cause the following failure.

- Excessive current flows into the motor to cause failure of the Inverter.
- The motor heats and vibrates excessively.

Increase the voltage gradually, while checking the motor current.

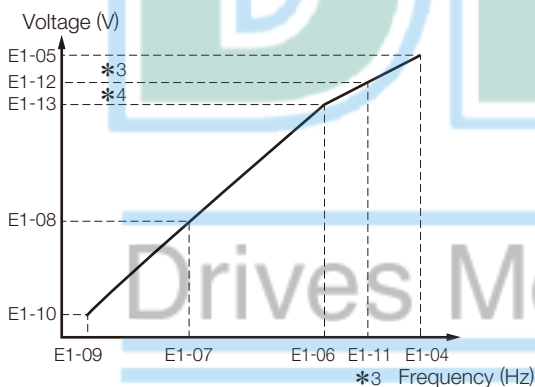

Set E1-04 to 11 so that $E1-04 \geq E1-11 \geq E1-06 \geq E1-07 \geq E1-09$.

To make the line of the V/f characteristics straight, set E1-07 and E1-09 to the same value. At this time, the set value of E1-08 is disregarded.

E1-11, 12 and 13 must be set only at V/f minute adjustment in the constant output area. Normally, they do not have to be set.

Constant No.	Name	Unit	Setting Range	Factory Setting
E1-04	Max. output frequency	0.1 Hz	40.0-400.0 Hz	60.0 Hz
E1-05	Max. voltage	0.1 V	0.0-255.0 V*1	200.0 V*1
E1-06	Max. voltage output frequency (Base frequency)	0.1 Hz	0.0-400.0 Hz	60.0 Hz
E1-07	Mid. output frequency	0.1 Hz	0.0-400.0 Hz	3.0 Hz*2
E1-08	Mid. output frequency voltage	0.1 V	0.0-255.0 V*1	15.0 V*1*2
E1-09	Min. output frequency	0.1 Hz	0.0-400.0 Hz	1.5 Hz*2
E1-10	Min. output frequency voltage	0.1 V	0.0-255.0 V*1	9.0 V*1*2
E1-11	Mid. output frequency 2*3	0.1 Hz	0.0-400.0 Hz	0.0 Hz*3
E1-12	Mid. output frequency voltage 2*3	0.1 V	0.0-255.0 V*1	0.0 V*3
E1-13	Base voltage*4	0.1 V	0.0-255.0 V*1	0.0 V*4

*1: The value doubles for 400 V class.

*2: The factory setting differs according to the control method. The setting of this table is for V/f control without PG.

*3: When "0.0" is set, the setting in E1-11, -12 is disregarded.

*4: When "0.0" is set, E1-13 = E1-05.

Set Accel/Decel Time

Acceleration time 1, 2, 3, 4

C1-01, C1-03, C1-05, C1-07

Deceleration time 1, 2, 3, 4

C1-02, C1-04, C1-06, C1-08

Set the time from when the motor stops to when the motor accelerates up to the maximum output frequency (E1-04), and the time from when the motor runs at the maximum output frequency to when it stops (or deceleration time).

Note: Factory setting: Acceleration time C1-01 = 10.0 s
Deceleration time C1-02 = 10.0 s

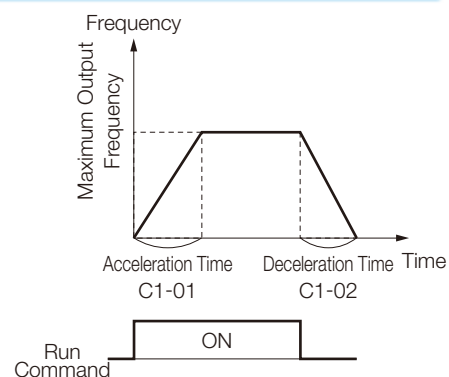

Select Operation Method

Master frequency reference selection **b1-01**
 Operation method selection **b1-02**

Select whether operation is to be performed by the digital operator, by the control circuit terminal or by communications, using master frequency reference b1-01 and operation method b1-02.

Factory setting is: b1-01 = 1, b1-02 = 1.

Set Value	Master Frequency Reference b1-01
0	Digital operator
1	Control circuit terminal (analog input)
2	MEMOBUS communications
3	Option card
4	Pulse train input

Set Value	Operation Method b1-02
0	Digital operator
1	Control circuit terminal (sequence input)
2	MEMOBUS communications
3	Option card

- (1) By setting b1-01 to 0, frequency reference can be input from the digital operator.
- (2) By setting b1-01 to 1, frequency reference can be input from control circuit terminal A1 (voltage input) or control circuit terminal A2 (voltage/current input).
 Note: To input a current signal (4 to 20 mA) to terminal A2, turn ON "2" of dip switch S1 (factory setting: ON). Then set H3-08 to 2 (factory setting: 2). To input a voltage signal (0 to 10 V) to terminal A2, turn OFF "2" of dip switch S1. Finally, set H3-08 to 0 or 1.
- (3) By setting b1-01 to 2, frequency reference can be input from the master controller at MEMOBUS communications.
- (4) By setting b1-01 to 4, the pulse train input which is input to control circuit terminal RP becomes the frequency reference.

Select Operator Key (LOCAL/REMOTE, STOP) Functions

LOCAL/REMOTE key selection **o2-01**
 STOP key selection **o2-02**

- o2-01 = 0 : LOCAL/REMOTE changeover disabled
 1 : LOCAL/REMOTE changeover enabled
- o2-02 = 0 : Operator STOP key disabled during control circuit terminal operation (b1-02=1)
 1 : Operator STOP key always enabled during control circuit terminal operation (b1-02=1)

Set Frequency Reference/Monitor Setting Unit Freely

Frequency units of reference setting and monitor **o1-03**

Frequency can be set in the unit suitable for rotation speed, flow rate or line speed of the actual machines.

Operator Display Mode

o1-03	Frequency Setting Mode	
	d1-□□	Display Mode at Power ON
0	d1-01 to 17: Set in the units of 0.01 Hz	
1	d1-01 to 17: Set in the units of 0.01% (maximum output frequency: 100%)	
2 to 39	Set in the units of min ⁻¹ . min ⁻¹ = 120 × frequency reference (Hz) / o1-03 (o1-03 sets the number of motor poles.)	
40 to 39999	Set the number of displayed digits below the decimal point with the value in the fifth digit of o1-03. 5th digit value = 0 : Displayed as ×××× 5th digit value = 1 : Displayed as ×××. × 5th digit value = 2 : Displayed as ××. ×× 5th digit value = 3 : Displayed as ×. ××× The set value of 100% frequency is specified with the first to fourth digits of o1-03. (Example) 1 Set o1-03 to 12000 when the set value of 100% speed is 200.0. 2 Set o1-03 to 26500 when the set value of 100% speed is 65.00.	

o1-03	Frequency Monitor Mode	
	d1-□□, U1-□□	Display Mode at Power ON
0	d1-01 to 17 : Displayed in the units of 0.01 Hz.	
1	d1-01 to 17 : Displayed in the units of 0.01%.	
2 to 39	Set in the units of min ⁻¹ . min ⁻¹ = 120 × frequency reference (Hz) / o1-03 (o1-03 sets the number of motor poles.)	
40 to 39999	Displayed with numerical value and accuracy specified by the set value of o1-03. (Example) 1 100% speed and 60% speed are displayed as 200.0 and 120.0, respectively when o1-03 is set to 12000. 2 60% speed is displayed as 39.00 when o1-03 is set to 26500.	

2. Set Operation Conditions

Limit the Direction of Rotation

Prohibition of reverse operation b1-04

When reverse run disabled is set, reverse run command from the control circuit terminal or digital operator cannot be enabled. Use this setting for applications where reverse run will not be used (fans, pumps, etc.).

b1-04 Setting Value	Description
0	Reverse run enabled
1	Reverse run disabled

Note: When an Inverter forward run command is given, the motor output shaft rotates in the counterclockwise (CCW) direction viewed from the motor at the load side (output shaft side).

Run at Low Speed

Jog frequency reference d1-17 Multi-function input H1-01 to 10

Set Jog frequency in Multi-function contact input terminals S3 to S12. Next, input the Jog frequency reference and the forward (reverse) run command. Jogging can be performed with the jogging frequency set in d1-17. When multi-speed reference 1 to 4 is set along with Jog reference, the Jog reference has priority.

Name	Constant No.	Setting Value
Jog reference	d1-17	(Factory setting: 6.0 Hz)
Multi-function input (terminals S3 to S12)	H1-01 to H1-10	Set 6 in one of the terminals (JOG frequency selection).

The same operation can be also accomplished by the digital operator.

Press the key, and check that the remote LED (SEQ. REF) is OFF. When the remote LED (SEQ. REF) is

ON, press the key again to turn the light OFF.

Press the key on the digital operator for jogging, and release the key to stop the jogging.

Multi-Step Speed Selection

Master frequency reference selection	b1-01
Operation method selection	b1-02
Constant access level	A1-01
Frequency reference	d1-01 to 16
Jog frequency reference	d1-17
Multi-function input	H1-02 to 10
Terminal A2 function selection	H3-09
Terminal A3 function selection	H3-05

By combining 16-step frequency references, one jog frequency reference and multi-function terminal function selection, up to 17 steps of speed variations can be set step by step. (The following shows an example of 9-step speed.)

Operation method selection b1-01=0, b1-02=1

Constant access level A1-01=2

The range where multi-step speed frequency reference can be set or read depends on the program mode as follows:

QUICK : Up to 5 steps of speed variations can be set or read.
d1-01, 02, 03, 04, 17

ADVANCED: Up to 17 steps of speed variations can be set or read.
d1-01 to 17

Multi-function input terminals	S5 (function selection)	H1-03
	S6	H1-04
	S9	H1-07
	S10	H1-08
	S7	H1-05

Frequency reference	1 to 16	d1-01 to 16
Jog frequency reference		d1-17

An Example of 9-step Speed

Terminal	Constant No.	Factory Setting	Name
S5	H1-03	3	Multi-step speed reference 1
S6	H1-04	4	Multi-step speed reference 2
S9	H1-07	5	Multi-step speed reference 3
S7	H1-05	6	Jog reference selection

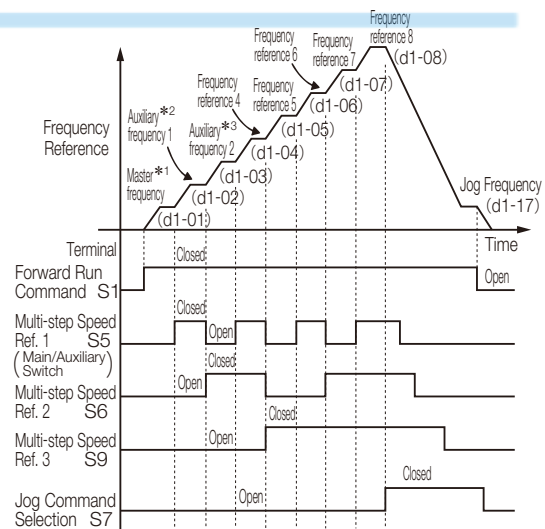

*1: When the preset reference 1 is b1-01 = 0, constant setting value (d1-01) is applied; when b1-01 = 1, the analog command set by control circuit terminal A1 is applied.

*2: When the preset reference 2 is H3-05 = 2, the analog frequency reference input through terminal A3 is applied; when the setting is H3-05=1F, constant setting value (d1-02) is applied.

*3: When the preset reference 3 is H3-09 = 3, the analog frequency reference input through terminal A2 is applied; when the setting is H3-09=0, constant setting value (d1-03) is applied.

Use Four (4) Types of Accel/Decel Time

Acceleration time 1 to 4 C1-01, C1-03, C1-05, C1-07
 Deceleration time 1 to 4 C1-02, C1-04, C1-06, C1-08
 Accel/decel time setting unit C1-10
 Multi-function input H1-01 to 05

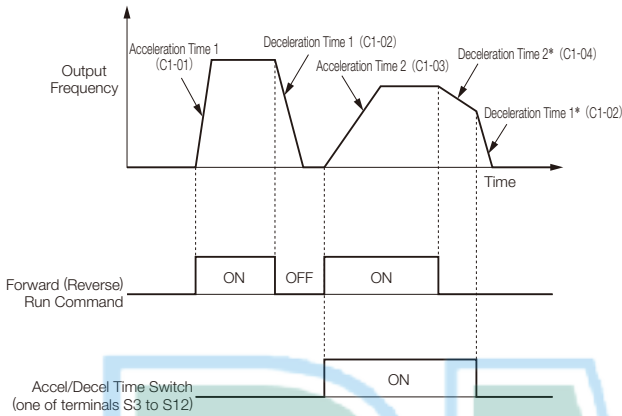

* When stopping method is deceleration to stop (b1-03=0).

Set "07" or "1A" (accel/decel time switch 1 or 2) in multi-function input (H1-01 to 10), to allow selection of 4 sets of accel/decel times by the ON/OFF of the accel/decel time switch (one of terminals S3 to S12).

Accel/decel Time Selection 1 Multi-function Input Setting = 07	Accel/decel Time Selection 2 Multi-function Input Setting = 1A	Accel Time	Decel Time
Open or not set	Open or not set	C1-01	C1-02
Closed	Open or not set	C1-03	C1-04
Open or not set	Closed	C1-05	C1-06
Closed	Closed	C1-07	C1-08

Constant No.	Name	Unit*	Setting* Range	Factory Setting
C1-01	Accel time 1	0.1 s (1 s for 1000 s or more)	0.0 to 6000.0 s	10.0 s
C1-02	Decel time 1	0.1 s (1 s for 1000 s or more)	0.0 to 6000.0 s	10.0 s
C1-03	Accel time 2	0.1 s (1 s for 1000 s or more)	0.0 to 6000.0 s	10.0 s
C1-04	Decel time 2	0.1 s (1 s for 1000 s or more)	0.0 to 6000.0 s	10.0 s
C1-05	Accel time 3	0.1 s (1 s for 1000 s or more)	0.0 to 6000.0 s	10.0 s
C1-06	Decel time 3	0.1 s (1 s for 1000 s or more)	0.0 to 6000.0 s	10.0 s
C1-07	Accel time 4	0.1 s (1 s for 1000 s or more)	0.0 to 6000.0 s	10.0 s
C1-08	Decel time 4	0.1 s (1 s for 1000 s or more)	0.0 to 6000.0 s	10.0 s

* C1-10 = 0 : Units of 0.01 sec. (Max. 600.00 seconds)
 C1-10 = 1 : Units of 0.1 sec. (Max. 6000.00 seconds)

Soft Start

S-curve characteristic time C2-01 to 04

Accel/decel by S-curve pattern can be accomplished to prevent shock at start, or stop of the machine.

Constant No.	Function	Setting Range	Factory Setting
C2-01	S-curve characteristic time at acceleration start	0.00 to 2.50 s	0.20 s
C2-02	S-curve characteristic time at acceleration start	0.00 to 2.50 s	0.20 s
C2-03	S-curve characteristic time at deceleration start	0.00 to 2.50 s	0.20 s
C2-04	S-curve characteristic time at deceleration start	0.00 to 2.50 s	0.00 s

Note: S-curve characteristic time is the time required for the 0 accel/decel rate to reach the formal accel/decel rate determined by the preset accel/decel time.

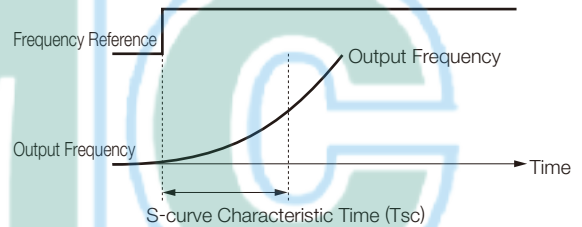

Setting the S-curve characteristic time, the acceleration or deceleration time will be longer by 1/2 of the S-curve characteristic time at start or end.

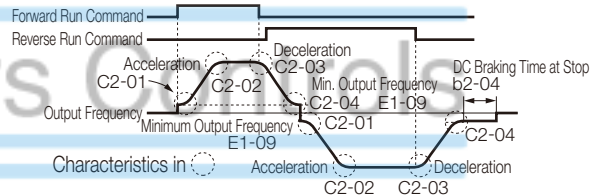

Time Chart when Switching Forward Run and Reverse Run at Deceleration to Stop (V/f control mode example)

Limit the Speed

Frequency reference upper limit	d2-01
Frequency reference lower limit	d2-02
Master speed reference lower limit	d2-03

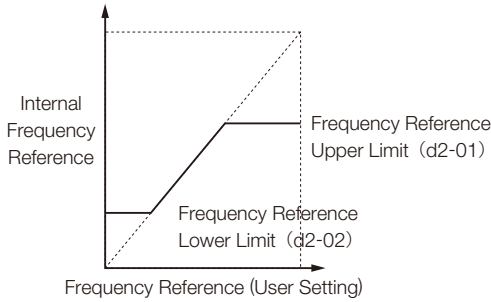

- (1) Limiting maximum frequency

Use d2-01 when the motor is to be rotated at certain min^{-1} or less.

Set the frequency reference upper limit value (d2-01) in the units of 0.1%.

(E1-04 maximum output frequency is 100%.)

Note: Factory setting: d2-01 = 100%
- (2) Limiting minimum frequency

Use d2-02 or d2-03 when the motor is to be rotated at certain min^{-1} or more.

There are two methods to limit the minimum frequency as follows:

 - Adjust the lower limit levels of all frequencies (d2-02)
 - Adjust the lower limit level of the master speed frequency (d2-03)

(The lower limit levels of the jog frequency, multistep speed frequencies or auxiliary frequency are not adjusted.)

Set the frequency reference lower limit (d2-02 or d2-03) in units of 0.1%. (E1-04 maximum output frequency is 100%.)

When running at frequency reference 0, operation continues at the lower limit value of the frequency reference. However, operation is not performed if the frequency lower limit value is set to less than the minimum output frequency (E1-09).

Note: Factory setting: d2-02 = 0.0%, d2-03 = 0.0%

Operation to Avoid Resonance

Jump frequency 1, 2, 3	d3-01 to 03
Jump frequency width	d3-04

The frequency that causes resonance can be jumped, to avoid resonance characteristics of the machine system. This function can also be applied to dead band control. Set 0.0 Hz to disable this function. Set jump frequencies 1 to 3 as follows.

$$d3-01 \geq d3-02 \geq d3-03$$

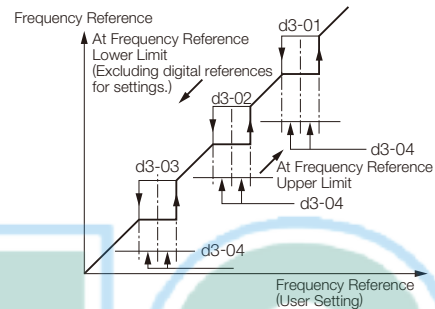

Note: Frequency varies smoothly without jumping during acceleration or deceleration.

Frequency Reference by Pulse Train Input

Reference selection	b1-01
Pulse train input function selection	H6-01
Pulse train input scaling	H6-02

By setting reference selection b1-01 to 4, frequency reference can be set by pulse train input from the control circuit terminal RP.

(1) Input pulse specifications

- Low level voltage 0.0 to 0.8 V
- High level voltage 3.5 to 13.2 V
- H duty 30 to 70%
- Pulse frequency 0 to 32 kHz

(2) How to give frequency reference

The value obtained by multiplying the maximum output frequency by the ratio of the set maximum value of input pulse frequency and the actual input pulse frequency makes reference frequency.

$$\text{Frequency reference} = \frac{\text{Input pulse frequency}}{\text{Pulse train maximum frequency (H6-02)}} \times \text{Maximum output frequency (E1-04)}$$

Constant No.	Name	Setting Value	Initial Value
b1-01	Reference selection	4	1
H6-01	Pulse train input function selection	0	0
H6-02	Pulse train input scaling	Pulse frequency to be 100% reference	1440 Hz

Adjusting the Speed Setting Signal

- Frequency reference input gain H3-02, H3-06, H3-10
- Frequency reference input bias H3-03, H3-07, H3-11
- Terminal A1 signal level selection H3-01
- Terminal A2 signal level selection H3-08
- Terminal A2 function selection H3-09
- Terminal A3 signal level selection H3-04
- Terminal A3 function selection H3-05

When the frequency reference is to be performed by analog input from control circuit terminals A1, A2, and A3 the relation between the analog input and frequency reference can be adjusted.

Terminal A1 and A3 are voltage input of 0 to +10 V. Terminal A2 can switch voltage or current input by setting H3-08.

The initial value of H3-08 is 2; a current input of 4 to 20 mA.

When terminal A2 is used as a voltage input of 0 to +10 V, set dip switch S1-2 on the control board to OFF (factory setting: ON), and set the signal level of H3-08 to 0.

Name	Description
Frequency reference level selection	Selects 0 to 10 V, 0 to ± 10 V or 4 to 20 mA input. 0 to ± 10 V input reverses with negative input.
Frequency % gain	Sets the ratio (%) against the Maximum frequency (E1-04) of the virtual output frequency when terminal input is 10 V (20 mA).
Reference ± % bias	Sets the ratio (%) against the Maximum frequency (E1-04) of the output frequency when terminal input is 0 V (4 mA).

Name	For Terminal A1	For Terminal A2	For Terminal A3	Setting Range	Factory Setting
Frequency reference level selection	H3-01	H3-08	H3-04	0: 0 to +10 V 1: -10 to +10 V 2: 4 to 20 mA	H3-01,04 =0 H3-08=2
Frequency % gain	H3-02	H3-10	H3-06	0.0 to 1000.0	100.0%
Reference ± % bias	H3-03	H3-11	H3-07	-100.0 to +100.0	0.0%

Note: 4 to 20 mA input is not accepted in terminal A1 and A3.

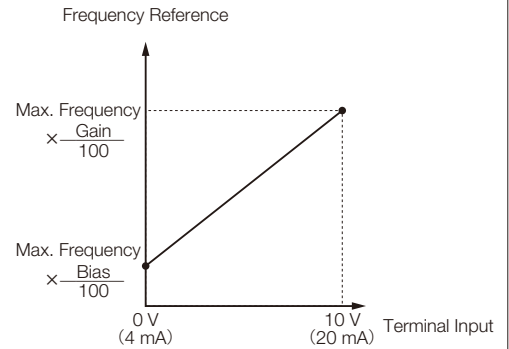

() is when current reference input is selected.

(1) 0 to 100% frequency reference operation by 0 to 5 V input (Example of terminal A1)

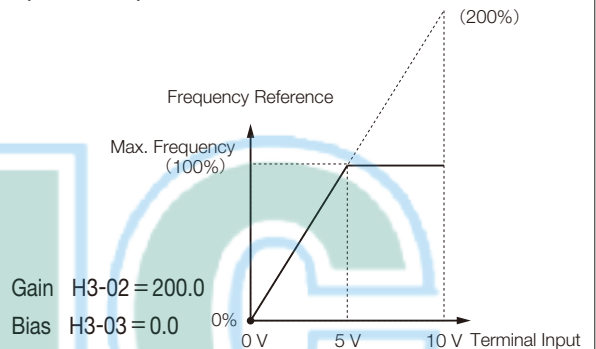

(2) 50 to 100% frequency reference operation by 0 to 10 V input (Example of terminal A1)

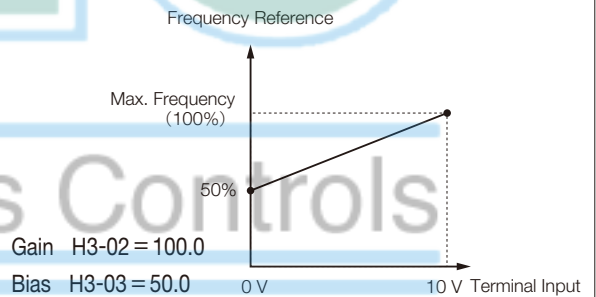

(3) 0 to 100% frequency reference operation by 1 to 5 V input (Example of terminal A1)

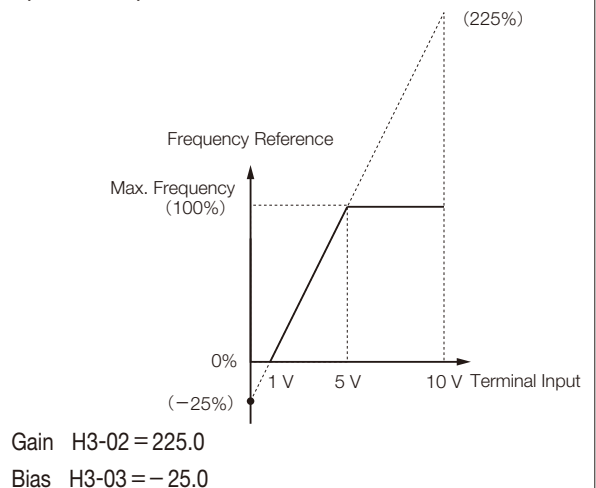

Automatic Restart after Momentary Power Loss

Momentary power loss detection L2-01
 Momentary power loss ridethru time L2-02

Momentary power loss detection
 Even if there is a momentary power loss, you can automatically restart the Inverter when power is restored and continue operating the motor.

L2-01 Setting	Description
0	Operation not continued (Factory setting)
1*1	Operation continued after power recovery within momentary power loss ridethru time (L2-02).
2*2	Operation continued after power recovery (no fault signal). (However, restarts only within the time established by the control power.)

*1: Hold the run command to continue the operation after recovery from momentary power loss.
 *2: When 2 is selected, the operation restarts if power supply voltage reaches its normal level. No fault signal is indicated.

Momentary power loss ridethru time
 Set the ridethru time to L2-02 when L2-01 is set to 1. The initial values depend on the Inverter capacities as follows.
 For 0.4 to 7.5 kW Inverters, a momentary power loss recovery unit (optional) can be added to ride through momentary power losses of up to 2.0 seconds.

Inverter Model	L2-02 Initial Value
CIMR-G7A	
20P4 to 27P5	0.1 to 1.0 s
2011 to 2110	2.0 s
40P4 to 47P5	0.1 to 1.0 s
4011 to 4300	2.0 s

Continue Operation at Constant Speed when Frequency Reference Missing

Operation when frequency reference is missing L4-05

Detection of missing frequency reference continues operation at 80% speed of the frequency reference before the frequency reference missed if the frequency reference by analog input is reduced by 90% or more in 400 ms.

Setting Value	Description
0	Stop (Operation following with the frequency reference.)
1	Operation continued at 80% speed of frequency reference before it missed

Operate Coasting Motor without Trip

Speed Search Reference "61", "62", "64"
 Multi-function input H1-01 to 10
 Zero speed level (DC injection braking start frequency) b2-01
 DC injection braking current b2-02
 DC injection braking time at start b2-03

Speed search reference or DC injection braking (at start) can be used to continue operation without tripping the motor during coasting.

- (1) Speed search reference
 This function is used to restart the motor during coasting without stopping the motor. This allows smooth switching of the motor from commercial power operation to Inverter operation. Set (search reference from max. output frequency) or (search command from preset frequency) in the multi-function input terminal (H1-01 to H1-10).
 Arrange the sequence so that the forward (reverse) run command is input at the same time or after the search reference.
 If the run command enters before the search reference, the search reference is disabled.

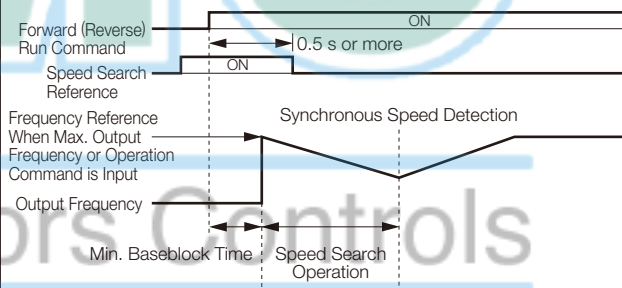

Time Chart at Search Reference Input

- (2) DC injection braking at start
 This function is used to restart the motor after applying DC injection braking current to the coasting motor.
 The time for direct current injection braking at start can be set unit of 0.1 sec in b2-03.
 The DC injection braking is set in b2-02. When setting of b2-03 is 0, direct current injection braking is not performed, and acceleration is performed from the minimum frequency.

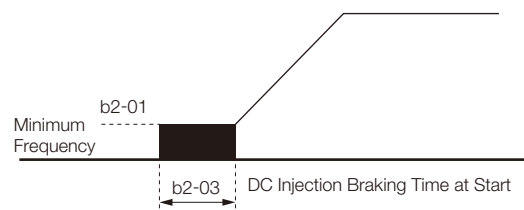

Continue Operation by Automatic Fault Reset (Fault Restart)

Number of auto restart attempts	L5-01
Auto restart operation selection	L5-02

If a failure occurs in the Inverter, the Inverter performs selfdiagnosis and automatically restarts operation. The self-diagnosis and restart count can be set in constant L5-01 (up to 10 times). Fault retry signal can be set to be output (L5-02 : 1) or no output (L5-02 : 0).

The following faults are dealt with by this function.

- OC (overcurrent)
- PUF (fuse blown)
- GF (ground fault)
- LF (output open-phase)
- OL1 (motor overload)
- OL3 (overtorque)
- OH1 (heatsink overheating)
- UV1* (main circuit undervoltage, main circuit MC malfunction)
- OV (DC main circuit overvoltage)
- RH (braking resistor overheat)
- RR (braking transistor failure)
- PF (main circuit voltage fault)
- OL2 (Inverter overload)
- OL4 (overtorque)

* Retry enabled when main circuit undervoltage (L2-01) is set to 1 or 2 (operation continues after power recovery).

The accumulated error retry count is cleared in the following cases.

- When no error occurred for 10 minutes after retry
- When error set signal is input after defining the error
- When power is turned OFF

If any fault other than the above faults occurs, a fault contact output operates to shut off the output and the motor coasts to a stop.

Note: Do not use this function for any lifting loads.

Temporary Hold of Accel/Decel

Accel/decel hold "OA"	
Multi-function input	H1-01 to 10
Frequency reference hold function selection	d4-01

When accel/decel hold command is input during accel/decel, accel/decel is held while the command is enabled, holding the existing output frequency. When the stop command is input, the accel/decel hold status is reset, and it enters the stop status.

Set (Accel/decel hold command) in the input terminal function (H1-01 to H1-10). By setting H1-01 to H1-10 [Multi-function input (terminals S3 to S12)] to A (accel/decel hold), acceleration or deceleration is stopped when the terminal turns ON and then the output frequency is held.

Acceleration or deceleration starts again when the terminal turns OFF.

Use d4-01 to specify whether the frequency reference during hold is to be stored.

d4-01 = 0 : Disabled (Restarts from zero.)

d4-01 = 1 : Enabled (Restarts at frequency that was held previous time.)

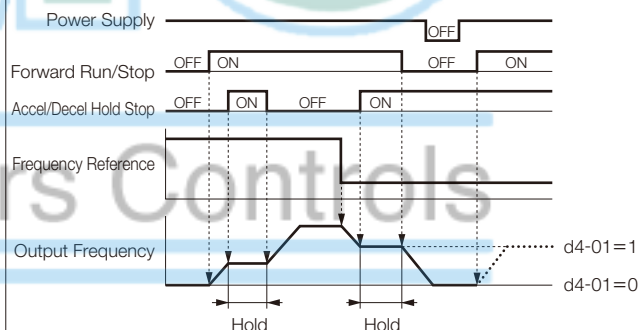

Time Chart when Accel/decel Hold Command Used

Torque Detection

Torque detection selection 1, 2	L6-01, L6-04
Torque detection level 1, 2	L6-02, L6-05
Torque detection time 1, 2	L6-03, L6-06

If an excessive load (overtorque) is applied to the machine or if the load quickly become lighter (undertorque), you can output an alarm signal to multi-function terminals (M1-M2, P1-PC, or P2-PC). The Varispeed G7 has two kinds of overtorque/undertorque detection.

Overtorque/undertorque detection signal is activated by setting torque detection selection 1 (NO contact: 0B, NC contact: 17) or torque detection selection 2 (NO contact: 18, NC contact: 19) in output terminal function selection H2-01, H2-02 or H2-03.

Torque detection level is the current level (Inverter rated output current 100%) at V/f control and the motor torque level (motor rated torque 100%) at vector control.

• Detection of overtorque

To detect overtorque, select 1, 2, 3 or 4 for the set value of L6-01 or L6-04. L6-02 or L6-05 becomes the overtorque detection level.

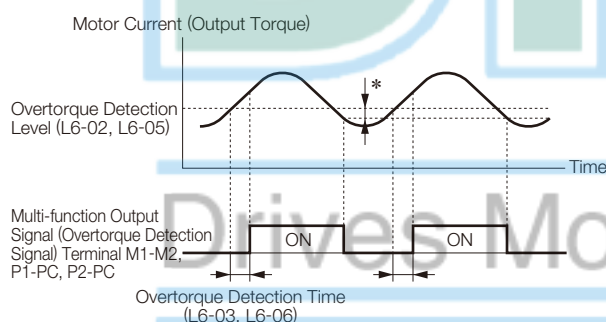

* The releasing width of overtorque detection is approx. 10% of the Inverter rated current (or motor rated torque).

• Detection of undertorque

To detect undertorque, select 5, 6, 7 or 8 for the set value of L6-01 or L6-04. L6-02 or L6-05 becomes the undertorque detection level.

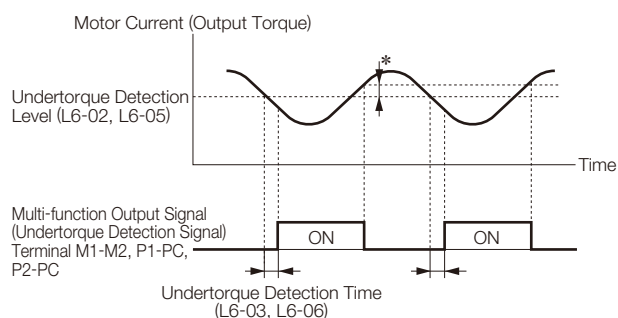

* The releasing width of undertorque detection is approx. 10% of the Inverter rated current (or motor rated torque).

Setting for Overtorque/Undertorque Detection Function

Constant No.	Function	Setting Range	Factory Setting
L6-01	Overtorque/undertorque detection selection 1	0 to 8	0
L6-02	Overtorque/undertorque detection level 1	0 to 300%	150%
L6-03	Overtorque/undertorque detection time 1	0.0 to 10.0 s	0.1 s
L6-04	Overtorque/undertorque detection selection 2	0 to 8	0
L6-05	Overtorque/undertorque detection level 2	0 to 300%	150%
L6-06	Overtorque/undertorque detection time 2	0.0 to 10.0 s	0.1 s

Setting Values of L6-01 and L6-04

The following table shows relations between setting values of L6-01 or L6-04 and alarms at overtorque/undertorque detection.

Setting Value	Function
0	Overtorque/undertorque detection disabled
1	Overtorque detection only during speed agree/operation continued after detection (warning)
2	Overtorque detection at any time during operation/operation continued after detection (warning)
3	Overtorque detection only during speed agree/output shut off at detection (protective operation)
4	Overtorque detection at any time during operation/output shut off at detection (protective operation)
5	Undertorque detection only during speed agree/operation continued after detection (warning)
6	Undertorque detection at any time during operation/operation continued after detection (warning)
7	Undertorque detection only during speed agree/output shut off at detection (protective operation)
8	Undertorque detection at any time during operation/output shut off at detection (protective operation)

Frequency Detection

Multi-function terminal function selection
H2-01 to 03
 Frequency detection level **L4-01, L4-03**
 Frequency detection width **L4-02, L4-04**

Various frequencies can be detected by setting the following values in terminal M1-M2, P1 and P2 function selection (H2-01, 02 and 03).

Setting Value	Description	Frequency (Speed) Agree Detection Level Setting Constant No.	Frequency (Speed) Agree Detection Width Setting Constant No.
01	Zero-speed	---	---
02	Frequency agree 1	Frequency reference	
03	Desired frequency agree 1	L4-01 without sign	L4-02
04	Frequency (FOUT) detection 1 (Less than preset value)		
05	Frequency (FOUT) detection 2 (More than preset value)		
13	Frequency agree 2	Frequency reference	
14	Desired frequency agree 2	L4-03 with sign	L4-04
15	Frequency (FOUT) detection 3 (Less than preset value for the specified direction of rotation)		
16	Frequency (FOUT) detection 4 (More than preset value for the specified direction of rotation)		

As shown above, select the detection with or without sign in the Varispeed G7.

The following is the frequency (speed) agree timing chart. The figure shows the case of forward rotation; the direction for reverse rotation without sign is the same. When detection with sign is selected, detection signal against the specified direction of rotation is detected according to the direction of rotation.

(1) Setting Value = 02 : Frequency (speed) agree 1

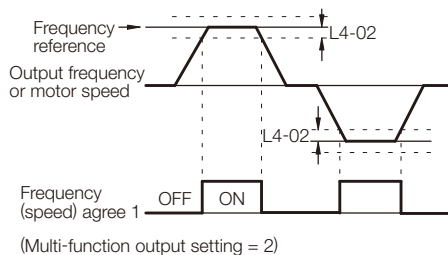

(2) Setting Value = 03 : Desired frequency (speed) agree 1

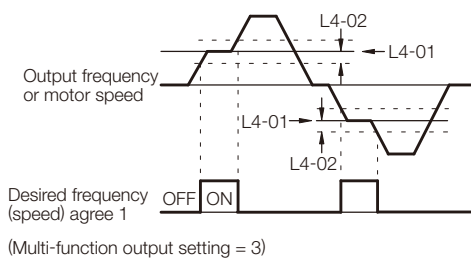

(3) Setting Value = 04 : Frequency (FOUT) Detection 1

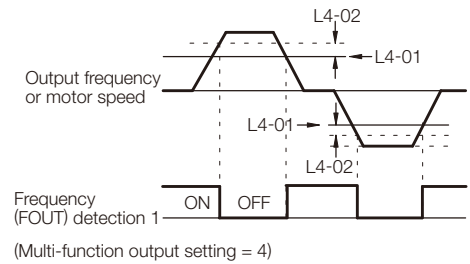

(4) Setting Value = 05 : Frequency (FOUT) Detection 2

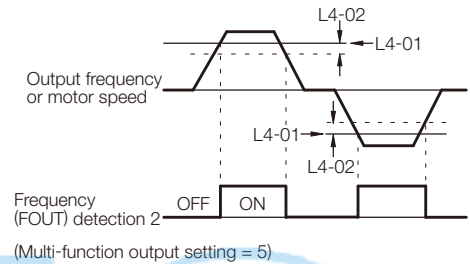

(5) Setting Value = 13 : Frequency (speed) agree 2

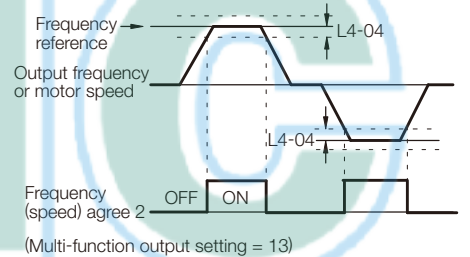

(6) Setting Value = 14 : Desired frequency (speed) agree 2

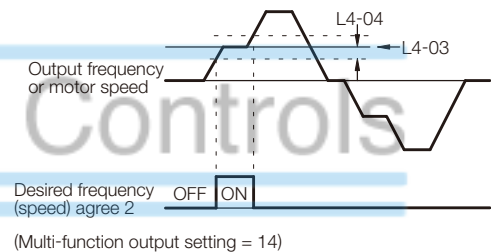

(7) Setting Value = 15 : Frequency (FOUT) Detection 3

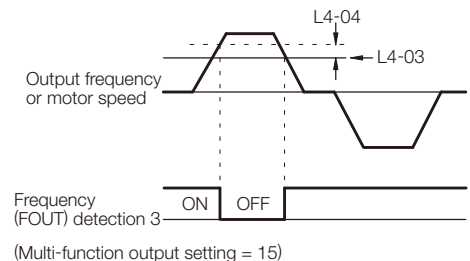

(8) Setting Value = 16 : Frequency (FOUT) Detection 4

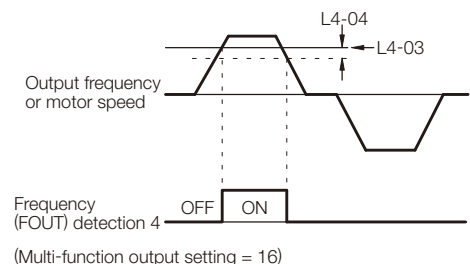

Reduce Motor Noise or Leakage Current

Carrier frequency C6-02

If the wiring between the Inverter and the motor is excessively long, the Inverter output current will be increased because of the increased leakage current of harmonics from the cable, which may affect the peripheral devices.

Refer to the following table to adjust the Inverter output transistor switching frequency (carrier frequency). Reducing such carrier frequency is effective for reduction of radio noise.

Wiring Distance between Inverter and Motor	50 m or less	100 m or less	More than 100 m
Carrier Frequency	15 kHz or less	10 kHz or less	5 kHz or less
C6-02 Value	1 to 6	1 to 4	1 to 2

Note: Factory setting: C6-02 = 6 (15 kHz: 200 V class 18.5 kW or below)

C6-02 Setting Value	Carrier Frequency* (kHz)	Metallic Noise from Motor	Noise and Leakage Current
1	2.0	Large	Less
5			
6	15.0	Small	More

* 2 kHz or more frequency recommended

Use Frequency Meter or Ammeter

Monitor selection (terminal FM) H4-01, H4-04

Analog output signal level selection H4-07, H4-08

Select whether output frequency or output current is to be output to analog monitor output terminals FM-AC or AM-AC.

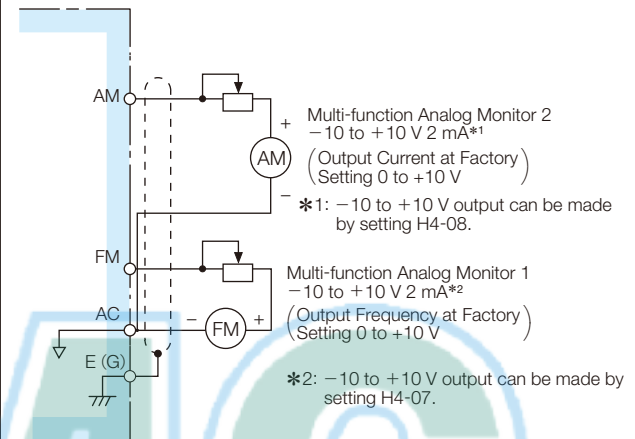

Constant No.	Name	Description
H4-01	Monitor selection (terminal FM)	Set the number of the monitor item to be output from terminal FM or AM. (Number in the part [] of U1-[] 4, 10 to 14, 25, 28, 34, 39 to 42 cannot be set. 17, 23, 29 to 31 and 35 are not used.
H4-04	Monitor selection (terminal AM)	
H4-07	Signal level selection (terminal FM)	Set the signal level of terminal FM or AM.
H4-08	Signal level selection (terminal AM)	0 : 0 to +10 V output 1 : 0 to ±10 V output

Calibrate Indications of Frequency Meter or Ammeter

Analog Monitor Gain H4-02, H4-05
Analog Monitor Bias H4-03, H4-06

Used when analog output terminals FM-AC and AM-AC output voltage with gain and bias.
For gain, set how many times of 10 V the monitor item 100% output is to be made. Set the bias in the units of % assuming that the amount to move the output characteristics upward and downward in parallel is to be 10 V/100%.

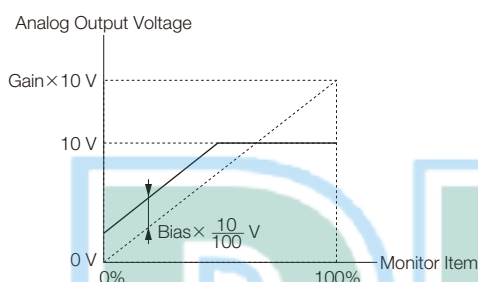

Bias can be set in the range from -10 to +10%.

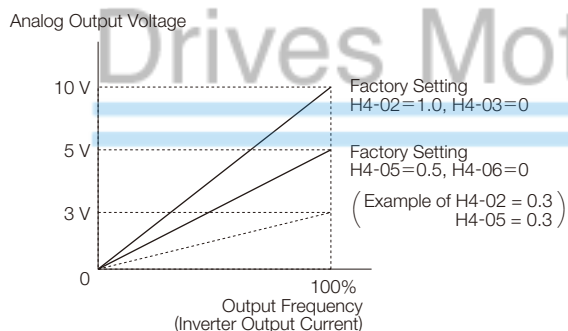
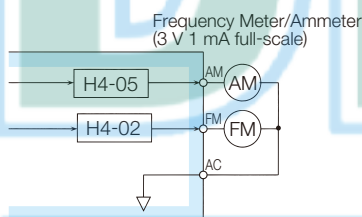

For frequency meter that displays 0 to 60 Hz at 0 to 3 V
 $10 \text{ V} \times (\text{H4-02} = 0.3) = 3 \text{ V}$
This is the voltage when the output frequency is 100%.

Note: Set 1.00 when using a 10 V full-scale meter.

Use Pulse Monitor

Pulse train monitor selection H6-06
Pulse train monitor scaling H6-07

Outputs the monitor items [U1-□□ (status monitor)] of the digital operator from pulse monitor terminals MP-SC. Set H6-06 to the numerical value in □□ of U1-□□ (status monitor). (Only the following 6 items can be output.)

H6-06 Setting Value	Output Item
1	Frequency reference (U1-01)
2	Output frequency (U1-02)
5	Motor speed (U1-05)
20	Output frequency after soft-start (U1-20)
24	PID feedback (U1-24)
36	PID input (U1-36)

When the value of an output item is 100%, set H6-07 to the number of pulses to be output in the units of Hz.

To use the pulse monitor, connect the peripheral devices according to the following load conditions. If any of the following load conditions is not met, sufficient characteristics may not be obtained or the devices may be damaged.

Used as source output

Output Voltage (Insulation Type) VRL (V)	Load Impedance (kΩ)
+5 V or more	1.5 kΩ or more
+8 V or more	3.5 kΩ or more
+10 V or more	10 kΩ or more

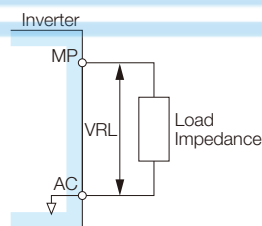

Used as sink input

External Power Supply (V)	12 VAC ± 10%, 15 VDC ± 10%
Sink Current (mA)	Up to 16 mA

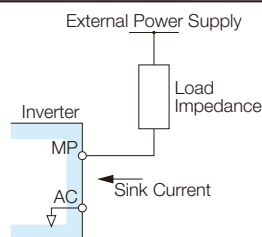

3. Select Stopping Method

Cont'd

Select Stopping Method

Stopping method selection b1-03

To stop the Inverter when a stop command is given, select one of the following four methods according to the application.

Setting	Stopping Method
0	Deceleration stop
1	Coasting to stop
2	Entire area DC injection braking at stop
3	Coasting to stop with timer

However, when using vector control with PG, Entire area DC injection braking at stop (setting=3) and Coasting to stop with timer (setting=4) cannot be selected.

(1) Deceleration stop

By setting b1-03 to 0, the motor decelerates to stop according to the selected deceleration time. When output frequency is less than b2-01 at deceleration to a stop, DC injection braking is applied for the time set to b2-04.

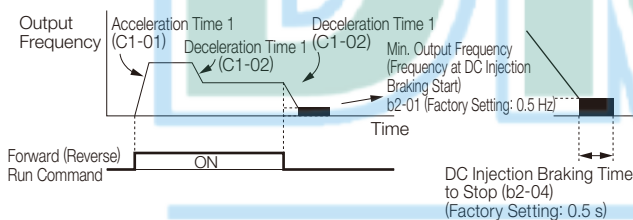

Note: When using vector control with PG, the stopping method varies according to Operation selection for setting of min. output frequency (E1-09) or less (b1-05). Contact your Yaskawa representative for details.

(2) Coasting to stop

By setting b1-03 to 1, the Inverter output voltage is shut off at the same time as run command OFF. The motor coasts to a stop in the deceleration ratio suitable for the inertia and machine loss including the load.

Restart is accepted immediately after the run command is turned OFF, but restart command during rotation of the motor may cause alarms for OV or OC.

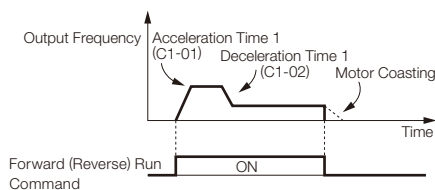

(3) Entire area DC injection braking to stop

By setting b1-03 to 2, the Inverter stops by applying DC injection braking when L2-03 (minimum baseblock time) elapses after turning OFF the run command.

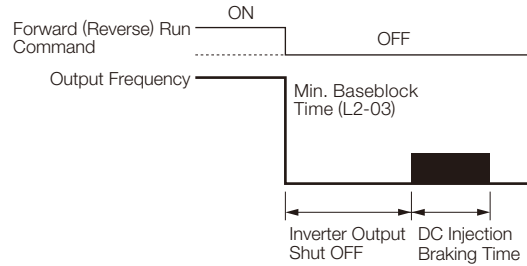

The DC injection braking time is as follows, according to the output frequency when stop command is input.

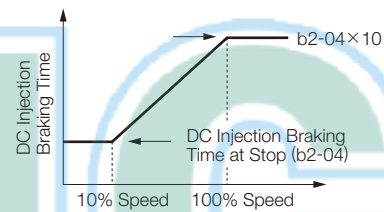

(4) Coasting to stop with timer

By setting b1-03 to 3, the Inverter output voltage is shut off at the same time as run command OFF and the motor coasts to a stop. At this time, the run command is disregarded until operation waiting time T elapses.

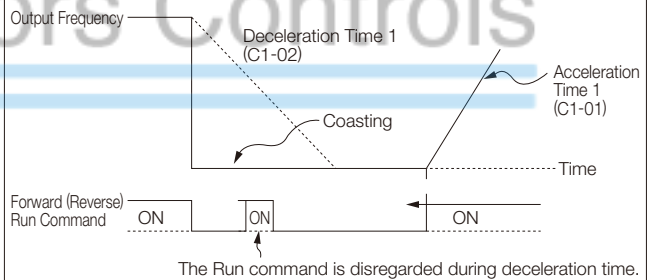

Example when Accel/Decel Time 1 is Selected

Operation waiting time T is as follows according to the output frequency and deceleration time at run command OFF.

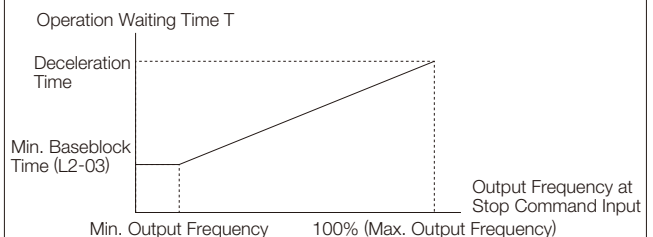

4. Build Interface Circuits with External Devices

Use Input Signals

Multi-function input H1-01 to 10

Functions of the multi-function input terminals S3 to S12 can be changed as necessary by setting constants H1-01 to H1-10.

The same values cannot be set in each constant.

- Function of terminal S3 : Set in H1-01.
- Function of terminal S4 : Set in H1-02.
- Function of terminal S5 : Set in H1-03.
- Function of terminal S6 : Set in H1-04.
- Function of terminal S7 : Set in H1-05.
- Function of terminal S8 : Set in H1-06.
- Function of terminal S9 : Set in H1-07.
- Function of terminal S10 : Set in H1-08.
- Function of terminal S11 : Set in H1-09.
- Function of terminal S12 : Set in H1-10.

Select the function of the input signal by control circuit terminals S3 to S12.

Setting	Function	Control Mode					
		V/f without PG	V/f with PG	Open Loop Vector1	Vector with PG	Open Loop Vector2	Vector with PG
0	3-wire control, forward/reverse selection	○	○	○	○	○	○
1	Local/remote selection	○	○	○	○	○	○
2	Option/Inverter selection	○	○	○	○	○	○
3	Multi-step reference 1	○	○	○	○	○	○
4	Multi-step reference 2	○	○	○	○	○	○
5	Multi-step reference 3	○	○	○	○	○	○
6	Jog frequency reference	○	○	○	○	○	○
7	Accel/decel time selection 1	○	○	○	○	○	○
8	External baseblock NO	○	○	○	○	○	○
9	External baseblock NC	○	○	○	○	○	○
A	Accel/decel stop hold	○	○	○	○	○	○
B	Overheat 2 alarm signal	○	○	○	○	○	○
C	Multi-function analog input selection	○	○	○	○	○	○
D	No speed V/f control with PG	×	○	×	×	×	×
E	ASR integral reset	×	○	×	○	○	○
F	Terminal not used	—	—	—	—	—	—
10	UP command	○	○	○	○	○	○
11	DOWN command	○	○	○	○	○	○
12	Forward jog	○	○	○	○	○	○
13	Reverse jog	○	○	○	○	○	○
14	Fault reset	○	○	○	○	○	○
15	Emergency stop (NO contact)	○	○	○	○	○	○
16	Motor changeover	○	○	○	○	○	○
17	Emergency stop (NC contact)	○	○	○	○	○	○
18	Timer function input	○	○	○	○	○	○
19	PID disable	○	○	○	○	○	○
1A	Accel/decel time selection 2	○	○	○	○	○	○
1B	Program enable	○	○	○	○	○	○
1C	+ speed frequency	○	○	○	○	○	○
1D	- speed frequency	○	○	○	○	○	○
1E	Analog frequency reference sample/hold	○	○	○	○	○	○
20 to 2F	External fault (can be set freely)	○	○	○	○	○	○
30	PID integral reset	○	○	○	○	○	○
31	PID integral hold	○	○	○	○	○	○
32	Multi-step speed reference 4	○	○	○	○	○	○
34	PID SFS ON/OFF	○	○	○	○	○	○
35	PID input characteristics changeover	○	○	○	○	○	○
60	DC injection activate	○	○	○	○	○	○
61	External search command 1 : maximum output frequency	○	×	○	○	○	○
62	External search command 2 : frequency reference	○	×	○	○	○	○
63	Field weakening command	○	○	×	×	×	×
64	External search command 3	○	○	○	○	○	○
65	KEB (deceleration at momentary power loss) command (NC contact)	○	○	○	○	○	○
66	KEB (deceleration at momentary power loss) command (NO contact)	○	○	○	○	○	○
67	Communication test mode	○	○	○	○	○	○
68	HSB (high-slip braking)	○	○	×	×	×	×
71	Speed/torque control change (ON: torque control)	×	×	×	○	○	○
72	Zero-servo command (ON: zero-servo)	×	×	×	○	○	×
77	ASR proportional gain switch (ON: C5-03)	×	×	×	○	○	○
78	Polarity reversing command for external torque reference	×	×	×	○	○	○
79	Brake ON signal (Brake signal)	×	×	×	×	○	○

- (1) For 3-wire sequence (Operation by automatic return contact)
(Example of H1-03 = 0 setting)

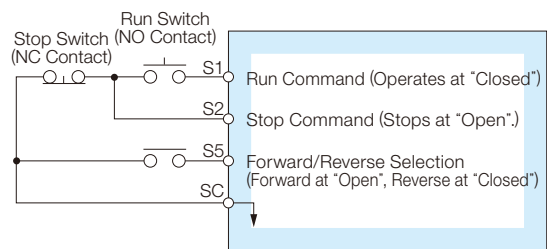

- Note: To set the 3-wire sequence, follow these procedures.
- Set the parameter for the multi-function input terminal and wire the control circuit.
 - Set terminal S5 (H1-03) to 0.

- (2) Local (digital operator)/Remote (control circuit terminal) selection (setting: 01)

Select digital operator or control circuit terminal to operate. Local/remote can be switched only while the motor is held.

Open : Operates according to the setting of REMOTE operation mode (b1-01, b1-02).

Closed : Operates in LOCAL mode by the frequency reference, run command from the digital operator.

(Example) It can be switched between the digital operator and control circuit terminal by setting b1-01 = 1 or b1-02 = 1

Open : Can accept frequency reference (terminal A1), run command (terminals S1, S2) from control circuit terminal.

Closed : Can accept frequency reference, run command from digital operator.

- (3) UP/DOWN command (setting: 10, 11)

Accel/decel to the desired speed can be accomplished while the forward (reverse) run command is enabled, without changing the frequency reference, by inputting the UP/DOWN by remote signal.

UP Command	Closed	Open	Open	Closed
DOWN Command	Open	Closed	Open	Closed
Operation	Accel	Decel	HOLD	HOLD

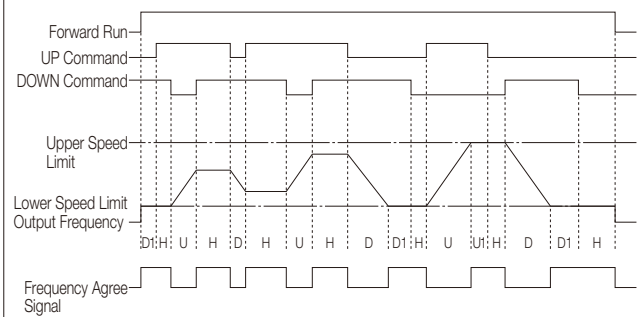

Time Chart when UP/DOWN Command is Used

(Symbols)

U : UP (acceleration) status

D : DOWN (deceleration) status

H : HOLD (constant speed) status

U1 : UP status, but clamped at upper speed limit

D1 : DOWN status, but clamped at lower speed limit

- Note: 1. When using the UP/DOWN command, always set b1-01 at (frequency reference).
 Setting value = 1 : enables the UP/DOWN command.
 Setting value = other than 1 : disables the UP/DOWN command.
- The upper speed limit is: Max. output frequency (E1-04) × frequency reference upper limit (d2-01).
 - The lower speed limit is: Max. output frequency × frequency reference lower limit (d2-02) and the largest of main frequency references inputs via the control circuit terminal A1.
 - When frequency reference command storage function is provided (d4-01 = 1), the output frequency is stored even after the power is turned OFF with the accel/decel hold (HOLD) command input. If d4-01 = 0, the held output frequency is not stored.
 - When JOG command is input during operation by UP/DOWN command, JOG command is prioritized.
 - Setting error (OPE03) occurs if the UP/DOWN command is not set at the same time.
 - Setting error (OPE03) occurs if multi-function input accel/decel hold (HOLD) command is set at the same time.

(4) Timer function (setting: 18)

The external Inverter timer can be combined with the timer input (setting = 18) and the multi-function output terminal timer output (setting = 12), to set the internal Inverter timer.
 Set the ON side delay time in 0.1-second unit.
 Set the OFF side delay time in 0.1-second unit.

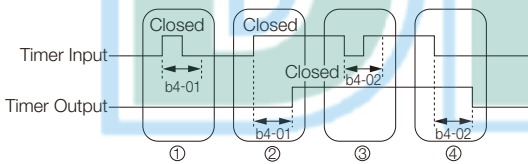

[Operation]

- When the timer input "closed" time is shorter than b4-01, the timer output stays "open".
- When the timer input becomes "closed", the timer output closes after the time set in b4-01.
- When the timer input "open" time is shorter than b4-02, the timer output stays "closed".
- When the timer input becomes "open", the timer output closes after the time set in b4-02.

Use Output Signals

Multi-function terminal selection H2-01 to 05

Constants H2-01 to -05 can be used to change the functions of the multi-function output terminals M1-M2, P1-PC to P4-C4 as necessary.

- Terminal M1-M2 function: Set in H2-01.
- Terminal P1-PC function: Set in H2-02.
- Terminal P2-PC function: Set in H2-03.
- Terminal P3-C3 function: Set in H2-04.
- Terminal P4-C4 function: Set in H2-05.

Setting	Function	Control Mode				
		V/f without PG	V/f with PG	Open Loop Vector1	Open Loop Vector with PG	Open Loop Vector2
0	During run	○	○	○	○	○
1	Zero speed	○	○	○	○	○
2	Frequency (speed) agree 1	○	○	○	○	○
3	Optional frequency (speed) agree 1	○	○	○	○	○
4	Frequency (FOUT) detection 1	○	○	○	○	○
5	Frequency (FOUT) detection 2	○	○	○	○	○
6	Inverter ready (READY)	○	○	○	○	○
7	Main circuit undervoltage (UV) detection	○	○	○	○	○
8	Baseblock (NO contact)	○	○	○	○	○
9	Frequency reference selection status	○	○	○	○	○
A	Run command status	○	○	○	○	○
B	Overtorque/undertorque detection 1 (NO contact)	○	○	○	○	○
C	Frequency reference loss	○	○	○	○	○
D	Mounted-type braking resistor fault	○	○	○	○	○
E	Fault	○	○	○	○	○
F	Not used	—	—	—	—	—
10	Minor fault (ON: when warning displayed)	○	○	○	○	○
11	Reset command active	○	○	○	○	○
12	Timer function output	○	○	○	○	○
13	Frequency (speed) agree 2	○	○	○	○	○
14	Optional frequency (speed) agree 2	○	○	○	○	○
15	Frequency (FOUT) detection 3	○	○	○	○	○
16	Frequency (FOUT) detection 4	○	○	○	○	○
17	Overtorque/undertorque detection 1 (NC contact)	○	○	○	○	○
18	Overtorque/undertorque detection 2 (NO contact)	○	○	○	○	○
19	Overtorque/undertorque detection 2 (NC contact)	○	○	○	○	○
1A	Reverse direction	○	○	○	○	○
1B	Baseblock 2 (NC contact)	○	○	○	○	○
1C	Motor selection (second motor selected)	○	○	○	○	○
1D	During regeneration	×	×	×	○	○
1E	Fault restart enabled	○	○	○	○	○
1F	Motor overload OL1 (including OH3) alarm prediction	○	○	○	○	○
2F*	Maintenance Time ON: The operation time of either the electrolytic capacitors or the cooling fan has reached the specified maintenance time.	○	○	○	○	○
20	Inverter overheat prediction, OH alarm prediction	○	○	○	○	○
30	Torque limit (current limit)	×	×	○	○	○
31	During speed limit (ON: during speed limit)	×	×	×	○	×
32	Speed control circuit operating for torque control (except when stopped).	×	×	×	○	○
33	Zero-servo end (ON: zero-servo function completed)	×	×	×	○	×
36	Frequency (FOUT) detection 5	○	○	○	○	○
37	During run 2	○	○	○	○	○
3D	Inverter's Cooling Fan Fault detected	○	○	○	○	○

* The constants are available only for versions PRG: 1039 or later.

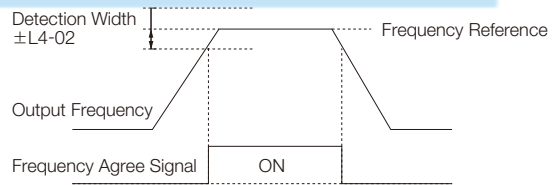

Frequency Agree Signal Setting Example (Setting = 2)

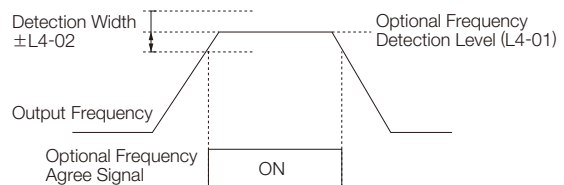

Optional Frequency Agree Signal Setting Example (Setting = 3)

5. Adjust Motor Torque

Compensate for Torque at Start/ Lowspeed Operation

Torque compensation gain C4-01

Torque compensation is a function to detect the increase of the motor load and increase output torque. If control method selection (A1-02) is set to 0 (V/f control without PG) or 1 (V/f control with PG), this function compensates for insufficient torque at start or low-speed operation using the entire area full-automatic torque boost function according to output voltage. When control method selection (A1-02) is set to 2 (openloop vector control), motor torque is automatically controlled according to the load by calculating motor primary current to compensate for undertorque.

Automatic torque compensation gain normally does not need adjustment. Do not adjust the torque compensation gain when using open-loop vector control. The factory setting is C4-01 = 1.0

Make necessary adjustments when the wiring distance between the Inverter and motor is long, or when the motor vibrates excessively.

The motor torque can be increased by increasing the torque offset gain, but may also cause the following failures.

- Excessive motor current may cause failure of the Inverter.
- The motor may heat or vibrate excessively.

Increase the torque offset gain little by little, while observing the motor current.

Limit Motor Torque

Forward torque limit	L7-01
Reverse torque limit	L7-02
Forward regenerative torque limit	L7-03
Reverse regenerative torque limit	L7-04

The motor torque limit function is enabled at vector control with PG and open-loop vector control. Since torque that is output from the motor is calculated internally in the vector control with PG and the open-loop vector control mode, torque limit can be applied with any value. This function is effective when torque exceeding a certain amount is not to be applied to the load or when the regenerative value is not to be generated at a certain amount or more.

Set the torque limit value in the % for the motor rated torque.

It can be set individually in each quadrant.

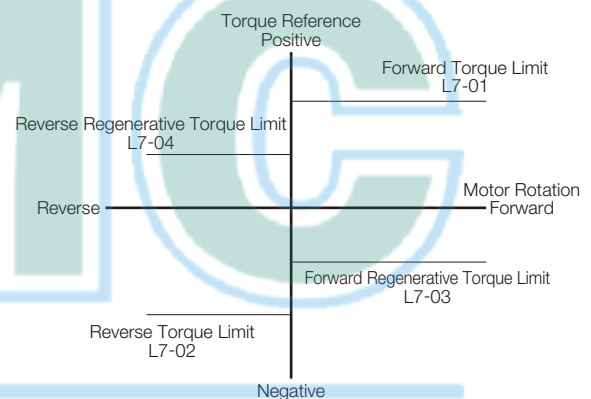

- Note:
- Since torque control has a priority when the torque limit function operates, the motor revolution control or compensation will be disabled. Therefore, accel/decel time may increase or the motor revolutions may reduce.
 - When torque limit is used for lifting load applications, set such a torque limit value that the load may not drop or slip.
 - To increase the torque limit value, the Inverter capacity may have to be increased.

Prevents Motor from Stalling

Stall prevention selection during accel	L3-01
Stall prevention level during accel	L3-02
Stall prevention limit during accel	L3-03
Stall prevention selection during decel	L3-04
Stall prevention selection during run	L3-05
Stall prevention level during run	L3-06

(1) Stall prevention during acceleration

A function to prevent the motor from stalling when an excessive load is applied to the motor during acceleration or at rapid acceleration.

By setting L3-01 to 1, the motor stops acceleration and holds the frequency if Inverter output current exceeds 150% (L3-02 set value) of Inverter rated current.

When output current is 135% (L3-02 set value – 15%) or less, acceleration starts again. Inverter rated output current is regarded as 100%.

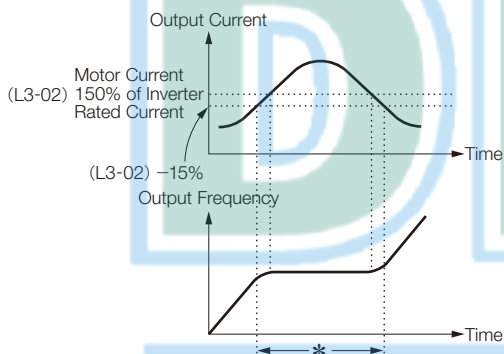

* Output frequency is controlled so that stall status may not be caused in the meantime.

(Factory setting of L3-02 is 150%. By setting L3-01 to 0, the stall prevention during acceleration will be disabled.)

Stall prevention level during acceleration is automatically reduced by the following equation in the constant output area (output frequency \geq max. voltage frequency E1-06).

Stall prevention level during acceleration in constant output area

$$= \text{Stall prevention level during accel (L3-02)} \times \frac{\text{Max. voltage frequency (E1-06)}}{\text{Output frequency}}$$

However, in order to avoid this stall prevention level in the constant output area from being reduced more than necessary, use L3-03 to set the limit.

Note: Factory setting: L3-03 = 50%

(2) Stall prevention during run

Stall prevention during run prevents the motor from stalling by automatically reducing the output frequency from the Inverter whenever a transient overload occurs while the motor is running at a constant speed.

By setting L3-05 to 1 or 2, the stall prevention during running is enabled only in the V/f control mode.

Deceleration starts when Inverter output current exceeds 160% (L3-06 set value) of Inverter rated current during constant speed operation.

While output current exceeds 160% (L3-06 set value), the motor continues decelerating in the set deceleration time. When Inverter output current is 158% (L3-06 set value – 2%) or less, the motor accelerates up to the set frequency in the set acceleration time.

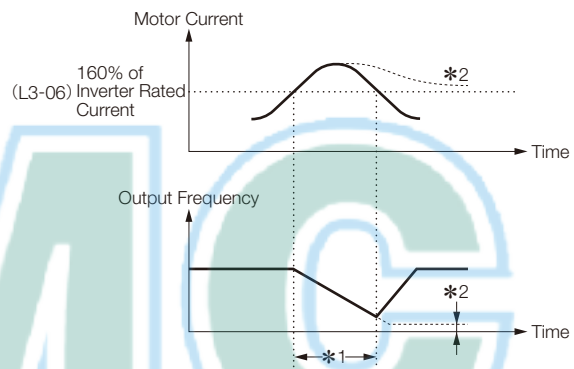

*1: Frequency is reduced to prevent stalling in the meantime.
*2: Unless output current is less than the set level, output frequency is held at the minimum value.

(Factory setting is 120%. By setting L3-05 to 0, the stall prevention during running will be disabled.)

(3) Stall prevention during deceleration

A function to extend the deceleration time automatically according to the size of main circuit DC voltage so that overvoltage may not occur during deceleration. When a braking resistor (optional) is used, be sure to set L3-04 to 0 or 3.

The following shows an example of the stall prevention during deceleration when 1 is set to L3-04.

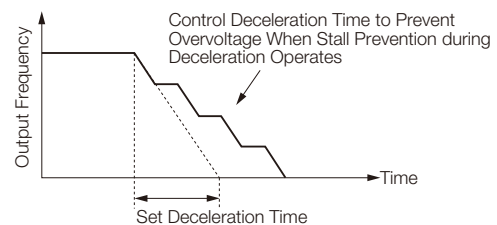

L3-04 Setting	Stall Prevention during Deceleration
0	Disabled
1	Enabled (Stops deceleration when main circuit DC voltage is closed to the overvoltage level. Starts deceleration again after recovery of voltage.)
2	Optimum adjustment (Decelerates in the shortest time according to main circuit DC voltage. Setting of deceleration time is disregarded.)
3	Enabled (when braking resistor is mounted)

6. Reduce Motor Speed Fluctuation

Cont'd

Control Motor Slip

Slip compensation gain	C3-01
Speed control (ASR) proportional (P) gain 1	C5-01
ASR proportional (P) gain 2	C5-03
ASR integral (I) time 1, 2	C5-02, C5-04

As the load becomes larger, the motor slip amount becomes larger, resulting in reduction of the motor speed.

The slip offset function controls the motor speed at a constant rate even when the load changes.

The Inverter adds frequency equivalent to the slip of the motor to the output frequency according to the load. Control with PG is accomplished by directly detecting the motor speed by the PG (detector), thus allowing higher precision in the operation.

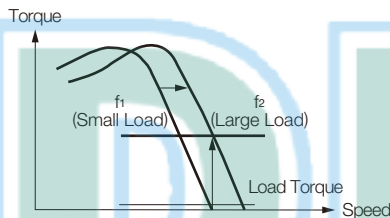

· Control without PG

Constant No.	Name	Setting Range	Initial Value
C3-01	Slip compensation gain	0 to 2.5	1.0*1
E2-01	Motor rated current	0.00 to 1500.0 A	*2
E2-02	Motor rated slip	0.00 to 20.00 Hz	*2
E2-03	Motor no-load current	0.00 to 1500.0 A	*2

· Control with PG

Constant No.	Name	Setting Range	Initial Value
C5-01	ASR proportional gain 1	1.00 to 300.00*3	20.00*4
C5-02	ASR integral time 1	0.000 to 10.000 s	0.500*4
C5-03	ASR proportional gain 2	1.00 to 300.00*3	20.00*4
C5-04	ASR integral time 2	0.000 to 10.000 s	0.500*4
E2-04	Number of motor poles	2 to 48	4
F1-01	PG constant (P/R)	0 to 60000	600

*1: When using V/f control without PG, the initial value is 0.0 (without slip compensation).

*2: Initial value differs according to the Inverter kVA setting or motor selection.

*3: When using V/f control with PG, the setting range is 0.00 to 300.00.

*4: Initial values of V/f control with PG are C5-01=0.20, C5-02=0.20 s, C5-03=0.02, C5-04=0.05 s.

Set the speed control proportional gain (C5-01) and integral time (C5-02) at the maximum output frequency. Set the speed control proportional gain (C5-03) and integral time (C5-04) at the minimum output frequency. Normally, C5-03 and C5-04 do not have to be set.

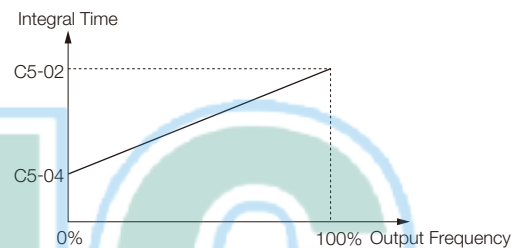
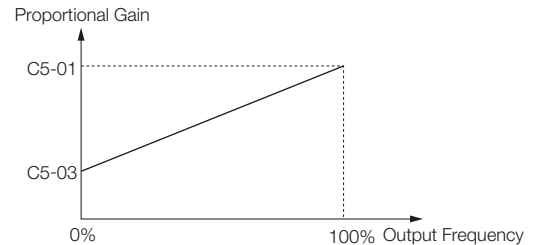

Relation between Output Frequency and Proportional Gain or Integral Time

7. Motor Protection

Cont'd

Motor Overload Detection

Motor rated current	E2-01
Motor protection selection	L1-01
Motor protection time constant	L1-02

The Inverter protects against motor overload with a built-in electronic thermal overload relay. Make the correct settings as follows.

Constant No.	Name	Setting Range	Initial Value
E2-01	Motor rated current	Setting range is from 10 to 200% of the Inverter rated output current.	*
L1-01	Motor protection selection	0 to 3 0 = Disabled (No motor protection) 1 = Protects general-purpose motors. 2 = Protects Inverter exclusive-use motors. 3 = Protects vector control motors.	1
L1-02	Motor protection time constant	0.1 to 5.0 min	1.0 min

* Initial value differs according to the Inverter kVA setting or motor selection.

- Set E2-01 to the rated current value on the motor nameplate. This set value becomes electronic thermal overload relay reference value.
- According to the applicable motor, set L1-01 for the overload protective function. Motor has different cooling capacity depending on the speed control range. Therefore, it is necessary to select the protective characteristics of the electronic thermal overload relay according to the allowable load characteristics of the applicable motor. The table below shows motor types and their allowable load characteristics.
- Set L1-02 to the motor protective operation time. (Normally, this setting is not needed.) Set the electronic thermal overload relay protective operation time when 150% overload is applied after continuous operation at rated current (hot-start). Note: Factory setting: L1-02=1.0 min (150% yield stress)

The following diagram shows an example of protective operation time characteristics of the electronic thermal overload relay [L1-02=1.0 minute, operation at 60 Hz, general-purpose motor characteristics (when L1-01 is set to 1)].

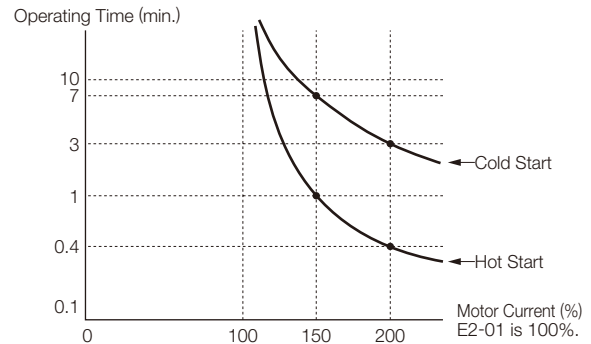

Motor Protective Operation Time

- With the electronic thermal overload relay, motor temperature is simulated based on the Inverter output current, frequency, and time to protect the motor from overheating. When electronic thermal overload relay is enabled, an "OL1" error occurs, shutting OFF the Inverter output and preventing excessive overheating in the motor. When operating with one Inverter connected to one motor, an external thermal relay is not needed.
- When operating several motors with one Inverter, install a thermal relay on each motor. In this case, set constant L1-01 to 0.
- Thermal overload calculated value is reset when the power supply is turned OFF so that protection may not be enabled in applications where the power supply is frequently turned ON and OFF even if L1-01 is set to either 1, 2 or 3.

Motor Type and Allowable Load Characteristics

L1-01 Setting	1	2	3	
Motor type	General-purpose Motor (Standard Motor)	Constant Torque Inverter Exclusive-use Motor(1:10)	Vector Exclusive-use Motor (1:100)	Vector with PG Exclusive-use Motor (1:1000)
Allowable Load Characteristics				
Cooling Ability	Motor to operate with commercial power supply. Has motor configuration where cooling effect can be obtained when operating at 50/60 Hz.	Has motor configuration where cooling effect can be obtained even if operating in low-speed area (approx. 6 Hz).	Has motor configuration where cooling effect can be obtained even if operating at super low-speed area (approx. 0.6 Hz).	Has motor configuration where cooling effect can be obtained even if operating at super low-speed area (approx. 0.6 Hz).
Electronic Thermal Overload Relay Operation (at 100% Motor Load)	Detects motor overload protection (OL1) at continuous operation at less than 50/60 Hz. Inverter outputs a fault contact and the motor coasts to a stop.	Performs continuous operation at 6 to 50/60 Hz.	Performs continuous operation at 0.6 to 60 Hz.	Performs continuous operation at 0.06 to 60 Hz.

8. PID Control

Cont'd

PID Control

PID control selection	b5-01
Reference selection	b1-01
Terminal A2 signal level selection	H3-08
PID constant	b5-02 to 10

PID control makes the set reference selection coincide with the feedback value (detected value). By combining proportional control (P), integral control (I) and differential control (D), PID control is enabled even for applications (machine systems) having idle time.

Each control feature of PID control is as follows:

- P control:** Outputs the operation amount in proportion with the deviation. However, the deviation cannot be made zero only by P control.
- I control:** Outputs the operation amount obtained by integrating the deviation. Effective to make the feedback value coincide with the reference selection. However, cannot follow up with rapid variation.
- D control:** Outputs the operation amount obtained by differentiating the deviation. Can respond promptly to rapid variations.

b5-01 Setting	PID Control Function
0	Disabled
1	Enabled (Deviation is D controlled.)
2	Enabled (Feedback value is D controlled.)
3	Enabled (frequency reference + PID output, D control of deviation)
4	Enabled (frequency reference + PID output, D control of feedback value).

(1) Reference selection setting

The frequency reference selected by b1-01 or the frequency reference selected by multi-step speed reference 1, 2 or 3 will be the reference selection for PID control. However, the reference selection can be set as shown in the following table.

How to Set PID Reference Selection	Setting Conditions
Input from Multi-function Analog Terminal A2 and A3*	Set b1-01 to 1 and H3-09 or H3-05 to C (PID reference selection). At this time, set H6-01 to 1 (PID feedback value) and input the detected value to pulse train input terminal RP.
Input from MEMOBUS Communication Register 0006H	Set b1-01 to 2 and bit of MEMOBUS register 000FH to 1, and register 0006H can be input as the PID reference selection through communications.
Input from Pulse Train Input Terminal RP	Set b1-04 to 4 and H6-01 to 2 (PID reference election)

* Terminal A2 current signal (4 to 20 mA) or voltage signal (0 to 10 V) can be used.

Terminal A2 current signal: H3-08 = 2

Terminal A2 voltage signal : H3-08 = 0

(When the voltage signal is used, turn OFF dip switch S1-2)

(2) Detected value setting

The setting of the detected value can be selected from the following table.

How to Input	Setting Conditions
Input from Multi-function Analog Terminal A2 and A3*	Set H3-09 or H3-05 to B (PID feedback value).
Input from Pulse Train Input Terminal RP	Set H6-01 to 1 (PID feedback value).

* Same as the description for the above table.

- The integral value is reset to 0 in the following cases:
 - When stop command is input or during stop
 - When multi-function input PID control cancel (set value: 19) is selected, and terminal PID is set as "PID control cancel" when "closed"
- The upper limit of I can be set by b5-04. When upgrading the control capacity by integration, increase the value of b5-04.
- If the control system vibrates and cannot be corrected by adjusting the integral time or primary delay time constant, decrease the b5-04 value.
- The PID control can be canceled by the multi-function input signal. The PID control is canceled by setting 19 in one of H1-01 to 10, and closing the contact; the reference selection signal is directly used as the frequency reference signal.

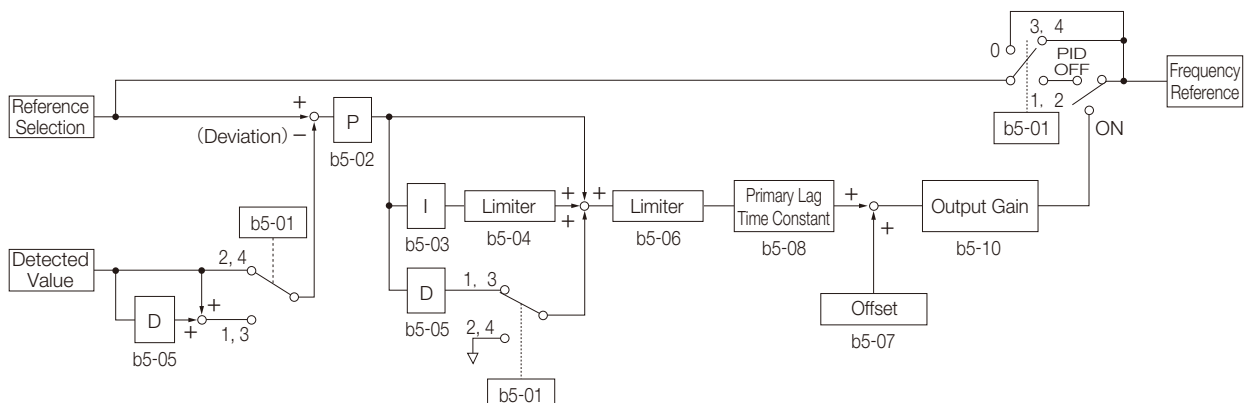

PID Control Block Diagram

9. Control by MEMOBUS Communication

Cont'd

Reference selection	b1-01
Operation method selection	b1-02
Slave address	H5-01
Transmission speed selection	H5-02
Transmission parity selection	H5-03
Stopping method after communication error	H5-04
Communication error detection selection	H5-05
Send wait time	H5-06
RTS control ON/OFF	H5-07
MEMOBUS communication error code	U1-39

The Varispeed G7 can perform serial communications with the programmable controller (hereafter referred to as PLC) using the MEMOBUS protocol. MEMOBUS communications are configured using one master (PLC) and a maximum of 31 slaves (Varispeed G7). In the signal transmission (serial communication) between the master and the slave(s), the master always starts signal transmission and the slaves respond to it.

The master performs signal transmission simultaneously with one slave. Therefore, set address number for each slave in advance, and the master can specify the number for signal transmission. The slave that receives the command from the master executes the specified function, and returns a response to the master.

[Communication specifications]

- Interface : RS-485/422
- Synchronization : Non-synchronous (start stop synchronization)
- Communication parameter :
 - Can be selected from baud rate 2400, 4800, 9600 or 19200 bps (constant H5-02).
 - Data length 8-bit fixed
 - Parity with/without parity, odd/even parity selectable (constant H5-03)
 - Stop bit 1 bit fixed
- Protocol : MEMOBUS or equivalent (RTU mode only)
- Max. connection : 31 units (when RS-485 is used)

[Data that can be transmitted/received on-line]

Data that can be transmitted/received on-line are the run command, frequency reference, fault, Inverter status, constant setting/reference.

(1) Operation mode selection (b1-01, b1-02)

Select the run command and frequency reference input method in constants b1-01 and b1-02, respectively. To provide a run command and frequency reference by communication, set these constants to setting 2. Also without regard to this selection, monitoring of running status, constant setting/reference, fault reset and multi-function input command from the PLC are enabled. The multi-function input command becomes OR with the command input from control circuit terminals S3 to S12.

(2) MEMOBUS frequency reference unit (o1-03)

The frequency reference units from the PLC and in the frequency reference and output frequency monitors (by communication) are selected.

(3) MEMOBUS slave address (H5-01)

The slave address number is set. It is necessary to set the address number so that it will not overlap with the address number of another slave connected on the same transmission line.

Note: To change the values set in constant H5-01 to H5-07 and enable new settings, it is necessary to turn OFF the power supply, and then turn it ON again.

(4) MEMOBUS communication error code (U1-39)

If an error occurs in the MEMOBUS communication, the error contents can be displayed on the digital operator.

Memobus Error Code

U1-39 = 01111011

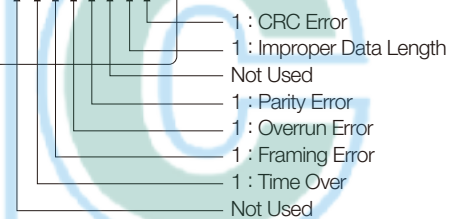

10. Energy-saving Control

Use Energy-saving Mode

Energy-saving mode selection	b8-01
Energy-saving coefficient	b8-04

Set b8-01 (energy-saving mode selection) to 1, and energysaving control is enabled.

b8-01 Setting	Energy-saving Mode
0	Energy-saving disabled
1	Energy-saving enabled

For the constants used in the energy-saving mode, the optimum values have been set at factory. They do not have to be adjusted under normal operation. If the motor has very different characteristics from those of Yaskawa standard motors, refer to the following description of the constants and change them. The following describes the case where constant A1-02 is set to 0 (V/f control without PG) or 1 (V/f control with PG).

Energy-saving coefficient (b8-04)

In the energy-saving mode, the voltage at which the motor efficiency will be the maximum is calculated using this energy-saving coefficient, which is regarded as output voltage reference. This value has been set to the Yaskawa standard motors as the factory setting. Increasing the energy-saving coefficient makes output voltage larger.

When using any motor other than Yaskawa standard motors, change the value by approx. 5% from the factory setting so that you can find the optimum value in which output power will be the minimum.

11. Use Constant Copy Function

Copy or Compare Constants

Copy function selection	o3-01
Read permitted selection	o3-02

The Varispeed G7 standard digital operator (JVOP-160) can store the Inverter constants. The constant capacity to be stored is for one unit. Since EEPROM (non-volatile memory) is used as the data memory elements, any backup power supply is not needed.

Copy function selection (o3-01)

Constants can be written (copied) only between the Varispeed G7 units with the same product code, software number, capacity and control mode (V/f control without PG, V/f control with PG, open-loop vector control or vector control with PG). If the conditions are not met, the digital operator displays an error such as CPE (ID unmatched), vAE (Inverter capacity unmatched) or CrE (control mode unmatched).

The digital operator uses the incorporated EEPROM to perform the following three functions:

- Stores Inverter constant set values in the digital operator (READ).
- Writes in the constant set values stored in the digital operator to the Inverter (COPY).
- Compares the Inverter constants with the constants stored in the digital operator (VERIFY).

(Factory setting: o3-01 = 0)

o3-01 Setting	Contents
0	Normal operation
1	READ (from Inverter to operator)
2	COPY (from operator to Inverter)
3	VERIFY (comparison)

(1) READ

Set o3-01 to 1 so that the Inverter constant set values will be stored in the digital operator.

(2) COPY

Set o3-01 to 2 so that the constant set values stored in the digital operator will be written in to the Inverter. (Use the copy function off-line.)

(3) VERIFY

Set o3-01 to 3 so that the Inverter constants will be compared with the constant set values in the digital operator.

Read permitted selection (o3-02)

Prohibition of constant read-out from the Inverter can be set. By using this function, you can prevent the constant stored in the EEPROM of the digital operator from being changed by mistake.

(Factory setting: o3-02 = 0)

o3-02 Setting	Contents
0	READ prohibited
1	READ permitted

By setting o3-02 to 0, reading operation is disabled so that the constant data stored in EEPROM of the digital operator can be protected.

Conveyor and Lifter (Insures Safe and Optimum Performance)

Example of Use in Shuttle Conveyor for Car Parts

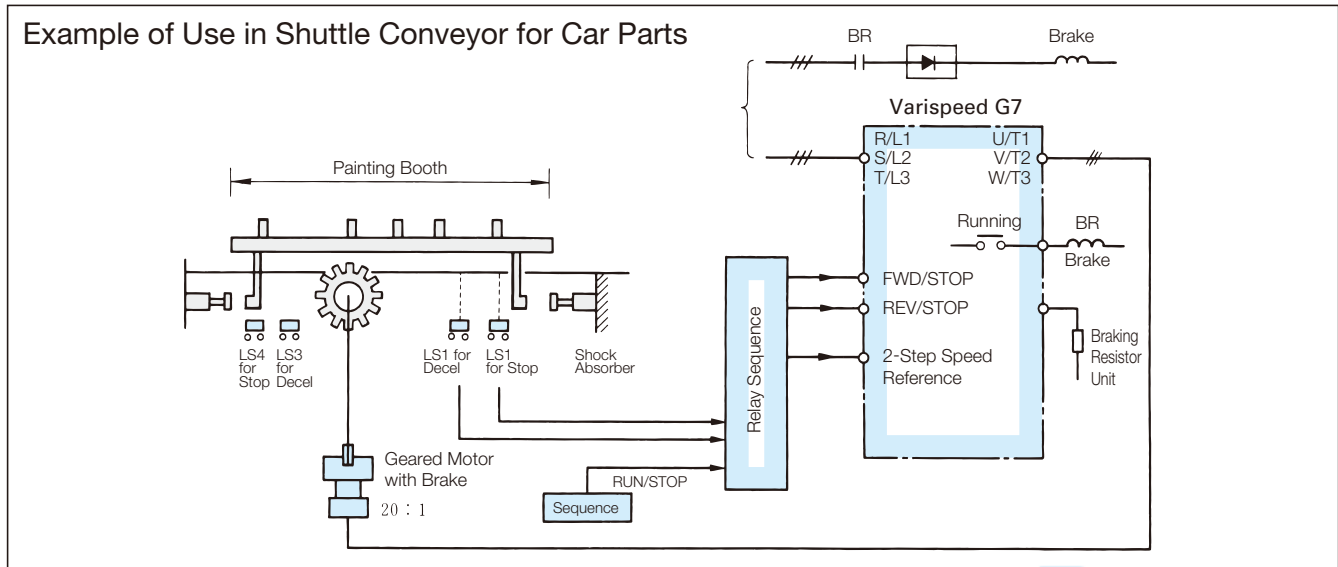

Operation Chart

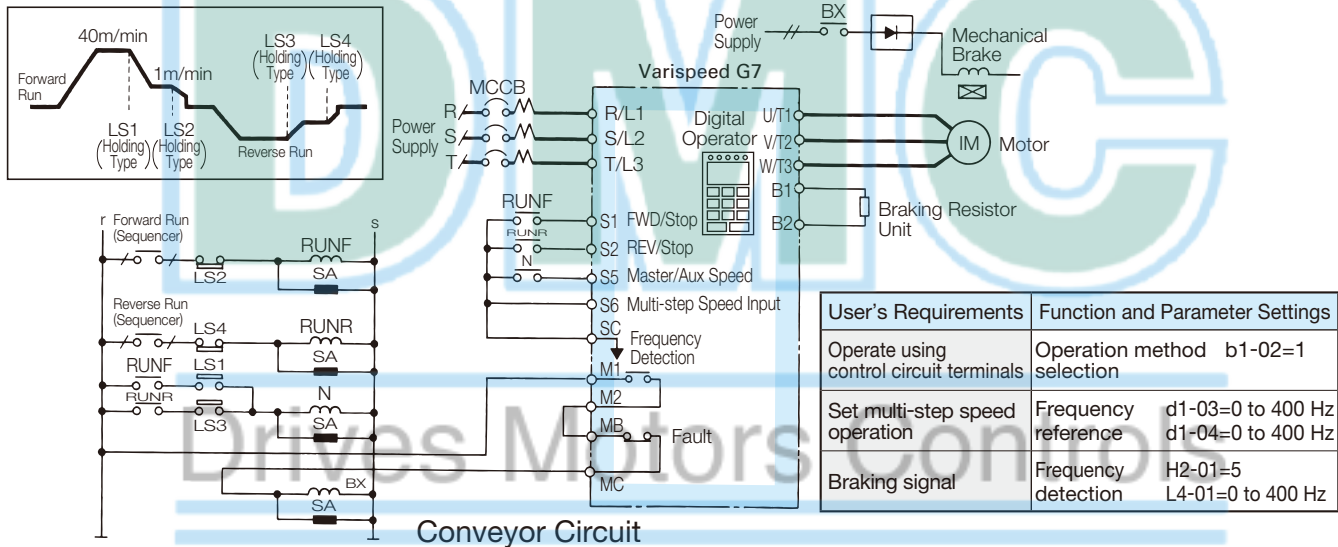

Conveyor Circuit

Application Example	User's Requirements	Applicable Varispeed G7 Function	Function and Parameter Settings
Shuttle Conveyor	Increase precision of positioning stop.	Control the braking motor using contact output from terminals M1 and M2.	Operation method selection b1-02=1 Slip prevention H2-01=5 L4-01=0 to 400 Hz
	Perform 2-step speed operation.	Use the multi-step speed function.	Frequency reference d1-01 to 04=0 to 400 Hz
	Smooth accel/decel	Apply S-curve accel/decel.	S-curve accel/decel C2-01 to 04 = 0.0 to 2.5 sec.
	Variable accel/decel time	Use the accel/decel time setting function.	Accel/decel time switching H1-01 to 10=7
	Select stop procedure according to degree of emergency.	Select stop procedures.	External fault H1-01 to 10=20 to 2F
Raw Material Input Conveyor	Increase starting torque (with a constant-torque motor).	Increase torque limit value.	Torque limit L7-01 to 04=0 to 300%*
Steel Pipe Conveyor	Drive more than one motor with a single Inverter.	The function is provided. (Select V/f mode)	Control method selection A1-02=0
Lifter	Simple slip compensation function.	Check the motor generation torque using the torque detection function.	Over torque detection L6-01, 04 = 0-4 Over torque detection level L6-02, 05 = 0 to 300% Over torque detection time L6-03, 06 = 0 to 10.0 sec.
	Use non-excitation operating type braking motor.	Use the user-defined V/f pattern to turn the motor without excess excitation.	Control method selection A1-02 = 0 V/f selection E1-03 = F User-defined V/f setting E1-04 to 10 = Setting

* Inverter capacity cannot be exceeded. Choose larger Inverter capacity for the maximum torque required.

Lathe (Sufficient Interface Circuit to NC, Improves Rapid Accel/Decel Performance)

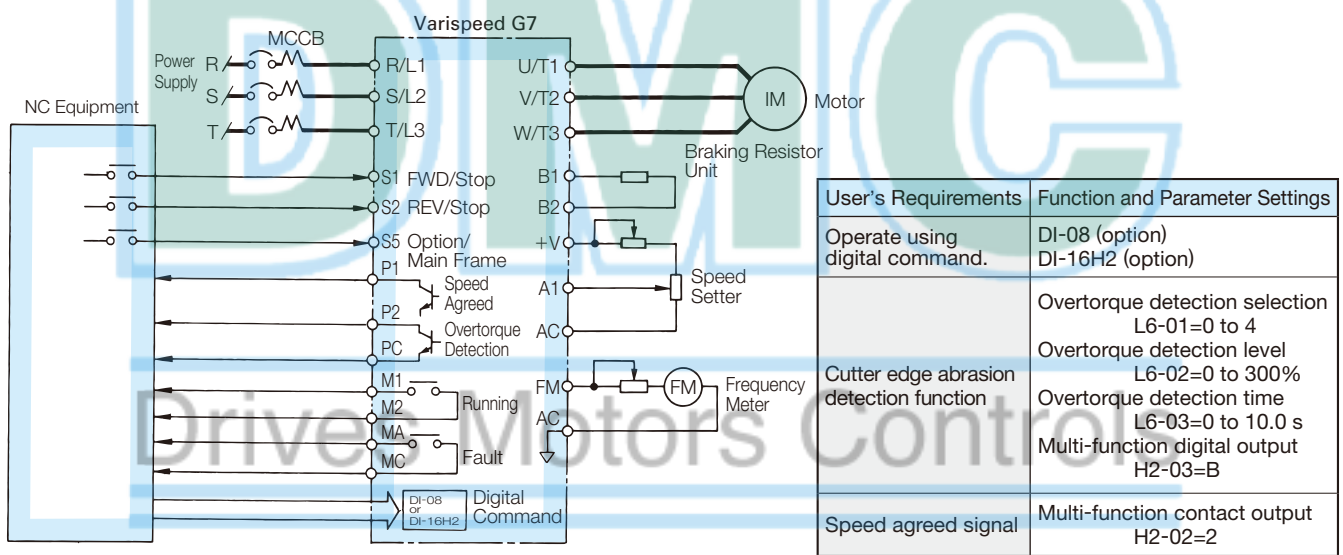
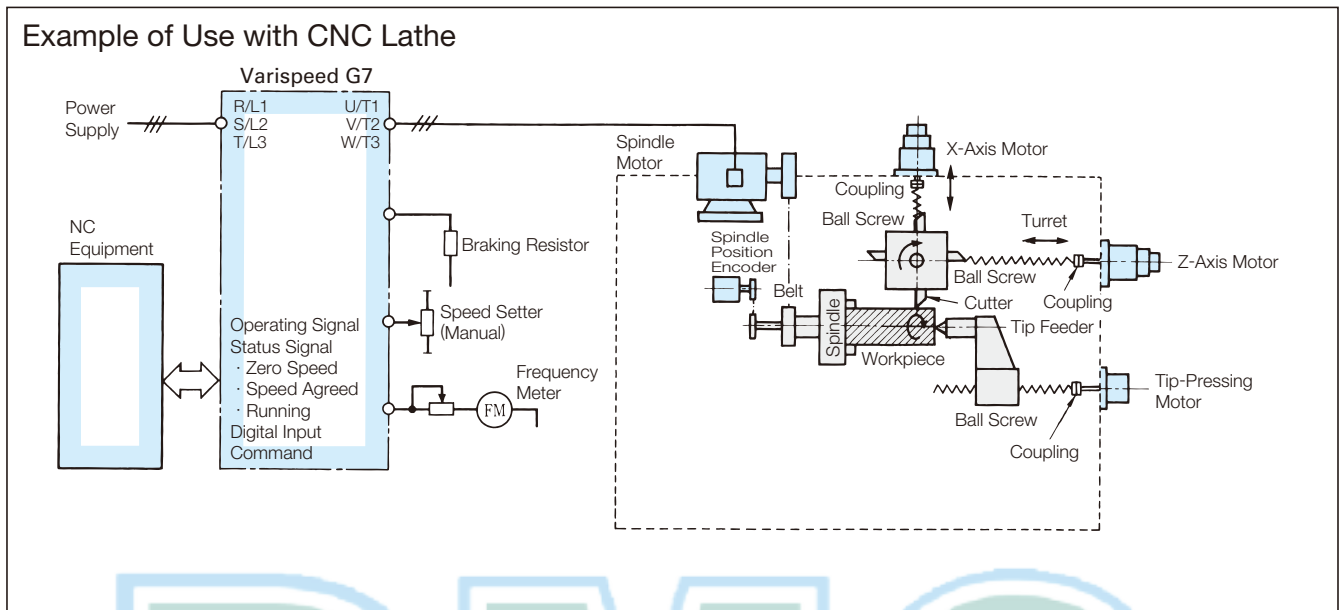

Interface Circuit to NC

Application Example	User's Requirements	Applicable Varispeed G7 Function	Function and Parameter Settings	
CNC Lathe	Cutting loss detection function	Apply the overtorque detection function.	Overtorque detection selection L6-01, 04=0 to 4 Overtorque detection level L6-02, 05=0 to 300% Overtorque detection time L6-03, 06=0 to 10.0 s Multi-function digital output H2-01 to 05=B	
	Drive the motor with digital input.	Use the Digital Reference Card.	Connect Frequency reference setting mode DI-08 or -DI-16H2 F3-01 = 0 to 7	
	Interface to NC	Apply the zero-speed function.		Multi-function contact output H2-01=1
		Apply the speed agreed function.		Multi-function contact output H2-02=2
		Apply the overtorque detection function. (Cutting loss)		Multi-function contact output H2-03=B or 17
Large constant-output range	Use the winding selection motor.	Option		

Fans and Blowers (Contributes to Energy-saving and Improved Performance)

Example of the Use with Air Scrubber

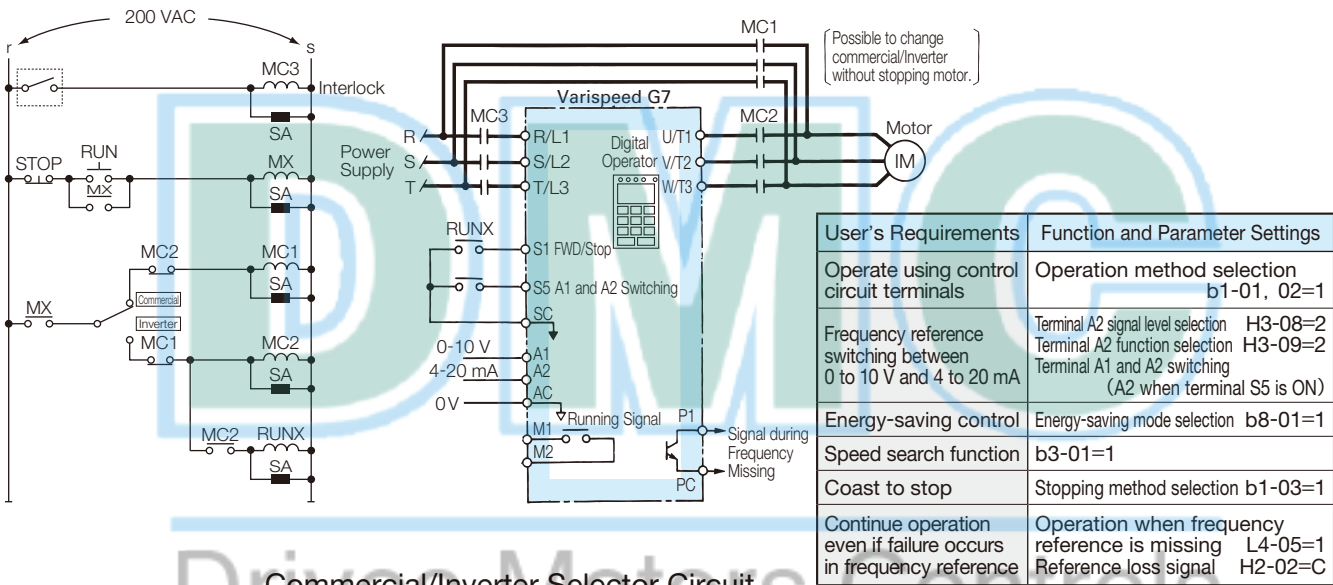
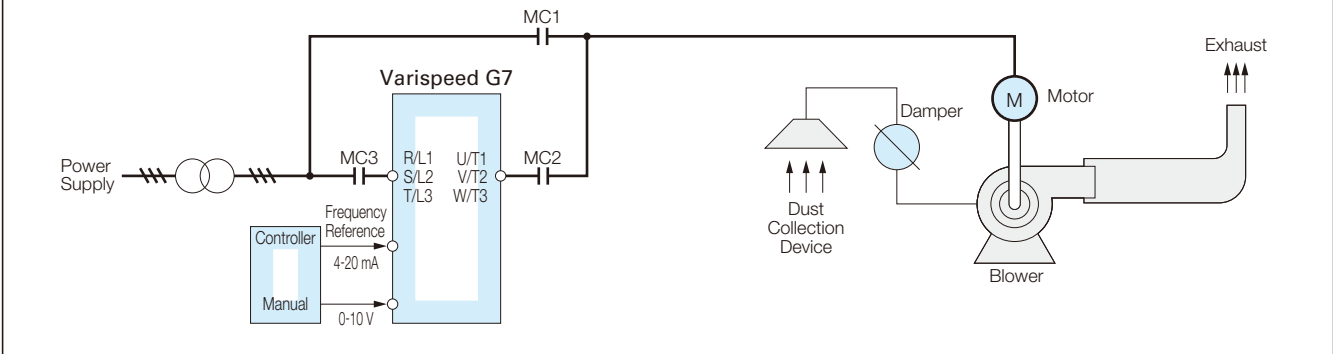

Commercial/Inverter Selector Circuit

Note: In this case, be sure to select coast to stop for Inverter stopping method.

Application Example	User's Requirements	Applicable Varispeed G7 Function	Function and Parameter Settings
Dust Collection System Blower, Fan for Boilers, Fan for Cooling Towers	Switch commercial power supply and Inverter drive without stopping the motor.	Use the speed search operation with speed calculation.	Speed search selection b3-01=1
	Inverter start from coasting stop status without stopping the motor.		
	Save energy since the load is not heavy at low-speed operation.	High-efficiency operation with light load	Energy-saving mode selection b8-01=1
	Avoid overload tripping.	Apply the torque limit function.	Torque limit L7-01=0 to 300%
	Continue operation even when momentary power loss not longer than 2 seconds occur.	Select the momentary power loss reset and restart mode.	Momentary power loss protection L2-01=0 to 2
	Continue operation even if a failure occurs in higher-order frequency reference equipment.	Select the automatic continuous operation mode when frequency reference is missing.	Operating signal selection L4-05=0 to 1 Frequency reference is missing H2-01 to 03=C
	Monitor output power.	Turn the monitor to the output power indication.	Monitor display U1-08
	min ⁻¹ lower limit for lubricating the gear bearing.	Use the frequency reference lower limit.	Frequency reference lower limit d2-02=0 to 110%
	Avoid mechanical resonance. (The resonance point will be passed, and continuous operation is eliminated at this point.)	Use the preset frequency band prohibition function (frequency jump control). Up to 3 frequencies prohibited.	Jump frequency d3-01 to 03=0 to 400 Hz Jump frequency width d3-04=0 to 20.0 Hz
	Wants to prevent machine stop page caused by Inverter tripping.	Use the fault retry function.	Fault retry count L5-01=0 to 10 times

Pumps (Ease of Automatic Control Insures Performance Consistency)

Block Diagram of Feed Water Pump Application

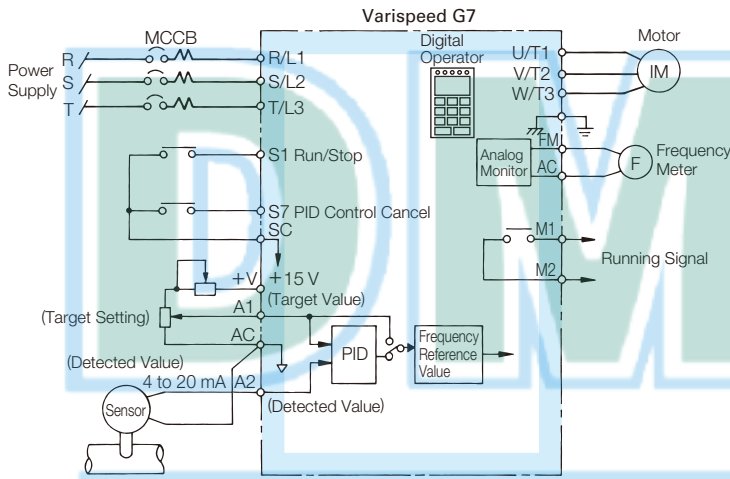
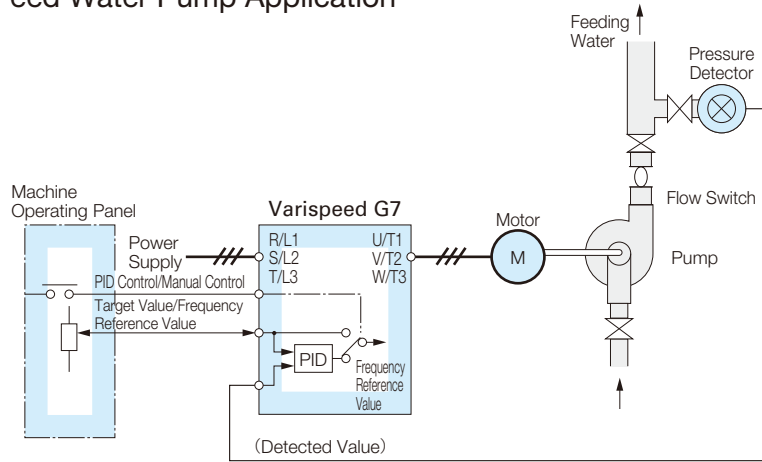

User's Requirements	Function and Parameter Settings
PID control	PID control selection b5-01=1 or 2
PID control characteristics adjustment	PID adjustment b5-02 to 10
	PID control cancel H1-01 to 10=19
Feedback signal 4 to 20 mA	Terminal A2 signal level selection H3-08=2
	Terminal A2 function selection H3-09=B
Meter indication of motor current or output frequency	Analog monitor selection H4-01, 04=1 to 38

Note: Be sure to set the PID feedback signal at terminal A2 or RP.

Application	User's Requirements	Applicable Varispeed G7 Function	Function and Parameter Settings
General Pump	Easy automatic control	Use PID function inside the Inverter. (External PID control is not required.)	PID adjustment b5-01 to 11
Chemical-Feeding Pump	Keep the motor min^{-1} at a certain speed even if there is a load change.	Available with standard function (open loop vector control)	Control method selection A1-02=2
	Keep the mixed water ratio constant.	Use the output (4 to 20 mA) of the flow rate sensor as the feedback signal.	Terminal A2 signal selection H3-08=2 H3-09=B
	Ammeter and frequency meter for monitoring load conditions are required.	Cancel PID control.	Master/Aux. switching PID control enable/disable H1-01 to 10=19
Warm/Cold Water Circulation Pump	Drive the pump directly using 4-20 mA signal.	Use external terminals A2 and AC.	Output selection function H4-01, 04=2, 3
	Function to maintain minimum speed.	Use the lower-limit of the reference frequency.	Run signal selection b1-01, 02=1
	Run the system using the commercial power supply when an emergency occurs, then return to Inverter.	Use a selector circuit together with the speed search function to restart turning motor.	Frequency reference lower limit d2-02=0 to 110%
	Function that can keep the system working without resetting it even when a momentary power loss occurs.	Use the continuous operation function to restart after momentary power loss within two seconds. Use a toggle switch for start and stop.	Speed search function selection b3-01=1 or 3
Discharge Pump	Keep a constant water level inside a tank using a water gauge.	Use signals (4 to 20 mA) sent from the waterlevel adjusting unit as the feedback signal.	Momentary power loss protection L2-01=0 to 2
		Control the water level by PID control.	Terminal A2 signal selection H3-08=2 H3-09=B
	Keep the motor min^{-1} above the minimum because if the min^{-1} is too low, water flows in the reverse direction.	Use the lower-limit of the frequency reference.	PID control b5-01 to 11 setting
		Frequency reference lower limit d2-02=0 to 110%	

Fault Detection

When the Inverter detects a fault, the fault contact output operates, and the Inverter is shut OFF causing the motor to coast to stop. (The stopping method can be selected for some faults, and the selected stopping method will be used with these faults.)

A fault code is displayed on the digital operator.

Use one of following methods to reset after restarting the Inverter.

- Set a multi-function input (H1-01 to H1-10) to 14 (Fault Reset) and turn ON the error reset signal.
- Press the  key on the digital operator.
- Turn OFF the main circuit power supply, make sure that there are no short circuits or incorrect wiring of the control circuit terminals (e.g., +V, -V, and AC), and then turn the power supply ON again.

Fault	Display	Descriptions
Overcurrent (OC)	OC Over Current	The Inverter output current exceeded the overcurrent detection level. (200% of rated current)
Ground Fault (GF)	GF Ground Fault	The ground fault current at the Inverter output exceeded approx. 50% of the rated output current.
Fuse Blown (PUF)	PUF Main IGBT Fuse Blown	The fuse in the main circuit is blown.
Main Circuit Overvoltage (OV)	OV DC Bus Fuse Open	The main circuit DC voltage exceeded the overvoltage detection level. 200 V class: approx. 410 V, 400 V class: approx. 820 V
Main Circuit Undervoltage Main Circuit MC Operation Fault (UV1)	UV1 DC Bus Undervolt	The main circuit DC voltage is below the Undervoltage Detection Level (L2-05). 200 V class: approx. 190 V, 400 V class: approx. 380 V
Control Power Fault (UV2)	UV2 CLT PS Undervolt	The control power supply voltage dropped. A momentary power loss recovery unit is not attached to a 200 V/400 V-class Inverter of 7.5 kW or less and the value of L2-02 factory setting has been changed to the larger value.
Inrush Prevention Circuit Fault (UV3)	UV3 MC Answerback	The MC did not respond for 10 s even though the MC-ON signal has been output. (200 V class: 30 to 110 kW, 400 V class: 55 to 300 kW)
Main Circuit Voltage Fault (PF)	PF Input Pha Loss	An open-phase occurred in the input power supply and the voltage balance between phases is bad. (Detected when L8-05 = 1)
Output Open-phase (LF)	LF Output Pha Loss	An open-phase occurred at the Inverter output. (Detected when L8-07 = 1 or 2)
Cooling Fin Overheating (OH, OH1)	OH(OH1) Heatsink Overtemp	The temperature of the Inverter's cooling fins exceeded the setting in L8-02 or 100 °C. (OH: Exceeded the setting in L8-02 [L8-03 = 0 to 2], OH1: Exceeded 100 °C) Inverter's cooling fan stopped.
Motor Overheating Alarm (OH3)	OH3 Motor Overheat 1	The Inverter will stop or continue to operate according to the setting of L1-03.
Motor Overheating Fault (OH4)	OH4 Motor Overheat 2	The Inverter will stop according to the setting of L1-04.
Mounting Type Braking Resistor Overheating (RH)	RH DynBrk Resistor	The protection function has operated if it has been enabled in L8-01.
Built-in Braking Transistor Fault (RR)	RR DynBrk Transistor	The braking transistor is not operating properly.
Motor Overload (OL1)	OL1 Motor Overloaded	The motor overload protection function has operated based on the internal electronic thermal value.
Inverter Overload (OL2)	OL2 Inv Overloaded	The Inverter overload protection function has operated based on the internal electronic thermal value. The Inverter overload protection function operated based on the internal electronic thermal value during operation at a low speed of 6 Hz or less.
Overtorque Detected 1 (OL3)	OL3 Overtorque Det 1	There has been a current greater than the setting in L6-02 for longer than the time set in L6-03.
Overtorque Detected 2 (OL4)	OL4 Overtorque Det 2	There has been a current greater than the setting in L6-05 for longer than the time set in L6-06.
High-slip Braking OL (OL7)	OL7 HSB-OL	The output frequency did not change for longer than the time set in N3-04.
Undertorque Detected 1 (UL3)	UL3 Undertorq Det 1	There has been a current less than the setting in L6-02 for longer than the time set in L6-03.
Undertorque Detected 2 (UL4)	UL4 Undertorq Det 2	There has been a current less than the setting in L6-05 for longer than the time set in L6-06.
Overspeed (OS)	OS Overspeed Det	The speed has been higher than the setting in F1-08 for longer than the time set in F1-09.
PG Disconnection Detected (PGO)	PGO PG Open	PG pulses were not input when the Inverter was outputting a frequency.
Excessive Speed Deviation (DEV)	DEV Speed Deviation	The speed deviation has been greater than the setting in F1-10 for longer than the time set in F1-11.
Control Fault (CF)	CF Out of Control	The torque limit was reached continuously for 3 seconds or longer during a deceleration stop at open-loop vector control 1. A speed estimation fault is detected at open-loop vector control 2.

Fault	Display	Descriptions
PID Feedback Reference Lost (FbL)	FbL Feedback Loss	A PID feedback reference loss was detected (b5-12 = 2) and the PID feedback input was less than b5-13 (PID feedback loss detection level) for longer than the time set in b5-14 (PID feedback loss detection time).
External Fault Input from Communications Option Card (EF0)	EF0 Opt External Flt	An "external fault" was input from a communications option card.
External Fault (Input Terminal S3) (EF3)	EF3 Ext Fault S3	An "external fault" was input from a multi-function input terminal.
External Fault (Input Terminal S4) (EF4)	EF4 Ext Fault S4	
External Fault (Input Terminal S5) (EF5)	EF5 Ext Fault S5	
External Fault (Input Terminal S6) (EF6)	EF6 Ext Fault S6	
External Fault (Input Terminal S7) (EF7)	EF7 Ext Fault S7	
External Fault (Input Terminal S8) (EF8)	EF8 Ext Fault S8	
External Fault (Input Terminal S9) (EF9)	EF9 Ext Fault S9	
External Fault (Input Terminal S10) (EF10)	EF10 Ext Fault S10	
External Fault (Input Terminal S11) (EF11)	EF11 Ext Fault S11	
External Fault (Input Terminal S12) (EF12)	EF12 Ext Fault S12	
Zero Servo Fault (SVE)	SVE Zero Servo Fault	The rotation position moved during zero servo operation
Digital Operator Connection Fault (OPR)	OPR Oper Disconnect	The connection to the digital operator was broken during operation for a run command from the digital operator.
MEMOBUS Communications Error (CE)	CE Memobus Com Err	A normal reception was not executed for 2 seconds or longer after control data was received once.
Option Communications Error (BUS)	BUS Option Com Err	A communications error was detected during a run command or a frequency reference mode from a communications option card.
Digital Operator Communications Error 1 CPU External RAM Fault (CPF00)	CPF00 CPF	Communications with the digital operator were not established within 5 seconds after the power was turned on. CPU external RAM fault.
Digital Operator Communications Error 2 (CPF01)	CPF01 CPF01	After communications were established, there was a communications error with the digital operator for more than 2 seconds.
Baseblock Circuit Error (CPF02)	CPF02 BB Circuit Err	A control part fault.
EEPROM Error (CPF03)	CPF03 EEPROM Error	
CPU Internal A/D Converter Error (CPF04)	CPF04 Internal A/D Err	
CPU External A/D Converter Error (CPF05)	CPF05 External A/D Err	
Option Card Connection Error (CPF06)	CPF06 Option error	
ASIC Internal RAM Fault (CPF07)	CPF07 RAM-Err	The control circuit is damaged.
Watchdog Timer Fault (CPF08)	CPF08 WAT-Err	
CPU-ASIC Mutual Diagnosis Fault (CPF09)	CPF09 CPU-Err	
ASIC Version Fault (CPF10)	CPF10 ASIC-Err	The control circuit is faulty.
Option Card Error (CPF20)	CPF20 Option A/D error	The option card's A/D converter is faulty.
Communications Option Card Self Diagnosis Error (CPF21)	CPF21 Option CPU down	Communications option card fault.
Communications Option Card Model Code Error (CPF22)	CPF22 Option Type Err	
Communications Option Card DPRAM Error (CPF23)	CPF23 Option DPRAM Err	Communications option card fault. The copy function of the Digital Operator was used during communications.
Main Circuit Capacitor Neutral Point Potential Error (VCF)	VCF Vcn Failure	An excessive imbalance occurred in the main circuit capacitor's neutral point potential.
No display	-	There was a drop in control power voltage.

Alarm Detection

Alarms are detected as a type of Inverter protection function that do not operate the fault contact output. The system will automatically returned to its original status once the cause of the alarm has been removed. The digital operator display blinks and an alarm is sent from the multi-function outputs (H2-01 to H2-05) if selected.

Alarm	Display	Descriptions	
Forward/Reverse Run Commands Input Together (EF)	EF (blinking) External Fault	Both the forward and reverse run commands have been ON for more than 5 seconds.	
Main Circuit Undervoltage (UV)	UV (blinking) DC Bus Undervolt	The following conditions occurred when there was no Run signal. · The main circuit DC voltage was below the undervoltage detection level setting (L2-05). · The inrush current limit contactor opened. · The control power supply voltage was below the CUV level.	
Main circuit Overvoltage (OV)	OV (blinking) DC Bus Overvolt	The main circuit DC voltage exceeded the overvoltage detection level. 200 V class: approx. 410 V, 400 V class: approx. 820 V	
Cooling Fin Overheating (OH)	OH (blinking) Heatsink Overtemp	The temperature of cooling fins exceeded the setting in L8-02. (Factory setting: L8-03=3) Note: Make sure that there are no short circuits or incorrect wiring of the control circuit terminals +V, -V, and AC.	
Inverter Overheating Pre-alarm (OH2)	OH2 (blinking) Over Heat 2	An OH2 alarm signal (Inverter overheating alarm signal) was input from a multi-function input terminal (S3 to S12).	
Motor Overheating (OH3)	OH3 (blinking) Motor Overheat 1	E was set in H3-09 and the motor temperature thermistor input exceeded the alarm detection level.	
Overtorque 1 (OL3)	OL3 (blinking) Overtorque Det 1	There has been a current greater than the setting in L6-02 for longer than the time set in L6-03.	
Overtorque 2 (OL4)	OL4 (blinking) Overtorque Det 2	There has been a current greater than the setting in L6-05 for longer than the time set in L6-06.	
Undertorque 1 (UL3)	UL3 (blinking) Undertorq Det 1	There has been a current less than the setting in L6-02 for longer than the time set in L6-03.	
Undertorque 2 (UL4)	UL3 (blinking) Undertorq Det 2	There has been a current less than the setting in L6-05 for longer than the time set in L6-06.	
Overspeed (OS)	OS (blinking) Overspeed Det	The speed has been greater than the setting in F1-08 for longer than the time set in F1-09.	
PG Disconnected (PGO)	PGO (blinking) PG Open	PG pulses were not input when the Inverter was outputting a frequency.	
Excessive Speed Deviation (DEV)	DEV (blinking) Speed Deviation	The speed deviation has been greater than the setting in F1-10 for longer the time set in F1-11.	
External Fault (Input Terminal S3) (EF3)	EF3 (blinking) Ext Fault S3	An "external fault" was input from a multi-function input terminal.	
External Fault (Input Terminal S4) (EF4)	EF4 (blinking) Ext Fault S4		
External Fault (Input Terminal S5) (EF5)	EF5 (blinking) Ext Fault S5		
External Fault (Input Terminal S6) (EF6)	EF6 (blinking) Ext Fault S6		
External Fault (Input Terminal S7) (EF7)	EF7 (blinking) Ext Fault S7		
External Fault (Input Terminal S8) (EF8)	EF8 (blinking) Ext Fault S8		
External Fault (Input Terminal S9) (EF9)	EF9 (blinking) Ext Fault S9		
External Fault (Input Terminal S10) (EF10)	EF10 (blinking) Ext Fault S10		
External Fault (Input Terminal S11) (EF11)	EF11 (blinking) Ext Fault S11		
External Fault (Input Terminal S12) (EF12)	EF12 (blinking) Ext Fault S12		
PID Feedback Reference Lost (FbL)	FBL (blinking) Feedback Loss		A PID feedback reference loss was detected (b5-12 = 2) and the PID feedback input was less than b5-13 (PID feedback loss detection level) for longer than the time set in b5-14 (PID feedback loss detection time).
MEMOBUS Communications Error (CE)	CE (blinking) MEMOBUS Com Err		A normal reception was not possible for 2 seconds or longer after control data was received once.
Option Card Communications Error (BUS)	BUS (blinking) Option Com Err	A communications error was detected during a run command or a frequency reference mode from a communications option card.	
Communications on Standby (CALL)	CALL (blinking) Com Call	Data was not received properly when the power supply was turned on.	
Current Alarm * (HCA)	HCA (blinking) High Current Alarm	The output current has exceeded the overcurrent alarm level (over 150% of the rated current).	
Cooling Fan Maintenance Timer * (LT-F)	LT-F (blinking) Fan Maintenance	Monitor U1-63 has reached 100%.	
Electrolytic Capacitor Maintenance Timer * (LT-C)	LT-C (blinking) C Maintenance	Monitor U1-61 has reached 100%.	

Operation Errors

An operation error will occur if there is an invalid setting or a contradiction between two constant settings. The Inverter will not start until the constants have been set correctly. (The alarm output and fault contact outputs will not operate either.)

Error	Display	Descriptions
Incorrect Inverter Capacity Setting (OPE01)	OPE01 kVA Selection	The Inverter capacity setting doesn't match the unit. (Contact your Yaskawa representative.)
Constant Setting Range Error (OPE02)	OPE02 Limit	The constant setting is out of the valid setting range.
Multi-function Input Selection Error (OPE03)	OPE03 Terminal	The same setting has been selected for two or more multi-function inputs (H1-01 to 05) or UP or DOWN command was selected independently, etc.
Option Card Reference Selection Error (OPE05)	OPE05 Sequence Select	An option card is not connected when the option card was selected as the frequency reference source by setting b1-01 to 3.
Control Mode Selection Error (OPE06)	OPE06 PG Opt Missing	A PG speed control card is not connected when V/f control with PG was selected by setting A1-02 to 1.
Multi-function Analog Input Selection Error (OPE07)	OPE07 Analog Selection	The same setting has been selected for the analog input selection and the PID function selection.
Constant Selection Error (OPE08)	OPE08	A setting not required in the control mode has been selected.
PID Control Selection Error (OPE09)	OPE09	PID sleep function is valid (b5-01 ≠ 0 and b5-15 ≠ 0) and stop method has been set to 2 or 3.
V/f Data Setting Error (OPE10)	OPE10 V/f Ptrn Setting	Constants E1-04, E1-06, E1-07, and E1-09 do not satisfy the conditions.
Constant Setting Error (OPE11)	OPE11 Carr Freq/On-Delay	Constant setting error occurred.
EEPROM Write Error (ERR)	ERR EEPROM R/W Err	A verification error occurred when writing EEPROM.

Drives Motors Controls

Typical Connection Diagrams

With Transistor at 0 V Common/Sink Mode

When input signal is a sequence connection (0 V common/sink mode) by NPN transistor using +24 V internal power supply, set CN5 (shunt connector) on the control board to NPN.

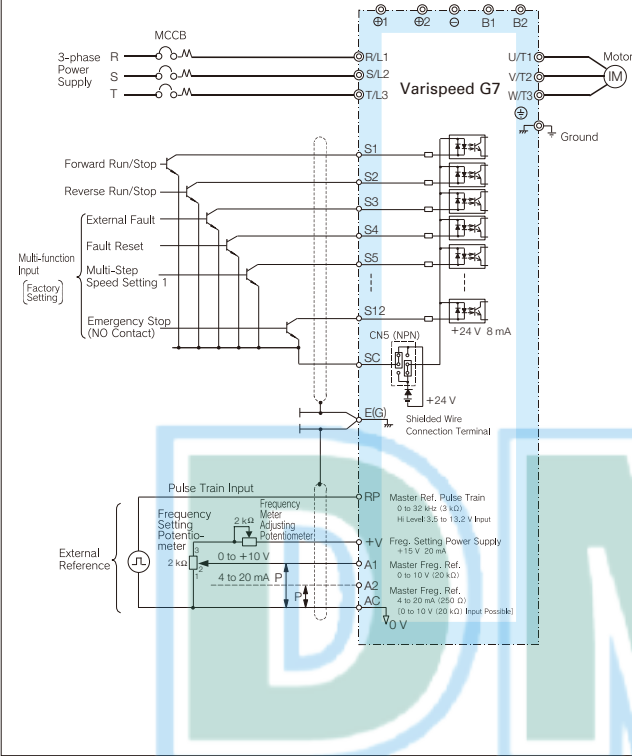

With Transistor at +24 V Common/Source Mode

When input signal is a sequence connection (+24 V common/source mode) by PNP transistor using +24 V internal power supply, set CN5 (shunt connector) on the control board to PNP.

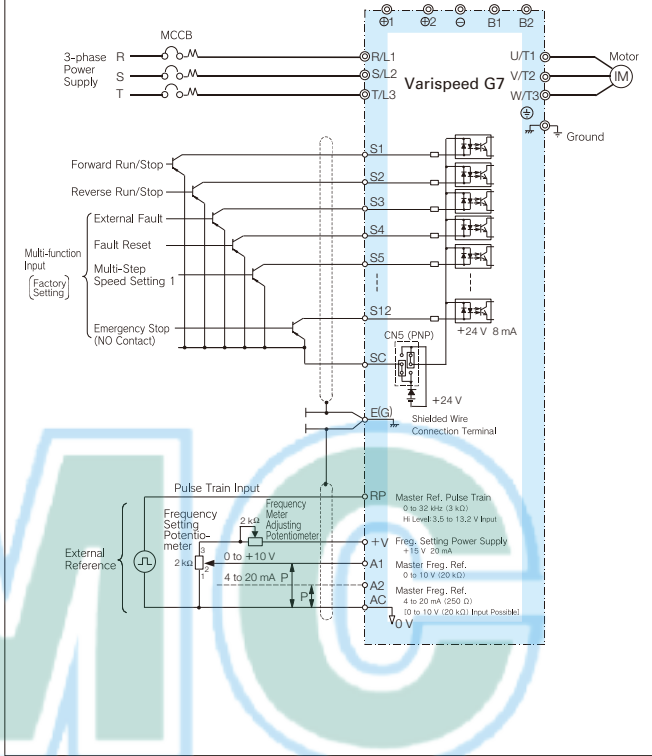

With Transistor at 0 V Common/Sink Mode from External Power Supply

When input signal is a sequence connection (0 V common/sink mode) by NPN transistor using +24 V external power supply, set CN5 (shunt connector) on the control board to EXT.

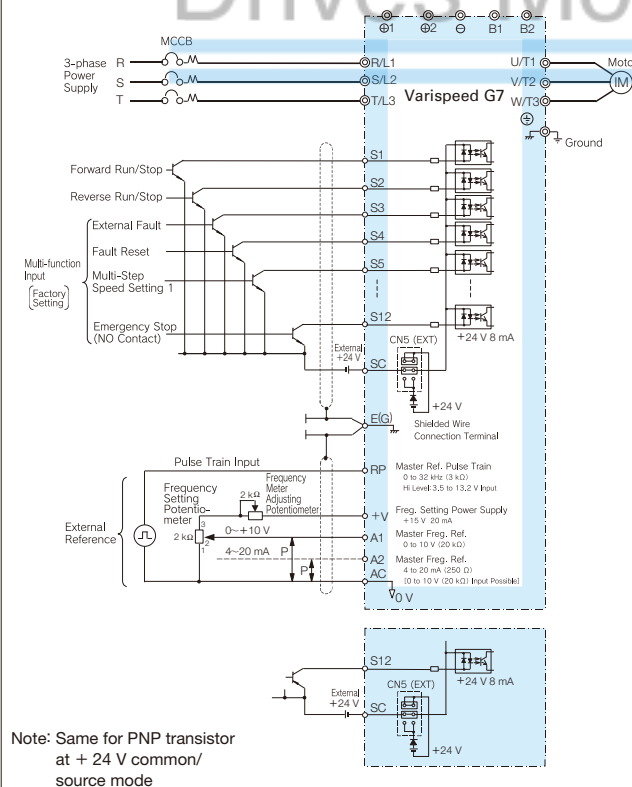

Note: Same for PNP transistor at +24 V common/source mode

With Contact Output, Open Collector Output

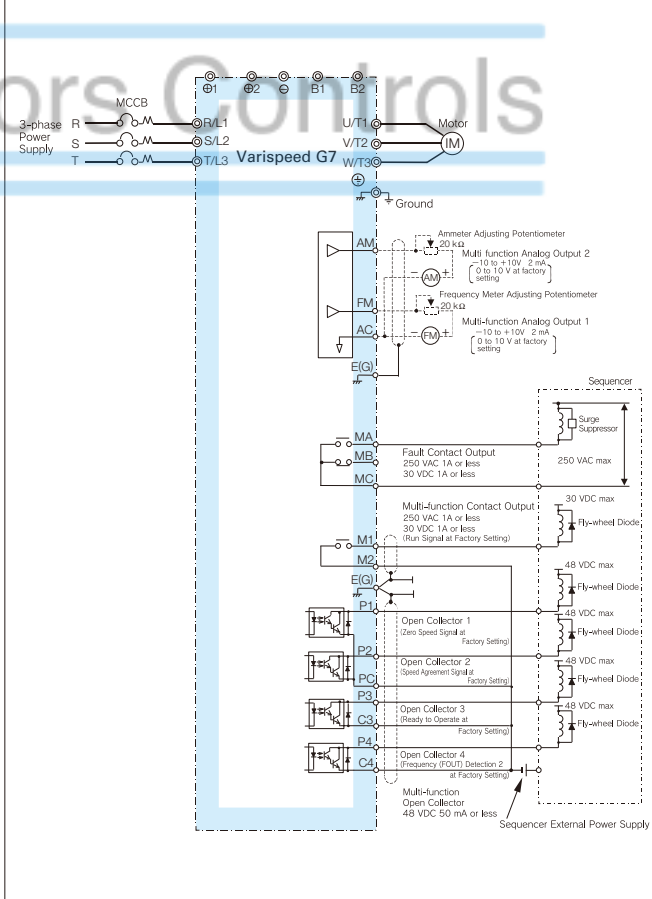

VS Operator Models JVOP-95 and JVOP-96

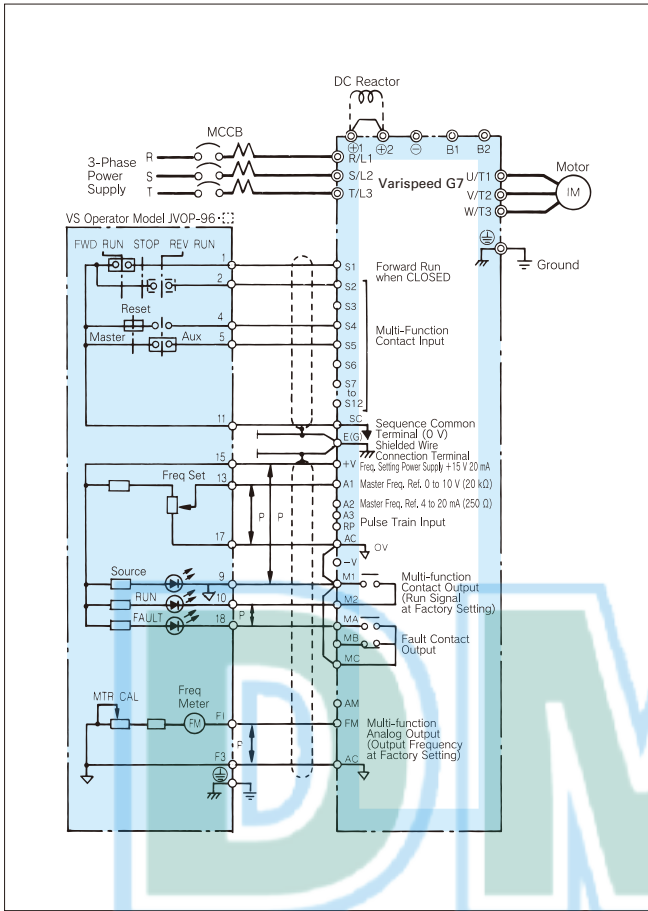

12-pulse Input (3-wire Transformer) Wiring Example

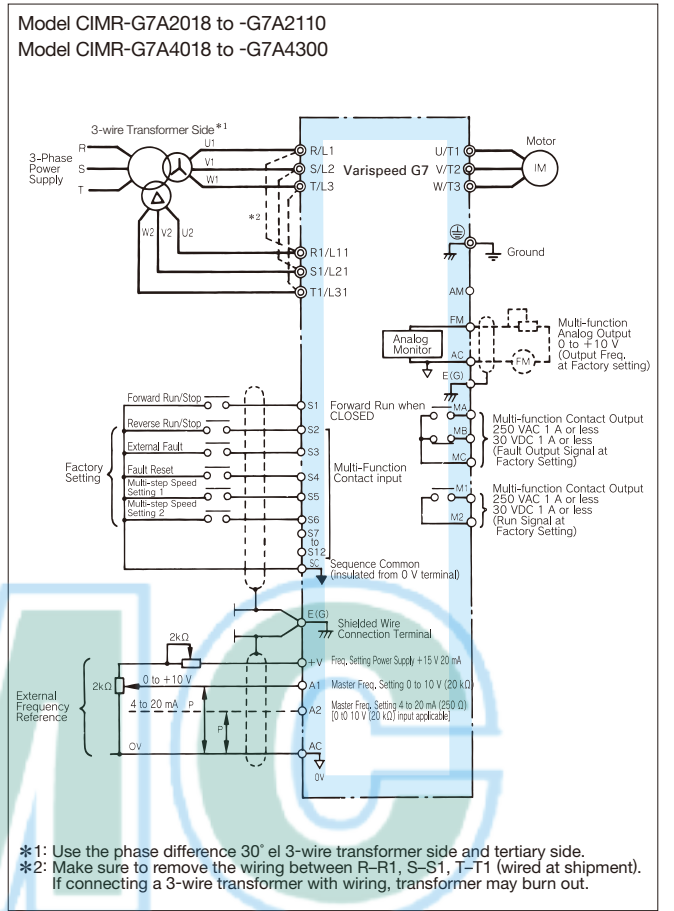

RUN/STOP by MC for Main Circuit Power Line

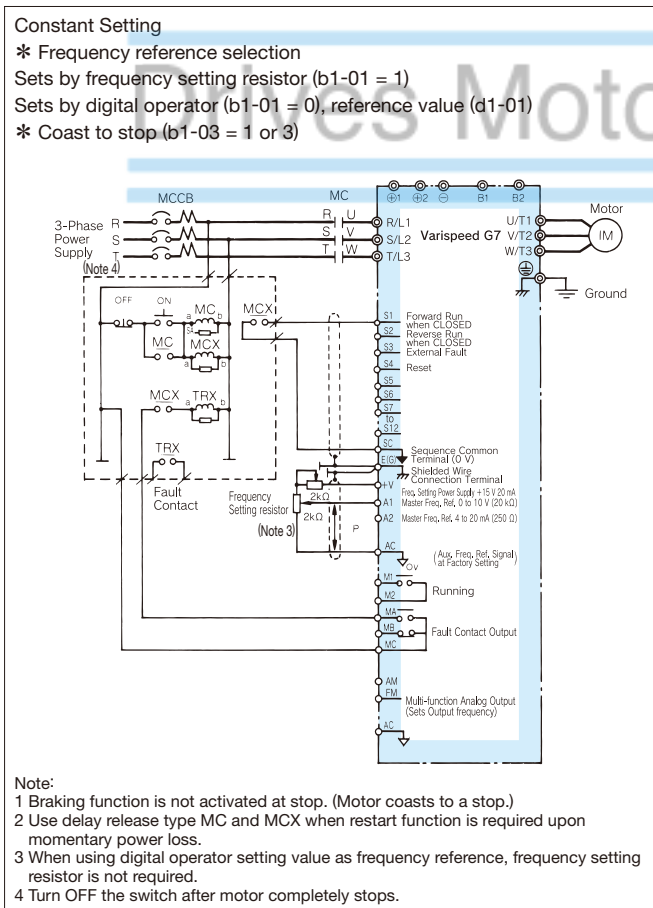

Isolator Connected (4 to 20 mA Received, 4 to 20 mA Output)

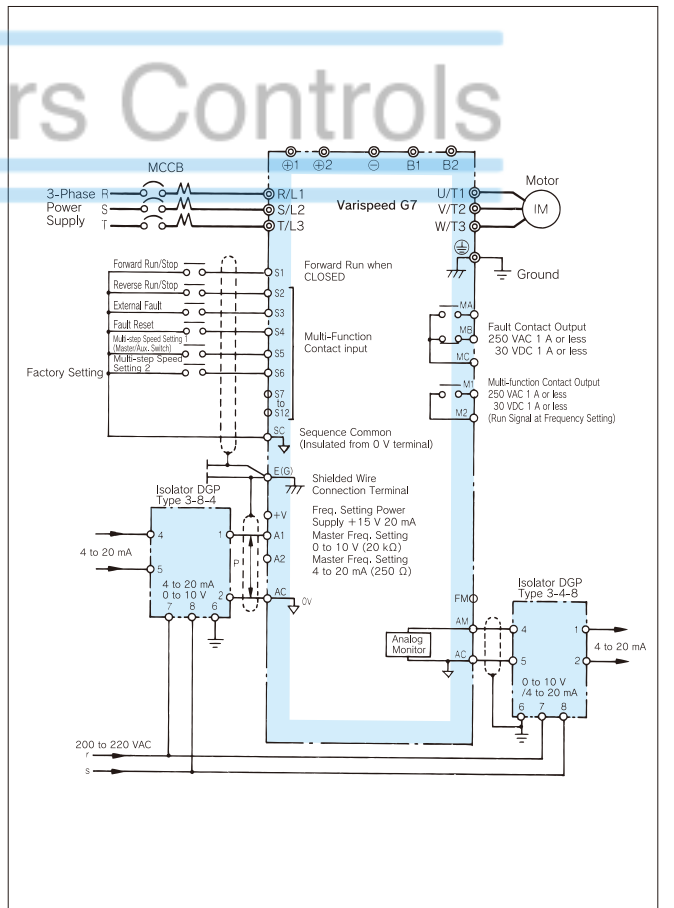

Typical Connection Diagrams

Main Circuit Configuration

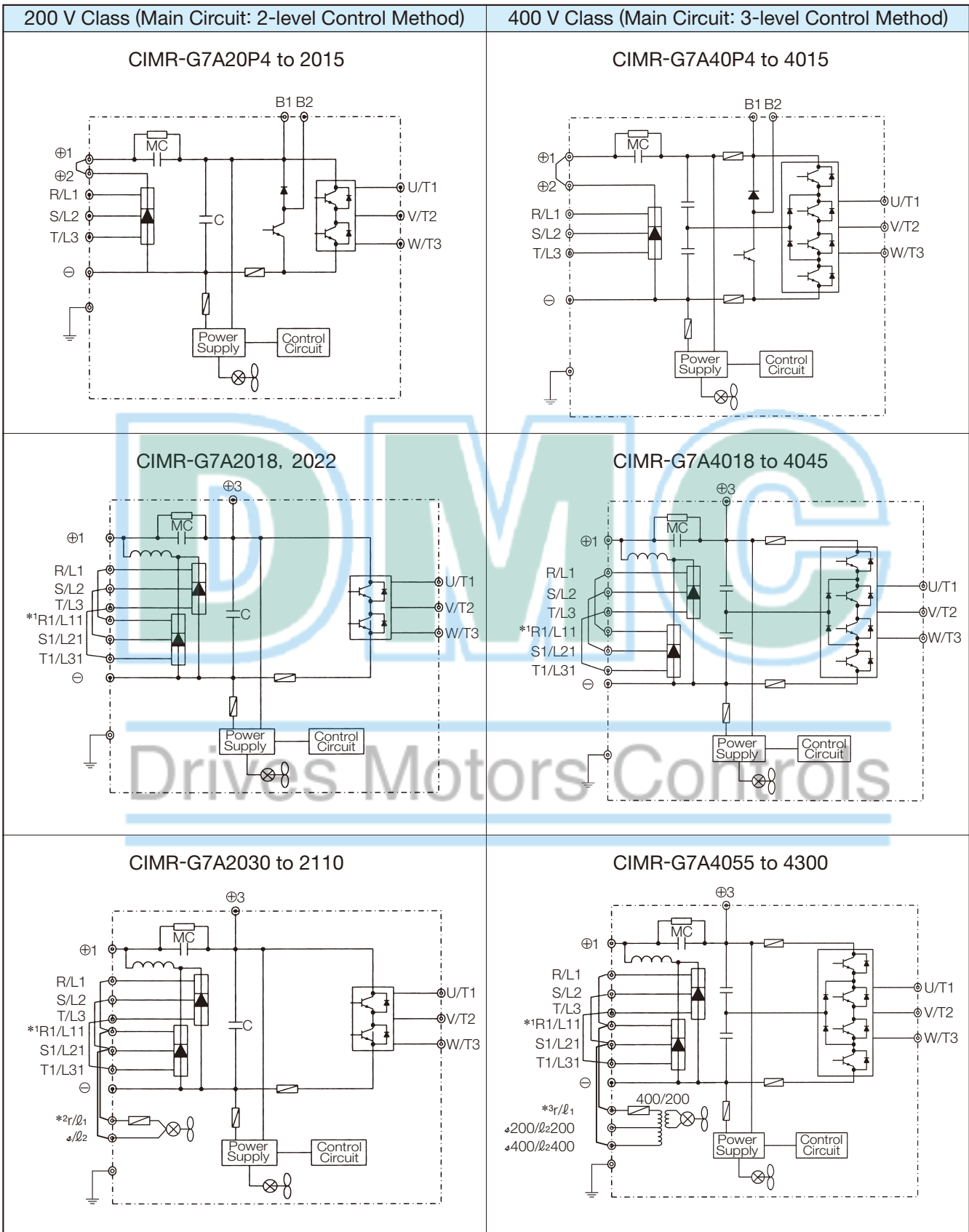

*1: When using 12-pulse input, contact your Yaskawa representative.

*2: $r/l_1 - R$ and $s/l_2 - S$ are short circuited at shipment. When using a DC power supply for the main circuit of models CIMR-G7A2030 to G7A2110 or using a separate power supply for cooling fin and MC operator, remove the wiring for the short circuits and input 200 V power supply to r/l_1 and s/l_2 . For 230 V 50 Hz or 240 V 50/60 Hz power supply, a transformer for cooling fin and MC are required.

*3: $r/l_1 - R$ and $400/l_2 400 - S$ are short circuited at shipment. When using a DC power supply for the main circuit of models CIMR-G7A4055 to G7A4300 or using a separate power supply for cooling fin and MC operator, remove the wiring for the short circuits and input power supply to r/l_1 and $400/l_2 400$ or r/l_1 and $200/l_2 200$.

Options, Peripheral Devices

Objective	Name	Model (Code number)	Details
To protect Inverter wiring	Ground Fault Interrupter (GFI)	Recommended: NV series	Always install a GFI on the power-supply side to protect the power supply system and to prevent an overload at the occurrence of shortcircuit, and to protect the drive from ground faults that could result in electric shock or fire. Note: When a GFI is installed for the upper power supply system, an MCCB can be used instead of a GFI. Choose a GFI designed to minimize harmonics specifically for AC drives. Use one GFI per drive, each with a current rating of at least 30 mA.
	Circuit Breaker	Recommended: NF series	Always install a circuit breaker on the power-supply side to protect the power supply system and to prevent an overload at the occurrence of a short-circuit.
To prevent burning (with braking resistor)	Magnetic contactor	SC series	When braking resistor is attached, install the contactor to prevent the braking resistor from burning. Also inset a surge suppressor on the coil.
To prevent open/close surge to the exterior	Surge suppressor	DCR2-□□□	Absorbs the open / close surge of electro-magnetic contactors and control relays. Always insert the surge suppressor on magnetic contactors and relays near the Inverter.
To isolate input/output signal	Isolator	DGP-□□□	Isolates the Inverter input / output signal, and is effective to prevent inductive noise.
To improve the Inverter input rate	DC reactor AC reactor	UZDA-□□□□ UZBA-□□□□	Applied to improve the input power ratio of the Inverter. The Varispeed G7 incorporates DC reactor on model of 18.5 kW or more (option for model 15 kW or less). When using large power supply capacity (600 kVA or more), also install the DC reactor or AC reactor.
To reduce effect of noise interference to radios and control devices	Input noise filter	Three-phase LNF□-□□□□ FN-□□□□	Reduces noise circulating to the Inverter input power system, or originating from the wiring. Insert the filter as near the Inverter as possible.
	FINEMET zero-phase reactor to reduce radio noise	F6045GB (FIL001098) F11080GB (FIL001097) F200160PB (300-001-041)	Reduces noise from the line that sneaks into the Inverter input power system. Insert as close to the Inverter as possible. Can be used on both the input side and output side.
	Output noise filter	LF-□□□□	Reduces noise originating from the output side wiring of the Inverter. Insert the filter as near the Inverter as possible.
To protect internal circuitry in the event of component failure.	Fuse / Fuse Holder	CR2LS series CR6L series CM, CMS series	Protects internal circuitry in the event of component failure. Fuse should be connected to the input terminal of the drive. Note: Refer to the instruction manual for information on UL approval.
To stop the machine within the preset time	Braking resistor	ERF-150WJ-□□□□	Shortens the deceleration time by consuming the regenerative energy of the motor by the resistor. (Use rate 3% ED)
	Braking resistor unit	LKEB-□□□	Shortens the deceleration time by consuming the regenerative energy of the motor by the resistor. (Use rate 10% ED)
	Braking unit	CDBR-□□□	Used in combination with the braking resistor unit to reduce the deceleration time of the motor.
To supply power to the Inverter main circuits and control circuits from separate power supplies	Separate power supply for the control circuit	PS-U2 PS-U4	To supply power to the Inverter main circuits and control circuits from separate power supplies. Note: A special Inverter that supports a separate power supply unit is required. Contact your Yaskawa representative for details.
To operate the Inverter by external control	VS operator (Small plastic)	JVOP-95-□□□	Control panel that allows remote (50 m max.) frequency setting and start/stop operation by analog reference. Frequency meter scale: 60/120 Hz, 90/180 Hz
	VS operator (Standard sheet metal)	JVOP-96-□□□	Control panel that allows remote (50 m max.) frequency setting and start/stop operation by analog reference. Frequency meter scale: 75 Hz, 150 Hz, 220 Hz
To operate the Inverter by system control	VS system module	JGSM-□□□	System controller that allows optimum system integration by combining with the necessary VS system module according to the automatic control system.
To secure Inverter momentary power loss recovery time	Momentary power loss recovery unit	P0010 Type (200 V class) P0020 Type (400 V class)	For momentary power loss of the control power supply (Power holding time : 2 sec.)
Monitor frequencies, currents, and voltages	Frequency meter, ammeter	DCF-6A	Monitors frequencies and currents.
	Output voltmeter	SCF-12NH	Measures the output voltage externally and designed for use with PWM Inverters.
Adjust frequency reference input, frequency meter, ammeter scales	Potentiometer for frequency reference (2 kΩ)	(ETX3270)	Connected to the control circuit terminals to adjust frequency references and the scales on the meters.
	Potentiometer for scale adjustment (20 kΩ)	(ETX3120)	
	Frequency setting potentiometer (2 kΩ)	RV30YN20S 2 kΩ (RH000739)	Adjusts frequency references and the scale on the meters.
	Frequency meter adjusting potentiometer (20 kΩ)	RV30YN20S 20 kΩ (RH000850)	
	Frequency setting knob	CM-3S	

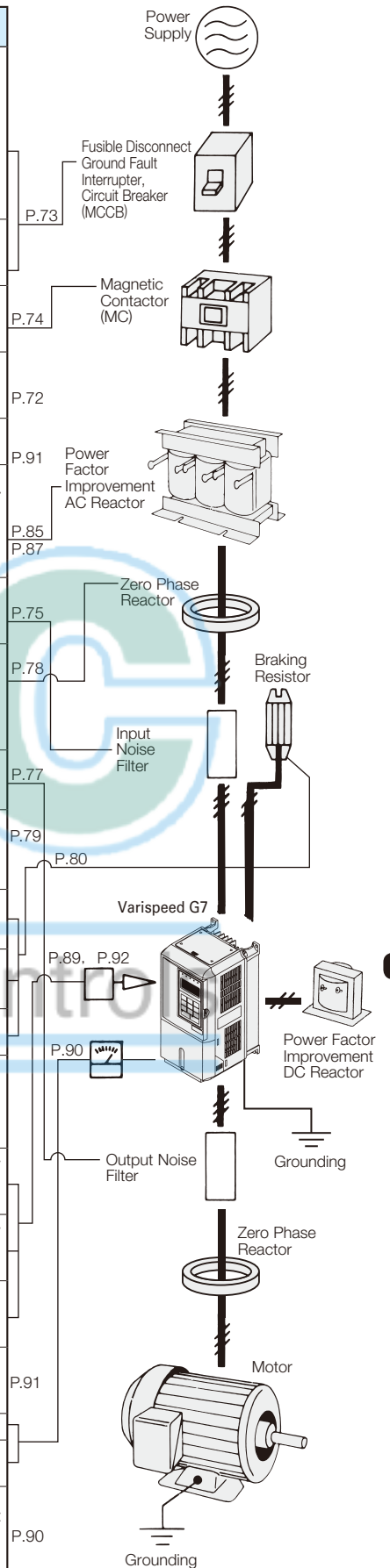

Option Cards

Type	Name	Model	Function	Manual No.
Speed (frequency) reference card	Analog reference card AI-14U	AI-14U	Allows high precision, high resolution analog speed reference setting. · Input signal level: 0 to + 10 VDC (20 kΩ) 1 channel 4 to 20 mADC (250 Ω) 1 channel · Input resolution: 14 bits (1/16384)	TOE- C736-30.13
	Analog reference card AI-14B <small>RoHS Compliant</small>	AI-14B	Allows bipolar high precision, high resolution analog speed reference setting. · Input signal level: 0 to ± 10 VDC (20 kΩ) 1 channel 4 to 20 mADC (500 Ω) 3 channels · Input resolution: 13 bits + code (1/8192)	TOBP C73060015
	Digital reference card DI-08 <small>RoHS Compliant</small>	DI-08	Allows 8-bit digital speed reference setting. · Input signal: Binary 8 bits/BCD 2 digits + SIGN signal + SET signal · Input voltage: + 24 V (isolated) · Input current: 8 mA	TOBP C73060030
	Digital reference card DI-16H2 <small>RoHS Compliant</small>	DI-16H2	Allows 16-bit digital speed reference setting. · Input signal: Binary 16 bits/BCD 4 digits + SIGN signal + SET signal · Input voltage: + 24 V (isolated) · Input current: 8 mA With 16-bit/12-bit select function	TOBP C73060031
Communications option card	MECHATROLINK-II communications I/F card SI-T	SI-T	Used for running or stopping the Inverter, setting or referencing parameters, and monitoring output frequency, output current, or similar items through MECHATROLINK-II communication with the host controller.	SIBP C73060008 TOBP C73060008
	DeviceNet communications I/F card SI-N1*1	SI-N1	Used for running or stopping the Inverter, setting or referencing parameters, and monitoring output frequency, output current, or similar items through DeviceNet communication with the host controller.	SIBP C73060001
	CC-Link communications I/F card SI-C	SI-C	Used for running or stopping the Inverter, setting or referencing parameters, and monitoring output frequency, output current, or similar items through CC-Link communication with the host controller.	TOB- C736-70.6 SIBP C73060014
	Profibus-DP communications I/F card SI-P1*1	SI-P1	Used for running or stopping the Inverter, setting or referencing parameters, and monitoring output frequency, output current, or similar items through Profibus-DP communication with the host controller.	SIBZ- C736-70.9 TOBP C73060011
	LONWORKS communications I/F card SI-J*1	SI-J	Used for HVAC control, running or stopping the Inverter, setting or referencing parameters, and monitoring output current, watt-hours, or similar items through LONWORKS communications with the host controller.	SIBP C73060007
	LONWORKS communications I/F card with DDC function SI-W1*1	SI-W1	Used for HVAC control, running or stopping the Inverter, setting or referencing parameters, and monitoring output current, watt-hours, or similar items through LONWORKS communications with the host controller with Display Data Channel (DDC) function.	SIBP C73060006
	CANopen communications I/F card SI-S1	SI-S1	Used for running or stopping the Inverter, setting or referencing parameters, and monitoring output frequency, output current, or similar items through CANopen communication with the host controller.	—
Monitor option card	Analog monitor card AO-08	AO-08	Outputs analog signal for monitoring Inverter output state (output freq., output current etc.) after absolute value conversion. · Output resolution: 8 bits (1/256) · Output voltage: 0 to + 10 V (non isolated) · Output channel: 2 channels	TOE- C736-30.21
	Analog monitor card AO-12 <small>RoHS Compliant</small>	AO-12	Outputs analog signal for monitoring Inverter output state (output freq., output current etc.) · Output resolution: 11 bits (1/2048) + code · Output voltage: - 10 to + 10 V (non isolated) · Output channel: 2 channels	TOBP C73060026
	Digital output card DO-08	DO-08	Outputs isolated type digital signal for monitoring Inverter run state (alarm signal, zero speed detection etc.) . Output channel: Photo coupler 6 channels (48 V, 50 mA or less) Relay contact output 2 channels (250 VAC, 1 A or less) (30 VDC, 1 A or less)	TOE- C736-30.24
	2C-relay output card DO-02C	DO-02C	· Two multi-function contact outputs (2C-relay) can be used other than those of the Inverter proper unit.	TOE- C736-40.8
PG speed controller card*2	PG-A2	PG-A2	Pulse generator on motor performs speed feedback to correct speed fluctuations caused by slipping (for V/f control with PG). · Phase A pulse (single pulse) inputs (voltage, complementary, open collector input) · Maximum input frequency: 32767 Hz · Pulse monitor output: + 12 V, 20 mA (Power supply output for PG: + 12 V, max. current 200 mA)	TOE- C736-40.1
	PG-B2 <small>RoHS Compliant</small>	PG-B2	Used for vector control with PG or V/f control with PG · Phase A and B pulse inputs (complementary input) · Maximum input frequency: 32767 Hz · Pulse monitor output: Open collector, + 24 V, Max. current 30 mA (Power supply output for PG: + 12 V, Max. current 200 mA)	TOBP C73060009

Type	Name	Model	Function	Manual No.
Built-in type (connected to connector) PG speed controller*2	PG-D2	PG-D2	Used for V/f control with PG <ul style="list-style-type: none"> Phase A pulse (differential pulse) input for V/f control (RS-422 input) Maximum input frequency: 300 kHz Pulse monitor output: RS-422 (Power supply output for PG: +5 V or +12 V, Max. current 200 mA)	TOE-C736-40.3
	PG-X2	PG-X2	Used for vector control with PG or V/f control with PG <ul style="list-style-type: none"> Phase A, B and Z pulse (differential pulse) inputs (RS-422 input) Maximum input frequency: 300 kHz Pulse monitor output: RS-422 (Power supply output for PG: +5 V or +12 V, Max. current 200 mA)	TOBP-C73060010

*1: When using configuration software installed in an Inverter on various field networks, a file is required to connect the software to the Inverter.

Contact your Yaskawa representative for the appropriate file.

*2: PG speed controller card is required for PG control.

Built-in Type Option Card and Wiring Schematic

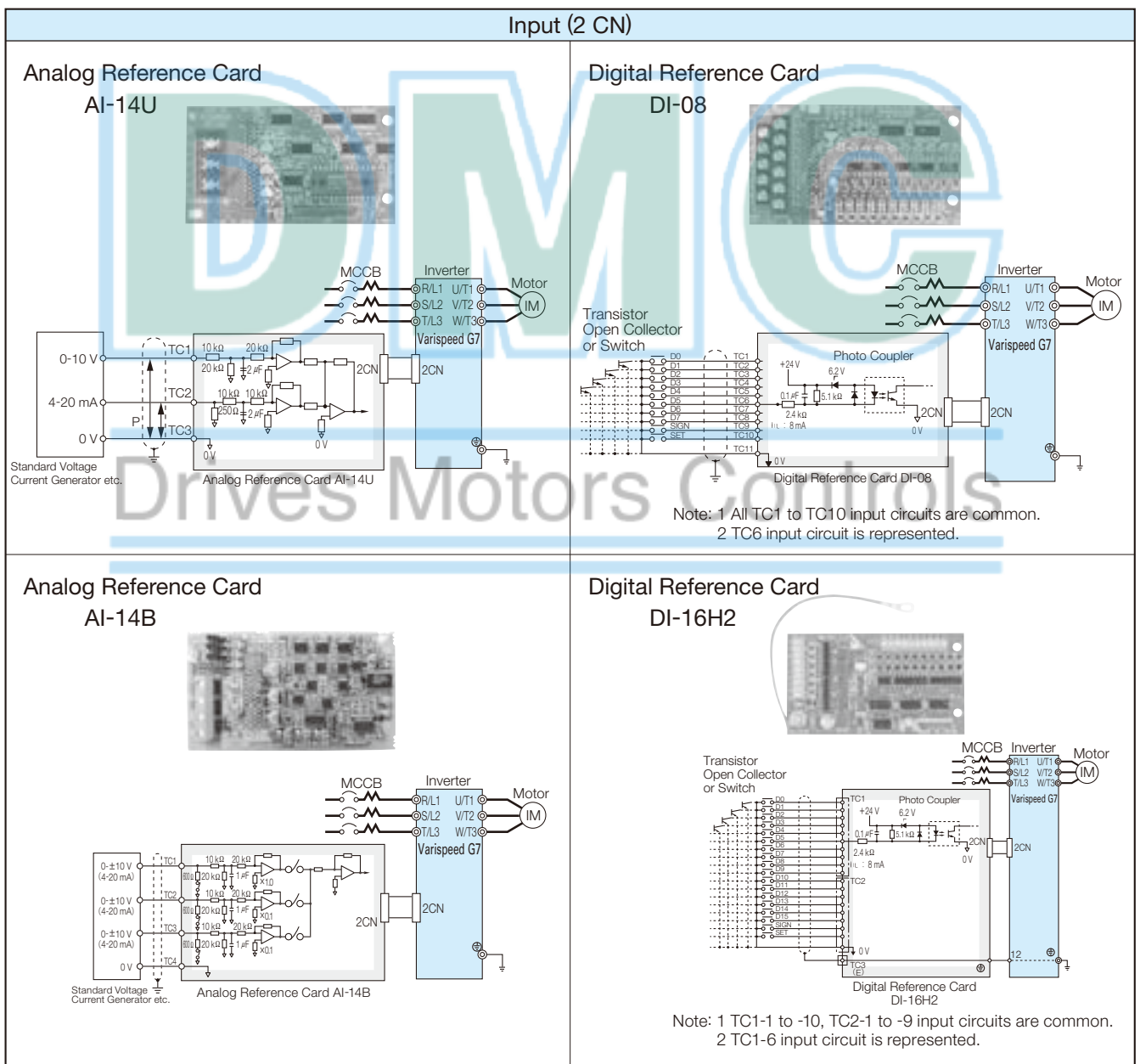

Input (2 CN)

MECHATROLINK-II Communications I/F Card
SI-T



Note: If using the SI-T card, an optional card for monitoring cannot be installed in the Inverter.

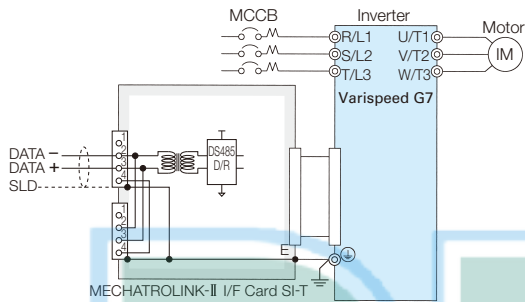

Profibus-DP Communications I/F Card
SI-P1

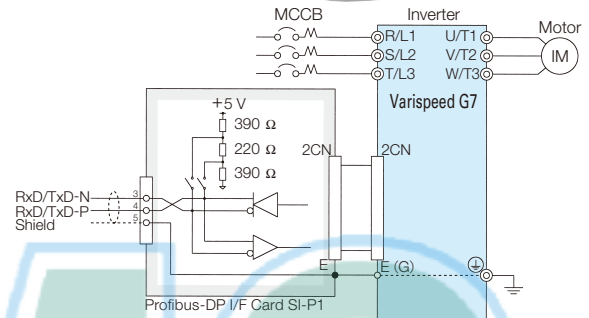
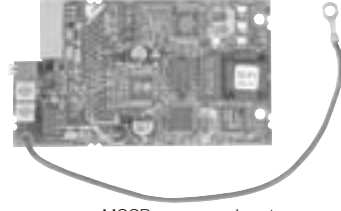

DeviceNet Communications I/F Card
SI-N1

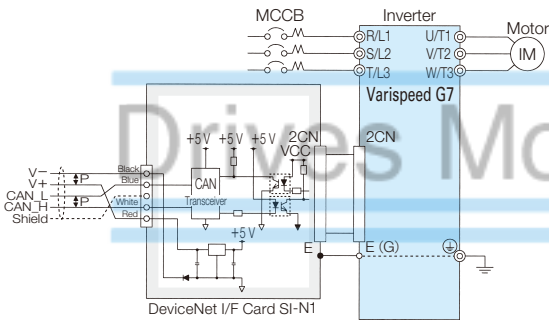
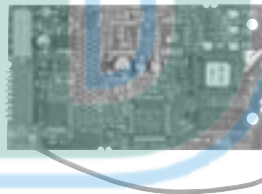

LONWORKS Communications I/F Card
SI-J SI-W1 (with DDC function)

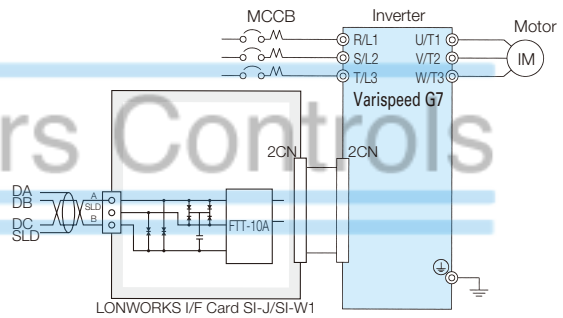

CC-Link Communications I/F Card
SI-C

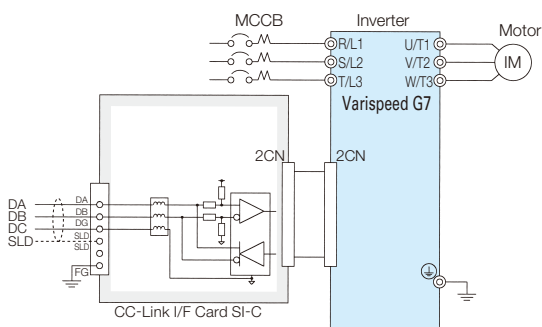

CANopen Communications I/F Card
SI-S1

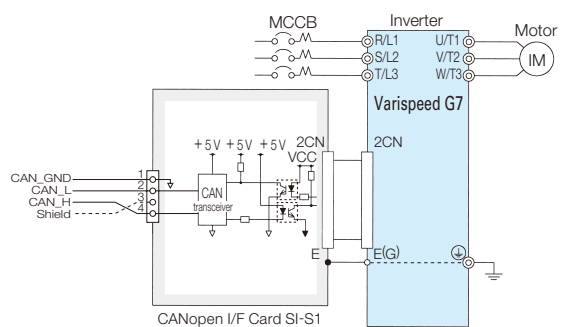
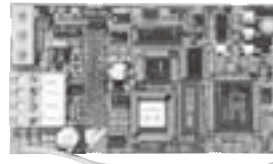

Output (3 CN)

Analog Monitor Card
AO-08

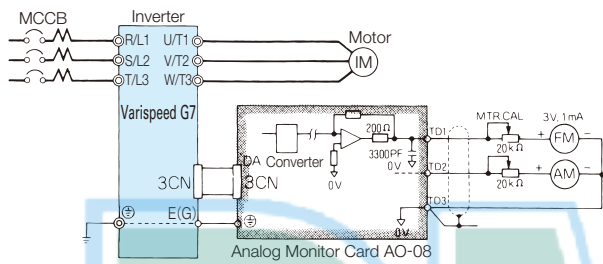
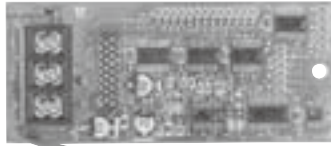

Digital Output Card
DO-08

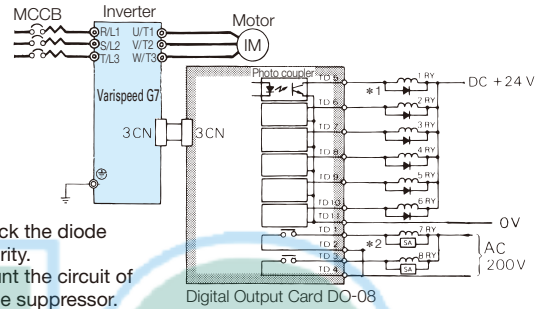
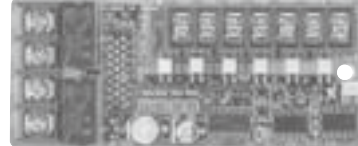

- *1: Check the diode polarity.
- *2: Mount the circuit of surge suppressor.

Analog Monitor Card
AO-12

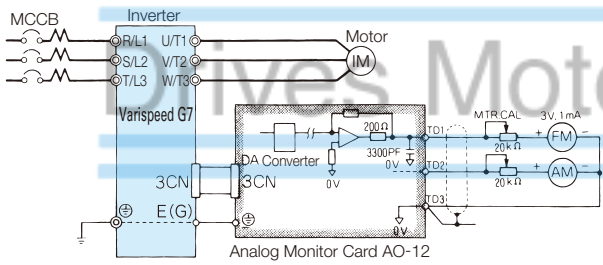
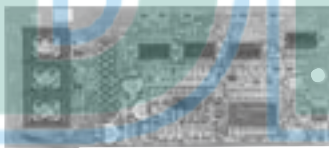

Digital Output Card
DO-02C

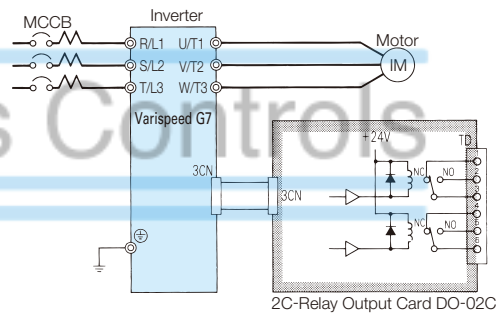
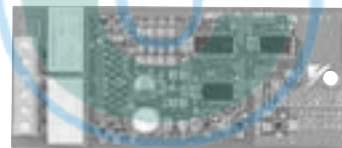

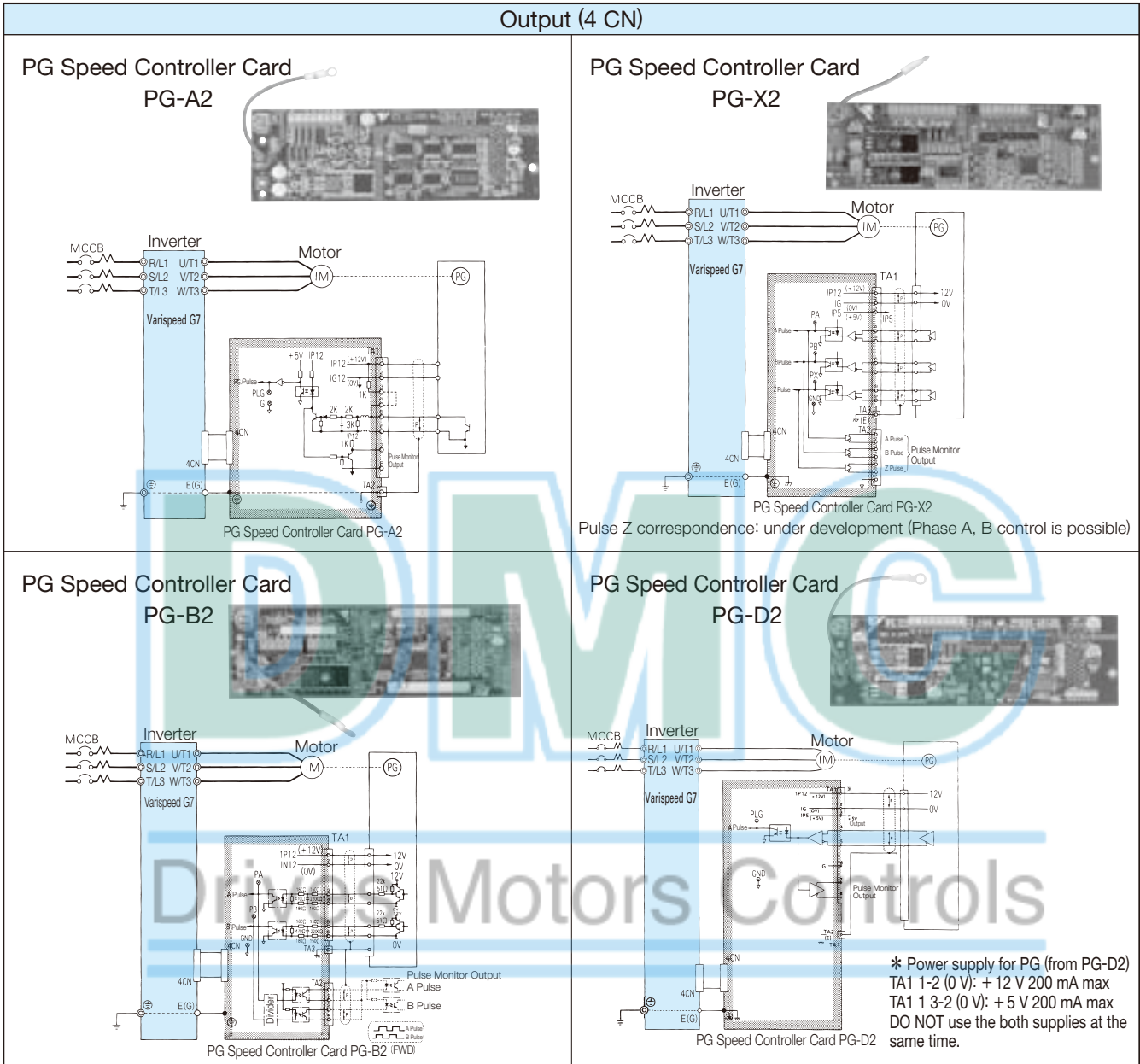

Surge Suppressor (Manufactured by NIPPON CHEMI-CON CORPORATION)

Surge suppressors used for coils in electromagnetic contactors, control relays, electromagnetic valves, and electromagnetic brakes used as the Varispeed G7 peripheral units.

Coils of Magnetic Contactor and Control Relay		Surge Suppressor		
		Model	Specifications	Code No.
200 V to 230 V	Large-size Magnetic Contactors	DCR2-50A22E	220 VAC 0.5 μ F+200 Ω	C002417
200 V to 240 V	Control Relay MY2*1, MY3*1 MM2*1, MM4*1 HH22*2, HH23*2	DCR2-10A25C	250 VAC 0.1 μ F+100 Ω	C002482
380 to 480 V		RFN3AL504KD	1000 VDC 0.5 μ F+220 Ω	C002630

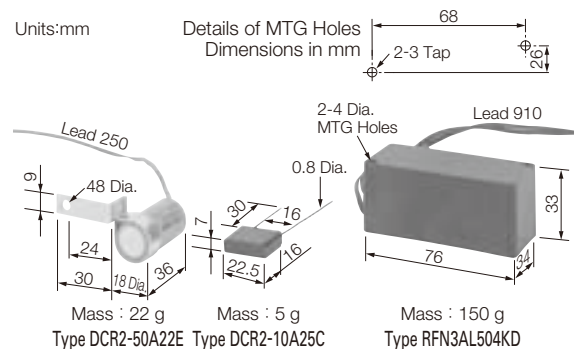

*1: Manufactured by Omron Corporation.
*2: Manufactured by Fuji Electric FA Components & Systems Co., Ltd.

Ground Fault Interrupter (GFI), Circuit Breaker (MCCB)

Be sure to connect an MCCB or ground fault interrupter between the power supply and Varispeed G7 input terminals R, S, T.



Ground Fault Interrupter (GFI)
[Mitsubishi Electric Corporation]



Circuit Breaker
[Mitsubishi Electric Corporation]

200 V Class

Motor Capacity (kW)	Ground Fault Interrupter (GFI)						Circuit Breaker					
	Without Reactor*1			With Reactor*2			Without Reactor*1			With Reactor*2		
	Model	Rated Current (A)	Rated breaking capacity (kA) Icu/Ics*3	Model	Rated Current (A)	Rated breaking capacity (kA) Icu/Ics*3	Model	Rated Current (A)	Rated breaking capacity (kA) Icu/Ics*3	Model	Rated Current (A)	Rated breaking capacity (kA) Icu/Ics*3
0.4	NV32-SV	5	10/10	NV32-SV	5	10/10	NF32-SV	5	7.5/7.5	NF32-SV	5	7.5/7.5
0.75	NV32-SV	10	10/10	NV32-SV	10	10/10	NF32-SV	10	7.5/7.5	NF32-SV	10	7.5/7.5
1.5	NV32-SV	15	10/10	NV32-SV	10	10/10	NF32-SV	15	7.5/7.5	NF32-SV	10	7.5/7.5
2.2	NV32-SV	20	10/10	NV32-SV	15	10/10	NF32-SV	20	7.5/7.5	NF32-SV	15	7.5/7.5
3.7	NV32-SV	30	10/10	NV32-SV	20	10/10	NF32-SV	30	7.5/7.5	NF32-SV	20	7.5/7.5
5.5	NV63-SV	50	15/15	NV63-SV	40	15/15	NF63-SV	50	15/15	NF63-SV	40	15/15
7.5	NV63-SV	60	15/15	NV63-SV	50	15/15	NF125-SV	60	50/50	NF63-SV	50	15/15
11	NV125-SV	75	50/50	NV125-SV	75	50/50	NF125-SV	75	50/50	NF125-SV	75	50/50
15	NV125-SV	125	50/50	NV125-SV	100	50/50	NF250-SV	125	85/85	NF125-SV	100	50/50
18.5	-	-	-	NV250-SV	125	85/85	-	-	-	NF250-SV	125	85/85
22	-	-	-	NV250-SV	150	85/85	-	-	-	NF250-SV	150	85/85
30	-	-	-	NV250-SV	175	85/85	-	-	-	NF250-SV	175	85/85
37	-	-	-	NV250-SV	225	85/85	-	-	-	NF250-SV	225	85/85
45	-	-	-	NV400-SW	250	42/42	-	-	-	NF400-CW	250	50/25
55	-	-	-	NV400-SW	300	42/42	-	-	-	NF400-CW	300	50/25
75	-	-	-	NV400-SW	400	42/42	-	-	-	NF400-CW	400	50/25
90	-	-	-	NV630-SW	500	42/42	-	-	-	NF630-CW	500	50/25
110	-	-	-	NV630-SW	600	42/42	-	-	-	NF630-CW	600	50/25

*1: The AC or DC reactor is not connected to the drive.

*2: The AC or DC reactor is connected to the drive.

*3: Icu: Rated ultimate short-circuit breaking capacity Ics: Rated service short-circuit breaking capacity

Note: Models of 18.5 to 110 kW are equipped with built-in DC reactor to improve power factor.

400 V Class

Motor Capacity (kW)	Ground Fault Interrupter (GFI)						Circuit Breaker					
	Without Reactor*1			With Reactor*2			Without Reactor*1			With Reactor*2		
	Model	Rated Current (A)	Rated breaking capacity (kA) Icu/Ics*3	Model	Rated Current (A)	Rated breaking capacity (kA) Icu/Ics*3	Model	Rated Current (A)	Rated breaking capacity (kA) Icu/Ics*3	Model	Rated Current (A)	Rated breaking capacity (kA) Icu/Ics*3
0.4	NV32-SV	3	5/5	NV32-SV	3	5/5	NF32-SV	3	2.5/2.5	NF32-SV	3	2.5/2.5
0.75	NV32-SV	5	5/5	NV32-SV	5	5/5	NF32-SV	5	2.5/2.5	NF32-SV	5	2.5/2.5
1.5	NV32-SV	10	5/5	NV32-SV	10	5/5	NF32-SV	10	2.5/2.5	NF32-SV	10	2.5/2.5
2.2	NV32-SV	15	5/5	NV32-SV	10	5/5	NF32-SV	15	2.5/2.5	NF32-SV	10	2.5/2.5
3.7	NV32-SV	20	5/5	NV32-SV	15	5/5	NF32-SV	20	2.5/2.5	NF32-SV	15	2.5/2.5
5.5	NV32-SV	30	5/5	NV32-SV	20	5/5	NF32-SV	30	2.5/2.5	NF32-SV	20	2.5/2.5
7.5	NV32-SV	30	5/5	NV32-SV	30	5/5	NF32-SV	30	2.5/2.5	NF32-SV	30	2.5/2.5
11	NV63-SV	50	7.5/7.5	NV63-SV	40	7.5/7.5	NF63-SV	50	7.5/7.5	NF63-SV	40	7.5/7.5
15	NV125-SV	60	25/25	NV63-SV	50	7.5/7.5	NF125-SV	60	18/18	NF63-SV	50	7.5/7.5
18.5	-	-	-	NV125-SV	60	25/25	-	-	-	NF125-SV	60	25/25
22	-	-	-	NV125-SV	75	25/25	-	-	-	NF125-SV	75	25/25
30	-	-	-	NV125-SV	100	25/25	-	-	-	NF125-SV	100	25/25
37	-	-	-	NV250-SV	125	36/36	-	-	-	NF250-SV	125	36/36
45	-	-	-	NV250-SV	150	36/36	-	-	-	NF250-SV	150	36/36
55	-	-	-	NV250-SV	175	36/36	-	-	-	NF250-SV	175	36/36
75	-	-	-	NV250-SV	225	36/36	-	-	-	NF250-SV	225	36/36
90	-	-	-	NV400-SW	250	42/42	-	-	-	NF400-CW	250	25/13
110	-	-	-	NV400-SW	300	42/42	-	-	-	NF400-CW	300	25/13
132	-	-	-	NV400-SW	350	42/42	-	-	-	NF400-CW	350	25/13
160	-	-	-	NV400-SW	400	42/42	-	-	-	NF400-CW	400	25/13
185	-	-	-	NV630-SW	500	42/42	-	-	-	NF630-CW	500	36/18
220	-	-	-	NV630-SW	630	42/42	-	-	-	NF630-CW	630	36/18
300	-	-	-	NV800-SEW	800	42/42	-	-	-	NF800-CEW	800	36/18

*1: The AC or DC reactor is not connected to the drive.

*2: The AC or DC reactor is connected to the drive.

*3: Icu: Rated ultimate short-circuit breaking capacity Ics: Rated service short-circuit breaking capacity

Note: Models of 18.5 to 110 kW are equipped with built-in DC reactor to improve power factor.

Magnetic Contactor

Connect Magnetic Contactor between power supply and Varispeed G7 input terminals R, S, and T, if required.

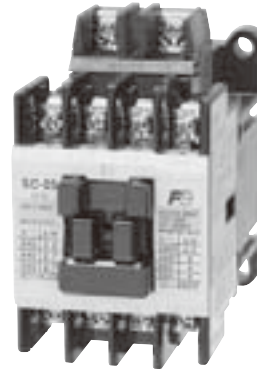

Magnetic Contactor
[Fuji Electric FA Components & Systems Co., Ltd]

200 V Class

Motor Capacity (kW)	Magnetic Contactor			
	Without Reactor*1		With Reactor*2	
	Model	Rated Current (A)	Model	Rated Current (A)
0.4	SC-03	11	SC-03	11
0.75	SC-05	13	SC-03	11
1.5	SC-4-0	18	SC-05	13
2.2	SC-N1	26	SC-4-0	18
3.7	SC-N2	35	SC-N1	26
5.5	SC-N2S	50	SC-N2	35
7.5	SC-N3	65	SC-N2S	50
11	SC-N4	80	SC-N4	80
15	SC-N5	93	SC-N4	80
18.5	—	—	SC-N5	93
22	—	—	SC-N6	125
30	—	—	SC-N7	152
37	—	—	SC-N8	180
45	—	—	SC-N10	220
55	—	—	SC-N11	300
75	—	—	SC-N12	400
90	—	—	SC-N12	400
110	—	—	SC-N14	600

*1: The AC or DC reactor is not connected to the drive.
 *2: The AC or DC reactor is connected to the drive.
 Note: Models of 18.5 to 110 kW are equipped with built-in DC reactor to improve power factor.

400 V Class

Motor Capacity (kW)	Magnetic Contactor			
	Without Reactor*1		With Reactor*2	
	Model	Rated Current (A)	Model	Rated Current (A)
0.4	SC-03	7	SC-03	7
0.75	SC-03	7	SC-03	7
1.5	SC-05	9	SC-05	9
2.2	SC-4-0	13	SC-4-0	13
3.7	SC-4-1	17	SC-4-1	17
5.5	SC-N2	32	SC-N1	25
7.5	SC-N2S	48	SC-N2	32
11	SC-N2S	48	SC-N2S	48
15	SC-N3	65	SC-N2S	48
18.5	—	—	SC-N3	65
22	—	—	SC-N4	80
30	—	—	SC-N4	80
37	—	—	SC-N5	90
45	—	—	SC-N6	110
55	—	—	SC-N7	150
75	—	—	SC-N8	180
90	—	—	SC-N10	220
110	—	—	SC-N11	300
132	—	—	SC-N11	300
160	—	—	SC-N12	400
185	—	—	SC-N12	400
220	—	—	SC-N14	600
300	—	—	SC-N16	800

*1: The AC or DC reactor is not connected to the drive.
 *2: The AC or DC reactor is connected to the drive.
 Note: Models of 18.5 to 110 kW are equipped with built-in DC reactor to improve power factor.

Noise Filter

Input Noise Filter

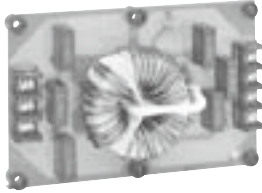

Manufactured by Yaskawa



Manufactured by Schaffner Elektronik AG

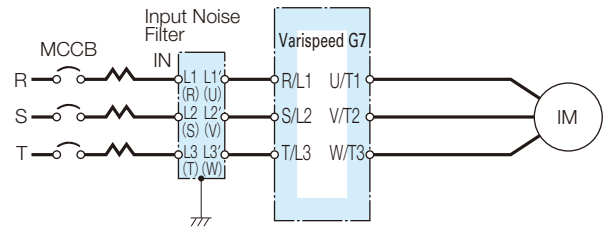

Example of Noise Filter Connection

Note: 1 Symbols in parentheses are for Yaskawa noise filters.
2 Be sure to connect input noise filter on Inverter input side (U, V, W).

200 V Class

Inverter Model CIMR-G7A	Max. Applicable Motor Output kW	Noise Filter without Case				Noise Filter with Case				Noise Filter by Schaffner Elektronik AG			
		Model	Code No.	Qty.	Rated Current A	Model	Code No.	Qty.	Rated Current A	Model	Code No.	Qty.	Rated Current A
20P4	0.4	LNFD-2103DY	FIL000132	1	10	LNFD-2103HY	FIL000140	1	10	—	—	—	—
20P7	0.75	LNFD-2103DY	FIL000132	1	10	LNFD-2103HY	FIL000140	1	10	—	—	—	—
21P5	1.5	LNFD-2103DY	FIL000132	1	10	LNFD-2103HY	FIL000140	1	10	—	—	—	—
22P2	2.2	LNFD-2153DY	FIL000133	1	15	LNFD-2153HY	FIL000141	1	15	—	—	—	—
23P7	3.7	LNFD-2303DY	FIL000135	1	30	LNFD-2303HY	FIL000143	1	30	—	—	—	—
25P5	5.5	LNFD-2203DY	FIL000134	2	40	LNFD-2203HY	FIL000142	2	40	FN258L-42-07	FIL001065	1	42
27P5	7.5	LNFD-2303DY	FIL000135	2	60	LNFD-2303HY	FIL000143	2	60	FN258L-55-07	FIL001066	1	55
2011	11	LNFD-2303DY	FIL000135	3	90	LNFD-2303HY	FIL000143	3	90	FN258L-75-34	FIL001067	1	75
2015	15	LNFD-2303DY	FIL000135	3	90	LNFD-2303HY	FIL000143	3	90	FN258L-100-35	FIL001068	1	100
2018	18.5	LNFD-2303DY	FIL000135	4	120	LNFD-2303HY	FIL000143	4	120	FN258L-130-35	FIL001069	1	130
2022	22	LNFD-2303DY	FIL000135	4	120	LNFD-2303HY	FIL000143	4	120	FN258L-130-35	FIL001069	1	130
2030	30	—	—	—	—	—	—	—	—	FN258L-180-07	FIL001070	1	180
2037	37	—	—	—	—	—	—	—	—	FN359P-250-99	FIL001071	1	250
2045	45	—	—	—	—	—	—	—	—	FN359P-250-99	FIL001071	1	250
2055	55	—	—	—	—	—	—	—	—	FN359P-300-99	FIL001072	1	300
2075	75	—	—	—	—	—	—	—	—	FN359P-400-99	FIL001073	1	400
2090	90	—	—	—	—	—	—	—	—	FN359P-500-99	FIL001074	1	500
2110	110	—	—	—	—	—	—	—	—	FN359P-600-99	FIL001075	1	600

Note: When two filters or more are required, connect them in parallel. (See Parallel Installation Example on P77.)
One noise filter is required if the filter is made by Schaffner Elektronik AG.

400 V Class

Inverter Model CIMR-G7A	Max. Applicable Motor Output kW	Noise Filter without Case				Noise Filter with Case				Noise Filter by Schaffner Elektronik AG			
		Model	Code No.	Qty.	Rated Current A	Model	Code No.	Qty.	Rated Current A	Model	Code No.	Qty.	Rated Current A
40P4	0.4	LNFD-4053DY	FIL000144	1	5	LNFD-4053HY	FIL000149	1	5	—	—	—	—
40P7	0.75	LNFD-4053DY	FIL000144	1	5	LNFD-4053HY	FIL000149	1	5	—	—	—	—
41P5	1.5	LNFD-4103DY	FIL000145	1	10	LNFD-4103HY	FIL000150	1	10	—	—	—	—
42P2	2.2	LNFD-4103DY	FIL000145	1	10	LNFD-4103HY	FIL000150	1	10	—	—	—	—
43P7	3.7	LNFD-4153DY	FIL000146	1	15	LNFD-4153HY	FIL000151	1	15	—	—	—	—
45P5	5.5	LNFD-4203DY	FIL000147	1	20	LNFD-4203HY	FIL000152	1	20	—	—	—	—
47P5	7.5	LNFD-4303DY	FIL000148	1	30	LNFD-4303HY	FIL000153	1	30	—	—	—	—
4011	11	LNFD-4203DY	FIL000147	2	40	LNFD-4203HY	FIL000152	2	40	FN258L-42-07	FIL001065	1	42
4015	15	LNFD-4303DY	FIL000148	2	60	LNFD-4303HY	FIL000153	2	60	FN258L-55-07	FIL001066	1	55
4018	18.5	LNFD-4303DY	FIL000148	2	60	LNFD-4303HY	FIL000153	2	60	FN258L-55-07	FIL001066	1	55
4022	22	LNFD-4303DY	FIL000148	3	90	LNFD-4303HY	FIL000153	3	90	FN258L-75-34	FIL001067	1	75
4030	30	LNFD-4303DY	FIL000148	3	90	LNFD-4303HY	FIL000153	3	90	FN258L-100-35	FIL001068	1	100
4037	37	LNFD-4303DY	FIL000148	4	120	LNFD-4303HY	FIL000153	4	120	FN258L-130-35	FIL001069	1	130
4045	45	LNFD-4303DY	FIL000148	4	120	LNFD-4303HY	FIL000153	4	120	FN258L-130-35	FIL001069	1	130
4055	55	—	—	—	—	—	—	—	—	FN258L-180-07	FIL001070	1	180
4075	75	—	—	—	—	—	—	—	—	FN359P-250-99	FIL001071	1	250
4090	90	—	—	—	—	—	—	—	—	FN359P-300-99	FIL001072	1	300
4110	110	—	—	—	—	—	—	—	—	FN359P-300-99	FIL001072	1	300
4132	132	—	—	—	—	—	—	—	—	FN359P-400-99	FIL001073	1	400
4160	160	—	—	—	—	—	—	—	—	FN359P-400-99	FIL001073	1	400
4185	185	—	—	—	—	—	—	—	—	FN359P-500-99	FIL001074	1	500
4220	220	—	—	—	—	—	—	—	—	FN359P-600-99	FIL001075	1	600
4300	300	—	—	—	—	—	—	—	—	FN359P-900-99	FIL001076	1	900

Note: When two filters or more are required, connect them in parallel. (See Parallel Installation Example on P77.)

Dimensions in mm Without Case

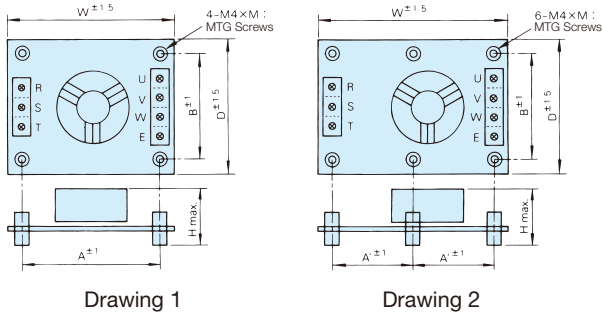

With Case

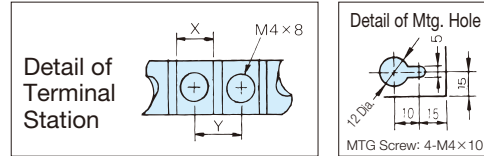
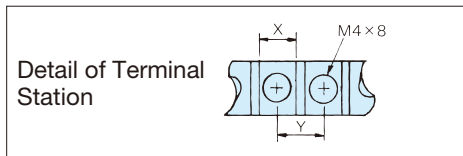
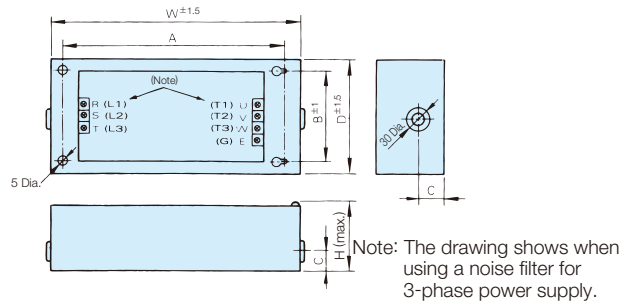

Model LNFD-□□□	Code No.	DWG	Noise Filter						Terminal		Mass kg
			W	D	H	A(A')	B	M	X	Y	
2103DY	FIL000132	1	120	80	55	108	68	20			0.2
2153DY	FIL000133	1	120	80	55	108	68	20	9	11	0.2
2203DY	FIL000134	1	170	90	70	158	78	20			0.4
2303DY	FIL000135	2	170	110	70	(79)	98	20	10	13	0.5
4053DY	FIL000144	2	170	130	75	(79)	118	30			0.3
4103DY	FIL000145	2	170	130	95	(79)	118	30	9	11	0.4
4153DY	FIL000146	2	170	130	95	(79)	118	30			0.4
4203DY	FIL000147	2	200	145	100	(94)	133	30			0.5
4303DY	FIL000148	2	200	145	100	(94)	133	30	10	13	0.6

Model LNFD-□□□	Code No.	W	D	H	Noise Filter			Terminal X	Terminal Y	Mass kg
					A	B	C			
2103HY	FIL000140	185	95	85	155	65	33			0.9
2153HY	FIL000141	185	95	85	155	65	33	9	11	0.9
2203HY	FIL000142	240	125	100	210	95	33			1.5
2303HY	FIL000143	240	125	100	210	95	33	10	13	1.6
4053HY	FIL000149	235	140	120	205	110	43			1.6
4103HY	FIL000150	235	140	120	205	110	43	9	11	1.7
4153HY	FIL000151	235	140	120	205	110	43			1.7
4203HY	FIL000152	270	155	125	240	125	43			2.2
4303HY	FIL000153	270	155	125	240	125	43	10	13	2.2

Manufactured by Schaffner Elektronik AG

Model	DWG	A	B	C	D	E	F	G	H	J	L	O	P	Mass kg
FN258L-42-07	1	329	185±1	70	300	314	45	6.5	500	1.5	12	M6	AWG8	2.8
FN258L-55-07	1	329	185±1	80	300	314	55	6.5	500	1.5	12	M6	AWG6	3.1
FN258L-75-34	2	329	220	80	300	314	55	6.5	—	1.5	—	M6	—	4.0
FN258L-100-35	2	379±1.5	220	90±0.8	350±1.2	364	65	6.5	—	1.5	—	M10	—	5.5
FN258L-130-35	2	439±1.5	240	110±0.8	400±1.2	414	80	6.5	—	3	—	M10	—	7.5
FN258L-180-07	3	438±1.5	240	110±0.8	400±1.2	413	80	6.5	500	4	15	M10	50 mm ²	11
FN359P-□□□□□□□□	4	See dimensions in the drawing.												See the table below.

Note: When using CE standard Inverters, the special EMC-compatible Noise Filter is required. Contact your Yaskawa representative.

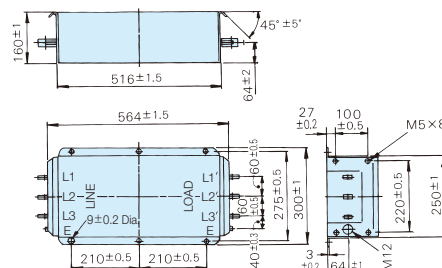
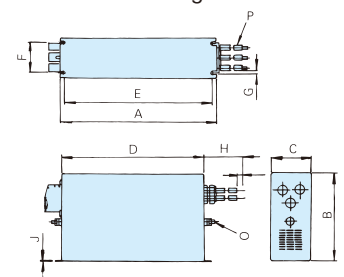
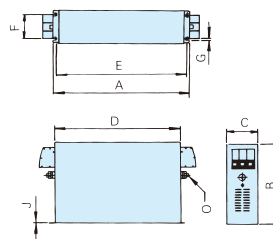
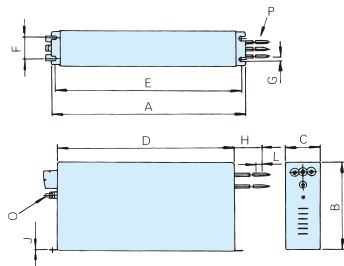

Model	Mass kg
FN359P-250-99	16
FN359P-300-99	16
FN359P-400-99	18.5
FN359P-500-99	19.5
FN359P-600-99	20.5
FN359P-900-99	33

Output Noise Filter (NEC TOKIN Corporation)

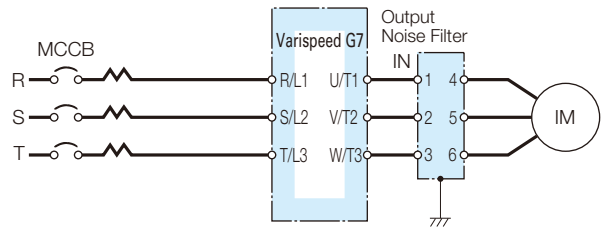

Example of Noise Filter Connection

200 V Class

Inverter CIMR-G7A	Max. Applicable Motor Output kW	Output Noise Filter			
		Model	Code No.	Qty.*1	Rated Current A
20P4	0.4	LF-310KA	FIL000068	1	10
20P7	0.75	LF-310KA	FIL000068	1	10
21P5	1.5	LF-310KA	FIL000068	1	10
22P2	2.2	LF-310KA	FIL000068	1	10
23P7	3.7	LF-320KA	FIL000069	1	20
25P5	5.5	LF-350KA	FIL000070	1	50
27P5	7.5	LF-350KA	FIL000070	1	50
2011	11	LF-350KA	FIL000070	2	100
2015	15	LF-350KA	FIL000070	2	100
2018	18.5	LF-350KA	FIL000070	2	100
2022	22	LF-350KA*2	FIL000070	3	150
		LF-3110KB*2	FIL000076	1	110
2030	30	LF-350KA*2	FIL000070	3	150
		LF-375KB*2	FIL000075	2	150
2037	37	LF-3110KB	FIL000076	2	220
2045	45	LF-3110KB	FIL000076	3	330
2055	55	LF-3110KB	FIL000076	4	440
2075	75	LF-3110KB	FIL000076	4	440
2090	90	LF-3110KB	FIL000076	4	440
2110	110	LF-3110KB	FIL000076	5	550

*1: When two filters or more are required, connect them in parallel.
*2: Use one of noise filters for the CIMR-G7A2022 or CIMR-G7A2030 model.

Dimensions in mm

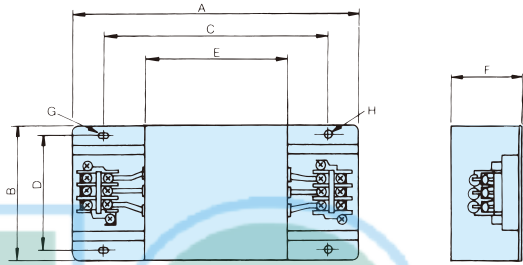

Model	Terminal Plate	A	B	C	D	E	F	G	H	Mass kg
LF-310KA	TE-K5.5M4	140	100	100	90	70	45	7×φ4.5	φ4.5	0.5
LF-320KA	TE-K5.5M4	140	100	100	90	70	45	7×φ4.5	φ4.5	0.6
LF-350KA	TE-K22 M6	260	180	180	160	120	65	7×φ4.5	φ4.5	2.0
LF-310KB	TE-K5.5M4	140	100	100	90	70	45	7×φ4.5	φ4.5	0.5
LF-320KB	TE-K5.5M4	140	100	100	90	70	45	7×φ4.5	φ4.5	0.6
LF-335KB	TE-K5.5M4	140	100	100	90	70	45	7×φ4.5	φ4.5	0.8
LF-345KB	TE-K22 M6	260	180	180	160	120	65	7×φ4.5	φ4.5	2.0
LF-375KB	TE-K22 M6	540	320	480	300	340	240	9×φ6.5	φ6.5	12.0
LF-3110KB	TE-K60 M8	540	340	480	300	340	240	9×φ6.5	φ6.5	19.5

400 V Class

Inverter CIMR-G7A	Max. Applicable Motor Output kW	Output Noise Filter			
		Model	Code No.	Qty.*	Rated Current A
40P4	0.4	LF-310KB	FIL000071	1	10
40P7	0.75	LF-310KB	FIL000071	1	10
41P5	1.5	LF-310KB	FIL000071	1	10
42P2	2.2	LF-310KB	FIL000071	1	10
43P7	3.7	LF-310KB	FIL000071	1	10
45P5	5.5	LF-320KB	FIL000072	1	20
47P5	7.5	LF-320KB	FIL000072	1	20
4011	11	LF-335KB	FIL000073	1	35
4015	15	LF-335KB	FIL000073	1	35
4018	18.5	LF-345KB	FIL000074	1	45
4022	22	LF-375KB	FIL000075	1	75
4030	30	LF-375KB	FIL000075	1	75
4037	37	LF-3110KB	FIL000076	1	110
4045	45	LF-3110KB	FIL000076	1	110
4055	55	LF-375KB	FIL000075	2	150
4075	75	LF-3110KB	FIL000076	2	220
4090	90	LF-3110KB	FIL000076	3	330
4110	110				
4132	132	LF-3110KB	FIL000076	4	440
4160	160				
4185	185				
4220	220				
4300	300	LF-3110KB	FIL000076	6	660

* When two filters or more are required, connect them in parallel.

Input/Output Side Noise Filter Parallel Installation Example

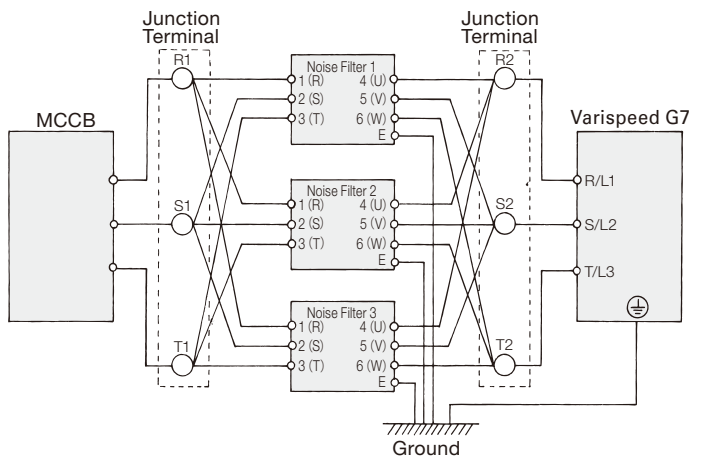

When wiring contactors in parallel, make sure wiring lengths are the same to keep current flow even to the relay terminals. Ground wires for noise filter and inverter should be thick and as short as possible.

Zero Phase Reactor

FINEMET Zero-phase Reactor to Reduce Radio Noise (Manufactured by Hitachi Metals, Ltd.)

Note: FINEMET is a registered trademark of Hitachi Metals, Ltd.

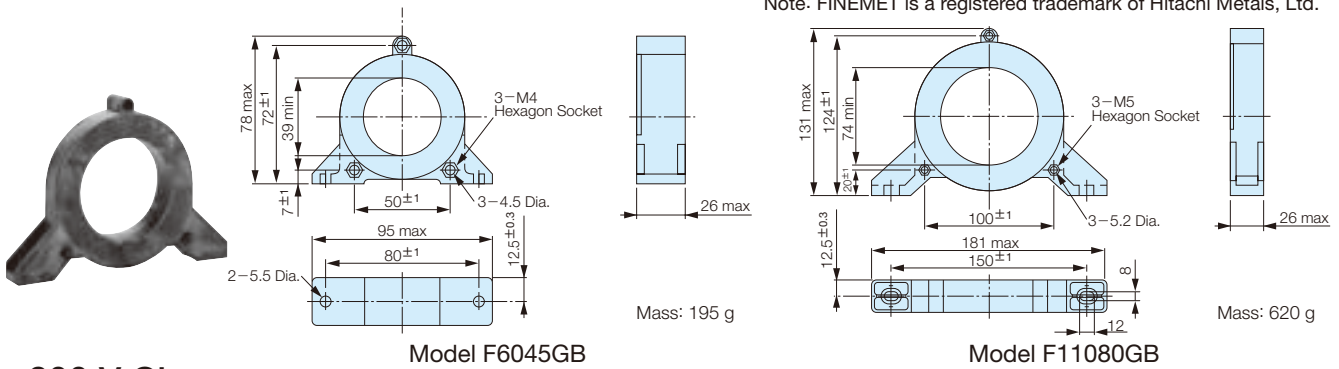

200 V Class

Inverter			FINEMET Zero-phase Reactor			
Model	Recommended Wire Size mm ²		Model	Code No.	Qty.	Recommended Wiring Method*2
	Input Side	Output Side				
CIMR-G7A20P4	2	2	F6045GB	FIL001098	1	4 passes through core (Diagram A)
CIMR-G7A20P7	2	2				
CIMR-G7A21P5	2	2				
CIMR-G7A22P2	3.5	3.5				
CIMR-G7A23P7	5.5	5.5				
CIMR-G7A25P5	8	8	F11080GB	FIL001097	4	4 series (Diagram B)
CIMR-G7A27P5	14	14				
CIMR-G7A2011	22	22				
CIMR-G7A2015	30	30				
CIMR-G7A2018	30	30				
CIMR-G7A2022	50	50	F11080GB	FIL001097	4	4 series (Diagram B)
CIMR-G7A2030	60	60				
CIMR-G7A2037	80	80				
CIMR-G7A2045	50×2P	50×2P				
CIMR-G7A2055	80×2P	80×2P				
CIMR-G7A2075	150×2P*1	100×2P	F200160PB	300-001-041	1	4 series (Diagram B)
CIMR-G7A2090	200×2P or 50×4P	150×2P*1 or 50×4P				
CIMR-G7A2110						

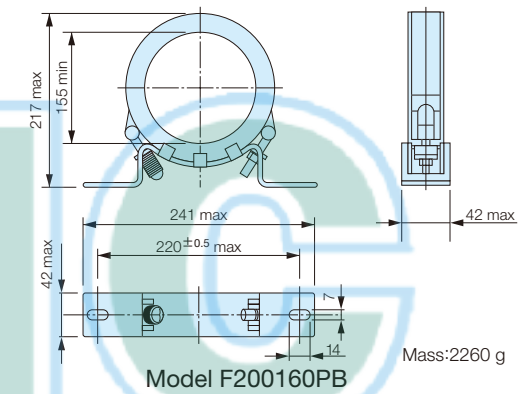

Can be used both for input and output sides of the Inverter and effective on noise reduction.

Connection Diagram A (Output)

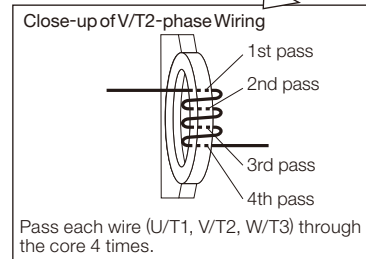
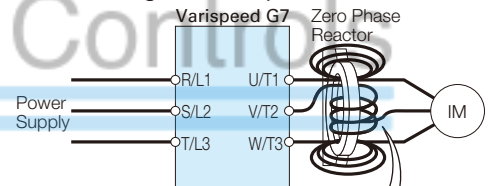

Connection Diagram B (Output)

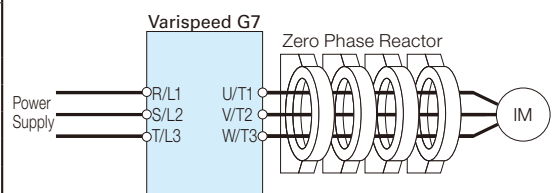

Put all wires (U/T1, V/T2, W/T3) through 4 cores in series without winding.

400 V Class

Inverter			FINEMET Zero-phase Reactor			
Model	Recommended Wire Size mm ²		Model	Code No.	Qty.	Recommended Wiring Method*2
	Input Side	Output Side				
CIMR-G7A40P4	2	2	F6045GB	FIL001098	1	4 passes through core (Diagram A)
CIMR-G7A40P7	2	2				
CIMR-G7A41P5	2	2				
CIMR-G7A42P2	3.5	3.5				
CIMR-G7A43P7	3.5	3.5				
CIMR-G7A45P5	5.5	5.5	F11080GB	FIL001097	4	4 series (Diagram B)
CIMR-G7A47P5	8	8				
CIMR-G7A4011	8	8				
CIMR-G7A4015	8	8				
CIMR-G7A4018	14	14				
CIMR-G7A4022	22	22	F6045GB	FIL001098	4	4 series (Diagram B)
CIMR-G7A4030	38	38				
CIMR-G7A4037	38	38				
CIMR-G7A4045	50	50				
CIMR-G7A4055	50	50				
CIMR-G7A4075	100	100	F11080GB	FIL001097	4	4 series (Diagram B)
CIMR-G7A4090	50×2P	50×2P				
CIMR-G7A4110	80×2P	80×2P				
CIMR-G7A4132	80×2P	80×2P				
CIMR-G7A4160	100×2P	100×2P				
CIMR-G7A4185	325	250	F200160PB	300-001-041	1	4 series (Diagram B)
CIMR-G7A4220	200×2P	150×2P*1				
CIMR-G7A4300	325×2P	250×2P				

*1: You can also use a FINEMET zero-phase reactor model (F11080GB).
*2: Determine this according to the wire size.

Fuse and Fuse Holder

Install a fuse to the drive input terminals to prevent damage in case a fault occurs.

Refer to the instruction manual for information on UL approved components.

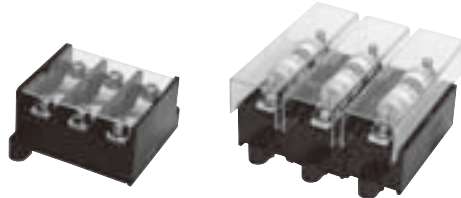

[Fuji Electric FA Components & Systems Co., Ltd]

Connection Diagram

DC Input Power Supply (example shows two Varispeed G7 drives connected in parallel) For use with an AC power supply see the connection diagram on page 16.

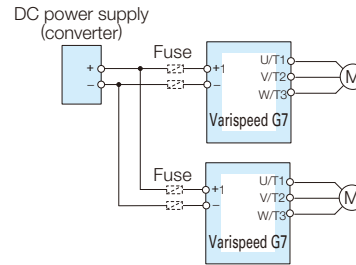

Note: When connecting multiple drives together, make sure that each drive has its own fuse. If any one fuse blows, all fuses should be replaced.

Voltage	Inverter		AC Power Supply Input				DC Power Supply Input				
	Model CIMR-G7A ()	Model	Rated Interrupt Current (kA)	Qty.	Model	Qty.	Model	Rated Interrupt Current (kA)	Qty.	Model	Qty.
200 V Class	20P4	CR2LS-30	100	3	CM-1A	1	CR2LS-30	100	2	CM-1A	1
	20P7						CR2LS-50				
	21P5	CR2LS-100					CR2LS-100				
	22P2	CR2L-125					CR2L-125				
	23P7	CR2L-150					CR2L-150				
	25P5	CR2L-175					CR2L-175				
	27P5	CR2L-225			CR2L-225	CM-2A	1				
	2011	CR2L-260			CR2L-260						
	2015	CR2L-300			CR2L-300	*	*				
	2018	CR2L-350			CR2L-350						
	2022	CR2L-400			CR2L-400						
	2030	CR2L-450			CR2L-450						
	2037	CR2L-600			CR2L-600						
	2045	CR2L-600			CR2L-600						
	2055	CR2L-600			CR2L-600						
	2075	CR2L-600			CR2L-600						
2090	CR2L-600	CR2L-600									
2110	CS5F-800	CS5F-800	200	2	CM-2A			1			
40P4	CR6L-20	100	3	CMS-4		3	CR6L-20		100	2	CMS-4
40P7	CR6L-30				CR6L-30						
41P5	CR6L-50				CR6L-50						
42P2											
43P7	CR6L-75				CR6L-75						
45P5											
47P5	CR6L-100			CR6L-100	CMS-5	3					
4011	CR6L-150			CR6L-150							
4015	CR6L-200			CR6L-200	*	*					
4018	CR6L-250			CR6L-250							
4022	CR6L-300			CR6L-300							
4030	CR6L-350			CR6L-350							
4037	CR6L-400			CR6L-400							
4045	CS5F-600			CS5F-600			200	2			
4055	CS5F-600			CS5F-600							
4075	CS5F-600			CS5F-600							
4090	CS5F-600	CS5F-600									
4110	CS5F-600	CS5F-600									
4132	CS5F-600	CS5F-600									
4160	CS5F-800	CS5F-800									
4185	CS5F-800	CS5F-800									
4220	CS5F-800	CS5F-800									
4300	CS5F-1000	CS5F-1000	200	2	*	*					

* Manufacturer does not recommend a specific fuse holder for this fuse. Contact the manufacturer for information on fuse dimensions.

Braking Unit, Braking Resistor, Braking Resistor Unit

To supply braking for Inverter, a braking unit and a braking resistor unit is needed. 0.4 to 15 kW (200 V/400 V) Inverters are equipped with braking units as standard. Connect Inverter-mounted or separately-installed type units according to Inverter applications and output.



Separately-installed Type Braking Unit



Inverter-mounted Type Braking Resistor



Separately-installed Type Braking Resistor Unit

Inverter			Braking unit		Braking Resistor Unit*1												
					Inverter-mounted Type (3%ED,10 s max.)*2						Separately-installed Type (10%ED,10 s max.)*3						
Voltage	Max. Applicable Motor Output kW	Model CIMR-G7A	Model CDBR	No. of Used	Model ERF-150WJ	Resistance	Code No.	No. of Used	Braking Torque*5 %	Diagram	Model LKEB	Specifications of Resistor	No. of Used	Braking Torque*5 %	Connectable Min. Resistance Value*4 Ω	Diagram	
					200 V Class	0.4	20P4	Built-in		201	200 Ω	R007505	1	220	A	20P7	70 W 200 Ω
0.75	20P7	201	200 Ω	R007505		1	125			A	20P7	70 W 200 Ω	1	125	48 Ω	B	
1.5	21P5	101	100 Ω	R007504		1	125			A	21P5	260 W 100 Ω	1	125	16 Ω	B	
2.2	22P2	700	70 Ω	R007503		1	120			A	22P2	260 W 70 Ω	1	120	16 Ω	B	
3.7	23P7	620	62 Ω	R007510		1	80			A	23P7	390 W 40 Ω	1	125	16 Ω	B	
5.5	25P5	—	—	—		—	—			—	25P5	520 W 30 Ω	1	115	9.6 Ω	B	
7.5	27P5	—	—	—		—	—			—	27P5	780 W 20 Ω	1	125	9.6 Ω	B	
11	2011	—	—	—		—	—			—	2011	2400 W 13.6 Ω	1	125	9.6 Ω	B	
15	2015	—	—	—		—	—			—	2015	3000 W 10 Ω	1	125	9.6 Ω	B	
18.5	2018	2022D	1	—		—	—			—	—	2018	4800 W 8 Ω	1	125	6.4 Ω	C
22	2022	2022D	1	—		—	—			—	—	2022	4800 W 6.8 Ω	1	125	6.4 Ω	C
30	2030	2037D	1	—		—	—			—	—	2015	3000 W 10 Ω	2	125	5 Ω	E
37	2037	2037D	1	—		—	—			—	—	2015	3000 W 10 Ω	2	100	5 Ω	E
45	2045	2022D	2	—		—	—			—	—	2022	4800 W 6.8 Ω	2	120	6.4 Ω	D
55	2055	2022D	2	—		—	—			—	—	2022	4800 W 6.8 Ω	2	100	6.4 Ω	D
75	2075	2110D	1	—		—	—	—	—	2022	4800 W 6.8 Ω	3	110	1.6 Ω	E		
90	2090	2110D	1	—	—	—	—	—	2022	4800 W 6.8 Ω	4	120	1.6 Ω	E			
110	2110	2110D	1	—	—	—	—	—	2018	4800 W 8 Ω	5	100	1.6 Ω	E			
400 V Class	0.4	40P4	Built-in		751	750 Ω	R007508	1	230	A	40P7	70 W 750 Ω	1	230	96 Ω	B	
	0.75	40P7			751	750 Ω	R007508	1	130	A	40P7	70 W 750 Ω	1	130	96 Ω	B	
	1.5	41P5			401	400 Ω	R007507	1	125	A	41P5	260 W 400 Ω	1	125	64 Ω	B	
	2.2	42P2			301	300 Ω	R007506	1	115	A	42P2	260 W 250 Ω	1	135	64 Ω	B	
	3.7	43P7			201	200 Ω	R007505	1	105	A	43P7	390 W 150 Ω	1	135	32 Ω	B	
	5.5	45P5			—	—	—	—	—	—	45P5	520 W 100 Ω	1	135	32 Ω	B	
	7.5	47P5			—	—	—	—	—	—	47P5	780 W 75 Ω	1	130	32 Ω	B	
	11	4011			—	—	—	—	—	—	4011	1040 W 50 Ω	1	135	20 Ω	B	
	15	4015			—	—	—	—	—	—	4015	1560 W 40 Ω	1	125	20 Ω	B	
	18.5	4018			4030D	1	—	—	—	—	—	4018	4800 W 32 Ω	1	125	19.2 Ω	C
	22	4022			4030D	1	—	—	—	—	—	4022	4800 W 27.2 Ω	1	125	19.2 Ω	C
	30	4030			4030D	1	—	—	—	—	—	4030	6000 W 20 Ω	1	125	19.2 Ω	C
	37	4037			4045D	1	—	—	—	—	—	4037	9600 W 16 Ω	1	125	12.8 Ω	C
	45	4045			4045D	1	—	—	—	—	—	4045	9600 W 13.6 Ω	1	125	12.8 Ω	C
	55	4055			4030D	2	—	—	—	—	—	4030	6000 W 20 Ω	2	135	19.2 Ω	D
	75	4075	4045D	2	—	—	—	—	—	4045	9600 W 13.6 Ω	2	145	12.8 Ω	D		
	90	4090	4220D	1	—	—	—	—	—	4030	6000 W 20 Ω	3	100	3.2 Ω	E		
	110	4110	4220D	1	—	—	—	—	—	4030	6000 W 20 Ω	3	100	3.2 Ω	E		
	132	4132	4220D	1	—	—	—	—	—	4045	9600 W 13.6 Ω	4	140	3.2 Ω	E		
	160	4160	4220D	1	—	—	—	—	—	4045	9600 W 13.6 Ω	4	140	3.2 Ω	E		
185	4185	4220D	1	—	—	—	—	—	4045	9600 W 13.6 Ω	4	120	3.2 Ω	E			
220	4220	4220D	1	—	—	—	—	—	4037	9600 W 16 Ω	5	110	3.2 Ω	E			
300	4300	4220D	2	—	—	—	—	—	4045	9600 W 13.6 Ω	6	110	3.2 Ω	F			

*1: When connecting a mounting type resistor or braking resistor unit, set system constant L3-04 to 0 (stall prevention disabled during deceleration). If operating without changing the constant, motor does not stop at set deceleration time.

*2: When connecting mounting type braking resistor, set system constant L8-01 to 1 (braking resistor protection enabled).

*3: Load factor during deceleration to stop a load with constant torque. With constant output or continuous regenerative braking, the load factor is smaller than the specified value.

*4: Resistance value per one braking unit. Select a resistance value that is larger than connectable minimum resistance value to obtain enough braking torque.

*5: For an application with large regenerative power such as hoisting, the braking torque or other items may exceed the capacity of a braking unit with a braking resistor in a standard combination (and result in capacity overload). Contact your Yaskawa representatives when the braking torque or any other item exceeds the values in the table.

Connections

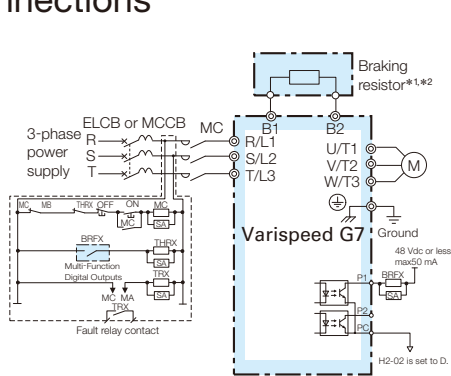

Connection Diagram A

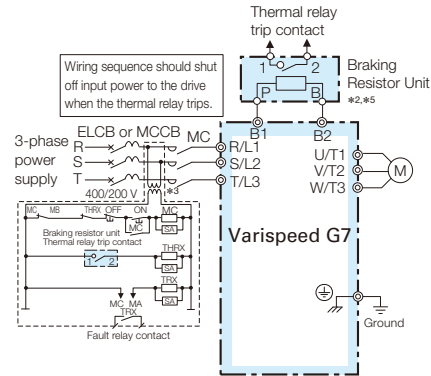

Connection Diagram B

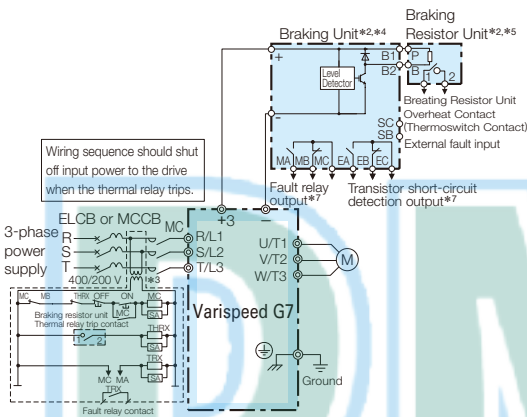

Connection Diagram C

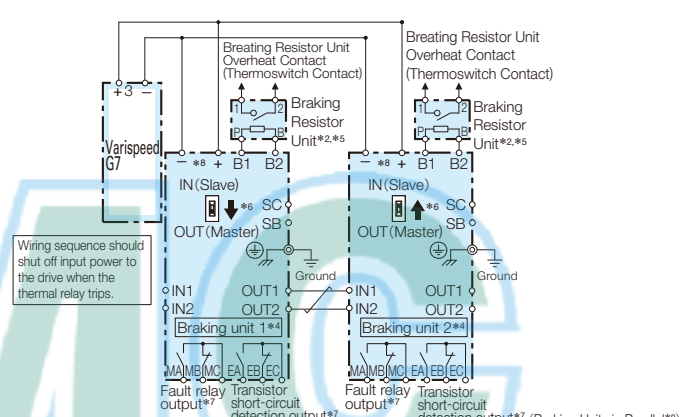

Connection Diagram D

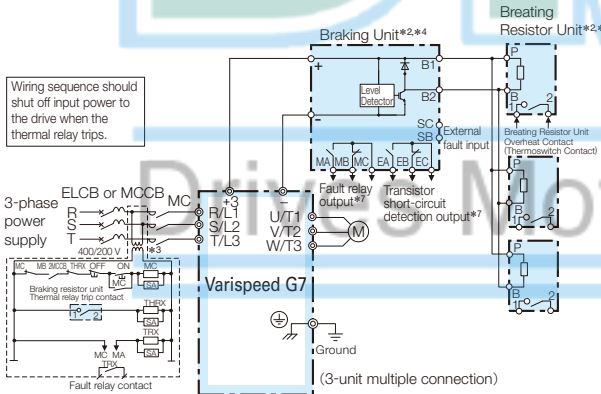

Connection Diagram E

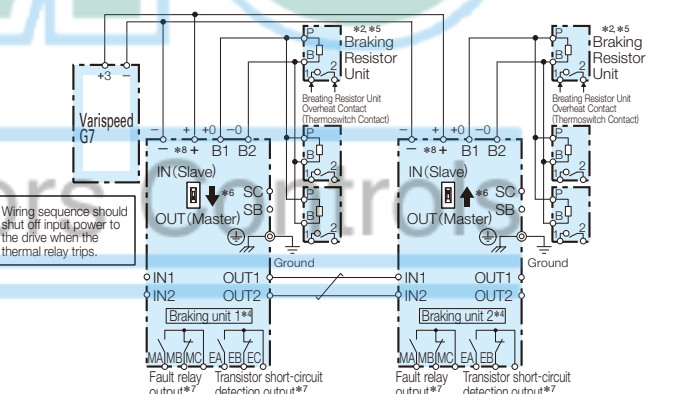

Connection Diagram F

- *1: Set L8-01 to 1 to enable braking resistor overload protection in the drive when using braking resistors, and set a multi-function input to "Braking Resistor Fault" (H1-□□□□ = D). Wiring sequence should shut off power to the drive when a fault output is triggered.
- *2: Set L3-04 to 0 or 3 to disable stall prevention when using a braking unit, a braking resistor, or a braking resistor unit. If the function is enabled under these conditions, the drive may not stop within the specified deceleration time.
- *3: 200 V class drives do not require a control circuit transformer.
- *4: When connecting a separately-installed type braking resistor unit (model CDBR) to drives with a built-in braking transistor (200 V/400 V 15 kW or less), connect the B1 terminal of the drive to the positive terminal of the braking resistor unit and connect the negative terminal of the drive to the negative terminal of the braking resistor unit. The B2 terminal is not used in this case.

- *5: Be sure to protect non-Yaskawa braking resistors by thermal overload relay.
- *6: When using more than one braking unit connected in parallel, set one of the braking units as the master, and set the others as slaves.
- *7: Connect fault relay output to multi-function digital input S□□□(External Fault). Connect the CDBR transistor short-circuit detection output to disconnect main input power to the drive.
- *8: Connect directly to the drive terminal or install a terminal block.
- *9: Contact your Yaskawa representative or nearest agent when using the braking unit (CDBR-□□D) with earlier models (CDBR-□□B or CDBR-□□C).

Model, Code No.

■ Braking Unit

200 V Class

Model CDBR-□□□□□□□□	Protection Design	Code No.
2022D	IP20	100-091-707
	UL Type1	100-091-754
2037D	IP20	100-091-712
	UL Type1	100-091-759
2110D	IP00	100-091-524
	UL Type1	100-091-530

400 V Class

Model CDBR-□□□□□□□□	Protection Design	Code No.
4030D	IP20	100-091-717
	UL Type1	100-091-764
4045D	IP20	100-091-722
	UL Type1	100-091-769
4220D	IP00	100-091-526
	UL Type1	100-091-532

Dimensions mm

■ Braking Unit

Open Chassis [IP20]

CDBR-2022D, -2037D, -4030D, -4045D

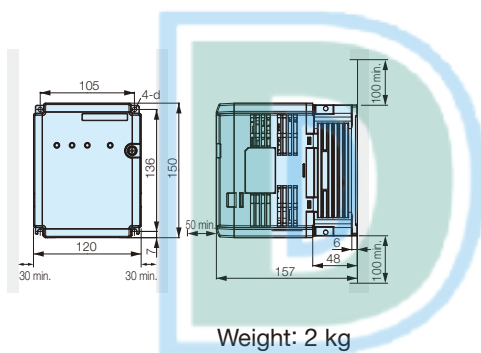

Open Chassis [IP00]

CDBR-2110D, -4220D

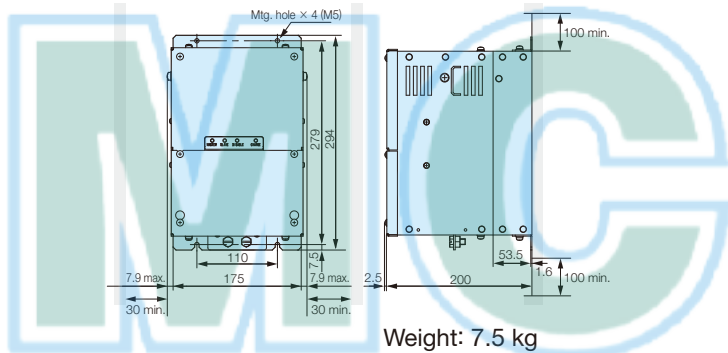

Enclosure Wall-Mounted [UL Type1]

CDBR-2022D, -2037D,
-4030D, -4045D

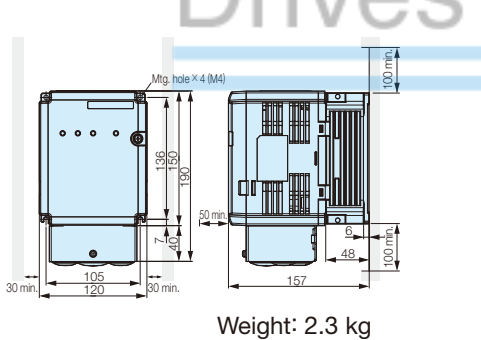

CDBR-2110D, -4220D

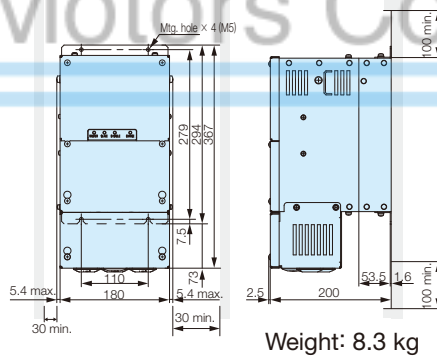

Note: Remove the top protective cover when installing the Inverter in a control panel to convert the Inverter to an IP20 enclosure.

Heat Loss

Model CDBR-□□□□□□□□	Heat Loss (W)
2022D	27
2037D	38
2110D	152
4030D	24
4045D	36
4220D	152

■ Braking Resistor (Inverter-mounted Type)

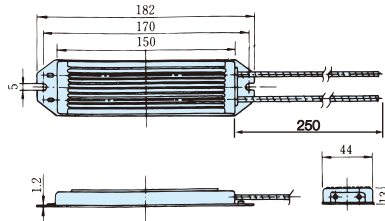

Note: Prepare mounting screws
(2-M4×8 tapped screws).
(Screws 8 mm or more and general
metric screws cannot be used.)

Mass : 0.2 kg
(Model ERF-150WJ)

■ Braking Resistor Unit (Separately-installed Type)

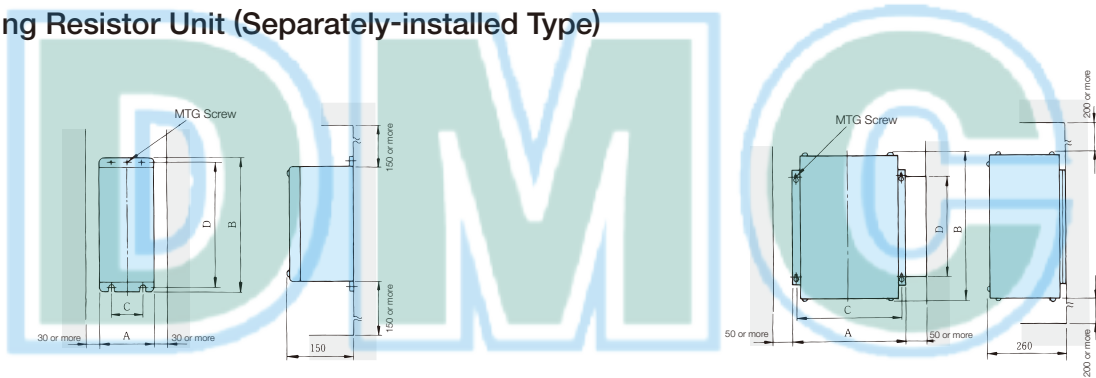

Voltage	Model LKEB-□□□	Dimensions in mm					Mass kg	Average Allowable Power Consumption W
		A	B	C	D	MTG Screw		
200 V Class	20P7	105	275	50	260	M5×3	3.0	30
	21P5	130	350	75	335	M5×4	4.5	60
	22P2	130	350	75	335	M5×4	4.5	89
	23P7	130	350	75	335	M5×4	5.0	150
	25P5	250	350	200	335	M6×4	7.5	220
	27P5	250	350	200	335	M6×4	8.5	300
400 V Class	40P7	105	275	50	260	M5×3	3.0	30
	41P5	130	350	75	335	M5×4	4.5	60
	42P2	130	350	75	335	M5×4	4.5	89
	43P7	130	350	75	335	M5×4	5.0	150
	45P5	250	350	200	335	M6×4	7.5	220
	47P5	250	350	200	335	M6×4	8.5	300

Voltage	Model LKEB-□□□	Dimensions in mm					Mass kg	Average Allowable Power Consumption W
		A	B	C	D	MTG Screw		
200 V Class	2011	266	543	246	340	M8×4	10	440
	2015	356	543	336	340	M8×4	15	600
	2018	446	543	426	340	M8×4	19	740
	2022	446	543	426	340	M8×4	19	880
	4011	350	412	330	325	M6×4	16	440
400 V Class	4015	350	412	330	325	M6×4	18	600
	4018	446	543	426	340	M8×4	19	740
	4022	446	543	426	340	M8×4	19	880
	4030	356	956	336	740	M8×4	25	1200
	4037	446	956	426	740	M8×4	33	1500
4045	446	956	426	740	M8×4	33	1800	

■ Braking Unit External Heatsink Attachment

Use the external heatsink attachment for installation with the heatsink outside the enclosure.

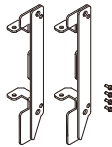
Attachment	Model CDBR-.....	Model (Code No.)
	2022D	EZZ021711A (100-066-355)
	2037D	
	4030D	
	4045D	

Dimensions (mm)

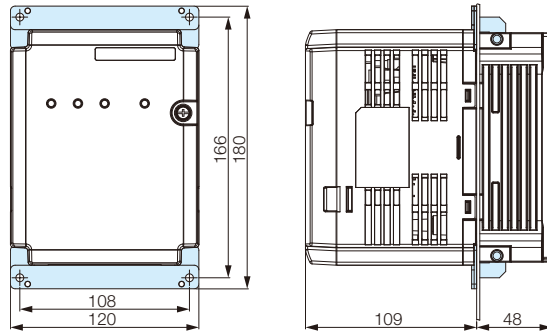

■ Braking Unit Panel Cutout Dimensions

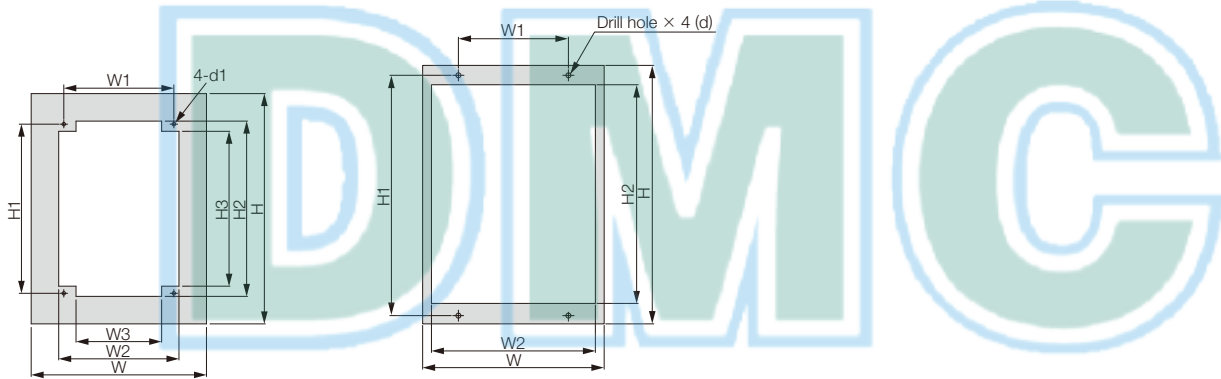

Modification Figure1

Modification Figure2

Model CDBR-.....	Modification Figure	Dimensions (mm)								
		W*	H*	W1	W2	W3	H1	H2	H3	d1
2022D	1	172	226	108	118	84	166	172	152	M4
2037D	1	172	226	108	118	84	166	172	152	M4
2110D	2	175	294	110	159	—	279	257.8	—	M5
4030D	1	172	226	108	118	84	166	172	152	M4
4045D	1	172	226	108	118	84	166	172	152	M4
4220D	2	175	294	110	159	—	279	257.8	—	M5

* The following W, H information is the size when in installing the gasket.

DC Reactor (UZDA-B for DC circuit)

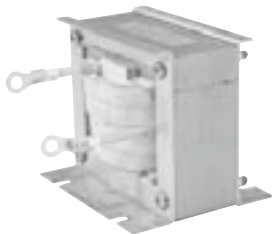

When power capacity is significantly greater when compared to Inverter capacity, or when the power-factor needs to be improved, connect the AC or DC reactor. DC reactor is built in 18.5 to 110 kW, 200 V class Inverters and 18.5 to 300 kW, 400 V class Inverters. AC reactor can be used at the same time for harmonic measure.

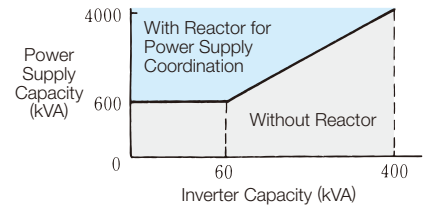
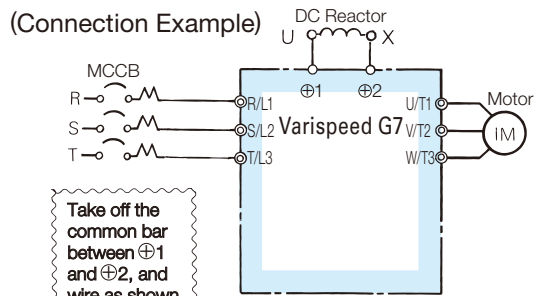

200 V Class

Max. Applicable Motor Output kW	Current Value A	Inductance mH	Code No.	Drawing	Dimensions in mm										Approx. Mass kg	Loss W	Wire* Size mm ²
					X	Y ₂	Y ₁	Z	B	H	K	G	φ1	φ2			
0.4	5.4	8	X010048	1	85	—	—	53	74	—	—	32	M4	—	0.8	8	2
0.75					86	80	36	76	60	55	18	—	M4	M5	2.0	18	5.5
1.5	18	3	X010049	2	105	90	46	93	64	80	26	—	M6	M6	3.2	22	8
2.2					105	105	56	93	64	100	26	—	M6	M8	4.9	29	30
3.7	36	1	X010050	2	105	90	46	93	64	80	26	—	M6	M6	3.2	22	8
5.5					105	90	46	93	64	80	26	—	M6	M6	3.2	22	8
7.5	72	0.5	X010051	2	105	90	46	93	64	80	26	—	M6	M6	3.2	22	8
11					105	90	46	93	64	80	26	—	M6	M6	3.2	22	8
15	72	0.5	X010051	2	105	90	46	93	64	80	26	—	M6	M6	3.2	22	8
18.5 to 110	Built-in																

400 V Class

Max. Applicable Motor Output kW	Current Value A	Inductance mH	Code No.	Drawing	Dimensions in mm										Approx. Mass kg	Loss W	Wire* Size mm ²
					X	Y ₂	Y ₁	Z	B	H	K	G	φ1	φ2			
0.4	3.2	28	X010052	1	85	—	—	53	74	—	—	32	M4	—	0.8	9	2
0.75					90	—	—	60	80	—	—	32	M4	—	1.0	11	2
1.5	5.7	11	X010053	1	90	—	—	60	80	—	—	32	M4	—	1.0	11	2
2.2					86	80	36	76	60	55	18	—	M4	M5	2.0	16	2
3.7	12	6.3	X010054	2	105	90	46	93	64	80	26	—	M6	M5	3.2	27	5.5
5.5					105	90	46	93	64	80	26	—	M6	M5	3.2	27	5.5
7.5	23	3.6	X010055	2	105	90	46	93	64	80	26	—	M6	M5	3.2	27	5.5
11					105	95	51	93	64	90	26	—	M6	M6	4.0	26	8
15	33	1.9	X010056	2	105	95	51	93	64	90	26	—	M6	M6	4.0	26	8
18.5 to 300	Built-in																

* 75°C, IV wire, ambient temperature 45°C, bundle of max. 3 wires

Dimensions in mm

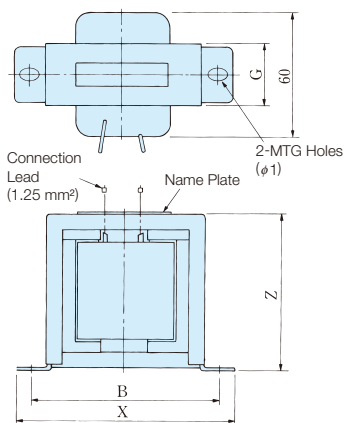

Drawing 1

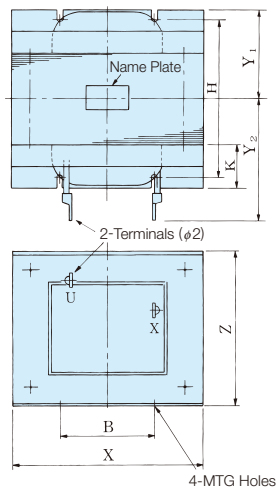

Drawing 2

Terminal Type

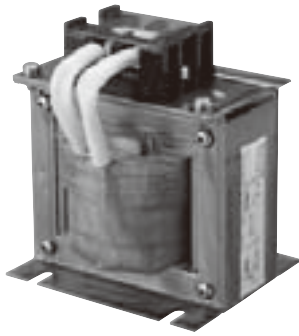

200 V Class

Max. Applicable Motor Output kW	Current Value A	Inductance mH	Code No.	Drawing	Dimensions in mm										Approx. Mass kg	Loss W
					X	Y ₂	Y ₁	Z	B	H	K	G	φ1	φ2		
0.4 0.75	5.4	8	300-027-130	1	85	—	—	81	74	—	—	32	M4	M4	0.8	8
1.5 2.2 3.7	18	3	300-027-131	2	86	84	36	101	60	55	18	—	M4	M4	2	18
5.5 7.5	36	1	300-027-132		105	94	46	129	64	80	26	—	M6	M4	3.2	22
11 15	72	0.5	300-027-133		105	124	56	135	64	100	26	—	M6	M6	4.9	29

400 V Class

Max. Applicable Motor Output kW	Current Value A	Inductance mH	Code No.	Drawing	Dimensions in mm										Approx. Mass kg	Loss W
					X	Y ₂	Y ₁	Z	B	H	K	G	φ1	φ2		
0.4 0.75	3.2	28	300-027-134	1	85	—	—	81	74	—	—	32	M4	M4	0.8	9
1.5 2.2	5.7	11	300-027-135	2	90	—	—	88	80	—	—	32	M4	M4	1	11
3.7 5.5	12	6.3	300-027-136		86	84	36	101	60	55	18	—	M4	M4	2	16
7.5 11 15	23 33	3.6 1.9	300-027-137 300-027-138		105 105	104 109	46 51	118 129	64 64	80 90	26 26	—	M6 M6	M4 M4	3.2 4	27 26

Dimensions in mm

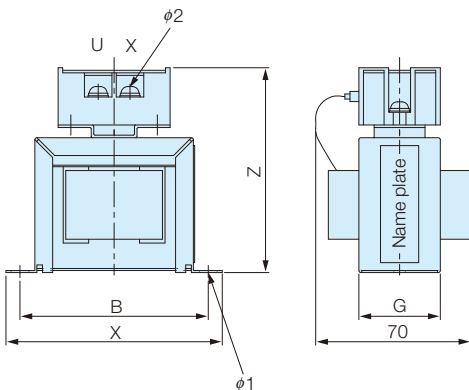

Drawing 1

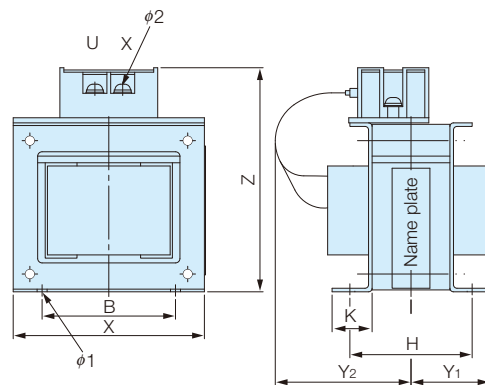

Drawing 2

AC Reactor (UZBA-B for Input 50/60 Hz)



(Connection Diagram)

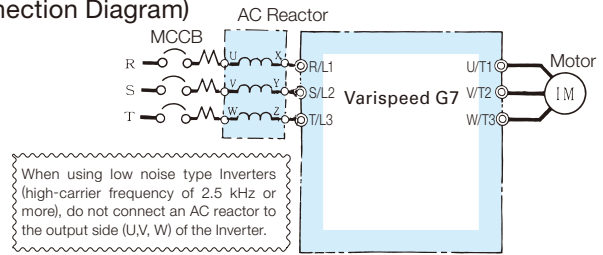

When power capacity is significantly greater when compared to Inverter capacity, or when the power-factor needs to be improved, connect the AC or DC reactor.

DC reactor is built in 18.5 to 110 kW, 200 V class Inverters and 18.5 to 300 kW, 400 V class Inverters. Select an AC reactor according to the motor capacity listed in the following tables.

200 V Class

Max. Applicable Motor Output kW	Current Value A	Inductance mH	Code No.	Drawing	Dimensions in mm											Approx. Mass kg	Loss W			
					A	B	B1	C	D	E	F	H	I	J	K			L	M	
3.7	20	0.53	X002491	1	130	88	114	105	50	70	130	22	3.2	M6	11.5	7	M5	3	35	
5.5	30	0.35	X002492		130	88	119	105	50	70	130	22	3.2	M6	9	7	M5	3	45	
7.5	40	0.265	X002493		130	98	139	105	50	80	130	22	3.2	M6	11.5	7	M6	4	50	
11	60	0.18	X002495		160	105	147.5	130	75	85	160	25	2.3	M6	10	7	M6	6	65	
15	80	0.13	X002497		180	100	155	150	75	80	180	25	2.3	M6	10	7	M8	8	75	
18.5	90	0.12	X002498		180	100	150	150	75	80	180	25	2.3	M6	10	7	M8	8	90	
22	120	0.09	X002555		180	100	155	150	75	80	180	25	2.3	M6	10	7	M10	8	90	
30	160	0.07	X002556		210	100	170	175	75	80	205	25	3.2	M6	10	7	M10	12	100	
37	200	0.05	X002557		210	115	182.5	175	75	95	205	25	3.2	M6	10	7	M10	15	110	
45	240	0.044	X002558		240	126	218	215	150	110	240	25	3.2	M8	8	7	M10	23	125	
55	280	0.039	X002559		240	126	218	215	150	110	240	25	3.2	M8	8	10	M12	23	130	
75	360	0.026	X002560		270	162	241	230	150	130	260	40	5	M8	16	10	M12	32	145	
90	500	0.02	X010145		2	330	162	281	270	150	130	320	40	4.5	M10	16	10	M12	55	200
110	500	0.02	X010145			330	162	281	270	150	130	320	40	4.5	M10	16	10	M12	55	200

400 V Class

Max. Applicable Motor Output kW	Current Value A	Inductance mH	Code No.	Drawing	Dimensions in mm											Approx. Mass kg	Loss W			
					A	B	B1	C	D	E	F	H	I	J	K			L	M	
7.5	20	1.06	X002502	1	160	90	115	130	75	70	160	25	2.3	M6	10	7	M5	5	50	
11	30	0.7	X002503		160	105	132.5	130	75	85	160	25	2.3	M6	10	7	M5	6	65	
15	40	0.53	X002504		180	100	140	150	75	80	180	25	2.3	M6	10	7	M6	8	90	
18.5	50	0.42	X002505		180	100	145	150	75	80	180	25	2.3	M6	10	7	M6	8	90	
22	60	0.36	X002506		180	100	150	150	75	80	180	25	2.3	M6	10	7	M6	8.5	90	
30	80	0.26	X002508		210	100	150	175	75	80	205	25	3.2	M6	10	7	M8	12	95	
37	90	0.24	X002509		210	115	177.5	175	75	95	205	25	3.2	M6	10	7	M8	15	110	
45	120	0.18	X002566		240	126	193	205	150	110	240	25	3.2	M8	8	10	M10	23	130	
55	150	0.15	X002567		240	126	198	205	150	110	240	25	3.2	M8	8	10	M10	23	150	
75	200	0.11	X002568		270	162	231	230	150	130	260	40	5	M8	16	10	M10	32	135	
90/110	250	0.09	X002569		270	162	246	230	150	130	260	40	5	M8	16	10	M12	32	135	
132/160	330	0.06	X002570		3	320	165	253	275	150	130	320	40	5	M10	17.5	12	M12	55	200
185	490	0.04	X002690			330	176	293	275	150	150	320	40	4.5	M10	13	12	M12	60	340
220	490	0.04	X002690			330	176	293	275	150	150	320	40	4.5	M10	13	12	M12	60	340
300	660	0.03	300-032-353	330		216	353	285	150	185	320	40	4.5	M10	22	12	M16	80	310	
				330		216	353	285	150	185	320	40	4.5	M10	22	12	M16	80	310	

Dimensions in mm

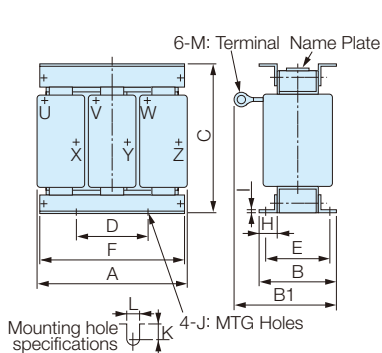

Drawing 1

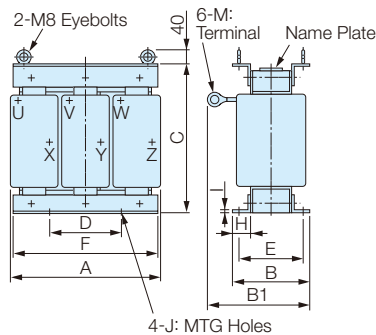

Drawing 2

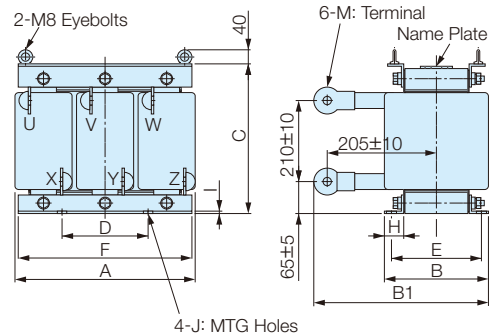

Drawing 3

Terminal Type

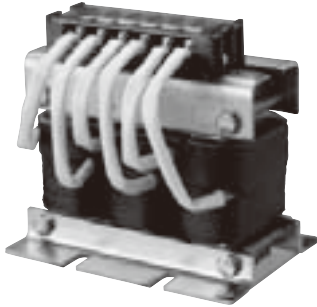

200 V Class

Max. Applicable Motor Output kW	Current Value A	Inductance mH	Code No.	Drawing	Dimensions in mm												Approx. Mass kg	Loss W												
					A	B	B1	C	D	E	F	H	I	J	K	L			M											
0.4	2.5	4.2	X002553	1	120	71		120	40	50	105	20	2.3		10.5		M4	2.5	15											
0.75	5	2.1	X002554		130	88		130	50	70	130	22	3.2		9	7		3	25											
1.5	10	1.1	X002489		2	135	88	140	130	50	70	130	22	3.2	M6	9	7	M5	3	30										
2.2	15	0.71	X002490					150											3	45										
3.7	20	0.53	300-027-120					135											98	160	140	50	80	130	22	3.2	9	M6	4	50
5.5	30	0.35	300-027-121	2	165	105	185	170	75	85	160	25	2.3	M6	10	7	M6	6	65											
7.5	40	0.265	300-027-122															185	100	180	195	75	80	180	25	2.3	10	M6	8	75
11	60	0.18	300-027-123																											
15	80	0.13	300-027-124																											
18.5	90	0.12	300-027-125																											

400 V Class

Max. Applicable Motor Output kW	Current Value A	Inductance mH	Code No.	Drawing	Dimensions in mm												Approx. Mass kg	Loss W												
					A	B	B1	C	D	E	F	H	I	J	K	L			M											
0.4	1.3	18	X002561	1	120	71		120	40	50	105	20	2.3		10.5		M4	2.5	15											
0.75	2.5	8.4	X002562		130	88		130	50	70	130	22	3.2		9	7		3	25											
1.5	5	4.2	X002563		2	165	105	175	155	75	85	160	25	2.3	M6	10	7	M4	4	50										
2.2	7.5	3.6	X002564																98	80	5	50								
3.7	10	2.2	X002500																90	70	5	50								
5.5	15	1.42	X002501	2	185	100	170	185	75	80	180	25	2.3	M6	10	7	M5	6	65											
7.5	20	1.06	300-027-126															185	100	170	185	75	80	180	25	2.3	10	7	8	90
11	30	0.7	300-027-127																											
15	40	0.53	300-027-128																											
18.5	50	0.42	300-027-129																											

Dimensions in mm

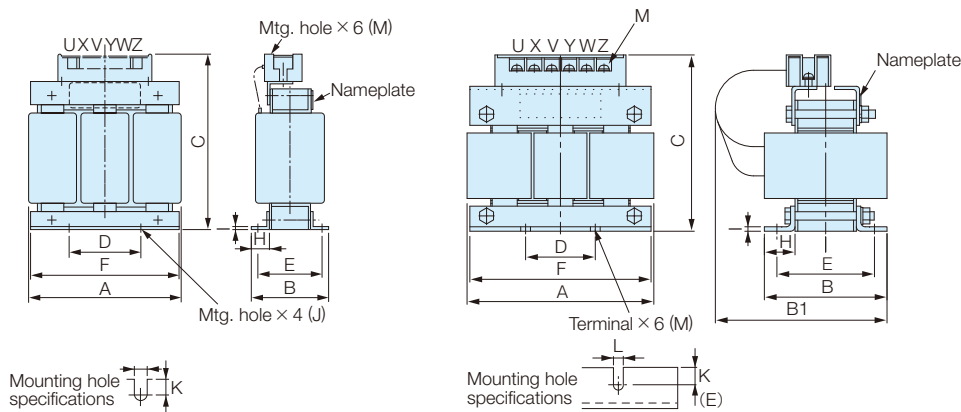

Drawing 1

Drawing 2

VS Operator

Standard Steel Plate Type

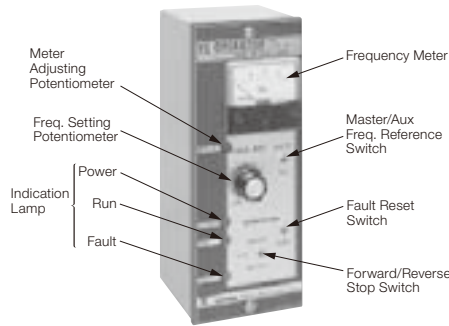

Product Series

Model JVOP	Code No.	Frequency Meter Specifications
JVOP-96 · ①	JVOP-96P1	DCF-6 A 3 V 1 mA 75 Hz
JVOP-96 · ②	JVOP-96P2	DCF-6 A 3 V 1 mA 150 Hz
JVOP-96 · ③	JVOP-96P3	DCF-6 A 3 V 1 mA 220 Hz

Dimensions in mm

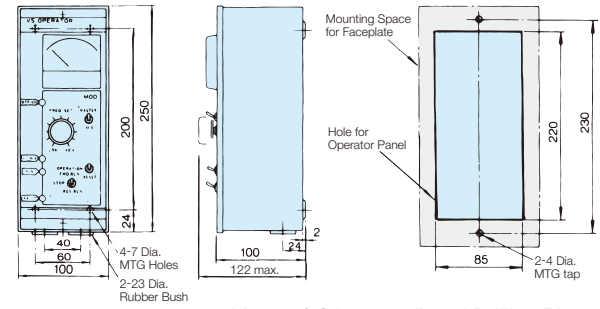

Mass : 1.8 kg Panel Drilling Plan

Small Plastic Type

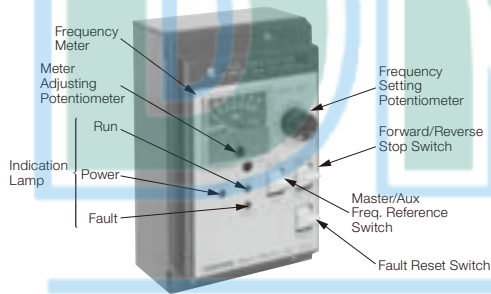

Product Series

Model JVOP	Code No.	Frequency Meter Specifications
JVOP-95 · ①	JVOP-95P1	TRM-45 3 V 1 mA 60/120 Hz
JVOP-95 · ②	JVOP-95P2	TRM-45 3 V 1 mA 90/180 Hz

Dimensions in mm

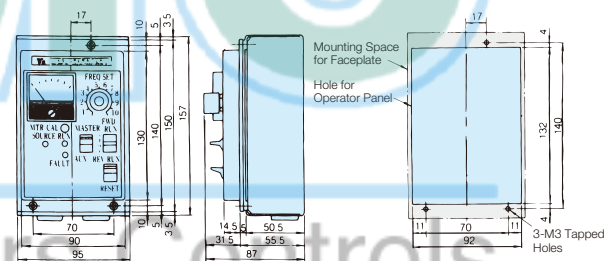

Mass : 0.8 kg Panel Drilling Plan

Digital Operator

LCD Monitor
(Model JVOP-160)
Attached as Standard



LED Monitor
(Model JVOP-161)



Digital Operator Extension Cable



Model	Code No.
WV001(1 m)	WV001
WV003(3 m)	WV003

Note: Never use this cable for connecting the drive to a PC. Doing so may damage the PC.

PC Cable

Model	Code No.
WV103	WV103

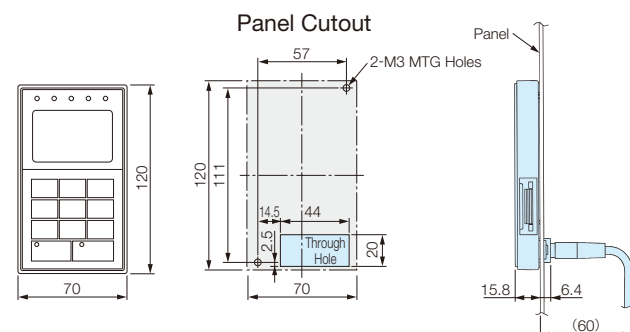

Frequency Meter/Ammeter (Model DCF-6A*, 3 V 1 mA full-scale)

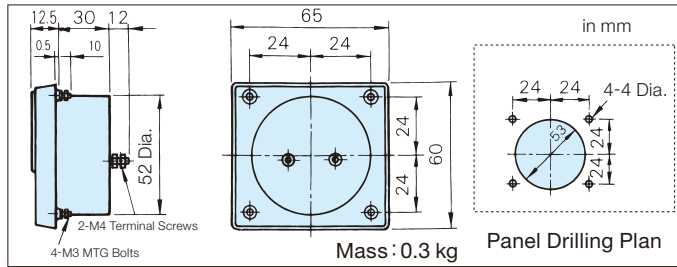
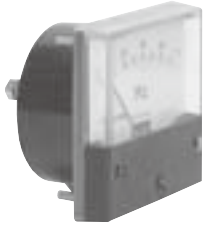

Scale

75 Hz full-scale:
Code No. FM000065
60/120 Hz full-scale:
Code No. FM000085

Note: For scale of ammeter, contact your Yaskawa representative.

* DCF-6A is 3 V, 1 mA, 3 k Ω . For Varispeed G7 multi-function analog monitor output, set frequency meter adjusting potentiometer or constant H4-02, -05 (analog monitor output gain) within the range of 0 to 3 V (initial setting is 0 to 10 V).

Potentiometer

(Attach to Inverter terminal)



- 2 k Ω for frequency reference control
- 20 k Ω for scale adjusting

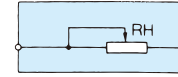

Resistance	Code No.
2 k Ω	ETX 3270
20 k Ω	ETX 3120

Mass : 20 g

Frequency Setting Potentiometer

(Model RV30YN20S, 2 k Ω Code No. RH000739)

Adjusts motor frequency through use of frequency setting knob located over the potentiometer.

Frequency Meter Adjusting Potentiometer (Model RV30YN20S 20 k Ω)

Corrects frequency meter reading.

Code No. RH000850

Frequency Setting Knob (Type CM-3S)

(Type CM-3S)

Used to adjust potentiometer frequency setting.

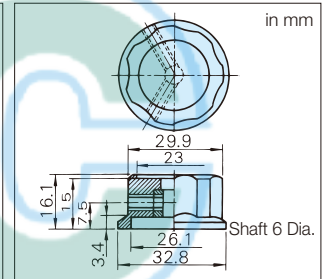
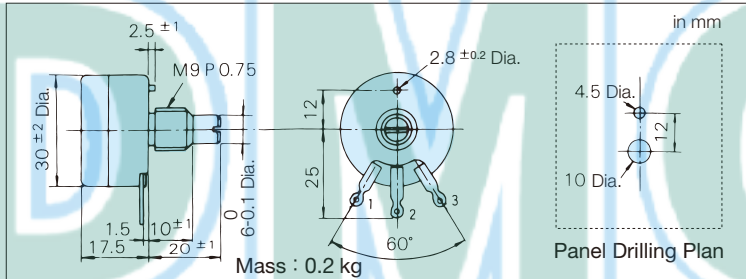
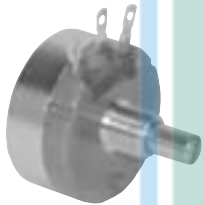

Output Voltmeter (Model SCF-12NH Rectification Type Class 2.5)

200 V Class: 300 V Full-scale (Code No. VM000481)

400 V Class: 600 V Full-scale (Output Voltmeter: Code No. VM000502
Transformer for Instrument: Code No. PT000084)

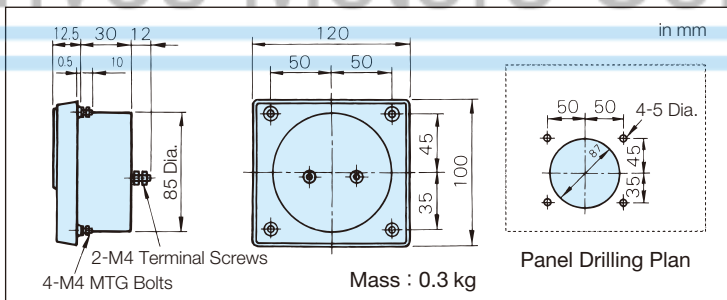

Scale Plate

(Code No. NPJT41561-1)

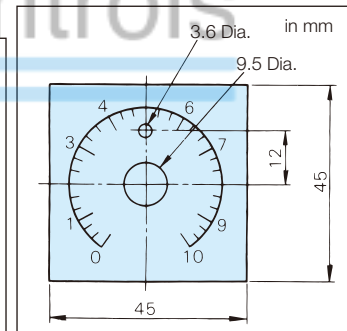

Potential Transformer (Model UPN-B)

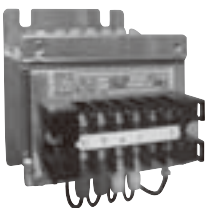

Model	Code No.
600 V Transformer for Instrument UPN-B 440 V/110 V (400/100 V)	100-011-486

Note: For use with a standard voltage regulator.
A standard voltage regulator may not match the drive output voltage. Select a regulator specifically designed for the drive output (100-011-486), or a voltmeter that does not use a transformer and offers direct read out.

Dimensions in mm

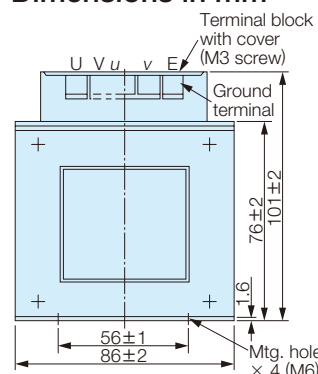

Insulation cap
Red: Drive input
Blue: Drive output

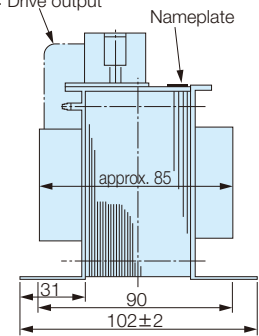

Mass : 2.2 kg

Isolator (Insulation Type DC Transmission Converter)



Performance

- | | | | |
|---------------------------------|--|---------------------------|--|
| (1) Allowance | ±0.25% of output span
(Ambient temp.: 23 °C) | (6) Response Time | 0.5 sec. or less (Time to settle to ±1% of final steady value) |
| (2) Temperature Influence | With ±0.25% of output span
(The value at ±10 °C of ambient temp.) | (7) Withstand Voltage | 2000 VAC for one min.
(between each terminal of input, output, power supply, and enclosure) |
| (3) Aux. Power Supply Influence | With ±0.1% of output span
(The value at ±10% of aux. power supply.) | (8) Insulation Resistance | 20 M.Ω and above (by 500 VDC megger).
(between each terminal of input, output, power supply, and enclosure) |
| (4) Load Resistance Influence | With ±0.05% of output span
(In the range of load resistance) | | |
| (5) Output Ripple | With ±0.5% P-P of output span | | |

Wiring Connections

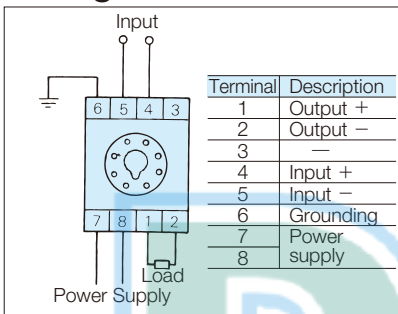

Product Line

Model	Input Signal	Output Signal	Power Supply	Code No.
DGP2-4-4	0 to 10 V	0 to 10 V	100 VAC	CON000019.25
DGP2-4-8	0 to 10 V	4 to 20 mA	100 VAC	CON000019.26
DGP2-8-4	4 to 20 mA	0 to 10 V	100 VAC	CON000019.35
DGP2-3-4	0 to 5 V	0 to 10 V	100 VAC	CON000019.15
DGP3-4-4	0 to 10 V	0 to 10 V	200 VAC	CON000020.25
DGP3-4-8	0 to 10 V	4 to 20 mA	200 VAC	CON000020.26
DGP3-8-4	4 to 20 mA	0 to 10 V	200 VAC	CON000020.35
DGP3-3-4	0 to 5 V	0 to 10 V	200 VAC	CON000020.15

Cable Length

- 4 to 20 mA : Within 100 m
- 0 to 10 V : Within 50 m

Mass

- Isolator : 350 g
- Socket : 60 g

Dimensions in mm

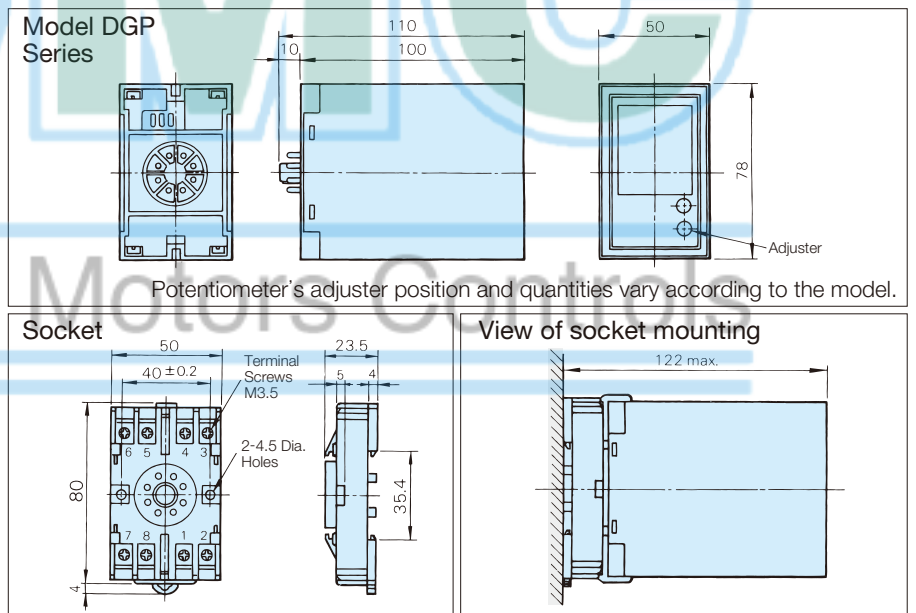

Recovery Unit for Momentary Power Loss (Applicable to models of 0.4 to 7.5 kW (200 V/400 V Class))

Use this unit for 7.5 kW or less to extend the Inverter's power loss ride-through ability to 2 seconds.*

- 200 V Class: P0010, Code No. P0010
- 400 V Class: P0020, Code No. P0020

● Connection with Inverter

● Dimensions in mm





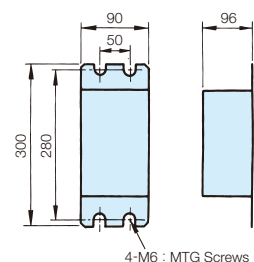
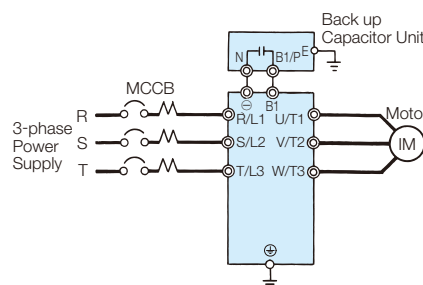





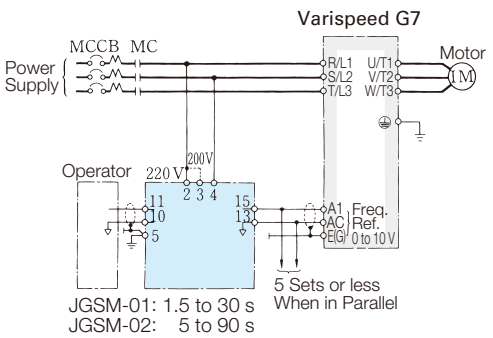

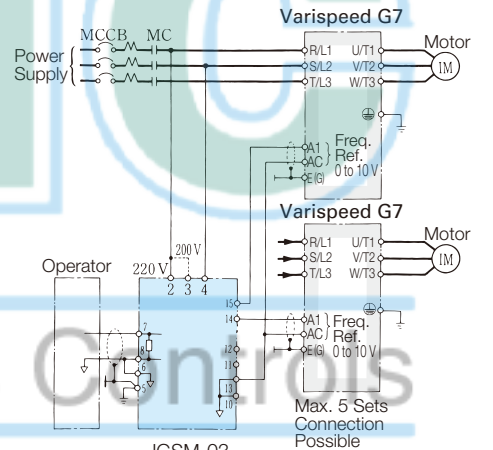

Mass : 2 kg

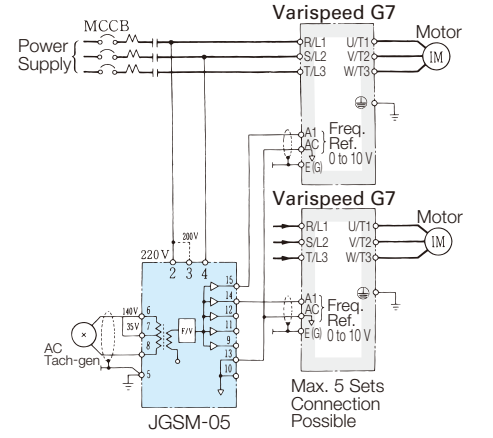



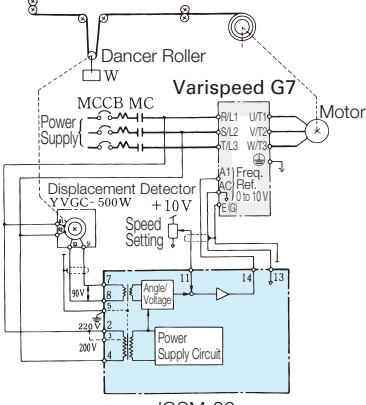
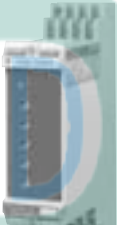
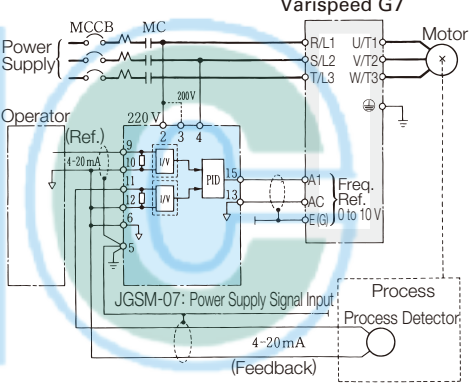

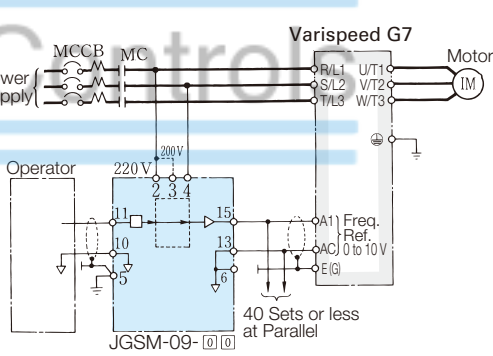

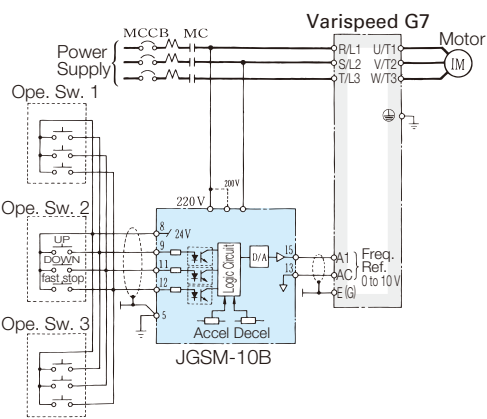

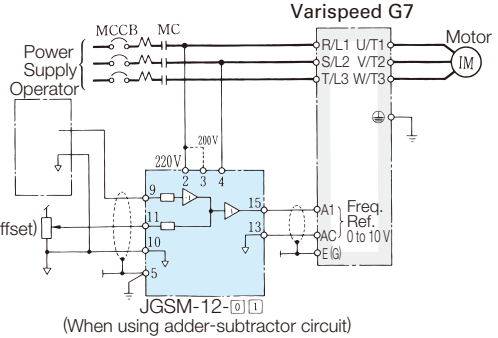

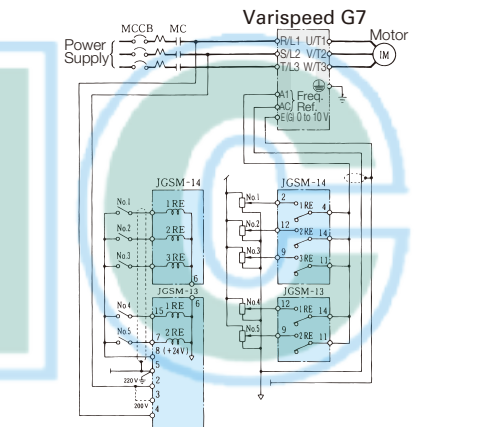

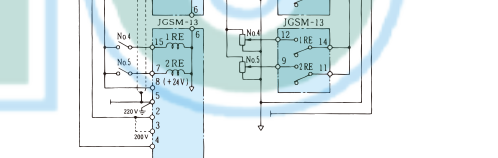
* When this unit is not used, the Inverter's power loss ride-through ability is 0.1 to 1 second.

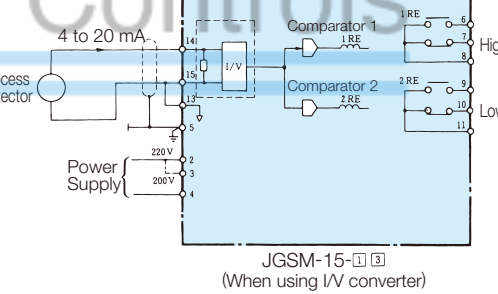
VS System Model (Power Supply Capacity 6 VA or less)

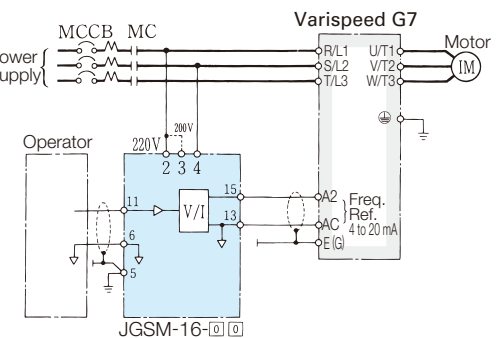
Name (Model)	Appearance	Function	Application
Soft Starter A (JGSM-01) Soft Starter B (JGSM-02)		Provides smooth changes in speed during start, stop, and when sudden changes in the speed reference would otherwise impact the load. Includes independent accel/decel time settings, fast stopping, zero speed detection, an output signal during speed changes, and polarity reversing output features. Acceleration and deceleration time setting ranges: Soft Starter A: 1.5 to 30 s Soft Starter B: 5 to 90 s	 Varispeed G7 MCCB MC Power Supply Operator 220 V 200V JGSM-01: 1.5 to 30 s JGSM-02: 5 to 90 s 5 Sets or less When in Parallel
Ratio Setter A (JGSM-03)		Converts the current signal 4 to 20 mA to a voltage signal 0 to 10 V. Allows the user to set up to five ratios and biases.	 Varispeed G7 MCCB MC Power Supply Operator 220 V 200 V JGSM-03 JGSM-04 JGSM-17 Max. 5 Sets Connection Possible
Ratio Setter B (JGSM-04)		Converts the frequency signal 0 to 2 kHz to a voltage signal 0 to 10 V. Allows the user to set up to five ratios and biases.	
Ratio Setter C (JGSM-17)		Converts a 200 Vac signal, a 30 Vac tachogenerator signal, or a 10 Vdc signal to DC for use as the speed reference. Allows the user to set up to five ratios and biases.	
Follower Ratio Setter (JGSM-05)		Converts a frequency signal from a tachogenerator for voltage input. Allows the user to set up to five ratios and biases.	 Varispeed G7 MCCB MC Power Supply Operator AC Tach-gen 220 V 200 V Max. 5 Sets Connection Possible

Name (Model)	Appearance	Function	Application
Position Controller (JGSM-06)		<p>Performs synchronous rectification on the self-synchronizing signal built into the displacement detector (YVGC-500W*1), then converts that signal to DC voltage proportional to the rotational angle.</p> <p>Equipped with a signal mixing function to extract the deviation signal from the reference signal.</p>	
PID Controller (JGSM-07)		<p>Independently sets ratio gain, integral, and differential time for the simple process control. Integral reset, stepless operation, and wind-up functions are available.</p>	
Pre-amplifier (JGSM-09-□□□□)*2		<p>Amplifies the power of the DC voltage signal and has a sign inversion output as an auxiliary output. A snap-in module (JZSP-11 to 16*1) can be added to make available the functions of that module.</p>	
UP/DOWN Setter (JGSM-10B)		<p>Lowes or raises the reference voltage by executing the "UP" or "DOWN" command remotely or from several locations.</p>	

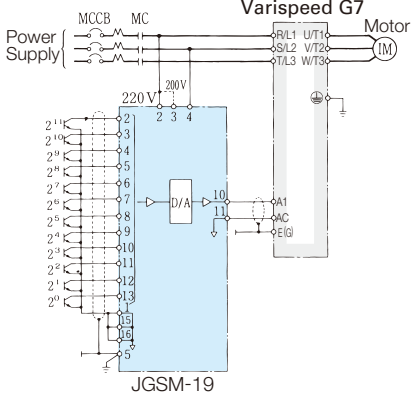
Name (Model)	Appearance	Function	Application
Operational Amplifier (JGSM-12-□□)*3		Contains two IC operational amplifier circuits. Various operation circuits can be configured by connecting various operational impedances.	 <p>(When using adder-subtractor circuit)</p>
Signal Selector A (JGSM-13)		Contains two form C contact relay circuits and a power circuit. Used as a changeover circuit of control signals.	
Signal Selector B (JGSM-14)		Contains three form C contact relay circuits. Used as a changeover circuit of control signals. Power is supplied from JGSM-13.	
Comparator (JGSM-15-□□)*2		Detects signal levels for DC voltage, current, AC tachogenerator, or frequency reference and compares them with two preset levels. The snap-in module is used to drive relays and output contact signals.	 <p>(When using I/V converter)</p>
V/I Converter (JGSM-16-□□)*2		Converts a DC voltage signal into a 4 to 20 mA current signal typically used in instrumentation systems. A snap-in module can also be added to convert the frequency signal or AC tachogenerator signal to a current signal.	

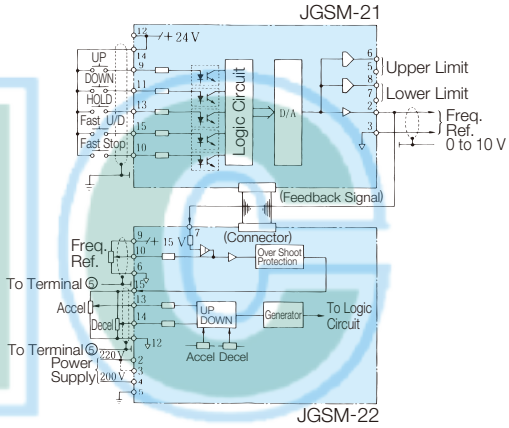
Name (Model)	Appearance	Function	Application
D/A Converter (JGSM-18) (JGSM-19)		Converts BCD 3-digit or 12 bits binary digital signals to 0 to ± 10 V analog signals with high accuracy. Model JGSM-18: BCD 3-digit input type Model JGSM-19: 12 bits binary type	
Static Potentiometer (D/A Converter:) (Controller:) (JGSM-21) (JGSM-22)		In addition to the functions of model JGSM-10B (remote setting device), wide application is offered through the command value maintenance function at power failure, the variable acceleration/deceleration function that allows external setting times, and the analog tracking function. The two system modules must always be used together to configure the static potentiometer.	

*1: Offered as a standard Yaskawa product.

*2: [] shows the model number of VS snap-in function modules.

*3: [] indicates impedance class.

Note: Both 200 V/220 V at 50 Hz/60 Hz are available as standard models. Use a transformer for other power supplies with a capacity of 6 VA or less.

Drives Motors Controls

■ VS System Module Dimensions in mm

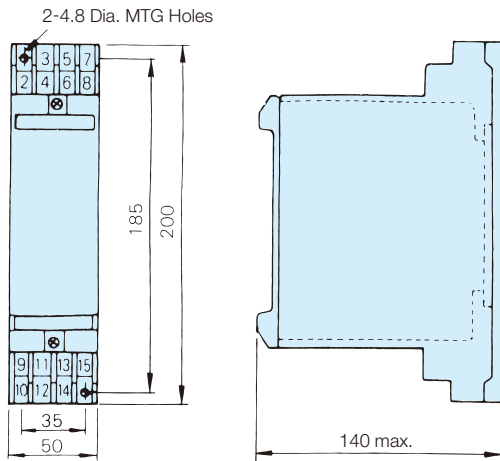

Mass : 0.8 kg

■ VS Snap-in Module List

Application	Name	Model
Short-circuit of mounting connector of VS snap-in module	Short-circuit PC board	JZSP-00
Buffer accel/decel operation	Soft starter	JZSP-12
Conversion of the current signal 4 to 20 mA, such as for process adjusting meters, to a voltage signal of 0 to 10 V.	I/V converter	JZSP-13
Conversion of the frequency signal 0 to 2 kHz to a voltage signal 0 to 10 V.	F/V converter	JZSP-14
Sequence operation with main unit	Tachogenerator follower	JZSP-15
Adding/subtracting operation of each signal	Signal mixer	JZSP-16[]
		JZSP-16-01
		JZSP-16-02
		JZSP-16-03

Application of Inverter

Selection

Setting Reactor

Use a DC reactor or AC reactor (option) on the Inverter input side when the Inverter is connected directly to a large capacity power transformer (600 kVA and more within 10 m distance) or when a power factor improvement capacitor is switched. Otherwise excess peak current may occur in the power feed circuit and the converter section may be damaged. DC reactor is built in 18.5 to 110 kW, 200 V class Inverters and 18.5 to 300 kW, 400 V class Inverters. An AC reactor is also required when a thyristor converter such as a DC drive is connected to the same power system.

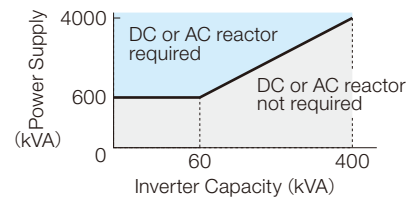

Inverter Capacity

Make sure that the motor's rated current is less than the drive's output current. When running a specialized motor or more than one motor in parallel from a single drive, the capacity of the drive should be larger than 1.1 times of the total motor rated current.

Initial Torque

The starting and accelerating characteristics of the motor driven by an Inverter are restricted by the overload current ratings of the Inverter. Compared to running with commercial power supply, lower torque output should be expected. If high starting torque is required, use an Inverter of higher capacity or increase the capacities of both the motor and the Inverter.

Emergency Stop

When an error occurs, a protective circuit is activated and the Inverter output is turned OFF. However, the motor cannot be stopped immediately. Use a mechanical brake and hold the equipment for a fast stop if necessary.

Options

Terminals B1, B2, ⊖, ⊕1, ⊕2, ⊕3 are for Yaskawa options. Do not connect equipment other than Yaskawa options.

Installation

Installation in Enclosures

Either install the Inverter in a clean location not subject to oil mist, airborne matter, dust, and other contaminants, or install the Inverter in a completely enclosed panel. Provide cooling measures and sufficient panel space so that the temperature surrounding the Inverter does not go beyond the allowable temperature. Do not install the Inverter on wood or other combustible materials. If the Inverter must be used in an area where it is subjected to oil mist, corrosive gas, and excessive vibration, protective designs are available. Contact Yaskawa for details.

Installation Direction

Install the Inverter on a wall with the longer side in the vertical position.

Installation of Bypass Circuit

If the fuse blows or the molded-case circuit breaker trips, check the selection of cables and peripheral devices and identify the cause.

If the cause cannot be identified, do not turn ON the power supply or operate the device.

Instead, contact your Yaskawa representative.

In the event of an Inverter failure when the motor will be directly driven by a commercial power supply, install the bypass circuit shown in the diagram to the right. If this bypass circuit is not installed, remove the Inverter and then

connect the motor to a commercial power supply. (In other words, after disconnecting the cables connected to the main circuit terminals, such as main circuit power supply input terminals R/L1, S/L2, and T/L3 and Inverter output terminals U/T1, V/T2, and W/T3, connect the motor to a commercial power supply.)

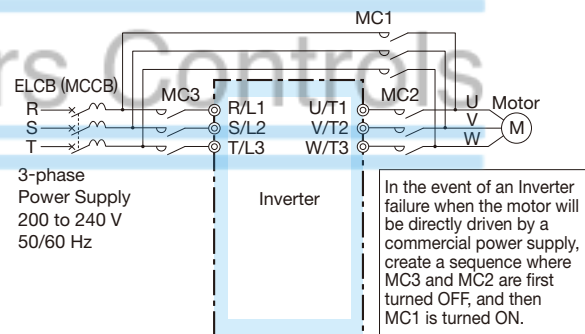

Setting

Upper Limits

The Inverter can be driven at an output frequency of up to 400 Hz with the digital operator. Setting errors may create a dangerous situation. Set the upper limit with the upper limit frequency setting function.

(Maximum output frequency in external input signal operation is preset to 60 Hz at the factory.)

DC Injection Braking

Large DC injection braking operating currents and times may cause motor overheating.

Accel/Decel Times

The motor's acceleration and deceleration times are determined by the torque generated by the motor, the load torque, and the load's inertial moment ($GD^2/4$). If the stall prevention functions are activated during acceleration or deceleration, increase the acceleration or deceleration time. The stall prevention functions will increase the acceleration or deceleration time by the amount of time the stall prevention function is active.

To reduce the acceleration or deceleration times, increase the capacity of the motor and Inverter.

Handling

- **Wiring Check**

Applying power to Inverter output terminals U/T1, V/T2, or W/T3 will damage the Inverter. DOUBLE CHECK WIRING AND SEQUENCE BEFORE TURNING THE POWER ON.
Make sure there are no short circuits on the control terminals (+V, -V, AC, etc.), as this could damage the Inverter.
- **Magnetic Contactor Installation**

Do not start and stop operation frequently with a magnetic contactor installed on the power supply line. Doing so can cause the Inverter to malfunction. Do not turn the Inverter ON and OFF with a magnetic contactor more than one time every 30 minutes.
- **Maintenance and Inspections**

After turning power to the Inverter OFF, electric charges in the internal capacitors are retained temporarily. Wait until the charge LED goes off before touching the inside of the Inverter. The voltage remaining in the capacitor may cause electric shock.
- **Wiring**

Use round pressure terminal when wiring UL and C-UL listed Inverters. Caulking should be done by the caulking tools specified by terminal manufactures.
- **Others**

Do not subject the Inverter to halogen gases, such as fluorine, chlorine, bromine, and iodine, at any time even during transportation or installation.

Application of Peripheral Unit

- **Installing a Ground Fault Interruptor or an MCCB**

Be sure to install an MCCB or an ELCB that is recommended by Yaskawa at the power supply side of the drive to protect internal circuitry.
The type of MCCB is selected depending on the power supply power factor (power supply voltage, output frequency, load characteristics, etc.). Refer to page 73 for standard selections. Select an MCCB with a rated current that is 1.5 to 2 times higher than the rated current of the Inverter to avoid nuisance trip caused by harmonics in the drive input current. If you do not use a recommended ELCB, use one fitted for harmonic suppression measures and designed specifically for drives. A malfunction may occur due to high-frequency leakage current, so the rated current of the ELCB must be 30 mA or higher per drive unit. If a malfunction occurs in an ELCB without any countermeasures, reduce the carrier frequency of the drive, replace the ELCB with one that has countermeasures against high frequency, or use an ELCB which has a rated current of 200 mA or higher per drive unit.
Select an MCCB or an ELCB with a rated capacity greater than the short-circuit current for the power supply. If the rated breaking capacity of the ELCB or MCCB is insufficient because the capacity of the power supply transformer is too large, use a fuse or other type of protection together with the ELCB or MCCB to protect the wiring from a power supply short-circuit current.
- **Use of Power Supply Side Magnetic Contactor**

Use a magnetic contactor (MC) to ensure that power to the drive can be completely shut off when necessary. The MC should be wired so that it opens when a fault output terminal is triggered. Even though an MC is designed to switch following a momentary power loss, frequent MC use can damage other components. Avoid switching the MC more than once every 30 minutes. The MC will not be activated after a momentary power loss if using the operator keypad to run the drive. This is because the drive is unable to restart automatically when set for LOCAL.
Although the drive can be stopped by using an MC installed on the power supply side, the drive cannot stop the motor in a controlled fashion, and it will simply coast to stop. If a braking resistor or dynamic braking unit has been installed, be sure to set up a sequence that opens the MC with a thermal protector switch connected to the braking resistor device.

■ **Use of Motor Side Magnetic Contactor**

Never turn the magnetic contactor ON or OFF during operation when the contactor is connected between the Inverter and motor. Starting a motor with the Inverter running will cause large surge currents and the Inverter overcurrent protector to trigger. If an MC is used for switching to commercial power supply, switch MC after the Inverter and the motor stop. To switch during motor rotation, use the speed search function. (See P40.) Use an MC with delayed release if momentary power loss is a concern.

■ **Motor Thermal Over Load Relay Installation**

Although the drive comes with built in electrothermal protection to prevent damage from overheat, a thermal relay should be connected between the drive and each motor if running several motors from the same drive. For a multipole motor or some other type of non-standard motor, Yaskawa recommends using an external thermal relay appropriate for the motor. Be sure to disable the motor protection selection parameter (L1-01 = 0), and set the thermal relay or thermal protection value to 1.1 times the motor rated current listed on the motor nameplate.

■ **Power-factor Improvement (Elimination of Phase Advance Capacitor)**

Install a DC reactor or an AC reactor on the power supply side of the Inverter to improve the power factor. DC reactor is built in 18.5 to 110 kW, 200 V class Inverters and 18.5 to 300 kW, 400 V class Inverters. Power-factor improvement capacitor or surge suppressors on the Inverter output side will be damaged by the harmonic component in the Inverter output. Also, the overcurrent caused in the Inverter output will trigger the overcurrent protection. To avoid this, do not use capacitors or surge suppressors in the Inverter's output.

■ **Radio Frequency Interference**

Because the Inverter input and output (main circuit) contains a higher harmonics component, it may emit RFI noise to communication equipment (AM radio, etc.) near the Inverter. Use a noise filter to decrease the noise. Use of a metallic conduit between the Inverter and motor or grounding the conduit is also effective.

■ **Wire Thickness and Cable Length**

If a long cable is used between the Inverter and a motor (especially when low frequency is output), motor torque decreases because of voltage drop in the cable. Use sufficiently thick wire.

When a digital operator is to be installed separately from the Inverter, use the Yaskawa remote interface and special connection cable (option). For remote control with analog signals, connect the operating pot or operating signal terminal to the Inverter within 50 m.

The cable must be routed separately from power circuits (main circuit and relay sequence circuit) so that it is not subjected to inductive interference by other equipment. If frequencies are set not only from the digital operator but also with external frequency controller, use twisted-pair shielded wire as shown in the following figure and connect the shielding to terminal E.

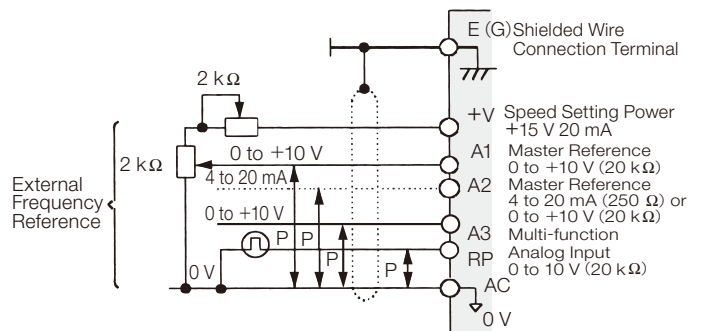

Application of Motors

Application to Existing Standard Motors

Low Speed Range

A standard motor driven by the Inverter generates slightly less power than it does when it is driven with commercial power supply.

Also, the cooling effect deteriorates in low speed range causing a motor temperature to rise. Therefore, reduce load torque in the low speed range. Allowable load characteristics of Yaskawa's standard motor are shown in the figure. If 100% continuous torque is required in the low speed range, use an Inverter duty motor.

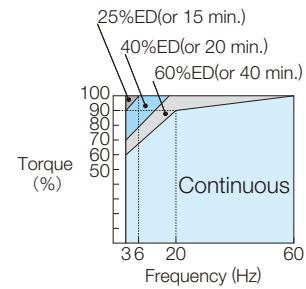

Allowable Load Characteristics of Yaskawa's Standard Motor

Insulation Withstand Voltage

Because of the 3-level control method in the Varispeed G7 series, you need not worry about the insulation in the motor. Special care is required if older motors with deteriorated insulation are used. Contact your Yaskawa representative for details.

High Speed Operation

Problems may occur with the dynamic balance and the motor bearings durability in applications operating at over 60 Hz. Contact Yaskawa for consultation.

Torque Characteristics

Motor torque characteristics vary when the motor is driven by an Inverter instead of commercial power supply. Check the load torque characteristics of the equipment to be connected. (For torque characteristics of Inverter operation.)

Vibrations

The Varispeed G7 series uses a high carrier PWM to reduce motor vibration. (A constant can be set to select low-carrier PWM modulation control as well.) When the motor is operated with the Inverter, motor vibration is almost the same as when the motor is operated with a commercial power supply. Greater vibrations may occur under the following conditions:

(1) Response at resonant frequency of the mechanical system.

Special care is required if a machine which has previously been driven at a constant speed, is to be driven at varying speeds. Installation of anti-vibration rubber padding under the motor base and frequency jump control are recommended.

(2) Rotator residual imbalance should be evaluated.

Special care is required for operation at 60 Hz or higher frequencies.

(3) Subsynchronous Resonance

Subsynchronous resonance may occur in fans, blowers, turbines, and other applications with high load inertia, as well as in motors with a relatively long shaft. Yaskawa recommends using Closed Loop Vector Control for such applications.

Noise

Noise varies with the carrier frequency. At high carrier frequencies, the noise is almost the same when the motor is operated with a commercial power supply. At above rated speeds (i.e., above 60 Hz), motor noise may increase when cooling fan is operating.

Application to Special Purpose Motors

- **Pole Change Motors** Select the Inverter with a capacity exceeding the rated current of each pole. Pole change should be made after the motor stops. If a pole is changed while the motor is rotating, the regenerative overvoltage or overcurrent protection circuit is activated and the motor then coasts to a stop.
- **Submersible Motors** The rated input current of submersible motors is higher than that of standard motors. Therefore, always select an Inverter by checking its rated output current. When the distance between the motor and Inverter is long, use a cable thick enough to connect the motor and Inverter to prevent motor torque reduction.
- **Explosion-proof Motors** When an explosion-proof motor is to be used, it must be subject to an explosion-proof test in conjunction with the Inverter. This is also applicable when an existing explosion-proof motor is to be operated with the Inverter. The Inverter and pulse coupler (pulse signal repeater) are not explosion-proof and should not be located where explosive gases exist. The PG attached to flameproof type Inverter is safety explosion-proof type. Be sure to connect an exclusive pulse coupler when wiring between the PG and Inverter.
- **Geared Motors** Lubrication method and continuous rotation limit differ with manufacturers. When oil lubrication is employed, continuous operation in low speed range may cause burnout. Before operating the motor at more than 60 Hz you should consult the motor manufacturer.
- **Synchronous Motors** An Inverter drive is not suitable for synchronous motor applications with large load variations or shock because the synchronism would be easily lost and stable motor rotation would not be possible in a low-speed range. The starting current and rated current of synchronous motors is greater than that of standard motors. Contact your Yaskawa representative regarding Inverter selection. Synchronism may be lost if multiple synchronous motors are individually turned ON and OFF during group control.
- **Single-phase Motors** Single-phase motors are not suitable for variable speed operation with an Inverter. If the Inverter is applied to a motor using a capacitor stack, a high harmonic current flows and the capacitor may be damaged. For split-phase start motors and repulsion start motors, the internal centrifugal switch will not be actuated and the starting coil may burn out. Therefore, use only 3-phase motors.
- **Uras Vibrators** Uras vibrator is a vibration motor which gets power from centrifugal force by rotating unbalance weights on both ends of the shaft. When driving by Inverter, select Inverter capacity considering followings. For details, contact your Yaskawa representative.
- (1) Uras vibrator should be used at Inverter rated frequency or less.
 - (2) V/f control should be used.
 - (3) Set acceleration time 5 to 15 because load inertia of uras vibrator is 10 to 20 times of motor inertia.
Note: When the acceleration time is less than 5 s, select Inverter capacity.
Contact your Yaskawa representative for details.
 - (4) Inverter might not start due to undertorque because eccentric moment torque (static friction torque at start) is too large.
- **Motors with Brakes** Caution should be taken when using an Inverter to operate a motor with a built-in holding brake. If the brake is connected to the output side of the Inverter, it may not release at start due to low voltage levels. Use brake-equipped motors with an independent power supply. Connect the brake power supply to the Inverter primary side. When brake-equipped motors are used, the amount of noise generally increases in the low speed range.

Power Transmission Mechanism (Gear Reduction, Belt, Chain, etc.)

When gear boxes and change/reduction gears lubricated with oil are used in power transmission systems, continuous low speed operation decreases the benefits of oil lubrication function. Caution should also be taken when operating at speeds above the rated machine speed due to noise and shortened performance life.

Precautions for Repetitive Load Applications

For applications requiring repetitive loads (such as cranes, elevators, presses, washing machines), if a high current exceeding 125% of the Inverter rated current repeatedly applied, the IGBT in the Inverter is subject to heat stress and will result in a shortened life. If so, reduce the size of the load, lengthen the acceleration/deceleration time, or increase the frame size of the Inverter so that the peak current for repetitive operation is reduced to less than 125% of the Inverter's rated current. When performing a trial operation with repetitive loads, make sure that the peak repetitive current is less than 125% of the Inverter's rated current, and make the proper adjustments if necessary. As a guideline, the number of starts and stops is approximately four million times with the function for carrier frequency reduction is enabled (factory setting =1: L8-38) and a peak current of 125% (two million starts and stops at 150%). When using Flux Vector Control, the drive is rated at two million start and stop cycles with a peak current of 125% and the carrier frequency kept at its default setting (one million stop and start cycles with a peak current of 150%).

Also, if low noise is not required, reduce the Inverter carrier frequency to 2 kHz to reduce the heat stress.

Especially for use with cranes where rapid starts and stops are needed for inching, secure the motor torque and reduce Inverter current by following these recommendations when selecting an Inverter.

- For motors of 75 kW or less

The Inverter capacity must be less than 125% of the peak current. Or, increase the Inverter capacity to one or more frames greater than the motor capacity.

- For motors exceeding 75 kW or motor cable length of 100 m or longer

The Inverter capacity must be less than 125% of the peak current with the flux vector-control Inverter. Or, increase Inverter capacity to two or more frames greater than the motor capacity.

Additional technical notes on elevator applications, and Inverters specially designed for use with elevators and cranes are available. For details, contact your Yaskawa representative.

Drives Motors Controls

Inverter Capacity Selection

● Inverter Capacity Check Points

Classification	Item		Related Specification			
			Speed and Torque Characteristics	Time Ratings	Overload Capacity	Starting Torque
Load Characteristics	Load type	Friction load and weight load Liquid (viscous) load Inertia load Load with power transmission and accumulation	○			○
	Load speed and torque characteristics	Constant torque Constant output Decreasing torque Decreasing output	○		○	
	Load characteristics	Motoring Braking or overhauling load Constant load Shock load Repetitive load High-start torque Low-start torque	○	○	○	○
Operation	Continuous operation Long-time operation at medium or low speeds Short-time operation			○	○	
Rated Output	Maximum required output (instantaneous) Constant output (continuous)		○		○	
Rated min ⁻¹	Maximum min ⁻¹ Rated min ⁻¹		○			
Power Supply	Power supply transformer capacity percentage impedance Voltage fluctuations Number of phases, single phase protection Frequency				○	○
Deterioration of Load Capacity due to Age	Mechanical friction, losses in wiring				○	○
	Duty cycle modification			○		

● Inverter Capacity Required for Continuous Operation

Item	Calculation formula
Required output for the load within the allowable range	$\frac{k \times P_M}{\eta \times \cos \phi} \leq \text{Inverter capacity [kVA]}$
Motor capacity within the Inverter ratings	$k \times \sqrt{3} \times V_M \times I_M \times 10^{-3} \leq \text{Inverter capacity [kVA]}$
Current within the Inverter ratings	$k \times I_M \leq \text{Inverter rated current [A]}$

● Inverter Capacity Required for Group Drive

Item	Calculation formula (with overload capacity of 150% for 1 minute)	
	Motor acceleration of 1 minute or less	Motor acceleration of 1 minute or more
Starting requirements are within the Inverter capacity	$\frac{k \times P_M}{\eta \times \cos \phi} \{ n_T + n_S (k_S - 1) \}$ $= P_{C1} \left\{ 1 + \frac{n_S}{n_T} (k_S - 1) \right\}$ $\leq 1.5 \times \text{Inverter capacity [kVA]}$	$\frac{k \times P_M}{\eta \times \cos \phi} \{ n_T + n_S (k_S - 1) \}$ $= P_{C1} \left\{ 1 + \frac{n_S}{n_T} (k_S - 1) \right\}$ $\leq \text{Inverter capacity [kVA]}$
Current within the Inverter capacity	$k \times n_T \times I_M \left\{ 1 + \frac{n_S}{n_T} (k_S - 1) \right\}$ $\leq 1.5 \times \text{Inverter rated current [A]}$	$k \times n_T \times I_M \left\{ 1 + \frac{n_S}{n_T} (k_S - 1) \right\}$ $\leq \text{Inverter rated current [A]}$

● Inverter Capacity Required for Starting

Item	Calculation formula [$t_A < 60$ s]
Total starting capacity within the Inverter capacity	$\frac{k \times N_M}{974 \times \eta \times \cos \phi} \left(T_L + \frac{GD^2}{375} \times \frac{N_M}{t_A} \right) \leq 1.5 \times \text{Inverter capacity [kVA]}$

Formula for Calculating Motor Capacity

● Linear motion

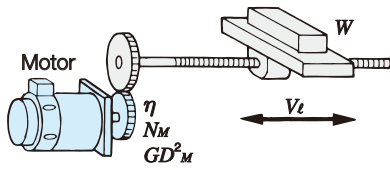

SI Units (International Units)	MKS Units (Gravimetric Units)
$T_M = \frac{60 \cdot P_M}{2\pi \cdot N_M} \times 10^3 \text{ [N} \cdot \text{m]}$	$T_M = \frac{974 \cdot P_M}{N_M} \text{ [kg} \cdot \text{m]}$
$T_L = \frac{9.8 \cdot \mu \cdot W \cdot V_l}{2\pi \cdot N_M \cdot \eta} \text{ [N} \cdot \text{m]}$	$T_L = \frac{\mu \cdot W \cdot V_l}{2\pi \cdot N_M \cdot \eta} \text{ [kg} \cdot \text{m]}$
$P_o = \frac{9.8 \cdot \mu \cdot W \cdot V_l}{60 \cdot \eta} \times 10^{-3} \text{ [kW]}$	$P_o = \frac{\mu \cdot W \cdot V_l}{6120 \cdot \eta} \text{ [kW]}$
$T_A = \frac{2\pi}{60} \cdot \frac{(J_M + J_L) N_M}{t_a} + T_L \text{ [N} \cdot \text{m]}$	$T_A = \frac{(GD_M^2 + GD_L^2) N_M}{375 \cdot t_a} + T_L \text{ [kg} \cdot \text{m]}$
$T_B = \frac{2\pi}{60} \cdot \frac{(J_M + J_L) N_M}{t_d} - T_L \text{ [N} \cdot \text{m]}$	$T_B = \frac{(GD_M^2 + GD_L^2) N_M}{375 \cdot t_d} - T_L \text{ [kg} \cdot \text{m]}$
$J_L = \left(\frac{N_l}{N_M}\right)^2 \cdot J_l \text{ [kg} \cdot \text{m}^2]$	$GD_L^2 = \left(\frac{N_l}{N_M}\right)^2 \cdot GD_l^2 \text{ [kg} \cdot \text{m}^2]$
$J_L = \frac{1}{4} W \left(\frac{V_l}{\pi \cdot N_M}\right)^2$	$GD_L^2 = W \left(\frac{V_l}{\pi \cdot N_M}\right)^2$
$= \frac{1}{4} GD_L^2$	$= W \cdot 0.1013 \cdot \left(\frac{V_l}{N_M}\right)^2$

● Rotary motion

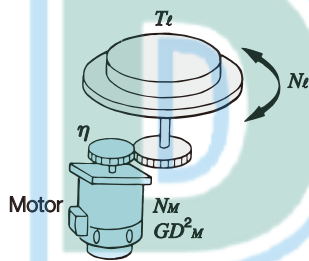

SI Units (International Units)	MKS Units (Gravimetric Units)
$T_M = \frac{60 \cdot P_M}{2\pi \cdot N_M} \times 10^3 \text{ [N} \cdot \text{m]}$	$T_M = \frac{974 \cdot P_M}{N_M} \text{ [kg} \cdot \text{m]}$
$T_L = \frac{N_l}{N_M \cdot \eta} T_l \text{ [N} \cdot \text{m]}$	$T_L = \frac{N_l}{N_M \cdot \eta} T_l \text{ [kg} \cdot \text{m]}$
$P_o = \frac{2\pi}{60} \cdot \frac{T_l \cdot N_l}{\eta} \times 10^{-3} \text{ [kW]}$	$P_o = \frac{T_l \cdot N_l}{974 \cdot \eta} \text{ [kW]}$
$t_a = \frac{2\pi}{60} \cdot \frac{(J_M + J_L) \cdot N_M}{(\alpha \cdot T_M - T_L)} \text{ [s]}$	$t_a = \frac{(GD_M^2 + GD_L^2) \cdot N_M}{375 (\alpha \cdot T_M - T_L)} \text{ [s]}$
$t_d = \frac{2\pi}{60} \cdot \frac{(J_M + J_L) \cdot N_M}{(\beta \cdot T_M + T_L)} \text{ [s]}$	$t_d = \frac{(GD_M^2 + GD_L^2) \cdot N_M}{375 (\beta \cdot T_M + T_L)} \text{ [s]}$
$J_L = \left(\frac{N_l}{N_M}\right)^2 \cdot J_l \text{ [kg} \cdot \text{m}^2]$	$GD_L^2 = \left(\frac{N_l}{N_M}\right)^2 \cdot GD_l^2 \text{ [kg} \cdot \text{m}^2]$

	(SI Units)	(MKS Units)	(SI Units)	(MKS Units)
P_o : Running power	kW	kW	η : Gear efficiency	
T_M : Motor rated torque	N · m	kg · m	μ : Friction factor	
T_L : Load torque (reflected to motor shaft)	N · m	kg · m	J_M : Motor moment of inertia	kg · m ² kg · m ²
T_l : Load torque (load axis)	N · m	kg · m	J_L : Load moment of inertia (motor axis)	kg · m ² kg · m ²
P_M : Motor rated output	kW	kW	J_l : Load moment of inertia (load axis)	kg · m ² kg · m ²
N_M : Motor rated speed	min ⁻¹	rpm	T_A : Acceleration torque	N · m kg · m
N_l : Load axis rotation speed	min ⁻¹	rpm	T_B : Braking torque	N · m kg · m
N_M : Motor axis rotation speed	min ⁻¹	rpm	t_a : Starting time	s s
V_l : Load speed	m/min	m/min	t_d : Braking time	s s
W : Mass of load	kg	kg	α : Accel torque factor (1.0 to 1.5)	
			β : Regenerative braking factor, without braking resistor (Less than 0.2) with braking resistor (0.3 to 1.5)	

Symbols (For P.102)

P_M : Motor shaft output required for the load [kW]	P_{cl} : Continuous capacity [kVA]
η : Motor efficiency (normally, approx. 0.85)	k_s : Motor starting current/motor rated current
$\cos \phi$: Motor power factor (normally, approx. 0.75)	n_T : Number of motors in parallel
V_M : Motor voltage [V]	n_s : Number of simultaneously started motors
I_M : Motor current [A] (current with commercial power supply)	GD^2 : Total (GD ²) reflected into motor shaft [kg · m ²]
k : Correction factor calculated from current distortion factor (1.0 to 1.05, depending on the PWM method.)	T_L : Load torque [N · m]
N_M : Motor rotation speed [min ⁻¹]	t_A : Motor acceleration time

Terminology

(1) Vector Controls

Current vector: Directly controls the flux current and torque current that generates motor flux and torque.

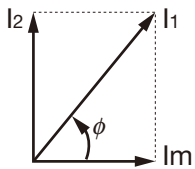

The primary current size I_1 and phase ϕ and controlled simultaneously.

Flux current $I_m = I_1 \cos \phi$

Torque current $I_2 = I_1 \sin \phi$

(Motor torque = $k I_m \cdot I_2$)

Since this control directly affects the final target torque, response is fast and precision is high.

Voltage vector: Indirectly controls the motor flux and torque via the voltage.

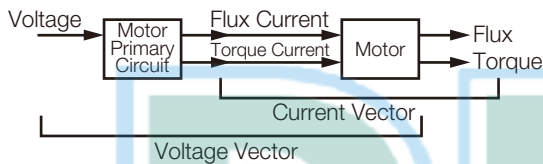

This control can be equivalent to the current vector if the primary circuit of the motor is known completely, but this is actually difficult since the temperature of the resistance also changes.

(2) Auto-tuning

Auto-tuning in the Varispeed G7, allows automatic measurement of motor constant necessary for vector control. As a result, this function changes the vector control drive not only for Yaskawa motors but for any other existing motor into an outstanding performance drive.

(3) Automatic Torque Boost

Torque boost is to compensate for the drop by primary resistance to the V/f constant voltage to supplement the decrease of the flux due to voltage drop within the motor at V/f constant control.

The V/f mode of the Varispeed G7 incorporates automatic torque boost for automatic compensation according to the load, accommodating the vector control principle.

(4) Regenerative Braking

The motor is operated as a generator, converting mechanical energy into electric energy, to generate braking force while feeding back energy to the Inverter or power supply.

The energy is fed back to the smoothing capacitor within the Inverter under regeneration status (the motor is under regenerative braking status), where its absorbed or consumed as motor loss.

(5) 12-pulse Input Control

It is a circuit method to provide a 30-degree deflected phase power supply to two converters by star delta wiring of the transformer. Fifth and seventh components of high harmonics of power supply side current can be significantly reduced.

12-pulse input control using a 3-wire transformer will reduce the effects on peripheral devices caused by a high harmonic power supply.

(6) High Harmonics

The current waveform input to the Inverter is distorted by the rectification and smoothing circuits in the Inverter. This distortion is called harmonics.

Harmonic input distortion can be minimized by attaching AC reactor to the input side or DC reactor in the main circuit.

The Varispeed G7 models of 18.5 kW or more come equipped with a built-in DC reactor. When 12-pulse input option is utilized, current distortion is much more improved.

(7) Leakage Current

Current leak always occurs when voltage is applied to any component, even if it is insulated. The PWM Inverter includes high frequency components in the output voltage, especially increasing the leak current that flows through the floating capacity of the circuit. However, leakage current of high frequency (of some kHz) presents no hazard to personnel.

(8) Noise

Noise may be generated when the Inverter operates, affecting peripheral electronic devices. The transmission mediums of this noise are air (as electric wave), induction from the main circuit wiring, power source lines, etc.

The noise that is transmitted through the air, affecting surrounding electronic devices is called radio noise. The noise can mostly be prevented by enclosing each Inverter in a metallic cabinet, ensuring adequate grounding, or separating electronic circuits from the magnetic cabinet. However, a noise filter may sometimes be required to reduce noise interference to an acceptable level.



Global Service Network



Region	Service Area	Service Location	Service Agency	Telephone/Fax
North America	U.S.A.	Chicago (HQ) Los Angeles San Francisco New Jersey Boston Ohio North Carolina	① YASKAWA AMERICA INC.	Headquarters ☎ +1-847-887-7000 FAX +1-847-887-7370
	Mexico	Mexico City	② PILLAR MEXICANA. S.A. DE C.V.	☎ +52-555-660-5553 FAX +52-555-651-5573
South America	Brazil	São Paulo	③ YASKAWA ELÉTRICO DO BRASIL LTDA.	☎ +55-11-3585-1100 FAX +55-11-3585-1187
	Colombia	Bogota	④ VARIADORES LTD.A.	☎ +57-1-795-8250
Europe	Europe, South Africa	Frankfurt	⑤ YASKAWA EUROPE GmbH	☎ +49-6196-569-300 FAX +49-6196-569-398
Asia	Japan	Tokyo, offices nationwide	⑥ YASKAWA ELECTRIC CORPORATION (Manufacturing, sales)	☎ +81-3-5402-4502 FAX +81-3-5402-4580
			⑦ YASKAWA ELECTRIC ENGINEERING CORPORATION (After-sales service)	☎ +81-3-4533-0928 FAX +81-4-2931-1830
	South Korea	Seoul	⑧ YASKAWA ELECTRIC KOREA CORPORATION (Sales)	☎ +82-2-784-7844 FAX +82-2-784-8495
			⑨ YASKAWA ENGINEERING KOREA CORPORATION (After-sales service)	☎ +82-2-3775-0337 FAX +82-2-3775-0338
	China	Beijing, Guangzhou, Shanghai	⑩ YASKAWA ELECTRIC (CHINA) CO., LTD.	☎ +86-21-5385-2200 FAX +86-21-5385-3299
	Taiwan	Taipei	⑪ YASKAWA ELECTRIC TAIWAN CORPORATION	☎ +886-2-8913-1333 FAX +886-2-8913-1513
	Singapore	Singapore	⑫ YASKAWA ELECTRIC (SINGAPORE) PTE. LTD.	☎ +65-6282-3003 FAX +65-6289-3003
	Thailand	Bangkok	⑬ YASKAWA ELECTRIC (THAILAND) CO., LTD.	☎ +66-2-017-0099 FAX +66-2-017-0090
	Vietnam	Ho Chi Minh	⑭ YASKAWA ELECTRIC VIETNAM CO., LTD.	☎ +84-8-3822-8680 FAX +84-8-3822-8780
		Hanoi		☎ +84-4-3634-3953 FAX +84-4-3654-3954
	India	Bangalore	⑮ YASKAWA INDIA PRIVATE LIMITED	☎ +91-80-4244-1900 FAX +91-80-4244-1901
	Indonesia	Jakarta	⑯ PT. YASKAWA ELECTRIC INDONESIA	☎ +62-21-2982-6470 FAX +62-21-2982-6471
Oceania	Australia	Contact to service agency in U.S.A. (①).		

Varispeed G7

DRIVE CENTER (INVERTER PLANT)

2-13-1, Nishimiyaichi, Yukuhashi, Fukuoka, 824-8511, Japan
Phone +81-930-25-2548 Fax +81-930-25-3431
<http://www.yaskawa.co.jp>

YASKAWA ELECTRIC CORPORATION

New Pier Takeshiba South Tower, 1-16-1, Kaigan, Minatoku, Tokyo, 105-6891, Japan
Phone +81-3-5402-4502 Fax +81-3-5402-4580
<http://www.yaskawa.co.jp>

YASKAWA AMERICA, INC.

2121, Norman Drive South, Waukegan, IL 60085, U.S.A.
Phone +1-800-YASKAWA (927-5292) or +1-847-887-7000 Fax +1-847-887-7310
<http://www.yaskawa.com>

YASKAWA ELÉTRICO DO BRASIL LTDA.

777, Avenida Piraporinha, Diadema, São Paulo, 09950-000, Brasil
Phone +55-11-3585-1100 Fax +55-11-3585-1187
<http://www.yaskawa.com.br>

YASKAWA EUROPE GmbH

Hauptstraße 185, 65760 Eschborn, Germany
Phone +49-6196-569-300 Fax +49-6196-569-398
<http://www.yaskawa.eu.com> E-mail: info@yaskawa.eu.com

YASKAWA ELECTRIC KOREA CORPORATION

35F, Three IFC, 10 Gukjegeumyung-ro, Yeongdeungpo-gu, Seoul, 07326, Korea
Phone +82-2-784-7844 Fax +82-2-784-8495
<http://www.yaskawa.co.kr>

YASKAWA ELECTRIC (SINGAPORE) PTE. LTD.

151, Lorong Chuan, #04-02A, New Tech Park 556741, Singapore
Phone +65-6282-3003 Fax +65-6289-3003
<http://www.yaskawa.com.sg>

YASKAWA ELECTRIC (THAILAND) CO., LTD.

59, 1st-5th Floor, Flourish Building, Soi Ratchadapisek 18, Ratchadapisek Road, Huaykwang, Bangkok 10310, Thailand
Phone +66-2-017-0099 Fax +66-2-017-0799
<http://www.yaskawa.co.th>

PT. YASKAWA ELECTRIC INDONESIA

Secure Building-Gedung B Lantai Dasar & Lantai 1 Jl. Raya Protokol Halim Perdanakusuma, Jakarta 13610, Indonesia
Phone +62-21-2982-6470 Fax +62-21-2982-6471
<http://www.yaskawa.co.id/>

YASKAWA ELETRIC VIETNAM CO., LTD HO CHI MINH OFFICE

Suite 1904A, 19th Floor Centec Tower, 72-74 Nguyen Thi Minh Khai Street, Ward 6, District 3, Ho Chi Minh City, Vietnam
Phone +84-8-3822-8680 Fax +84-8-3822-8780

YASKAWA ELETRIC VIETNAM CO., LTD HA NOI OFFICE

2nd Floor, Somerset Hoa Binh Hanoi, No. 106, Hoang Quoc Viet Street, Cau Giay District, Hanoi, Vietnam
Phone +84-4-3634-3953 Fax +84-4-3654-3954

YASKAWA ELECTRIC (CHINA) CO., LTD.

22F, One Corporate Avenue, No.222, Hubin Road, Shanghai, 200021, China
Phone +86-21-5385-2200 Fax +86-21-5385-3299
<http://www.yaskawa.com.cn>

YASKAWA ELECTRIC (CHINA) CO., LTD. BEIJING OFFICE

Room 1011, Tower W3 Oriental Plaza, No.1 East Chang An Ave.,
Dong Cheng District, Beijing, 100738, China
Phone +86-10-8518-4086 Fax +86-10-8518-4082

YASKAWA ELECTRIC TAIWAN CORPORATION

12F, No. 207, Sec. 3, Beishin Rd., Shindian Dist., New Taipei City 23143, Taiwan
Phone: +886-2-8913-1333 Fax: +886-2-8913-1513 or +886-2-8913-1519
<http://www.yaskawa.com.tw>

YASKAWA INDIA PRIVATE LIMITED

#17/A, Electronics City, Hosur Road, Bangalore, 560 100 (Karnataka), India
Phone +91-80-4244-1900 Fax +91-80-4244-1901
<http://www.yaskawaindia.in>

YASKAWA

YASKAWA ELECTRIC CORPORATION

In the event that the end user of this product is to be the military and said product is to be employed in any weapons systems or the manufacture thereof, the export will fall under the relevant regulations as stipulated in the Foreign Exchange and Foreign Trade Regulations. Therefore, be sure to follow all procedures and submit all relevant documentation according to any and all rules, regulations and laws that may apply. Specifications are subject to change without notice for ongoing product modifications and improvements.

© 2001 YASKAWA ELECTRIC CORPORATION

LITERATURE NO. KAE-S616-60I <11>-0

Published in Japan August 2017
17-3-24