

YASKAWA

Yaskawa Regenerative Energy-saving Unit Series

Power Regenerative Unit

R1000

200 V Class, 3.5 kW to 105 kW
400 V Class, 3.5 kW to 300 kW



Power Regenerative Converter

D1000

200 V Class, 5.0 kW to 130 kW
400 V Class, 5.0 kW to 630 kW



Low Harmonics
Regenerative
Matrix Converter

U1000



Use Energy Effectively!

Save Energy by Reusing Previously Wasted Energy!

Return the regenerative energy produced by your equipment to the power supply.

Power Regeneration:

Power regeneration refers to the function of returning energy that is generated by the motor to the power supply. For example, when a crane lifts a load, the motor requires energy. However, when the crane lowers the load, the weight of the load rotates the motor and generates energy. Conventionally, the generated energy is consumed as heat by the braking resistor, but this energy can be returned to the power supply and reused to save energy.

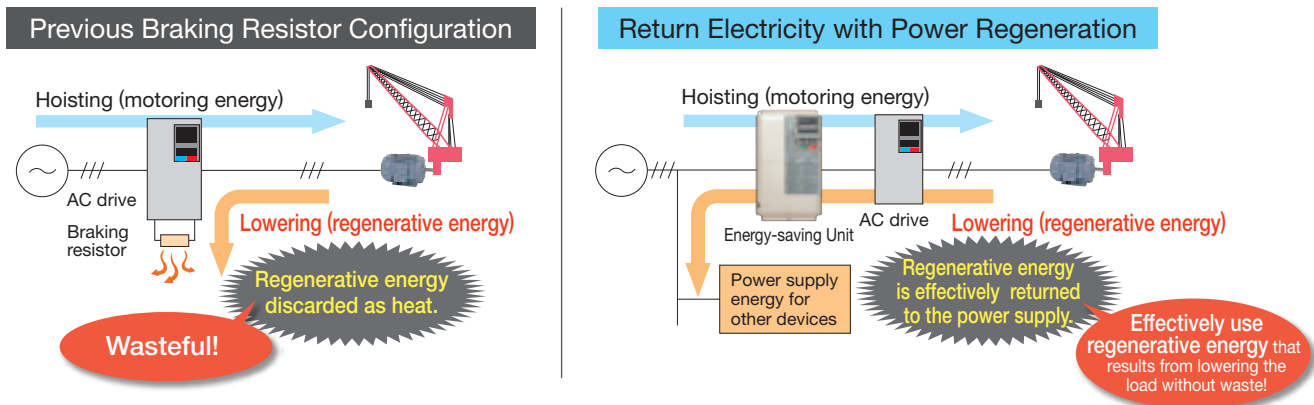

Machines Generate Energy!

Effectively use this energy to save energy!

■ Lifts, such as cranes

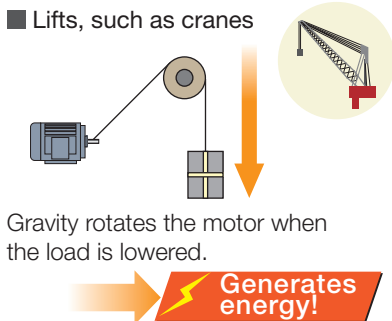

■ Horizontal conveyors, such as dollies

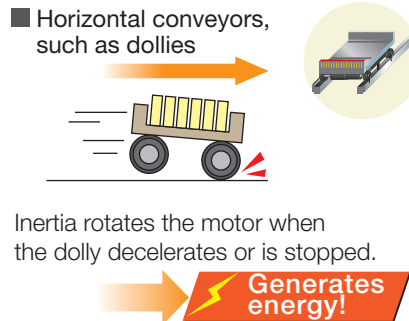

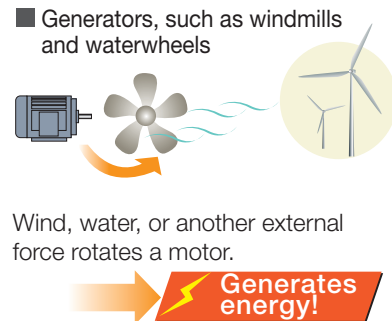

■ Generators, such as windmills and waterwheels



Applications

Model comparison: Energy-Saving Units

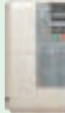
● Best ○ Good — N/A

Applicable items	Power Regenerative Unit R1000 	Power Regenerative Converter D1000 	Low Harmonics Regenerative Matrix Converter U1000 
Motor drive	—	—	● (drive function built-in)
Use power regeneration to save energy .	●	●	●
Improve the power factor .	—	●	●
Suppress power supply harmonics .	—	●	●
Reduce the capacity of power equipment .	—	●	●
Apply for multiple drives.	—	●	—
Suppress the cost of introduction .	●	○	○
Downsize control panels .	○	○	●
Simplify main circuit wiring.	○	○	●

The Elite of Complete Power Savings!

Replaces Braking Resistor



Power Regenerative Unit

R1000

More Compact and Better Braking Power

Change from previous braking resistor configuration to the R1000 unit to save energy, increase braking power, and downsize equipment.

UL US CE RoHS Compliant
Restriction of Hazardous Substances Directive

Replaces Braking Resistor and Braking Unit

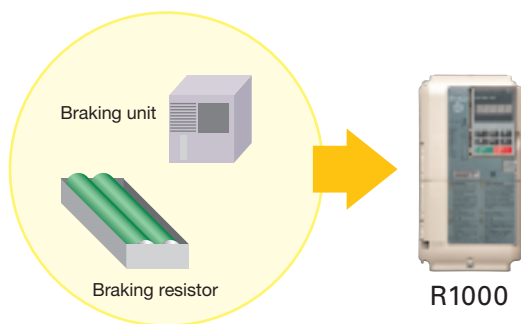

Comparison with Previous configuration

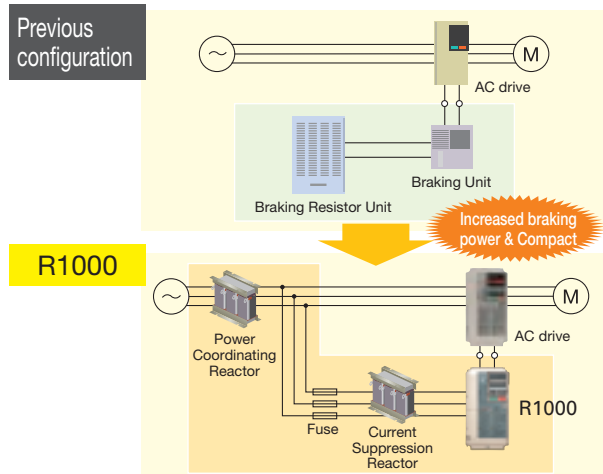

Save Electricity with Power Regeneration and More

1

Machine Downsizing

The system configuration is much smaller than for a braking resistor system so that you can save space in control panels.

Previous configuration

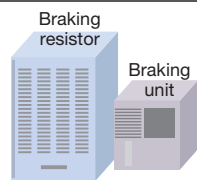

Footprint: 0.445 m²

R1000

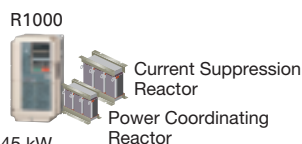

Footprint: 0.167 m²

Footprint
Approx. 1/3
(Approx. 62%
reduced)

(in-house comparison)

2

More Braking Power

The braking torque is greater than that of conventional braking resistors. More braking power is available when in continuous regenerative operation.

Previous configuration

125% (10 s)

Example for LKEB4045

R1000

150% torque (30 s)

High Braking
Torque

3

Less Heat Generation

Unlike conventional braking resistors, the unit is safe because it does not convert regenerative energy into heat.

LKEB-2015
10 Ω 3000 W

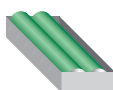

Max Heat Loss 3000 W

CIMR-RA2A03P5
200 V 3.5 kW

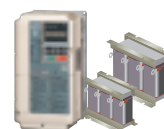

Rated Heat Loss 106 W

Total Heat Loss
Approx. 1/30



Save Electricity with Power Regeneration

Lift applications with heavy repetitive loads and regenerative power



More Braking Power

· Equipment with large brakes
· Equipment that requires frequent braking



Power Supply Unit



Power Regenerative Converter

D1000

In Pursuit of Power Quality

Achieve higher power factors and suppress harmonics for power supplies with installation to an AC drive.

UL US CE **RoHS Compliant**
Restriction of Hazardous Substances Directive

A Power Supply Unit for AC Drives and Servo Drives

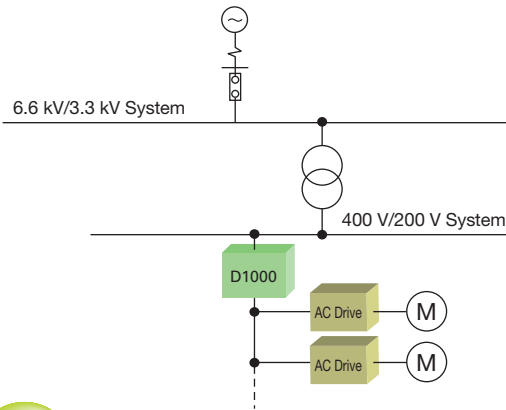

Comparison with Previous configuration

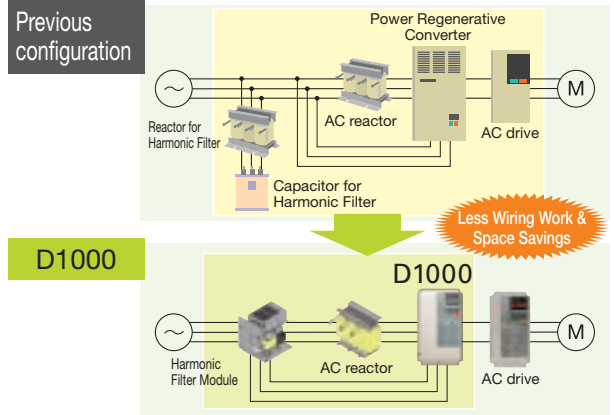

Save Electricity with Power Regeneration and More

1

No Power Supply Harmonics

There are no power supply harmonics.

■ Spectrum

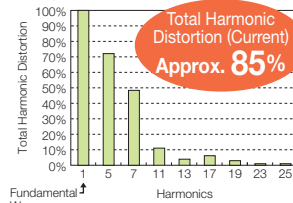

Test Conditions: Without reactor, rated load.

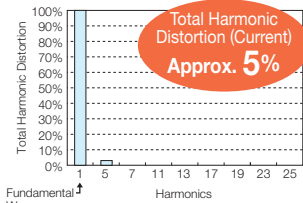

Test Conditions: One transformer, rated load, input voltage distortion is 1% or less.

2

Improved Power Factor

Power factor 1 control enables power to be used effectively and reduces the power supply capacity.

■ Input Power Supply Current Waveform Comparison

Standard Drive

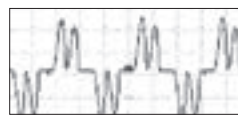

Large power supply current distortion rate.

Power factor: **Approx. 0.7**

Standard Drive with D1000

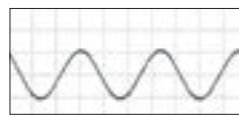

Small power supply current distortion rate.

Power factor: **Approx. 1.0** Condition: Rated load.

Power factor: **Approx. 1.0**

3

Connect Multiple Units

Stable power supply is enabled by DC links between multiple AC drives.

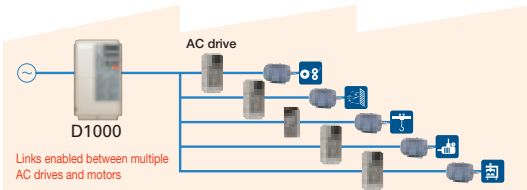

Save Electricity with Power Regeneration

- Lift applications with heavy repetitive loads and regenerative power
- Equipment with multiple axes

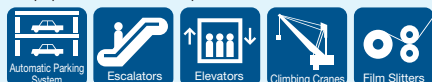

Improved Power Factors and No Power Supply Harmonics

Variable-speed applications in hospitals, schools, office buildings, etc. with strict requirements for harmonic distortion



Compact Drive



Low Harmonics Regenerative Matrix Converter

U1000

All-in-one Motor Drive

Evolved matrix converter features functions of AC drives, power regeneration, power factor improvement, and power supply harmonic suppression in one body.



RoHS Compliant
Restriction of Hazardous
Substances Directive

Next-generation motor drive surpasses the functions of AC drives

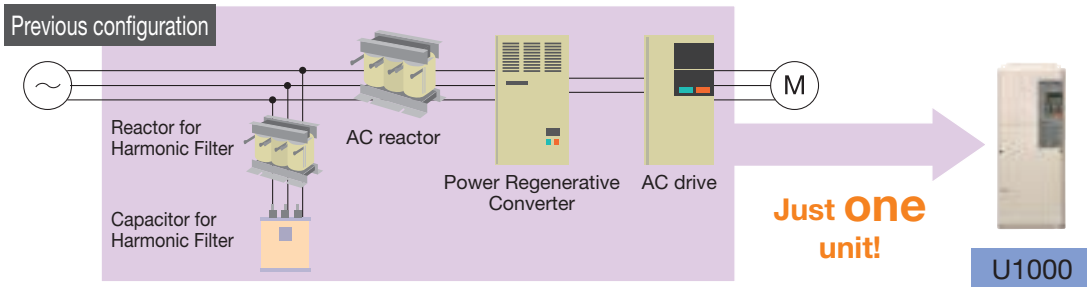

Save Electricity with Power Regeneration and More

1 Compact

The all-in-one design both reduces wiring and saves space.

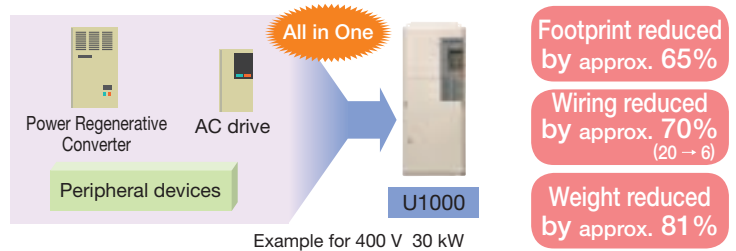

2 High Power Factor and Power Supply Harmonic Suppression

High power factor control and power supply harmonics suppression reduce the power supply capacity.

Input Power Supply Current Waveform Comparison

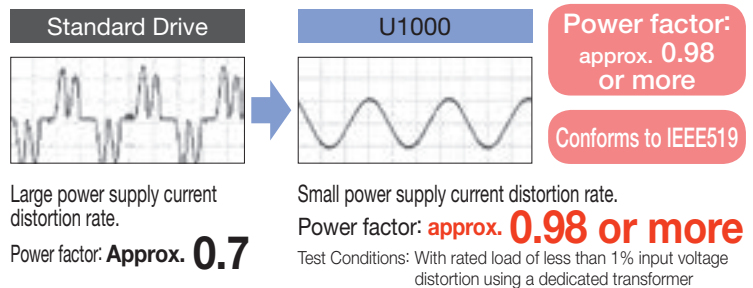

3 Greater Efficiency

There is less energy lost in comparison with previous power regeneration systems because a regenerative converter and peripheral devices are not required.

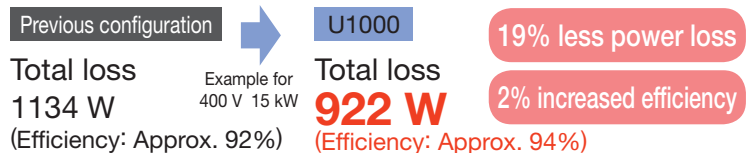

Save Electricity with Power Regeneration

Lift applications with heavy repetitive loads and regenerative power

High Power Factor and Power Supply Harmonic Suppression

·Variable-speed applications in hospitals, schools, data centers, and office buildings with strict requirements for harmonic distortion
·Power generator application



R1000 Standard Specifications

Voltage		200 V Class												400 V Class															
Model CIMR-RA		03P5	0005	0007	0010	0014	0017	0020	0028	0035	0053	0073	0105	03P5	0005	0007	0010	0014	0017	0020	0028	0035	0043	0053	0073	0105	0150	0210	0300
Rating	Regeneration Capacity kW	3.5	5	7	10	14	17	20	28	35	53	73	105	3.5	5	7	10	14	17	20	28	35	43	53	73	105	150	210	300
	Rated Output Current (DC) A	14	20	27	41	55	68	81	112	138	207	282	413	7	11	15	22	30	36	43	58	73	89	109	149	217	320	440	629
	Rated Input Current (AC) A	10	15	20	30	41	50	60	83	102	153	209	306	5	8	11	16	22	27	32	43	54	66	81	110	161	237	326	466
Input	Rated Voltage/ Rated Frequency	200 to 240 V 50/60 Hz												380 to 480 V 50/60 Hz															
	Allowable Voltage Fluctuation	-15 to +10%																											
	Allowable Power Voltage Imbalance between Phases	±2%																											
Control Characteristics	Control Method	120° excitation method																											
	Input Power Factor	0.9 minimum (for rated operation)																											
	Overload Protection	30 s at approx. 150% of rated current.																											
	Regenerative Torque	150% 30 s, 100% 25% ED 60 s, 80% continuous																											
Status Output	1 C-relay output at failures, 1 a contact output (multi-function) during operation, 2 multi-function PHC outputs selectable at alarms, 2 multi-function analog outputs selectable for analog outputs																												

R1000 Dimensions mm

Regenerative Unit

Voltage Class		200 V Class												400 V Class															
Model CIMR-RA		03P5	0005	0007	0010	0014	0017	0020	0028	0035	0053	0073	0105	03P5	0005	0007	0010	0014	0017	0020	0028	0035	0043	0053	0073	0105	0150	0210	0300
Open-Chassis (IP00)	Width (W)	140	140	140	180	180	220	220	220	275	325	450	500	140	140	140	180	180	220	220	220	275	275	325	325	450	450	500	500
	Height (H)	260	260	260	300	300	365	365	385	450	550	705	800	260	260	260	300	300	365	365	365	450	450	550	550	705	705	800	800
	Depth (D)	167	167	167	187	187	197	197	197	258	283	330	350	167	167	167	187	187	197	197	197	258	258	283	283	330	330	350	350
Enclosed Wall-Mounted (IP20/UL Type 1)	Width (W)	140	140	140	180	180	220	220	220	275	329	450	-	140	140	140	180	180	220	220	220	275	275	329	329	450	450	-	-
	Height (H)	260	260	260	300	300	365	365	385	450	730	705	-	260	260	260	300	300	365	365	365	450	450	730	730	705	705	-	-
	Depth (D)	167	167	167	187	187	197	197	197	258	283	330	-	167	167	167	187	187	197	197	197	258	258	283	283	330	330	-	-

Standard Configuration Devices

Voltage Class		200 V Class												400 V Class															
Model CIMR-RA		03P5	0005	0007	0010	0014	0017	0020	0028	0035	0053	0073	0105	03P5	0005	0007	0010	0014	0017	0020	0028	0035	0043	0053	0073	0105	0150	0210	0300
Power Coordinating Reactor	Width (A)*2	130	130	130	160	180	180	210	210	190	240	265	130	130	160	160	180	180	180	210	210	240	240	270	270	285	320	320	
	Height (C)*2	110	110	110	135	155	155	155	180	180	245	290	275	123	123	135	135	155	155	155	180	180	210	210	235	235	255	310	345
	Depth (B)*2	90	90	100	107	102	102	102	102	117	107	107	117	90	100	92	107	102	102	97	102	117	128	128	164	164	170	160	197
Current Suppression Reactor	Width (A)*2	96	96	96	120	120	120	131	131	161	161	181	96	96	96	96	120	120	120	120	131	131	161	161	181	215	215	241	
	Height (C)*2	104	104	104	95	95	95	95	110	110	130	130	155	104	104	104	104	95	95	95	95	110	110	130	130	155	170	175	215
	Depth (B)*2	63	63	63	73	73	73	73	90	90	91	101	101	63	63	63	63	73	73	73	73	90	100	91	91	101	108	118	128
Fuse	Width (A)	55	55	55	55	55	55	78	78	78	98	110	76.5	76.5	76.5	76.5	76.5	76.5	76.5	76.5	76.5	76.5	98	98	100	98	110	109	
	Height (C)	18	18	18	18	18	18	26	26	26	49	-	19	19	19	19	19	19	19	19	19	19	26	26	40	49	-	-	
	Depth (B)	12	12	12	12	12	12	20	20	20	28	20	12	12	12	12	12	12	12	12	12	12	20	20	20	28	20	30	
Fuse Holder	Width (A)	65	65	65	65	65	65	88	88	88	145	205	85	85	85	85	85	85	85	85	85	85	108	108	145	145	205	205	
	Height (C)	17.8	17.8	17.8	17.8	17.8	17.8	17.8	17.8	17.8	19	22	19.8	19.8	19.8	19.8	19.8	19.8	19.8	19.8	19.8	19.8	19.8	19.8	19	19	22	22	
	Depth (B)	26	26	26	26	26	26	33	33	33	43	85	26	26	26	26	26	26	26	26	26	26	33	33	43	43	85	85	

*1: This number indicates the voltage class (2: 200 V class, 4: 400 V class).
 *2: This value indicates the maximum dimension, including tolerance.

Note: 1 R1000 requires standard configuration devices.
 2 Refer to R1000 catalog (No. KAEPC71065605) for details.

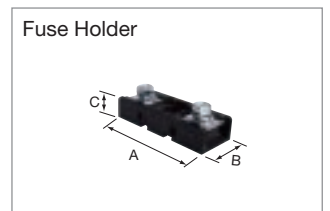
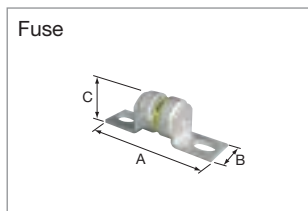
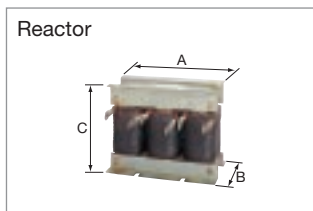
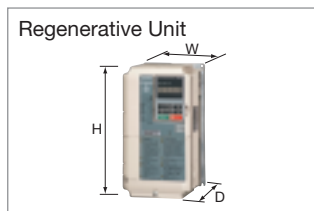

R1000/D1000 Connectable Models

AC Drives

High performance Drive
GA700

High performance vector control Drive
A1000

Compact vector control Drive
V1000

Compact V/f control Drive
J1000

Elevator Applications
L1000A

Advanced vector control
Varispeed G7

AC Servo Drives

AC Servo Drives
Σ-7 Series

AC Servo Drives
Large-Capacity
Σ-V Series

■ D1000 Standard Specifications

Voltage Class		200 V Class									400 V Class										
Model CIMR-DA*1A□□□□		0005	0010	0020	0030	0050	0065	0090	0130	0005	0010	0020	0030	0040	0060	0100	0130	0185	0270	0370	0630
Rating	Rated Output Capacity*2 kW	5	10	20	30	50	65	90	130	5	10	20	30	40	60	100	130	185	270	370	630
	Rated Output Current (DC) A	15	30	61	91	152	197	273	394	8	15	30	45	61	91	152	197	280	409	561	955
	Rated Input Current (AC) A	15	29	57	83	140	200	270	400	8	16	30	43	58	86	145	210	300	410	560	1040
	Rated Output Voltage	DC330 V									DC660 V										
Input	Rated Voltage/ Rated Frequency	200 to 240 V 50/60 Hz									380 to 480 V 50/60 Hz										
	Allowable Voltage Fluctuation	-15 to +10%																			
	Allowable Power Voltage Imbalance between Phases	±2%																			
Control Characteristics	Control Method	Sine-wave PWM control																			
	Input Power Factor	Input power factor of 0.99 minimum (for rated operation)																			
	Output Voltage Accuracy	±5%																			
	Overload Protection	Unit stops after 60 s at 150% of rated output current or after 3 s at 200% of rated output current.																			
Status Output	1 C-relay output at failures, 1 a contact output (multi-function) during operation, 2 multi-function PHC outputs selectable at alarms, 2 multi-function analog outputs selectable for analog outputs																				

■ D1000 Dimensions mm

Regenerative Converter

Voltage Class		200 V Class									400 V Class										
Model CIMR-DA*1A□□□□		0005	0010	0020	0030	0050	0065	0090	0130	0005	0010	0020	0030	0040	0060	0100	0130	0185	0270	0370	0630
Open-Chassis (IP00)	Width (W)	-	-	-	275	325	450	450	500	-	-	-	275	275	325	325	500	500	670	670	1250
	Height (H)	-	-	-	450	550	705	705	800	-	-	-	450	450	550	550	800	800	1140	1140	1380
	Depth (D)	-	-	-	258	283	330	330	350	-	-	-	258	258	283	283	350	350	370	370	370
Open-Chassis (IP20)	Width (W)	180	180	220	279	329	456	456	504	180	180	220	279	279	329	329	504	504	-	-	-
	Height (H)	300	300	365	515	730	960	960	1168	300	300	365	515	515	730	730	1168	1168	-	-	-
	Depth (D)	187	187	197	258	283	330	330	350	187	187	197	258	258	283	283	350	350	-	-	-

Standard Configuration Devices

Voltage Class		200 V Class									400 V Class										
Model CIMR-DA*1A□□□□		0005	0010	0020	0030	0050	0065	0090	0130	0005	0010	0020	0030	0040	0060	0100	0130	0185	0270	0370	0630
Harmonic Filter Module	Width (A)	209	209	232	260	290	290	290	350	209	209	232	260	260	290	290	350	350	-	-	-
	Height (C)	176	184	265	281	348	350	387	500	176	178	265	293	293	348	385	500	500	-	-	-
	Depth (B)	285	295	301	305	355	352	352	380	285	295	301	305	305	355	355	380	380	-	-	-
Input-side AC Reactor 1	Width (A)	160	205	268	268	330	320	380	445	160	206	240	265	268	330	320	385	450	510	560	560
	Height (C)	133	173	275	290	334	343	382	436	133	173	212	290	285	331	366	382	424	482	549	549
	Depth (B)	114	106	146	161	161	211	220	240	104	101	126	161	176	161	211	235	240	300	320	320
Input-side AC Reactor 2	Width (A)	-	-	-	-	-	-	-	-	-	-	-	-	-	-	-	-	-	330	385	452
	Height (C)	-	-	-	-	-	-	-	-	-	-	-	-	-	-	-	-	-	326	382	545
	Depth (B)	-	-	-	-	-	-	-	-	-	-	-	-	-	-	-	-	-	176	220	375
Reactor for Harmonic Filter	Width (A)	-	-	-	-	-	-	-	-	-	-	-	-	-	-	-	-	-	160	180	210
	Height (C)	-	-	-	-	-	-	-	-	-	-	-	-	-	-	-	-	-	135	150	190
	Depth (B)	-	-	-	-	-	-	-	-	-	-	-	-	-	-	-	-	-	104	100	102
Capacitor for Harmonic Filter	Width (A)	-	-	-	-	-	-	-	-	-	-	-	-	-	-	-	-	-	438	438	695
	Height (C)	-	-	-	-	-	-	-	-	-	-	-	-	-	-	-	-	-	502	602	582
	Depth (B)	-	-	-	-	-	-	-	-	-	-	-	-	-	-	-	-	-	128	128	128

*1: This number indicates the voltage class (2: 200 V class, 4: 400 V class).

*2: For the 200 V class, rated output capacity is calculated with an input voltage of 200 V.

For the 400 V class, values are given for an input voltage of 400 V.

Note: 1 D1000 requires standard configuration devices.

2 Refer to D1000 catalog (No. KAEP71065603) for details.

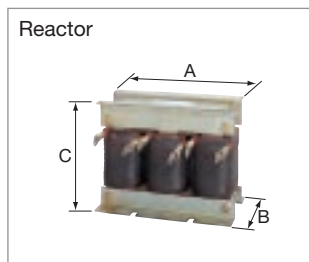
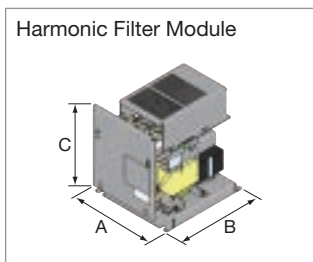
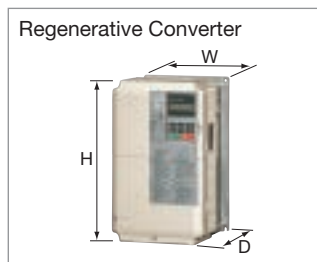

■ U1000 Standard Specifications

200 V Class

ND = Normal Duty, HD = Heavy Duty

Model	CIMR-UA: []	[]	[]	[]	[]	[]	[]	[]	[]	[]	[]	[]
Rated Input/Output	Rated Input Current	ND	25	38	49	62	74	95	118	140	175	226
		A	HD	20	25	38	49	62	74	95	118	140
	Rated Input Capacity	ND	12	17	22	28	34	43	54	64	80	103
		kVA	HD	9	12	17	22	28	34	43	54	64
Rated Output Current*1	ND	28	42	54	68	81	104	130	154	192	248	
	A	HD	22	28	42	54	68	81	104	130	154	192

400 V Class

Model	CIMR-UA: []	[]	[]	[]	[]	[]	[]	[]	[]	[]	[]	[]	[]	
Rated Input/Output	Rated Input Current	ND	10	13	19	25	31	36	47	59	70	87	113	142
		A	HD	8.7	10	13	19	25	31	36	47	59	70	87
	Rated Input Capacity	ND	9	12	17	22	28	33	43	54	64	80	103	130
		kVA	HD	8	9	12	17	22	28	33	43	54	64	80
Rated Output Current*1	ND	11	14	21	27	34	40	52	65	77	96	124	156	
	A	HD	9.6	11	14	21	27	34	40	52	65	77	96	124

Model	CIMR-UA: []	[]	[]	[]	[]	[]	[]	[]	[]	[]	[]	[]	[]
Rated Input/Output	Rated Input Current	ND	164	197	218	275	329	377	434	537	655	819	846
		A	HD	142	164	197	218	275	329	377	434	537	655
	Rated Input Capacity	ND	150	180	200	251	300	344	396	490	598	748	773
		kVA	HD	130	150	180	200	251	300	344	396	490	598
Rated Output Current*1	ND	180	216	240	302	361	414	477	590	720	900	930	
	A	HD	156	180	216	240	302	361	414	477	590	720	900

Common Specifications

Rated Input/Output	Max. Output Voltage	Depends on input voltage
	Max. Output Frequency	400 Hz
Power Supply Characteristics	Rated Voltage/Rated Frequency	200 V Class: Three-phase AC power supply 200 to 240 Vac 50/60 Hz 400 V Class: Three-phase AC power supply (CIMR-U []4A []/4P []): 380 to 500 Vac*3 50/60 Hz Three-phase AC power supply (CIMR-U []4E []/4W []): 380 to 480 Vac 50/60 Hz
	Allowable Voltage Fluctuation	-15% to +10%
	Allowable Frequency Fluctuation	±3% (Frequency fluctuation rate: 1 Hz/100 ms or less)
	Allowable Power Voltage Imbalance between Phases	2% or less
Control Characteristics	Control Method	Sine-wave PWM (V/f control, V/f Control with PG, Open Loop vector control, Closed Loop Vector Control, Open Loop Vector Control for PM, Advanced Open Loop Vector Control for PM, Closed Loop Vector Control for PM (switched by parameter setting))
	Harmonic Current Distortion Rate*2	5% or less (IEEE 519)
	Input Power Factor	0.98 or more (for rated operation)
Status Output	Overload Tolerance	HD Rating: 150% of rated output current for 60 s, ND Rating: 120% of rated output current for 60 s (Derating may be required for repetitive loads)
		1 C-relay output at failures, 1 a contact output (multi-function) during operation, 2 multi-function PHC outputs selectable at alarms, 2 multi-function analog outputs selectable for analog outputs, Pulse train output: 1 (multi-function)

*1 : The rated output current of the drive should be equal to or greater than the motor rated current.

*2 : When the harmonic current distortion rate is 5% or less, the maximum output voltage is calculated by multiplying input power voltage × 0.87. You must also change the parameter from the default setting.

*3 : Use a three-phase power supply of 380 to 480 Vac for models CIMR-U []4 []0477 to 4 []0930 with an EMC filter connected.

■ U1000 Dimensions mm

200 V Class Open Chassis (IP00)

Model	CIMR-UA: []	[]	[]	[]	[]	[]	[]	[]	[]	[]
Width (W)	250	264	264	264	264	264	264	415	415	490
Height (H)	480	650	650	650	650	816	816	990	990	1132
Depth (D)	360	420	420	420	420	450	450	403	403	450

400 V Class Open Chassis (IP00)

Model	CIMR-UA: []	[]	[]	[]	[]	[]	[]	[]	[]	[]	[]	[]	[]	[]	[]	[]	[]	[]	[]				
Width (W)	250	250	250	250	250	264	264	264	264	264	415	415	490	490	695	695	695	695	1070	1070	1210	1210	1210
Height (H)	480	480	480	480	480	650	650	650	650	816	816	990	990	1132	1132	1132	1132	1132	1595	1595	1835	1835	1835
Depth (D)	360	360	360	360	360	420	420	420	420	450	450	403	403	450	450	450	450	450	445	445	445	445	445

Note: 1 Optional UL Type 1 kit is required for Enclosed Wall-Mounted (UL Type 1) models.

2 Refer to U1000 catalog (No. KAEP71063602) for details.

Model	EUJ7118 []	00	10	20
U1000 Standard Configuration Devices (Harmonic Filter Module)	Width (W)	700	700	700
	Height (H)	1350	1350	1350
	Depth (D)	432	432	432



YASKAWA ELECTRIC CORPORATION

Tokyo Office Phone (03)5402-4905
New Pier Takeshiba South Tower, 16-1 Kaigan
1 Chome, Minato-ku, Tokyo 105-6891 Japan

Chubu Office Phone (0561) 36-9322
2-3-1 Neura-machi, Miyoshi, Aichi 470-0217 Japan

Osaka Office Phone (06)6346-4520
Shin-Fujita Building, 4-27 Doujima 2 Chome,
Kita-ku, Osaka 530-0003 Japan

Kyushu Office Phone (092)714-5906
Tenjin Twin Building, 6-8 Tenjin 1 Chome,
Chuo-ku, Fukuoka 810-0001 Japan

Official website <http://www.yaskawa.co.jp/>
Products and technical information website
<http://www.e-mechatronics.com/>

Contact for Technical Inquiries (Inverter Call Center)
Phone: 0120-114-616 FAX: 0120-114-537
Monday through Friday
(excluding public and company holidays)
9:00 to 12:00, 13:00 to 16:30

Note: Faxes are accepted 24 hours a day.

Contact Information

Specifications are subject to change without notice for ongoing product modifications and improvements. For inquiries on the contents of this document, contact a Yaskawa representative or the Yaskawa sales department listed above.