

# AC Servo Drives $\Sigma$ -V Series Product Catalog



# YASKAWA

Certified for  
ISO9001 and  
ISO14001



JQA-0422



JQA-EM0202

JQA-EM0924

# Build the machine you've dreamed of, today!

AC servo drive  
Sigma Five



You want maximum effect quickly and easily, as does every engineer in the field. And now the  $\Sigma$ -V series is here with the practical answer to your dreams!

How many times have you heard people say servos need adjustment to work well? Our new tuning-less function means it works as soon as you hook it up!

And if you want more performance than ever before, the  $\Sigma$ -V series advanced autotuning function lets you set up for it rapidly.

Advanced technology makes possible a host of safety standards compliance for the first time in Japan (as of April 2007), compliance with key international standards, a diverse motor line-up, compact size, high speed and simple maintenance: everything you need to answer today's requirements.

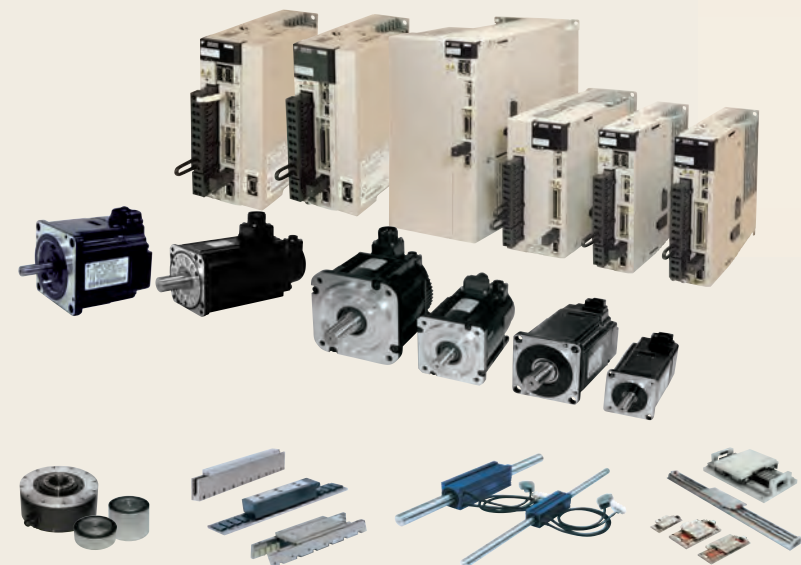

International Standards



Safety Standards

Safety Stop-0 (Standard)

RoHS Directive

RoHS Directive Stands for the EU directive on the Restriction of the Use of Certain Hazardous Substances in Electrical and Electronic Equipment.



Features

Superlative Performance

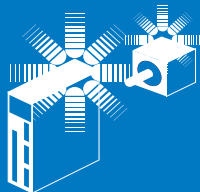

Operate your machinery faster and with higher precision than ever!

The  $\Sigma$ -V delivers the highest performance in the industry.

The best amplifier response in the industry slashes settling time

In-house comparison: 1/12th

Outstanding frequency response

1.6 kHz\*



\* Representative value when using a combination of the SGMJV-02ADA servomotor and SGDV-1R6A SERVOPACK at one time of the load moment of inertia ratio.

● Servo Adjustment Example: When the ball screw slider was run using a combination of the SGMJV-02ADA servomotor and SGDV-1R6A SERVOPACK.

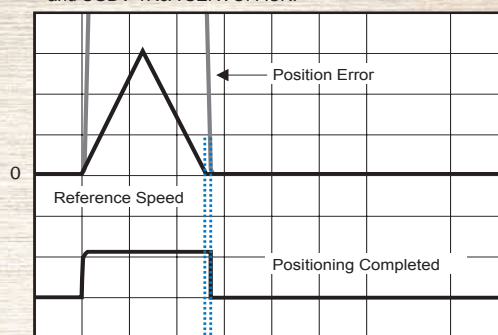

➔ Settling Time 0 to 4 ms !

Enhanced vibration suppression

Existing functions to minimize vibration have been enhanced, and new ones added, improving tracking and further improving settling time. Vibration and noise during driving have also been cut, along with vibration at machine edges when stopping.

Contributing to machine performance in conjunction with a medium-inertia motor

Small Capacity  
SGMJV Series



Low Heating

Improved motor constants have reduced both losses and heating.

Better Cycle Time

Instantaneous peak torque has been boosted from 300% to 350%, contributing to shorter cycle times

Ease of Use

Moment of inertia ratio has been doubled in the same motor, reducing the moment of inertia ratio and boosting gain for faster settling

Medium Capacity  
SGMGV Series

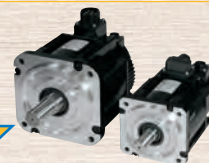

Compact Design

Smaller package and about 20% lighter, but with the same moment of inertia ratio as the conventional model. A small encoder connector is applied.

Improved Vibration Resistance

New coupling delivers typical 5G vibration resistance

Encoder resolution  
1,048,576 pulses/revolution



# Simple Start-up

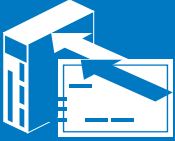

Making servo adjustment quick and simple

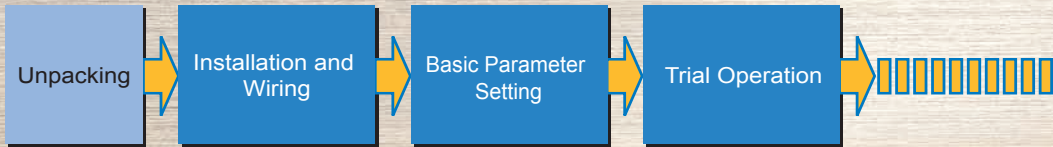

## Faster setup

SigmaWin+

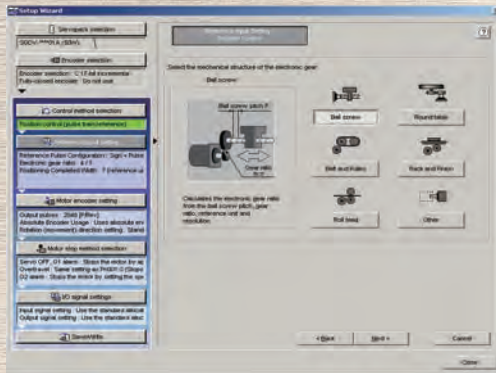

Setup Wizard  
Simple parameter set-up with wizard-aided input

Wiring Check Function  
The SigmaWin+ wiring check function checks your wiring in a single operation

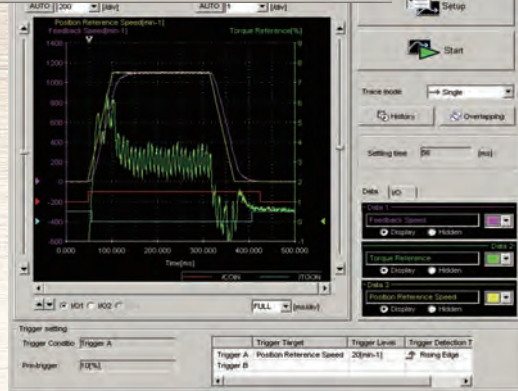

USB1.1 Support

Trace Function  
Realtime trace of adjustment state means you can check instantly.

● Full of handy functions for start-up and more effective operation!

### ■ Selection

Servomotor capacity selection software

SigmaJunmaSize+

Optimal selection for your application:  
With consideration of moment of inertia, DB resistance, etc.





# Let the $\Sigma$ -V series simplify your life!

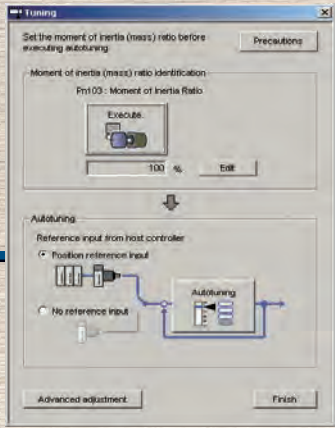
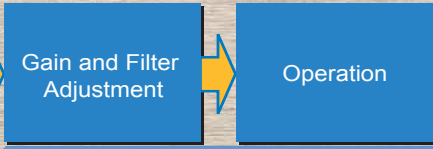

New Advanced Autotuning Window

## Simple Tuning

Get up and running quickly after hooking up the motor  
 ● New Tuning-less Function

Even without servo adjustment and with load changes, oscillation- and vibration-free drive is possible up to 20 times the load moment of inertia.  
 Settling time: 100 to 150 ms level

Minimize settling time with less vibration  
 ● New Advanced Autotuning

The reference filter and feedback gain adjustment functions have a new automatic feed forward gain adjustment for optimal adjustment performance. The friction compensation function automatically cancels out the effect of friction on machine characteristics.  
 Settling time: 10 ms level

Fine-tuning is a must  
 ● New "One-parameter" Tuning

Fine-tuning can tweak machine performance to the max.  
 Settling time: 0 to 4 ms level

### Maintenance Faster Troubleshooting

Engineering tool  
 SigmaWin+

Alarm diagnostic function:  
 Presumes possible causes of the alarm and immediately displays suggested corrective actions.

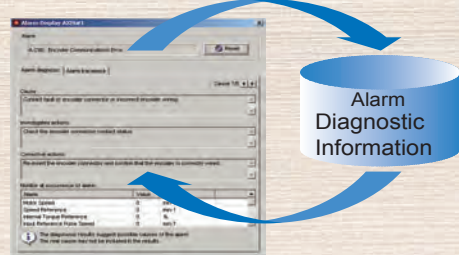



# Outstanding Expandability

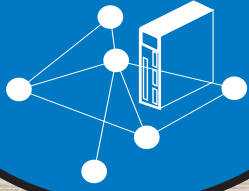

Use servos that really fit into your system



A rich selection of models and options to match your requirements

- Extensive variety of motors to match any machine
  - Medium-inertia servomotors → Improved control stability
  - Low-inertia servomotors → High-speed acceleration and deceleration
- Selection of servo actuators
  - Support for direct drive servomotors, linear servomotors and linear sliders
- Standard support for analog voltage/pulse train reference series or MECHATROLINK-II communications reference series
- Wide selection of option modules for various communication interfaces and feedback
- Compliant with applicable safety standards
  - Easy compliance with machine safety standards
- Motor line-up to handle a wide range of markets and applications

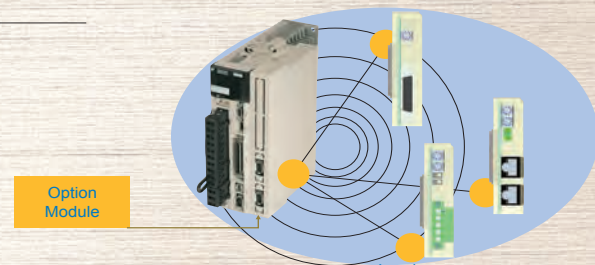

**The first in the industry in Japan!**  
(as of April 2007)

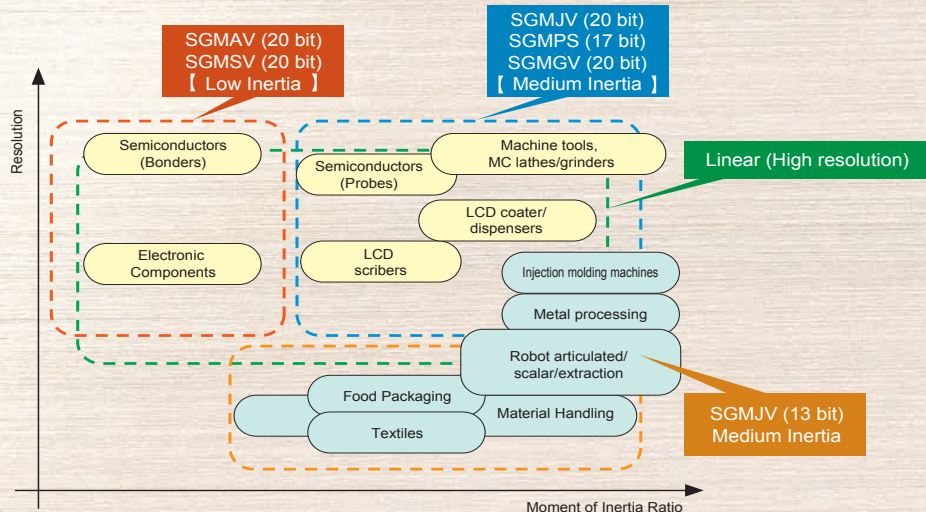



# Product Line-up

## Servomotors

### ◆Rotary Servomotors (Small Capacity)



SGMMV: 3.3 W to 30 W  
(Low Inertia, Small Capacity)



SGMJV: 50 W to 750 W  
(Medium Inertia, Small Capacity)



SGMAV: 50 W to 1 kW  
(Low Inertia, Small Capacity)

### ◆Rotary Servomotors (Medium Capacity)



SGMGV: 300 W to 15 kW  
(Medium Inertia, Medium Capacity)



SGMSV: 1.0 kW to 7.0 kW  
(Low Inertia, Medium Capacity)

### ◆Direct Drive Servomotors



SGMCS: 2 to 3.5 Nm  
(Small Capacity)



SGMCS: 45 to 200 Nm  
(Medium Capacity)

### ◆Linear Servomotors

#### Linear $\Sigma$ Series



SGLGW (Coreless Type)  
12.5 to 750 N

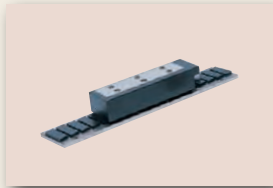

SGLFW (With F-type Iron Core)  
25 to 1120 N



SGLTW (With T-type Iron Core)  
130 to 1300 N

### ◆Linear Slides $\Sigma$ -Trac Series

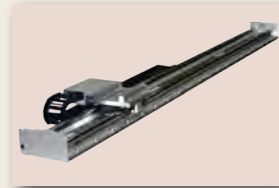

SGT1F ( $\Sigma$ -Trac)  
47 to 560 N

## SERVOPACKs with AC Power Input

### ◆ Analog Voltage/Pulse Train Reference



SGDV-00000105

### ◆ MECHATROLINK-II Reference



SGDV-00001115

### ◆ MECHATROLINK-III Reference



SGDV-00002125

### ◆ Command Option Attachable Type



SGDV with Additional Options

Available Option Modules include:

- EtherCAT (CoE) Communication
- Fully Closed Loop Control
- MP2600iec Single Axis Controller
- Functional Safety
- Indexer

## SERVOPACKs with DC Power Input

### ◆ Analog Voltage Reference



SGDV-0000ES1

### ◆ Pulse Train Reference



SGDV-0000EP1

### ◆ MECHATROLINK-II Reference



SGDV-0000E11

### ◆ MECHATROLINK-III Reference



SGDV-0000E21

## ◆ Stock Status Definitions

The product selection tables in this catalog contain stock status codes, which are subject to change. The codes are defined below:

### **S** Stock Item

Normally 3 to 5 days leadtime for most order quantities. 3 to 5 weeks maximum if temporary outages occur. For critical lead time or large quantity shipments, check with your Yaskawa sales representative.

### **LS** Limited Stock Item

Typically small quantities are available from stock. Items may become stock items as demand increases.

### **NS** Non-Stock Item

Non-stock items typically carry a 12 - 16 week delivery time.

### **GS** Global Support Item

Global Support Products are non-stock items that are not promoted in North America. Delivery is typically 14-20 weeks depending on price availability. Local repair and service capabilities may be limited. Customers should consider stock or limited stock substitutes if possible. Global Support Products are found on some machines imported to North America. In many cases the fastest delivery of spare parts can be obtained by contacting the original machine builder. Yaskawa Electric America can make special arrangements for servicing customers on a contract basis.

◆Rotary Servomotors and SERVOPACKs with AC Power Input

Rotary Servomotor Model		Capacity	SERVOPACK Model SGD□□□□			Stock Status			
			Single-phase 100 VAC	Three-phase 200 VAC	Three-phase 400 VAC				
SGMMV (Ultra-Small Capacity) 3000RPM	SGMMV-A1A	10 W	R90F	R90A	—	S			
	SGMMV-A2A	20 W		R90A					
	SGMMV-A3A	30 W		1R6A					
SGMJV (Medium Inertia, Small Capacity) 3000RPM	SGMJV-A5A	50 W	R70F	R70A	—	S			
	SGMJV-01A	100 W	R90F	R90A					
	SGMJV-C2A	150 W	2R1F	1R6A					
	SGMJV-02A	200 W	2R1F	1R6A					
	SGMJV-04A	400 W	2R8F	2R8A					
	SGMJV-06A	600 W	—	5R5A					
	SGMJV-08A	750 W	—	5R5A					
SGMAV (Low Inertia, Small Capacity) 3000RPM	SGMAV-A5A	50 W	R70F	R70A	—	S			
	SGMAV-01A	100 W	R90F	R90A					
	SGMAV-C2A	150 W	2R1F	1R6A					
	SGMAV-02A	200 W	2R1F	1R6A					
	SGMAV-04A	400 W	2R8F	2R8A					
	SGMAV-06A	550 W	—	5R5A					
	SGMAV-08A	750 W	—	5R5A					
SGMGV (Medium Inertia, Medium Capacity) 1500RPM	SGMGV-03A	300 W	—	3R8A	—	S			
	SGMGV-05A	450 W		7R6A					
	SGMGV-09A	850 W		120A					
	SGMGV-13A	1.3 kW		180A					
	SGMGV-20A	1.8 kW		330A/200A <sup>*2</sup>					
	SGMGV-30A	2.9 kW		330A					
	SGMGV-44A	4.4 kW		470A					
	SGMGV-55A	5.5 kW		550A					
	SGMGV-75A	7.5 kW		590A					
	SGMGV-1AA	11 kW		780A					
	SGMGV-1EA	15 kW		780A					
	SGMGV-03D	300 W		—			1R9D	—	S
	SGMGV-05D	450 W					3R5D		
	SGMGV-09D	850 W					5R4D		
	SGMGV-13D	1.3 kW					8R4D		
	SGMGV-20D	1.8 kW					120D		
	SGMGV-30D	2.9 kW					170D		
	SGMGV-44D	4.4 kW					210D		
	SGMGV-55D	5.5 kW					260D		
SGMGV-75D	7.5 kW	280D							
SGMGV-1AD	11 kW	370D							
SGMGV-1ED	15 kW	370D							
SGMSV (Low Inertia, Medium Capacity) 3000RPM	SGMSV-10A	1.0 kW	—		7R6A	—	S		
	SGMSV-15A	1.5 kW			120A				
	SGMSV-20A	2.0 kW		180A					
	SGMSV-25A	2.5 kW		200A					
	SGMSV-30A	3.0 kW		200A					
	SGMSV-40A	4.0 kW		330A					
	SGMSV-50A	5.0 kW		330A					
	SGMSV-70A	7.0 kW		550A					
	SGMSV-10D	1.0 kW		—	3R5D			—	S
	SGMSV-15D	1.5 kW			5R4D				
	SGMSV-20D	2.0 kW			8R4D				
	SGMSV-25D	2.5 kW			120D				
	SGMSV-30D	3.0 kW			120D				
	SGMSV-40D	4.0 kW			170D				
	SGMSV-50D	5.0 kW			170D				

\*1: Single-phase 200 VAC SERVOPACKs are also available (SERVOPACK model: SGD□V-120A□□□A008000).

\*2: The combination of the SGD□V-200A SERVOPACK and the SGM□V-30A servomotor must be used at the following reduction ratings.

		Reduction Ratings	Ratings
Rated Current	$A_{rms}$	19.6	23.8
Rated Torque	Nm	15.3	18.6
Allowable Load Moment of Inertia		3 times	5 times

◆Rotary Servomotors and SERVOPACKs with DC Power Input

Rotary Servomotor Model		Capacity	SERVOPACK Model SGD□-□□□□		Stock Status
			24 VDC/48 VDC		
SGMMV (Low Inertia, Ultra-small Capacity) 3000 min <sup>-1</sup>	SGMMV-B3E	3.3 W	1R7E	S	
	SGMMV-B5E	5.5 W			
	SGMMV-B9E	11 W			
	SGMMV-A1E	10 W	2R9E		
	SGMMV-A2E	20 W			
SGMMV-A3E	30 W				

◆Linear Servomotors and SERVOPACKs with AC Power Input

Linear Servomotor Model		Rated Force N	Peak Force N	SERVOPACK Model SGD□-□□□□			Stock Status				
				Single-phase 100 VAC	Three-phase 200 VAC	Three-phase 400 VAC					
SGLGW (Coreless Type, With standard magnetic way)	SGLGW-30A050C	12.5	40	R70F	R70A	—	S				
	SGLGW-30A080C	25	80	R90F	R90A						
	SGLGW-40A140C	47	140								
	SGLGW-40A253C	93	280	2R1F	1R6A						
	SGLGW-60A140C	70	220	2R8F	2R8A						
	SGLGW-40A365C	140	420								
	SGLGW-60A253C	140	440	—	5R5A						
	SGLGW-60A365C	210	660		120A						
	SGLGW-90A200C	325	1300		180A						
	SGLGW-90A370C	550	2200		200A						
SGLGW-90A535C	750	3000									
SGLGW (Coreless Type, With high-efficiency magnetic way)	SGLGW-40A140C	57	230	2R1F	1R6A	—	NS				
	SGLGW-60A140C	85	360	2R8F	2R8A						
	SGLGW-40A253C	114	460		—			3R8A			
	SGLGW-40A365C	171	690	7R6A							
	SGLGW-60A253C	170	720								
SGLGW-60A365C	255	1080									
SGLFW (With F-type Iron Core)	SGLFW-20A090A	25	86	2R1F	1R6A	—	S				
	SGLFW-20A120A	40	125								
	SGLFW-35A120A	80	220								
	SGLFW-35A230A	160	440	—	3R8A						
	SGLFW-50A200B	280	600		5R5A						
	SGLFW-50A380B	560	1200		120A						
	SGLFW-1ZA200B	560	1200		200A						
	SGLFW-1ZA380B	1120	2400	—	—			1R9D			
	SGLFW-35D120A	80	220					3R5D			
	SGLFW-35D230A	160	440					5R4D			
	SGLFW-50D200B	280	600					120D			
	SGLFW-50D380B	560	1200								
	SGLFW-1ZD200B	560	1200								
	SGLFW-1ZD380B	1120	2400								
SGLTW (With T-type Iron Core)	SGLTW-20A170A	130	380	—	3R8A	—	NS				
	SGLTW-35A170A	220	660		5R5A						
	SGLTW-35A170H	300	600		7R6A			120A			
	SGLTW-50A170H	450	900								
	SGLTW-20A320A	250	760		—				180A		
	SGLTW-20A460A	380	1140								
	SGLTW-35A320A	440	1320							330A	
	SGLTW-35A320H	600	1200								
	SGLTW-50A320H	900	1800								
	SGLTW-35A460A	670	2000								
	SGLTW-40A400B	670	2600							—	3R5D
	SGLTW-40A600B	1000	4000								
	SGLTW-80A400B	1300	5000		8R4D						
	SGLTW-35D170H	300	600								
	SGLTW-50D170H	450	900					120D			
	SGLTW-35D320H	600	1200					170D			
	SGLTW-50D320H	900	1800								
	SGLTW-40D400B	670	2600								
	SGLTW-40D600B	1000	4000								
	SGLTW-80D400B	1300	5000								



### ◆Linear Slides ( $\Sigma$ -Trac) and SERVOPACKs

Linear Slide Model		Rated Force N	Peak Force N	SERVOPACK Model SGD□-□□□□		Stock Status
				Single-phase 100 VAC	Three-phase 200 VAC	
SGT1F ( $\Sigma$ -Trac)	SGT1F31-	80	220	2R1F	1R6A	LS
	SGT1F41-	160	440		3R8A	
	SGT1F91-	280	600	—	5R5A	
	SGT1FA1-	560	1200		120A	
SGTMM ( $\Sigma$ -Trac- $\mu$ )	SGTMM-01	3.5	10	R70F	R70A	GS
	SGTMM-03	7	25	R90F	R90A	
SGTMF ( $\Sigma$ -Trac-MAG)	SGTMF-4A	90	270	2R1F	1R6A	GS
	SGTMF-4B	120	360			
	SGTMF-5A	180	540	—	5R5A	
	SGTMF-5B	240	720			

### ◆Direct Drive Servomotors and SERVOPACKs

Direct Drive Servomotor Model		Rated Torque N m	Peak Torque N m	SERVOPACK Model SGD□-□□□□		Stock Status
				Single-phase 100 VAC	Three-phase 200 VAC	
SGMCS (Small Capacity)	SGMCS-02B	2	6	2R1F	2R8A	S
	SGMCS-05B	5	15			
	SGMCS-07B	7	21			
	SGMCS-04C	4	12	2R8F		
	SGMCS-10C	10	30			
	SGMCS-14C	14	42			
	SGMCS-08D	8	24			
	SGMCS-17D	17	51			
	SGMCS-25D	25	75			
	SGMCS-16E	16	48	—		
SGMCS-35E	35	105	—	5R5A		
SGMCS (Medium Capacity)	SGMCS-45M	45	135	—	7R6A	S
	SGMCS-80M	80	240		120A	
	SGMCS-80N	80	240		180A	
	SGMCS-1AM	110	330		200A	
	SGMCS-1EN	150	450			
	SGMCS-2ZN	200	600			

# Contents



<b>Servomotors</b>	<b>Rotary Servomotors</b>	<b>1</b>	▶	
	Ultra-Small Capacity	SGMMV	1	
	Medium Inertia, Small Capacity	SGMJV	21	
	Low Inertia, Small Capacity	SGMAV	35	
	Medium Inertia, Medium Capacity	SGMGV	51	
	Low Inertia, Medium Capacity	SGMSV	75	
	Rotary Servomotor General Instructions		95	
	<b>Direct Drive Servomotors</b>		<b>105</b>	▶
	Small / Medium Capacity	SGMCS	105	
	<b>Linear Servomotors</b>		<b>123</b>	▶
	G-Type Coreless	SGLGW	123	
	F-Type Iron Core	SGLFW	143	
	T-Type Balanced Iron Core	SGLTW	163	
	Linear Servomotor General Instructions		191	
<b>Linear Slides</b>		<b>199</b>	▶	
$\Sigma$ -Trac	SGT1F	199		
<b>SERVOPACKs AC Power Input</b>	<b>Analog Voltage/Pulse Train Reference Type SERVOPACKs</b>	<b>207</b>	▶	
	<b>MECHATROLINK-II Communications Reference Type SERVOPACKs</b>	<b>231</b>	▶	
	<b>MECHATROLINK-III Communications Reference Type SERVOPACKs</b>	<b>253</b>	▶	
	<b>SERVOPACK with Additional Options</b>	<b>267</b>	▶	
	<b>Wiring Main Circuit and Peripheral Devices</b>	<b>323</b>	▶	
<b>SERVOPACKs DC Power Input</b>	<b>Analog Voltage/Pulse Train Reference Type</b>	<b>341</b>	▶	
	<b>MECHATROLINK-II Communications Reference Type</b>	<b>351</b>	▶	
	<b>MECHATROLINK-III Communications Reference Type</b>	<b>361</b>	▶	
	<b>DC SERVOPACK Dimensions</b>	<b>371</b>	▶	
	<b>Wiring Main Circuit and Peripheral Devices</b>	<b>373</b>	▶	
<b>Others</b>	<b>Selecting Servomotor Capacity and Regenerative Capacity</b>	<b>381</b>	▶	
	<b>Connection to Host Controller</b>	<b>397</b>	▶	

# Rotary Servomotors

# SGMMV



## Model Designations

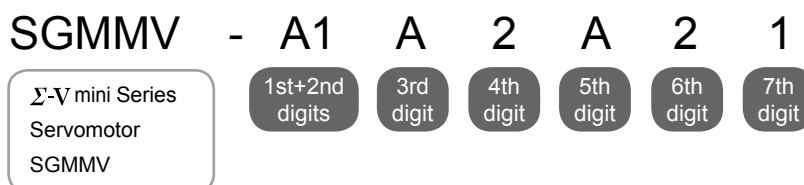

### 1st+2nd digits Rated Output

Code	Specifications
B3	3.3 W
B5	5.5 W
B9	11 W
A1	10 W
A2	20 W
A3	30 W

### 5th digit Design Revision Order

Code	Specifications
A	Standard

### 6th digit Shaft End

Code	Specifications
2	Straight (Standard)
A	Straight with flat seats (Optional)

### 7th digit Options

Code	Specifications
1	Without options
C	With holding brake (24 VDC, flange size: 25 mm×25 mm)

### 3rd digit Power Supply Voltage

Code	Specifications
A	200 VAC (Flange size: 25 mm×25 mm)
E	24 VDC/48 VDC*

\*: Same for 24 VDC and 48 VDC. Characteristics vary with the voltage of the main circuit for SERVOPACKs

### 4th digit Serial Encoder

Code	Specifications
2	17-bit absolute

## Features

- Ultra-compact, ultra-small capacity  
With flange size of 15 mm×15 mm: 3.3 W to 11 W  
With flange size of 25 mm×25 mm: 10 W to 30 W
- Mounted 17-bit high-resolution absolute serial encoder:  
Can be used as an incremental encoder
- Maximum speed: 6,000 RPM
- Wide selection: Two flange sizes, AC or DC power\*, and holding brakes\*

\*: Only the 25 mm×25 mm flange can be used with a 200-VAC power supply or a holding brake.

## Application Examples

### Equipment

- Semiconductor equipment
- LCD manufacturing equipment
- Electronic parts assembly and electronic parts manufacturing equipment
- Metal processing machines
- Robots
- Assemblers
- Inspection and measurement devices
- Clean systems
- Automated guided vehicles (AGVs)
- Equipment for biomedical

### Machinery

- Bonders, probers, IC handlers, chip sorters, and OHT
- Dispensers, scribe, electrode-mounting device, and inspection device
- Mounters, inserters, and solder printers
  
- Coil winders and spring machinery
- X-Y robots, assembler robots
- Screw tighters

### ● Precautions when using AC or DC power input

Applicable servomotors, SERVOPACKs, and cables differ depending on if AC or DC power is used. Refer to the relevant pages and be sure to select the correct models.

#### With DC power

Applicable servomotors: SGMMV-□□E  
Applicable SERVOPACKs: SGD□V-□□□E

- Refer to page x for information on combining servomotors and SERVOPACKs.
- Refer to pages 10 to 14 for information on selecting servomotor cables.

#### With AC power

Applicable servomotors: SGMMV-□□A  
Applicable SERVOPACKs: SGD□V-□□□F and SGD□V-□□□A

- Refer to page ix for information on combining servomotors and SERVOPACKs.
- Refer to pages 15 to 19 for information on selecting servomotor cables.



# Ratings and Specifications

Time Rating: Continuous  
 Vibration Class: V15  
 Insulation Resistance: 500 VDC, 10 MΩ min.  
 Ambient Temperature: 0 to 40°C  
 Excitation: Permanent magnet  
 Mounting: Flange-mounted  
 Thermal Class: 15 mm×15 mm B (UL: A)  
 25 mm×25 mm B  
 Withstand Voltage: 600 VAC for one minute

Enclosure: 15 mm×15 mm: Totally enclosed, self-cooled, IP42  
 (except for shaft opening)  
 25 mm×25 mm: Totally enclosed, self-cooled,  
 IP55 (except for shaft opening)  
 Ambient Humidity: 20% to 80% (no condensation)  
 Drive Method: Direct drive  
 Rotation Direction: Counterclockwise (CCW) with forward run  
 reference when viewed from the load side

Voltage		24 VDC/48 VDC <sup>3</sup>					
Servomotor Model: SGMV-□□□□		B3E	B5E	B9E	A1E	A2E	A3E
Rated Output <sup>1</sup>	W	3.3	5.5	11	10	20	30
Rated Torque <sup>1, 2</sup>	Nm	0.0105	0.0175	0.0350	0.0318	0.0637	0.0955
Instantaneous Peak Torque <sup>1</sup>	Nm	0.0263	0.0438	0.0875	0.0955	0.191	0.286
Rated Current <sup>1</sup>	A <sub>rms</sub>	1.5	1.5	1.7	2.1	2.0	2.9
Instantaneous Max. Current <sup>1</sup>	A <sub>rms</sub>	3.6	3.7	4.1	6.1	5.8	8.6
Rated Speed <sup>1</sup>	RPM	3000					
Max. Speed <sup>1</sup>	RPM	6000					
Torque Constant	Nm/A <sub>rms</sub>	0.00814	0.0132	0.0241	0.0172	0.0358	0.0358
Rotor Moment of Inertia	kg·m <sup>2</sup>	4.41×10 <sup>-8</sup>	7.96×10 <sup>-8</sup>	2.21×10 <sup>-7</sup>	2.72×10 <sup>-7</sup> (4.07×10 <sup>-7</sup> )	4.66×10 <sup>-7</sup> (6.02×10 <sup>-7</sup> )	6.68×10 <sup>-7</sup> (8.04×10 <sup>-7</sup> )
Rated Power Rate <sup>1</sup>	kW/s	2.50	3.85	5.54	3.72	8.71	13.7
Rated Angular Acceleration <sup>1</sup>	rad/s <sup>2</sup>	238000	220000	158000	117000	137000	143000
Flange Size	mm	15×15			25×25		
Applicable SERVOPACK	SGDV-□□□□	1R7E			2R9E		

\*1: These items and torque-motor speed characteristics quoted in combination with an SGDV SERVOPACK are at an armature winding temperature of 100°C. Other values quoted are at 20°C.

\*2: Rated torques are continuous allowable torque values at 40°C with an aluminum heat sink of the following dimensions attached.

SGMMV-B3E, -B5E, -B9E, -A1E, -A2E: 150 mm×150 mm×3 mm

SGMMV-A3E : 250 mm×250 mm×6 mm

\*3: Torque-speed characteristics differ depending on if a 24 VDC or a 48 VDC is used for the main circuit for the SERVOPACK.

Note: The values in parentheses are for servomotors with holding brakes.

## ● Torque-Motor Speed Characteristics A : Continuous Duty Zone B : Intermittent Duty Zone

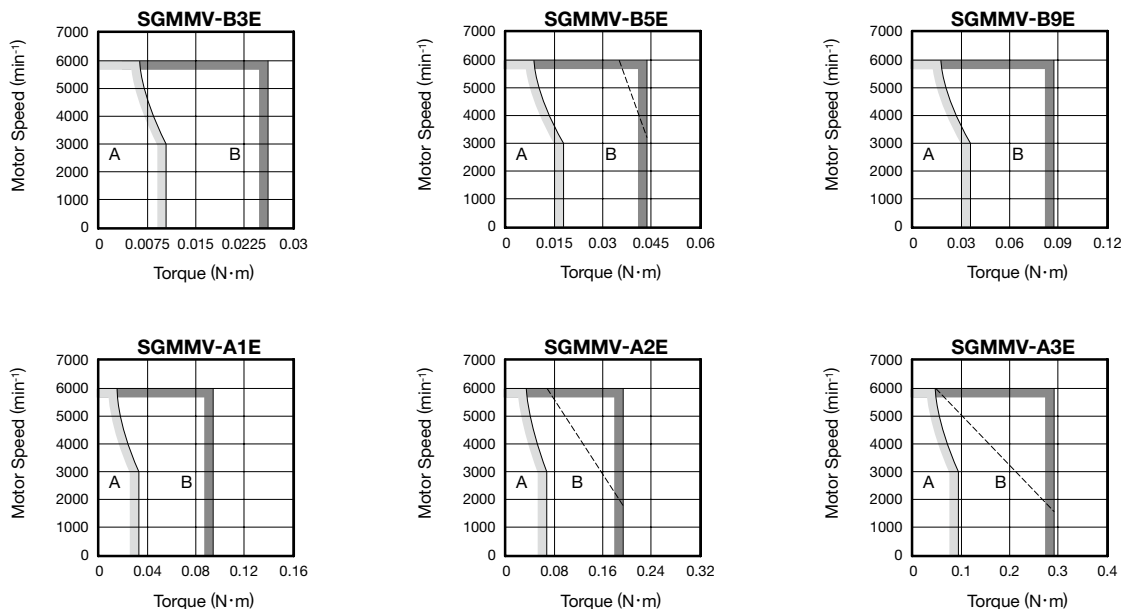

Notes: 1 The characteristics of the intermittent duty zone differ depending on the supply voltage.

Solid lines indicate characteristics when a 48-VDC power supply is applied to the main circuit of the SERVOPACK, and dotted lines indicate characteristics when a 24 VDC is applied.

For SGMMV-B3E, -B9E, -A1E SERVOPACKs, characteristics are the same for both 24-VDC or 48-VDC versions.

2 When the effective torque is within the rated torque, the servomotor can be used within the intermittent duty zone.

## Ratings and Specifications

Time Rating: Continuous  
 Vibration Class: V15  
 Insulation Resistance: 500 VDC, 10 M $\Omega$  min.  
 Ambient Temperature: 0 to 40°C  
 Excitation: Permanent magnet  
 Mounting: Flange-mounted  
 Thermal Class: B

Withstand Voltage: 1500 VAC for one minute  
 Enclosure: Totally enclosed, self-cooled, IP55  
 (except for shaft opening)  
 Ambient Humidity: 20% to 80% (no condensation)  
 Drive Method: Direct drive  
 Rotation Direction: Counterclockwise (CCW) with forward run  
 reference when viewed from the load side

Voltage		200 VAC		
Servomotor Model: SGMMV-□□□		A1A	A2A	A3A
Rated Output <sup>1</sup>	W	10	20	30
Rated Torque <sup>1, 2</sup>	Nm	0.0318	0.0637	0.0955
Instantaneous Peak Torque <sup>1</sup>	Nm	0.0955	0.191	0.286
Rated Current <sup>1</sup>	A <sub>rms</sub>	0.70	0.66	0.98
Instantaneous Max. Current <sup>1</sup>	A <sub>rms</sub>	2.0	1.9	2.9
Rated Speed <sup>1</sup>	RPM	3000		
Max. Speed <sup>1</sup>	RPM	6000		
Torque Constant	Nm/A <sub>rms</sub>	0.0516	0.107	0.107
Rotor Moment of Inertia	kg·m <sup>2</sup>	2.72×10 <sup>-7</sup> (4.07×10 <sup>-7</sup> )	4.66×10 <sup>-7</sup> (6.02×10 <sup>-7</sup> )	6.68×10 <sup>-7</sup> (8.04×10 <sup>-7</sup> )
Rated Power Rate <sup>1</sup>	kW/s	3.72	8.71	13.7
Rated Angular Acceleration <sup>1</sup>	rad/s <sup>2</sup>	117000	137000	143000
Flange Size	mm	25×25		
Applicable SERVOPACK	SGDV-□□□□	R90□		1R6A, 2R1F

\*1: These items and torque-motor speed characteristics quoted in combination with an SGD V SERVOPACK are at an armature winding temperature of 100°C. Other values quoted are at 20°C.

\*2: Rated torques are continuous allowable torque values at 40°C with an aluminum heat sink of the following dimensions attached.

SGMMV-A1A, -A2A: 150 mm×150 mm×3 mm

SGMMV-A3A : 250 mm×250 mm×6 mm

Note: The values in parentheses are for servomotors with holding brakes.

### ● Torque-Motor Speed Characteristics **A** : Continuous Duty Zone **B** : Intermittent Duty Zone

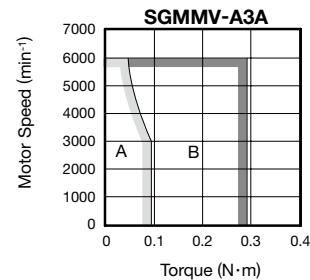
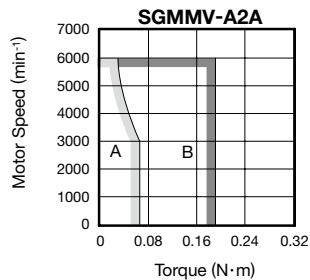
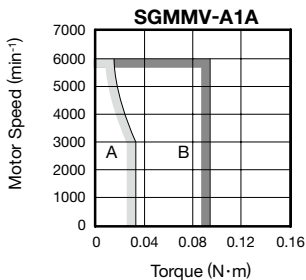

Notes: 1 The characteristics of the intermittent duty zone differ depending on the supply voltage.

2 When the effective torque is within the rated torque, the servomotor can be used within the intermittent duty zone.

# Ratings and Specifications

## ● Holding Brake Electrical Specifications

Holding Brake Rated Voltage	Servomotor Model	Servomotor Rated Output W	Holding Brake Specifications					
			Capacity W	Holding Torque Nm	Coil Resistance $\Omega$ (at 20°C)	Rated Current A(at 20°C)	Brake Release Time ms	Brake Operation Time ms
24 VDC $^{+10\%}_0$	SGMMV-A1E	10	2.0	0.0318	320	0.075	40	100
	SGMMV-A1A							
	SGMMV-A2E	20	2.6	0.0637	221.5	0.108	40	100
	SGMMV-A2A							
	SGMMV-A3E	30	2.6	0.0955	221.5	0.108	40	100
	SGMMV-A3A							

Notes: 1 The holding brake is only used to hold the load and cannot be used to stop the servomotor.  
 2 The holding brake open time and holding brake operation time vary depending on which discharge circuit is used. Make sure holding brake open time and holding brake operation time are correct for your servomotor.  
 3 A 24-VDC power supply is not included.

## ● Overload Characteristics

The overload detection level is set under hot start conditions at a servomotor ambient temperature of 40°C.

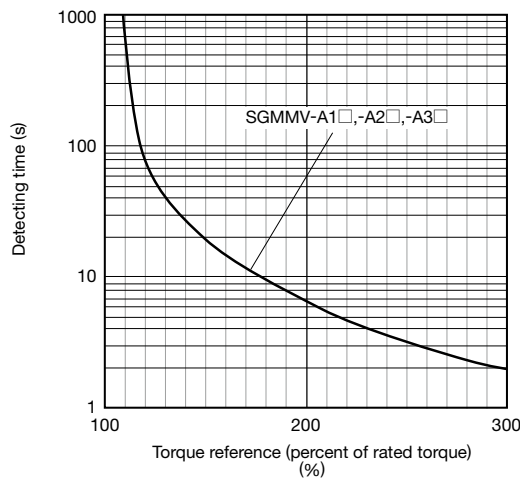
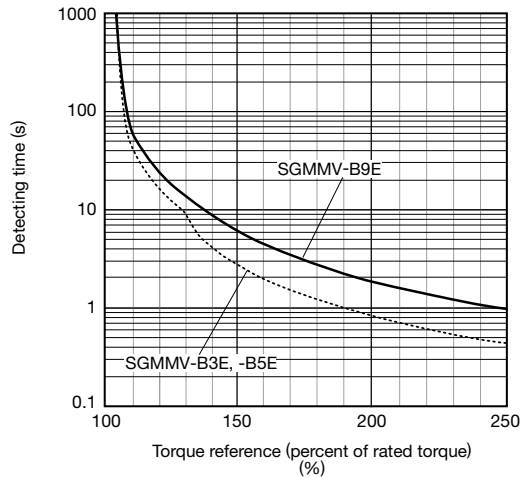

Note: Overload characteristics shown above do not guarantee continuous duty of 100% or more output. Use a servomotor with effective torque within the continuous duty zone of Torque-Motor Speed Characteristics.

## Ratings and Specifications

### ● Allowable Load Moment of Inertia at the Motor Shaft

The rotor moment of inertia ratio is the value for a servomotor without a gear and a holding brake.

Servomotor Model		Servomotor Rated Output	Allowable Load Moment of Inertia (Rotor Moment of Inertia Ratio)
SGMMV-	B3	3.3 W	30 times
	B5	5.5 W	
	B9	11 W	
	A1	10 W	
	A2	20 W	
	A3	30 W	

### ● Load Moment of Inertia

The larger the load moment of inertia, the worse the movement response.

The allowable load moment of inertia ( $J_L$ ) depends on the motor capacity, as shown above. This value is provided strictly as a guideline and results may vary depending on servomotor drive conditions.

Use the AC servo drive capacity selection program SigmaJunmaSize+ to check the operation conditions. The program can be downloaded for free from our web site (<http://www.e-mechatronics.com/>).

An overvoltage alarm (A.400) is likely to occur during deceleration if the load moment of inertia exceeds the allowable load moment of inertia. Take one of the following steps if this occurs.

- Reduce the torque limit.
- Reduce the deceleration rate.
- Reduce the maximum speed.

### ● Allowable Radial and Thrust Loads

Design the mechanical system so thrust and radial loads applied to the servomotor shaft end during operation fall within the ranges shown in the table.

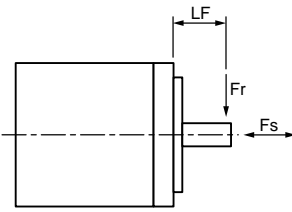
Servomotor Model		Allowable Radial Load ( $F_r$ ) N	Allowable Thrust Load ( $F_s$ ) N	LF mm	Reference Diagram
SGMMV-	B3	8	4	10	
	B5	8	4	10	
	B9	10	4	10	
	A1	34	14.5	16	
	A2	44	14.5	16	
	A3	44	14.5	16	



# External Dimensions Units: mm

## ● Without Holding Brakes

(1) 3.3 to 11 W

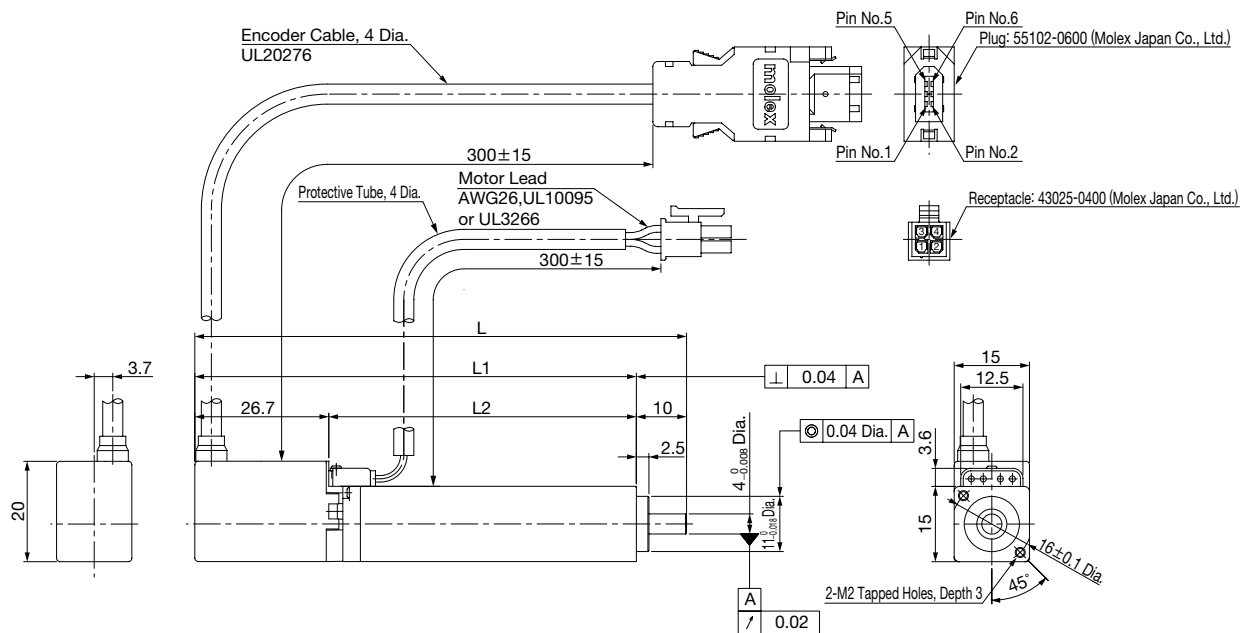

Model SGMMV-	L	L1	L2	Approx. Mass kg
B3E2A□1	58	48	21.3	0.055
B5E2A□1	64	54	27.3	0.06
B9E2A□1	98	88	61.3	0.1

## <Shaft End>

### ● With a Flat Seat

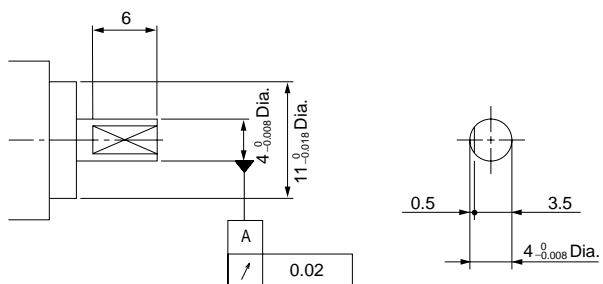

**External Dimensions** Units: mm

(2) 10 to 30 W

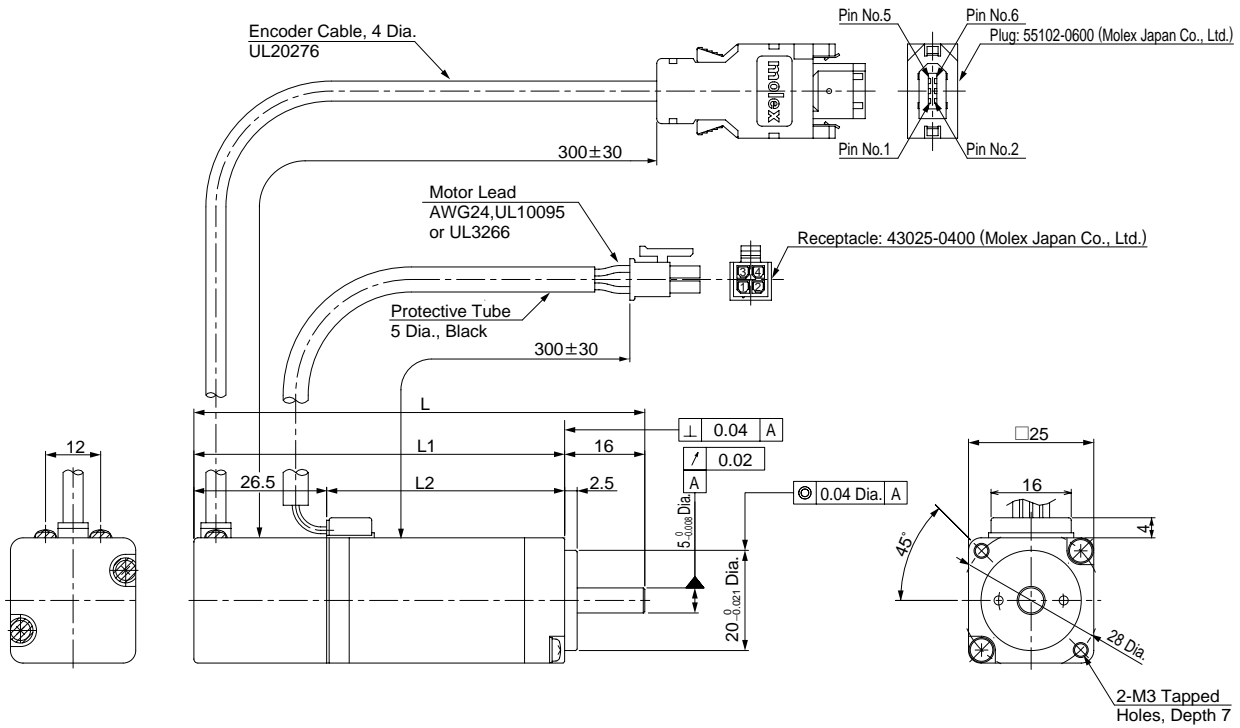

Model SGMMV-	L	L1	L2	Approx. Mass kg
A1□2A□1	70	54	27.5	0.13
A2□2A□1	80	64	37.5	0.17
A3□2A□1	90	74	47.5	0.21

<Shaft End>

●With a Flat Seat

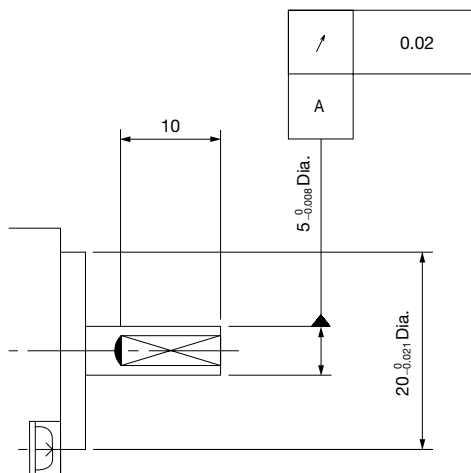

# External Dimensions Units: mm

## ● With Holding Brakes

(1) 10 to 30 W

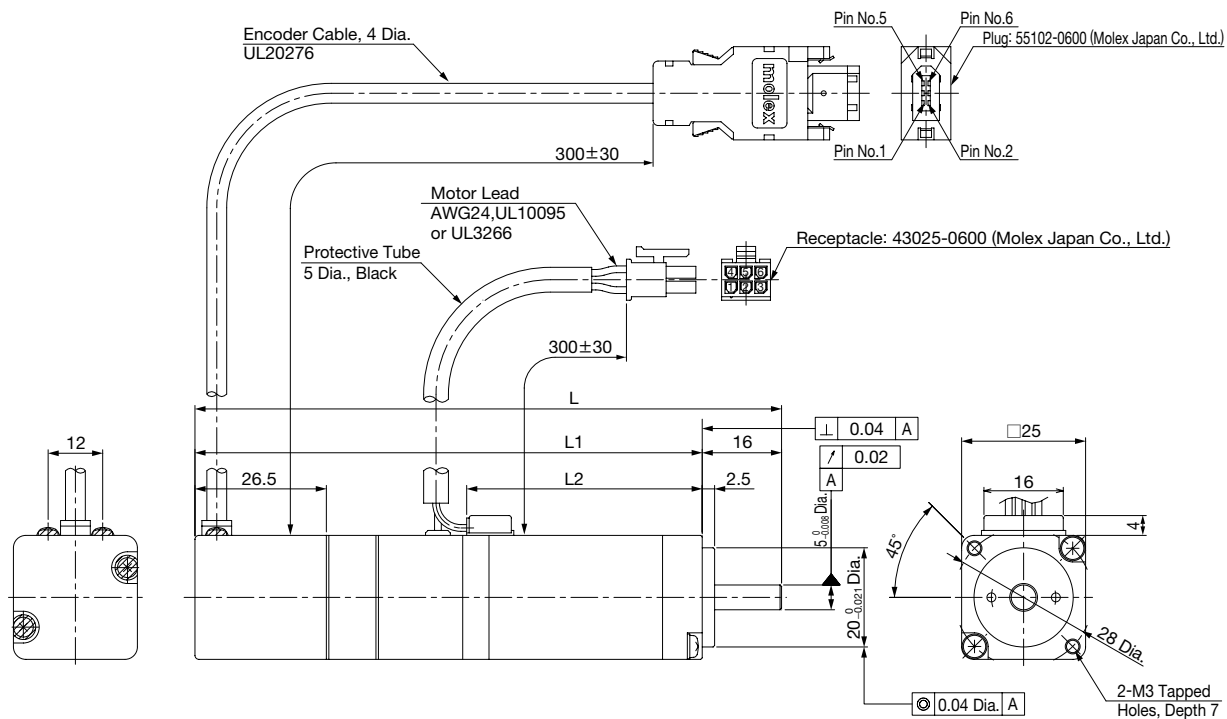

Model SGMMV-	L	L1	L2	Approx. Mass kg
A1□2A□C	94.5	78.5	27.5	0.215
A2□2A□C	108.5	92.5	37.5	0.27
A3□2A□C	118.5	102.5	47.5	0.31

### <Shaft End>

#### ● With a Flat Seat

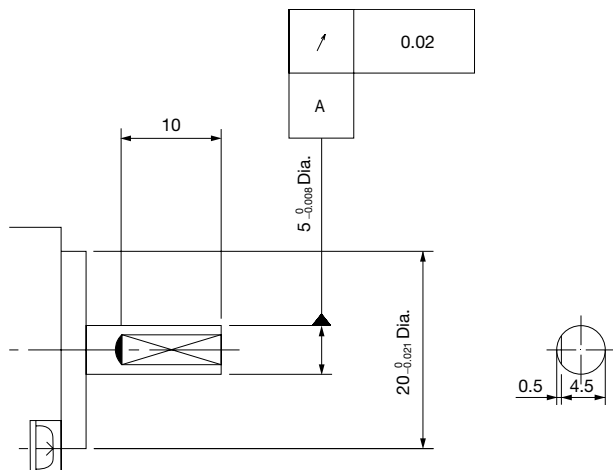

## Selecting Cables for SERVOPACKs with DC Power Input

### ● Examples of Cable Connections

#### ● Standard Wiring (Max. encoder cable length: 20 m)

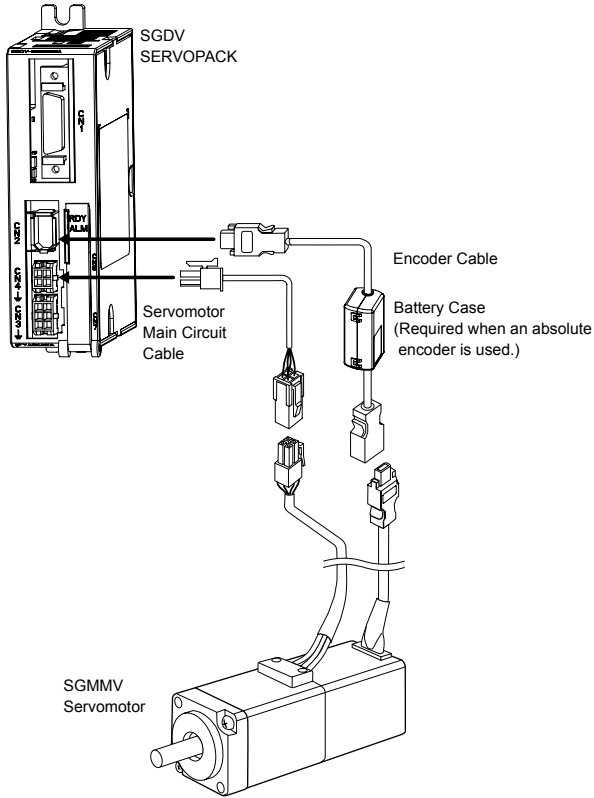

#### ● Encoder Cable Extension from 30 to 50 m

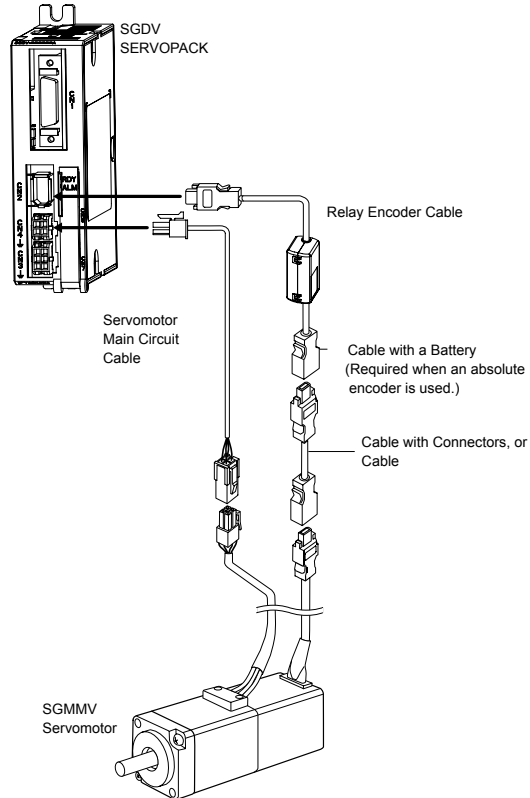

### ⚠ CAUTION

- Separate the servomotor main circuit cable wiring from the I/O signal cable and encoder cable at least 30 cm, and do not bundle or run them in the same duct.
- When the cable length exceeds 20 m, be sure to use a relay encoder cable.
- If the main circuit cable for the servomotor causes the line-to-line voltage to drop, the intermittent duty zone of the torque-motor speed characteristics may become smaller.

### ● Servomotor Main Circuit Cable

Name	Length	Order No.		Specifications	Details
		Standard Type	Flexible Type*		
For Servomotor without Holding Brakes	3 m	JZSP-CF1M00-03-E	JZSP-CF1M20-03-E		(1)
	5 m	JZSP-CF1M00-05-E	JZSP-CF1M20-05-E		
	10 m	JZSP-CF1M00-10-E	JZSP-CF1M20-10-E		
	15 m	JZSP-CF1M00-15-E	JZSP-CF1M20-15-E		
	20 m	JZSP-CF1M00-20-E	JZSP-CF1M20-20-E		
	30 m	JZSP-CF1M00-30-E	JZSP-CF1M20-30-E		
	40 m	JZSP-CF1M00-40-E	JZSP-CF1M20-40-E		
	50 m	JZSP-CF1M00-50-E	JZSP-CF1M20-50-E		
For Servomotor with Holding Brakes	3 m	JZSP-CF1M10-03-E	JZSP-CF1M30-03-E		(2)
	5 m	JZSP-CF1M10-05-E	JZSP-CF1M30-05-E		
	10 m	JZSP-CF1M10-10-E	JZSP-CF1M30-10-E		
	15 m	JZSP-CF1M10-15-E	JZSP-CF1M30-15-E		
	20 m	JZSP-CF1M10-20-E	JZSP-CF1M30-20-E		
	30 m	JZSP-CF1M10-30-E	JZSP-CF1M30-30-E		
	40 m	JZSP-CF1M10-40-E	JZSP-CF1M30-40-E		
	50 m	JZSP-CF1M10-50-E	JZSP-CF1M30-50-E		

\*: Use flexible cables for movable sections such as robot arms.

## Selecting Cables for SERVOPACKs with DC Power Input

### (1) Wiring Specifications for Servomotors without Holding Brakes



SERVOPACK End		Servomotor End	
Pin No.	Signal	Signal	Pin No.
1	Phase U	Phase U	1
2	Phase V	Phase V	2
3	Phase W	Phase W	3
4	FG	FG	4

### (2) Wiring Specifications for Servomotor with Holding Brakes

SERVOPACK End		Servomotor End	
Pin No.	Signal	Signal	Pin No.
1	Phase U	Phase U	1
2	Phase V	Phase V	2
3	Phase W	Phase W	3
4	FG	FG	4
Ring terminal	Brake	Brake	5
Ring terminal	Brake	Brake	6

Note: No polarity for connection to a holding brake.

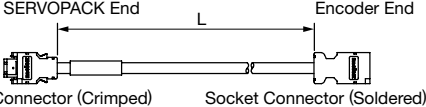
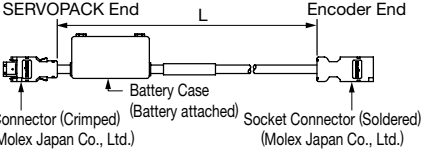
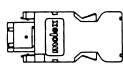
### ● Encoder Cables (Length: 20 m or less)

Name	Length	Order No.		Specifications	Details
		Standard Type	Flexible Type <sup>1</sup>		
Cable with Connectors (For Incremental Encoder)	3 m	JZSP-CMP00-03-E	JZSP-CMP10-03-E	 SERVOPACK End $L$ Encoder End Connector (Crimped) (Molex Japan Co., Ltd.) Socket Connector (Soldered) (Molex Japan Co., Ltd.)	(1)
	5 m	JZSP-CMP00-05-E	JZSP-CMP10-05-E		
	10 m	JZSP-CMP00-10-E	JZSP-CMP10-10-E		
	15 m	JZSP-CMP00-15-E	JZSP-CMP10-15-E		
	20 m	JZSP-CMP00-20-E	JZSP-CMP10-20-E		
Cable with Connectors <sup>2</sup> (For Absolute Encoder, with a Battery Case)	3 m	JZSP-CSP19-03-E	JZSP-CSP29-03-E	 SERVOPACK End $L$ Encoder End Connector (Crimped) (Molex Japan Co., Ltd.) Battery Case (Battery attached) Socket Connector (Soldered) (Molex Japan Co., Ltd.)	(2)
	5 m	JZSP-CSP19-05-E	JZSP-CSP29-05-E		
	10 m	JZSP-CSP19-10-E	JZSP-CSP29-10-E		
	15 m	JZSP-CSP19-15-E	JZSP-CSP29-15-E		
	20 m	JZSP-CSP19-20-E	JZSP-CSP29-20-E		
SERVOPACK-end Connector Kit		JZSP-CMP9-1-E		Soldered 	(3)
Encoder-end Connector Kit		JZSP-CMP9-2-E		Soldered 	
Cables	5 m	JZSP-CMP09-05-E	JZSP-CSP39-05-E	20 m Max. 	(4)
	10 m	JZSP-CMP09-10-E	JZSP-CSP39-10-E		
	15 m	JZSP-CMP09-15-E	JZSP-CSP39-15-E		
	20 m	JZSP-CMP09-20-E	JZSP-CSP39-20-E		

\*1: Use flexible cables for movable sections such as robot arms.

\*2: When the battery is connected to the host controller, no battery case is required. If so, use a cable for incremental encoders.

## Selecting Cables for SERVOPACKs with DC Power Input

### (1) Wiring Specifications for Cable with Connectors (For incremental encoder)

SERVOPACK End		Encoder (Servomotor) End		
Pin No.	Signal	Pin No.	Wire Color	
			Standard Type	Flexible Type
6	/PS	6	Light blue/white	Black/light blue
5	PS	5	Light blue	Red/light blue
4	BAT(-)	4	Orange/white	Black/pink
3	BAT(+)	3	Orange	Red/pink
2	PG 0V	2	Black	Green
1	PG 5V	1	Red	Orange
Shell	FG	Shell	FG	FG

### (2) Wiring Specifications for Cable with Connectors (For absolute encoder, with a battery case)

SERVOPACK End		Encoder (Servomotor) End		
Pin No.	Signal	Pin No.	Wire Color	
			Standard Type	Flexible Type
6	/PS	6	Light blue/white	Black/pink
5	PS	5	Light blue	Red/pink
4	BAT(-)	4	Orange/white	Black/light blue
3	BAT(+)	3	Orange	Red/light blue
2	PG 0V	2	Black	Green
1	PG 5V	1	Red	Orange
Shell	FG	Shell	FG	FG

Battery Case	
Pin No.	Signal
2	BAT(-)
1	BAT(+)

### (3) SERVOPACK-end/Encoder-end Connector Kit Specifications

Items	SERVOPACK-end Connector Kit	Encoder-end Connector Kit
Order No.	JZSP-CMP9-1-E (Cables are not included.)	JZSP-CMP9-2-E (Cables are not included.)
Manufacturer	Molex Japan Co., Ltd.	Molex Japan Co., Ltd.
Specifications	55100-0670 (soldered) Product Specification: PS-54280	54280-0609 (soldered) Product Specification: PS-54280
External Dimensions mm		

## Selecting Cables for SERVOPACKs with DC Power Input

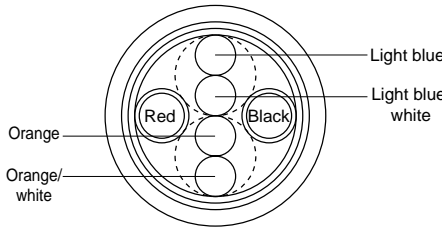
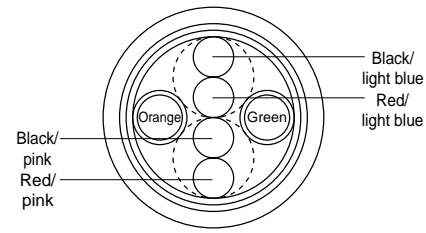

### (4) Cable Specifications

Items	Standard Type	Flexible Type
Order No.*	JZSP-CMP09-□□-E	JZSP-CSP39-□□-E
Cable Length	20 m max.	
Specifications	UL20276 (Rating temperature: 80°C) AWG22X2C+AWG24X2P AWG22 (0.33 mm <sup>2</sup> ) Outer diameter of insulating sheath: 1.15 dia. mm AWG24 (0.20 mm <sup>2</sup> ) Outer diameter of insulating sheath: 1.09 dia. mm	UL20276 (Rating temperature: 80°C) AWG22X2C+AWG24X2P AWG22 (0.33 mm <sup>2</sup> ) Outer diameter of insulating sheath: 1.35 dia. mm AWG24 (0.20 mm <sup>2</sup> ) Outer diameter of insulating sheath: 1.21 dia. mm
Finished Dimensions	6.5 dia. mm	6.8 dia. mm
Internal Configuration and Lead Color		
Yaskawa Standards Specifications (Standard Length)	Cable length: 5 m, 10 m, 15 m, 20 m	

\*: Specify the cable length in □□ of order no.  
 Example: JZSP-CMP09-05-E (5 m)

## Selecting Cables for SERVOPACKs with DC Power Input

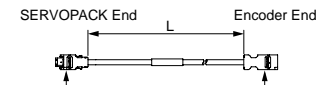
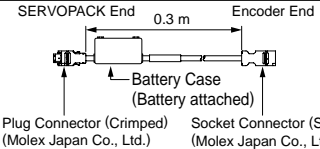
### ● Relay Encoder Cables (For extending from 30 to 50 m)

Name	Length	Order No. Standard Type	Specifications	Details
① Cable with Connectors (For incremental and absolute encoder)	30 m	JZSP-UCMP00-30-E		(1)
	40 m	JZSP-UCMP00-40-E		
	50 m	JZSP-UCMP00-50-E		
② Cable with a Battery Case (Required when an absolute encoder is used*)	0.3 m	JZSP-CSP12-E		(2)
③ Cables	30 m	JZSP-CMP19-30-E		(3)
	40 m	JZSP-CMP19-40-E		
	50 m	JZSP-CMP19-50-E		

\*: Not required when connecting a battery to the host controller.

#### (1) Wiring Specifications for Cable with Connectors

SERVOPACK End		Encoder (Servomotor) End	
Pin No.	Signal	Pin No.	Wire Color
6	/PS	6	Light blue/white
5	PS	5	Light blue
4	BAT (-)	4	Orange/white
3	BAT (+)	3	Orange
2	PG 0V	2	Black
1	PG 5V	1	Red
Shell	FG	Shell	FG



#### (2) Wiring Specifications for Cable with a Battery Case

SERVOPACK End		Encoder (Servomotor) End	
Pin No.	Signal	Pin No.	Wire Color
6	/PS	6	Light blue/white
5	PS	5	Light blue
4	BAT (-)	4	Orange/white
3	BAT (+)	3	Orange
2	PG 0V	2	Black
1	PG 5V	1	Red
Shell	FG	Shell	FG

Battery Case	
Pin No.	Signal
2	BAT (-)
1	BAT (+)

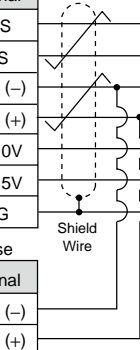

#### (3) Cable Specifications

Item	Standard Type
Order No.*	JZSP-CMP19-□□-E
Cable Length	50 m max.
Specifications	UL20276 (Rating temperature: 80°C) AWG16x2C+AWG26x2P AWG16 (1.31 mm <sup>2</sup> ) Outer diameter of insulating sheath: 2.0 dia. mm AWG26 (0.13 mm <sup>2</sup> ) Outer diameter of insulating sheath: 0.91 dia. mm
Finished Dimensions	6.8 dia. mm
Internal Configuration and Lead Colors	
Yaskawa Standard Specifications (Standard Length)	Cable length: 30 m, 40 m, 50 m

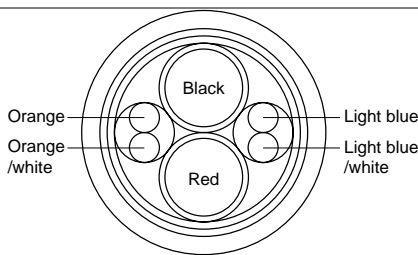
\*: Specify the cable length in □□ of order no.  
Example: JZSP-CMP19-30-E (30 m)



# Selecting Cables for SERVOPACKs with AC Power Input

## ● Examples of Cable Connections

● Standard Wiring (Max. encoder cable length: 20 m)

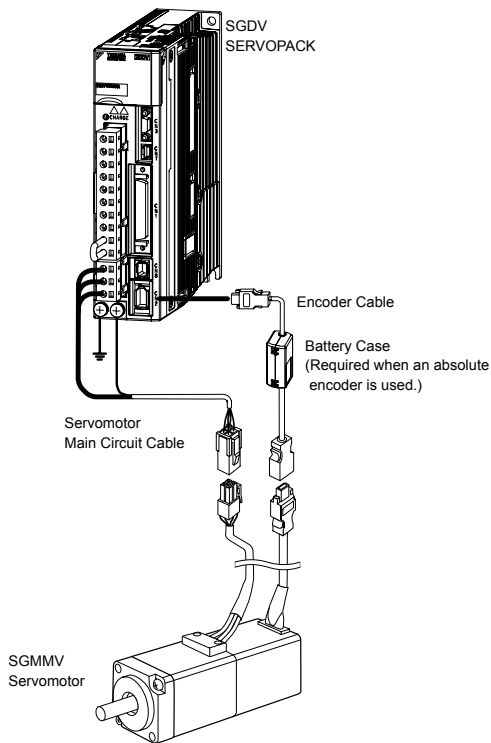

● Encoder Cable Extension from 30 to 50 m

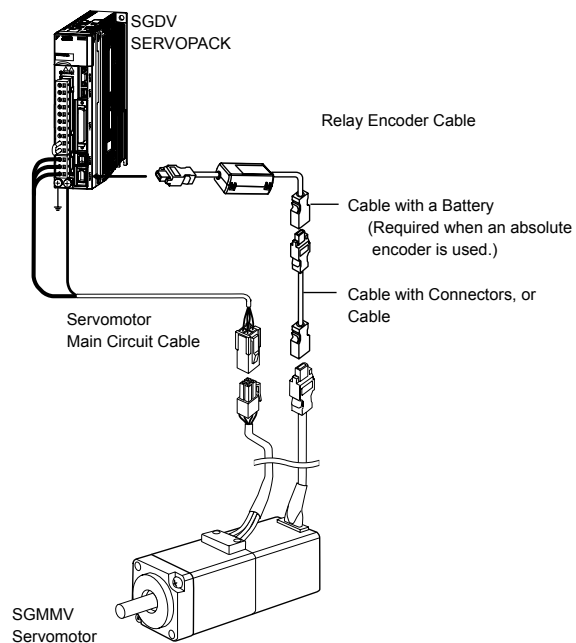

### ⚠ CAUTION

- Separate the servomotor main circuit cable wiring from the I/O signal cable and encoder cable at least 30 cm, and do not bundle or run them in the same duct.
- When the cable length exceeds 20 m, be sure to use a relay encoder cable.
- When the main circuit cable length exceeds 20 m, note that the intermittent duty zone of the Torque-Motor Speed Characteristics will shrink as the line-to-line voltage drops.

## ● Servomotor Main Circuit Cable

Name	Length	Order No.		Specifications	Details
		Standard Type	Flexible Type*		
For Servomotor without Holding Brakes	3 m	JZSP-CF2M00-03-E	JZSP-CF2M20-03-E		(1)
	5 m	JZSP-CF2M00-05-E	JZSP-CF2M20-05-E		
	10 m	JZSP-CF2M00-10-E	JZSP-CF2M20-10-E		
	15 m	JZSP-CF2M00-15-E	JZSP-CF2M20-15-E		
	20 m	JZSP-CF2M00-20-E	JZSP-CF2M20-20-E		
	30 m	JZSP-CF2M00-30-E	JZSP-CF2M20-30-E		
	40 m	JZSP-CF2M00-40-E	JZSP-CF2M20-40-E		
For Servomotor with Holding Brakes	3 m	JZSP-CF2M03-03-E	JZSP-CF2M23-03-E		(2)
	5 m	JZSP-CF2M03-05-E	JZSP-CF2M23-05-E		
	10 m	JZSP-CF2M03-10-E	JZSP-CF2M23-10-E		
	15 m	JZSP-CF2M03-15-E	JZSP-CF2M23-15-E		
	20 m	JZSP-CF2M03-20-E	JZSP-CF2M23-20-E		
	30 m	JZSP-CF2M03-30-E	JZSP-CF2M23-30-E		
	40 m	JZSP-CF2M03-40-E	JZSP-CF2M23-40-E		
50 m	JZSP-CF2M03-50-E	JZSP-CF2M23-50-E			

\*: Use flexible cables for movable sections such as robot arms.

## Selecting Cables for SERVOPACKs with AC Power Input

### (1) Wiring Specifications for Servomotors without Holding Brakes



SERVOPACK-end Leads		Servomotor-end Connector	
Wire Color	Signal	Signal	Pin No.
Red	Phase U	Phase U	1
White	Phase V	Phase V	2
Blue	Phase W	Phase W	3
Green/yellow	FG	FG	4

### (2) Wiring Specifications for Servomotor with Holding Brakes

SERVOPACK-end Leads		Servomotor-end Connector	
Wire Color	Signal	Signal	Pin No.
Red	Phase U	Phase U	1
White	Phase V	Phase V	2
Blue	Phase W	Phase W	3
Green/yellow	FG	FG	4
Black	Brake	Brake	5
Black	Brake	Brake	6

Note: No polarity for connection to a holding brake.

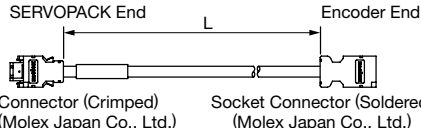
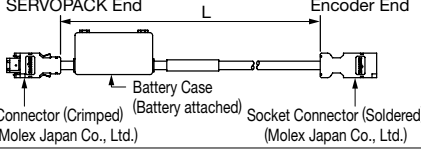
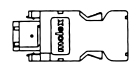
### ● Encoder Cables (Length: 20 m or less)

Name	Length	Order No.		Specifications	Details
		Standard Type	Flexible Type <sup>*1</sup>		
Cable with Connectors (For Incremental Encoder)	3 m	JZSP-CMP00-03-E	JZSP-CMP10-03-E		(1)
	5 m	JZSP-CMP00-05-E	JZSP-CMP10-05-E		
	10 m	JZSP-CMP00-10-E	JZSP-CMP10-10-E		
	15 m	JZSP-CMP00-15-E	JZSP-CMP10-15-E		
	20 m	JZSP-CMP00-20-E	JZSP-CMP10-20-E		
Cable with Connectors <sup>*2</sup> (For Absolute Encoder, with a Battery Case)	3 m	JZSP-CSP19-03-E	JZSP-CSP29-03-E		(2)
	5 m	JZSP-CSP19-05-E	JZSP-CSP29-05-E		
	10 m	JZSP-CSP19-10-E	JZSP-CSP29-10-E		
	15 m	JZSP-CSP19-15-E	JZSP-CSP29-15-E		
	20 m	JZSP-CSP19-20-E	JZSP-CSP29-20-E		
SERVOPACK-end Connector Kit		JZSP-CMP9-1-E		Soldered 	(3)
Encoder-end Connector Kit		JZSP-CMP9-2-E		Soldered 	
Cables	5 m	JZSP-CMP09-05-E	JZSP-CSP39-05-E	20 m Max. 	(4)
	10 m	JZSP-CMP09-10-E	JZSP-CSP39-10-E		
	15 m	JZSP-CMP09-15-E	JZSP-CSP39-15-E		
	20 m	JZSP-CMP09-20-E	JZSP-CSP39-20-E		

\*1: Use flexible cables for movable sections such as robot arms.

\*2: When the battery is connected to the host controller, no battery case is required. If so, use a cable for incremental encoders.

## Selecting Cables for SERVOPACKs with AC Power Input

### (1) Wiring Specifications for Cable with Connectors (For incremental encoder)

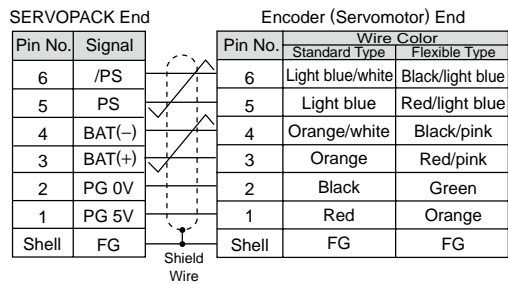

### (2) Wiring Specifications for Cable with Connectors (For absolute encoder, with a battery case)

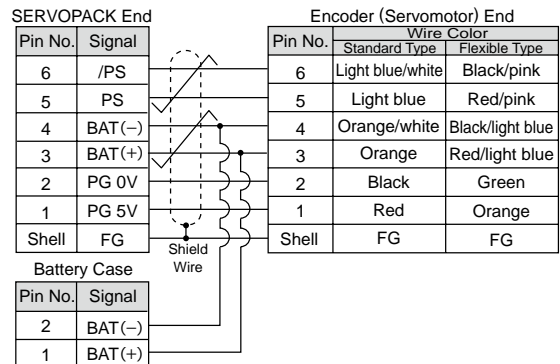

### (3) SERVOPACK-end/Encoder-end Connector Kit Specifications

Items	SERVOPACK-end Connector Kit	Encoder-end Connector Kit
Order No.	JZSP-CMP9-1-E (Cables are not included.)	JZSP-CMP9-2-E (Cables are not included.)
Manufacturer	Molex Japan Co., Ltd.	Molex Japan Co., Ltd.
Specifications	55100-0670 (soldered) Product Specification: PS-54280	54280-0609 (soldered) Product Specification: PS-54280
External Dimensions mm		

## Selecting Cables for SERVOPACKs with AC Power Input

### (4) Cable Specifications

Items	Standard Type	Flexible Type
Order No.*	JZSP-CMP09-□□-E	JZSP-CSP39-□□-E
Cable Length	20 m max.	
Specifications	UL20276 (Rating temperature: 80°C) AWG22X2C+AWG24X2P AWG22 (0.33 mm <sup>2</sup> ) Outer diameter of insulating sheath: 1.15 dia. mm AWG24 (0.20 mm <sup>2</sup> ) Outer diameter of insulating sheath: 1.09 dia. mm	UL20276 (Rating temperature: 80°C) AWG22X2C+AWG24X2P AWG22 (0.33 mm <sup>2</sup> ) Outer diameter of insulating sheath: 1.35 dia. mm AWG24 (0.20 mm <sup>2</sup> ) Outer diameter of insulating sheath: 1.21 dia. mm
Finished Dimensions	6.5 dia. mm	6.8 dia. mm
Internal Configuration and Lead Color		
Yaskawa Standards Specifications (Standard Length)	Cable length: 5 m, 10 m, 15 m, 20 m	

\*: Specify the cable length in □□ of order no.  
 Example: JZSP-CMP09-05-E (5 m)

## Selecting Cables for SERVOPACKs with AC Power Input

### ● Relay Encoder Cables (For extending from 30 to 50 m)

Name	Length	Order No. Standard Type	Specifications	Details
<input type="checkbox"/> Cable with Connectors (For incremental and absolute encoder)	30 m	JZSP-UCMP00-30-E		(1)
	40 m	JZSP-UCMP00-40-E		
	50 m	JZSP-UCMP00-50-E		
<input type="checkbox"/> Cable with a Battery Case (Required when an absolute encoder is used*)	0.3 m	JZSP-CSP12-E		(2)
<input type="checkbox"/> Cables	30 m	JZSP-CMP19-30-E		(3)
	40 m	JZSP-CMP19-40-E		
	50 m	JZSP-CMP19-50-E		

\*: Not required when connecting a battery to the host controller.

#### (1) Wiring Specifications for Cable with Connectors

SERVOPACK End		Encoder (Servomotor) End	
Pin No.	Signal	Pin No.	Wire Color
6	/PS	6	Light blue/white
5	PS	5	Light blue
4	BAT (-)	4	Orange/white
3	BAT (+)	3	Orange
2	PG 0V	2	Black
1	PG 5V	1	Red
Shell	FG	Shell	FG

#### (2) Wiring Specifications for Cable with a Battery Case

SERVOPACK End		Encoder (Servomotor) End	
Pin No.	Signal	Pin No.	Wire Color
6	/PS	6	Light blue/white
5	PS	5	Light blue
4	BAT (-)	4	Orange/white
3	BAT (+)	3	Orange
2	PG 0V	2	Black
1	PG 5V	1	Red
Shell	FG	Shell	FG

Battery Case	
Pin No.	Signal
2	BAT (-)
1	BAT (+)

#### (3) Cable Specifications

Item	Standard Type
Order No.*	JZSP-CMP19-□□-E
Cable Length	50 m max.
Specifications	UL20276 (Rating temperature: 80°C) AWG16x2C+AWG26x2P AWG16 (1.31 mm <sup>2</sup> ) Outer diameter of insulating sheath: 2.0 dia. mm AWG26 (0.13 mm <sup>2</sup> ) Outer diameter of insulating sheath: 0.91 dia. mm
Finished Dimensions	6.8 dia. mm
Internal Configuration and Lead Colors	
Yaskawa Standard Specifications (Standard Length)	Cable length: 30 m, 40 m, 50 m

\*: Specify the cable length in □□ of order no.  
 Example: JZSP-CMP19-30-E (30 m)

# SGMMV

# Rotary Servomotors

# SGMJV



## Model Designations

### ● Without Gears

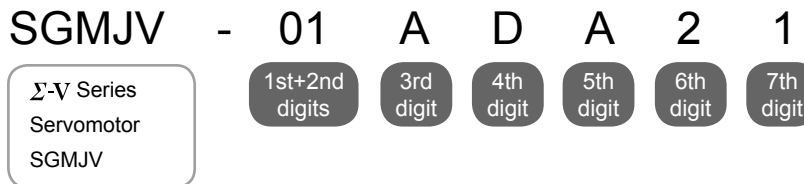

**1st+2nd digits** Rated Output

Code	Specifications
A5	50 W
01	100 W
C2	150 W
02	200 W
04	400 W
06	600 W
08	750 W

**3rd digit** Power Supply Voltage

Code	Specifications
A	200 VAC

**4th digit** Serial Encoder

Code	Specifications
3	20-bit absolute*
D	20-bit incremental
A	13-bit incremental

**5th digit** Design Revision Order

Code	Specifications
A	Standard

**6th digit** Shaft End

Code	Specifications
2	Straight without key
6	Straight with key and tap
B	With two flat seats

**7th digit** Options

Code	Specifications
1	Without options
C	With holding brake (24 VDC)
E	With oil seal and holding brake (24 VDC)
S	With oil seal

Limited Stock Items
  Non-Stock Items

\*: When exporting the servomotors themselves, export restrictions may apply. Follow each country's export restrictions.

## Features

- Medium inertia
- Instantaneous peak torque (350% of rated torque)
- Mounted high-resolution serial encoder: 13, 20 bits
- Maximum speed: 6,000 min<sup>-1</sup>
- Wide Selection: 50 to 750 W capacity, holding brake and gear options

## Application Examples

- Semiconductor equipment
- Chip mounters
- PCB drilling stations
- Robots
- Material handling machines
- Food processing equipment



# Ratings and Specifications

Time Rating: Continuous  
 Vibration Class: V15  
 Insulation Resistance: 500 VDC, 10 MΩ min.  
 Ambient Temperature: 0 to 40°C  
 Excitation: Permanent magnet  
 Mounting: Flange-mounted  
 Thermal Class: B

Withstand Voltage: 1500 VAC for one minute  
 Enclosure: Totally enclosed, self-cooled, IP65  
 (except for shaft opening)  
 Ambient Humidity: 20% to 80% (no condensation)  
 Drive Method: Direct drive  
 Rotation Direction: Counterclockwise (CCW) with forward run reference when viewed from the load side

Voltage		200 V						
Servomotor Model: SGMJV-□□□□		A5A	01A	C2A	02A	04A	06A	08A
Rated Output* <sup>1</sup>	W	50	100	150	200	400	600	750
Rated Torque* <sup>1, 2</sup>	N·m	0.159	0.318	0.477	0.637	1.27	1.91	2.39
Instantaneous Peak Torque* <sup>1</sup>	N·m	0.557	1.11	1.67	2.23	4.46	6.69	8.36
Rated Current* <sup>1</sup>	A <sub>rms</sub>	0.61	0.84	1.6	1.6	2.7	4.2	4.7
Instantaneous Max. Current* <sup>1</sup>	A <sub>rms</sub>	2.1	2.9	5.7	5.8	9.3	14.9	16.9
Rated Speed* <sup>1</sup>	min <sup>-1</sup>	3000						
Max. Speed* <sup>1</sup>	min <sup>-1</sup>	6000						
Torque Constant	N·m/A <sub>rms</sub>	0.285	0.413	0.327	0.435	0.512	0.505	0.544
Rotor Moment of Inertia	×10 <sup>-4</sup> kg·m <sup>2</sup>	0.0414 (0.0561)	0.0665 (0.0812)	0.0883 (0.103)	0.259 (0.323)	0.442 (0.506)	0.667 (0.744)	1.57 (1.74)
Rated Power Rate* <sup>1</sup>	kW/s	6.11	15.2	25.8	15.7	36.5	54.7	36.3
Rated Angular Acceleration* <sup>1</sup>	rad/s <sup>2</sup>	38400	47800	54100	24600	28800	28600	15200
Applicable SERVOPACK	SGDV-□□□□	R70□	R90□	1R6A,2R1F	1R6A,2R1F	2R8□	5R5A	5R5A

\*1: These items and torque-motor speed characteristics quoted in combination with an SGDV SERVOPACK are at an armature winding temperature of 100°C. Other values quoted are at 20°C.

\*2: Rated torques are continuous allowable torque values at 40°C with an aluminum heat sink of the following dimensions attached.

SGMJV-A5A, -01A: 200 mm×200 mm×6 mm

SGMJV-02A, -04A, -08A: 250 mm×250 mm×6 mm

Note: The values in parentheses are for servomotors with holding brakes.

## ● Torque-Motor Speed Characteristics A : Continuous Duty Zone B : Intermittent Duty Zone<sup>(Note3)</sup>

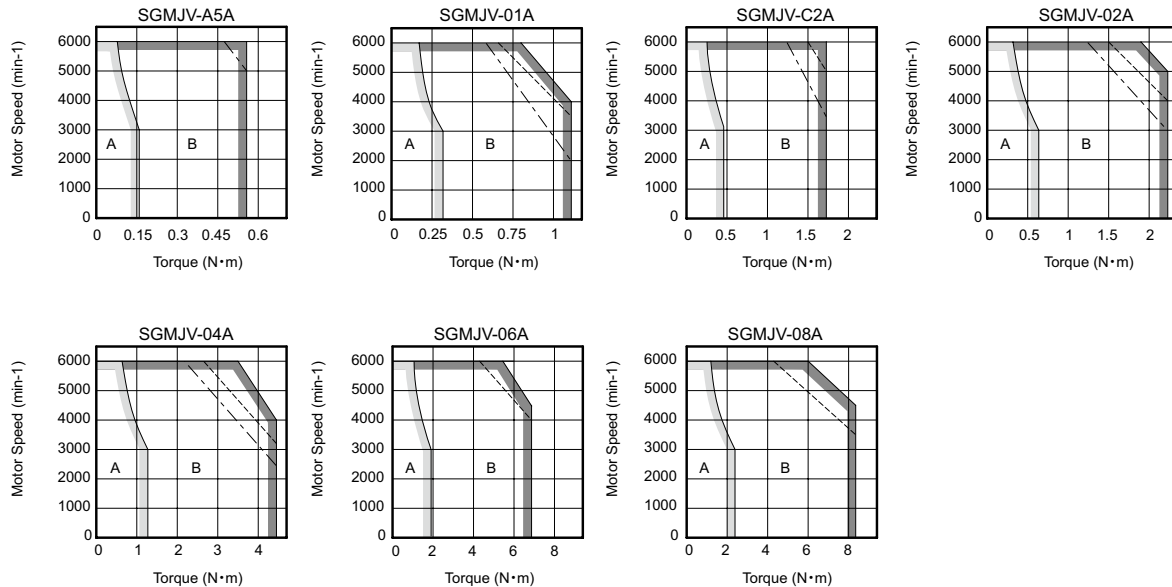

Notes: 1 The solid, dotted, and dashed-dotted lines of the intermittent duty zone indicate the characteristics when a servomotor runs with the following combinations:

- The solid line: With a three-phase 200 V or a single-phase 230 V SERVOPACK
- The dotted line: With a single-phase 200 V SERVOPACK
- The dashed-dotted line: With a single-phase 100 V SERVOPACK

An SGMJV-A5A servomotor has the same characteristics in combination with three-phase 200 V and single-phase 200 V SERVOPACKS.

2 The characteristics of the intermittent duty zone differ depending on the supply voltages.

3 When the effective torque during intermittent duty is within the rated torque, the servomotor can be used within the intermittent duty zone.

4 When the main circuit cable length exceeds 20 m, note that the intermittent duty zone of the Torque-Motor Speed Characteristics will shrink as the line-to-line voltage drops.

## Ratings and Specifications

### ● Derating Rate for Servomotor Fitted with an Oil Seal

When a motor is fitted with an oil seal, use the following derating rate because of the higher friction torque.

Servomotor Model SGMJV-	A5A	01A	02A	04A	08A
Derating Rate %	80	90		95	

### ● Holding Brake Electrical Specifications

Holding Brake Rated Voltage	Servomotor Model	Servomotor Rated Output W	Holding Brake Specifications					
			Capacity W	Holding Torque N·m	Coil Resistance $\Omega$ (at 20°C)	Rated Current A(at 20°C)	Brake Release Time ms	Brake Operation Time ms
24 VDC $^{+10\%}_0$	SGMJV-A5A	50	5.5	0.159	103	0.23	60	100
	SGMJV-01A	100	5.5	0.318	103	0.23	60	100
	SGMJV-C2A	150	5.5	0.477	104	0.23	60	100
	SGMJV-02A	200	6	0.637	97.4	0.25	60	100
	SGMJV-04A	400	6	1.27	97.4	0.25	60	100
	SGMJV-06A	600	6.5	1.91	88.6	0.27	80	100
	SGMJV-08A	750	6.5	2.39	87.7	0.27	80	100

Notes: 1 The holding brake is only used to hold the load and cannot be used to stop the servomotor.

2 The holding brake open time and holding brake operation time vary depending on which discharge circuit is used. Make sure holding brake open time and holding brake operation time are correct for your servomotor.

3 A 24-VDC power supply is provided by customers.

### ● Overload Characteristics

The overload detection level is set under hot start conditions at a servomotor ambient temperature of 40°C.

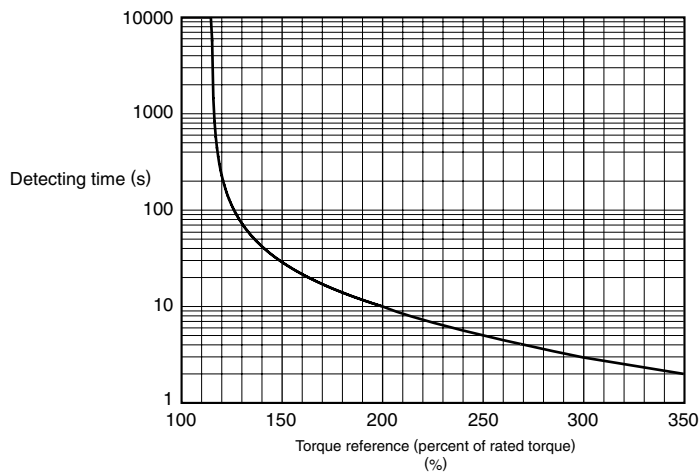

Note: Overload characteristics shown above do not guarantee continuous duty of 100% or more output. Use a servomotor with effective torque within the continuous duty zone of Torque-Motor Speed Characteristics.

## Ratings and Specifications

### ● Allowable Load Moment of Inertia at the Motor Shaft

The rotor moment of inertia ratio is the value for a servomotor without a gear and a holding brake.

Servomotor Model		Servomotor Rated Output	Allowable Load Moment of Inertia (Rotor Moment of Inertia Ratio)
SGMJV-	A5A, 01A, C2A	50, 100, 150W	20 times
	02A	200 W	15 times
	04A, 06A, 08A	400 to 750 W	10 times

### ● Load Moment of Inertia

- The larger the load moment of inertia, the worse the movement response.
- The allowable load moment of inertia ( $J_L$ ) depends on motor capacity, as shown above. This value is provided strictly as a guideline and results may vary depending on servomotor drive conditions.
- Use the AC servo drive capacity selection program SigmaJunmaSize+ to check the operation conditions. The program can be downloaded for free from our web site (<http://www.e-mechatronics.com/>).
- An overvoltage alarm (A.400) is likely to occur during deceleration if the load moment of inertia exceeds the allowable load moment of inertia. SERVOPACKs with a built-in regenerative resistor may generate a regenerative overload alarm (A.320). Take one of the following steps if this occurs.
  - Reduce the torque limit.
  - Reduce the deceleration rate.
  - Reduce the maximum speed.
  - Install an external regenerative resistor if the alarm cannot be cleared using the steps above. Refer to Regenerative Resistors on page 386.
- Regenerative resistors are not built into SERVOPACKs for 400 W motors or less.
- External regenerative resistors are required when this condition is exceeded or if the allowable loss capacity (W) of the built-in regenerative resistor is exceeded due to regenerative drive conditions when a regenerative resistor is already built in.

### ● Allowable Radial and Thrust Loads

Design the mechanical system so thrust and radial loads applied to the servomotor shaft end during operation fall within the ranges shown in the table.

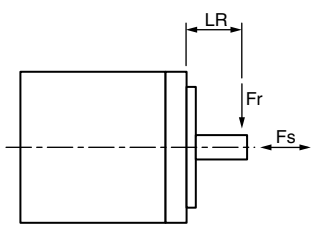
Servomotor Model		Allowable Radial Load ( $F_r$ ) N	Allowable Thrust Load ( $F_s$ ) N	LR mm	Reference Diagram
SGMJV-	A5A	78	54	20	
	01A				
	C2A				
	02A	245	74	25	
	04A				
	06A				
	08A				

**External Dimensions** Units: mm

(1) 50 to 150 W

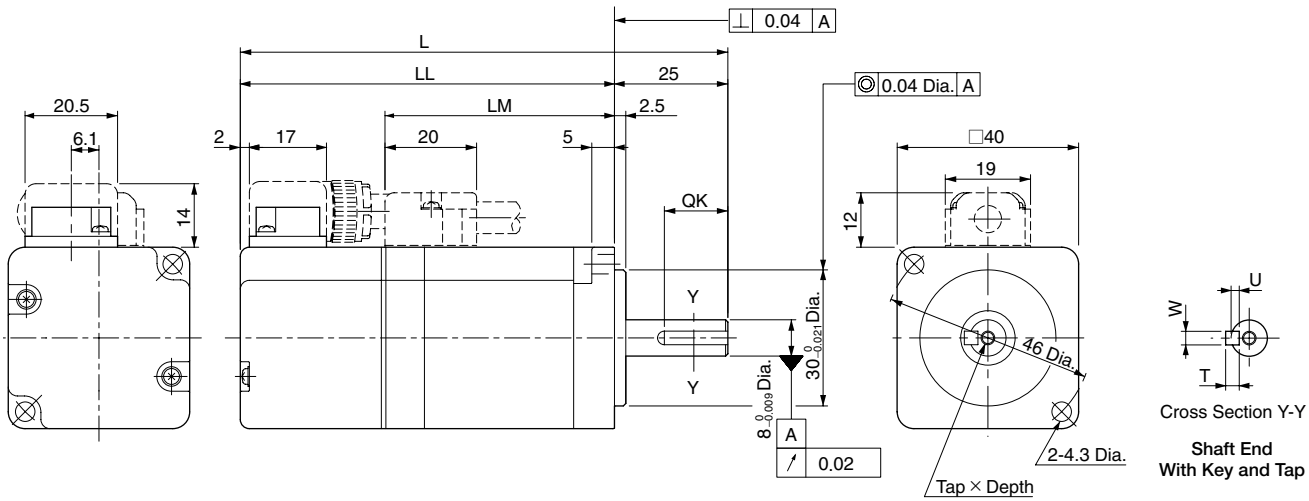

Model SGMJV-	L	LL	LM	Tap x Depth	Key Dimensions				Approx. Mass kg
					QK	U	W	T	
A5A□A21 (A5A□A2C)	94 (139)	69 (114)	37	No tap	No key				0.3 (0.6)
A5A□A61 (A5A□A6C)				M3 x 6L	14	1.8	3	3	
01A□A21 (01A□A2C)	107.5 (152.5)	82.5 (127.5)	50.5	No tap	No key				0.4 (0.7)
01A□A61 (01A□A6C)				M3 x 6L	14	1.8	3	3	
C2A□A21 (C2A□A2C)	119.5 (164.5)	94.5 (139.5)	62.5	No tap	No key				0.5 (0.8)
C2A□A61 (C2A□A6C)				M3 x 6L	14	1.8	3	3	

Note: The models and values in parentheses are for servomotors with holding brakes.

<Shaft End and Other Options>

● With Two Flat Seats

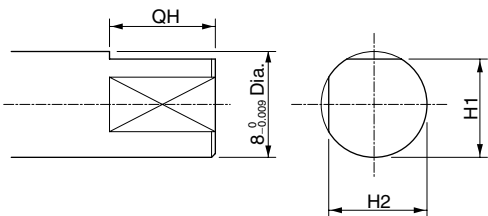

Model SGMJV-	Dimensions of Servomotor with Two Flat Seats mm		
	QH	H1	H2
A5A□AB□	15	7.5	7.5
01A□AB□			
C2A□AB□			

● With an Oil Seal

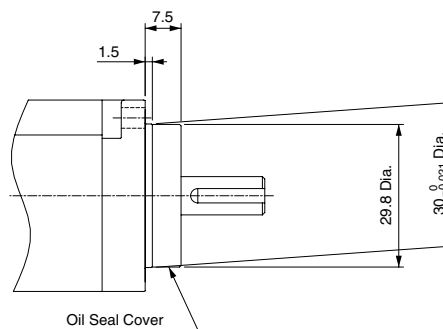

Notes: 1 The 7th digit of the model designation is "S" or "E."  
2 Key dimensions are the same as those in the table above.

# External Dimensions Units: mm

(2) 200 to 750 W

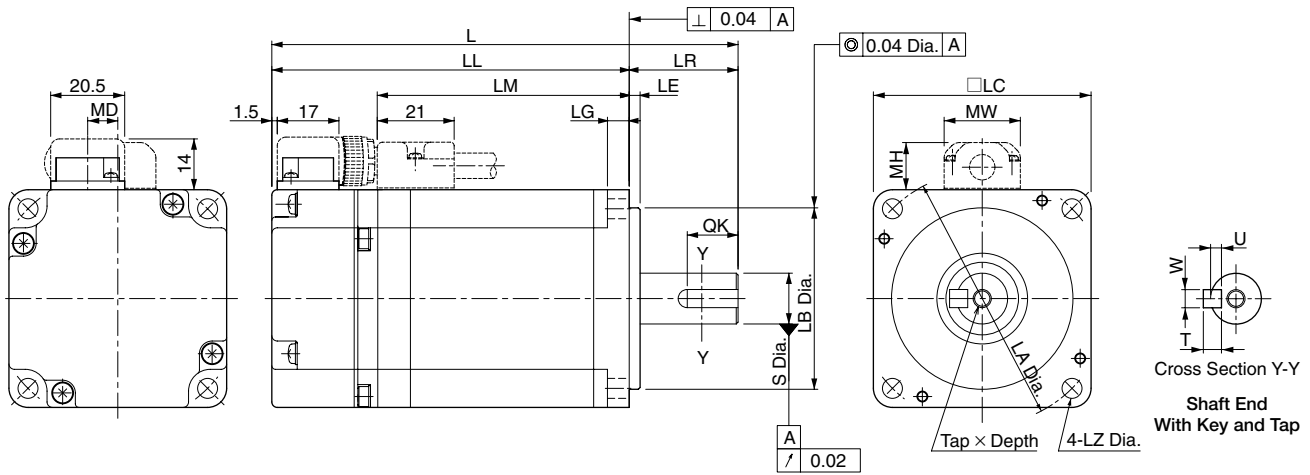

Model SGMJV-	L	LL	LM	Flange Face Dimensions							S	Tap×Depth	Key Dimensions				MD	MW	MH	Approx. Mass kg
				LR	LE	LG	LC	LA	LB	LZ			QK	U	W	T				
02A□A21 (02A□A2C)	110 (150)	80 (120)	51	30	3	6	60	70	50 <sup>0</sup> <sub>-0.025</sub>	5.5	14 <sup>0</sup> <sub>-0.011</sub>	No tap	No key				8.3	21	13	0.9 (1.5)
02A□A61 (02A□A6C)												M5×8L	14	3	5	5				
04A□A21 (04A□A2C)	128.5 (168.5)	98.5 (138.5)	69.5	30	3	6	60	70	50 <sup>0</sup> <sub>-0.025</sub>	5.5	14 <sup>0</sup> <sub>-0.011</sub>	No tap	No key				8.3	21	13	1.3 (1.9)
04A□A61 (04A□A6C)												M5×8L	14	3	5	5				
06A□A21 (06A□A2C)	154.5 (200.5)	124.5 (170.5)	95.5	30	3	6	60	70	50 <sup>0</sup> <sub>-0.025</sub>	5.5	14 <sup>0</sup> <sub>-0.011</sub>	No tap	No key				8.3	21	13	1.7 (2.4)
06A□A61 (06A□A6C)												M5×8L	14	3	5	5				
08A□A21 (08A□A2C)	155 (200)	115 (160)	85	40	3	8	80	90	70 <sup>0</sup> <sub>-0.030</sub>	7	19 <sup>0</sup> <sub>-0.013</sub>	No tap	No key				13.8	27	15	2.7 (3.6)
08A□A61 (08A□A6C)												M6×10L	22	3.5	6	6				

Note: The models and values in parentheses are for servomotors with holding brakes.

## <Shaft End and Other Options>

### ● With Two Flat Seats

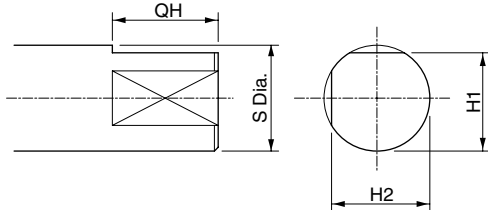

Model SGMJV-	Dimensions of Servomotor with Two Flat Seats mm			
	QH	S	H1	H2
02A□AB□	15	14 <sup>0</sup> <sub>-0.011</sub>	13	13
04A□AB□				
06A□AB□				
08A□AB□	22	19 <sup>0</sup> <sub>-0.013</sub>	18	18

### ● With an Oil Seal

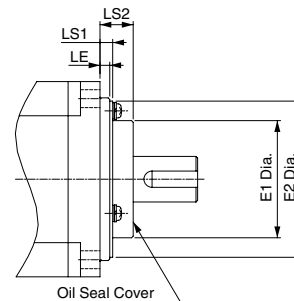

Model SGMJV-	Dimensions of Servomotor with an Oil Seal			
	E1	E2	LS1	LS2
02A, 04A, 06A	36	48	4	10
08A	49	66	6	11

Notes: 1 The 7th digit of the model designation is "S" or "E."  
2 Key dimensions are the same as those in the table above.

## Selecting Cables

### ● Cables Connections

- Standard Wiring (Max. encoder cable length: 20 m)

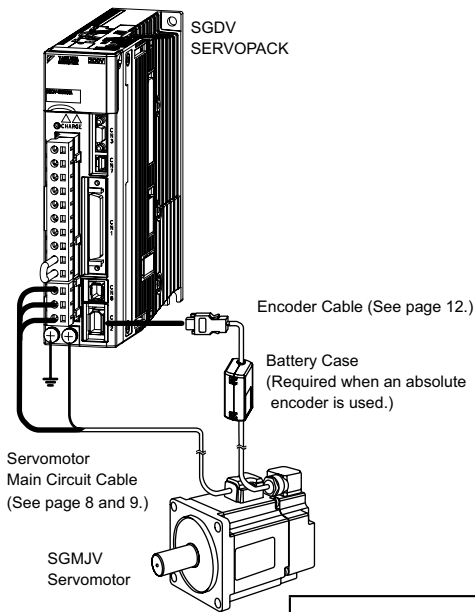

- Encoder Cable Extension from 30 to 50 m

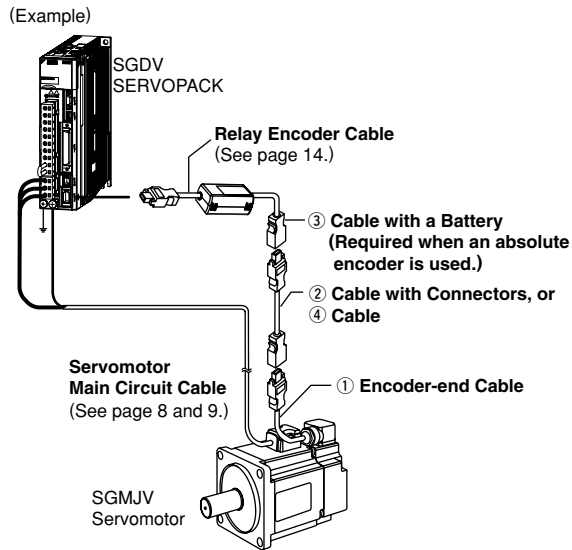

### ⚠ CAUTION

- Separate the servomotor main circuit cable wiring from the I/O signal cable and encoder cable at least 30 cm, and do not bundle or run them in the same duct.
- When the cable length exceeds 20 m, be sure to use a relay encoder cable.
- When the main circuit cable length exceeds 20 m, note that the intermittent duty zone of the Torque-Motor Speed Characteristics will shrink as the line-to-line voltage drops.

### ● Servomotor Main Circuit Cable

Name	Servomotor Rated Output	Length	Order No.			Specifications	Details
			Standard Type	Flexible Type*	Premium Type*		
For Servomotor without Holding Brakes	50 to 150 W	3 m	JZSP-CSM01-03-E	JZSP-CSM21-03-E	YAI-CSM21-03-P-E		(1)
		5 m	JZSP-CSM01-05-E	JZSP-CSM21-05-E	YAI-CSM21-05-P-E		
		10 m	JZSP-CSM01-10-E	JZSP-CSM21-10-E	YAI-CSM21-10-P-E		
		15 m	JZSP-CSM01-15-E	JZSP-CSM21-15-E	YAI-CSM21-15P-E		
		20 m	JZSP-CSM01-20-E	JZSP-CSM21-20-E	YAI-CSM21-20-P-E		
		30 m	JZSP-CSM01-30-E	JZSP-CSM21-30-E	YAI-CSM21-30-P-E		
		40 m	JZSP-CSM01-40-E	JZSP-CSM21-40-E	YAI-CSM21-40-P-E		
	50 m	JZSP-CSM01-50-E	JZSP-CSM21-50-E	YAI-CSM21-50-P-E			
	200 to 600 W	3 m	JZSP-CSM02-03-E	JZSP-CSM22-03-E	YAI-CSM22-03-P-E		
		5 m	JZSP-CSM02-05-E	JZSP-CSM22-05-E	YAI-CSM22-05-P-E		
		10 m	JZSP-CSM02-10-E	JZSP-CSM22-10-E	YAI-CSM22-10-P-E		
		15 m	JZSP-CSM02-15-E	JZSP-CSM22-15-E	YAI-CSM22-15P-E		
		20 m	JZSP-CSM02-20-E	JZSP-CSM22-20-E	YAI-CSM22-20-P-E		
		30 m	JZSP-CSM02-30-E	JZSP-CSM22-30-E	YAI-CSM22-30-P-E		
		40 m	JZSP-CSM02-40-E	JZSP-CSM22-40-E	YAI-CSM22-40-P-E		
	50 m	JZSP-CSM02-50-E	JZSP-CSM22-50-E	YAI-CSM22-50-P-E			
	750 W	3 m	JZSP-CSM03-03-E	JZSP-CSM23-03-E	YAI-CSM23-03-P-E		
		5 m	JZSP-CSM03-05-E	JZSP-CSM23-05-E	YAI-CSM23-05-P-E		
		10 m	JZSP-CSM03-10-E	JZSP-CSM23-10-E	YAI-CSM23-10-P-E		
		15 m	JZSP-CSM03-15-E	JZSP-CSM23-15-E	YAI-CSM23-15P-E		
		20 m	JZSP-CSM03-20-E	JZSP-CSM23-20-E	YAI-CSM23-20-P-E		
		30 m	JZSP-CSM03-30-E	JZSP-CSM23-30-E	YAI-CSM23-30-P-E		
		40 m	JZSP-CSM03-40-E	JZSP-CSM23-40-E	YAI-CSM23-40-P-E		
	50 m	JZSP-CSM03-50-E	JZSP-CSM23-50-E	YAI-CSM23-50-P-E			

(Cont'd)

# Selecting Cables

Name	Servomotor Rated Output	Length	Order No.			Specifications	Details			
			Standard Type	Flexible Type*	Premium Type*					
For Servomotor with Holding Brakes	50 to 150 W	3 m	JZSP-CSM11-03-E	JZSP-CSM31-03-E	YAI-CSM31-03-P-E		(2)			
		5 m	JZSP-CSM11-05-E	JZSP-CSM31-05-E	YAI-CSM31-05-P-E					
		10 m	JZSP-CSM11-10-E	JZSP-CSM31-10-E	YAI-CSM31-10-P-E					
		15 m	JZSP-CSM11-15-E	JZSP-CSM31-15-E	YAI-CSM31-15-P-E					
		20 m	JZSP-CSM11-20-E	JZSP-CSM31-20-E	YAI-CSM31-20-P-E					
		30 m	JZSP-CSM11-30-E	JZSP-CSM31-30-E	YAI-CSM31-30-P-E					
		40 m	JZSP-CSM11-40-E	JZSP-CSM31-40-E	YAI-CSM31-40-P-E					
		50 m	JZSP-CSM11-50-E	JZSP-CSM31-50-E	YAI-CSM31-50-P-E					
	200 to 600 W	3 m	JZSP-CSM12-03-E	JZSP-CSM32-03-E	YAI-CSM32-03-P-E					
		5 m	JZSP-CSM12-05-E	JZSP-CSM32-05-E	YAI-CSM32-05-P-E					
		10 m	JZSP-CSM12-10-E	JZSP-CSM32-10-E	YAI-CSM32-10-P-E					
		15 m	JZSP-CSM12-15-E	JZSP-CSM32-15-E	YAI-CSM32-15-P-E					
		20 m	JZSP-CSM12-20-E	JZSP-CSM32-20-E	YAI-CSM32-20-P-E					
		30 m	JZSP-CSM12-30-E	JZSP-CSM32-30-E	YAI-CSM32-30-P-E					
		40 m	JZSP-CSM12-40-E	JZSP-CSM32-40-E	YAI-CSM32-40-P-E					
		50 m	JZSP-CSM12-50-E	JZSP-CSM32-50-E	YAI-CSM32-50-P-E					
	750 W	3 m	JZSP-CSM13-03-E	JZSP-CSM33-03-E	YAI-CSM33-03-P-E					
		5 m	JZSP-CSM13-05-E	JZSP-CSM33-05-E	YAI-CSM33-05-P-E					
		10 m	JZSP-CSM13-10-E	JZSP-CSM33-10-E	YAI-CSM33-10-P-E					
		15 m	JZSP-CSM13-15-E	JZSP-CSM33-15-E	YAI-CSM33-15-P-E					
		20 m	JZSP-CSM13-20-E	JZSP-CSM33-20-E	YAI-CSM33-20-P-E					
		30 m	JZSP-CSM13-30-E	JZSP-CSM33-30-E	YAI-CSM33-30-P-E					
		40 m	JZSP-CSM13-40-E	JZSP-CSM33-40-E	YAI-CSM33-40-P-E					
		50 m	JZSP-CSM13-50-E	JZSP-CSM33-50-E	YAI-CSM33-50-P-E					
	Servomotor-end Connector Kit	50, 100, 150 W	JZSP-CSM9-1-E					N/A	Crimping Type (A crimp tool is required.)	(3)
		200, 400, 600 W	JZSP-CSM9-2-E					N/A		(4)
		750 W	JZSP-CSM9-3-E					N/A		(5)
	Cables	50 to 400 W	5 m	JZSP-CSM90-05-E	JZSP-CSM80-05-E			N/A		(6)
10 m			JZSP-CSM90-10-E	JZSP-CSM80-10-E	N/A					
15 m			JZSP-CSM90-15-E	JZSP-CSM80-15-E	N/A					
20 m			JZSP-CSM90-20-E	JZSP-CSM80-20-E	N/A					
30 m			JZSP-CSM90-30-E	JZSP-CSM80-30-E	N/A					
40 m			JZSP-CSM90-40-E	JZSP-CSM80-40-E	N/A					
50 m			JZSP-CSM90-50-E	JZSP-CSM80-50-E	N/A					
750 W			5 m	JZSP-CSM91-05-E	JZSP-CSM81-05-E	N/A	(7)			
10 m		JZSP-CSM91-10-E	JZSP-CSM81-10-E	N/A						
15 m		JZSP-CSM91-15-E	JZSP-CSM81-15-E	N/A						
20 m		JZSP-CSM91-20-E	JZSP-CSM81-20-E	N/A						
30 m		JZSP-CSM91-30-E	JZSP-CSM81-30-E	N/A						
40 m		JZSP-CSM91-40-E	JZSP-CSM81-40-E	N/A						
50 m		JZSP-CSM91-50-E	JZSP-CSM81-50-E	N/A						

\*: Use flexible or premium cables for movable sections such as robot arms.

## (1) Wiring Specifications for Servomotors without Holding Brakes

SERVOPACK-end Leads		Servomotor-end Connector	
Wire Color	Signal	Signal	Pin No.
Green/yellow	FG	FG	1
Blue	Phase W	Phase W	2
White	Phase V	Phase V	3
Red	Phase U	Phase U	4
-	-	-	5
-	-	-	6
(Shield)*	FG	FG	Shell

\* Shield wire only on Premium Type Cables, and is accessible if cable jacket is removed.

## (2) Wiring Specifications for Servomotor with Holding Brakes

SERVOPACK-end Leads		Servomotor-end Connector	
Wire Color	Signal	Signal	Pin No.
Green/yellow	FG	FG	1
Blue	Phase W	Phase W	2
White	Phase V	Phase V	3
Red	Phase U	Phase U	4
Black	Brake	Brake	5
Black	Brake	Brake	6
(Shield)*	FG	FG	Shell

Note: No polarity for connection to a holding brake.  
\*Shield wire only on premium-type cables, and is accessible if cable jacket is removed.

## Selecting Cables

### (3) Servomotor-end Connector Kit Specifications: For 50 to 150 W Servomotors

Items		Specifications	External Dimensions mm
Order No.	JZSP-CSM9-1-E (Cables are not included.)		
Applicable Servomotors	SGMJV-A5A, -01A		
Manufacturer	J.S.T. Mfg. Co., Ltd.		
Receptacle	J17-06FMH-7KL-1-CF		
Electrical Contact	SJ1F-01GF-P0.8		
Applicable Wire Size	AWG20 to 24		
Outer Diameter of Insulating Sheath	1.11 dia. to 1.53 dia. mm		
Crimp Tool	Hand tool	YRS-8841	
	Applicator	APLMK SJ1F/M-01-08	
Mounting Screw	M2 Pan-head screw		
Applicable Cable Outer Diameter	7±0.3 dia. mm		

### (4) Servomotor-end Connector Kit Specifications: For 200 to 600 W Servomotors

Items		Specifications	External Dimensions mm
Order No.	JZSP-CSM9-2-E (Cables are not included.)		
Applicable Servomotors	SGMJV-02A, -04A		
Manufacturer	J.S.T. Mfg. Co., Ltd.		
Receptacle	J27-06FMH-7KL-1-CF		
Electrical Contact	SJ2F-01GF-P1.0		
Applicable Wire Size	AWG20 to 24		
Outer Diameter of Insulating Sheath	1.11 dia. to 1.53 dia. mm		
Crimp Tool	Hand tool	YRS-8861	
	Applicator	APLMK SJ2F/M-01-08	
Mounting Screw	M2 Pan-head screw		
Applicable Cable Outer Diameter	7±0.3 dia. mm		

### (5) Servomotor-end Connector Kit Specifications: For 750 W Servomotors

Items		Specifications		External Dimensions mm	
Order No.	JZSP-CSM9-3-E (Cables are not included.)				
Applicable Servomotors	SGMJV-08A				
Manufacturer	J.S.T. Mfg. Co., Ltd.				
Receptacle	J37-06FMH-8KL-1-CF				
Cable Type	Standard				
Electrical Contact	SJ3F-41GF-P1.8 (For power terminals)	SJ3F-01GF-P1.8 (For brake terminals)			
Applicable Wire Size	AWG16 to 20	AWG20 to 24			
Outer Diameter of Insulating Sheath	1.53 dia. to 2.5 dia. mm	1.11 dia. to 1.86 dia. mm			
Crimp Tool	Hand tool	YRF-880	YRF-881		
	Applicator	APLMK SF3F/M-41-20	APLMK SF3F/M-01-20		
Mounting Screw	M2.5 Pan-head screw				
Applicable Cable Outer Diameter	8±0.3 dia. mm				



## Selecting Cables

### (6) Cable Specifications: For 50 to 600 W Servomotors

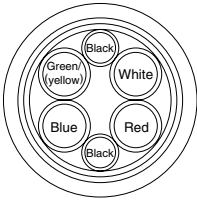
Items	Standard Type	Flexible Type
Order No.*	JZSP-CSM90-□□-E (50 m max.)	JZSP-CSM80-□□-E (50 m max.)
Specifications	UL2517 (Max. operating temperature: 105°C) AWG20×6C For power line: AWG20 (0.52 mm <sup>2</sup> ) Outer diameter of insulating sheath: 1.53 dia. mm For holding brake line: AWG20 (0.52 mm <sup>2</sup> ) Outer diameter of insulating sheath: 1.53 dia. mm	UL2517 (Max. operating temperature: 105°C) AWG22×6C For power line: AWG22 (0.33 mm <sup>2</sup> ) Outer diameter of insulating sheath: 1.37 dia. mm For holding brake line: AWG22 (0.33 mm <sup>2</sup> ) Outer diameter of insulating sheath: 1.37 dia. mm
Finished Dimensions	7±0.3 dia. mm	
Internal Configuration and Lead Color		
Yaskawa Standard Specifications (Standard Length)	Cable length: 5 m, 10 m, 15 m, 20 m, 30 m, 40 m, 50 m	

\*: Specify the cable length in □□ of order no.  
Example: JZSP-CSM90-05-E (5 m)

### (7) Cable Specifications: For 750 W Servomotors

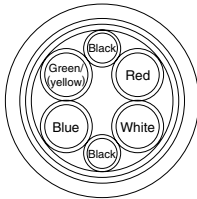
Items	Standard Type	Flexible Type
Order No.*	JZSP-CSM91-□□-E (50 m max.)	JZSP-CSM81-□□-E (50 m max.)
Specifications	UL2517 (Max. operating temperature: 105°C) AWG16×4C, AWG20×2C For power line: AWG16 (1.31 mm <sup>2</sup> ) Outer diameter of insulating sheath: 2.15 dia. mm For holding brake line: AWG20 (0.52 mm <sup>2</sup> ) Outer diameter of insulating sheath: 1.6 dia. mm	UL2517 (Max. operating temperature: 105°C) AWG16×4C, AWG22×2C For power line: AWG16 (1.31 mm <sup>2</sup> ) Outer diameter of insulating sheath: 2.35 dia. mm For holding brake line: AWG22 (0.33 mm <sup>2</sup> ) Outer diameter of insulating sheath: 1.37 dia. mm
Finished Dimensions	8±0.3 dia. mm	
Internal Configuration and Lead Color		
Yaskawa Standard Specifications (Standard Length)	Cable length: 5 m, 10 m, 15 m, 20 m, 30 m, 40 m, 50 m	

\*: Specify the cable length in □□ of order no.  
Example: JZSP-CSM91-05-E (5 m)

Selecting Cables

● Encoder Cables (Length: 20 m or less)

Name	Length	Order No.		Specifications	Details
		Standard Type	Flexible Type*		
Cable with Connectors (For Incremental Encoder)	3 m	JZSP-CSP01-03-E	JZSP-CSP21-03-E		(1)
	5 m	JZSP-CSP01-05-E	JZSP-CSP21-05-E		
	10 m	JZSP-CSP01-10-E	JZSP-CSP21-10-E		
	15 m	JZSP-CSP01-15-E	JZSP-CSP21-15-E		
	20 m	JZSP-CSP01-20-E	JZSP-CSP21-20-E		
Cable with Connectors (For Absolute Encoder, with a Battery Case)	3 m	JZSP-CSP05-03-E	JZSP-CSP25-03-E		(2)
	5 m	JZSP-CSP05-05-E	JZSP-CSP25-05-E		
	10 m	JZSP-CSP05-10-E	JZSP-CSP25-10-E		
	15 m	JZSP-CSP05-15-E	JZSP-CSP25-15-E		
	20 m	JZSP-CSP05-20-E	JZSP-CSP25-20-E		
SERVOPACK-end Connector Kit		JZSP-CMP9-1-E		Soldered	(3)
Encoder-end Connector Kit		JZSP-CSP9-2-E		Crimping Type (A crimping tool is required)	
Cables	3 m	JZSP-CMP09-03-E	JZSP-CSP39-03-E		(4)
	5 m	JZSP-CMP09-05-E	JZSP-CSP39-05-E		
	10 m	JZSP-CMP09-10-E	JZSP-CSP39-10-E		
	15 m	JZSP-CMP09-15-E	JZSP-CSP39-15-E		
	20 m	JZSP-CMP09-20-E	JZSP-CSP39-20-E		

\*: Use flexible cables for movable sections such as robot arms.

Note: When the battery from the host controller is used for the absolute encoder, no battery case is required. In this case, use a cable for the incremental encoders.

(1) Wiring Specifications for Cable with Connectors  
(For incremental encoder)

• Standard Type

Pin No.	Signal	Pin No.	Wire Color
6	/PS	5	Light blue/white
5	PS	4	Light blue
4	BAT (-)	8	Orange/white
3	BAT (+)	9	Orange
2	PG 0V	3	Black
1	PG 5V	6	Red
Shell	FG	Shell	FG

• Flexible Type

Pin No.	Signal	Pin No.	Wire Color
6	/PS	5	Black/pink
5	PS	4	Red/pink
4	BAT (-)	8	Black/light blue
3	BAT (+)	9	Red/light blue
2	PG 0V	3	Green
1	PG 5V	6	Orange
Shell	FG	Shell	FG

(2) Wiring Specifications for Cable with Connectors  
(For absolute encoder, with a battery case)

• Standard Type

Pin No.	Signal	Pin No.	Wire Color
6	/PS	5	Light blue/white
5	PS	4	Light blue
4	BAT (-)	8	Orange/white
3	BAT (+)	9	Orange
2	PG 0V	3	Black
1	PG 5V	6	Red
Shell	FG	Shell	FG

Battery Case	
Pin No.	Signal
2	BAT (-)
1	BAT (+)

• Flexible Type

Pin No.	Signal	Pin No.	Wire Color
6	/PS	5	Black/pink
5	PS	4	Red/pink
4	BAT (-)	8	Black/light blue
3	BAT (+)	9	Red/light blue
2	PG 0V	3	Green
1	PG 5V	6	Orange
Shell	FG	Shell	FG

Battery Case	
Pin No.	Signal
2	BAT (-)
1	BAT (+)

# Selecting Cables

## (3) SERVOPACK-end/Encoder-end Connector Kit Specifications

Items	SERVOPACK-end Connector Kit	Encoder-end Connector Kit
Order No.	JZSP-CMP9-1-E (Cables are not included.)	JZSP-CSP9-2-E (Cables are not included.)
Manufacturer	Molex Japan Co., Ltd.	Molex Japan Co., Ltd.
Specifications	55100-0670 (soldered)	54346-0070 (crimped)* Mounting screw: M2 pan-head screw (× 2) Applicable cable outer diameter of applicable cable: 6.3 dia. to 7.7 dia. mm Applicable wire size: AWG22 to 26 Outer diameter of insulating sheath: 1.05 dia. to 1.4 dia. mm
External Dimensions (Units: mm)		

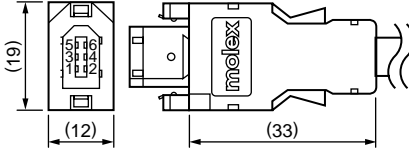
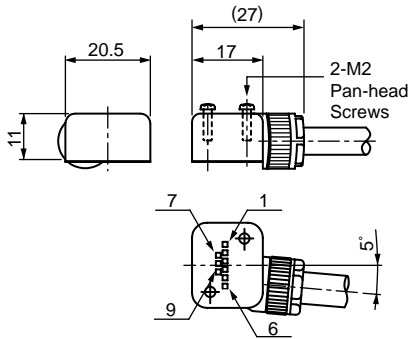
\*: A crimp tool is required.  
The following crimp tools are applicable for the cables provided by Yaskawa. When using other wire sizes, contact the respective manufacturer for crimp tools.  
Applicable crimp tool for Yaskawa's wire size: Hand Tool Model No. 57175-5000  
Applicator Model No. 57175-3000

## (4) Cable Specifications

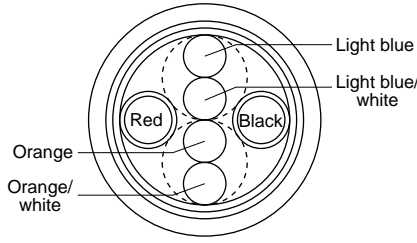
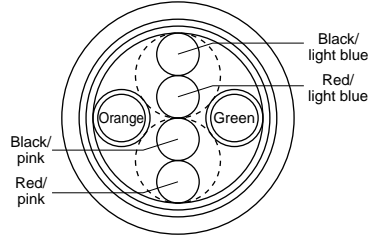
Items	Standard Type	Flexible Type
Order No.*	JZSP-CMP09-□□-E	JZSP-CSP39-□□-E
Cable Length	20 m max.	
Specifications	UL20276 (Max. operating temperature: 80°C) AWG22×2C+AWG24×2P AWG22 (0.33 mm <sup>2</sup> ) Outer diameter of insulating sheath: 1.15 dia. mm AWG24 (0.20 mm <sup>2</sup> ) Outer diameter of insulating sheath: 1.09 dia. mm	UL20276 (Max. operating temperature: 80°C) AWG22×2C+AWG24×2P AWG22 (0.33 mm <sup>2</sup> ) Outer diameter of insulating sheath: 1.35 dia. mm AWG24 (0.20 mm <sup>2</sup> ) Outer diameter of insulating sheath: 1.21 dia. mm
Finished Dimensions	6.5 dia. mm	6.8 dia. mm
Internal Configuration and Lead Color		
Yaskawa Standards Specifications (Standard Length)	Cable length: 5 m, 10 m, 15 m, 20 m	

\*: Specify the cable length in □□ of order no.  
Example: JZSP-CSP09-05-E (5 m)

## Selecting Cables

### ● Relay Encoder Cables (For extending from 30 to 50 m)

Name	Length	Order No.	Specifications	Details
		Standard Type		
① Encoder-end Cables (For incremental and absolute encoder)	0.3 m	JZSP-CSP11-E	<p>SERVOPACK End 0.3 m Encoder End Plug Connector (Crimped) (Molex Japan Co., Ltd.) Connector (Molex Japan Co., Ltd.)</p>	(1)
② Cable with Connectors (For incremental and absolute encoder)	30 m	JZSP-UCMP00-30-E	<p>SERVOPACK End Encoder End Plug Connector (Crimped) (Molex Japan Co., Ltd.) Socket Connector (Soldered) (Molex Japan Co., Ltd.)</p>	(2)
	40 m	JZSP-UCMP00-40-E		
	50 m	JZSP-UCMP00-50-E		
③ Cable with a Battery Case (Required when an absolute encoder is used.)	0.3 m	JZSP-CSP12-E*	<p>SERVOPACK End 0.3 m Encoder End Battery Case (Battery attached) Plug Connector (Crimped) (Molex Japan Co., Ltd.) Socket Connector (Soldered) (Molex Japan Co., Ltd.)</p>	(3)
④ Cables	30 m	JZSP-CMP19-30-E		(4)
	40 m	JZSP-CMP19-40-E		
	50 m	JZSP-CMP19-50-E		

\*: When using an incremental encoder or using an absolute encoder with a battery connected to the host controller, no battery case is required.

#### (1) Wiring Specifications for Encoder-end Cable

SERVOPACK End		Encoder (Servomotor) End	
Pin No.	Signal	Pin No.	Wire Color
6	/PS	5	Light blue/white
5	PS	4	Light blue
4	BAT (-)	8	Orange/white
3	BAT (+)	9	Orange
2	PG 0V	3	Black
1	PG 5V	6	Red
Shell	FG	Shell	FG

#### (2) Wiring Specifications for Cable with Connectors

SERVOPACK End		Encoder (Servomotor) End	
Pin No.	Signal	Pin No.	Wire Color
6	/PS	6	Light blue/white
5	PS	5	Light blue
4	BAT (-)	4	Orange/white
3	BAT (+)	3	Orange
2	PG 0V	2	Black
1	PG 5V	1	Red
Shell	FG	Shell	FG

#### (3) Wiring Specifications for Cable with a Battery Case

SERVOPACK End		Encoder (Servomotor) End	
Pin No.	Signal	Pin No.	Wire Color
6	/PS	6	Light blue/white
5	PS	5	Light blue
4	BAT (-)	4	Orange/white
3	BAT (+)	3	Orange
2	PG 0V	2	Black
1	PG 5V	1	Red
Shell	FG	Shell	FG

Battery Case	
Pin No.	Signal
2	BAT (-)
1	BAT (+)

#### (4) Cable Specifications

Item	Standard Type
Order No.*	JZSP-CMP19-□□-E
Cable Length	50 m max.
Specifications	UL20276 (Max. operating temperature: 80°C) AWG16×2C+AWG26×2P AWG16 (1.31 mm <sup>2</sup> ) Outer diameter of insulating sheath: 2.0 dia. mm AWG26 (0.13 mm <sup>2</sup> ) Outer diameter of insulating sheath: 0.91 dia. mm
Finished Dimensions	6.8 dia. mm
Internal Configuration and Lead Colors	
Yaskawa Standard Specifications (Standard Length)	Cable length: 30 m, 40 m, 50 m

\*: Specify the cable length in □□ of order no.  
Example: JZSP-CMP19-30-E (30 m)

# Rotary Servomotors

# SGMAV



## Model Designations

### ● Without Gears

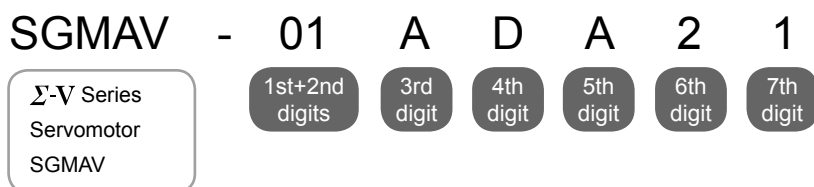

#### 1st+2nd digits Rated Output

Code	Specifications
A5	50 W
01	100 W
C2	150 W
02	200 W
04	400 W
06	550 W
08	750 W
10	1.0 kW

#### 5th digit Design Revision Order

Code	Specifications
A	Standard

#### 7th digit Options

Code	Specifications
1	Without options
C	With holding brake (24 VDC)
E	With oil seal and holding brake (24 VDC)
S	With oil seal

#### 6th digit Shaft End

Code	Specifications
2	Straight without key
6	Straight with key and tap
B	With two flat seats

#### 3rd digit Power Supply Voltage

Code	Specifications
A	200 VAC

NOTE: Shaded items are non-stock.

#### 4th digit Serial Encoder

Code	Specifications
3	20-bit absolute *
D	20-bit incremental

\*: When exporting the servomotors themselves, export restrictions may apply. Follow each country's export restrictions.

## Features

---

- Super high power rate (Extremely low inertia)
- Instantaneous peak torque (300% of rated torque)
- Mounted high-resolution serial encoder:  
20 bits
- Maximum speed: 6,000 min<sup>-1</sup>
- Wide selection: 50 W to 1.0 kW capacity, holding  
brake and gear options

## Application Examples

---

- Semiconductor equipment
- Chip mounters
- PCB drilling stations
- Robots
- Material handling machines
- Food processing equipment



# Ratings and Specifications

Time Rating: Continuous  
 Vibration Class: V15  
 Insulation Resistance: 500 VDC, 10 MΩ min.  
 Ambient Temperature: 0 to 40°C  
 Excitation: Permanent magnet  
 Mounting: Flange-mounted  
 Thermal Class: B

Withstand Voltage: 1500 VAC for one minute  
 Enclosure: Totally enclosed, self-cooled, IP65  
 (except for shaft opening)  
 Ambient Humidity: 20% to 80% (no condensation)  
 Drive Method: Direct drive  
 Rotation Direction: Counterclockwise (CCW) with forward run  
 reference when viewed from the load side

Voltage		200 V							
Servomotor Model: SGM <sub>AV</sub> -□□□□		A5A	01A	C2A	02A	04A	06A	08A	10A
Rated Output <sup>*1</sup>	W	50	100	150	200	400	550	750	1000
Rated Torque <sup>*1, *2</sup>	N·m	0.159	0.318	0.477	0.637	1.27	1.75	2.39	3.18
Instantaneous Peak Torque <sup>*1</sup>	N·m	0.477	0.955	1.43	1.91	3.82	5.25	7.16	9.55
Rated Current <sup>*1</sup>	A <sub>rms</sub>	0.66	0.91	1.3	1.5	2.6	3.8	5.3	7.4
Instantaneous Max. Current <sup>*1</sup>	A <sub>rms</sub>	2.1	2.8	4.2	5.3	8.5	12.2	16.6	23.9
Rated Speed <sup>*1</sup>	min <sup>-1</sup>	3000							
Max. Speed <sup>*1</sup>	min <sup>-1</sup>	6000							
Torque Constant	N·m/A <sub>rms</sub>	0.265	0.375	0.381	0.450	0.539	0.496	0.487	0.467
Rotor Moment of Inertia	×10 <sup>-4</sup> kg·m <sup>2</sup>	0.0242 (0.0389)	0.0380 (0.0527)	0.0531 (0.0678)	0.116 (0.180)	0.190 (0.254)	0.326 (0.403)	0.769 (0.940)	1.20 (1.41)
Rated Power Rate <sup>*1</sup>	kW/s	10.4	26.6	42.8	35.0	84.9	93.9	74.1	84.3
Rated Angular Acceleration <sup>*1</sup>	rad/s <sup>2</sup>	65800	83800	89900	54900	67000	53700	31000	26500
Applicable SERVOPACK	SGDV-□□□□□	R70□	R90□	1R6A,2R1F		2R8□	5R5A	5R5A	120A

\*1: These items and torque-motor speed characteristics quoted in combination with an SGDV SERVOPACK are at an armature winding temperature of 100°C. Other values quoted are at 20°C.

\*2: Rated torques are continuous allowable torque values at 40°C with an aluminum heat sink of the following dimensions attached.  
 SGM<sub>AV</sub>-A5A, -01A: 200 mm×200 mm×6 mm  
 SGM<sub>AV</sub>-C2A, -02A, -04A, -06A, -08A: 250 mm×250 mm×6 mm  
 SGM<sub>AV</sub>-10A: 300 mm×300 mm×12 mm

Note: The values in parentheses are for servomotors with holding brakes.

## ● Torque-Motor Speed Characteristics A: Continuous Duty Zone B: Intermittent Duty Zone<sup>(See Note3)</sup>

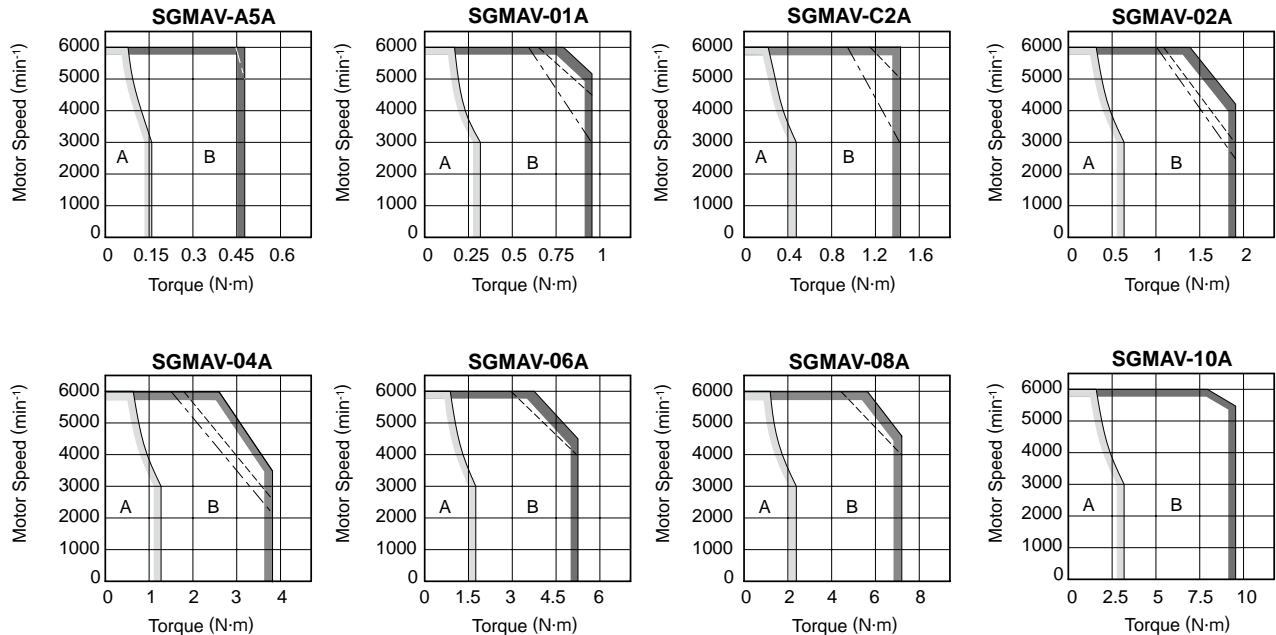

Notes: 1 The solid, dotted, and dashed-dotted lines of the intermittent duty zone indicate the characteristics when a servomotor runs with the following combinations:

- The solid line: With a three-phase 200 V or a single-phase 230 V SERVOPACK
- The dotted line: With a single-phase 200 V SERVOPACK
- The dashed-dotted line: With a single-phase 100 V SERVOPACK

An SGM<sub>AV</sub>-A5A servomotor has the same characteristics in combination with three-phase 200 V and single-phase 200 V SERVOPACKS.

- 2 The characteristics of the intermittent duty zone differ depending on the supply voltages.
- 3 When the effective torque during intermittent duty is within the rated torque, the servomotor can be used within the intermittent duty zone.
- 4 When the main circuit cable length exceeds 20 m, note that the intermittent duty zone of the Torque-Motor Speed Characteristics will shrink as the line-to-line voltage drops.

## Ratings and Specifications

### ● Derating Rate for Servomotor Fitted with an Oil Seal

When a motor is fitted with an oil seal, use the following derating rate because of the higher friction torque.

Servomotor Model SGMVA-	A5A	01A	C2A	02A	04A	06A	08A	10A
Derating Rate %	80	90			95			

### ● Holding Brake Electrical Specifications

Holding Brake Rated Voltage	Servomotor Model	Servomotor Rated Output W	Holding Brake Specifications					
			Capacity W	Holding Torque N·m	Coil Resistance Ω(at 20°C)	Rated Current A(at 20°C)	Brake Release Time ms	Brake Operation Time ms
24 VDC <sup>+10%</sup> <sub>0</sub>	SGMAV-A5A	50	5.5	0.159	103	0.23	60	100
	SGMAV-01A	100		0.318				
	SGMAV-C2A	150	5.1	0.477	114	0.21	60	100
	SGMAV-02A	200	6	0.637	97.4	0.25	60	100
	SGMAV-04A	400		1.27				
	SGMAV-06A	550	8	1.75	74.3	0.32	80	100
	SGMAV-08A	750	6.5	2.39	87.7	0.27	80	100
	SGMAV-10A	1000	7	3.18	82.8	0.29	80	100

- Notes: 1 The holding brake is only used to hold the load and cannot be used to stop the servomotor.  
 2 The holding brake open time and holding brake operation time vary depending on which discharge circuit is used. Make sure holding brake open time and holding brake operation time are correct for your servomotor.  
 3 A 24-VDC power supply is provided by customers.

### ● Overload Characteristics

The overload detection level is set under hot start conditions at a servomotor ambient temperature of 40°C.

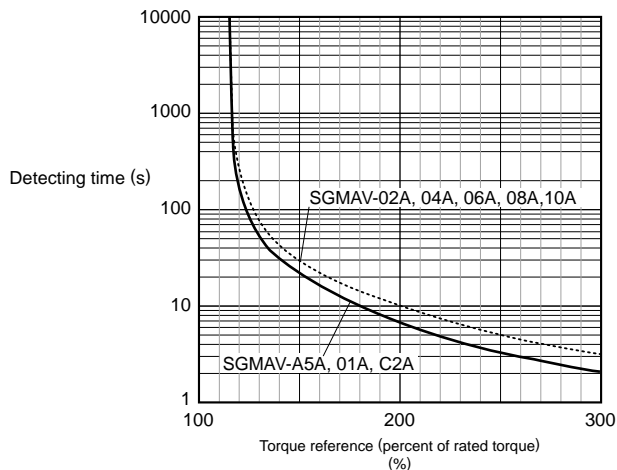

Note: Overload characteristics shown above do not guarantee continuous duty of 100% or more output. Use a servomotor with effective torque within the continuous duty zone of Torque-Motor Speed Characteristics.

## Ratings and Specifications

### ● Allowable Load Moment of Inertia at the Motor Shaft

The rotor moment of inertia ratio is the value for a servomotor without a gear and a brake.

Servomotor Model		Servomotor Rated Output	Allowable Load Moment of Inertia (Rotor Moment of Inertia Ratio)
SGMAV-	A5A, 01A, C2A, 02A	50 to 200 W	30 times
	04A, 06A, 08A	400 to 750 W	20 times
	10A	1000 W	10 times

### ● Load Moment of Inertia

- The larger the load moment of inertia, the worse the movement response.
- The allowable load moment of inertia ( $J_L$ ) depends on motor capacity, as shown above. This value is provided strictly as a guideline and results may vary depending on servomotor drive conditions.
- Use the AC servo drive capacity selection program SigmaJunmaSize+ to check the operation conditions. The program can be downloaded for free from our web site (<http://www.e-mechatronics.com/>).
- An overvoltage alarm (A.400) is likely to occur during deceleration if the load moment of inertia exceeds the allowable load moment of inertia. SERVOPACKs with a built-in regenerative resistor may generate a regenerative overload alarm (A.320). Take one of the following steps if this occurs.
  - Reduce the torque limit.
  - Reduce the deceleration rate.
  - Reduce the maximum speed.
  - Install an external regenerative resistor if the alarm cannot be cleared using the steps above. Refer to Regenerative Resistors on page 386.
- Regenerative resistors are not built into SERVOPACKs for 400 W motors or less.
- External regenerative resistors are required when this condition is exceeded or if the allowable loss capacity (W) of the built-in regenerative resistor is exceeded due to regenerative drive conditions when a regenerative resistor is already built in.

### ● Allowable Radial and Thrust Loads

Design the mechanical system so thrust and radial loads applied to the servomotor shaft end during operation fall within the ranges shown in the table.

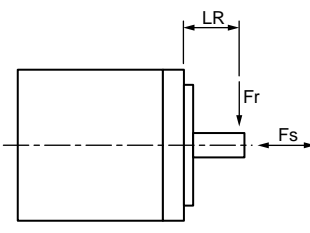
Servomotor Model		Allowable Radial Load ( $F_r$ ) N	Allowable Thrust Load ( $F_s$ ) N	LR mm	Reference Diagram
SGMAV-	A5A	78	54	20	
	01A				
	C2A				
	02A	245	74	25	
	04A				
	06A				
	08A				
	10A	392	147	35	

**External Dimensions** Units: mm

(1) 50 to 150 W

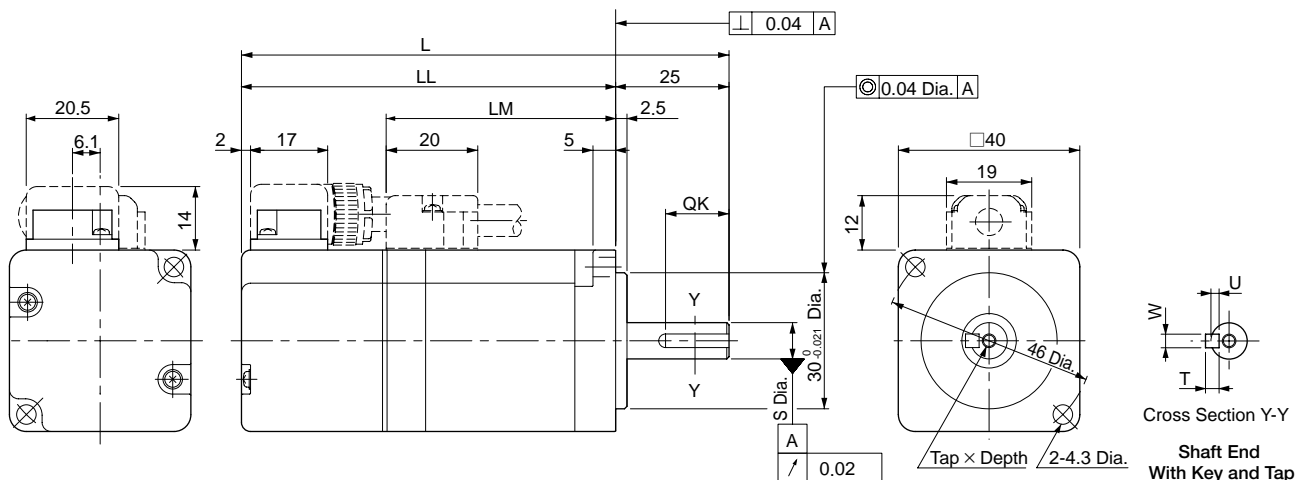

Model SGMAV-	L	LL	LM	S	Tap × Depth	Key Dimensions				Approx. Mass kg
						QK	U	W	T	
A5A□A21 (A5A□A2C)	95.5 (140.5)	70.5 (115.5)	38.5	8 <sup>0</sup> <sub>-0.009</sub> *	No tap	No key				0.3 (0.6)
A5A□A61 (A5A□A6C)					M3×6L	14	1.8	3	3	
01A□A21 (01A□A2C)	107.5 (152.5)	82.5 (127.5)	50.5	8 <sup>0</sup> <sub>-0.009</sub>	No tap	No key				0.4 (0.7)
01A□A61 (01A□A6C)					M3×6L	14	1.8	3	3	
C2A□A21 (C2A□A2C)	119.5 (164.5)	94.5 (139.5)	62.5	8 <sup>0</sup> <sub>-0.009</sub>	No tap	No key				0.5 (0.8)
C2A□A61 (C2A□A6C)					M3×6L	14	1.8	3	3	

Note: The models and values in parentheses are for servomotors with holding brakes.

\*: When you need the same shaft diameter as the conventional servomotors, contact your Yaskawa representative.

**Shaft End and Other Options**

● With Two Flat Seats

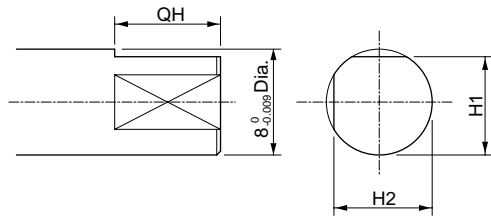

Model SGMAV-	Dimensions of Servomotor with Two Flat Seats		
	QH	H1	H2
A5A□AB□	15	7.5	7.5
01A□AB□			
C2A□AB□			

● With an Oil Seal

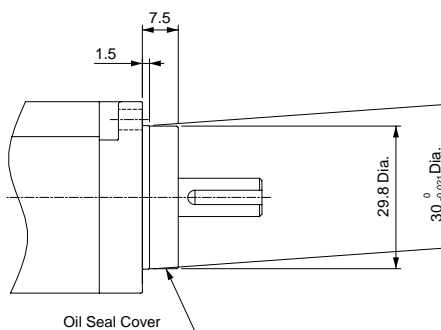

Note: The 7th digit of the model designation is "S" or "E."  
The key dimensions are the same as those in the table above.

# External Dimensions Units: mm

(2) 200 W to 1.0 kW

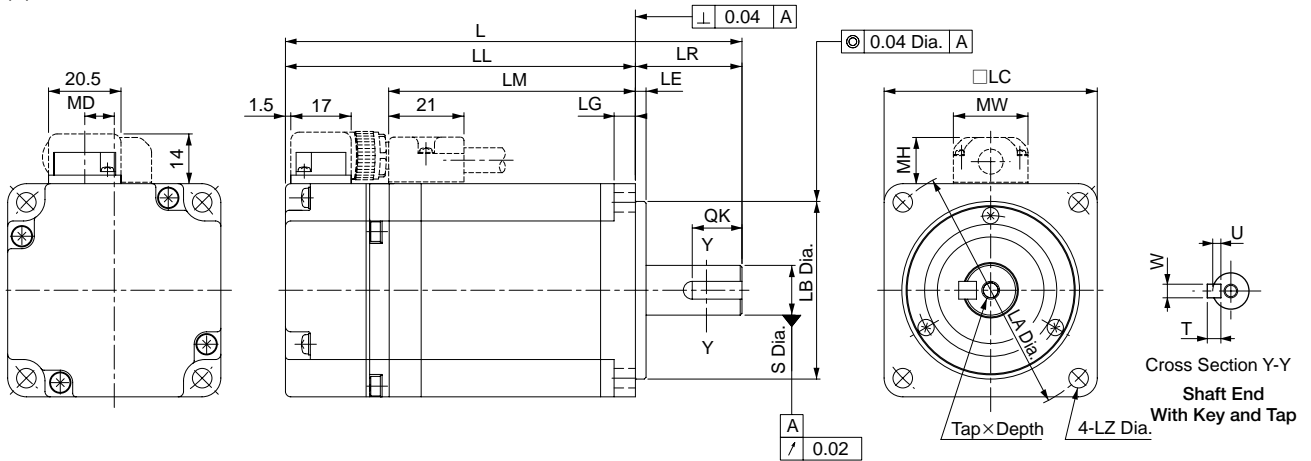

Model SGMAV-	L	LL	LM	Flange Face Dimensions								S	Tap x Depth	Key Dimensions				MD	MW	MH	Approx. Mass kg
				LR	LE	LG	LC	LA	LB	LZ	QK			U	W	T					
02A□A21 (02A□A2C)	110 (150)	80 (120)	51	30	3	6	60	70	50 <sup>0</sup> <sub>-0.025</sub>	5.5	14 <sup>0</sup> <sub>-0.011</sub>	No tap	No key				8.5	21	13	0.9 (1.5)	
02A□A61 (02A□A6C)												M5 x 8L	14	3	5	5					
04A□A21 (04A□A2C)	128.5 (168.5)	98.5 (138.5)	69.5	30	3	6	60	70	50 <sup>0</sup> <sub>-0.025</sub>	5.5	14 <sup>0</sup> <sub>-0.011</sub>	No tap	No key				8.5	21	13	1.2 (1.8)	
04A□A61 (04A□A6C)												M5 x 8L	14	3	5	5					
06A□A21 (06A□A2C)	154.5 (200.5)	124.5 (170.5)	95.5	30	3	6	60	70	50 <sup>0</sup> <sub>-0.025</sub>	5.5	14 <sup>0</sup> <sub>-0.011</sub>	No tap	No key				8.5	21	13	1.7 (2.4)	
06A□A61 (06A□A6C)												M5 x 8L	14	3	5	5					
08A□A21 (08A□A2C)	155 (200)	115 (160)	85	40	3	8	80	90	70 <sup>0</sup> <sub>-0.030</sub>	7	19 <sup>0</sup> <sub>-0.013</sub> *	No tap	No key				13.8	27	15	2.6 (3.2)	
08A□A61 (08A□A6C)												M6 x 10L	22	3.5	6	6					
10A□A21 (10A□A2C)	185 (235)	145 (195)	115	40	3	8	80	90	70 <sup>0</sup> <sub>-0.030</sub>	7	19 <sup>0</sup> <sub>-0.013</sub> *	No tap	No key				13.8	27	15	3.6 (4.6)	
10A□A61 (10A□A6C)												M6 x 10L	22	3.5	6	6					

Note: The models and values in parentheses are for servomotors with holding brakes.

\*: When you need the same shaft diameter as the conventional servomotors, contact your Yaskawa representative.

## Shaft End and Other Options

### ● With Two Flat Seats

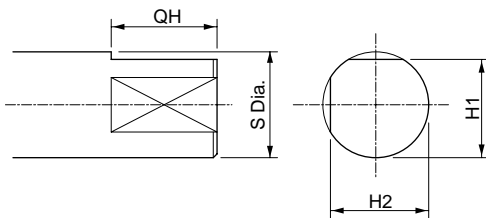

Model SGMAV-	Dimensions of Servomotor with Two Flat Seats			
	QH	S	H1	H2
02A□AB□	14	14 <sup>0</sup> <sub>-0.011</sub>	13	13
04A□AB□				
06A□AB□				
08A□AB□	22	19 <sup>0</sup> <sub>-0.013</sub>	18	18
10A□AB□				

### ● With an Oil Seal

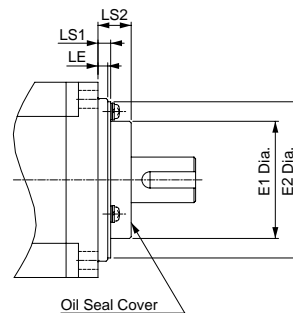

Model SGMAV-	Dimensions of Servomotor with an Oil Seal			
	E1	E2	LS1	LS2
02A, 04A, 06A	36	48	4	10
08A, 10A	49	66	6	11

Note: The 7th digit of the model designation is "S" or "E."  
The key dimensions are the same as those in the table above.

## Selecting Cables

### ● Cables Connections

● Standard Wiring (Max. encoder cable length: 20 m)

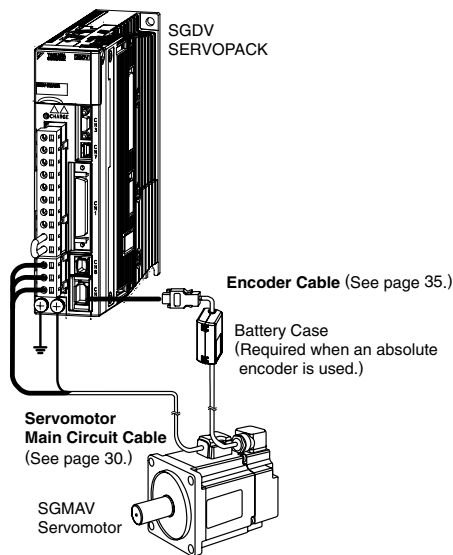

● Encoder Cable Extension from 30 to 50 m

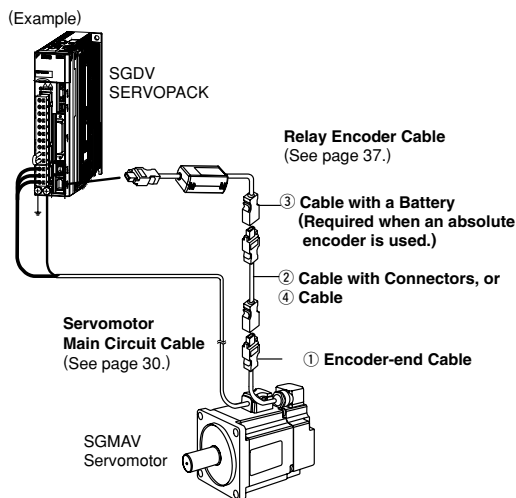

### CAUTION

- Separate the servomotor main circuit cable wiring from the I/O signal cable and encoder cable at least 30 cm, and do not bundle or run them in the same duct.
- When the cable length exceeds 20 m, be sure to use a relay encoder cable.
- When the main circuit cable length exceeds 20 m, note that the intermittent duty zone of the Torque-Motor Speed Characteristics will shrink as the line-to-line voltage drops.

### ● Servomotor Main Circuit Cable



Name	Servomotor Rated Output	Length	Order No.			Specifications	Details
			Standard Type	Flexible Type*	Premium Type*		
For Servomotor without Holding Brakes	50 to 150 W	3 m	JZSP-CSM01-03-E	JZSP-CSM21-03-E	YAI-CSM21-03-P-E		(1)
		5 m	JZSP-CSM01-05-E	JZSP-CSM21-05-E	YAI-CSM21-05-P-E		
		10 m	JZSP-CSM01-10-E	JZSP-CSM21-10-E	YAI-CSM21-10-P-E		
		15 m	JZSP-CSM01-15-E	JZSP-CSM21-15-E	YAI-CSM21-15P-E		
		20 m	JZSP-CSM01-20-E	JZSP-CSM21-20-E	YAI-CSM21-20-P-E		
		30 m	JZSP-CSM01-30-E	JZSP-CSM21-30-E	YAI-CSM21-30-P-E		
		40 m	JZSP-CSM01-40-E	JZSP-CSM21-40-E	YAI-CSM21-40-P-E		
	50 m	JZSP-CSM01-50-E	JZSP-CSM21-50-E	YAI-CSM21-50-P-E			
	200 to 550 W	3 m	JZSP-CSM02-03-E	JZSP-CSM22-03-E	YAI-CSM22-03-P-E		
		5 m	JZSP-CSM02-05-E	JZSP-CSM22-05-E	YAI-CSM22-05-P-E		
		10 m	JZSP-CSM02-10-E	JZSP-CSM22-10-E	YAI-CSM22-10-P-E		
		15 m	JZSP-CSM02-15-E	JZSP-CSM22-15-E	YAI-CSM22-15P-E		
		20 m	JZSP-CSM02-20-E	JZSP-CSM22-20-E	YAI-CSM22-20-P-E		
		30 m	JZSP-CSM02-30-E	JZSP-CSM22-30-E	YAI-CSM22-30-P-E		
		40 m	JZSP-CSM02-40-E	JZSP-CSM22-40-E	YAI-CSM22-40-P-E		
	50 m	JZSP-CSM02-50-E	JZSP-CSM22-50-E	YAI-CSM22-50-P-E			
	750 W, 1.0 kW	3 m	JZSP-CSM03-03-E	JZSP-CSM23-03-E	YAI-CSM23-03-P-E		
		5 m	JZSP-CSM03-05-E	JZSP-CSM23-05-E	YAI-CSM23-05-P-E		
		10 m	JZSP-CSM03-10-E	JZSP-CSM23-10-E	YAI-CSM23-10-P-E		
		15 m	JZSP-CSM03-15-E	JZSP-CSM23-15-E	YAI-CSM23-15P-E		
		20 m	JZSP-CSM03-20-E	JZSP-CSM23-20-E	YAI-CSM23-20-P-E		
		30 m	JZSP-CSM03-30-E	JZSP-CSM23-30-E	YAI-CSM23-30-P-E		
		40 m	JZSP-CSM03-40-E	JZSP-CSM23-40-E	YAI-CSM23-40-P-E		
	50 m	JZSP-CSM03-50-E	JZSP-CSM23-50-E	YAI-CSM23-50-P-E			

\*: Use flexible cables for movable sections such as robot arms.

(Cont'd)

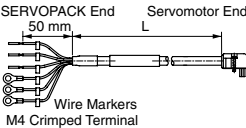

## Selecting Cables

Name	Servomotor Rated Output	Length	Order No.			Specifications	Details
			Standard Type	Flexible Type*	Premium Type*		
For Servomotor with Holding Brakes	50 to 150 W	3 m	JZSP-CSM11-03-E	JZSP-CSM31-03-E	YAI-CSM31-03-P-E		(2)
		5 m	JZSP-CSM11-05-E	JZSP-CSM31-05-E	YAI-CSM31-05-P-E		
		10 m	JZSP-CSM11-10-E	JZSP-CSM31-10-E	YAI-CSM31-10-P-E		
		15 m	JZSP-CSM11-15-E	JZSP-CSM31-15-E	YAI-CSM31-15-P-E		
		20 m	JZSP-CSM11-20-E	JZSP-CSM31-20-E	YAI-CSM31-20-P-E		
		30 m	JZSP-CSM11-30-E	JZSP-CSM31-30-E	YAI-CSM31-30-P-E		
		40 m	JZSP-CSM11-40-E	JZSP-CSM31-40-E	YAI-CSM31-40-P-E		
	200 to 550 W	3 m	JZSP-CSM12-03-E	JZSP-CSM32-03-E	YAI-CSM32-03-P-E		
		5 m	JZSP-CSM12-05-E	JZSP-CSM32-05-E	YAI-CSM32-05-P-E		
		10 m	JZSP-CSM12-10-E	JZSP-CSM32-10-E	YAI-CSM32-10-P-E		
		15 m	JZSP-CSM12-15-E	JZSP-CSM32-15-E	YAI-CSM32-15-P-E		
		20 m	JZSP-CSM12-20-E	JZSP-CSM32-20-E	YAI-CSM32-20-P-E		
		30 m	JZSP-CSM12-30-E	JZSP-CSM32-30-E	YAI-CSM32-30-P-E		
		40 m	JZSP-CSM12-40-E	JZSP-CSM32-40-E	YAI-CSM32-40-P-E		
	750 W, 1.0 kW	3 m	JZSP-CSM13-03-E	JZSP-CSM33-03-E	YAI-CSM33-03-P-E		
		5 m	JZSP-CSM13-05-E	JZSP-CSM33-05-E	YAI-CSM33-05-P-E		
		10 m	JZSP-CSM13-10-E	JZSP-CSM33-10-E	YAI-CSM33-10-P-E		
		15 m	JZSP-CSM13-15-E	JZSP-CSM33-15-E	YAI-CSM33-15-P-E		
		20 m	JZSP-CSM13-20-E	JZSP-CSM33-20-E	YAI-CSM33-20-P-E		
		30 m	JZSP-CSM13-30-E	JZSP-CSM33-30-E	YAI-CSM33-30-P-E		
		40 m	JZSP-CSM13-40-E	JZSP-CSM33-40-E	YAI-CSM33-40-P-E		
Servomotor-end Connector Kit	50 to 150 W	JZSP-CSM9-1-E			N/A	Crimping Type (A crimp tool is required.) 	(3)
	200 to 550 W	JZSP-CSM9-2-E			N/A		(4)
	750 W, 1.0 kW	JZSP-CSM9-3-E			N/A		(5)
Cables	50 to 550 W	5 m	JZSP-CSM90-05-E	JZSP-CSM80-05-E	N/A		(6)
		10 m	JZSP-CSM90-10-E	JZSP-CSM80-10-E	N/A		
		15 m	JZSP-CSM90-15-E	JZSP-CSM80-15-E	N/A		
		20 m	JZSP-CSM90-20-E	JZSP-CSM80-20-E	N/A		
		30 m	JZSP-CSM90-30-E	JZSP-CSM80-30-E	N/A		
		40 m	JZSP-CSM90-40-E	JZSP-CSM80-40-E	N/A		
		50 m	JZSP-CSM90-50-E	JZSP-CSM80-50-E	N/A		
	750 W, 1.0kW	5 m	JZSP-CSM91-05-E	JZSP-CSM81-05-E	N/A		(7)
		10 m	JZSP-CSM91-10-E	JZSP-CSM81-10-E	N/A		
		15 m	JZSP-CSM91-15-E	JZSP-CSM81-15-E	N/A		
		20 m	JZSP-CSM91-20-E	JZSP-CSM81-20-E	N/A		
		30 m	JZSP-CSM91-30-E	JZSP-CSM81-30-E	N/A		
		40 m	JZSP-CSM91-40-E	JZSP-CSM81-40-E	N/A		
		50 m	JZSP-CSM91-50-E	JZSP-CSM81-50-E	N/A		

\*: Use flexible cables for movable sections such as robot arms.

Selecting Cables

(1) Wiring Specifications for Servomotors without Holding Brakes

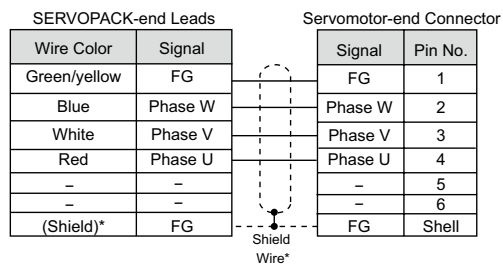

\* Shield wire only on Premium Type Cables, and is accessible if cable jacket is removed.

(2) Wiring Specifications for Servomotor with Holding Brakes

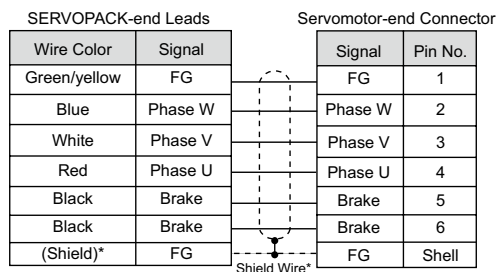

Note: No polarity for connection to a holding brake.  
\*Shield wire only on premium-type cables, and is accessible if cable jacket is removed.

(3) Servomotor-end Connector Kit Specifications: For 50 to 150 W Servomotors

Items	Specifications	External Dimensions mm
Order No.	JZSP-CSM9-1-E (Cables are not included.)	
Applicable Servomotors	SGMAV-A5A, -01A, -C2A	
Manufacturer	J.S.T. Mfg. Co., Ltd.	
Receptacle	J17-06FMH-7KL-1-CF	
Electrical Contact	SJ1F-01GF-P0.8	
Applicable Wire Size	AWG20 to 24	
Outer Diameter of Insulating Sheath	1.11 dia. to 1.53 dia. mm	
Crimp Hand tool	YRS-8841	
Tool Applicator	APLMK SJ1F/M-01-08	
Mounting Screw	M2 Pan-head screw	
Applicable Cable Outer Diameter	7±0.3 dia. mm	

## Selecting Cables

### (4) Servomotor-end Connector Kit Specifications: For 200 to 550 W Servomotors

Items		Specifications	External Dimensions mm
Order No.	JZSP-CSM9-2-E (Cables are not included.)		
Applicable Servomotors	SGMAV-02A, -04A, -06A		
Manufacturer	J.S.T. Mfg. Co., Ltd.		
Receptacle	J27-06FMH-7KL-1-CF		
Electrical Contact	SJ2F-01GF-P1.0		
Applicable Wire Size	AWG20 to 24		
Outer Diameter of Insulating Sheath	1.11 dia. to 1.53 dia. mm		
Crimp Tool	Hand tool	YRS-8861	
	Applicator	APLMK SJ2F/M-01-08	
Mounting Screw	M2 Pan-head screw		
Applicable Cable Outer Diameter	7±0.3 dia. mm		

### (5) Servomotor-end Connector Kit Specifications: For 750 W, 1.0 kW Servomotors

Items		Specifications		External Dimensions mm
Order No.	JZSP-CSM9-3-E (Cables are not included.)			
Applicable Servomotors	SGMAV-08A,-10A			
Manufacturer	J.S.T. Mfg. Co., Ltd.			
Receptacle	J37-06FMH-8KL-1-CF			
Cable Type	Standard			
Electrical Contact	SJ3F-41GF-P1.8 (For power terminals)	SJ3F-01GF-P1.8 (For holding brake terminals)		
Applicable Wire Size	AWG16 to 20	AWG20 to 24		
Outer Diameter of Insulating Sheath	1.53 dia. to 2.5 dia. mm	1.11 dia. to 1.86 dia. mm		
Crimp Tool	Hand tool	YRF-880	YRF-881	
	Applicator	APLMK SF3F/M-41-20	APLMK SF3F/M-01-20	
Mounting Screw	M2.5 Pan-head screw			
Applicable Cable Outer Diameter	8±0.3 dia. mm			

## Selecting Cables

### (6) Cable Specifications: For 50 to 550 W Servomotors

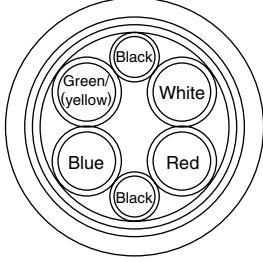
Items	Standard Type	Flexible Type
Order No.*	JZSP-CSM90-□□-E (50 m max.)	JZSP-CSM80-□□-E (50 m max.)
Specifications	UL2517 (Max. operating temperature: 105°C) AWG20×6C For power line: AWG20 (0.52 mm <sup>2</sup> ) Outer diameter of insulating sheath: 1.53 dia. mm For holding brake line: AWG20 (0.52 mm <sup>2</sup> ) Outer diameter of insulating sheath: 1.53 dia. mm	UL2517 (Max. operating temperature: 105°C) AWG22×6C For power line: AWG22 (0.33 mm <sup>2</sup> ) Outer diameter of insulating sheath: 1.37 dia. mm For holding brake line: AWG22 (0.33 mm <sup>2</sup> ) Outer diameter of insulating sheath: 1.37 dia. mm
Finished Dimensions	7±0.3 dia. mm	
Internal Configuration and Lead Color		
Yaskawa Standard Specifications (Standard Length)	Cable length: 5 m, 10 m, 15 m, 20 m, 30 m, 40 m, 50 m	

\*: Specify the cable length in □□ of order no.  
 Example: JZSP-CSM90-05-E (5 m)

### (7) Cable Specifications: For 750 W, 1.0 kW Servomotors

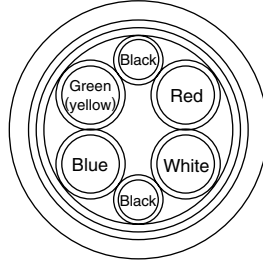
Items	Standard Type	Flexible Type
Order No.*	JZSP-CSM91-□□-E (50 m max.)	JZSP-CSM81-□□-E (50 m max.)
Specifications	UL2517 (Max. operating temperature: 105°C) AWG16×4C, AWG20×2C For power line: AWG16 (1.31 mm <sup>2</sup> ) Outer diameter of insulating sheath: 2.15 dia. mm For holding brake line: AWG20 (0.52 mm <sup>2</sup> ) Outer diameter of insulating sheath: 1.6 dia. mm	UL2517 (Max. operating temperature: 105°C) AWG16×4C, AWG22×2C For power line: AWG16 (1.31 mm <sup>2</sup> ) Outer diameter of insulating sheath: 2.35 dia. mm For holding brake line: AWG22 (0.33 mm <sup>2</sup> ) Outer diameter of insulating sheath: 1.37 dia. mm
Finished Dimensions	8±0.3 dia. mm	
Internal Configuration and Lead Color		
Yaskawa Standard Specifications (Standard Length)	Cable length: 5 m, 10 m, 15 m, 20 m, 30 m, 40 m, 50 m	

\*: Specify the cable length in □□ of order no.  
 Example: JZSP-CSM91-15-E (15 m)

# Selecting Cables

## Encoder Cables (Length: 20 m or less)

Name	Length	Order No.		Specifications	Details
		Standard Type	Flexible Type*		
Cable with Connectors (For Incremental Encoder)	3 m	JZSP-CSP01-03-E	JZSP-CSP21-03-E		(1)
	5 m	JZSP-CSP01-05-E	JZSP-CSP21-05-E		
	10 m	JZSP-CSP01-10-E	JZSP-CSP21-10-E		
	15 m	JZSP-CSP01-15-E	JZSP-CSP21-15-E		
	20 m	JZSP-CSP01-20-E	JZSP-CSP21-20-E		
Cable with Connectors (For Absolute Encoder, with a Battery Case)	3 m	JZSP-CSP05-03-E	JZSP-CSP25-03-E		(2)
	5 m	JZSP-CSP05-05-E	JZSP-CSP25-05-E		
	10 m	JZSP-CSP05-10-E	JZSP-CSP25-10-E		
	15 m	JZSP-CSP05-15-E	JZSP-CSP25-15-E		
	20 m	JZSP-CSP05-20-E	JZSP-CSP25-20-E		
SERVOPACK-end Connector Kit		JZSP-CMP9-1-E		Soldered 	(3)
Encoder-end Connector Kit		JZSP-CSP9-2-E		Crimping Type (A crimp tool is required.) 	
Cables	3 m	JZSP-CMP09-03-E	JZSP-CSP39-03-E		(4)
	5 m	JZSP-CMP09-05-E	JZSP-CSP39-05-E		
	10 m	JZSP-CMP09-10-E	JZSP-CSP39-10-E		
	15 m	JZSP-CMP09-15-E	JZSP-CSP39-15-E		
	20 m	JZSP-CMP09-20-E	JZSP-CSP39-20-E		

\*: Use flexible cables for movable sections such as robot arms.

Note: When the battery from the host controller is used for the absolute encoder, no battery case is required. In this case, use a cable for the incremental encoders.

### (1) Wiring Specifications for Cable with Connectors (For incremental encoder)

#### Standard Type

SERVOPACK End		Encoder (Servomotor) End	
Pin No.	Signal	Pin No.	Wire Color
6	/PS	5	Light blue/white
5	PS	4	Light blue
4	BAT (-)	8	Orange/white
3	BAT (+)	9	Orange
2	PG 0V	3	Black
1	PG 5V	6	Red
Shell	FG	Shell	FG

#### Flexible Type

SERVOPACK End		Encoder (Servomotor) End	
Pin No.	Signal	Pin No.	Wire Color
6	/PS	5	Black/pink
5	PS	4	Red/pink
4	BAT (-)	8	Black/light blue
3	BAT (+)	9	Red/light blue
2	PG 0V	3	Green
1	PG 5V	6	Orange
Shell	FG	Shell	FG

### (2) Wiring Specifications for Cable with Connectors (For absolute encoder, with a battery case)

#### Standard Type

SERVOPACK End		Encoder (Servomotor) End	
Pin No.	Signal	Pin No.	Wire Color
6	/PS	5	Light blue/white
5	PS	4	Light blue
4	BAT (-)	8	Orange/white
3	BAT (+)	9	Orange
2	PG 0V	3	Black
1	PG 5V	6	Red
Shell	FG	Shell	FG

Battery Case	
Pin No.	Signal
2	BAT (-)
1	BAT (+)

#### Flexible Type

SERVOPACK End		Encoder (Servomotor) End	
Pin No.	Signal	Pin No.	Wire Color
6	/PS	5	Black/pink
5	PS	4	Red/pink
4	BAT (-)	8	Black/light blue
3	BAT (+)	9	Red/light blue
2	PG 0V	3	Green
1	PG 5V	6	Orange
Shell	FG	Shell	FG

Battery Case	
Pin No.	Signal
2	BAT (-)
1	BAT (+)

Selecting Cables

(3) SERVOPACK-end/Encoder-end Connector Kit Specifications

Items	SERVOPACK-end Connector Kit	Encoder-end Connector Kit
Order No.	JZSP-CMP9-1-E (Cables are not included.)	JZSP-CSP9-2-E (Cables are not included.)
Manufacturer	Molex Japan Co., Ltd.	Molex Japan Co., Ltd.
Specifications	55100-0670 (soldered)	54346-0070 (crimped)* Mounting screw: M2 pan-head screw (×2) Outer diameter of applicable cable: 6.3 dia. to 7.7 dia. mm Applicable wire size: AWG22 to 26 Outer diameter of insulating sheath: 1.05 dia. to 1.4 dia. mm
External Dimensions mm		

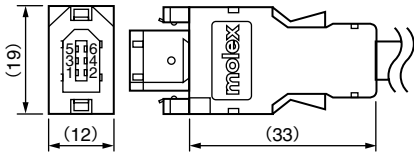
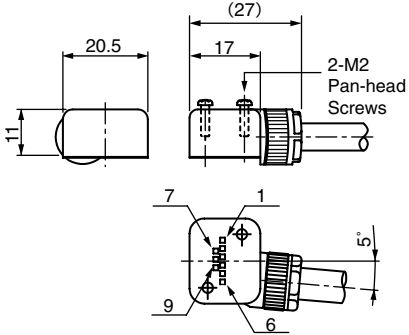
\*: A crimp tool is required.  
The following crimp tools are applicable for the cables provided by Yaskawa. When using other wire sizes, contact the respective manufacturer for crimp tools.  
Applicable crimp tool for Yaskawa's wire size: Hand Tool Model No. 57175-5000  
Applicator Model No. 57175-3000

(4) Cable Specifications

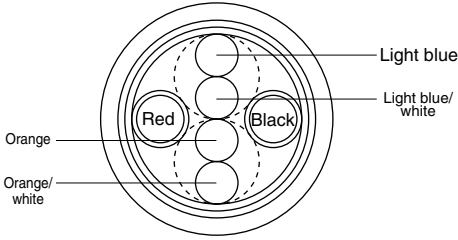
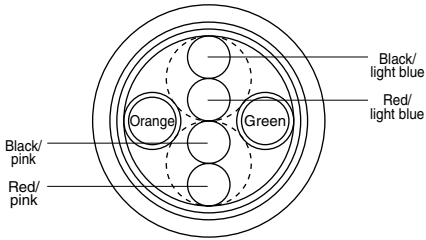

Items	Standard Type	Flexible Type
Order No.*	JZSP-CMP09-□□-E	JZSP-CSP39-□□-E
Cable Length	20 m max.	
Specifications	UL20276 (Max. operating temperature: 80°C) AWG22×2C+AWG24×2P AWG22 (0.33 mm <sup>2</sup> ) Outer diameter of insulating sheath: 1.15 dia. mm AWG24 (0.20 mm <sup>2</sup> ) Outer diameter of insulating sheath: 1.09 dia. mm	UL20276 (Max. operating temperature: 80°C) AWG22×2C+AWG24×2P AWG22 (0.33 mm <sup>2</sup> ) Outer diameter of insulating sheath: 1.35 dia. mm AWG24 (0.20 mm <sup>2</sup> ) Outer diameter of insulating sheath: 1.21 dia. mm
Finished Dimensions	6.5 dia. mm	6.8 dia. mm
Internal Configuration and Lead Color		
Yaskawa Standards Specifications (Standard Length)	Cable length: 5 m, 10 m, 15 m, 20 m	

\*: Specify the cable length in □□ of order no.  
Example: JZSP-CSM09-05-E (5 m)

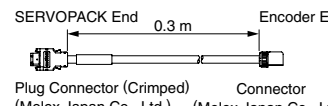
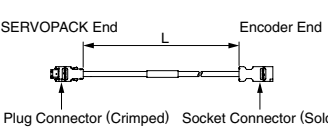
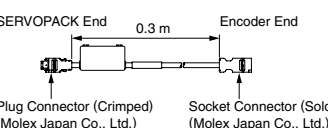

## Selecting Cables

### ● Relay Encoder Cables (For extending from 30 to 50 m)

Name	Length	Order No. Standard Type	Specifications	Details
① Encoder-end Cables (For incremental and absolute encoder)	0.3 m	JZSP-CSP11-E	 <p>SERVOPACK End 0.3 m Encoder End</p> <p>Plug Connector (Crimped) Connector (Molex Japan Co., Ltd.) (Molex Japan Co., Ltd.)</p>	(1)
② Cable with Connectors (For incremental and absolute encoder)	30 m	JZSP-UCMP00-30-E	 <p>SERVOPACK End L Encoder End</p> <p>Plug Connector (Crimped) Socket Connector (Soldered) (Molex Japan Co., Ltd.) (Molex Japan Co., Ltd.)</p>	(2)
	40 m	JZSP-UCMP00-40-E		
	50 m	JZSP-UCMP00-50-E		
③ Cable with a Battery Case (Required when an absolute encoder is used.)	0.3 m	JZSP-CSP12-E*	 <p>SERVOPACK End 0.3 m Encoder End</p> <p>Plug Connector (Crimped) Socket Connector (Soldered) (Molex Japan Co., Ltd.) (Molex Japan Co., Ltd.)</p>	(3)
④ Cables	30 m	JZSP-CMP19-30-E		(4)
	40 m	JZSP-CMP19-40-E		
	50 m	JZSP-CMP19-50-E		

\* When using an incremental encoder or using an absolute encoder with a battery connected to the host controller, no battery case is required.

#### (1) Wiring Specifications for Encoder-end Cable

SERVOPACK End		Encoder (Servomotor) End	
Pin No.	Signal	Pin No.	Wire Color
6	/PS	5	Light blue/white
5	PS	4	Light blue
4	BAT (-)	8	Orange/white
3	BAT (+)	9	Orange
2	PG 0V	3	Black
1	PG 5V	6	Red
Shell	FG	Shell	FG

Shield Wire

#### (2) Wiring Specifications for Cable with Connectors

SERVOPACK End		Encoder (Servomotor) End	
Pin No.	Signal	Pin No.	Wire Color
6	/PS	6	Light blue/white
5	PS	5	Light blue
4	BAT (-)	4	Orange/white
3	BAT (+)	3	Orange
2	PG 0V	2	Black
1	PG 5V	1	Red
Shell	FG	Shell	FG

Shield Wire

Selecting Cables

(3) Wiring Specifications for Cable with a Battery Case

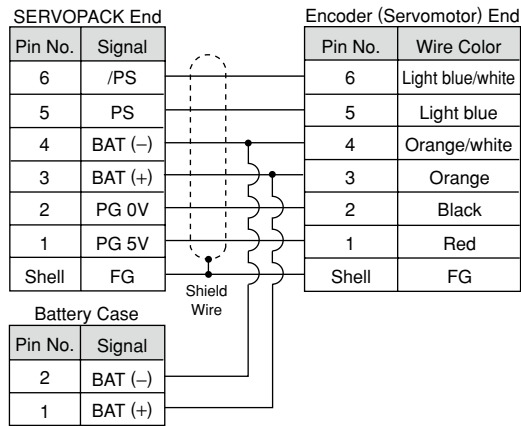

(4) Cable Specifications

Item	Standard Type
Order No.*	JZSP-CMP19-□□-E
Cable Length	50 m max.
Specifications	UL20276 (Max. operating temperature: 80°C) AWG16×2C+AWG26×2P AWG16 (1.31 mm <sup>2</sup> ) Outer diameter of insulating sheath: 2.0 dia. mm AWG26 (0.13 mm <sup>2</sup> ) Outer diameter of insulating sheath: 0.91 dia. mm
Finished Dimensions	6.8 dia. mm
Internal Configuration and Lead Colors	
Yaskawa Standard Specifications (Standard Length)	Cable length: 30 m, 40 m, 50 m

\*: Specify the cable length in □□ of order no.  
Example: JZSP-CMP19-30-E (30 m)

# Rotary Servomotors

# SGMGV



## Model Designations

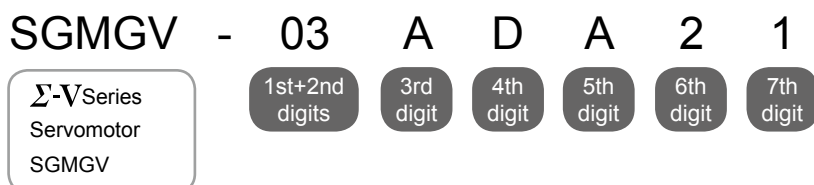

### 1st+2nd digits Rated Output

Code	Specifications
03	300 W
05	450 W
09	850 W
13	1.3 kW
20	1.8 kW
30	2.9 kW
44	4.4 kW
55	5.5 kW
75	7.5 kW
1A	11 kW
1E	15 kW

### 3rd digit Power Supply Voltage

Code	Specifications
A	200 VAC
D	400 VAC

### 4th digit Serial Encoder

Code	Specifications
3	20-bit absolute
D	20-bit incremental

### 5th digit Design Revision Order

Code	Specifications
A	Standard

### 6th digit Shaft End

Code	Specifications
2	Straight without key
6	Straight with key and tap

### 7th digit Options

Code	Specifications
1	Without options
B	With holding brake (90 VDC)
C	With holding brake (24 VDC)
D	With oil seal and holding brake (90 VDC)
E	With oil seal and holding brake (24 VDC)
S	With oil seal

Limited Stock Items

Non-Stock Items

## Features

- High-speed driving of feed shafts for various machines
- Wide selection: 300 W to 15 kW capacity, holding brake option
- Mounted serial encoder: 20 bits, high resolution
- Protective structure: IP67

## Application Examples

- Machine tools
- Transfer machines
- Material handling machines
- Food processing equipment

Configurations of connectors for the main circuit vary depending on servomotor capacity.



### SGMGV-03/-05

- The connectors are used only for Yaskawa servomotors. Order the connectors specified by Yaskawa.
- Both protective structure IP67 and European Safety Standards compliant connectors are available.



### SGMGV-09 to -1E

- The connectors for these models are round. The connectors specified by Yaskawa are required. Note that the connectors vary depending on the operation environment of servomotors.
- Two types of connectors are available.
  - Standard connectors
  - Protective structure IP67 and European Safety Standards compliant connectors.

## Ratings and Specifications

Time Rating: Continuous

Vibration Class: V15

Insulation Resistance: 500 VDC, 10 MΩ min.

Ambient Temperature: 0 to 40°C

Excitation: Permanent magnet

Mounting: Flange-mounted

Thermal Class: F

Withstand Voltage: 1500 VAC for one minute (200-V Class)

1800 VAC for one minute (400-V Class)

Enclosure: Totally enclosed, self-cooled, IP67

(except for shaft opening)

Ambient Humidity: 20% to 80% (no condensation)

Drive Method: Direct drive

Rotation Direction: Counterclockwise (CCW) with forward run reference when viewed from the load side

### 200 V Class

Servomotor Model: SGMGV-□□□□		03A	05A	09A	13A	20A	30A	44A	55A	75A	11A	1EA
Rated Output* <sup>1</sup>	kW	0.3	0.45	0.85	1.3	1.8	2.9	4.4	5.5	7.5	11	15
Rated Torque* <sup>1</sup>	N·m	1.96	2.86	5.39	8.34	11.5	18.6	28.4	35.0	48.0	70.0	95.4
Instantaneous Peak Torque* <sup>1</sup>	N·m	5.88	8.92	13.8	23.3	28.7	45.1	71.1	87.6	119	175	224
Rated Current* <sup>1</sup>	A <sub>rms</sub>	2.8	3.8	6.9	10.7	16.7	23.8	32.8	42.1	54.7	58.6	78
Instantaneous Max. Current* <sup>1</sup>	A <sub>rms</sub>	8	11	17	28	42	56	84	110	130	140	170
Rated Speed* <sup>1</sup>	min <sup>-1</sup>	1500										
Max. Speed* <sup>1</sup>	min <sup>-1</sup>	3000									2000	
Torque Constant	N·m/A <sub>rms</sub>	0.776	0.854	0.859	0.891	0.748	0.848	0.934	0.871	0.957	1.32	1.37
Rotor Moment of Inertia	×10 <sup>-4</sup> kg·m <sup>2</sup>	2.48 (2.73)	3.33 (3.58)	13.9 (16)	19.9 (22)	26 (28.1)	46 (54.5)	67.5 (76.0)	89.0 (97.5)	125 (134)	242 (261)	303 (341)
Rated Power Rate* <sup>1</sup>	kW/s	15.5 (14.1)	24.6 (22.8)	20.9 (18.2)	35.0 (31.6)	50.9 (47.1)	75.2 (63.5)	119 (106)	138 (126)	184 (172)	202 (188)	300 (283)
Rated Angular Acceleration* <sup>1</sup>	rad/s <sup>2</sup>	7900 (7180)	8590 (7990)	3880 (3370)	4190 (3790)	4420 (4090)	4040 (3410)	4210 (3740)	3930 (3590)	3840 (3580)	2890 (2680)	3150 (2960)
Applicable SERVOPACK	SGDV-□□□□	3R8A	3R8A	7R6A	120A	180A	330A 200A <sup>2</sup>	330A	470A	550A	590A	780A

\*1: These items and torque-motor speed characteristics quoted in combination with a SERVOPACK are at an armature winding temperature of 20°C.

\*2: Some restrictions apply when using an SGDV-200A SERVOPACK in combination with an SGMGV-30A servomotor.

Notes: 1 The values in parentheses are for servomotors with holding brakes.

2 The above specifications show the values under the cooling condition when the following heat sinks are mounted on the servomotors.

SGMGV-03A/05A: 250 mm × 250 mm × 6 mm (aluminum)

SGMGV-09A/13A/20A: 400 mm × 400 mm × 20 mm (iron)

SGMGV-30A/44A/55A/75A: 550 mm × 550 mm × 30 mm (iron)

SGMGV-11A/1EA: 650 mm × 650 mm × 35 mm (iron)

### 400 V Class

Servomotor Model: SGMGV-□□□□		03D	05D	09D	13D	20D	30D	44D	55D	75D	11D	1ED
Rated Output*	kW	0.3	0.45	0.85	1.3	1.8	2.9	4.4	5.5	7.5	11	15
Rated Torque*	N·m	1.96	2.86	5.39	8.34	11.5	18.6	28.4	35.0	48.0	70.0	95.4
Instantaneous Peak Torque*	N·m	5.88	8.92	13.8	23.3	28.7	45.1	71.1	87.6	119	175	224
Rated Current*	A <sub>rms</sub>	1.4	1.9	3.5	5.4	8.4	11.9	16.5	20.8	25.7	28.1	37.2
Instantaneous Max. Current*	A <sub>rms</sub>	4	5.5	8.5	14	20	28	40.5	52	65	70	85
Rated Speed*	min <sup>-1</sup>	1500										
Max. Speed*	min <sup>-1</sup>	3000									2000	
Torque Constant	N·m/A <sub>rms</sub>	1.55	1.71	1.72	1.78	1.50	1.70	1.93	1.80	1.92	2.64	2.74
Rotor Moment of Inertia	×10 <sup>-4</sup> kg·m <sup>2</sup>	2.48 (2.73)	3.33 (3.58)	13.9 (16)	19.9 (22)	26 (28.1)	46 (54.5)	67.5 (76.0)	89.0 (97.5)	125 (134)	242 (261)	303 (341)
Rated Power Rate*	kW/s	15.5 (14.1)	24.6 (22.8)	20.9 (18.2)	35.0 (31.6)	50.9 (47.1)	75.2 (63.5)	119 (106)	138 (126)	184 (172)	202 (188)	300 (283)
Rated Angular Acceleration*	rad/s <sup>2</sup>	7900 (7180)	8590 (7990)	3880 (3370)	4190 (3790)	4420 (4090)	4040 (3410)	4210 (3740)	3930 (3590)	3840 (3580)	2890 (2680)	3150 (2960)
Applicable SERVOPACK	SGDV-□□□□	1R9D	1R9D	3R5D	5R4D	8R4D	120D	170D	210D	260D	280D	370D

\*: These items and torque-motor speed characteristics quoted in combination with a SERVOPACK are at an armature winding temperature of 20°C.

Notes: 1 The values in parentheses are for servomotors with holding brakes.

2 The above specifications show the values under the cooling condition when the following heat sinks are mounted on the servomotors.

SGMGV-03D/05D: 250 mm × 250 mm × 6 mm (aluminum)

SGMGV-09D/13D/20D: 400 mm × 400 mm × 20 mm (iron)

SGMGV-30D/44D/55D/75D: 550 mm × 550 mm × 30 mm (iron)

SGMGV-11D/1ED: 650 mm × 650 mm × 35 mm (iron)

**Ratings and Specifications**

● Torque-Motor Speed Characteristics (200 V/400 V) **A**: Continuous Duty Zone **B**: Intermittent Duty Zone <sup>Note1</sup>

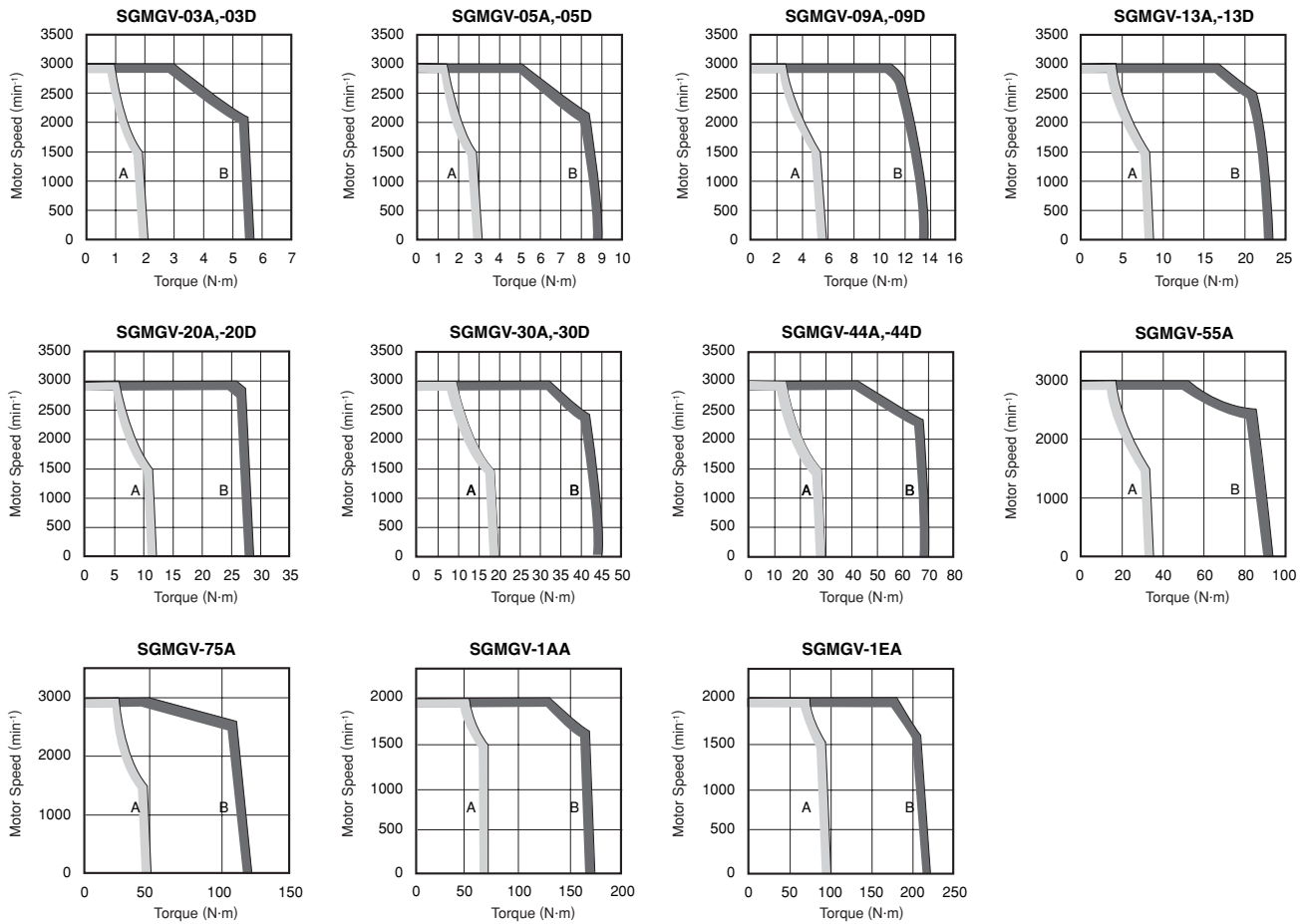

Notes: 1 When the effective torque during intermittent duty is within the rated torque, the servomotor can be used within the intermittent duty zone.  
 2 When the main circuit cable length exceeds 20 m, note that the intermittent duty zone of the Torque-Motor Speed Characteristics will shrink as the line-to-line voltage drops.

● Holding Brake Electrical Specifications

Servomotor Model	Servomotor Rated Output kW	Holding Brake Specifications				
		Holding Torque N-m	Rated Voltage 24 VDC		Rated Voltage 90 VDC	
			Capacity W	Rated Current A (at 20°C)	Capacity W	Rated Current A (at 20°C)
SGMGV-03	0.3	4.5	10	0.42	10	0.11
SGMGV-05	0.45	4.5	10	0.42	10	0.11
SGMGV-09	0.85	12.7	10	0.41	10	0.11
SGMGV-13	1.3	19.6	10	0.41	10	0.11
SGMGV-20	1.8	19.6	10	0.41	10	0.11
SGMGV-30	2.9	43.1	18.5	0.77	18.5	0.21
SGMGV-44	4.4	43.1	18.5	0.77	18.5	0.21
SGMGV-55	5.5	72.6	25	1.05	25	0.28
SGMGV-75	7.5	72.6	25	1.05	25	0.28
SGMGV-1A	11	84.3	32	1.33	32	0.36
SGMGV-1E	15	114.6	35	1.46	35	0.39

Notes: 1 The holding brake is only used to hold the load and cannot be used to stop the servomotor.  
 2 The holding brake open time and holding brake operation time vary depending on which discharge circuit is used. Make sure holding brake open time and holding brake operation time are correct for your servomotor.  
 3 A 24-VDC power supply is provided by customers.

## Ratings and Specifications

### ● Allowable Load Moment of Inertia at the Motor Shaft

The rotor moment of inertia ratio is the value for a servomotor without a gear and a holding brake.

Servomotor Model	Servomotor Rated Output	Allowable Load Moment of Inertia (Rotor Moment of Inertia Ratio)
SGMGV-03 to -1E	0.3 to 1.5 kW	5 times

### ● Load Moment of Inertia

- The larger the load moment of inertia, the worse the movement response of the load.
- The allowable load moment of inertia (JL) depends on motor capacity, as shown above. This value is provided strictly as a guideline and results may vary depending on servomotor drive conditions.
- Use the AC servo drive capacity selection program SigmaJunmaSize+ to check the operation conditions. The program can be downloaded for free from our web site (<http://www.e-mechatronics.com/>).
- An overvoltage alarm (A.400) is likely to occur during deceleration if the load moment of inertia exceeds the allowable load moment of inertia. SERVOPACKs with a built-in regenerative resistor may generate a regenerative overload alarm (A.320). Take one of the following steps if this occurs.
  - Reduce the torque limit.
  - Reduce the deceleration rate.
  - Reduce the maximum speed.
  - Install an external regenerative resistor if the alarm cannot be cleared using the steps above. Refer to Regenerative Resistors on page 386.

### ● Allowable Radial and Thrust Loads

Design the mechanical system so thrust and radial loads applied to the servomotor shaft end during operation fall within the ranges shown in the table.

Servomotor Model	Allowable Radial Load (Fr) N	Allowable Thrust Load (Fs) N	LR mm	Reference Diagram	
SGMGV-	03□□A21	490	98	37	
	05□□A21	490	98	40	
	09□□A21	490	98	58	
	13□□A21	686	343	58	
	20□□A21	980	392	58	
	30□□A21	1470	490	79	
	44□□A21	1470	490	79	
	55□□A21	1764	588	113	
	75□□A21	1764	588	113	
	1A□□A21	1764	588	116	
	1E□□A21	4998	2156	116	



## External Dimensions Units: mm

### ● Without Holding Brakes

(1) 300 W, 450 W

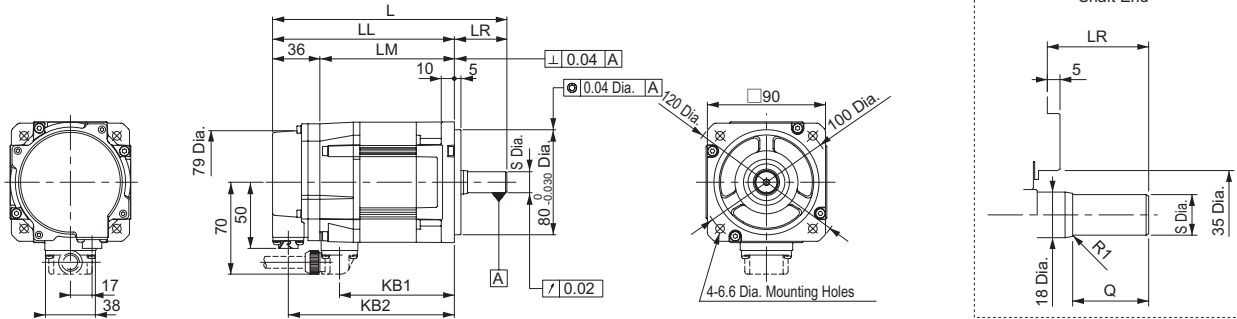

Note: For the specifications of the other shaft ends, refer to page 58.

Model SGMGV-	L	LL	LM	LR	KB1	KB2	Shaft End Dimensions		Approx. Mass kg
							S	Q	
03□□A21	163	126	90	37	75	114	14 <sup>0</sup> <sub>0.011</sub>	25	2.6
05□□A21	179	139	103	40	88	127	16 <sup>0</sup> <sub>0.011</sub>	30	3.2

Note: Models with oil seals are of the same configuration.

#### · Cable Specifications for Encoder-end Connector (20-bit Encoder)

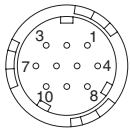

Receptacle: CM10-R10P-D  
 Applicable plug (To be provided by the customer)  
 Plug: CM10-AP10S-□-D (Angle)  
 CM10-SP10S-□-D (Straight)  
 (Boxes (□) indicate a value that varies, depending on cable size.)  
 Manufacturer: DDK Ltd.

#### · Cable Specifications for Servomotor-end Connector

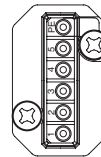

PE	FG (Frame ground)
5	—
4	—
3	Phase U
2	Phase V
1	Phase W

Manufacturer: Japan Aviation Electronics Industry, Ltd.

#### With an Absolute Encoder

1	PS	6	BAT (+)
2	/PS	7	—
3	—	8	—
4	PG 5V	9	PG 0V
5	BAT (-)	10	FG (Frame ground)

#### With an Incremental Encoder

1	PS	6	—
2	/PS	7	—
3	—	8	—
4	PG 5V	9	PG 0V
5	—	10	FG (Frame ground)

# External Dimensions Units: mm

(2) 850 W to 7.5 kW

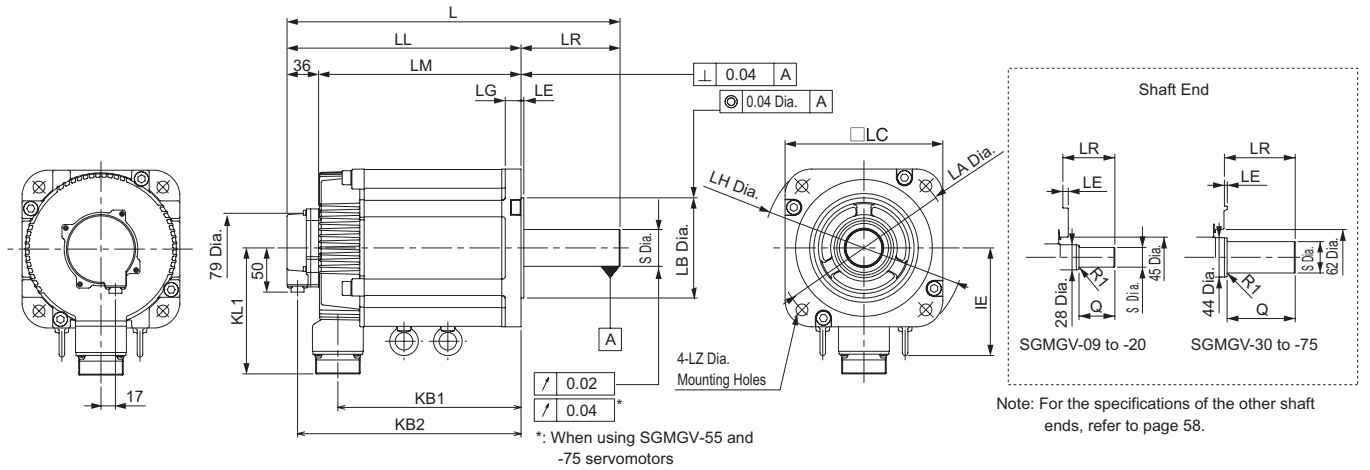

Model SGMGV-	L	LL	LM	LR	KB1	KB2	IE	KL1	Flange Face Dimensions						Shaft End Dimensions		Approx. Mass kg	
									LA	LB	LC	LE	LG	LH	LZ	S		Q
09□□A21	195	137	101	58	83	125	-	104	145	110 <sup>0</sup> <sub>-0.035</sub>	130	6	12	165	9	19 <sup>0</sup> <sub>-0.013</sub>	40	5.5
13□□A21	211	153	117	58	99	141	-	104	145	110 <sup>0</sup> <sub>-0.035</sub>	130	6	12	165	9	22 <sup>0</sup> <sub>-0.013</sub>	40	7.1
20□□A21	229	171	135	58	117	159	-	104	145	110 <sup>0</sup> <sub>-0.035</sub>	130	6	12	165	9	24 <sup>0</sup> <sub>-0.013</sub>	40	8.6
30□□A21	239	160	124	79	108	148	-	134	200	114.3 <sup>0</sup> <sub>-0.025</sub>	180	3.2	18	230	13.5	35 <sup>+0.01</sup> <sub>0</sub>	76	13.5
44□□A21	263	184	148	79	132	172	-	134	200	114.3 <sup>0</sup> <sub>-0.025</sub>	180	3.2	18	230	13.5	35 <sup>+0.01</sup> <sub>0</sub>	76	17.5
55□□A21	334	221	185	113	163	209	123	144	200	114.3 <sup>0</sup> <sub>-0.025</sub>	180	3.2	18	230	13.5	42 <sup>0</sup> <sub>-0.016</sub>	110	21.5
75□□A21	380	267	231	113	209	255	123	144	200	114.3 <sup>0</sup> <sub>-0.025</sub>	180	3.2	18	230	13.5	42 <sup>0</sup> <sub>-0.016</sub>	110	29.5

Note: Models with oil seals are of the same configuration.

· Cable Specifications for Encoder-end Connector (20-bit Encoder)

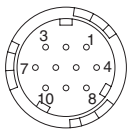

Receptacle: CM10-R10P-D  
 Applicable plug (To be provided by the customer)  
 Plug: CM10-AP10S-□-D (Angle)  
 CM10-SP10S-□-D (Straight)  
 (Boxes (□) indicate a value that varies, depending on cable size.)  
 Manufacturer: DDK Ltd.

· Cable Specifications for Servomotor-end Connector

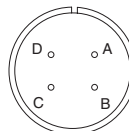

A	Phase U
B	Phase V
C	Phase W
D	FG (Frame ground)

Manufacturer: DDK Ltd.

With an Absolute Encoder

1	PS	6	BAT (+)
2	/PS	7	-
3	-	8	-
4	PG 5V	9	PG 0V
5	BAT (-)	10	FG (Frame ground)

With an Incremental Encoder

1	PS	6	-
2	/PS	7	-
3	-	8	-
4	PG 5V	9	PG 0V
5	-	10	FG (Frame ground)

## External Dimensions Units: mm

(3) 11 kW, 15 kW

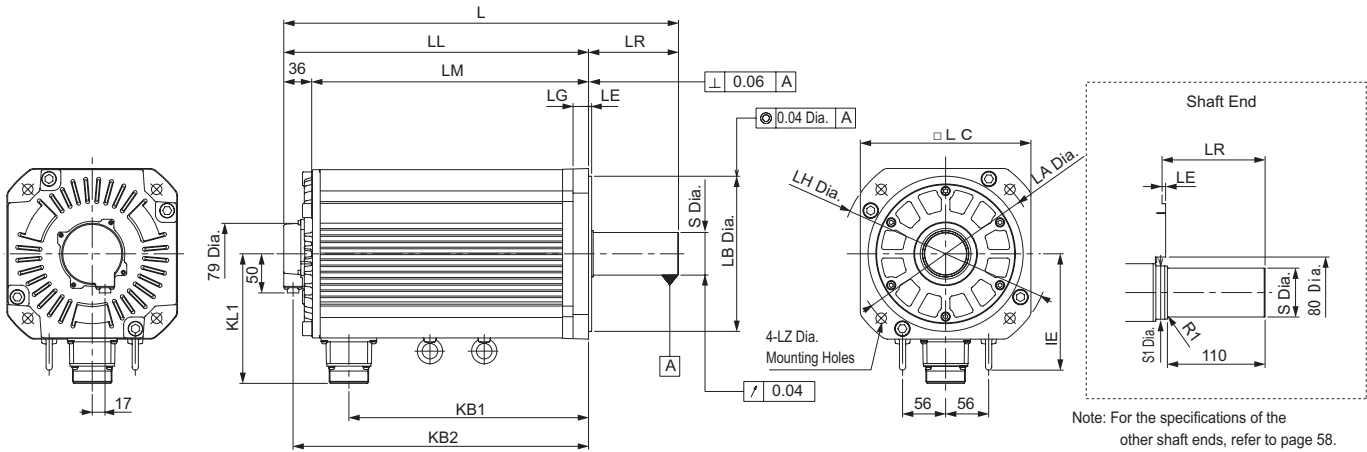

Model SGMGV-	L	LL	LM	LR	KB1	KB2	IE	KL1	Flange Face Dimensions						Shaft End Dimensions		Approx. Mass kg	
									LA	LB	LC	LE	LG	LH	LZ	S		S1
1A□□A21	447	331	295	116	247	319	150	168	235	200 <sup>0</sup> <sub>-0.046</sub>	220	4	20	270	13.5	42 <sup>0</sup> <sub>-0.016</sub>	50	57
1E□□A21	509	393	357	116	309	381	150	168	235	200 <sup>0</sup> <sub>-0.046</sub>	220	4	20	270	13.5	55 <sup>+0.030</sup> <sub>+0.011</sub>	60	67

Note: Models with oil seals are of the same configuration.

· Cable Specifications for Encoder-end Connector (20-bit Encoder)

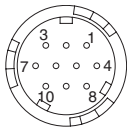

Receptacle: CM10-R10P-D  
 Applicable plug (To be provided by the customer)  
 Plug: CM10-AP10S-□-D (Angle)  
 CM10-SP10S-□-D (Straight)  
 (Boxes (□) indicate a value that varies, depending on cable size.)  
 Manufacturer: DDK Ltd.

· Cable Specifications for Servomotor-end Connector

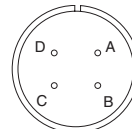

A	Phase U
B	Phase V
C	Phase W
D	FG (Frame ground)

Manufacturer: DDK Ltd.

With an Absolute Encoder

1	PS	6	BAT (+)
2	/PS	7	-
3	-	8	-
4	PG 5V	9	PG 0V
5	BAT (-)	10	FG (Frame ground)

With an Incremental Encoder

1	PS	6	-
2	/PS	7	-
3	-	8	-
4	PG 5V	9	PG 0V
5	-	10	FG (Frame ground)

## External Dimensions Units: mm

### ● With Holding Brakes

(1) 300 W, 450 W

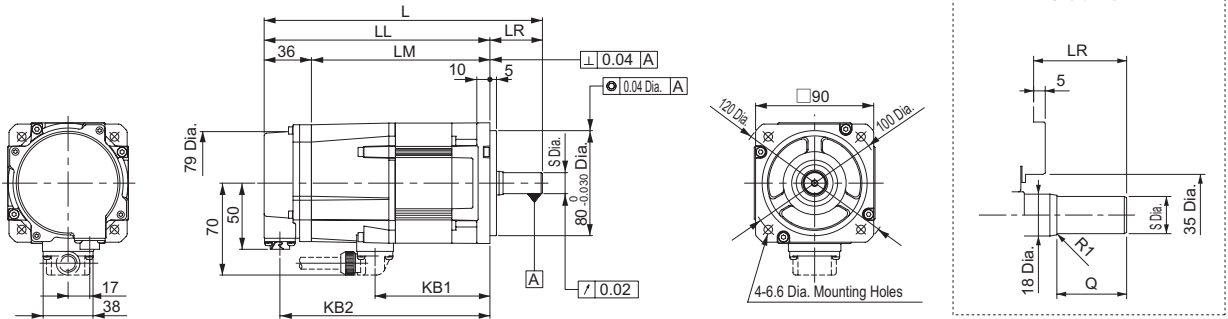

Note: For the specifications of the other shaft ends, refer to page 58.

Model SGMGV-	L	LL	LM	LR	KB1	KB2	Shaft End Dimensions		Approx. Mass kg
							S	Q	
03□□A2□	196	159	123	37	75	147	14 <sup>0</sup> <sub>0.011</sub>	25	3.6
05□□A2□	212	172	136	40	88	160	16 <sup>0</sup> <sub>0.011</sub>	30	4.2

Note: Models with oil seals are of the same configuration.

#### · Cable Specifications for Encoder-end Connector (20-bit Encoder)

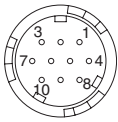

Receptacle: CM10-R10P-D  
 Applicable plug (To be provided by the customer)  
 Plug: CM10-AP10S-□-D (Angle)  
 CM10-SP10S-□-D (Straight)  
 (Boxes (□) indicate a value that varies, depending on cable size.)  
 Manufacturer: DDK Ltd.

#### · Cable Specifications for Servomotor-end Connector

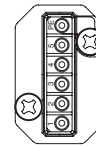

PE	FG (Frame ground)
5	Brake terminal
4	Brake terminal
3	Phase U
2	Phase V
1	Phase W

Manufacturer: Japan Aviation Electronics Industry, Ltd.

#### With an Absolute Encoder

1	PS	6	BAT (+)
2	/PS	7	-
3	-	8	-
4	PG 5V	9	PG 0V
5	BAT (-)	10	FG (Frame ground)

#### With an Incremental Encoder

1	PS	6	-
2	/PS	7	-
3	-	8	-
4	PG 5V	9	PG 0V
5	-	10	FG (Frame ground)

## External Dimensions Units: mm

(2) 850 W to 7.5 kW

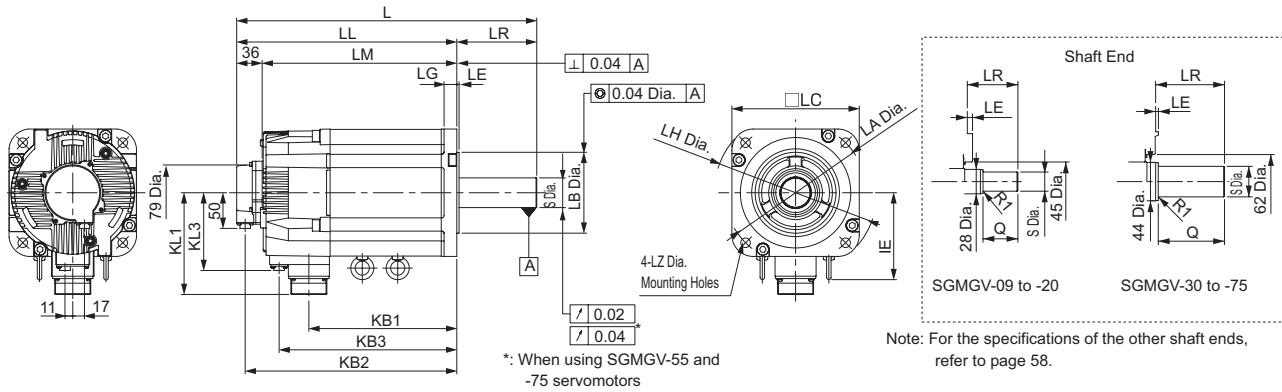

Model SGMGV-	L	LL	LM	LR	KB1	KB2	KB3	IE	KL1	KL3	Flange Face Dimensions						Shaft End Dimensions		Approx. Mass kg	
											LA	LB	LC	LE	LG	LH	LZ	S		Q
09□□A2□	231	173	137	58	83	161	115	-	104	80	145	110 <sup>0</sup> <sub>-0.035</sub>	130	6	12	165	9	19 <sup>0</sup> <sub>-0.013</sub>	40	7.5
13□□A2□	247	189	153	58	99	177	131	-	104	80	145	110 <sup>0</sup> <sub>-0.035</sub>	130	6	12	165	9	22 <sup>0</sup> <sub>-0.013</sub>	40	9.0
20□□A2□	265	207	171	58	117	195	149	-	104	80	145	110 <sup>0</sup> <sub>-0.035</sub>	130	6	12	165	9	24 <sup>0</sup> <sub>-0.013</sub>	40	11.0
30□□A2□	287	208	172	79	108	196	148	-	134	110	200	114.3 <sup>0</sup> <sub>-0.025</sub>	180	3.2	18	230	13.5	35 <sup>+0.01</sup> <sub>0</sub>	76	19.5
44□□A2□	311	232	196	79	132	220	172	-	134	110	200	114.3 <sup>0</sup> <sub>-0.025</sub>	180	3.2	18	230	13.5	35 <sup>+0.01</sup> <sub>0</sub>	76	23.5
55□□A2□	378	265	229	113	163	253	205	123	144	110	200	114.3 <sup>0</sup> <sub>-0.025</sub>	180	3.2	18	230	13.5	42 <sup>0</sup> <sub>-0.016</sub>	110	27.5
75□□A2□	424	311	275	113	209	299	251	123	144	110	200	114.3 <sup>0</sup> <sub>-0.025</sub>	180	3.2	18	230	13.5	42 <sup>0</sup> <sub>-0.016</sub>	110	35

Note: Models with oil seals are of the same configuration.

· Cable Specifications for Encoder-end Connector (20-bit Encoder)

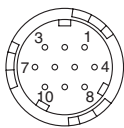

Receptacle: CM10-R10P-D  
 Applicable plug (To be provided by the customer)  
 Plug: CM10-AP10S-□-D (Angle)  
 CM10-SP10S-□-D (Straight)  
 (Boxes □ indicate a value that varies, depending on cable size.)  
 Manufacturer: DDK Ltd.

· Cable Specifications for Servomotor-end Connector

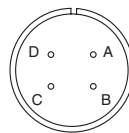

A	Phase U
B	Phase V
C	Phase W
D	FG (Frame ground)

Manufacturer: DDK Ltd.

With an Absolute Encoder

1	PS	6	BAT (+)
2	/PS	7	-
3	-	8	-
4	PG 5V	9	PG 0V
5	BAT (-)	10	FG (Frame ground)

With an Incremental Encoder

1	PS	6	-
2	/PS	7	-
3	-	8	-
4	PG 5V	9	PG 0V
5	-	10	FG (Frame ground)

· Cable Specifications for Brake-end Connector

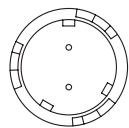

Receptacle: CM10-R2P-D  
 Applicable plug (To be provided by the customer)  
 Plug: CM10-AP2S-□-D (Angle)  
 CM10-SP2S-□-D (Straight)  
 (Boxes □ indicate a value that varies, depending on cable size.)  
 Manufacturer: DDK Ltd.

Brake terminal
Brake terminal

Note: No polarity for connection to the brake terminals

# External Dimensions Units: mm

(3) 11 kW, 15 kW

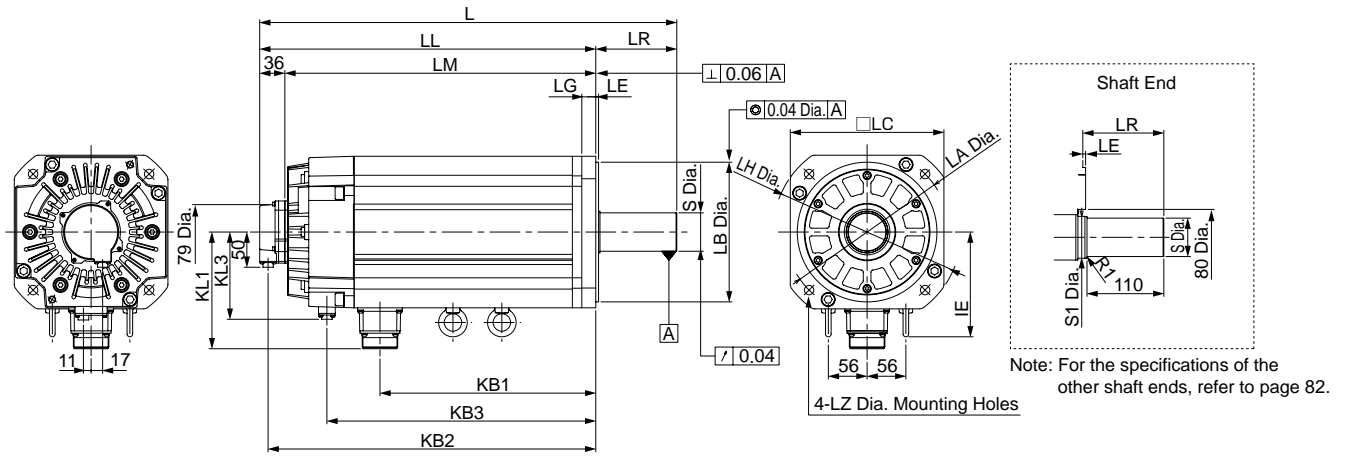

Model SGMGV-	L	LL	LM	LR	KB1	KB2	KB3	IE	KL1	KL3	Flange Face Dimensions						Shaft End Dimensions		Approx. Mass kg	
											LA	LB	LC	LE	LG	LH	LZ	S		S1
1A□□A2□	498	382	346	116	247	370	315	150	168	125	235	200 <sup>0</sup> <sub>-0.046</sub>	220	4	20	270	13.5	42 <sup>0</sup> <sub>-0.016</sub>	50	65
1E□□A2□	598	482	446	116	309	470	385	150	168	125	235	200 <sup>0</sup> <sub>-0.046</sub>	220	4	20	270	13.5	55 <sup>+0.030</sup> <sub>-0.011</sub>	60	85

Note: Models with oil seals are of the same configuration.

### · Cable Specifications for Encoder-end Connector (20-bit Encoder)

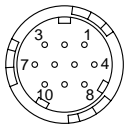

Receptacle: CM10-R10P-D  
 Applicable plug (To be provided by the customer)  
 Plug: CM10-AP10S-□-D (Angle)  
 CM10-SP10S-□-D (Straight)  
 (Boxes (□) indicate a value that varies, depending on cable size.)  
 Manufacturer: DDK Ltd.

### · Cable Specifications for Servomotor-end Connector

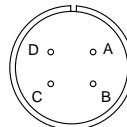

A	Phase U
B	Phase V
C	Phase W
D	FG (Frame ground)

Manufacturer: DDK Ltd.

### With an Absolute Encoder

1	PS	6	BAT (+)
2	/PS	7	-
3	-	8	-
4	PG 5V	9	PG 0V
5	BAT (-)	10	FG (Frame ground)

### With an Incremental Encoder

1	PS	6	-
2	/PS	7	-
3	-	8	-
4	PG 5V	9	PG 0V
5	-	10	FG (Frame ground)

### · Cable Specifications for Brake-end Connector

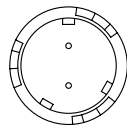

Receptacle: CM10-R2P-D  
 Applicable plug (To be provided by the customer)  
 Plug: CM10-AP2S-□-D (Angle)  
 CM10-SP2S-□-D (Straight)  
 (Boxes (□) indicate a value that varies, depending on cable size.)  
 Manufacturer: DDK Ltd.

Brake terminal
Brake terminal

Note: No polarity for connection to the brake terminals

## External Dimensions Units: mm

● Shaft End

SGMGV -

Code	Specifications	Remarks
2	Straight without key	Standard
6	Straight with key and tap for one location (Key slot is JIS B1301-1996 fastening type)	Optional

Shaft End	Model SGMGV-									
	03	05	09	13	20	30/44	55/75	1A	1E	
Code: 2 (Straight without Key)										
	LR	37	40	58	58	58	79	113	116	116
	Q	25	30	40	40	40	76	110	110	110
	S	14 <sup>0</sup> <sub>-0.011</sub>	16 <sup>0</sup> <sub>-0.011</sub>	19 <sup>0</sup> <sub>-0.013</sub>	22 <sup>0</sup> <sub>-0.013</sub>	24 <sup>0</sup> <sub>-0.013</sub>	35 <sup>+0.01</sup> <sub>0</sub>	42 <sup>0</sup> <sub>-0.016</sub>	42 <sup>0</sup> <sub>-0.016</sub>	55 <sup>+0.030</sup> <sub>+0.011</sub>
Code: 6 (Straight with Key and Tap)										
	LR	37	40	58	58	58	79	113	116	116
	Q	25	30	40	40	40	76	110	110	110
	QK	15	20	25	25	25	60	90	90	90
	S	14 <sup>0</sup> <sub>-0.011</sub>	16 <sup>0</sup> <sub>-0.011</sub>	19 <sup>0</sup> <sub>-0.013</sub>	22 <sup>0</sup> <sub>-0.013</sub>	24 <sup>0</sup> <sub>-0.013</sub>	35 <sup>+0.01</sup> <sub>0</sub>	42 <sup>0</sup> <sub>-0.016</sub>	42 <sup>0</sup> <sub>-0.016</sub>	55 <sup>+0.030</sup> <sub>+0.011</sub>
	W	5	5	5	6	8	10	12	12	16
	T	5	5	5	6	7	8	8	8	10
	U	3	3	3	3.5	4	5	5	5	6
	P	M4 Screw, Depth 10	M5 Screw, Depth 12					M12 Screw, Depth 25	M16 Screw, Depth 32	M20 Screw, Depth 40



## Selecting Main Circuit Cables (SGMGV-03 / -05)

### ● Cables Connections

- Standard Wiring (Max. encoder cable length: 20 m)

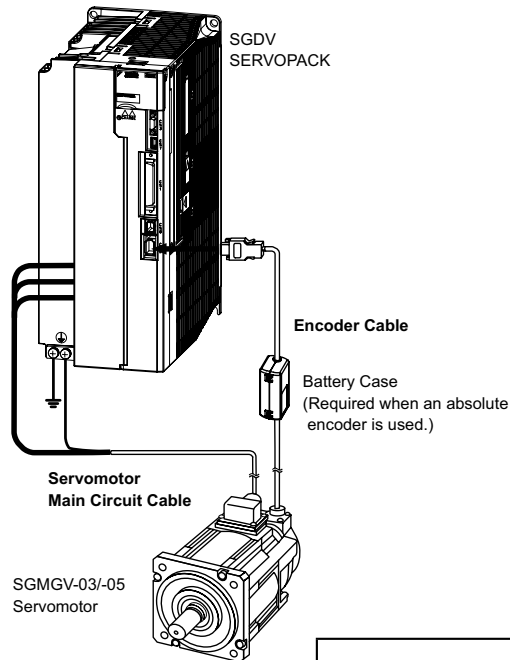

- Encoder Cable Extension from 30 to 50 m

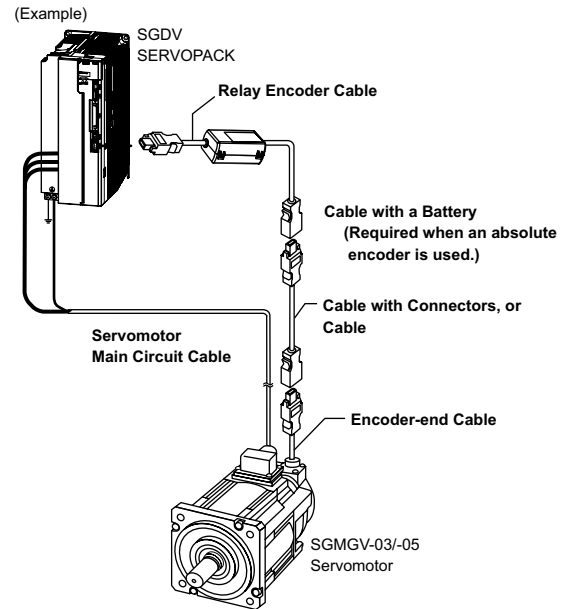

### ⚠ CAUTION

- Separate the servomotor main circuit cable wiring from the I/O signal cable and encoder cable at least 30 cm, and do not bundle or run them in the same duct.
- When the main circuit cable length exceeds 20 m, note that the intermittent duty zone of the Torque-Motor Speed Characteristics will shrink as the line-to-line voltage drops.

### ● Servomotor Main Circuit Cable (Applicable with 200V and 400V Power Supply Voltages)

Servomotor Rated Output	Name	Length	Order No.		Specifications	Details	
			Standard (Flexible) Type*	Premium (Flex + Shield) Type			
0.3 kW 0.45 kW	For Servomotor without Holding Brakes	3 m	JZSP-CVM21-03-E	YEA-CVM21-03(A)-E		(1)	
		5 m	JZSP-CVM21-05-E	YEA-CVM21-05(A)-E			
		10 m	JZSP-CVM21-10-E	YEA-CVM21-10(A)-E			
		15 m	JZSP-CVM21-15-E	YEA-CVM21-15(A)-E			
		20 m	JZSP-CVM21-20-E	YEA-CVM21-20(A)-E			
		30 m	JZSP-CVM21-30-E	-			
		40 m	JZSP-CVM21-40-E	-			
	50 m	JZSP-CVM21-50-E	-				
	For Servomotor with Holding Brakes	3 m	JZSP-CVM41-03-E	YEA-CVM41-03(A)-E		(2)	
		5 m	JZSP-CVM41-05-E	YEA-CVM41-05(A)-E			
		10 m	JZSP-CVM41-10-E	YEA-CVM41-10(A)-E			
		15 m	JZSP-CVM41-15-E	YEA-CVM41-15(A)-E			
		20 m	JZSP-CVM41-20-E	YEA-CVM41-20(A)-E			
		30 m	JZSP-CVM41-30-E	-			
		40 m	JZSP-CVM41-40-E	-			
50 m	JZSP-CVM41-50-E	-					
	Servomotor- end Connector Kit	-	JZSP-CVM9-1-E	-	Crimping Type (A crimp tool is required.)		(3)

\*: These flexible cables are provided as standard equipment.

(Cont'd)

Selecting Main Circuit Cables (SGMGV-03 / -05)

Servomotor Rated Output	Name		Length	Order No.		Specifications	Details
				Standard (Flexible) Type*			
0.3 kW 0.45 kW	Cables	For Servomotor without Holding Brakes (4 wires)	5 m	JZSP-CVM29-05-E		(4)	
			10 m	JZSP-CVM29-10-E			
			15 m	JZSP-CVM29-15-E			
			20 m	JZSP-CVM29-20-E			
			30 m	JZSP-CVM29-30-E			
			40 m	JZSP-CVM29-40-E			
			50 m	JZSP-CVM29-50-E			
		For Servomotor with Holding Brakes (6 wires)	5 m	JZSP-CVM49-05-E		(4)	
			10 m	JZSP-CVM49-10-E			
			15 m	JZSP-CVM49-15-E			
			20 m	JZSP-CVM49-20-E			
			30 m	JZSP-CVM49-30-E			
			40 m	JZSP-CVM49-40-E			
			50 m	JZSP-CVM49-50-E			

(1) Wiring Specifications for Servomotors without Holding Brakes

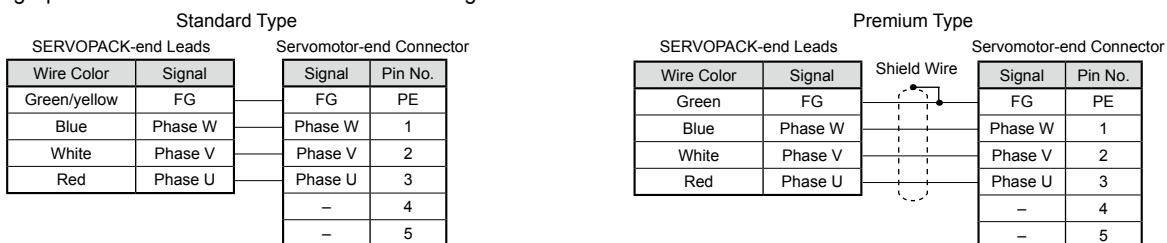

(2) Wiring Specifications for Servomotor with Holding Brakes

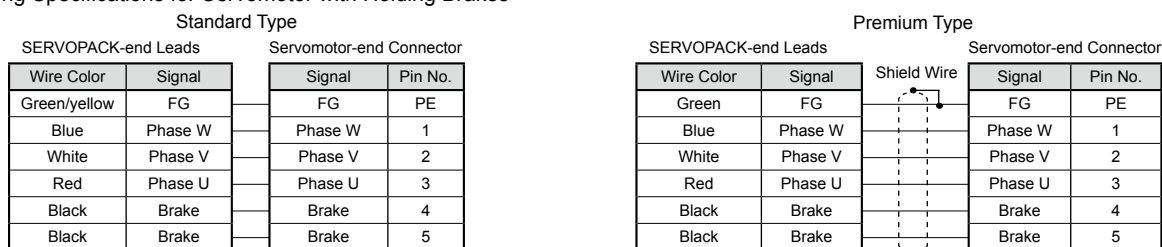

Note: No polarity for connection to a holding brake

Note: No polarity for connection to a holding brake

(3) Servomotor-end Connector Kit Specifications

Items	Specifications	External Dimensions mm
Order No.	JZSP-CVM9-1-E (Cables are not included.)	
Applicable Servomotors	SGMGV-03/-05	
Manufacturer	Japan Aviation Electronics Industry, Ltd.	
Plug	JNYFX06SJ3	
Electrical Contact	ST-TMH-S-C1B	
Applicable Wire Size	AWG18 to 22	
Outer Diameter of Insulating Sheath	1.3 dia. to 1.8 dia.	
Crimp Tool	Hand tool: CT160-3-TMH5B Applicator: 350-TMH5B-2B	
Mounting Screw	M3 Pan head screw	
Applicable Cable Outer Diameter	6.9 dia. to 8.3 dia.	

(4) Cable Specifications

Items	For Servomotor without Holding Brakes (4 wires)	For Servomotor with Holding Brakes (6 wires)
Order No.*	JZSP-CVM29-□□-E	JZSP-CVM49-□□-E
Cable Length	50 m max.	
Specifications	UL2586 (Max. operating temperature: 105°C) AWG20×4C For power line: AWG20 (0.55 mm <sup>2</sup> ) Outer diameter of insulating sheath: 1.77 dia.	UL2586 (Max. operating temperature: 105°C) AWG20×6C For power line: AWG20 (0.55 mm <sup>2</sup> ) Outer diameter of insulating sheath: 1.77 dia. For holding brake line: AWG20 (0.55 mm <sup>2</sup> ) Outer diameter of insulating sheath: 1.77 dia.
Finished Dimensions	7.3±0.3 dia.	7.4±0.3 dia.
Internal Configuration and Lead Color		
Yaskawa Standard Specifications (Standard Length)	Cable length: 5 m, 10 m, 15 m, 20 m, 30 m, 40 m, 50 m	

\*: Specify the cable length in □□ of order no. [ JZSP-CVM29-□□-05-E (5 m) ]

## Selecting Main Circuit Cables (SGMGV-09 to -1E)

### ● Cables Connections

- Standard Wiring (Max. encoder cable length: 20 m)

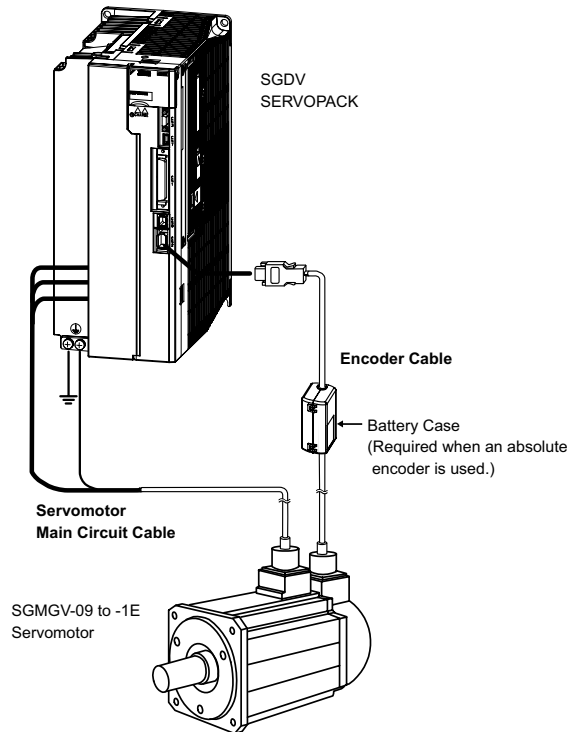

- Encoder Cable Extension from 30 to 50 m

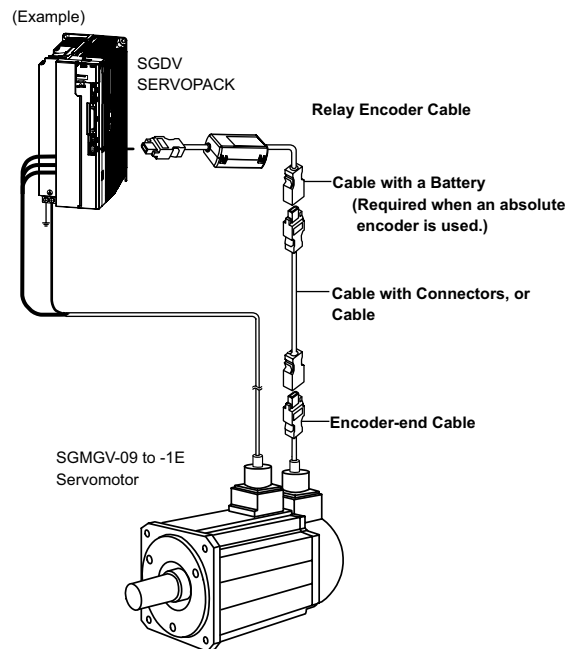

### ⚠ CAUTION

- Separate the servomotor main circuit cable wiring from the I/O signal cable and encoder cable at least 30 cm, and do not bundle or run them in the same duct.
- When the main circuit cable length exceeds 20 m, note that the intermittent duty zone of the Torque-Motor Speed Characteristics will shrink as the line-to-line voltage drops.

Selecting Main Circuit Cables (SGMGV-09 to -1E)

● Servomotor Main Circuit Cables

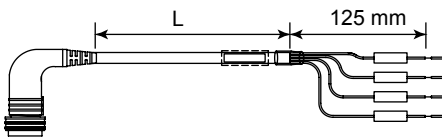
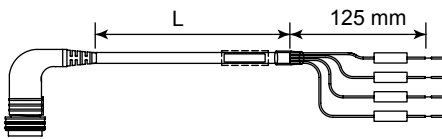
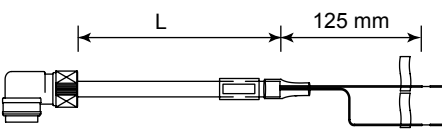
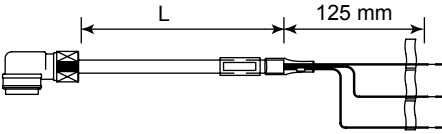
Voltage	Servomotor Rated Output	Name	Length	Order No.		Specifications	Details		
				Value Type	Premium Type *2				
200V	850W, 1.3kW	Servomotor Power Cable *1	3 m	B1EV-03(A)-E	B1EP-03(A)-E		(1)		
			5 m	B1EV-05(A)-E	B1EP-05(A)-E				
			10 m	B1EV-10(A)-E	B1EP-10(A)-E				
			15 m	B1EV-15(A)-E	B1EP-15(A)-E				
			20 m	B1EV-20(A)-E	B1EP-20(A)-E				
	2.0kW		3 m	B2EV-03(A)-E	B2EP-03(A)-E				
			5 m	B2EV-05(A)-E	B2EP-05(A)-E				
			10 m	B2EV-10(A)-E	B2EP-10(A)-E				
			15 m	B2EV-15(A)-E	B2EP-15(A)-E				
			20 m	B2EV-20(A)-E	B2EP-20(A)-E				
	3.0 to 4.4kW		3 m	B4EV-03(A)-E	B4EP-03(A)-E				
			5 m	B4EV-05(A)-E	B4EP-05(A)-E				
			10 m	B4EV-10(A)-E	B4EP-10(A)-E				
			15 m	B4EV-15(A)-E	B4EP-15(A)-E				
			20 m	B4EV-20(A)-E	B4EP-20(A)-E				
	5.5 to 7.5kW		3 m	B6EV-03(A)-E	B6EP-03(A)-E				
			5 m	B6EV-05(A)-E	B6EP-05(A)-E				
			10 m	B6EV-10(A)-E	B6EP-10(A)-E				
			15 m	B6EV-15(A)-E	B6EP-15(A)-E				
			20 m	B6EV-20(A)-E	B6EP-20(A)-E				
11 to 15kW	3 m	B7EV-03(A)-E	B7EP-03(A)-E						
	5 m	B7EV-05(A)-E	B7EP-05(A)-E						
	10 m	B7EV-10(A)-E	B7EP-10(A)-E						
	15 m	B7EV-15(A)-E	B7EP-15(A)-E						
	20 m	B7EV-20(A)-E	B7EP-20(A)-E						
400V	850W, 1.3kW, 2.0kW	3 m	B1EV-03(A)-E	B1EP-03(A)-E		(1)			
		5 m	B1EV-05(A)-E	B1EP-05(A)-E					
		10 m	B1EV-10(A)-E	B1EP-10(A)-E					
		15 m	B1EV-15(A)-E	B1EP-15(A)-E					
		20 m	B1EV-20(A)-E	B1EP-20(A)-E					
	3.0 to 4.4kW	3 m	B3EV-03(A)-E	B3EP-03(A)-E					
		5 m	B3EV-05(A)-E	B3EP-05(A)-E					
		10 m	B3EV-10(A)-E	B3EP-10(A)-E					
		15 m	B3EV-15(A)-E	B3EP-15(A)-E					
		20 m	B3EV-20(A)-E	B3EP-20(A)-E					
	5.5 to 7.5kW	3 m	B5EV-03(A)-E	B5EP-03(A)-E					
		5 m	B5EV-05(A)-E	B5EP-05(A)-E					
		10 m	B5EV-10(A)-E	B5EP-10(A)-E					
		15 m	B5EV-15(A)-E	B5EP-15(A)-E					
		20 m	B5EV-20(A)-E	B5EP-20(A)-E					
	11 to 15kW	3 m	B6EV-03(A)-E	B6EP-03(A)-E					
		5 m	B6EV-05(A)-E	B6EP-05(A)-E					
		10 m	B6EV-10(A)-E	B6EP-10(A)-E					
		15 m	B6EV-15(A)-E	B6EP-15(A)-E					
		20 m	B6EV-20(A)-E	B6EP-20(A)-E					
200V and 400V	850W to 15kW	Holding Brake Cable	3 m	BBEV-03(A)-E	-		(2)		
			5 m	BBEV-05(A)-E	-				
			10 m	BBEV-10(A)-E	-				
			15 m	BBEV-15(A)-E	-				
			20 m	BBEV-20(A)-E	-				
	850W to 15kW		3 m	-	BBEP-03(A)-E				(3)
			5 m	-	BBEP-05(A)-E				
			10 m	-	BBEP-10(A)-E				
			15 m	-	BBEP-15(A)-E				
			20 m	-	BBEP-20(A)-E				

\*1 Servomotors with holding brakes require a holding brake cable in addition to a power cable.

\*2 Premium cables have a braided shield and are intended for use in applications that require CE. B1EP through B5EP have a continuous flex and are intended for use in movable sections such as robot arms.

## Selecting Main Circuit Cables (SGMGV-09 to -1E)

### (1) Wiring Specifications for Servomotors with and without Holding Brakes\*

#### ● Value Type

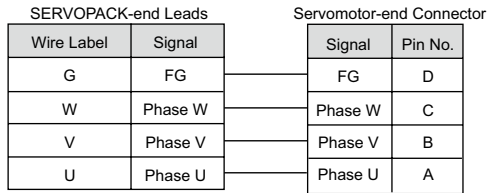

\*For servomotors with holding brakes, the holding brake cable must also be wired.

#### ● Premium Type

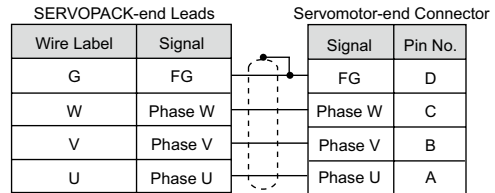

\*For servomotors with holding brakes, the holding brake cable must also be wired.

### (2) Wiring Specifications for the Value Type Brake Cable

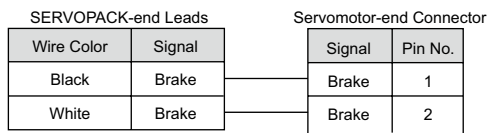

Note: No polarity for connection to a holding brake.

### (3) Wiring Specifications for the Premium Type Brake Cable

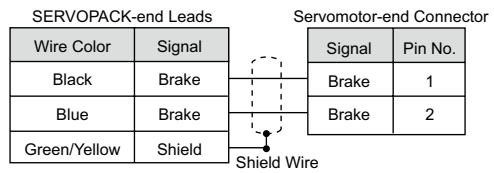

Note: No polarity for connection to a holding brake.

## ● Customer Cable Assembly

- Customers may assemble the servomotor's main circuit cables and attach connectors to connect the SERVOPACKs and the SGMGV servomotors.
- The connectors specified by Yaskawa are required. Note that the connectors vary depending on the operation environment of servomotors.
- Two types of connectors are available.
  - Standard connectors
  - Protective structure IP67 and European Safety Standards compliant connectors
- Yaskawa does not specify which cables to use. Use appropriate cables for the connectors.

Selecting Main Circuit Cables (SGMGV-09 to -1E)

● Standard Connectors

● Connector Configuration

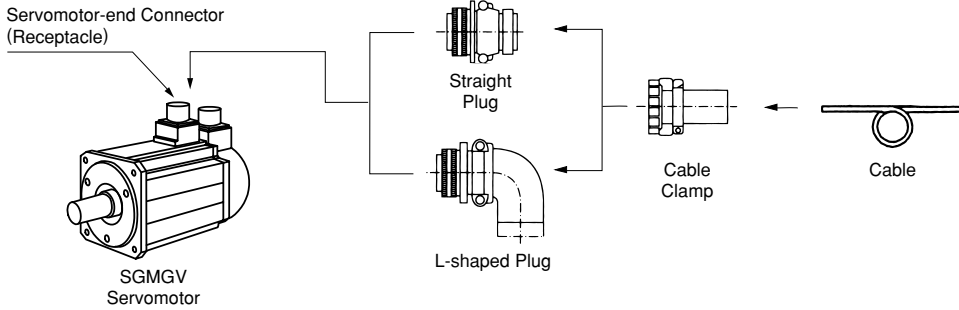

(1) Without Holding Brakes

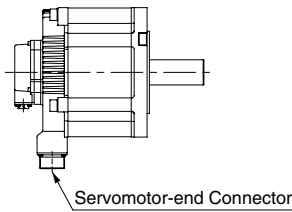

Servomotor-end Connector  
For 0.85 to 15 kW

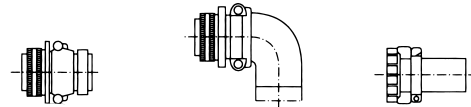

Capacity kW	Servomotor-end Connector (Receptacle)	Cable-end Connector (Not provided by Yaskawa)		
		Straight Plug	L-shaped Plug	Cable Clamp
0.85 1.3 1.8	MS3102A18-10P	MS3106B18-10S	MS3108B18-10S	MS3057-10A
2.9 4.4	MS3102A22-22P	MS3106B22-22S	MS3108B22-22S	MS3057-12A
5.5 to 15	MS3102A32-17P	MS3106B32-17S	MS3108B32-17S	MS3057-20A

Note: Servomotor-end connectors (receptacles) are RoHS-compliant. Contact the respective connector manufacturers for RoHS-compliant cable-end connectors (not provided by Yaskawa).

(2) With Holding Brakes

0.85 to 15 kW servomotors require servomotor-end connector and brake power supply connector. The servomotor-end connector is the same as is used for servomotors without holding brakes.

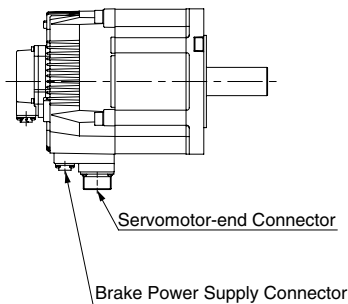

Brake Power Supply Connector  
0.85 to 15 kW

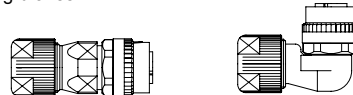

Capacity kW	Servomotor-end Connector (Receptacle)	Cable-end Connector (Not provided by Yaskawa)		
		Straight Plug	L-shaped Plug	Manufacturer
0.85 to 15	CM10-R2P-D	CM10-SP2S-S-D Applicable Cable: 4.0 dia. to 6.0 dia.	CM10-AP2S-S-D Applicable Cable: 4.0 dia. to 6.0 dia.	DDK Ltd.
		CM10-SP2S-M-D Applicable Cable: 6.0 dia. to 9.0 dia.	CM10-AP2S-M-D Applicable Cable: 6.0 dia. to 9.0 dia.	
		CM10-SP2S-L-D Applicable Cable: 9.0 dia. to 11.6 dia.	CM10-AP2S-L-D Applicable Cable: 9.0 dia. to 11.6 dia.	

To order a brake power supply connector kit (0.85 to 15 kW) with the order no. below, contact your Yaskawa representative.

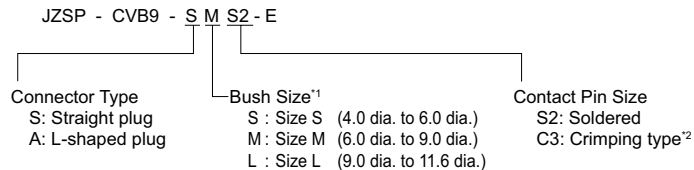

\*1: A size-M connector kit is available as a standard equipment.  
\*2: A crimp tool (model: 357J-50448T) by DDK Ltd. is required.

## Selecting Main Circuit Cables (SGMGV-09 to -1E) Units: mm

### • Cable-end Connectors

#### (1) MS3106B□□-□□S :

##### Straight Plug

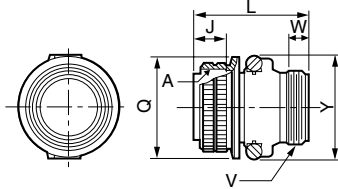

Shell Size	Joint Screw A	Length of Joint Portion J±0.12	Overall Length L max.	Outer Diameter of Joint Nut Q <sup>+0</sup> <sub>-0.38</sub>	Cable Clamp Set Screw V	Effective Screw Length W min.	Maximum Width Y max.
18	1-1/8-18UNEF	18.26	52.37	34.13	1-20UNEF	9.53	42
22	1-3/8-18UNEF	18.26	55.57	40.48	1-3/16-18UNEF	9.53	50
32	2-18UNS	18.26	61.92	56.33	1-3/4-18UNS	11.13	66

#### (2) MS3108B□□-□□S :

##### L-shaped Plug

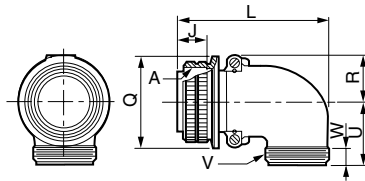

Shell Size	Joint Screw A	Length of Joint Portion J±0.12	Overall Length L max.	Outer Diameter of Joint Nut Q <sup>+0</sup> <sub>-0.38</sub>	R ±0.5	U ±0.5	Cable Clamp Set Screw V	Effective Screw Length W min.
18	1-1/8-18UNEF	18.26	68.27	34.13	20.5	30.2	1-20UNEF	9.53
22	1-3/8-18UNEF	18.26	76.98	40.48	24.1	33.3	1-3/16-18UNEF	9.53
32	2-18UNS	18.26	95.25	56.33	32.8	44.4	1-3/4-18UNS	11.13

#### (3) MS3057-□□A : Cable Clamp with Rubber Bushing

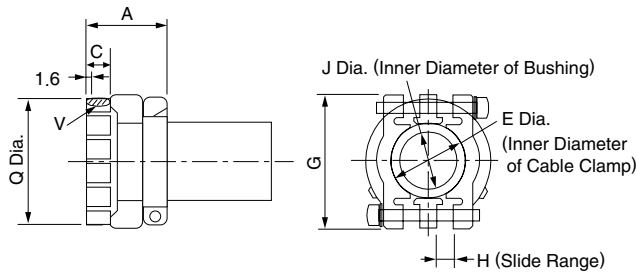

Cable Clamp Type	Applicable Connector Shell Size	Overall Length A±0.7	Effective Screw Length C	E Diameter	G±0.7	H	J Diameter	Set Screw V	Outer Diameter Q±0.7 Dia.	Attached Bushing
MS3057-10A	18	23.8	10.3	15.9	31.7	3.2	14.3	1-20UNEF	30.1	AN3420-10
MS3057-12A	20□22	23.8	10.3	19	37.3	4	15.9	1-3/16-18UNEF	35.0	AN3420-12
MS3057-20A	32	27.8	11.9	31.7	51.6	6.3	23.8	1-3/4-18UNS	51.6	AN3420-20

### • Dimensional Drawings of Brake Power Supply

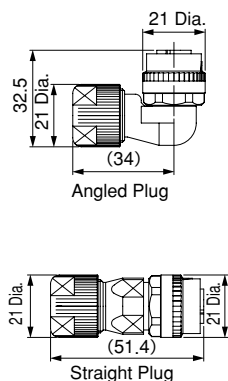

Items	Specifications
Connector Order No.	CM10-□P2S-□-D (Cables are not included.)
Protective Structure	IP67
Manufacturer	DDK Ltd.
Instructions	Angled plug (CM10-AP2S-□-D): TC-573, Straight plug (CM10-SP2S-□-D): TC-583
Electrical Contact Order No.	<p>Electrical contact (100 pcs in one bag)</p> <ul style="list-style-type: none"> <li>□Crimping type: CM10-#22SC(C3)-100, Wire size: AWG16 to 20, Outer diameter of sheath: 1.87 to 2.45 dia., Hand tool: 357J-50448T</li> <li>□Soldered type: CM10-#22SC (S2)-100, Wire size: AWG16 max.</li> </ul> <p>Real contact (4000 pcs on one reel)</p> <ul style="list-style-type: none"> <li>□Crimping type: CM10-#22SC(C3)-4000, Wire size: AWG 16 to 20, Outer diameter of sheath: 1.87 to 2.45 dia., Semi-automatic tool: AP-A50541T (product name for one set), AP-A50541T-1 (product name for applicator)</li> </ul> <p>Note: The product name of the semi-automatic tool refers to the product name of the press and applicator (crimper) as a set.</p>



Selecting Main Circuit Cables (SGMGV-09 to -1E)

● Protective Structure IP67 and European Safety Standards Compliant Connector

● Connector Configuration

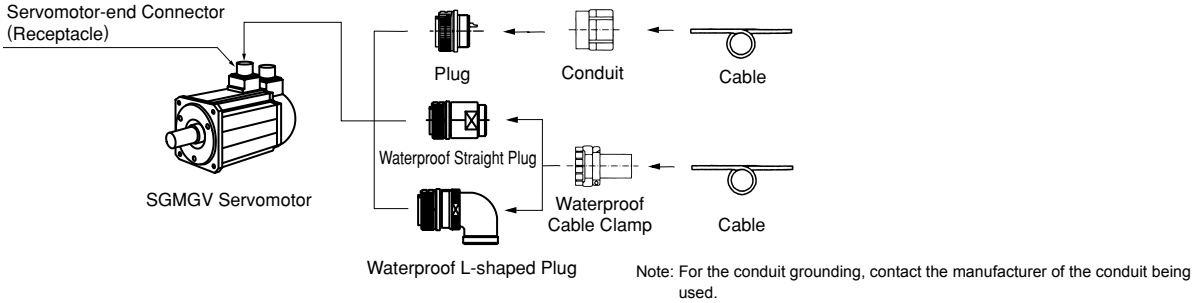

(1) Without Holding Brakes

Servomotor-end Connector  
For 0.85 to 15 kW

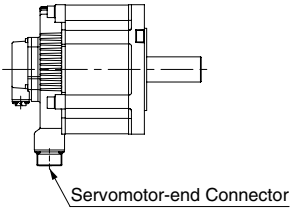
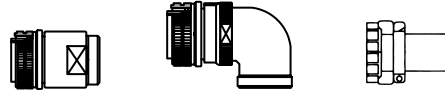

Capacity kW	Servomotor-end Connector (Receptacle)	Cable-end Connector (Not Provided by Yaskawa)			Applicable Cable Diameter (For Reference)	Manufacturer
		Straight Plug	L-shaped Plug	Cable Clamp		
0.85 1.3 1.8	CE05-2A18-10PD-D	CE05-6A18-10SD-D-BSS	CE05-8A18-10SD-D-BAS	CE3057-10A-1-D	10.5 dia. to 14.1 dia.	DDK Ltd.
				CE3057-10A-2-D	8.5 dia. to 11.0 dia.	
				CE3057-10A-3-D	6.5 dia. to 8.7 dia.	
2.9 4.4	CE05-2A22-22PD-D	CE05-6A22-22SD-D-BSS	CE05-8A22-22SD-D-BAS	CE3057-12A-1-D	12.5 dia. to 16.0 dia.	
				CE3057-12A-2-D	9.5 dia. to 13.0 dia.	
				CE3057-12A-3-D	6.8 dia. to 10.0 dia.	
				CE3057-12A-7-D	14.5 dia. to 17.0 dia.	
5.5 to 15	CE05-2A32-17PD-D	CE05-6A32-17SD-D-BSS	CE05-8A32-17SD-D-BAS	CE3057-20A-1-D	22 dia. to 23.8 dia.	
				CE3057-20A-2-D	24 dia. to 26.6 dia.	
				CE3057-20A-3-D	22 dia. to 22.5 dia.	

(2) With Holding Brakes

0.85 to 15 kW servomotors require servomotor-end connector and brake power supply connector.  
The servomotor-end connector is the same as is used for servomotors without holding brakes.

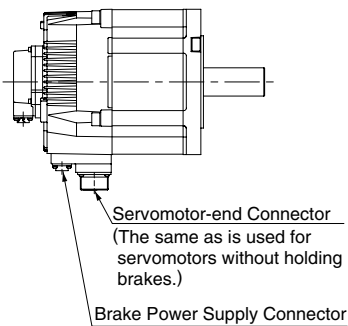

Brake Power Supply Connector  
0.85 to 15 kW

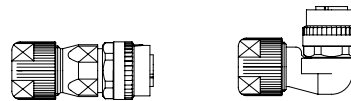

Capacity kW	Servomotor-end Connector (Receptacle)	Cable-end Connector (Not provided by Yaskawa)		Manufacturer
		Straight Plug	L-shaped Plug	
0.85 to 15	CM10-R2P-D	CM10-SP2S-S-D Applicable Cable: 4.0 dia. to 6.0 dia.	CM10-AP2S-S-D Applicable Cable: 4.0 dia. to 6.0 dia.	DDK Ltd.
		CM10-SP2S-M-D Applicable Cable: 6.0 dia. to 9.0 dia.	CM10-AP2S-M-D Applicable Cable: 6.0 dia. to 9.0 dia.	
		CM10-SP2S-L-D Applicable Cable: 9.0 dia. to 11.6 dia.	CM10-AP2S-L-D Applicable Cable: 9.0 dia. to 11.6 dia.	

To order a brake power supply connector kit (0.85 to 15 kW) with the order no. below, contact your Yaskawa representative.

JZSP - CVB9 - S M S2 - E

Connector Type: S: Straight plug, A: L-shaped plug  
 Bush Size<sup>\*1</sup>: S: Size S (4.0 dia. to 6.0 dia.), M: Size M (6.0 dia. to 9.0 dia.), L: Size L (9.0 dia. to 11.6 dia.)  
 Contact Pin Size: S2: Soldered, C3: Crimping type<sup>\*2</sup>

\*1: A size-M connector kit is available as a standard equipment.  
 \*2: A crimp tool (model: 357J-50448T) by DDK Ltd. is required.

# Selecting Encoder Cables

● Encoder Cables (Max. length: 20 m)

■ Non-Stock Items

Name	Length (L)	Order No.		Specifications	Details
		Standard Type	Flexible Type*		
Encoder Cable with Connectors (For Incremental Encoder)	3 m	JZSP-CVP01-03-E	JZSP-CVP11-03-E	<p>SERVOPACK End <math>\xrightarrow{L}</math> Encoder End</p> <p>Connector (Crimped) (Molex Japan Co., Ltd.) CM10-SP10S-□-D (DDK Ltd.)</p>	(1)
	5 m	JZSP-CVP01-05-E	JZSP-CVP11-05-E		
	10 m	JZSP-CVP01-10-E	JZSP-CVP11-10-E		
	15 m	JZSP-CVP01-15-E	JZSP-CVP11-15-E		
	20 m	JZSP-CVP01-20-E	JZSP-CVP11-20-E		
	3 m	JZSP-CVP02-03-E	JZSP-CVP12-03-E	<p>SERVOPACK End <math>\xrightarrow{L}</math> Encoder End</p> <p>Connector (Crimped) (Molex Japan Co., Ltd.) CM10-AP10S-□-D (DDK Ltd.)</p>	(1)
	5 m	JZSP-CVP02-05-E	JZSP-CVP12-05-E		
	10 m	JZSP-CVP02-10-E	JZSP-CVP12-10-E		
	15 m	JZSP-CVP02-15-E	JZSP-CVP12-15-E		
	20 m	JZSP-CVP02-20-E	JZSP-CVP12-20-E		
Encoder Cable with Connectors (For Absolute Encoder, with a Battery Case)	3 m	JZSP-CVP06-03-E	JZSP-CVP26-03-E	<p>SERVOPACK End <math>\xrightarrow{L}</math> Encoder End</p> <p>Connector (Crimped) (Molex Japan Co., Ltd.) CM10-SP10S-□-D (DDK Ltd.)</p> <p>Battery Case (Battery Attached)</p>	(2)
	5 m	JZSP-CVP06-05-E	JZSP-CVP26-05-E		
	10 m	JZSP-CVP06-10-E	JZSP-CVP26-10-E		
	15 m	JZSP-CVP06-15-E	JZSP-CVP26-15-E		
	20 m	JZSP-CVP06-20-E	JZSP-CVP26-20-E		
	3 m	JZSP-CVP07-03-E	JZSP-CVP27-03-E	<p>SERVOPACK End <math>\xrightarrow{L}</math> Encoder End</p> <p>Connector (Crimped) (Molex Japan Co., Ltd.) CM10-AP10S-□-D (DDK Ltd.)</p> <p>Battery Case (Battery Attached)</p>	(2)
	5 m	JZSP-CVP07-05-E	JZSP-CVP27-05-E		
	10 m	JZSP-CVP07-10-E	JZSP-CVP27-10-E		
	15 m	JZSP-CVP07-15-E	JZSP-CVP27-15-E		
	20 m	JZSP-CVP07-20-E	JZSP-CVP27-20-E		
SERVOPACK-end Connector Kit		JZSP-CMP9-1-E		<p>Soldered</p> <p>(Molex Japan Co., Ltd.)</p>	(3)
Encoder-end Connectors for Protective Structure IP67 Straight Plug	JZSP-CVP9-1-E		<p>Connector Specifications</p> <p>Plug: CM10-SP10S-M-D</p> <p>Electrical Contact: (Crimped)**</p> <p>CM10-#22SC(C4)-100</p> <p>Applicable Cable Diameter: 6.0 dia. to 9.0 dia.</p>	<p>Straight plug</p> <p>+ Electrical Contact</p> <p>(DDK Ltd.)</p>	-
	JZSP-CVP9-3-E		<p>Connector Specifications</p> <p>Plug: CM10-SP10S-M-D</p> <p>Electrical Contact: (Soldered)</p> <p>CM10-#22SC(S1)-100</p> <p>Applicable Cable Diameter: 6.0 dia. to 9.0 dia.</p>		
Encoder-end Connectors for Protective Structure IP67 L-shaped Plug	JZSP-CVP9-2-E		<p>Connector Specifications</p> <p>Plug: CM10-AP10S-M-D</p> <p>Electrical Contact: (Crimped)**</p> <p>CM10-#22SC(C4)-100</p> <p>Applicable Cable Diameter: 6.0 dia. to 9.0 dia.</p>	<p>L-shaped plug</p> <p>+ Electrical Contact</p> <p>(DDK Ltd.)</p>	-
	JZSP-CVP9-4-E		<p>Connector Specifications</p> <p>Plug: CM10-AP10S-M-D</p> <p>Electrical Contact: (Soldered)</p> <p>CM10-#22SC(S1)-100</p> <p>Applicable Cable Diameter: 6.0 dia. to 9.0 dia.</p>		
Cables	3 m	JZSP-CMP09-03-E	JZSP-CSP39-03-E		(4)
	5 m	JZSP-CMP09-05-E	JZSP-CSP39-05-E		
	10 m	JZSP-CMP09-10-E	JZSP-CSP39-10-E		
	15 m	JZSP-CMP09-15-E	JZSP-CSP39-15-E		
	20 m	JZSP-CMP09-20-E	JZSP-CSP39-20-E		

\* Use flexible cables for movable sections such as robot arms.

\*\* A crimp tool (357J-52667T) is required

Selecting Encoder Cables

(1) Wiring Specifications for Cable with Connectors (For incremental encoder)

· Standard Type

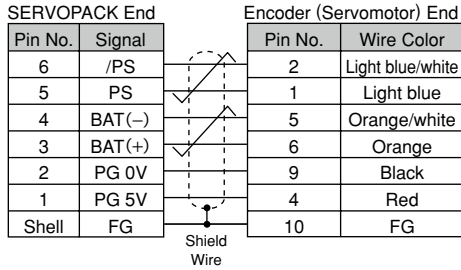

· Flexible Type

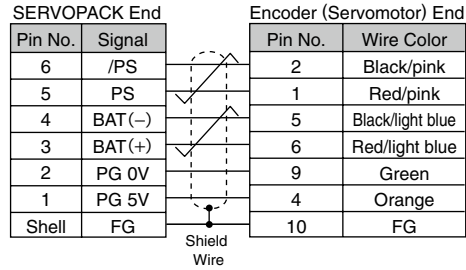

(2) Wiring Specifications for Cable with Connectors (For absolute encoder, with a battery case)

· Standard Type

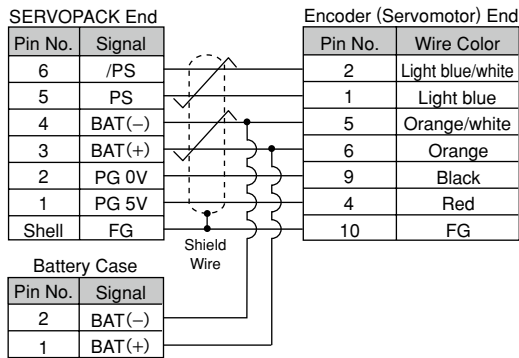

· Flexible Type

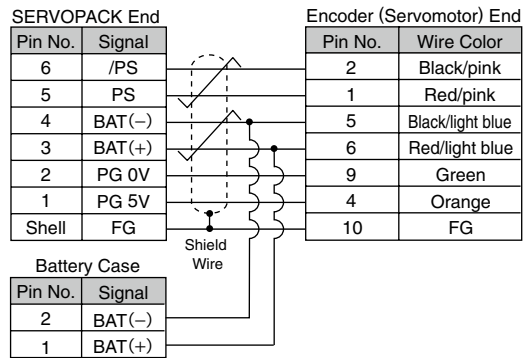

(3) SERVOPACK-end Connector Kit Specifications

Items	Specifications
Order No.	JZSP-CMP9-□□-E
Manufacturer	Molex Japan Co., Ltd.
Connector Model (For standard)	55100-0670 (soldered)
External Dimensions (Units: mm)	

Note: The mating connector model on SERVOPACK: 54280-800  
The mating connector model on servomotor: 55102-0600

(4) Cable Specifications

Items	Standard Type	Flexible Type
Order No.*	JZSP-CMP09-□□-E	JZSP-CSP39-□□-E
Cable Length	20 m max.	
Specifications	UL20276 (Max. operating temperature: 80°C) AWG22×2C + AWG24×2P AWG22 (0.33 mm <sup>2</sup> ) Outer diameter of insulating sheath: 1.15 dia. AWG24 (0.20 mm <sup>2</sup> ) Outer diameter of insulating sheath: 1.09 dia.	UL20276 (Max. operating temperature: 80°C) AWG22×2C + AWG24×2P AWG22 (0.33 mm <sup>2</sup> ) Outer diameter of insulating sheath: 1.35 dia. AWG24 (0.20 mm <sup>2</sup> ) Outer diameter of insulating sheath: 1.21 dia.
Finished Dimensions	6.5 dia.	6.8 dia.
Internal Configuration and Lead Color		
Yaskawa Standards Specifications (Standard Length)	Cable length: 5 m, 10 m, 15 m, 20 m	

\*: Specify the cable length in □□ of order no.  
Example: JZSP-CMP09-05-E (5 m)

## Selecting Encoder Cables

### ● Encoder Cables (For extending from 30 to 50 m)

■ Limited Stock Items

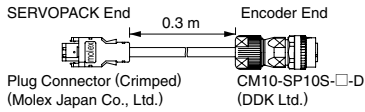
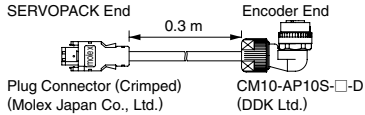
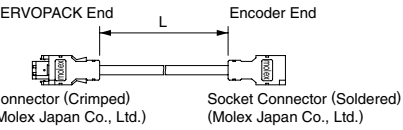
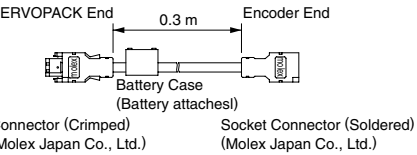
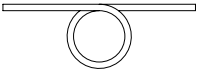
Name	Length	Order No.	Specifications	Details
① Encoder-end Cables (For incremental and absolute encoder)	0.3 m	JZSP-CVP01-E	 <p>SERVOPACK End      0.3 m      Encoder End</p> <p>Plug Connector (Crimped)      CM10-SP10S-□-D (Molex Japan Co., Ltd.)      (DDK Ltd.)</p>	(1)
		JZSP-CVP02-E	 <p>SERVOPACK End      0.3 m      Encoder End</p> <p>Plug Connector (Crimped)      CM10-AP10S-□-D (Molex Japan Co., Ltd.)      (DDK Ltd.)</p>	
② Cable with Connectors (For incremental and absolute encoder)	30 m	JZSP-UCMP00-30-E	 <p>SERVOPACK End      L      Encoder End</p> <p>Connector (Crimped)      Socket Connector (Soldered) (Molex Japan Co., Ltd.)      (Molex Japan Co., Ltd.)</p>	(2)
	40 m	JZSP-UCMP00-40-E		
	50 m	JZSP-UCMP00-50-E		
③ Cable with a Battery Case (Required when an absolute encoder is used.)	0.3 m	JZSP-CSP12-E*	 <p>SERVOPACK End      0.3 m      Encoder End</p> <p>Connector (Crimped)      Battery Case      Socket Connector (Soldered) (Molex Japan Co., Ltd.)      (Battery attaches!)      (Molex Japan Co., Ltd.)</p>	(3)
④ Cables	30 m	JZSP-CMP19-30-E		(4)
	40 m	JZSP-CMP19-40-E		
	50 m	JZSP-CMP19-50-E		

\*: When using an incremental encoder or using an absolute encoder with a battery connected to the host controller, no battery case is required.

Selecting Encoder Cables

(1) Wiring Specifications for Encoder-end Cable  
(For incremental and absolute encoder)

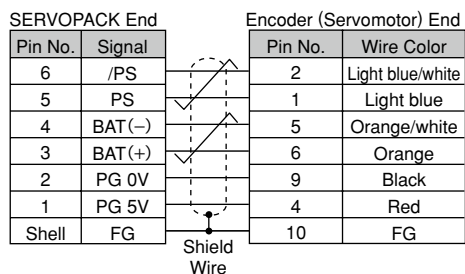

Note: The signals BAT(+) and BAT(-) are used when using an absolute encoder.

(2) Wiring Specifications for Cable with Connectors  
(For incremental and absolute encoder)

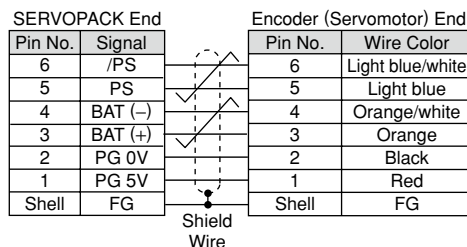

(3) Wiring Specifications for Cable with a Battery Case  
(For absolute encoder)

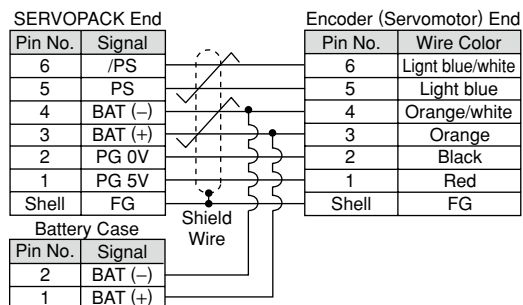

(4) Cable Specifications

Item	Standard Type
Order No.*	JZSP-CMP19-□□-E
Cable Length	50 m max.
Specifications	UL20276 (Max. operating temperature: 80°C) AWG16×2C+AWG26×2P AWG16 (1.31 mm <sup>2</sup> ) Outer diameter of insulating sheath: 2.0 dia. AWG26 (0.13 mm <sup>2</sup> ) Outer diameter of insulating sheath: 0.91 dia.
Finished Dimensions	6.8 dia.
Internal Configuration and Lead Colors	
Yaskawa Standard Specifications (Standard Length)	Cable length: 30 m, 40 m, 50 m

\*: Specify the cable length in □□ of order no.  
Example: JZSP-CMP19-30-E (30 m)

# Rotary Servomotors

# SGMSV

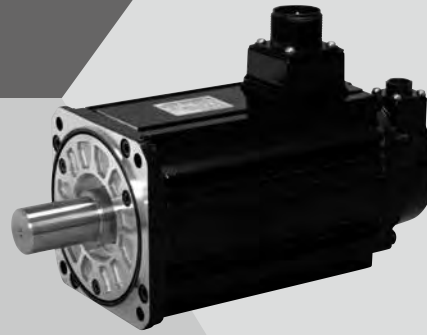

## Model Designations

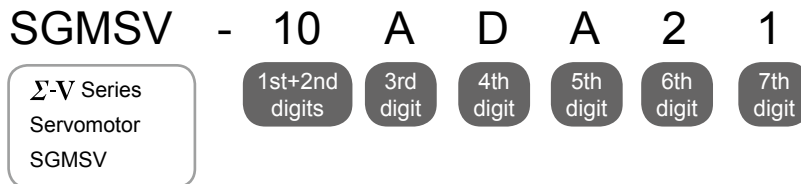

### 1st+2nd digits Rated Output

Code	Specifications
10	1.0 kW
15	1.5 kW
20	2.0 kW
25	2.5 kW
30	3.0 kW
40	4.0 kW
50	5.0 kW
70	7.0 kW*

\*: Available only for 200-VAC models without brake.

### 3rd digit Power Supply Voltage

Code	Specifications
A	200 VAC
D	400 VAC

### 4th digit Serial Encoder

Code	Specifications
3	20-bit absolute
D	20-bit incremental

### 5th digit Design Revision Order

Code	Specifications
A	Standard

### 6th digit Shaft End

Code	Specifications
2	Straight without key
6	Straight with key and tap

### 7th digit Options

Code	Specifications
1	Without options
B	With holding brake (90 VDC)
C	With holding brake (24 VDC)
D	With oil seal and holding brake (90 VDC)
E	With oil seal and holding brake (24 VDC)
S	With oil seal

Limited Stock Items
  Non-Stock Items

## Features

- Super high power
- Wide selection: 1.0 kW to 7.0 kW capacity, holding brake option
- Mounted serial encoder: 20 bits, high resolution
- Protective structure: IP67 (Not including the IP22 compliant enclosure for 7.0 kW motor)

## Application Examples

- Chip mounters
- PCB drilling stations
- Machine tool feeders

## Configurations of connectors for the main circuit

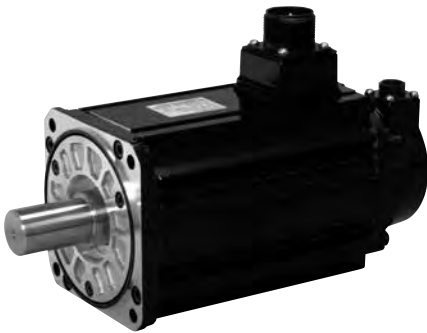

### SGMSV-10 to -70

The connectors for these models are round. The connectors specified by Yaskawa are required. Note that the connectors vary depending on the operation environment of servomotors.

Two types of connectors are available.

- Standard connectors.
- Protective structure IP67 and European Safety Standards compliant connectors

Note: Connectors are not provided by Yaskawa.



## Ratings and Specifications

Time Rating: Continuous  
 Vibration Class: V15  
 Insulation Resistance: 500 VDC, 10 MΩ min.  
 Ambient Temperature: 0 to 40°C  
 Excitation: Permanent magnet  
 Mounting: Flange-mounted  
 Thermal Class: F

Withstand Voltage: 1500 VAC for one minute (200-V class)  
 1800 VAC for one minute (400-V class)

Enclosure: Totally enclosed, self-cooled, IP67  
 (except for shaft opening)

Note: IP22 for SGMSV-70 servomotors.

Ambient Humidity: 20% to 80% (no condensation)

Drive Method: Direct drive

Rotation Direction: Counterclockwise (CCW) with forward run reference  
 when viewed from the load side

### 200-V Class

Servomotor Model: SGMSV-□□□□		10A	15A	20A	25A	30A	40A	50A	70A
Rated Output*	kW	1.0	1.5	2.0	2.5	3.0	4.0	5.0	7.0
Rated Torque*	N·m	3.18	4.90	6.36	7.96	9.80	12.6	15.8	22.3
Instantaneous Peak Torque*	N·m	9.54	14.7	19.1	23.9	29.4	37.8	47.6	54
Rated Current*	$A_{rms}$	5.7	9.3	12.1	13.8	17.9	25.4	27.6	38.3
Instantaneous Max. Current*	$A_{rms}$	17	28	42	44.5	56	77	84	105
Rated Speed*	$min^{-1}$	3000							
Max. Speed*	$min^{-1}$	6000	5000						
Torque Constant	N·m/ $A_{rms}$	0.636	0.590	0.561	0.610	0.582	0.519	0.604	0.604
Rotor Moment of Inertia	$\times 10^{-4}$ kg·m <sup>2</sup>	1.74 (1.99)	2.00 (2.25)	2.47 (2.72)	3.19 (3.44)	7.00 (9.2)	9.60 (11.8)	12.3 (14.5)	12.3
Rated Power Rate*	kW/s	58 (51)	120 (107)	164 (149)	199 (184)	137 (104)	165 (135)	203 (172)	404
Rated Angular Acceleration*	rad/s <sup>2</sup>	18300 (16000)	24500 (21800)	25700 (23400)	25000 (23100)	14000 (10700)	13100 (10700)	12800 (10900)	18100
Applicable SERVOPACK	SGDV-□□□□	7R6A	120A	180A	200A	200A	330A	330A	550A

\*: These items and torque-motor speed characteristics quoted in combination with a SERVOPACK are at an armature winding temperature of 20°C.

Notes: 1 The values in parentheses are for servomotors with holding brakes.

2 The above specifications show the values under the cooling condition when the following heat sinks are mounted on the servomotors.

SGMSV-10A/-15A/-20A/-25A : 300 mm×300 mm×12 mm (aluminum)

SGMSV-30A/-40A/-50A/-70A : 400 mm×400 mm×20 mm (aluminum)

### 400-V Class

Servomotor Model: SGMSV-□□□□		10D	15D	20D	25D	30D	40D	50D
Rated Output*	kW	1.0	1.5	2.0	2.5	3.0	4.0	5.0
Rated Torque*	N·m	3.18	4.9	6.36	7.96	9.8	12.6	15.8
Instantaneous Peak Torque*	N·m	9.54	14.7	19.1	23.9	29.4	37.8	47.6
Rated Current*	$A_{rms}$	2.8	4.7	6.1	7.4	8.9	12.5	13.8
Instantaneous Max. Current*	$A_{rms}$	8.5	14	20	25	28	38	42
Rated Speed*	$min^{-1}$	3000						
Max. Speed*	$min^{-1}$	6000	5000					
Torque Constant	N·m/ $A_{rms}$	1.27	1.23	1.18	1.15	1.16	1.06	1.21
Rotor Moment of Inertia	$\times 10^{-4}$ kg·m <sup>2</sup>	1.74 (1.99)	2.00 (2.25)	2.47 (2.72)	3.19 (3.44)	7.00 (9.2)	9.60 (11.8)	12.3 (14.5)
Rated Power Rate*	kW/s	58 (51)	120 (107)	164 (149)	199 (184)	137 (104)	165 (135)	203 (172)
Rated Angular Acceleration*	rad/s <sup>2</sup>	18300 (16000)	24500 (21800)	25700 (23400)	25000 (23100)	14000 (10700)	13100 (10700)	12800 (10900)
Applicable SERVOPACK	SGDV-□□□□	3R5D	5R4D	8R4D	120D	120D	170D	170D

\*: These items and torque-motor speed characteristics quoted in combination with a SERVOPACK are at an armature winding temperature of 20°C.

Notes: 1 The values in parentheses are for servomotors with holding brakes.

2 The above specifications show the values under the cooling condition when the following heat sinks are mounted on the servomotors.

SGMSV-10D/-15D/-20D/-25D : 300 mm×300 mm×12 mm (aluminum)

SGMSV-30D/-40D/-50D : 400 mm×400 mm×20 mm (aluminum)

**Ratings and Specifications**

● Torque-Motor Speed Characteristics(200 V/400 V) **A**: Continuous Duty Zone **B**: Intermittent Duty Zone (Note1)

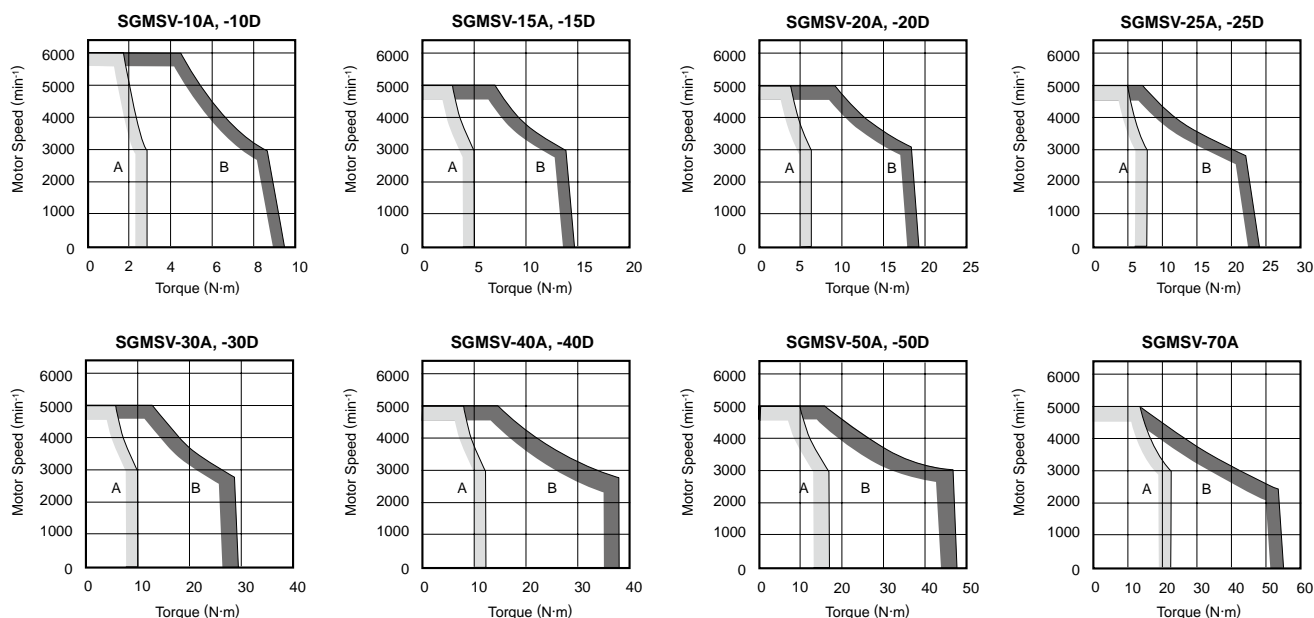

Note: 1 When the effective torque during intermittent duty is within the rated torque, the servomotor can be used within the intermittent duty zone.  
 2 When the main circuit cable length exceeds 20 m, note that the intermittent duty zone of the Torque-Motor Speed Characteristics will shrink as the line-to-line voltage drops.

● Holding Brake Electrical Specifications

Servomotor Model	Servomotor Rated Output kW	Holding Brake Specifications				
		Holding Torque N·m	Rated Voltage 24 VDC		Rated Voltage 90 VDC	
			Capacity W	Rated Current A (at 20°C)	Capacity W	Rated Current A (at 20°C)
SGMSV-10	1.0	7.84	12	0.5	12	0.13
SGMSV-15	1.5	7.84	12	0.5	12	0.13
SGMSV-20	2.0	7.84	12	0.5	12	0.13
SGMSV-25	2.5	10	12	0.5	12	0.13
SGMSV-30	3.0	20	10	0.41	10	0.11
SGMSV-40	4.0	20	10	0.41	10	0.11
SGMSV-50	5.0	20	10	0.41	10	0.11

Notes: 1 The holding brake is only used to hold the load and cannot be used to stop the servomotor.  
 2 The holding brake open time and holding brake operation time vary depending on which discharge circuit is used. Make sure holding brake open time and holding brake operation time are correct for your servomotor.  
 3 A 24 VDC power supply is to be provided by customers.

## Ratings and Specifications

### ● Allowable Load Moment of Inertia at the Motor Shaft

The rotor moment of inertia ratio is the value for a servomotor without a gear and a holding brake.

Servomotor Model	Servomotor Rated Output	Allowable Load Moment of Inertia (Rotor Moment of Inertia Ratio)
SGMSV-10 to -70	1.0 to 7.0 kW	5 times

### ● Load Moment of Inertia

The larger the load moment of inertia, the worse the movement response.

The allowable load moment of inertia ( $J_L$ ) depends on motor capacity, as shown above. This value is provided strictly as a guideline and results may vary depending on servomotor drive conditions.

Use the AC servo drive capacity selection program SigmaJunmaSize+ to check the operation conditions.

The program can be downloaded for free from our web site (<http://www.e-mechatronics.com/>).

An overvoltage alarm (A.400) is likely to occur during deceleration if the load moment of inertia exceeds the allowable load moment of inertia. SERVOPACKs with a built-in regenerative resistor may generate a regenerative overload alarm (A.320). Take one of the following steps if this occurs.

- Reduce the torque limit.
- Reduce the deceleration rate.
- Reduce the maximum speed.
- Install an external regenerative resistor if the alarm cannot be cleared using the steps above. Refer to Regenerative Resistors on page 386.

### ● Allowable Radial and Thrust Loads

Design the mechanical system so thrust and radial loads applied to the servomotor shaft end during operation fall within the ranges shown in the table.

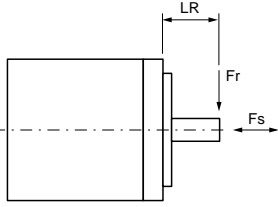
Servomotor Model		Allowable Radial Load ( $F_r$ ) N	Allowable Thrust Load ( $F_s$ ) N	LR mm	Reference Diagram
SGMSV-	10□□A21	686	196	45	
	15□□A21				
	20□□A21				
	25□□A21	980	392	63	
	30□□A21				
	40□□A21	1176	392	63	
	50□□A21				
70□□A21					

**External Dimensions** Units: mm

● Without Holding Brakes

(1) 1.0 to 5.0 kW

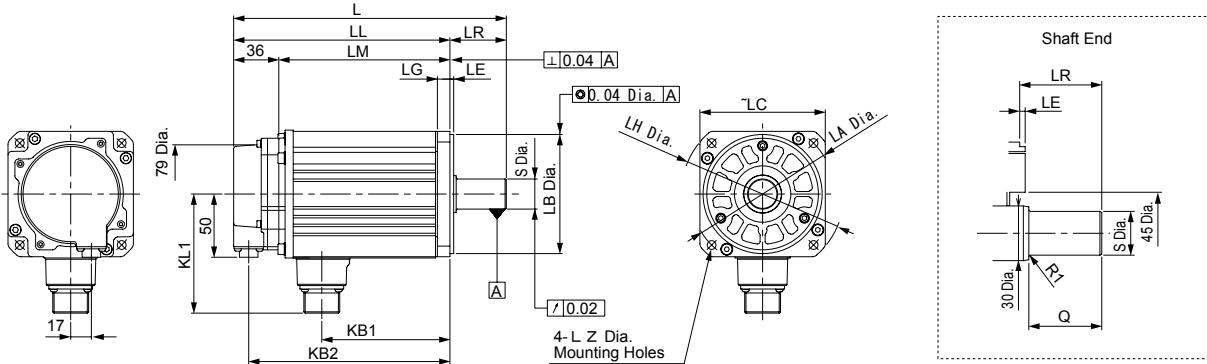

Note: For the specifications of the other shaft ends, refer to page 79.

Model SGMSV-	L	LL	LM	LR	KB1	KB2	KL1	Flange Face Dimensions								Shaft End Dimensions		Approx. Mass kg
								LA	LB	LC	LE	LF	LG	LH	LZ	S	Q	
10□□A21	192	147	111	45	76	135	96	115	95 <sup>0</sup> <sub>-0.035</sub>	100	3	3	10	130	7	24 <sup>0</sup> <sub>-0.013</sub>	40	4.1
15□□A21	202	157	121	45	86	145	96	115	95 <sup>0</sup> <sub>-0.035</sub>	100	3	3	10	130	7	24 <sup>0</sup> <sub>-0.013</sub>	40	4.6
20□□A21	218	173	137	45	102	161	96	115	95 <sup>0</sup> <sub>-0.035</sub>	100	3	3	10	130	7	24 <sup>0</sup> <sub>-0.013</sub>	40	5.4
25□□A21	241	196	160	45	125	184	96	115	95 <sup>0</sup> <sub>-0.035</sub>	100	3	3	10	130	7	24 <sup>0</sup> <sub>-0.013</sub>	40	6.8
30□□A21	259	196	160	63	124	184	114	145	110 <sup>0</sup> <sub>-0.035</sub>	130	6	6	12	165	9	28 <sup>0</sup> <sub>-0.013</sub>	55	10.5
40□□A21	296	233	197	63	161	221	114	145	110 <sup>0</sup> <sub>-0.035</sub>	130	6	6	12	165	9	28 <sup>0</sup> <sub>-0.013</sub>	55	13.5
50□□A21	336	273	237	63	201	261	114	145	110 <sup>0</sup> <sub>-0.035</sub>	130	6	6	12	165	9	28 <sup>0</sup> <sub>-0.013</sub>	55	16.5

Note: Models with oil seals are of the same configuration.

· Cable Specifications for Encoder-end Connector (20-bit Encoder)

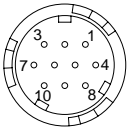

Receptacle: CM10-R10P-D  
 Applicable plug (To be provided by the customer)  
 Plug: CM10-AP10S-□-D (Angle)  
 CM10-SP10S-□-D (Straight)  
 (Boxes □ indicate a value that varies, depending on cable size.)  
 Manufacturer: DDK Ltd.

With an Absolute Encoder

1	PS	6	BAT (+)
2	/PS	7	-
3	-	8	-
4	PG 5V	9	PG 0V
5	BAT (-)	10	FG (Frame ground)

With an Incremental Encoder

1	PS	6	-
2	/PS	7	-
3	-	8	-
4	PG 5V	9	PG 0V
5	-	10	FG (Frame ground)

· Cable Specifications for Servomotor-end Connector

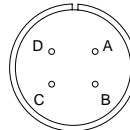

A	Phase U
B	Phase V
C	Phase W
D	FG (Frame ground)

· SGMSV-10 to -25  
 Manufacturer: DDK Ltd.  
 · SGMSV-30 to -50  
 Manufacturer: Japan Aviation Electronics Industry, Ltd.

# External Dimensions Units: mm

## (2) 7.0 kW (only for 200 V servomotors)

- Notes: 1 Leave a minimum space of 70 mm around the servomotor to allow for a sufficient amount of cooling air.  
 2 Cooling Fan : single-phase 220 V, 50/60Hz, 17/15 W, 0.11/0.09 A

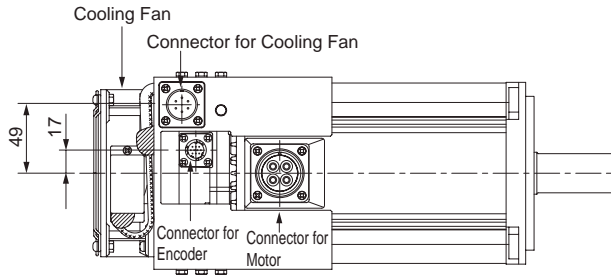
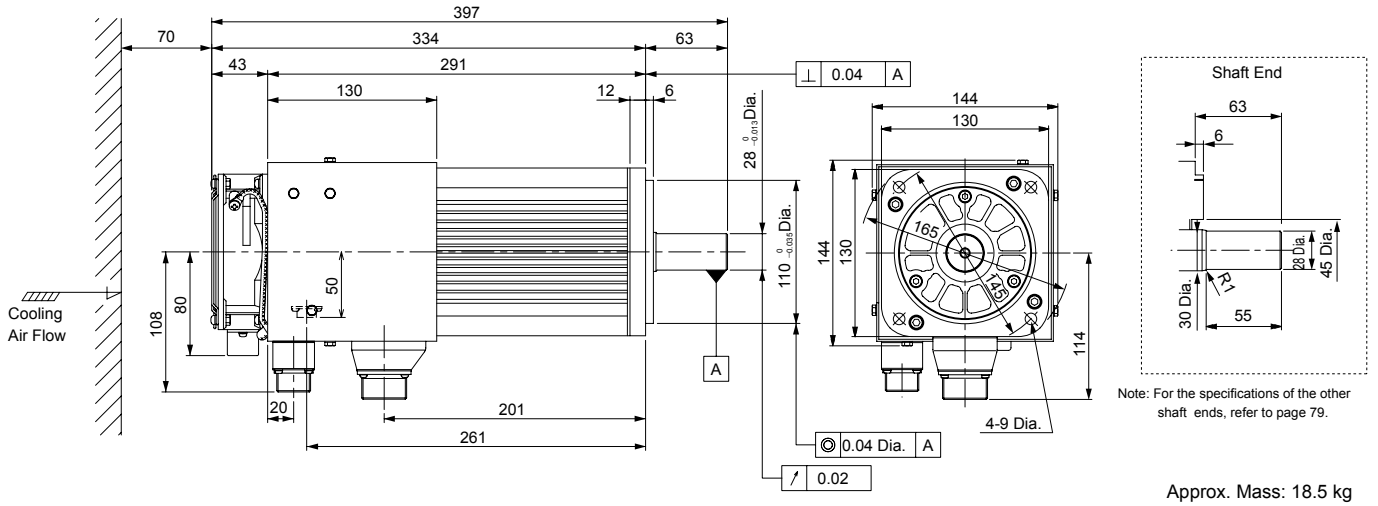

### · Cable Specifications for Servomotor-end Connector

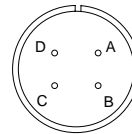

A	Phase U
B	Phase V
C	Phase W
D	FG (Frame ground)

Manufacturer: Japan Aviation Electronics Industry, Ltd.

### · Cable Specifications for Fan-end Connector

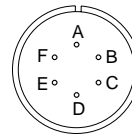

Receptacle: MS3102A14S-6P  
 Applicable plug  
 Plug: MS3108B14S-6S  
 Cable clamp: MS3057-6A

Note: Servomotor-end connectors (receptacles) are RoHS-compliant. Contact the respective connector manufacturers for RoHS-compliant cable-end connectors.

- Specifications of Cooling Fan
  - Single-phase 220 V
  - 50/60 Hz
  - 17/15 W
  - 0.11/0.09 A
- Specifications of rotation error detector
  - Contact Capacity:
    - Max. allowable voltage: 350 V (AC, DC)
    - Max. allowable current: 120 mA (AC, DC)
    - Max. controllable power: 360 mW
  - Alarm Contact:
    - ON at normal fan rotation.
    - OFF at 1680±100 min<sup>-1</sup> or less.
    - (OFF during 3 seconds at start-up)

### · Cable Specifications for Encoder-end Connector (20-bit Encoder)

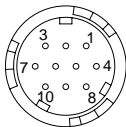

Receptacle: CM10-R10P-D  
 Applicable plug (To be provided by the customer)  
 Plug: CM10-SP10S-□-D (Straight)  
 (Boxes (□) indicate a value that varies, depending on cable size.)

Use straight plugs to avoid interference with the fan cover.  
 Manufacturer: DDK Ltd.

A	Fan motor
B	Fan motor
C	—
D	Alarm terminal
E	Alarm terminal
F	FG (Frame ground)

### With an Absolute Encoder

1	PS	6	BAT (+)
2	/PS	7	—
3	—	8	—
4	PG 5V	9	PG 0V
5	BAT (-)	10	FG (Frame ground)

### With an Incremental Encoder

1	PS	6	—
2	/PS	7	—
3	—	8	—
4	PG 5V	9	PG 0V
5	—	10	FG (Frame ground)

## External Dimensions Units: mm

### ● With Holding Brakes

(1) 1.0 to 5.0 kW

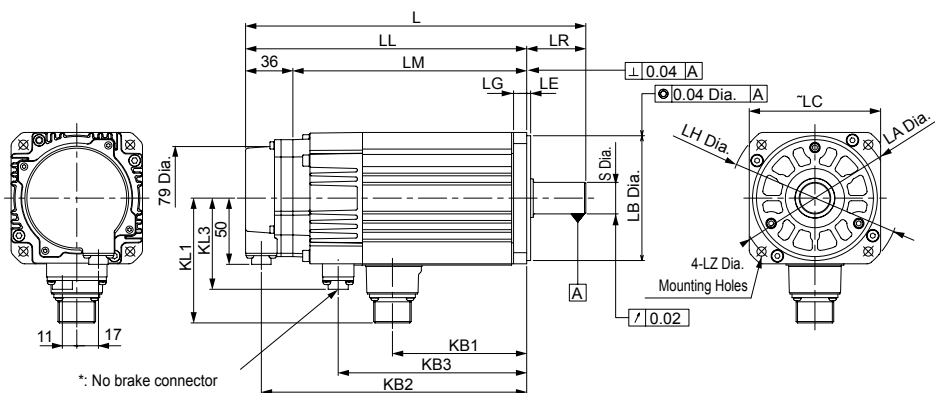

\*: No brake connector for 200-V models.

Note: For the specifications of the other shaft ends, refer to page 79.

Model SGMSV-	L	LL	LM	LR	KB1		KB2	KB3*	KL1	KL3*	Flange Face Dimensions							Shaft End Dimensions		Approx. Mass □		
					200V	400V					LA	LB	LC	LE	LF	LG	LH	LZ	S		Q	
10□□A2□	233	188	152	45	67	76	176	118	102	96	69	115	95 <sup>0</sup> <sub>0.035</sub>	100	3	3	10	130	7	24 <sup>0</sup> <sub>0.013</sub>	40	5.5
15□□A2□	243	198	162	45	77	86	186	128	102	96	69	115	95 <sup>0</sup> <sub>0.035</sub>	100	3	3	10	130	7	24 <sup>0</sup> <sub>0.013</sub>	40	6
20□□A2□	259	214	178	45	93	102	202	144	102	96	69	115	95 <sup>0</sup> <sub>0.035</sub>	100	3	3	10	130	7	24 <sup>0</sup> <sub>0.013</sub>	40	6.8
25□□A2□	292	247	211	45	116	125	225	177	102	96	69	115	95 <sup>0</sup> <sub>0.035</sub>	100	3	3	10	130	7	24 <sup>0</sup> <sub>0.013</sub>	40	8.7
30□□A2□	295	232	196	63	114	124	220	176	119	114	81	145	110 <sup>0</sup> <sub>0.035</sub>	130	6	6	12	165	9	28 <sup>0</sup> <sub>0.013</sub>	55	13
40□□A2□	332	269	233	63	151	161	257	213	119	114	81	145	110 <sup>0</sup> <sub>0.035</sub>	130	6	6	12	165	9	28 <sup>0</sup> <sub>0.013</sub>	55	16
50□□A2□	372	309	273	63	191	201	297	253	119	114	81	145	110 <sup>0</sup> <sub>0.035</sub>	130	6	6	12	165	9	28 <sup>0</sup> <sub>0.013</sub>	55	19

\*: No brake connector for 200-V models (there are brake terminals on the servomotor-end connectors).  
Note: Models with oil seals are of the same configuration.

#### · Cable Specifications for Encoder-end Connector (20-bit Encoder)

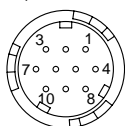

Receptacle: CM10-R10P-D  
Applicable plug (To be provided by the customer)  
Plug: CM10-AP10S-□-D (Angle)  
CM10-SP10S-□-D (Straight)  
(Boxes (□) indicate a value that varies, depending on cable size.)  
Manufacturer: DDK Ltd.

With an Absolute Encoder

1	PS	6	BAT (+)
2	/PS	7	-
3	-	8	-
4	PG 5V	9	PG 0V
5	BAT (-)	10	FG (Frame ground)

With an Incremental Encoder

1	PS	6	-
2	/PS	7	-
3	-	8	-
4	PG 5V	9	PG 0V
5	-	10	FG (Frame ground)

#### 200-V Class

##### · Cable Specifications for Servomotor-end Connector

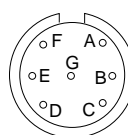

A	Phase U
B	Phase V
C	Phase W
D	FG (Frame ground)
E	Brake terminal
F	Brake terminal
G	-

Manufacturer: Japan Aviation Electronics Industry, Ltd.

Note: No polarity for connection to the brake terminals

#### 400-V Class

##### · Cable Specifications for Servomotor-end Connector

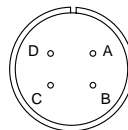

A	Phase U
B	Phase V
C	Phase W
D	FG (Frame ground)

· SGMSV-10 to -25  
Manufacturer: DDK Ltd.  
· SGMSV-30 to -50  
Manufacturer: Japan Aviation Electronics Industry, Ltd.

##### · Cable Specifications for Brake-end Connector

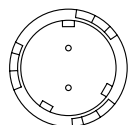

Receptacle: CM10-R2P-D  
Applicable plug (To be provided by the customer)  
Plug: CM10-AP2S-□-D (Angle)  
CM10-SP2S-□-D (Straight)  
(Boxes (□) indicate a value that varies, depending on cable size.)  
Manufacturer: DDK Ltd.

Brake terminal
Brake terminal

Note: No polarity for connection to the brake terminals

**External Dimensions** Units: mm

● Shaft End

SGMSV - □□□□□□□

Code	Specifications	Remarks
2	Straight without key	Optional/Non-stock
6	Straight with key and tap for one location (Key slot is JIS B1301-1996 fastening type)	Standard/Stock

Code	Specifications	Shaft End	Model SGMSV-							
			10	15	20	25	30	40	50	70
2	Straight without Key		LR	45			63			
			Q	40			55			
			S	24 <sup>0</sup> <sub>-0.013</sub>			28 <sup>0</sup> <sub>-0.013</sub>			
6	Straight with Key and Tap		LR	45			63			
			Q	40			55			
			QK	32			50			
			S	24 <sup>0</sup> <sub>-0.013</sub>			28 <sup>0</sup> <sub>-0.013</sub>			
			W				8			
			T				7			
			U				4			
P				M8 Screw Depth16						

Selecting Cables

● Cables Connections

● Standard Wiring (Max. encoder cable length: 20 m)

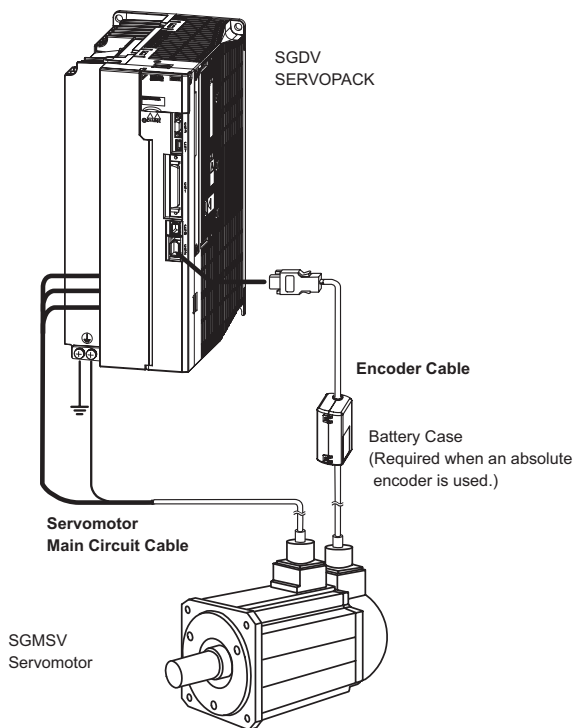

● Encoder Cable Extension from 30 to 50 m

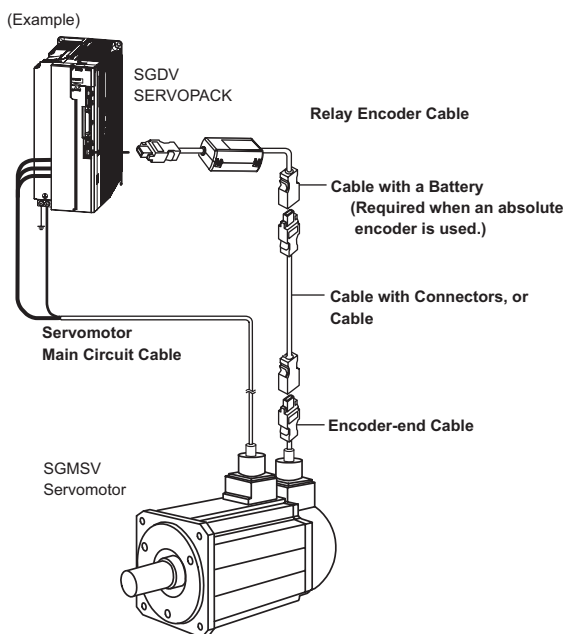

**CAUTION**

- Separate the servomotor main circuit cable wiring from the I/O signal cable and encoder cable at least 30 cm, and do not bundle or run them in the same duct.
- When the main circuit cable length exceeds 20 m, note that the intermittent duty zone of the Torque-Motor Speed Characteristics will shrink as the line-to-line voltage drops.



# Selecting Cables

## ● Servomotor Main Circuit Cables

Voltage	Name	Servomotor Rated Output	Length	Order No.		Specifications	Details
				Value Type	Premium Type <sup>*2</sup>		
200V	Servomotor Power Cable (for Servomotor without Holding Brake)	1.0kW to 2.5kW	3 m	B1EV-03(A)-E	B1EP-03(A)-E		(1)
			5 m	B1EV-05(A)-E	B1EP-05(A)-E		
			10 m	B1EV-10(A)-E	B1EP-10(A)-E		
			15 m	B1EV-15(A)-E	B1EP-15(A)-E		
		3.0kW	3 m	B3EV-03(A)-E	B3EP-03(A)-E		
			5 m	B3EV-05(A)-E	B3EP-05(A)-E		
			10 m	B3EV-10(A)-E	B3EP-10(A)-E		
			15 m	B3EV-15(A)-E	B3EP-15(A)-E		
		4.0 to 7.0kW <sup>*4</sup>	3 m	B4EV-03(A)-E	B4EP-03(A)-E		
			5 m	B4EV-05(A)-E	B4EP-05(A)-E		
			10 m	B4EV-10(A)-E	B4EP-10(A)-E		
			15 m	B4EV-15(A)-E	B4EP-15(A)-E		
	Servomotor Power Cable (for Servomotor with Holding Brake) <sup>*3</sup>	1.0kW to 2.5kW	3 m	BABEV-03(A)-E	BABEP-03(A)-E		(5)
			5 m	BABEV-05(A)-E	BABEP-05(A)-E		
			10 m	BABEV-10(A)-E	BABEP-10(A)-E		
			15 m	BABEV-15(A)-E	BABEP-15(A)-E		
		3.0kW	3 m	BCBEV-03(A)-E	BCBEP-03(A)-E		
			5 m	BCBEV-05(A)-E	BCBEP-05(A)-E		
			10 m	BCBEV-10(A)-E	BCBEP-10(A)-E		
			15 m	BCBEV-15(A)-E	BCBEP-15(A)-E		
4.0 to 5.0kW <sup>*4</sup>		3 m	BDBEV-03(A)-E	BDBEP-03(A)-E			
		5 m	BDBEV-05(A)-E	BDBEP-05(A)-E			
		10 m	BDBEV-10(A)-E	BDBEP-10(A)-E			
		15 m	BDBEV-15(A)-E	BDBEP-15(A)-E			
Fan Cable	7.0kW	3 m	BFEV-03(A)-E	-		(4)	
		5 m	BFEV-05(A)-E	-			
		10 m	BFEV-10(A)-E	-			
		15 m	BFEV-15(A)-E	-			
		20 m	BFEV-20(A)-E	-			
400V	Servomotor Power Cable (for Servomotor with or without Holding Brake) <sup>*1</sup>	1.0kW to 2.5kW	3 m	B1EV-03(A)-E	B1EP-03(A)-E		(1)
			5 m	B1EV-05(A)-E	B1EP-05(A)-E		
			10 m	B1EV-10(A)-E	B1EP-10(A)-E		
			15 m	B1EV-15(A)-E	B1EP-15(A)-E		
		3.0 to 5.0kW	3 m	B3EV-03(A)-E	B3EP-03(A)-E		
			5 m	B3EV-05(A)-E	B3EP-05(A)-E		
			10 m	B3EV-10(A)-E	B3EP-10(A)-E		
			15 m	B3EV-15(A)-E	B3EP-15(A)-E		
	Holding Brake Cable	1kW to 5kW	3 m	BBEV-03(A)-E	-		(2)
			5 m	BBEV-05(A)-E	-		
			10 m	BBEV-10(A)-E	-		
			15 m	BBEV-15(A)-E	-		(3)
			20 m	BBEV-20(A)-E	-		
			3 m	-	BBEP-03(A)-E		
			5 m	-	BBEP-05(A)-E		
			10 m	-	BBEP-10(A)-E		
			15 m	-	BBEP-15(A)-E		

\*1 400V Servomotors with holding brakes require a holding brake cable in addition to a power cable.

\*2 Premium cables have a braided cable shield and are intended for use in applications that require CE. Premium cables have a continuous flex rating and are intended for use in movable sections such as robot arms.

\*3 200V servomotors with holding brakes use a combined power and brake cable

\*4 The 7.0kW, 200V servomotor requires a separate fan cable. 7.0kW units are not available with holding brake.

## Selecting Cables

### (1) Wiring Specifications for 200V and 400V Servomotors without Holding Brakes\*

#### ● Value Type

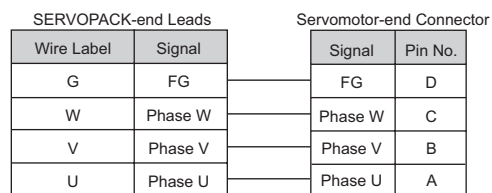

\*400V servomotors with holding brakes require a separate holding brake cable. See (2) and (3).

#### ● Premium Type

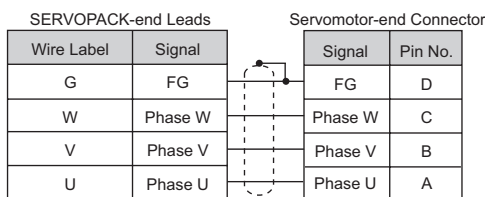

\*400V servomotors with holding brakes require a separate holding brake cable. See (2) and (3).

### (2) Wiring Specifications for the Value Type Brake Cable for 400V Servomotors

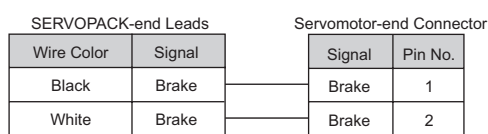

Note: No polarity for connection to a holding brake.

### (3) Wiring Specifications for the Premium Type Brake Cable for 400V Servomotors

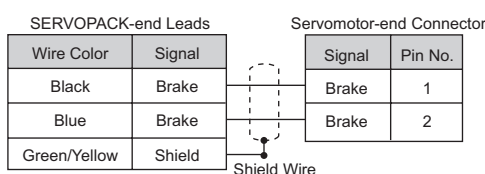

Note: No polarity for connection to a holding brake.

### (4) Wiring Specifications for the Fan on 200V 7.0kW Servomotors

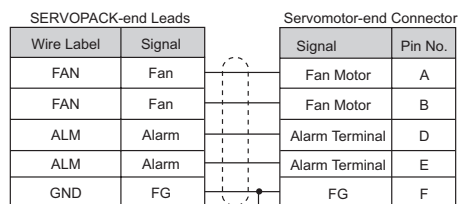

Notes:

No polarity for connection to a fan.

No polarity for connection to an alarm circuit.

### (5) Wiring Specifications for 200V Servomotors with Holding Brakes

#### ● Value Type

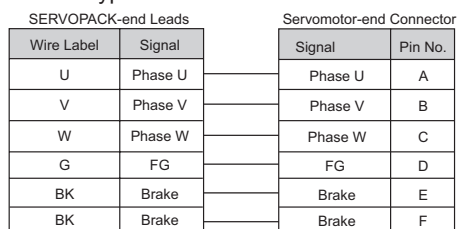

Note: No polarity for connection to a holding brake.

#### ● Premium Type

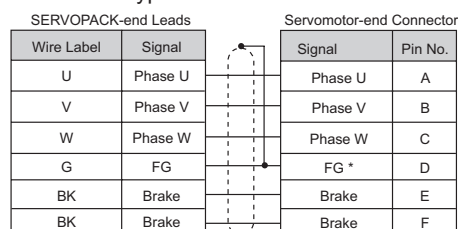

Note: No polarity for connection to a holding brake.

\* For 200V Premium Cable, shield is connected to FG wire on the servomotor-end of the cable.

## ● Customer Cable Assembly

Customers may assemble the servomotor's main circuit cables and attach connectors to connect the SERVOPACKS and the SGMSV servomotors.

The connectors for these models are round. The connectors specified by Yaskawa are required. Note that the connectors vary depending on the operation environment of servomotors.

Two types of connectors are available.

- Standard connectors
- Protective structure IP67 and European Safety Standards compliant connectors

Yaskawa does not specify which cables to use. Use appropriate cables for the connectors.

# Selecting Cables

## ● Standard Connectors

### ● Connector Configuration

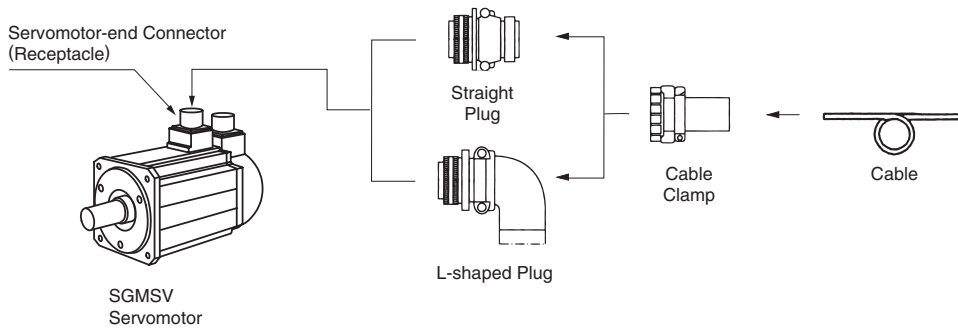

### (1) Without Holding Brakes

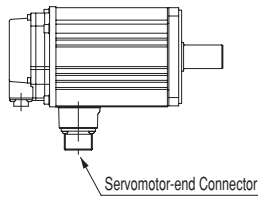

Servomotor-end Connector  
For 1.0 to 7.0 kW

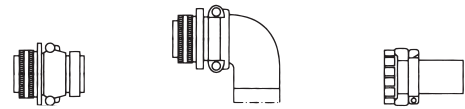

Capacity kW	Servomotor-end Connector (Receptacle)	Cable-end Connector (Not provided by Yaskawa)		
		Straight Plug	L-shaped Plug	Cable Clamp
1.0 to 2.5	MS3102A18-10P	MS3106B18-10S	MS3108B18-10S	MS3057-10A
3.0 to 7.0	MS3102A22-22P	MS3106B22-22S	MS3108B22-22S	MS3057-12A

Note: Servomotor-end connectors (receptacles) are RoHS-compliant. Contact the respective connector manufacturers for RoHS-compliant cable-end connectors.

### (2) With Holding Brakes (200 V)

No brake connector for 200-V models  
(there are brake terminals on the servomotor-end connectors).

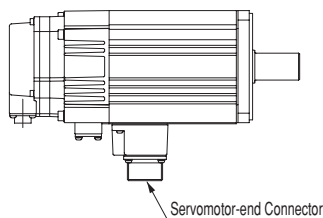

Servomotor-end Connector  
For 1.0 to 5.0 kW

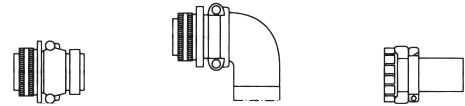

Capacity kW	Servomotor-end Connector (Receptacle)	Cable-end Connector (Not provided by Yaskawa)		
		Straight Plug	L-shaped Plug	Cable Clamp
1.0 to 2.5	MS3102A20-15P	MS3106B20-15S	MS3108B20-15S	MS3057-12A
3.0 to 5.0	MS3102A24-10P	MS3106B24-10S	MS3108B24-10S	MS3057-16A

Note: Servomotor-end connectors (receptacles) are RoHS-compliant. Contact the respective connector manufacturers for RoHS-compliant cable-end connectors.

## Selecting Cables

### (3) With Holding Brakes (400 V)

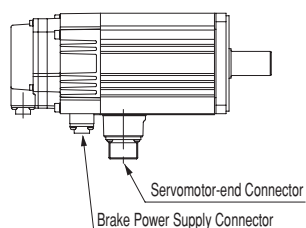

Servomotor-end Connector  
For 1.0 to 5.0 kW

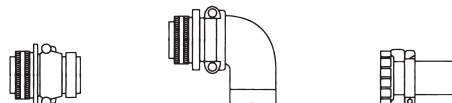

Capacity kW	Servomotor-end Connector (Receptacle)	Cable-end Connector (Not provided by Yaskawa)		
		Straight Plug	L-shaped Plug	Cable Clamp
1.0 to 2.5	MS3102A18-10P	MS3106B18-10S	MS3108B18-10S	MS3057-10A
3.0 to 5.0	MS3102A22-22P	MS3106B22-22S	MS3108B22-22S	MS3057-12A

Note: Servomotor-end connectors (receptacles) are RoHS-compliant. Contact the respective connector manufacturers for RoHS-compliant cable-end connectors.

Brake Power Supply Connector  
For 1.0 to 5.0 kW

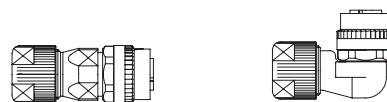

Capacity kW	Servomotor-end Connector (Receptacle)	Cable-end Connector (Not provided by Yaskawa)		
		Straight Plug	L-shaped Plug	Manufacturer
1.0 to 5.0	CM10-R2P-D	CM10-SP2S-S-D Applicable Cable: 4.0 dia. to 6.0 dia.	CM10-AP2S-S-D Applicable Cable: 4.0 dia. to 6.0 dia.	DDK Ltd.
		CM10-SP2S-M-D Applicable Cable: 6.0 dia. to 9.0 dia.	CM10-AP2S-M-D Applicable Cable: 6.0 dia. to 9.0 dia.	
		CM10-SP2S-L-D Applicable Cable: 9.0 dia. to 11.6 dia.	CM10-AP2S-L-D Applicable Cable: 9.0 dia. to 11.6 dia.	

To order a brake power supply connector kit (1.0 to 5.0 kW)  
with the order no. below, contact your Yaskawa representative.

J Z S P - C V B 9 - S M S 2 - E

Connector Type

S: Straight plug

A: L-shaped plug

Bush Size\*1

S: Size S (4.0 dia. to 6.0 dia.)

M: Size M (6.0 dia. to 9.0 dia.)

L: Size L (9.0 dia. to 11.6 dia.)

Contact Pin Size

S2: Soldered

C3: Crimping type\*2

\*1: A size-M connector kit is available as standard equipment.

\*2: A crimp tool (model: 357J-50448T) by DDK Ltd. is required.

## Selecting Cables Units: mm

### • Cable-end Connectors

#### (1) MS3106B□□-□□S : Straight Plug

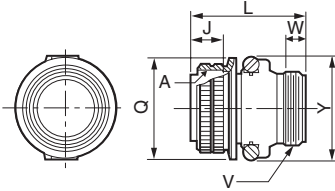

Shell Size	Joint Screw A	Length of Joint Portion J±0.12	Overall Length L max.	Outer Diameter of Joint Nut Q <sup>+0.10</sup> <sub>-0.38</sub>	Cable Clamp Set Screw V	Effective Screw Length W min.	Maximum Width Y max.
18	1-1/8-18UNEF	18.26	52.37	34.13	1-20UNEF	9.53	42
20	1-1/4-18UNEF	18.26	55.57	37.28	1-3/16-18UNEF	9.53	47
22	1-3/8-18UNEF	18.26	55.57	40.48	1-3/16-18UNEF	9.53	50
24	1-1/2-18UNEF	18.26	58.72	43.63	1-7/16-18UNEF	9.53	53

#### (2) MS3108B□□-□□S : L-shaped Plug

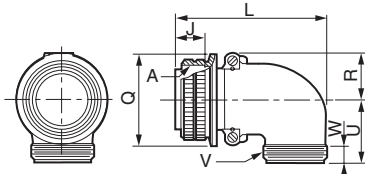

Shell Size	Joint Screw A	Length of Joint Portion J±0.12	Overall Length L max.	Outer Diameter of Joint Nut Q <sup>+0.10</sup> <sub>-0.38</sub>	R ±0.5	U ±0.5	Cable Clamp Set Screw V	Effective Screw Length W min.
18	1-1/8-18UNEF	18.26	68.27	34.13	20.5	30.2	1-20UNEF	9.53
20	1-1/4-18UNEF	18.26	76.98	37.28	22.5	33.3	1-3/16-18UNEF	9.53
22	1-3/8-18UNEF	18.26	76.98	40.48	24.1	33.3	1-3/16-18UNEF	9.53
24	1-1/2-18UNEF	18.26	86.51	43.63	25.6	36.5	1-7/16-18UNEF	9.53

#### (3) MS3057-□□A : Cable Clamp with Rubber Bushing

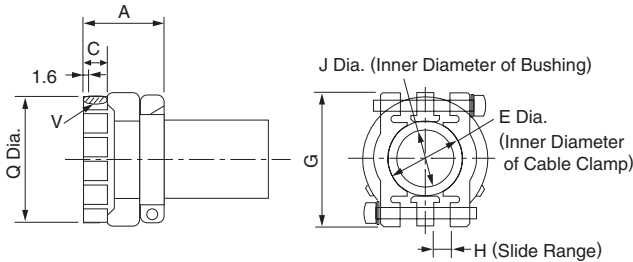

Cable Clamp Type	Applicable Connector Shell Size	Overall Length A±0.7	Effective Screw Length C	E Diameter	G±0.7	H	J Diameter	Set Screw V	Outer Diameter Q±0.7 Dia.	Attached Bushing
MS3057-10A	18	23.8	10.3	15.9	31.7	3.2	14.3	1-20UNEF	30.1	AN3420-10
MS3057-12A	20□22	23.8	10.3	19	37.3	4	15.9	1-3/16-18UNEF	35.0	AN3420-12
MS3057-16A	24	26.2	10.3	23.8	42.9	4.8	19.1	1-7/16-18UNEF	42.1	AN3420-16

### • Dimensional Drawings of Brake Power Supply

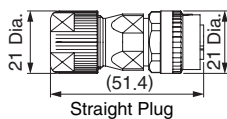
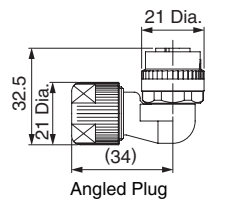

Items	Specifications
Connector Order No.	CM10-□P2S-□-D (Cables are not included.)
Protective Structure	IP67
Manufacturer	DDK Ltd.
Instructions	Angled plug (CM10-AP2S-□-D): TC-573, Straight plug (CM10-SP2S-□-D): TC-583
Electrical Contact Order No.	<p>Electrical contact (100 pcs in one bag)</p> <ul style="list-style-type: none"> <li>· Crimping type: CM10-#22SC(C3)-100, Wire size: AWG16 to 20, Outer diameter of sheath: 1.87 to 2.45 dia., Hand tool: 357J-50448T</li> <li>· Soldered type: CM10-#22SC (S2)-100, Wire size: AWG16 max.</li> </ul> <p>Real contact (4000 pcs on one reel)</p> <ul style="list-style-type: none"> <li>· Crimping type: CM10-#22SC(C3)-4000, Wire size: AWG 16 to 20, Outer diameter of sheath: 1.87 to 2.45 dia.,</li> </ul> <p>Semi-automatic tool: AP-A50541T (product name for one set), AP-A50541T-1 (product name for applicator)</p> <p>Note: The product name of the semi-automatic tool refers to the product name of the press and applicator (crimper) as a set.</p>

Selecting Cables

● Protective Structure IP67 and European Safety Standards Compliant Connector

● Connector Configuration

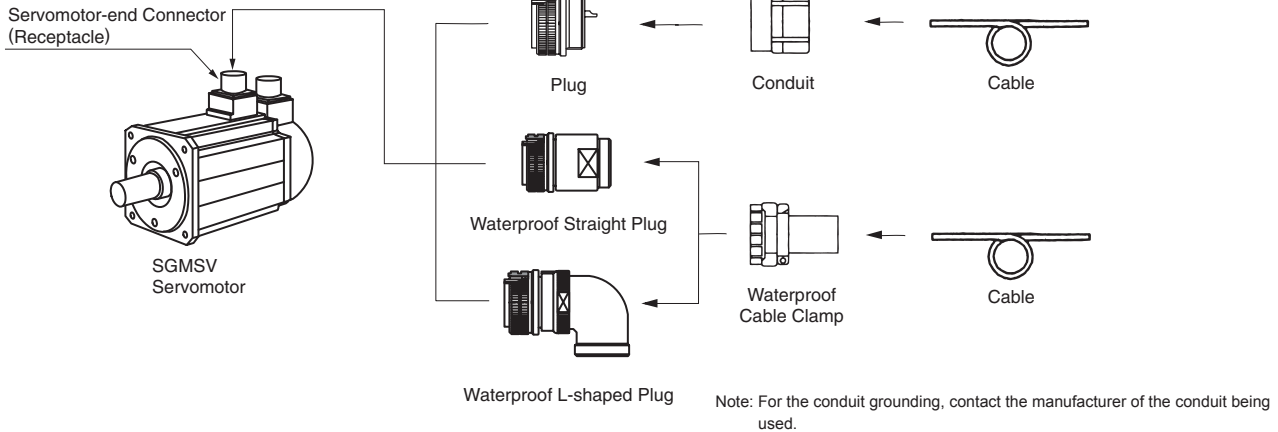

(1) Without Holding Brakes

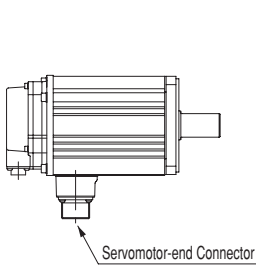

Servomotor-end Connector  
For 1.0 to 7.0 kW



Capacity kW	Servomotor-end Connector (Receptacle)	Cable-end Connector (Not Provided by Yaskawa)					Applicable Cable Diameter (For Reference)	Manufacturer
		Plug	Straight Plug	L-shaped Plug	Cable Clamp			
1.0 to 2.5	CE05-2A18- 10PD-D	CE05- 6A18- 10SD-D	CE05-6A18- 10SD-D-BSS	CE05-8A18- 10SD-D-BAS	CE3057-10A-1-D	10.5 dia. to 14.1 dia.	DDK Ltd.	
					CE3057-10A-2-D	8.5 dia. to 11.0 dia.		
					CE3057-10A-3-D	6.5 dia. to 8.7 dia.		
3.0 to 7.0	JL04HV-2E22- 22PE-B-R	JL04V- 6A22- 22SE-R	JL04V-6A22-22SE-EB-R or JA06A-22-22S-J1-EB-R*	JL04V-8A22-22SE-EB-R or JA08A-22-22S-J1-EB-R*	JL04-2022CK (09) -R	6.5 Dia. to 9.5 Dia.	Japan Aviation	
					JL04-2022CK (12) -R	9.5 Dia. to 13.0 Dia.	Electronics	
					JL04-2022CK (14) -R	12.9 Dia. to 15.9 Dia.	Industry, Ltd.	

\*: Not compliant with European Safety Standards, but compliant with protective structure IP67.

(2) With Holding Brakes (200 V)

No brake connector for 200-V models  
(there are brake terminals on the servomotor-end connectors).

Servomotor-end Connector  
For 1.0 to 5.0 kW

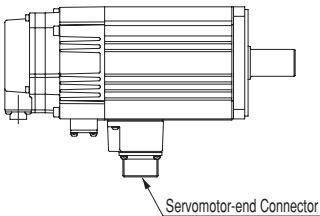
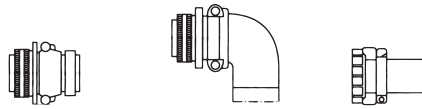

Capacity kW	Servomotor-end Connector (Receptacle)	Cable-end Connector (Not Provided by Yaskawa)					Applicable Cable Diameter (For Reference)	Manufacturer
		Plug	Straight Plug	L-shaped Plug	Cable Clamp			
1.0 to 2.5	JL04V-2E20- 15PE-B-R	JL04V- 6A20- 15SE-R	JL04V-6A20-15SE-EB-R	JL04V-8A20-15SE-EB-R	JL04-2022CK (09) -R	6.5 Dia. to 9.5 Dia.	Japan Aviation	
					JL04-2022CK (12) -R	9.5 Dia. to 13.0 Dia.		
					JL04-2022CK (14) -R	12.9 Dia. to 15.9 Dia.		
3.0 to 5.0	JL04V-2E24- 10PE-B-R	JL04- 6A24- 10SE-R	JL04V-6A24-10SE-EB-R or JA06A-24-10S-J1-EB-R*	JL04V-8A24-10SE-EB-R or JA08A-24-10S-J1-EB-R*	JL04-2428CK (11) -R	9.0 Dia. to 12.0 Dia.	Japan Aviation	
					JL04-2428CK (14) -R	12.0 Dia. to 15.0 Dia.		
					JL04-2428CK (17) -R	15.0 Dia. to 18.0 Dia.		
					JL04-2428CK (20) -R	18.0 Dia. to 20.0 Dia.		

\*: Not compliant with European Safety Standards, but compliant with protective structure IP67.

## Selecting Cables

### (3) With Holding Brakes (400 V)

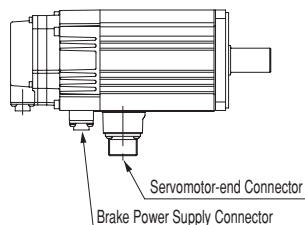

Servomotor-end Connector  
For 1.0 to 5.0 kW



Capacity kW	Servomotor-end Connector (Receptacle)	Cable-end Connector (Not Provided by Yaskawa)					Applicable Cable Diameter (For Reference)	Manufacturer
		Plug	Straight Plug	L-shaped Plug	Cable Clamp			
1.0 to 2.5	CE05-2A18- 10PD-D	CE05- 6A18- 10SD-D	CE05-6A18- 10SD-D-BSS	CE05-8A18- 10SD-D-BAS	CE3057-10A-1-D	10.5 dia. to 14.1 dia.	DDK Ltd.	
					CE3057-10A-2-D	8.5 dia. to 11.0 dia.		
					CE3057-10A-3-D	6.5 dia. to 8.7 dia.		
3.0 to 5.0	JL04HV-2E22- 22PE-B-R	JL04V- 6A22- 22SE-R	JL04V-6A22SE-EB-R or JA06A-22-22S-J1-EB-R*	JL04V-8A22-22SE-EB-R or JA08A-22-22S-J1-EB-R*	JL04-2022CK(09)-R	6.5 Dia. to 9.5 Dia.	Japan Aviation Electronics Industry, Ltd.	
					JL04-2022CK(12)-R	9.5 Dia. to 13.0 Dia.		
					JL04-2022CK(14)-R	12.9 Dia. to 15.9 Dia.		

\*: Not compliant with European Safety Standards, but compliant with protective structure IP67.

Brake Power Supply Connector  
For 1.0 to 5.0 kW



Capacity kW	Servomotor-end Connector (Receptacle)	Cable-end Connector (Not provided by Yaskawa)			Manufacturer
		Straight Plug	L-shaped Plug		
1.0 to 5.0	CM10-R2P-D	CM10-SP2S-S-D Applicable Cable: 4.0 dia. to 6.0 dia.	CM10-AP2S-S-D Applicable Cable: 4.0 dia. to 6.0 dia.	DDK Ltd.	
		CM10-SP2S-M-D Applicable Cable: 6.0 dia. to 9.0 dia.	CM10-AP2S-M-D Applicable Cable: 6.0 dia. to 9.0 dia.		
		CM10-SP2S-L-D Applicable Cable: 9.0 dia. to 11.6 dia.	CM10-AP2S-L-D Applicable Cable: 9.0 dia. to 11.6 dia.		

To order a brake power supply connector kit (1.0 to 5.0 kW)  
with the order no. below, contact your Yaskawa representative.

J Z S P - C V B 9 - S M S2 - E

Connector Type

S: Straight plug  
A: L-shaped plug

Bush Size\*1

S: Size S (4.0 dia. to 6.0 dia.)  
M: Size M (6.0 dia. to 9.0 dia.)  
L: Size L (9.0 dia. to 11.6 dia.)

Contact Pin Size

S2: Soldered  
C3: Crimping type\*2

\*1: A size-M connector kit is available as standard equipment.  
\*2: A crimp tool (model: 357J-50448T) by DDK Ltd. is required.

Selecting Cables

● Encoder Cables (Max. length: 20 m)

■ Non-Stock Items

Name	Length (L)	Order No.		Specifications	Details
		Standard Type	Flexible Type*		
Encoder Cable with Connectors (For Incremental Encoder)	3 m	JZSP-CVP01-03-E	JZSP-CVP11-03-E	<p>SERVOPACK End L Encoder End Connector (Crimped) (Molex Japan Co., Ltd.) CM10-SP10S-□-D (DDK Ltd.)</p>	(1)
	5 m	JZSP-CVP01-05-E	JZSP-CVP11-05-E		
	10 m	JZSP-CVP01-10-E	JZSP-CVP11-10-E		
	15 m	JZSP-CVP01-15-E	JZSP-CVP11-15-E		
	20 m	JZSP-CVP01-20-E	JZSP-CVP11-20-E		
	3 m	JZSP-CVP02-03-E	JZSP-CVP12-03-E		
	5 m	JZSP-CVP02-05-E	JZSP-CVP12-05-E		
	10 m	JZSP-CVP02-10-E	JZSP-CVP12-10-E		
Encoder Cable with Connectors (For Absolute Encoder, with a Battery Case)	15 m	JZSP-CVP02-15-E	JZSP-CVP12-15-E	<p>SERVOPACK End L Encoder End Connector (Crimped) (Molex Japan Co., Ltd.) CM10-AP10S-□-D (DDK Ltd.)</p>	(2)
	20 m	JZSP-CVP02-20-E	JZSP-CVP12-20-E		
	3 m	JZSP-CVP06-03-E	JZSP-CVP26-03-E		
	5 m	JZSP-CVP06-05-E	JZSP-CVP26-05-E		
	10 m	JZSP-CVP06-10-E	JZSP-CVP26-10-E		
	15 m	JZSP-CVP06-15-E	JZSP-CVP26-15-E		
	20 m	JZSP-CVP06-20-E	JZSP-CVP26-20-E		
	3 m	JZSP-CVP07-03-E	JZSP-CVP27-03-E		
5 m	JZSP-CVP07-05-E	JZSP-CVP27-05-E			
10 m	JZSP-CVP07-10-E	JZSP-CVP27-10-E			
15 m	JZSP-CVP07-15-E	JZSP-CVP27-15-E			
20 m	JZSP-CVP07-20-E	JZSP-CVP27-20-E			
SERVOPACK-end Connector Kit		JZSP-CMP9-1-E		Soldered  (Molex Japan Co., Ltd.)	(3)
Encoder-end Connectors for Protective Structure IP67 Straight Plug		JZSP-CVP9-1-E	Connector Specifications Plug: CM10-SP10S-M-D Electrical Contact: (Crimped)** CM10-#22SC(C4)-100 Applicable Cable Diameter: 6.0 dia. to 9.0 dia.	<p>+ Electrical Contact</p>	-
		JZSP-CVP9-3-E	Connector Specifications Plug: CM10-SP10S-M-D Electrical Contact: (Soldered) CM10-#22SC(S1)-100 Applicable Cable Diameter: 6.0 dia. to 9.0 dia		
Encoder-end Connectors for Protective Structure IP67 L-shaped Plug		JZSP-CVP9-2-E	Connector Specifications Plug: CM10-AP10S-M-D Electrical Contact: (Crimped)** CM10-#22SC(C4)-100 Applicable Cable Diameter: 6.0 dia. to 9.0 dia.	<p>+ Electrical Contact</p>	-
		JZSP-CVP9-4-E	Connector Specifications Plug: CM10-AP10S-M-D Electrical Contact: (Soldered) CM10-#22SC(S1)-100 Applicable Cable Diameter: 6.0 dia. to 9.0 dia		
Cables	3 m	JZSP-CMP09-03-E	JZSP-CSP39-03-E		(4)
	5 m	JZSP-CMP09-05-E	JZSP-CSP39-05-E		
	10 m	JZSP-CMP09-10-E	JZSP-CSP39-10-E		
	15 m	JZSP-CMP09-15-E	JZSP-CSP39-15-E		
	20 m	JZSP-CMP09-20-E	JZSP-CSP39-20-E		

\* Use flexible cables for movable sections such as robot arms.

\*\* A crimp tool (357J-52667T) is required



## Selecting Cables

### (1) Wiring Specifications for Cable with Connectors (For incremental encoder)

#### · Standard Type

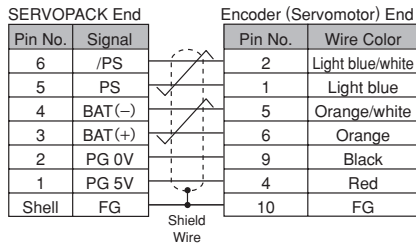

#### · Flexible Type

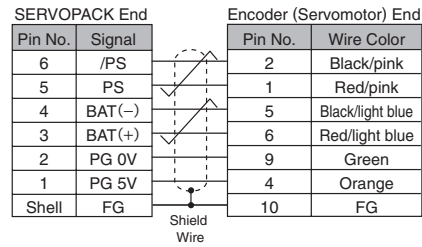

### (2) Wiring Specifications for Cable with Connectors (For absolute encoder, with a battery case)

#### · Standard Type

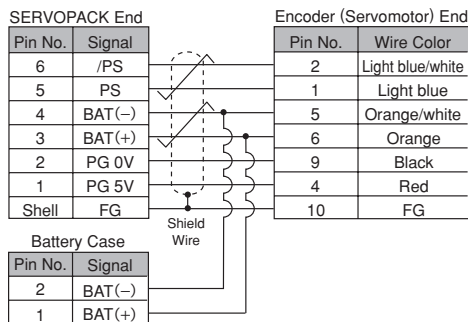

#### · Flexible Type

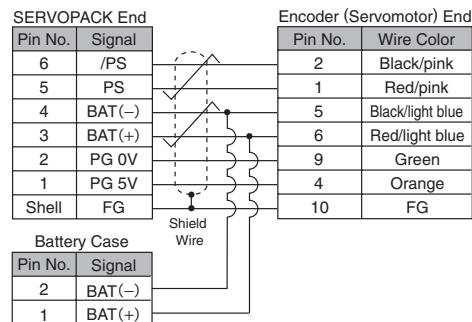

### (3) SERVOPACK-end Connector Kit Specifications

Items	Specifications
Order No.	JZSP-CMP9-1-E
Manufacturer	Molex Japan Co., Ltd.
Connector Model (For standard)	55100-0670 (soldered)
External Dimensions (Units: mm)	

Note: The mating connector model on SERVOPACK: 54280-800  
The mating connector model on servomotor: 55102-0600

### (4) Cable Specifications

Items	Standard Type	Flexible Type
Order No.*	JZSP-CMP09-□□-E	JZSP-CSP39-□□-E
Cable Length	20 m max.	
Specifications	UL20276 (Max. rating temperature: 80°C) AWG22×2C + AWG24×2P AWG22 (0.33 mm <sup>2</sup> ) Outer diameter of insulating sheath: 1.15 dia. AWG24 (0.20 mm <sup>2</sup> ) Outer diameter of insulating sheath: 1.09 dia.	UL20276 (Max. rating temperature: 80°C) AWG22×2C + AWG24×2P AWG22 (0.33 mm <sup>2</sup> ) Outer diameter of insulating sheath: 1.35 dia. AWG24 (0.20 mm <sup>2</sup> ) Outer diameter of insulating sheath: 1.21 dia.
Finished Dimensions	6.5 dia.	6.8 dia.
Internal Configuration and Lead Color		
Yaskawa Standards Specifications (Standard Length)	Cable length: 5 m, 10 m, 15 m, 20 m	

\*: Specify the cable length in □□ of order no.  
Example: JZSP-CMP09-05-E (5 m)

## Selecting Cables

### Encoder Cables (For extending from 30 to 50 m)

■ Limited Stock Items

Name	Length	Order No.	Specifications	Details
① Encoder-end Cables (For incremental and absolute encoder)	0.3 m	JZSP-CVP01-E		(1)
		JZSP-CVP02-E		
② Cable with Connectors (For incremental and absolute encoder)	30 m	JZSP-UCMP00-30-E		(2)
	40 m	JZSP-UCMP00-40-E		
	50 m	JZSP-UCMP00-50-E		
③ Cable with a Battery Case (For absolute encoder)	0.3 m	JZSP-CSP12-E*		(3)
④ Relay Cables	30 m	JZSP-CMP19-30-E		(4)
	40 m	JZSP-CMP19-40-E		
	50 m	JZSP-CMP19-50-E		

\*: When using an incremental encoder or using an absolute encoder with a battery connected to the host controller, no battery case is required.

#### (1) Wiring Specifications for Encoder-end Cable (For incremental and absolute encoder)

SERVOPACK End		Encoder (Servomotor) End	
Pin No.	Signal	Pin No.	Wire Color
6	/PS	2	Light blue/white
5	PS	1	Light blue
4	BAT (-)	5	Orange/white
3	BAT (+)	6	Orange
2	PG 0V	9	Black
1	PG 5V	4	Red
Shell	FG	10	FG

Shield Wire

Note: The signals BAT(+) and BAT(-) are used when using an absolute encoder.

#### (2) Wiring Specifications for Cable with Connectors (For incremental and absolute encoder)

SERVOPACK End		Encoder (Servomotor) End	
Pin No.	Signal	Pin No.	Wire Color
6	/PS	6	Light blue/white
5	PS	5	Light blue
4	BAT (-)	4	Orange/white
3	BAT (+)	3	Orange
2	PG 0V	2	Black
1	PG 5V	1	Red
Shell	FG	Shell	FG

Shield Wire

#### (4) Relay Encoder Cable Specifications

Item	Standard Type
Order No.*	JZSP-CMP19-□□-E
Cable Length	50 m max.
Specifications	UL20276 (Max. rating temperature: 80°C) AWG16×2C+AWG26×2P AWG16 (1.31 mm <sup>2</sup> ) Outer diameter of insulating sheath: 2.0 dia. mm AWG26 (0.13 mm <sup>2</sup> ) Outer diameter of insulating sheath: 0.91 dia. mm
Finished Dimensions	6.8 dia.
Internal Configuration and Lead Colors	
Yaskawa Standard Specifications (Standard Length)	Cable length: 30 m, 40 m, 50 m

\*: Specify the cable length in □□ of order no.  
Example: JZSP-CMP19-30-E (30 m)

#### (3) Wiring Specifications for Cable with a Battery Case (For absolute encoder)

SERVOPACK End		Encoder (Servomotor) End	
Pin No.	Signal	Pin No.	Wire Color
6	/PS	6	Light blue/white
5	PS	5	Light blue
4	BAT (-)	4	Orange/white
3	BAT (+)	3	Orange
2	PG 0V	2	Black
1	PG 5V	1	Red
Shell	FG	Shell	FG

Shield Wire

Battery Case	
Pin No.	Signal
2	BAT (-)
1	BAT (+)



# Rotary Servomotor General Instructions

## Precautions on Servomotor Installation

Servomotors can be installed either horizontally or vertically.

The service life of the servomotor will be shortened or unexpected problems will occur if the servomotor is installed incorrectly or in an inappropriate location. Always observe the following installation instructions.

**CAUTION**

Do not connect the servomotor directly to a commercial power line. This will damage the servomotor. The servomotor cannot operate without the proper SERVOPACK.

### (1) Installation Environment

Items	Condition
Ambient Temperature	0 to 40°C (no freezing)
Ambient Humidity	20% to 80%RH (no condensation)
Installation Site	<ul style="list-style-type: none"> <li>· Free of corrosive or explosive gases.</li> <li>· Well-ventilated and free of dust and moisture.</li> <li>· Facilitates inspection and cleaning.</li> <li>· Elevation :1,000 m max.</li> <li>· Free of high magnetic field</li> </ul>
Storage Environment	Store the servomotor in the following environment if it is stored with the power cable disconnected. Ambient temperature during storage: -20 to +60°C (no freezing) Ambient humidity during storage: 20% to 80%RH (no condensation)

### (2) Enclosure

The servomotor enclosure\* is described table as follows.

Model	Without Gears	With Gears
SGMAV□SGMJV	IP65	IP55
SGMPS	IP55 IP67 (optional)	IP55
SGMGV	IP67	-
SGMSV	IP67 (SGMSV-70 servomotor only: IP22)	-

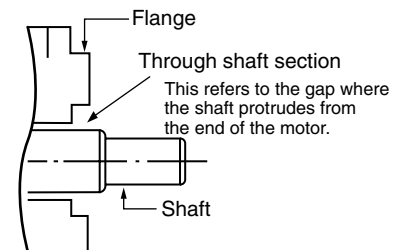

\*: Except through shaft section. The enclosure specification can be satisfied only when using a specified cable.

- Do not use servomotors in a location that is subject to oil. If the servomotor is used in a location that is subject to water or oil mist, order a servomotor with an oil seal to seal the through shaft section.

Precautions on Using Servomotor with Oil Seal:

- Put the oil surface under the oil seal lip.
- Use an oil seal in favorably lubricated condition.
- When using a servomotor with its shaft upward direction, be sure that oil will not stay in the oil seal lips.

### (3) Orientation

- Servomotors can be installed either horizontally or vertically. When installing servomotors vertically, make cable traps to keep out water. When mounting servomotors with the shaft up, take measures with the connected machine to prevent oil from getting into the servomotors through gear boxes etc.

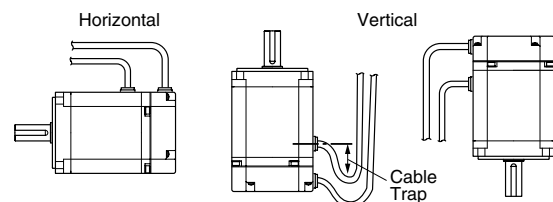

## (4) Alignment

Align the shaft of the servomotor with the shaft of the equipment, and then couple the shafts.

**IMPORTANT**

- 1 Install the servomotor so that alignment accuracy falls within the following range.

Vibration that will damage the bearings and encoders if the shafts are not properly aligned.

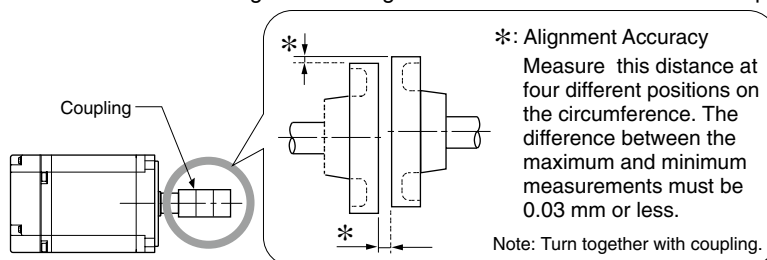

- 2 Do not allow any direct impact to the shafts when installing the couplings. Do not hit the area near encoders with a hammer etc., as impacts may damage the encoders.

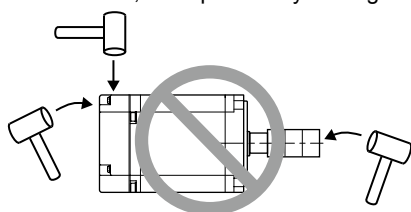

- 3 Before installation, thoroughly remove the anticorrosive paint from the end of the motor shaft. Only after removing the paint can servomotors be installed on the machines.

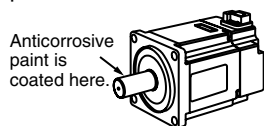

## (5) Cable Stress

- Make sure there is no bending or tension on the cables themselves, the connections, or the cable lead inlets.

Be especially careful to wire encoder cables so that they are not subject to stress because the core wires of encoder cables and main circuit cables are very thin at only 0.2 to 0.3 mm<sup>2</sup>.

## (6) Connectors

Observe the following precautions:

- When the connectors are connected to the motor, be sure to connect the end of motor main circuit cables before connecting the encoder cable's end.  
If the encoder cable's end is connected, the encoder may break because of the voltage differences between FG.
- Make sure there is no foreign matters such as dust and metal chips in the connector before connecting.
- Do not apply shock to resin connectors. Otherwise, they may be damaged.
- Make sure of the pin arrangement.
- Be sure not to apply stress on the connector, when using flexible cables. The connector may be damaged by stress.
- When handling a servomotor with its cables connected, hold the servomotor or the connectors and cables will be damaged.
- Fix the cable connector to SGMJV, SGMAV, SGMP5-01/-02/-04 or SGMGV-03/-05 servomotors with screws. Refer to "Cable connections to SGMJV, SGMAV and SGMP5 servomotors" or "Cable connections to SGMGV-03/-05 servomotors." Make sure that the connector is securely fixed with screws.
- If connectors are not connected properly, the protective structure specifications may not be satisfied.

## Cable Connections to SGMJV, SGMJV and SGMP5 Servomotors

Connect the main circuit cable and encoder cable to SGMJV, SGMJV or SGMP5-01/-02/-04 servomotor in the following manner.



Do not directly touch the connector pins provided with the servomotor. Particularly, the encoder may be damaged by static electricity, etc.

**STEP1** Remove the protective tape and cap from the servomotor connector.

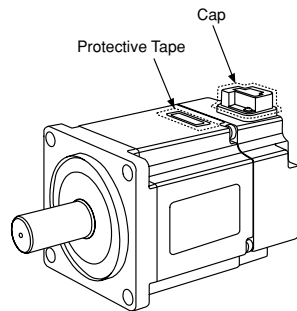

**STEP2** Mount the cable connector on the servomotor and fix it with screws as shown in the figure below.

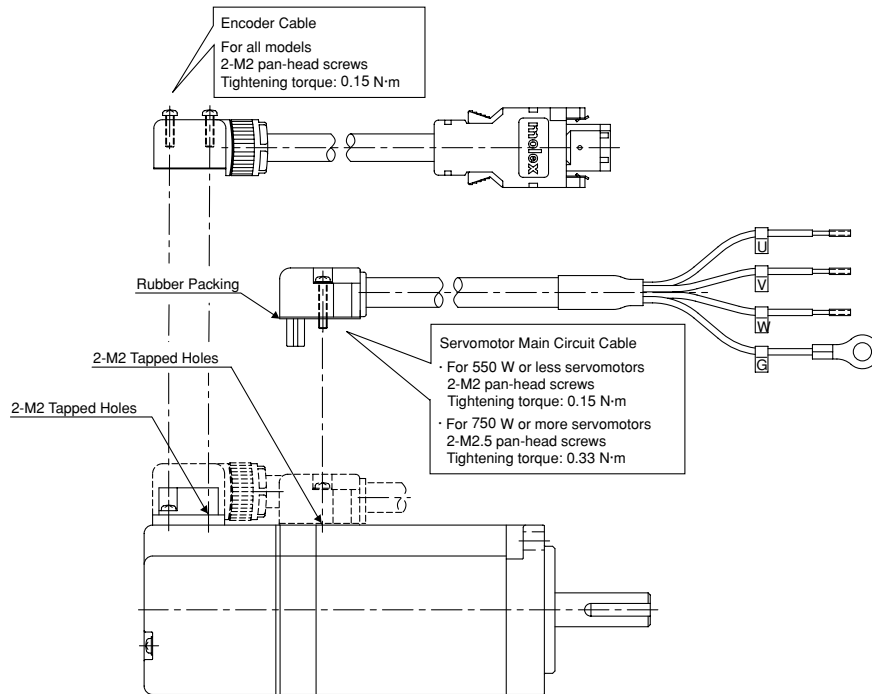

### IMPORTANT

- First, connect the servomotor to the servomotor main circuit cable end.
- Do not remove the rubber packing. Mount the connector so that the rubber packing is seated properly.  
If the rubber packing is not seated properly, the requirements for the protective structure specifications may not be met.

## Cable Connections to SGMGV-03/-05 Servomotors

Connect the main circuit cable and encoder cable to SGMGV-03/-05 servomotor in the following manner.

### ! CAUTION

Do not directly touch the connector pins provided with the servomotor. Particularly, the encoder may be damaged by static electricity, etc.

**STEP1** Remove the protective cap from the servomotor connector.

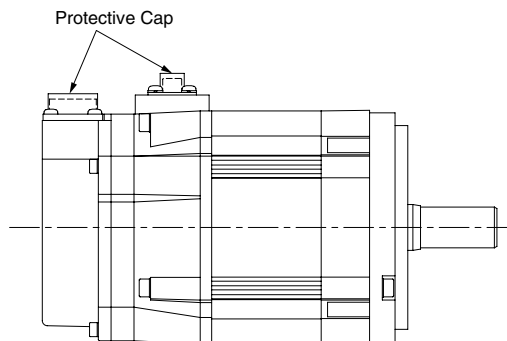

**STEP2** Mount the cable connector on the servomotor and fix it with screws as shown in the figure below.

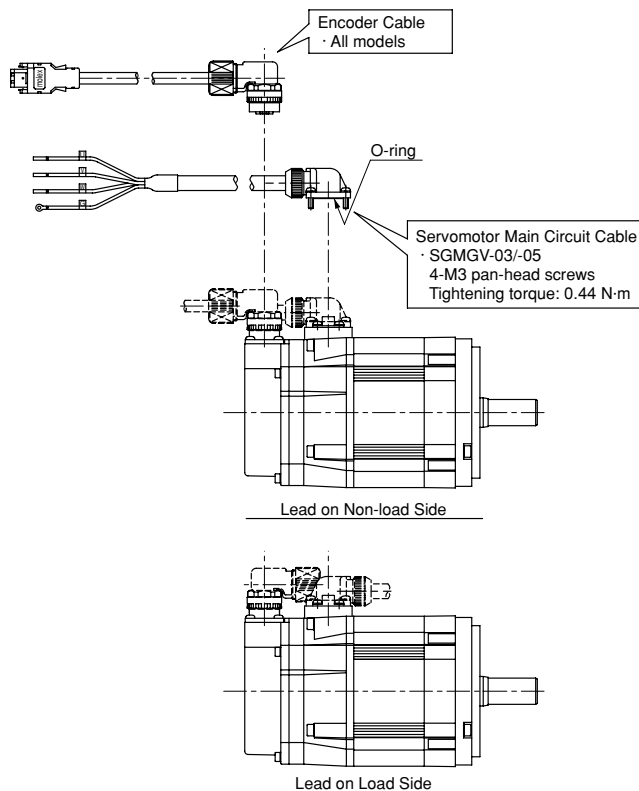

### IMPORTANT

- First, connect the servomotor to the servomotor main circuit cable end.
- Do not remove the O-ring. Mount the connector so that the O-ring is seated properly. If the O-ring is not seated properly, the requirements for the protective structure specifications may not be met.

## Mechanical Specifications

### ● Mechanical Tolerance(T.I.R. : Total Indicator Reading)

The following figure shows tolerances for the servomotor's output shaft and installation area. For more details on tolerances, refer to the external dimensions of the individual servomotor.

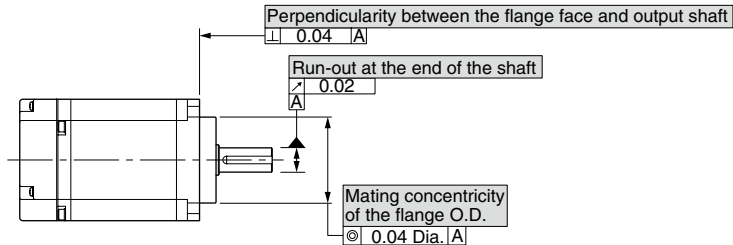

### ● Direction of Servomotor Rotation

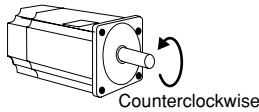

Positive rotation of the servomotor without a gear is counterclockwise when viewed from the load. Refer to Ratings and Specifications for each series regarding rotation direction of the servomotor with a gear. The direction of rotation can be reversed by changing the SERVOPACK parameters.

### ● Shock Resistance

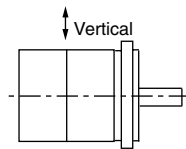

Impact Applied to the Servomotor

Mount the servomotor with the axis horizontal. The servomotor will withstand the following vertical impacts:

- Impact Acceleration: 490 m/s<sup>2</sup>
- Impact occurrences: 2

### ● Vibration Resistance

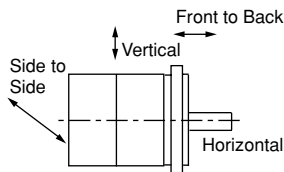

Impact Applied to the Servomotor

Mount the servomotor with the axis horizontal. The servomotor will withstand the following vibration acceleration in three directions: Vertical, side to side, and front to back.

Servomotor Model	Vibration Acceleration at Flange
SGMJV, SGMAV, SGMPS	49 m/s <sup>2</sup>
SGMGV -03 to -44, SGMSV -10 to -50	49 m/s <sup>2</sup> (Front to back direction: 24.5 m/s <sup>2</sup> )
SGMGV -55 to -1E	24.5 m/s <sup>2</sup>
SGMSV -70	14.7 m/s <sup>2</sup>

**IMPORTANT**

The amount of vibration the servomotor endures will vary depending on the application. Check the vibration acceleration being applied to your servomotor for each application.

### ● Vibration Class

The vibration class for the servomotors at rated motor speed is V15.

(A vibration class of V15 indicates a total vibration amplitude of 15 μm maximum on the servomotor during rated rotation.)

## Rotor Moment of Inertia

Small-capacity servomotors come in a medium inertia series "SGMJV servomotor," "SGMPS servomotor" and low inertia series "SGMAV servomotor." The rotor moment of inertia of SGMJV servomotor and SGMPS servomotor are twice as large as that of SGMAV. Select servomotors based on the specifications of your devices, such as load moment of inertia or machine rigidity.

- When the rotor moment of inertia is large:  
Servomotors are capable of corresponding load changes. This has the benefit of reducing settling time and speed ripple. This should also improve control stability of machines with low rigidity.
- When mounting the servomotor with low rotor moment of inertia to devices with load moment of inertia:  
Acceleration/deceleration torque increases and effective load ratio increases. Check the effective load ratio when you select motor capacity.

## Servomotor Heating Conditions

The motor rated specifications are continuous allowable values at an ambient temperature of 40°C when servomotors are installed with heat sinks. When the motor is mounted on a small surface, the motor temperature may rise considerably because of the limited heat radiating abilities of the surface. See the following graph for the relation between heat sink size and derating (derating ratio).

**IMPORTANT** The actual temperature rise depends on how the heat sink (servomotor mounting section) is fixed on the installation surface, what material is used for the motor mounting section, and motor speed. Always check the actual motor temperature.

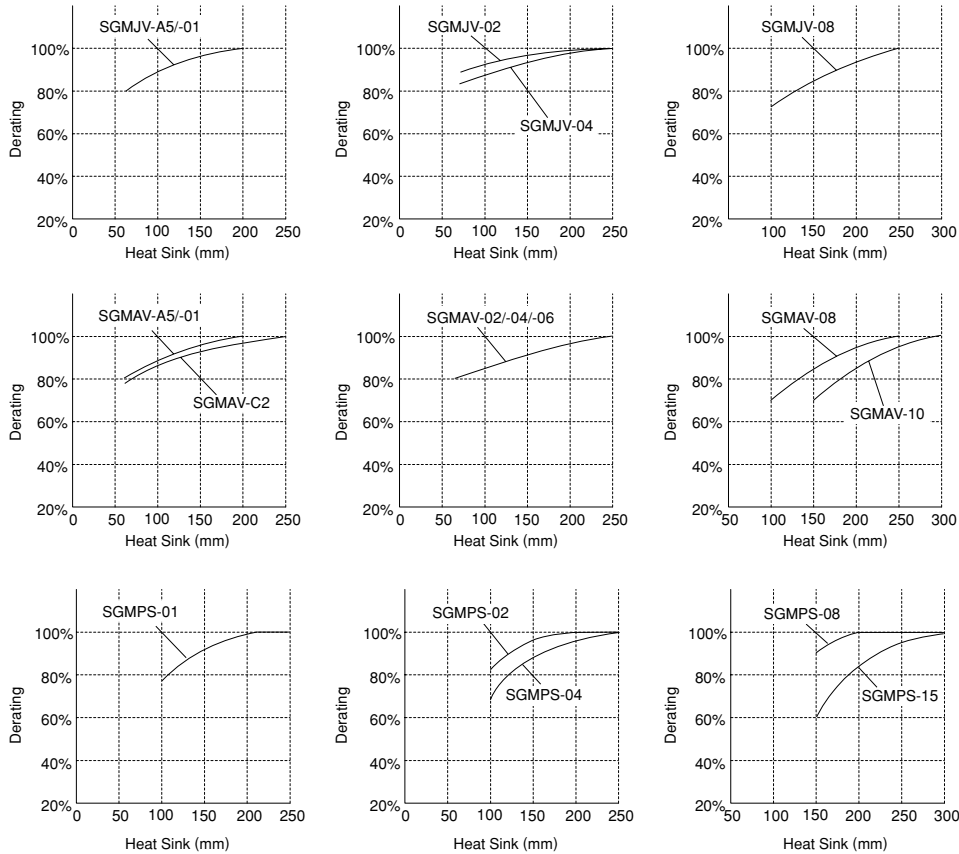

## Holding Brake Delay Time

Holding brakes have motion delay time that varies depending on when the brake is open and when the brake is operating. The following table shows the brake delay time of each servomotor.

**IMPORTANT** Make sure the holding brake delay time is correct for your servomotor.

- Example, switching the holding brakes on the DC side

Model	Voltage	Brake Open Time ms	Brake Operation Time ms	Model	Voltage	Brake Open Time ms	Brake Operation Time ms
SGMAV-A5 to -04	24 V	60	100	SGMGV-03 to -20	24 V, 90 V	100	80
SGMAV-06 to -10		80	100	SGMGV-30,-44		170	100 (24 V), 80 (90 V)
SGMJV-A5 to -04	24 V	60	100	SGMGV-55,-75,-1A		170	80
SGMJV-08		80	100	SGMGV-1E		250	80
SGMPS-01, -08	24 V	20	100	SGMSV-10 to -25		170	80
SGMPS-02, -04, -15		40	100	SGMSV-30 to -50		100	80

Rotary Servomotor General Instructions



## Rotary Cables with Model Numbers Beginning with "JZSP"

### ● Standard Cables

Standard servomotor main circuit cables, encoder cables, and relay cables cannot be used in cases where high flexibility is needed, as when the cables themselves move or are twisted or turned.

Recommended minimum bend radius of standard cables: 15 mm to cable center. Use flexible cables for flexible applications.

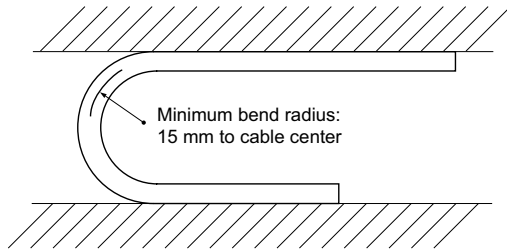

### ● Flexible Cables

#### (1) Life of Flexible Cable

The flexible cable supports 10,000,000 or more operations of bending life with the recommended bending radius  $R = 90$  mm under the following test conditions.

##### ● Conditions

- 1 Repeat moving one end of the cable forward and backward for 320 mm using the test equipment shown in the following figure.
- 2 Connect the lead wires in parallel, and count the number of cable return motion times until a lead wire is disconnected. Note that one reciprocation is counted as one test.

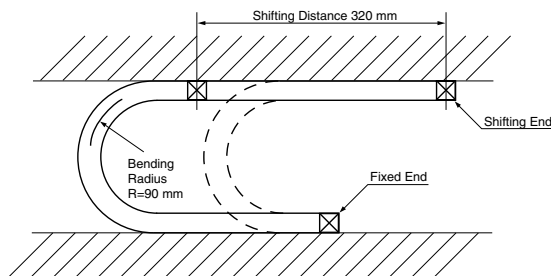

- Notes:
- 1 The life of flexible cable differs largely depending on the amount of mechanical shocks, mounting to the cable, and fixing methods. The life of flexible cable is limited under the specified conditions.
  - 2 The life of flexible cable indicates the number of bending times in which lead wires are electrically conducted and by which no cracks and damages that affects the performance of cable sheathing are caused. Disconnecting the shield wire is not taken into account.

#### (2) Wiring Precautions

Even if the recommended bending radius  $R$  is followed in the mechanical design, incorrect wiring may cause the early disconnection. Observe the following precautions when wiring.

##### (a) Cable twisting

Straighten the flexible cables wiring.

Twisted cables cause the early disconnection. Check the indication on the cable surface to make sure that the cable is not twisted.

##### (b) Fixing method

Do not fix the moving points of the flexible cable, or stress on the fixed points may cause early disconnection. Fix the cable at the minimum number of points. Do not put stress on the servomotor-end and SERVOPACK-end connectors.

##### (c) Cable length

If the cable length is too long, it may result the cable sagging. If the cable length is too short, excessive tension on the fixed points will cause the early disconnection. Use a flexible cable with the optimum length.

##### (d) Interference between cables

Avoid interference between cables.

Interference limits the motion of flexible cable, which causes early disconnection. Keep enough distance between cables, or provide a partition when wiring.

## Rotary Cables with Model Numbers NOT Beginning with "JZSP"

### ● Standard Cables

Standard servomotor main circuit cables, encoder cables, and relay cables cannot be used in cases where high flexibility is needed, as when the cables themselves move or are twisted or turned. Use flexible cables for flexible applications.

For bend radius, refer to the following chart.

Model	B1EV	B2EV	B3EV	B4EV	B5EV	B6EV	B7EV	B6EP	B7EP	BABEV	BCBEV	BDBEV	BBEV	BFEV
Recommended Bend Radius (mm)	72	82		119.5	89.5	191.8	226.1	151.2	201.6	87.65	94.6	107.3	35.2	47.24
Outer Diameter (mm)	14.4	16.4		23.9	17.9	27.4	32.3	25.2	33.6	17.53	18.92	21.46	8.8	11.81

Note: All models in the chart refer to the first set of characters of the cable's model number.

### ● Flexible Cables

#### (1) Life of Flexible Cable

The flexible cable supports several million cycles or more of bending life with the recommended bending radius under the following test conditions.

##### ● Conditions

- 1 Repeat moving one end of the cable forward and backward for 500 mm using the test equipment shown in the following figure.
- 2 Connect the lead wires in parallel, and count the number of cable return motion times until a lead wire is disconnected. Note that one reciprocation is counted as one cycle.

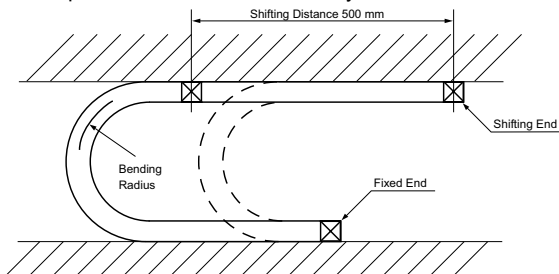

Notes: 1 The life of flexible cable differs largely depending on the amount of mechanical shocks, mounting to the cable, and fixing methods. The life of flexible cable is limited under the specified conditions.

2 The life of flexible cable indicates the number of bending times in which lead wires are electrically conducted and by which no cracks and damages that affect the performance of cable sheathing are caused. Disconnecting the shield wire is not taken into account.

#### (2) Specific Cable Details

The following chart contains details for each flexible cable with model not beginning with "JZSP"

Model	B1EP	B2EP	B3EP	B4EP	B5EP	BABEP	BCBEP	BDBEP	BBEP	YAI-CSM□□ (□□ = 21,22, 31, 32)	YAI-CSM□□ (□□ = 23,33)	YEA-CVM□□ (□□ = 21,41)
Recommended Bend Radius (mm)	140	165		224	191	180	177.1	190.3	50	90	90	94
Outer Diameter (mm)	14.0	16.5		22.4	19.1	15.0	16.1	17.3	7.7	7.0	8.0	9.4
Cycles (million)	8-20					9			10	10	10	10

Note: All models in the chart refer to the first set of characters of the cable's model number..

#### (3) Wiring Precautions

Even if the recommended bending radius is followed in the mechanical design, incorrect wiring may cause early disconnection. Observe the following precautions when wiring.

##### (a) Cable twisting

Straighten the flexible cables wiring.

Twisted cables cause early disconnection. Check the indication on the cable surface to make sure the cable is not twisted.

##### (b) Fixing method

Do not fix the moving points of the flexible cable, or stress on the fixed points may cause early disconnection. Fix the cable at the minimum number of points. Do not put stress on the servomotor-end and SERVOPACK-end connectors.

##### (c) Cable length

If the cable length is too long, it may result in the cable sagging. If the cable length is too short, excessive tension on the fixed points will cause early disconnection. Use a flexible cable with the optimum length.

##### (d) Interference between cables

Avoid interference between cables.

Interference limits the motion of flexible cable, which causes early disconnection. Keep enough distance between cables, or provide a partition when wiring.

## Battery Case

### ● Battery Case (Model: JUSP-BA01-E)

Use this battery case if your battery case needs replacing due to damage etc.. This battery case cannot be used with an incremental encoder cable.

#### IMPORTANT

- 1 The battery case (JUSP-BA01-E) is not provided with a battery. A battery must be purchased separately.
- 2 Install the battery case where the ambient temperature is between 0°C to 55°C.

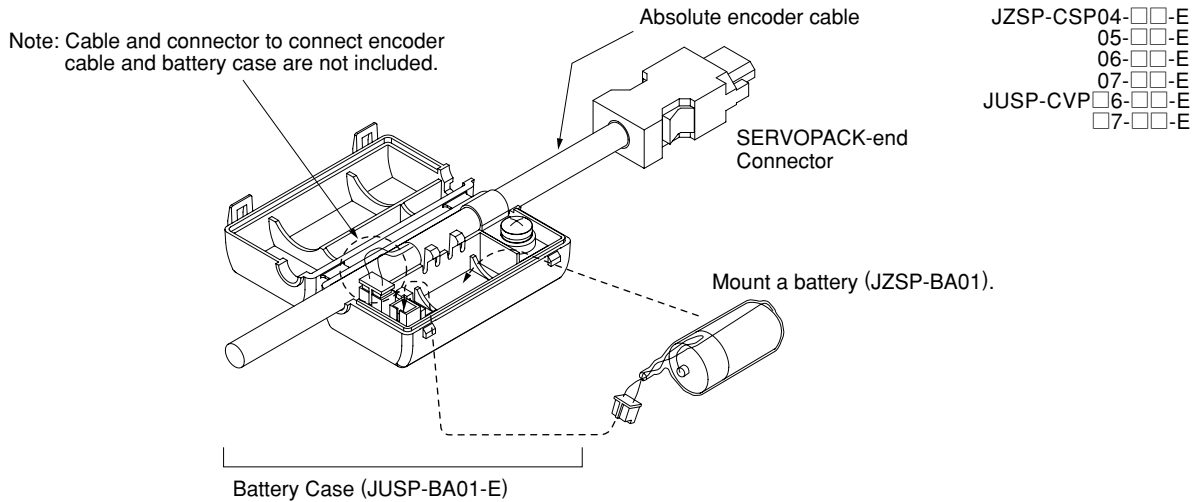

#### (1) Mounting a Battery in a Battery Case

Prepare a lithium battery (JZSP-BA01) and mount in a battery case.

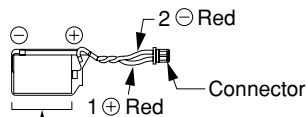

ER3 V Lithium Battery  
(3.6 V, 1000 mAh, manufactured by Toshiba Battery Co., Ltd.)

#### (2) Connecting a Battery to the Host Controller

Use a battery that meets the specifications of the host controller. Use an ER6VC3N (3.6 V, 2000 mAh, manufactured by Toshiba Battery Co., Ltd.) or equivalent battery.

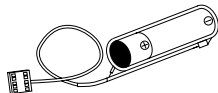

# General Instructions

# Direct Drive Servomotors

# SGMCS

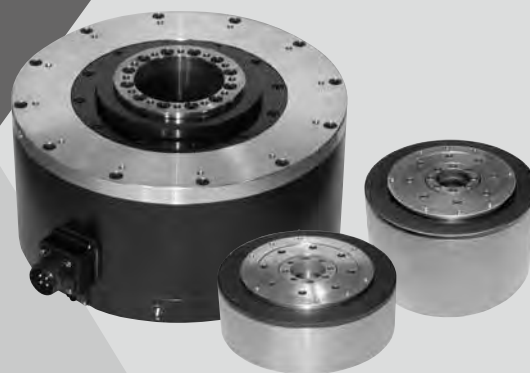

## Model Designations

SGMCS - 02 B 3 C 1 1

Direct Drive Servomotor SGMCS

1st+2nd digits 3rd digit 4th digit 5th digit 6th digit 7th digit

**1st+2nd digits** Rated Torque

● Small-capacity

Code	Specifications
02	2.0 N·m
04	4.0 N·m
05	5.0 N·m
07	7.0 N·m
08	8.0 N·m
10	10 N·m
14	14 N·m
16	16 N·m
17	17 N·m
25	25 N·m
35	35 N·m

● Medium-capacity

Code	Specifications
45	45 N·m
80	80 N·m
1A	110 N·m
1E	150 N·m
2Z	200 N·m

**3th digit** Motor Outer Diameter

Code	Specifications
B	135 dia. mm
C	175 dia. mm
D	230 dia. mm
E	290 dia. mm
M	280 dia. mm
N	360 dia. mm

**4th digit** Encoder Specifications

Code	Specifications
3	20-bit absolute (without multiturn data) (standard)
D	20-bit incremental (option)

**5th digit** Design Revision Order

Code	Specifications
A	Model of servomotor outer diameter code M, N
B	Model of servomotor outer diameter code E
C	Model of servomotor outer diameter code B, C, D

**6th digit** Flange Specifications

Code	Flange Specifications		Motor Outer Diameter Code (3rd digit)					
	Specifications	Mounted Side	B	C	D	E	M	N
1	C-face	Non-load side	○	○	○	○	-	-
		load end	-	-	-	-	○	○
3	C-face	Non-load side	-	-	-	-	○	○
4	C-face	Non-load side (with cable on side)	○	○	○	○	-	-

○ : Applicable Model

**7th digit** Option

Code	Specifications
1	Without options

NOTE: Shaded items are non-stock.

## Features

- Directly coupled to a load without a mechanical transmission such as a gear.
- Powerful and smooth operation throughout the speed range from low to high.  
(Instantaneous peak torque: 6 to 600 N·m maximum speed: 250 to 500 min<sup>-1</sup>)
- High-resolution, 20-bit encoder for highly precise indexing.
- Easy wiring and piping with the hollow structure.

## Application Examples

- Semiconductor equipment
- LCD manufacturing equipment
- Units for inspection and testing
- Electronic parts assembling machines
- IC handlers
- Inspection units for integrated circuits
- Automated machines
- Robots

## Rated Torque / Peak Torque

### ● Small-capacity



Outer Diameter 135 mm, Inner Diameter 20 mm

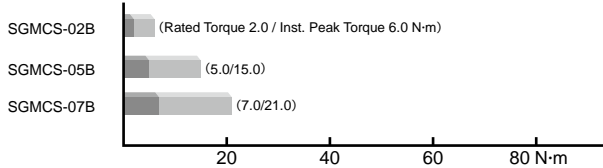

Outer Diameter 175 mm, Inner Diameter 35 mm

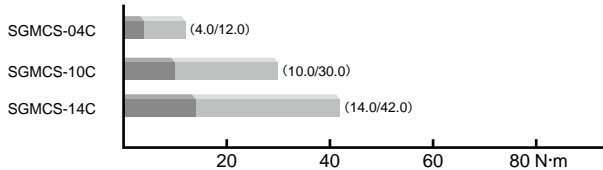

Outer Diameter 230 mm, Inner Diameter 60 mm

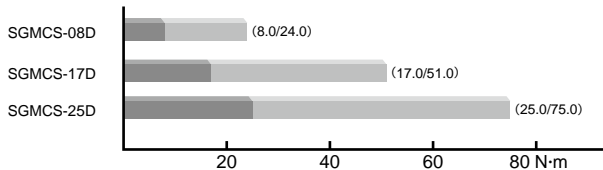

Outer Diameter 290 mm, Inner Diameter 75 mm

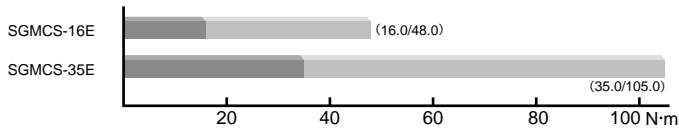

### ● Medium-capacity



Outer Diameter 280 mm, Inner Diameter 75 mm

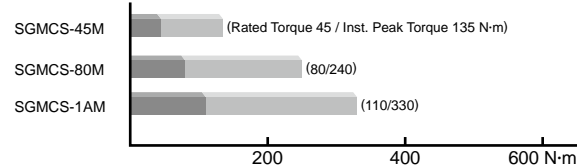

Outer Diameter 360 mm, Inner Diameter 118 mm

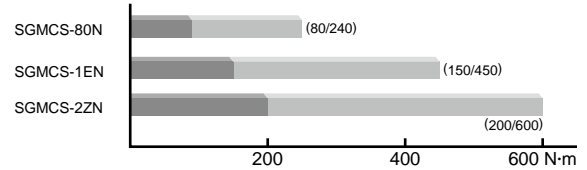

# Ratings and Specifications

## ● Small-capacity Series

Time Rating: Continuous

Vibration Class: V15

Insulation Resistance: 500 VDC, 10 M $\Omega$  min.

Ambient Temperature: 0 to 40°C

Excitation: Permanent magnet

Mounting: Flange method

Thermal Class: A

Withstand Voltage: 1500 VAC for one minute

Enclosure: Totally enclosed, self-cooled, IP42 (except for gaps on the rotating section of the shaft)

Ambient Humidity: 20% to 80% (no condensation)

Drive Method: Direct drive

Rotation Direction: Counterclockwise (CCW) with forward run reference when viewed from the load side

Voltage		200 V										
Servomotor Model SGMCS-□□□□□		02B□C	05B□C	07B□C	04C□C	10C□C	14C□C	08D□C	17D□C	25D□C	16E□B	35E□B
Rated Output <sup>*1</sup>	W	42	105	147	84	209	293	168	356	393	335	550
Rated Torque <sup>*1, *2</sup>	N·m	2.0	5.0	7.0	4.0	10.0	14.0	8.0	17.0	25.0	16.0	35.0
Instantaneous Peak Torque <sup>*1</sup>	N·m	6.0	15.0	21.0	12.0	30.0	42.0	24.0	51.0	75.0	48.0	105
Stall Torque <sup>*1</sup>	N·m	2.05	5.15	7.32	4.09	10.1	14.2	8.23	17.4	25.4	16.5	35.6
Rated Current <sup>*1</sup>	A <sub>rms</sub>	1.8	1.7	1.4	2.2	2.2	2.8	1.9	2.5	2.6	3.3	3.5
Instantaneous Max. Current <sup>*1</sup>	A <sub>rms</sub>	5.4	5.1	4.1	7.0	7.0	8.3	5.6	7.5	8.0	9.4	10.0
Rated Speed <sup>*1</sup>	min <sup>-1</sup>	200			200			200		150	200	150
Max. Speed <sup>*1</sup>	min <sup>-1</sup>	500			500	400	300	500	350	250	500	250
Torque Constant	N·m/A <sub>rms</sub>	1.18	3.17	5.44	2.04	5.05	5.39	5.1	7.8	10.8	5.58	11.1
Rotor Moment of Inertia	×10 <sup>-4</sup> kg·m <sup>2</sup>	28	51	77	77	140	220	285	510	750	930	1430
Rated Power Rate <sup>*1</sup>	kW/s	1.4	4.9	6.4	2.1	7.1	8.9	2.2	5.7	8.3	2.75	8.57
Rated Angular Acceleration <sup>*1</sup>	rad/s <sup>2</sup>	710	980	910	520	710	640	280	330	330	170	240
Absolute Accuracy	arc-sec	±15			±15			±15		±15		
Repeatability	arc-sec	±1.3			±1.3			±1.3		±1.3		
Applicable SERVOPACK	SGDV-□□□□	2R8A, 2R1F			2R8A, 2R8F			2R8A, 2R8F		5R5A		

\*1: These items and torque-motor speed characteristics quoted in combination with an SGDV SERVOPACK are at an armature winding temperature of 100°C. Other values quoted at 20°C.

\*2: Rated torques are continuous allowable torque values at 40°C with a steel heat sink attached.

Heat sink: SGMCS-□□B : 350 mm × 350 mm × 12 mm SGMCS-□□C : 450 mm × 450 mm × 12 mm  
 SGMCS-□□D : 550 mm × 550 mm × 12 mm SGMCS-□□E : 650 mm × 650 mm × 12 mm

Notes: 1 SGMCS servomotor with holding brake is not available.

2 For the bearings used in SGMCS servomotors, loss varies according to the bearing temperature. At low temperatures, the amount of heat loss will be large.

## ● Small-capacity Series: Torque-Motor Speed Characteristics **A** : Continuous Duty Zone **B** : Intermittent Duty Zone<sup>(Note2)</sup>

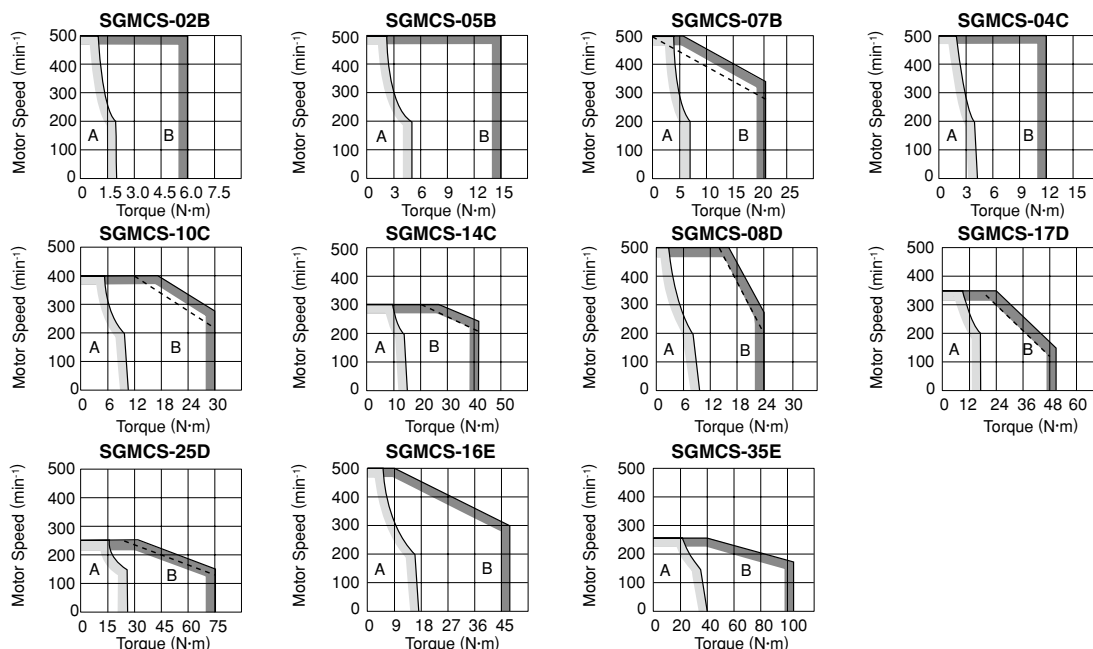

Notes: 1 The solid, dotted lines of the intermittent duty zone indicate the characteristics when a servomotor runs with the following combinations:

- The solid line: With a three-phase 200 V SERVOPACK
- The dotted line: With a single-phase 100 V SERVOPACK

2 When the effective torque during intermittent duty is within the rated torque, the servomotor can be used within the intermittent duty zone.

3 When the main circuit cable length exceeds 20 m, note that the intermittent duty zone of the Torque-Motor Speed Characteristics will shrink as the line-to-line voltage drops.

## Ratings and Specifications

### ● Medium-capacity Series

Time Rating: Continuous

Vibration Class: V15

Insulation Resistance: 500 VDC, 10 M $\Omega$  min.

Ambient Temperature: 0 to 40°C

Excitation: Permanent magnet

Mounting: Flange method

Thermal Class: F

Withstand Voltage: 1500 VAC for one minute

Enclosure: Totally enclosed, self-cooled, IP44

(except for shaft opening)

Ambient Humidity: 20% to 80% (no condensation)

Drive Method: Direct drive

Rotation Direction: Counterclockwise (CCW) with forward run reference when viewed from the load side

Voltage		200 V					
Servomotor Model SGMCS-□□□□□		45M□□	80M□□	1AM□□	80N□□	1EN□□	2ZN□□
Rated Output <sup>*1</sup>	W	707	1260	1730	1260	2360	3140
Rated Torque <sup>*1, *2</sup>	N·m	45	80	110	80	150	200
Instantaneous Peak Torque <sup>*1</sup>	N·m	135	240	330	240	450	600
Stall Torque <sup>*1</sup>	N·m	45	80	110	80	150	200
Rated Current <sup>*1</sup>	A <sub>rms</sub>	5.80	9.74	13.4	9.35	17.4	18.9
Instantaneous Max. Current <sup>*1</sup>	A <sub>rms</sub>	17	28	42	28	56	56
Rated Speed <sup>*1</sup>	min <sup>-1</sup>	150					
Max. Speed <sup>*1</sup>	min <sup>-1</sup>	300			250		
Torque Constant	N·m/A <sub>rms</sub>	8.39	8.91	8.45	9.08	9.05	11.5
Rotor Moment of Inertia	×10 <sup>-4</sup> kg·m <sup>2</sup>	388	627	865	1360	2470	3060
Rated Power Rate <sup>*1</sup>	kW/s	52.2	102	140	47.1	91.1	131
Rated Angular Acceleration <sup>*1</sup>	rad/s <sup>2</sup>	1160	1280	1270	588	607	654
Applicable SERVOPACK	SGDV-□□□□	7R6A	120A	180A	120A	200A	200A

\*1: These items and torque-motor speed characteristics quoted in combination with an SGDV SERVOPACK are at an armature winding temperature of 20°C.

\*2: Rated torques are continuous allowable torque values at 40°C with a steel heat sink attached.

Heat sink: 750 mm × 750 mm × 45 mm

Notes: 1 SGMCS servomotor with holding brake is not available.

2 For the bearings used in SGMCS servomotors, loss varies according to the bearing temperature. At low temperatures, the amount of heat loss will be large.

### ● Medium-capacity Series: Torque-Motor Speed Characteristics A : Continuous Duty Zone B : Intermittent Duty Zone<sup>(Note 1)</sup>

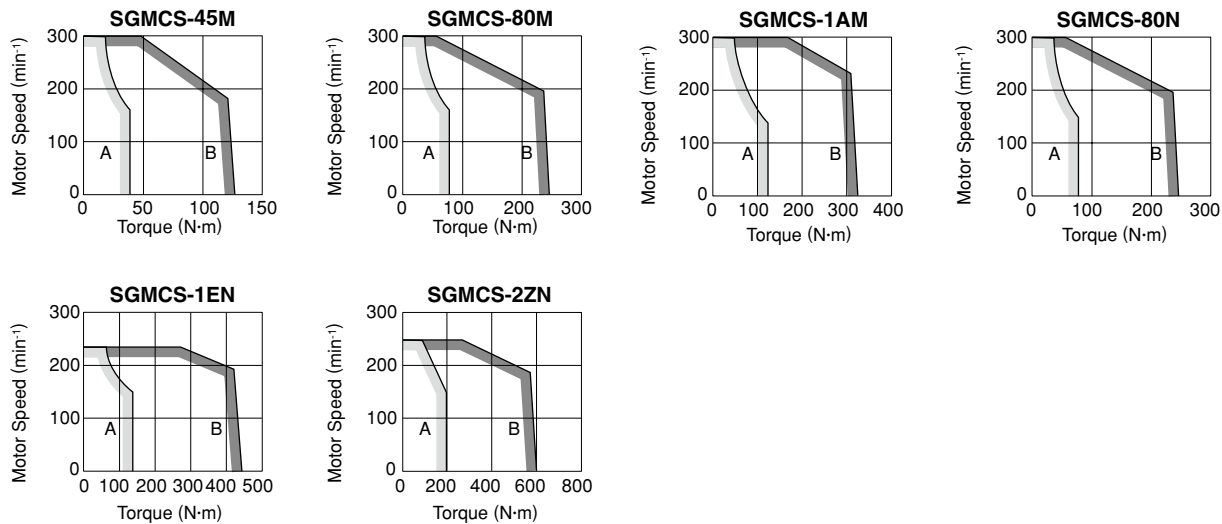

Notes: 1 When the effective torque during intermittent duty is within the rated torque, the servomotor can be used within the intermittent duty zone.

2 When the main circuit cable length exceeds 20 m, note that the intermittent duty zone of the Torque-Motor Speed Characteristics will shrink as the line-to-line voltage drops.



## Ratings and Specifications

### ● Allowable Load Moment of Inertia at the Motor Shaft

Servomotor Model		Rated Torque N·m	Allowable Load Moment of Inertia (Rotor Moment of Inertia Ratio)
SGMCS-	02B□C, 05B□C, 07B□C, 04C□C	2.0, 5.0, 7.0, 4.0	10 times
	10C□C	10.0	5 times
	14C□C, 08D□C, 17D□C, 25D□C, 16E□B, 35E□B	14.0, 8.0, 17.0, 25.0, 16.0, 35.0	3 times
	45M□A, 80M□A, 1AM□A, 80N□A, 1EN□A, 2ZN□A	45, 80, 110, 150, 200	3 times

### ● Load Moment of Inertia

The larger the load moment of inertia, the worse the movement response.

The allowable load moment of inertia ( $J_L$ ) depends on motor capacity, as shown above. This value is provided strictly as a guideline and results may vary depending on servomotor drive conditions.

Use the AC servo drive capacity selection program SigmaJunmaSize+ to check the operation conditions. The program can be downloaded for free from our web site (<http://www.e-mechatronics.com/>).

An overvoltage alarm (A.400) is likely to occur during deceleration if the load moment of inertia exceeds the allowable load moment of inertia. SERVOPACKs with a built-in regenerative resistor may generate a regenerative overload alarm (A.320). Take one of the following steps if this occurs.

- Reduce the torque limit.
- Reduce the deceleration rate.
- Reduce the maximum speed.
- Install an external regenerative resistor if the alarm cannot be cleared using the steps above. Refer to Regenerative Resistors on page 386.

**Mechanical Specifications**

● **Allowable Loads**

The loads applied while a servomotor is running are roughly classified in the following patterns. Design the machine so that the thrust load and moment load will not exceed the values in the table.

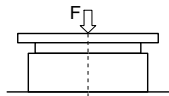

Where F is external force,  
Thrust load:  $F_a = F + \text{Load mass}$   
Moment load:  $M = 0$

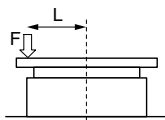

Where F is external force,  
Thrust load:  $F_a = F + \text{Load mass}$   
Moment load:  $M = F \times L$

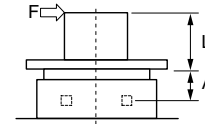

Where F is external force,  
Thrust load:  $F_a = \text{Load mass}$   
Moment load:  $M = F \times (L + A)$

(See the table below for the dimension A of each servomotor model.)

Servomotor Model SGMCS-□	02B	05B	07B	04C	10C	14C	08D	17D	25D	16E	35E	45M	80M	1AM	80N	1EN	2ZN
Dimension A mm	0			0			0			0			33		37.5		
Allowable Thrust Load (Fa) N	1500			3300			4000			11000			9000		16000		
Allowable Moment Load (M) N·m	40	50	64	70	75	90	93	103	135	250	320	180		350			

Note: SGMCS-02B to -35E servomotors, set dimensions A to 0 (zero).

● **Mechanical Tolerance**

The following table shows tolerances for the servomotor's output shaft and installation area. See the dimensional drawing of the individual servomotor for more details on tolerances.

(1) Small-capacity Series

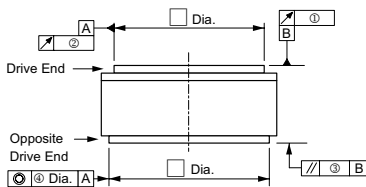

Tolerance T.I.R. (Total Indicator Reading) Units: mm	Servomotor Model SGMCS-										
	02B	05B	07B	04C	10C	14C	08D	17D	25D	16E	35E
① Run-out of the Surface of the Shaft	0.02		0.02		0.02		0.02		0.02		0.02
② Run-out at the End of the Shaft	0.04		0.04		0.04		0.04		0.04		0.04
③ Parallelism between the Flange Face and Output Shaft	0.07		0.07		0.07		0.08		0.08		0.08
④ Coaxiality of Output Axis and Mounting Socket Joint	0.07		0.07		0.07		0.08		0.08		0.08

(2) Medium-capacity Series

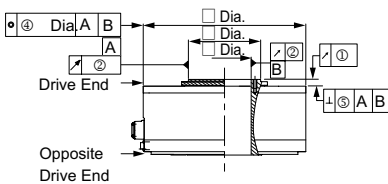

Tolerance T.I.R. (Total Indicator Reading) Units: mm	Servomotor Model SGMCS-					
	45M	80M	1AM	80N	1EN	2ZN
① Run-out of the Surface of the Shaft	0.02		0.02			
② Run-out at the End of the Shaft	0.04		0.04			
③ Parallelism between the Flange Face and Output Shaft*	-		-			
④ Coaxiality of Output Axis and Mounting Socket Joint	0.08		0.08			
⑤ Right angle between Flange Face and Output Shaft	0.08		0.08			

\* This tolerance is specified for certain models. See the dimensional drawing of the individual servo motor for details

● **Direction of Rotation**

Positive rotation of the servomotor is counterclockwise when viewed from the load.

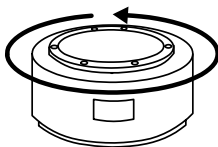

● **Impact Resistance**

Mount the servomotor with the axis horizontal. The servomotor will withstand the following vertical impacts:

- Impact Acceleration: 490 m/s<sup>2</sup>
- Number of Impacts: 2

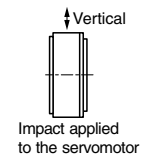

● **Vibration Resistance**

Mount the servomotor with the axis horizontal. The servomotor will withstand the following vibration acceleration in three directions: Vertical, side to side, and front to back.

Servomotor Type	Vibration Acceleration at Flange
Small-capacity Series	49 m/s <sup>2</sup>
Medium-capacity Series	24.5 m/s <sup>2</sup>

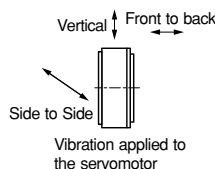

● **Vibration Class**

The vibration class at rated motor speed is V15. (A vibration class of V15 indicates a total vibration amplitude of 15 μm maximum on the servomotor during rated rotation.)

● **Enclosure**

Servomotor Type	Enclosure
Small-capacity Series	IP42 (except for gaps on the rotating section of the shaft)
Medium-capacity Series	IP44

## External Dimensions Units: mm

### ● Small-capacity Series

(1) Rated Torque 2.0 to 7.0 N·m (Outer Diameter 135 mm Inner Diameter 20 mm)

· Applicable Flange: 1

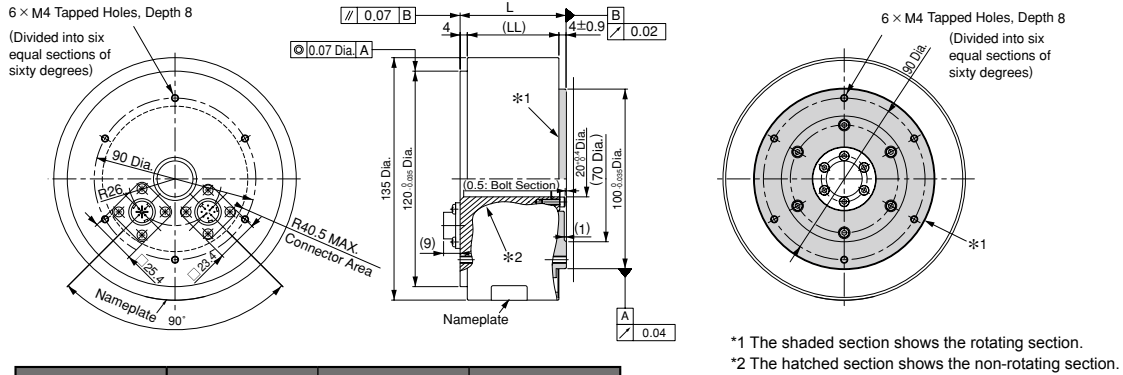

Model SGMCS-	L	(LL)	Approx. Mass kg
02B□C11	59	51	4.8
05B□C11	88	80	5.8
07B□C11	128	120	8.2

· Applicable Flange: 4

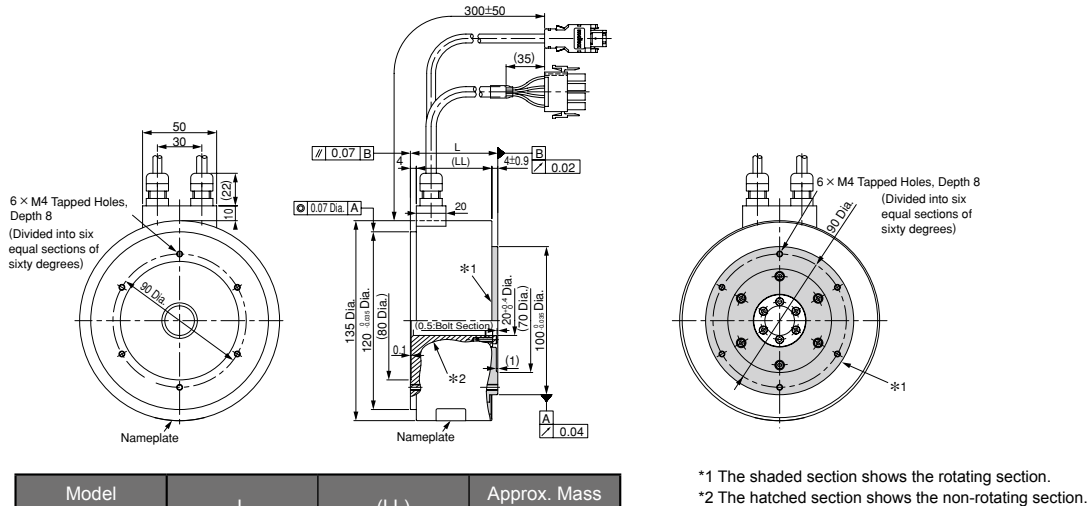

Model SGMCS-	L	(LL)	Approx. Mass kg
02B□C41	59	51	4.8
05B□C41	88	80	5.8
07B□C41	128	120	8.2

### ● Servomotor Connector for Small-capacity Series Servomotors (Applicable Flange: 1)

#### Servomotor-end Connector Specifications

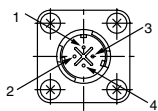

Model: JN1AS04MK2  
Manufacturer: Japan Aviation Electronics Industry, Ltd.  
Applicable plug: JN1DS04FK1  
(Provided by the customer.)

1	Phase U	Red
2	Phase V	White
3	Phase W	Blue
4	FG (Frame ground)	Green (yellow)

#### Encoder-end Connector Specifications

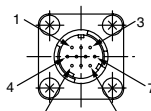

Model: JN1AS10ML1  
Manufacturer: Japan Aviation Electronics Industry, Ltd.  
Applicable plug: JN1DS10SL1  
(Provided by the customer.)

1	PS	Light blue	6	-	-
2	/PS	Light blue/ white	7	FG (Frame ground)	Shield
3	-	-	8	-	-
4	PG5V	Red	9	PG0V	Black
5	-	-	10	-	-

**External Dimensions** Units: mm

(2) Rated Torque 4.0 to 14.0 N·m (Outer Diameter 175 mm Inner Diameter 35 mm)

· Applicable Flange: 2

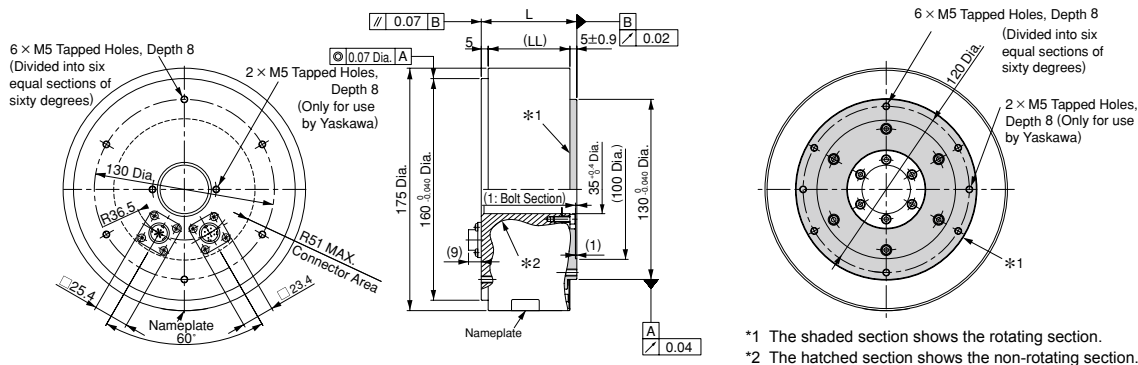

Model SGMCS-	L	(LL)	Approx. Mass kg
04C□C11	69	59	7.2
10C□C11	90	80	10.2
14C□C11	130	120	14.2

· Applicable Flange: 4

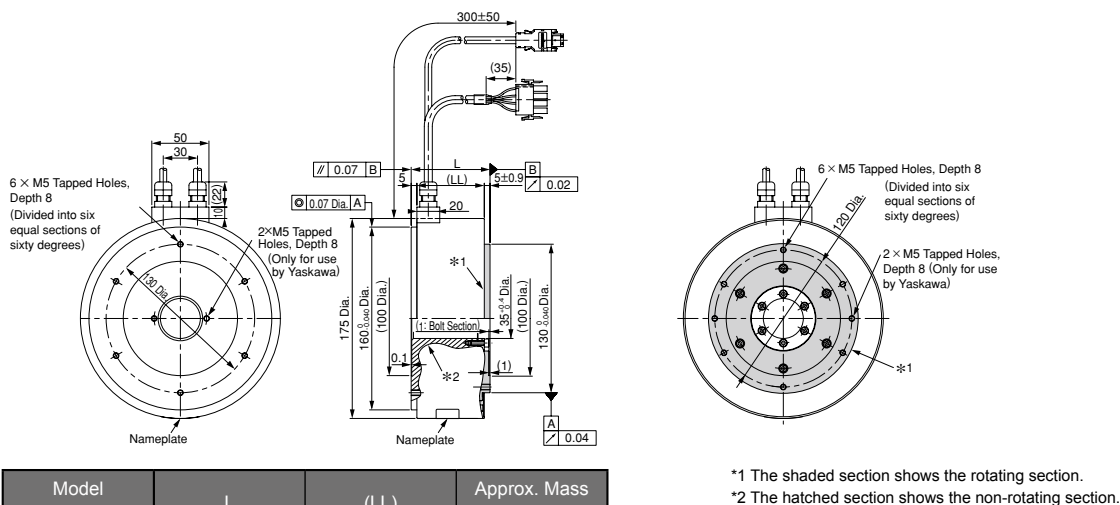

Model SGMCS-	L	(LL)	Approx. Mass kg
04C□C41	69	59	7.2
10C□C41	90	80	10.2
14C□C41	130	120	14.2

● Servomotor Connector (Applicable Flange: 4)

Servomotor-end Connector Specifications

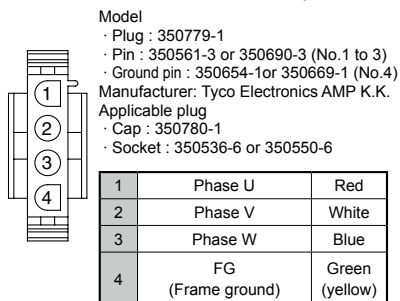

Encoder-end Connector Specifications

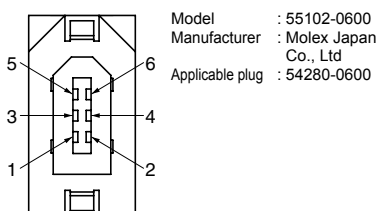

## External Dimensions Units: mm

(3) Rated Torque 8.0 to 25.0 N·m (Outer Diameter 230 mm Inner Diameter 60 mm)

· Applicable Flange: 1

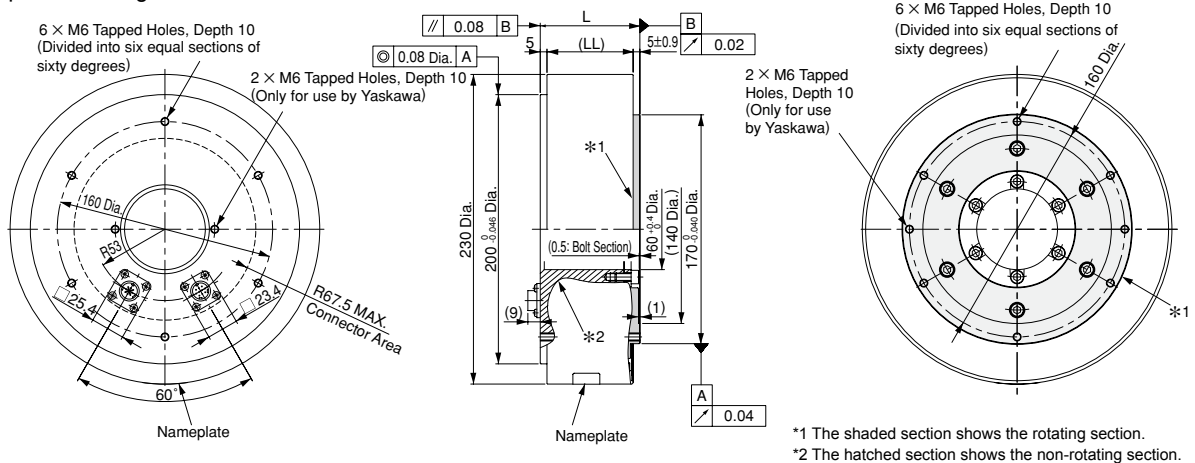

Model SGMCS-	L	(LL)	Approx. Mass kg
08D□C11	74	64	14.0
17D□C11	110	100	22.0
25D□C11	160	150	29.7

· Applicable Flange: 4

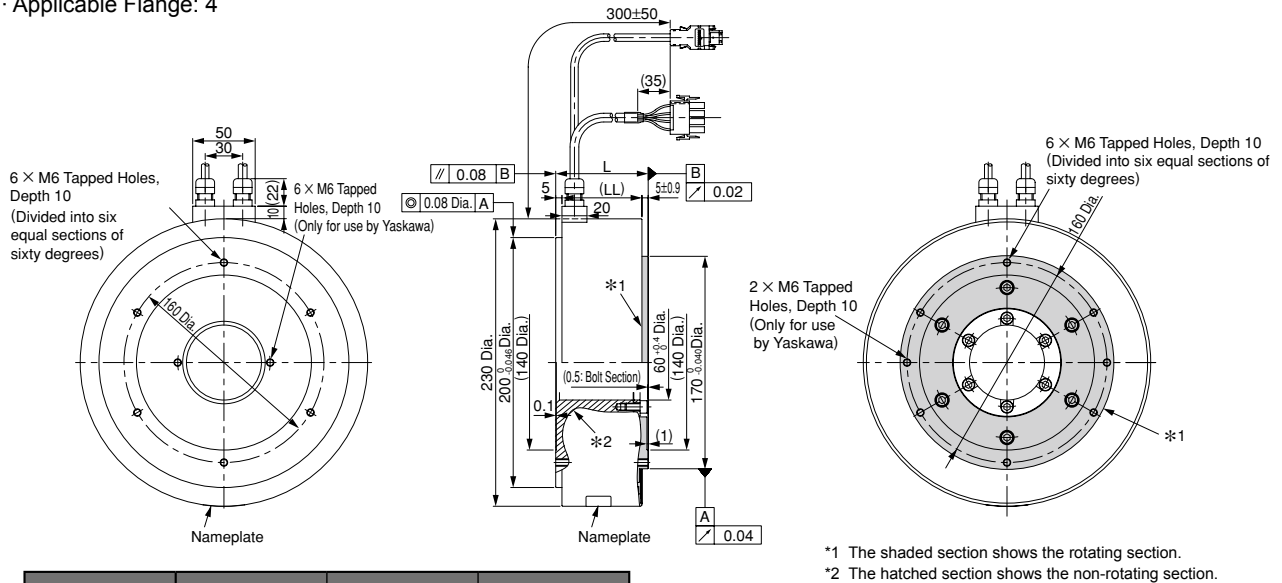

Model SGMCS-	L	(LL)	Approx. Mass kg
08D□C41	74	64	14.0
17D□C41	110	100	22.0
25D□C41	160	150	29.7

**External Dimensions** Units: mm

(4) Rated Torque 16.0 to 35.0 N·m (Outer Diameter 290 mm Inner Diameter 75 mm)

· Applicable Flange: 1

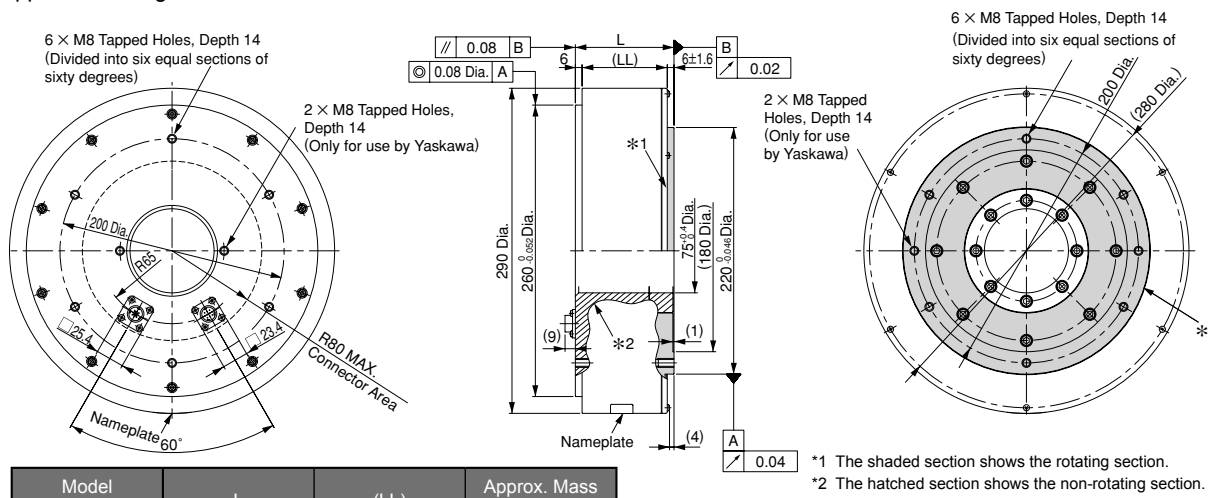

Model SGMCS-	L	(LL)	Approx. Mass kg
16E□B11	88	76	26.0
35E□B11	112	100	34.0

· Applicable Flange: 4

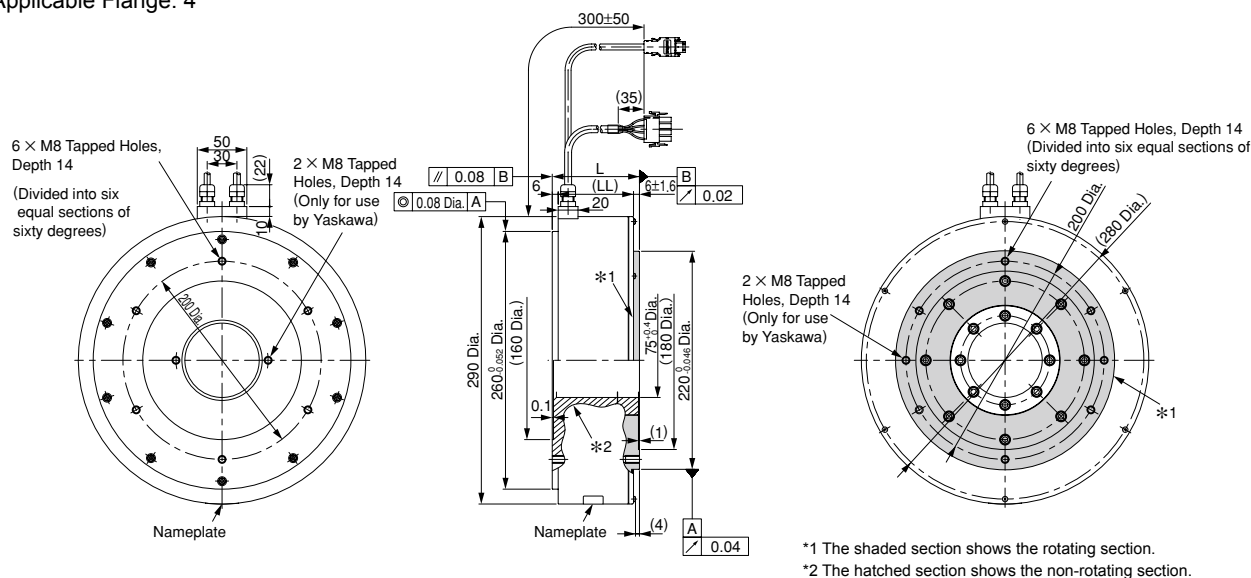

Model SGMCS-	L	(LL)	Approx. Mass kg
16E□B41	88	76	26.0
35E□B41	112	100	34.0

Direct Drive Servomotors

## External Dimensions Units: mm

### ● Medium-capacity Series

(1) Rated Torque 45 to 110 N·m (Outer Diameter 280 mm, Inner Diameter 75 mm)

· Applicable Flange: 1

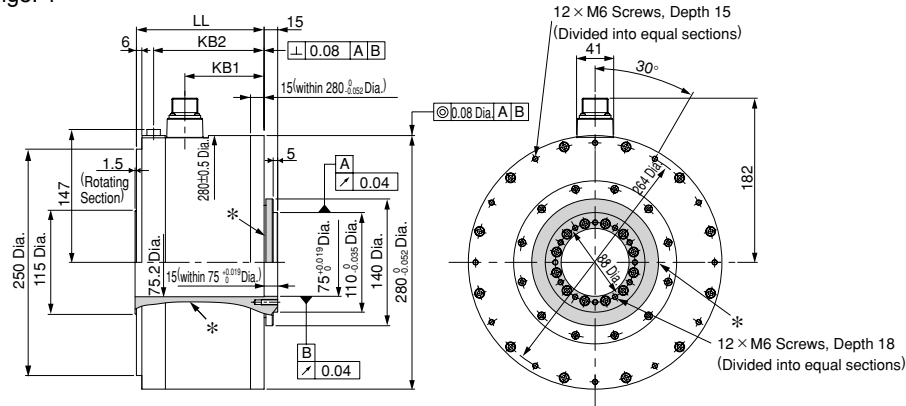

\*: The shaded section shows the rotating section.

Model SGMCS-	LL	KB1	KB2	Approx. Mass kg
45M□A11	141	87.5	122	38
80M□A11	191	137.5	172	45
1AM□A11	241	187.5	222	51

· Applicable Flange: 3

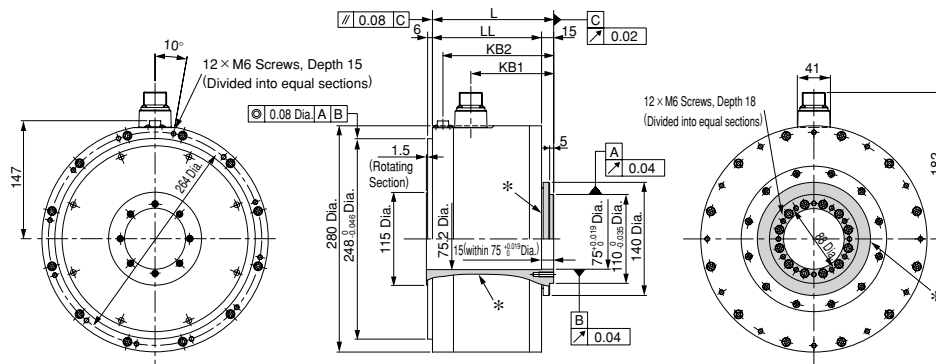

\*: The shaded section shows the rotating section.

Model SGMCS-	L	LL	KB1	KB2	Approx. Mass kg
45M□A31	150	135	102.5	137	38
80M□A31	200	185	152.5	187	45
1AM□A31	250	235	202.5	237	51

### ● Servomotor Connector for Medium-capacity Series Servomotors (Applicable Flange: 1, 3)

Servomotor-end Connector Specifications  
(Same for All Medium-capacity Models)

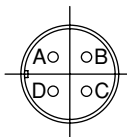

Model : CE05-2A18-10PD  
 Manufacturer : DDK Ltd.  
 Applicable plug and cable clamp  
 Plug : CE05-6A18-10SD-B-BSS  
 Cable clamp : CE3057-10A-□(D265)

A	Phase U
B	Phase V
C	Phase W
D	FG (Frame ground)

Encoder-end Connector Specifications  
(Same for All Medium-capacity Models)

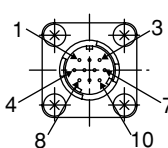

Model : JN1AS10ML1  
 Manufacturer : Japan Aviation  
 Electronics Industry, Ltd.  
 Applicable plug : JN1DS10SL1

1	PS	6	-
2	/PS	7	FG (Frame ground)
3	-	8	-
4	PG5V	9	PG0V
5	-	10	-

**External Dimensions** Units: mm

(2) Rated Torque 80 to 200 N·m (Outer Diameter 360 mm, Inner Diameter 118 mm)

· Applicable Flange: 2

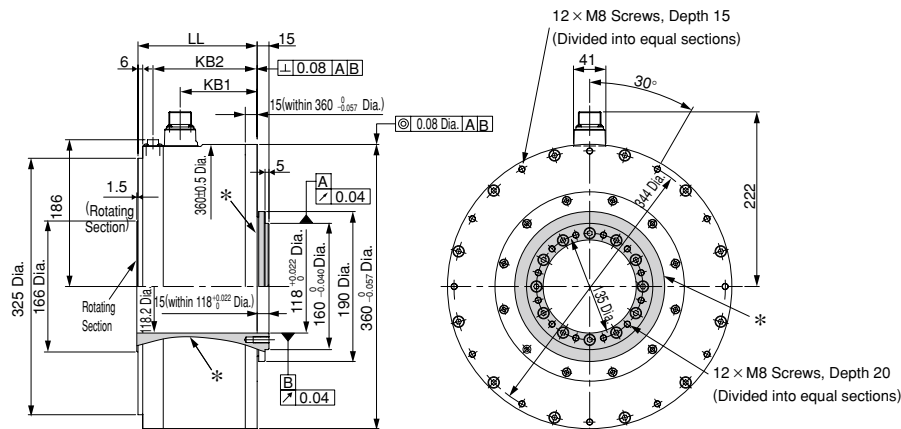

\*: The shaded section shows the rotating section.

Model SGMCS-	LL	KB1	KB2	Approx. Mass kg
80N□A11	151	98	132	50
1EN□A11	201	148	182	68
2ZN□A11	251	198	232	86

· Applicable Flange: 3

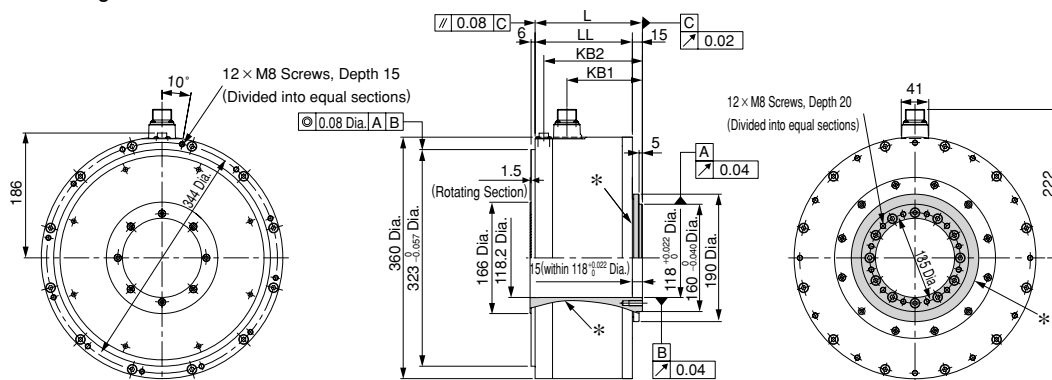

\*: The shaded section shows the rotating section.

Model SGMCS-	L	LL	KB1	KB2	Approx. Mass kg
80N□A31	160	145	113	147	50
1EN□A31	210	195	163	197	68
2ZN□A31	260	245	213	247	86

Direct Drive Servomotors



# Selecting Cables

## ● Cables Connections

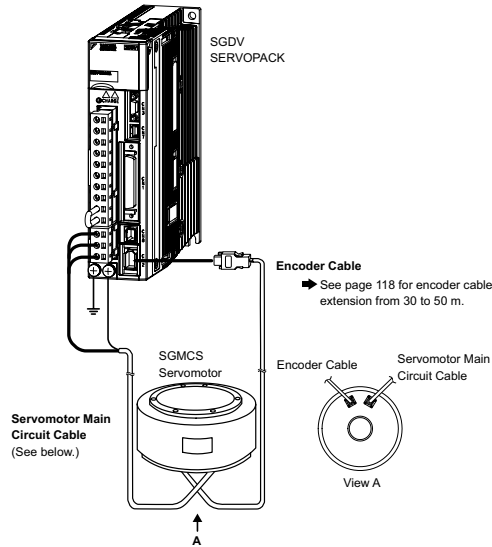

## ● Servomotor Main Circuit Cables

Name	Length (L)	Order No.		Specifications	Details	
		Standard Type	Flexible Type <sup>1</sup>			
Small Capacity (02B-35E)	Cable with Loose Wire at SERVOPACK End	3 m	JZSP-CMM60-03-E	JZSP-CSM60-03-E	Applicable Flange <sup>2</sup> : 1 SERVOPACK End 50 mm L Servomotor End M4 Crimped Terminals	(1)
		5 m	JZSP-CMM60-05-E	JZSP-CSM60-05-E		
		10 m	JZSP-CMM60-10-E	JZSP-CSM60-10-E		
		15 m	JZSP-CMM60-15-E	JZSP-CSM60-15-E		
		20 m	JZSP-CMM60-20-E	JZSP-CSM60-20-E		
	Cable with Loose Wire at SERVOPACK End	3 m	JZSP-CMM00-03-E	JZSP-CMM01-03-E	Applicable Flange <sup>2</sup> : 4 SERVOPACK End 8.5±0.5 (Exposed core wire) 50 L Servomotor End Sheath to Bind Core Wires Heat-shrinkable Tube M4 Crimped Terminals Cable: UL2517 (AWG20×4C) Cap : 350780-1(4-pole) Socket : 350536-6(Chained)	(1)
		5 m	JZSP-CMM00-05-E	JZSP-CMM01-05-E		
		10 m	JZSP-CMM00-10-E	JZSP-CMM01-10-E		
		15 m	JZSP-CMM00-15-E	JZSP-CMM01-15-E		
		20 m	JZSP-CMM00-20-E	JZSP-CMM01-20-E		
Servomotor-end Connector		JN1DS04FK1		Soldered	(3)	
Cables	5 m	JZSP-CSM90-05-E	JZSP-CSM80-05-E		(4)	
	10 m	JZSP-CSM90-10-E	JZSP-CSM80-10-E			
	15 m	JZSP-CSM90-15-E	JZSP-CSM80-15-E			
	20 m	JZSP-CSM90-20-E	JZSP-CSM80-20-E			
	50 m	JZSP-CSM90-50-E	JZSP-CSM80-50-E			
		Value Type	Premium Type <sup>3*</sup>			
Medium Capacity (45M, 80M, 80N, 1AM)	Cable with Loose Wire at SERVOPACK End	3 m	B1EV-03(A)-E	B1EP-03(A)-E		(2)
		5 m	B1EV-05(A)-E	B1EP-05(A)-E		
		10 m	B1EV-10(A)-E	B1EP-10(A)-E		
		15 m	B1EV-15(A)-E	B1EP-15(A)-E		
		20 m	B1EV-20(A)-E	B1EP-20(A)-E		
Medium Capacity (1EN, 2ZN)	Cable with Loose Wire at SERVOPACK End	3 m	B2EV-03(A)-E	B2EP-03(A)-E		
		5 m	B2EV-05(A)-E	B2EP-05(A)-E		
		10 m	B2EV-10(A)-E	B2EP-10(A)-E		
		15 m	B2EV-15(A)-E	B2EP-15(A)-E		
		20 m	B2EV-20(A)-E	B2EP-20(A)-E		

\*1: Use flexible cables for movable sections such as robot arms.

\*2: For applicable flanges, see model designations on page 105.

\*3 Premium cables are intended for use in applications that require CE. They have a continuous flex rating and are intended for use in movable sections such as robot arms.

### NOTES:

Shaded items are non-stock.

SGMCS servomotors with holding brakes are not available.

## Selecting Cables

### (1) Small Capacity Series: Wiring Specifications for Cables

#### • Applicable Flange: 1

SERVOPACK End		Servomotor End	
Wire Color	Signal	Signal	Pin No.
Red	Phase U	Phase U	1
White	Phase V	Phase V	2
Blue	Phase W	Phase W	3
Green/(yellow)	FG	FG	4

#### • Applicable Flange: 4

SERVOPACK End		Servomotor End	
Wire Color	Signal	Signal	Pin No.
Red	Phase U	Phase U	1
White	Phase V	Phase V	2
Blue	Phase W	Phase W	3
Green/(yellow)	FG	FG	4

### (2) Medium Capacity Series: Wiring Specifications for Cables

#### • Value Type

SERVOPACK-end Leads		Servomotor-end Connector	
Wire Label	Signal	Signal	Pin No.
G	FG	FG	D
W	Phase W	Phase W	C
V	Phase V	Phase V	B
U	Phase U	Phase U	A

\*For servomotors with holding brakes, the holding brake cable must also be wired.

#### • Premium Type

SERVOPACK-end Leads		Servomotor-end Connector	
Wire Label	Signal	Signal	Pin No.
G	FG	FG	D
W	Phase W	Phase W	C
V	Phase V	Phase V	B
U	Phase U	Phase U	A

\*For servomotors with holding brakes, the holding brake cable must also be wired.

### (3) Small-capacity Series: Servomotor-end Connector Specifications

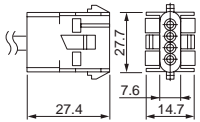
Items	Specifications
Manufacturer	Tyco Electronics AMP K.K.
Order No.	JZSP-CMM9-3-E
Cap	350780-1
Socket	350550-6
Applicable Wire Size	AWG20 to 14
Crimp Tool	Hand tool: 90296-2 Applicator: 687763-2
External Dimensions mm	

### (4) Small-capacity Series: Cable Specifications

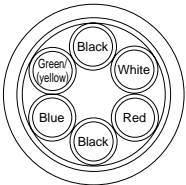
Items	Standard Type	Flexible Type
Order No.*	JZSP-CSM90-□□-E (50 m max.)	JZSP-CSM80-□□-E (50 m max.)
Specifications	UL2517 (Max. operating temperature: 105°C) AWG20×6C For power line: AWG20 (0.52 mm <sup>2</sup> ) Outer diameter of insulating sheath: 1.53 dia. mm For holding brake line: AWG20 (0.52 mm <sup>2</sup> ) Outer diameter of insulating sheath: 1.53 dia.mm	UL2517 (Max. operating temperature: 105°C) AWG22×6C For power line: AWG22 (0.33 mm <sup>2</sup> ) Outer diameter of insulating sheath: 1.37 dia. mm For holding brake line: AWG22 (0.33 mm <sup>2</sup> ) Outer diameter of insulating sheath: 1.37 dia. mm
Finished Dimensions	7 ± 0.3 mm	
Internal Configuration and Lead Color		
Yaskawa Standard Specifications (Standard Length)	Cable length : 5 m, 10 m, 15 m, 20 m, 50 m	

\*: Specify the cable length □□ of order no.  
Example: JZSP-CSM90-15-E (15 m)

## Selecting Cables

(Medium-capacity Series (SGMCS-□□M and N): Connector Specifications

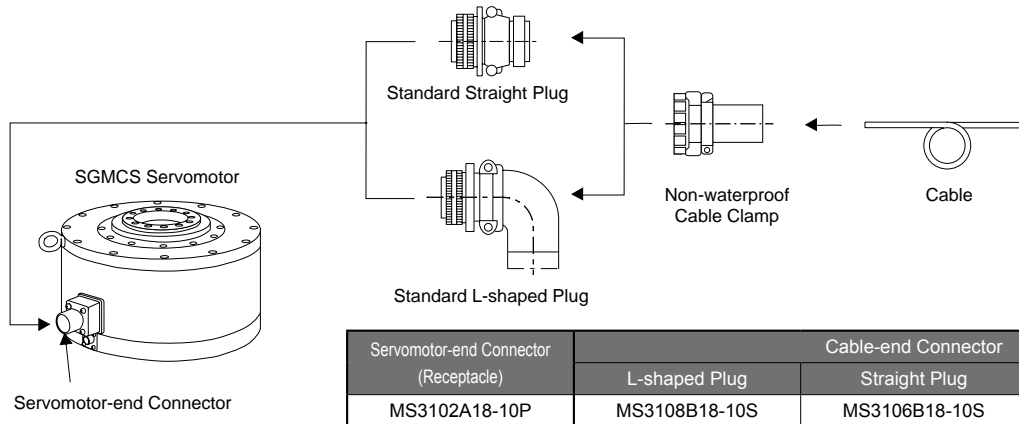

### · Dimensional Drawings: MS3108B L-shaped Plug Shell

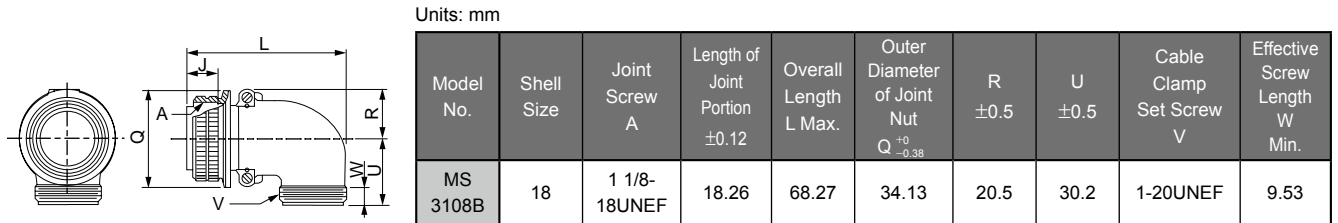

### · Dimensional Drawings: MS3106B Straight Plug Shell

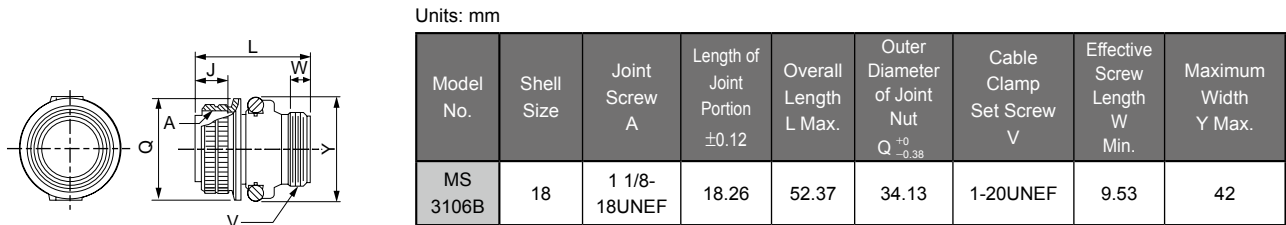

### · Dimensional Drawings: MS3057-10A Cable Clamp with Rubber Bushing

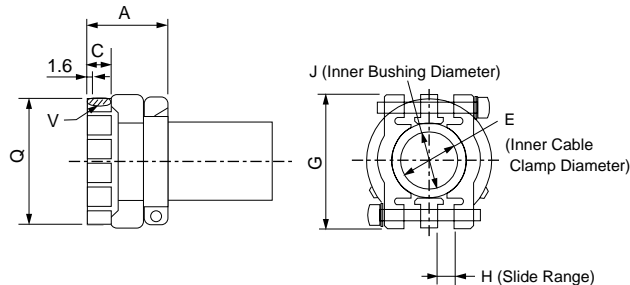





Units: mm

Model No.	Applicable Connector Shell Size	Overall Length A±0.7	Effective Screw Length C	E	G±0.7	H	J	Set Screw V	Outer Diameter Q±0.7	Attached Bushing
MS3057-10A	18	23.8	10.3	15.9	31.7	3.2	14.3	1-20UNEF	30.1	AN3420-10

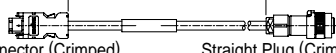
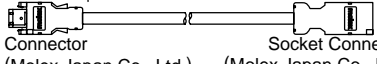
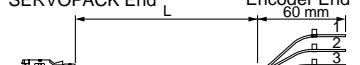
## Selecting Cables

### ● Encoder Cables and Connectors (Max. length: 20 m)

Name	Length (L)	Order No.		Specifications	Details		
		Standard Type	Flexible Type <sup>*1</sup>				
Cable with Connectors (For Incremental and Absolute Encoder)	3 m	JZSP-CMP60-03-E	JZSP-CSP60-03-E	Applicable Flange <sup>*2</sup> : 1, 3 SERVOPACK End  Encoder (Servomotor) End Connector (Crimped) (Molex Japan Co., Ltd.)      Straight Plug (Crimped) (Japan Aviation Electronics Industry, Ltd.)	(1)		
	5 m	JZSP-CMP60-05-E	JZSP-CSP60-05-E				
	10 m	JZSP-CMP60-10-E	JZSP-CSP60-10-E				
	15 m	JZSP-CMP60-15-E	JZSP-CSP60-15-E				
	20 m	JZSP-CMP60-20-E	JZSP-CSP60-20-E				
	3 m	JZSP-CMP00-03-E	JZSP-CMP10-03-E			Applicable Flange <sup>*2</sup> : 4 SERVOPACK End  Encoder End Connector (Molex Japan Co., Ltd.)      Socket Connector (Molex Japan Co., Ltd.)	(2)
	5 m	JZSP-CMP00-05-E	JZSP-CMP10-05-E				
	10 m	JZSP-CMP00-10-E	JZSP-CMP10-10-E				
	15 m	JZSP-CMP00-15-E	JZSP-CMP10-15-E				
	20 m	JZSP-CMP00-20-E	JZSP-CMP10-20-E				
Cable with Loose Wire at Encoder End (For Incremental and Absolute Encoder)	3 m	JZSP-CMP03-03-E	JZSP-CMP13-03-E	SERVOPACK End      Encoder End  Connector (Crimped) (Molex Japan Co., Ltd.)      Wire Markers 60 mm	(3)		
	5 m	JZSP-CMP03-05-E	JZSP-CMP13-05-E				
	10 m	JZSP-CMP03-10-E	JZSP-CMP13-10-E				
	15 m	JZSP-CMP03-15-E	JZSP-CMP13-15-E				
	20 m	JZSP-CMP03-20-E	JZSP-CMP13-20-E				
SERVOPACK-end Connector Kit		JZSP-CMP9-1-E		Soldered  (Molex Japan Co., Ltd.)	(4)		
Encoder-end Connector (Straight Plug)		JN1DS10SL1		Crimping Type (A crimp tool is required.) 			
Encoder-end Connector (Socket Contact)		JN1-22-22S-PKG100		(Japan Aviation Electronics Industry, Ltd.)			
Cables	5 m	JZSP-CMP09-05-E	JZSP-CSP39-05-E		(5)		
	10 m	JZSP-CMP09-10-E	JZSP-CSP39-10-E				
	15 m	JZSP-CMP09-15-E	JZSP-CSP39-15-E				
	20 m	JZSP-CMP09-20-E	JZSP-CSP39-20-E				

\*1: Use flexible cables for movable sections such as robot arms.

\*2: For applicable flanges, see model designations on page 105.

NOTE: Shaded items are non-stock.

Direct Drive Servomotors

#### (1) Wiring Specifications for Cable with Connectors

- Applicable Flange: 1, 3

(Standard type)

SERVOPACK End		Encoder (Servomotor) End	
Pin No.	Signal	Pin No.	Wire Color
1	PG5V	4	Red
2	PG0V	9	Black
5	PS	1	Light blue
6	/PS	2	Light blue/white
Shell	FG	7	FG Shield wire

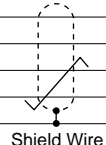

Shield Wire

Note: Be sure to connect the shield wire of encoder cable to the connector case (shell).

(Flexible type)

SERVOPACK End		Encoder End	
Pin No.	Signal	Pin No.	Wire Color
1	PG5V	4	Orange
2	PG0V	9	Green
5	PS	1	Black/light blue
6	/PS	2	Red/light blue
Shell	FG	7	FG Shield wire

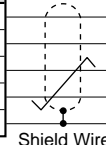

Shield Wire

#### (2) Wiring Specifications for Cable with Connectors

- Applicable Flange: 4

(Standard type)

SERVOPACK End		Encoder (Servomotor) End	
Pin No.	Signal	Pin No.	Wire Color
1	PG5V	1	Red
2	PG0V	2	Black
5	PS	5	Light blue
6	/PS	6	Light blue/white
Shell	FG	7	FG Shield wire

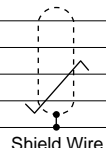

Shield Wire

Note: Be sure to connect the shield wire of encoder cable to the connector case (shell).

(Flexible type)

SERVOPACK End		Encoder End	
Pin No.	Signal	Pin No.	Wire Color
1	PG5V	1	Orange
2	PG0V	2	Green
5	PS	5	Red/light blue
6	/PS	6	Black/light blue
Shell	FG	7	FG Shield wire

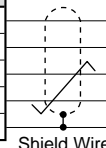

Shield Wire

## Selecting Cables

### (3) Wiring Specifications for Cable with Loose Wire at Encoder End

(Standard type)

SERVOPACK End		Encoder (Servomotor) End	
Pin No.	Signal	Wire Color	Marker
6	/PS	Light blue/white	6
5	PS	Light blue	5
4	BAT(-)	Orange/white	4
3	BAT(+)	Orange	3
2	PG0V	Black	2
1	PG5V	Red	1
Shell	FG		

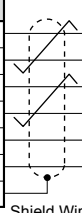

Shield Wire

(Flexible type)

SERVOPACK End		Encoder (Servomotor) End	
Pin No.	Signal	Wire Color	Marker
1	PG5V	Orange	1
2	PG0V	Green	2
3	BAT(+)	Red/pink	3
4	BAT(-)	Black/pink	4
5	PS	Red/light blue	5
6	/PS	Black/light blue	6
Shell	FG		

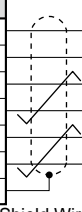

Shield Wire

- Notes: 1 The signals BAT (+) and BAT (-) are not needed when using single turn absolute feedback.  
2 Be sure to connect the shield wire of encoder cable to the connector case (shell).

### (4) SERVOPACK-end Connector Specifications

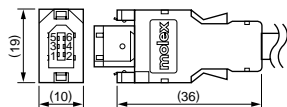
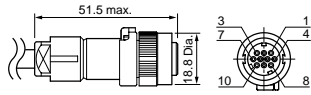
Items	SERVOPACK End	Encoder End
Order No.	JZSP-CMP9-1-E	Tools are not included.
Manufacturer	Molex Japan Co., Ltd.	Japan Aviation Electronics Industry, Ltd.
Connector	55100-0670 (soldered)  Note: 55100-0670 (soldered) when using a connector kit	Straight plug: JN1DS10SL1 (crimped) Socket contact type: JN1-22-22S-PKG100 Outer diameter of applicable cable : 5.7 dia. to 7.3 dia. mm Applicable wire size: AWG21 to 25 Outer diameter of insulating sheath: 0.8 dia. to 1.5 dia. mm Crimp tool (hand tool) model: CT150-2-JN
External Dimensions (Units: mm)		

### (5) Cable Specifications

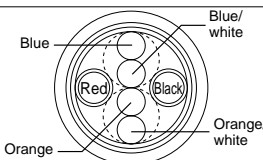
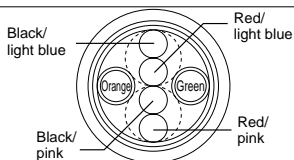
Items	Standard Type	Flexible Type
Order No.*	JZSP-CMP09-□□-E	JZSP-CSP39-□□-E
Cable Length	20 m max.	
Specifications	UL20276 (Rated temperature: 80°C) AWG22×2C+AWG24×2P AWG22 (0.33 mm <sup>2</sup> ) Outer diameter of insulating sheath: 1.15 dia. mm AWG24 (0.20 mm <sup>2</sup> ) Outer diameter of insulating sheath: 1.09 dia. mm	UL20276 (Rated temperature: 80°C) AWG22×2C+AWG24×2P AWG22 (0.33 mm <sup>2</sup> ) Outer diameter of insulating sheath: 1.35 dia. mm AWG24 (0.20 mm <sup>2</sup> ) Outer diameter of insulating sheath: 1.21 dia. mm
Finished Dimensions	6.5 dia. mm	6.8 dia. mm
Internal Configuration and Lead Colors		
Yaskawa Standard Specifications (Standard Length)	Cable length: 5 m, 10 m, 15 m, 20 m	

\* Specify the cable length in □□ of order no.  
Example: JZSP-CMP09-05-E (5 m)

## Selecting Cables

### ● Relay Encoder Cables (For extending from 30 to 50 m)

Name	Length	Order No. Standard Type	Specifications	Details
Encoder-end Cables (For incremental and absolute encoder)	0.3 m	JZSP-CSP15-E		(1)
Cable with Connectors (For incremental and absolute encoder)	30 m	JZSP-UCMP00-30-E		(2)
	40 m	JZSP-UCMP00-40-E		
	50 m	JZSP-UCMP00-50-E		
Cables	30 m	JZSP-CMP19-30-E		(3)
	40 m	JZSP-CMP19-40-E		
	50 m	JZSP-CMP19-50-E		

#### (1) Wiring Specifications for Encoder-end Cable

SERVOPACK End		Encoder (Servomotor) End	
Pin No.	Signal	Pin No.	Wire Color
1	PG 5V	4	Red
2	PG 0V	9	Black
5	PS	1	Light blue
6	/PS	2	Light blue/white
Shell	FG	7	FG Shield wire

Note: Be sure to connect the shield wire of encoder cable to the connector case (shell).

#### (2) Wiring Specifications for Cable with Connectors

SERVOPACK End		Encoder (Servomotor) End	
Pin No.	Signal	Pin No.	Wire Color
6	/PS	6	Light blue/white
5	PS	5	Light blue
4	BAT (-)	4	Orange/white
3	BAT (+)	3	Orange
2	PG 0V	2	Black
1	PG 5V	1	Red
Shell	FG	Shell	FG

#### (3) Cable Specifications

Items	Standard Type
Order No.*	JZSP-CMP19-□□-E
Cable Length	50 m max.
Specifications	UL20276 (Rated temperature: 80°C) AWG16×2C+AWG26×2P AWG16 (1.31 mm <sup>2</sup> ) Outer diameter of insulating sheath: 2.0 dia.mm AWG26 (0.13 mm <sup>2</sup> ) Outer diameter of insulating sheath: 0.91 dia. mm
Finished Dimensions	6.8 dia. mm
Internal Configuration and Lead Colors	
Yaskawa Standard Specifications (Standard Length)	Cable length: 30 m, 40 m, 50 m

\* Specify the cable length in □□ of order no.  
Example: JZSP-CMP19-30-E (30 m)

# Linear Servomotors

# SGLGW

(Coreless Type)

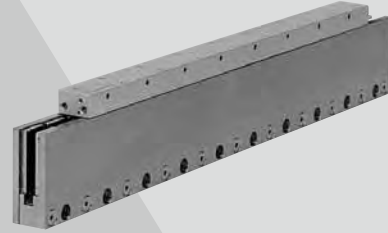

## Model Designations

### ● Moving Coil

**SGL G W - 30 A 050 C P**

Linear  $\Sigma$  Series  
Linear Servomotor

Servomotor Type

Code	Specifications
G	Coreless

W : Moving Coil

Magnet Height

Voltage

A: 200 VAC

Length of Moving Coil

Design Revision Order  
A, B, C...

Connector for Main Circuit Cable

Code	Specifications	Applicable Model
Blank	Connector by Tyco Electronics AMP K.K.	All models
D	Connector by Interconnectron GmbH	SGLGW -30A, -40A, -60A

Hall Sensor/Cooling Method

Code	Specifications	Applicable Model
P	With hall sensor	All models
C	Forced cooling	SGLGW-40A, -60A, -90A
H	With hall sensor and forced cooling	
Blank	Without hall sensor	All models

### ● Magnetic Way

**SGL G M - 30 108 A**

Linear  $\Sigma$  Series  
Linear Servomotor

Servomotor Type

Code	Specifications
G	Coreless

M: Magnetic Way

Magnet Height

Length of Magnetic Way

Options

Code	Specifications	Applicable Model
Blank	(standard)	All models
-M	High force	SGLGM-40, -60

Design Revision Order  
A, B, C\*...

\*: The coreless linear servomotor has revision CT.  
C = without mounting holes on the bottom  
CT = with mounting holes on the bottom

NOTE: Shaded items are non-stock.

- Direct-feed mechanism for high-speed and high-precision positioning.
- Lack of magnetic attraction force helps extend the life of linear motion guides and minimizes noise.
- Zero cogging for minimal force ripple.
- Feeders and loaders
- Semiconductor equipment
- LCD manufacturing equipment

### ● Precautions on Moving Coil with Hall Sensor

When using a moving coil with a hall sensor, the magnetic way must completely cover the bottom of the hall sensor. Refer to the example showing the correct installation.

When determining the length of the moving coil's stroke or the length of the magnetic way, consider the total length of the moving coil and the hall sensor unit. Refer to the following table.

<Correct>

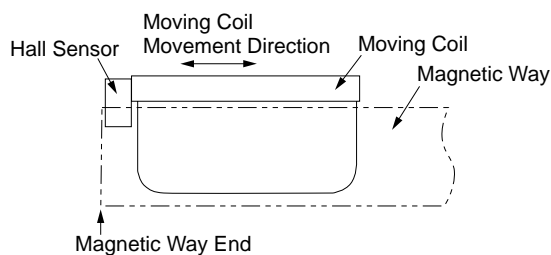

<Incorrect>

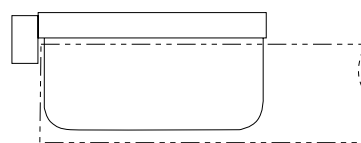

The total length of moving coil with hall sensor

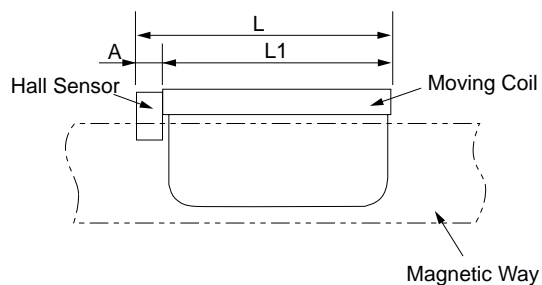

Moving Coil Model SGLGW-	Length of Moving Coil L1 (mm)	Length of Hall Sensor Unit A (mm)	Total Length L (mm)
30A050□P□	50	0 (Included in the length of moving coil)	50
30A080□P□	80		80
40A140□P□	140	16	156
40A253□P□	252.5		268.5
40A365□P□	365		381
60A140□P□	140	16	156
60A253□P□	252.5		268.5
60A365□P□	365		381
90A200□P□	199	0 (Included in the length of moving coil)	199
90A370□P□	367		367
90A535□P□	535		535



## Ratings and Specifications

Time Rating: Continuous

Insulation Resistance: 500 VDC, 10 M $\Omega$  min.

Ambient Temperature: 0 to 40°C

Excitation: Permanent magnet

Withstand Voltage: 1500 VAC for one minute

Enclosure: Self-cooled, air-cooling (Only self-cooled type available for SGLGW-30A linear servomotor)

Ambient Humidity: 20% to 80% (no condensation)

Allowable Winding Temperature: 130°C (Thermal class B)

### ● With Standard-force Magnetic Ways

Linear Servomotor Model SGLGW- <input type="text"/>		30A			40A			60A			90A		
		050C	080C	140C	253C	365C	140C	253C	365C	200C	370C	535C	
Peak Speed*	m/s	5	5	5	5	5	4.8	4.8	4.8	4	4	4	
Rated Force*	N	12.5	25	47	93	140	70	140	210	325	550	750	
Rated Current*	A <sub>rms</sub>	0.51	0.79	0.8	1.6	2.4	1.2	2.2	3.3	4.4	7.5	10.2	
Peak Force*	N	40	80	140	280	420	220	440	660	1300	2200	3000	
Peak Current*	A <sub>rms</sub>	1.62	2.53	2.4	4.9	7.3	3.5	7.0	10.5	17.6	30.0	40.8	
Moving Coil Mass	kg	0.10	0.15	0.34	0.60	0.87	0.42	0.76	1.10	2.15	3.6	4.9	
Force Constant	N/A <sub>rms</sub>	26.4	33.9	61.5	61.5	61.5	66.6	66.6	66.6	78.0	78.0	78.0	
BEMF Constant	V/(m/s)	8.8	11.3	20.5	20.5	20.5	22.2	22.2	22.2	26.0	26.0	26.0	
Motor Constant	N/ $\sqrt{W}$	3.7	5.6	7.8	11.0	13.5	11.1	15.7	19.2	26.0	36.8	45.0	
Electrical Time Constant	ms	0.2	0.4	0.4	0.4	0.4	0.5	0.5	0.5	1.4	1.4	1.4	
Mechanical Time Constant	ms	7.30	4.78	5.59	4.96	4.77	3.41	3.08	2.98	3.18	2.66	2.42	
Thermal Resistance (With heat sink)	K/W	5.19	3.11	1.67	0.87	0.58	1.56	0.77	0.51	0.39	0.26	0.22	
Thermal Resistance (Without heat sink)	K/W	8.13	6.32	3.02	1.80	1.23	2.59	1.48	1.15	1.09	0.63	0.47	
Magnetic Attraction	N	0	0	0	0	0	0	0	0	0	0	0	
Applicable SERVOPACK	SGDV	R70A	R90A	R90A	1R6A	2R8A	1R6A	2R8A	5R5A	120A	180A	200A	

Notes: 1 The items marked with an \* and Force and Speed Characteristics (the table on the next page) are the values at a motor winding temperature of 100°C during operation in combination with a SERVOPACK. The others are at 20°C.

2 The above specifications show the values under the cooling condition when a heat sink (aluminium board) listed in the following table is mounted on the moving coil.

Heat Sink Size	Models
200 mm × 300 mm × 12 mm	SGLGW-30A050C, -30A080C, -40A140C, -60A140C
300 mm × 400 mm × 12 mm	SGLGW-40A253C, -60A253C
400 mm × 500 mm × 12 mm	SGLGW-40A365C, -60A365C
800 mm × 900 mm × 12 mm	SGLGW-90A200C, -90A370C, -90A535C

Ratings and Specifications

● Force and Speed Characteristics **A** : Continuous Duty Zone **B** : Intermittent Duty Zone

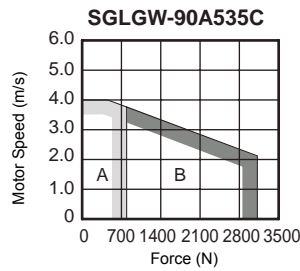
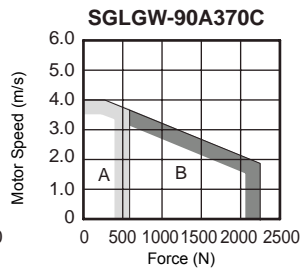
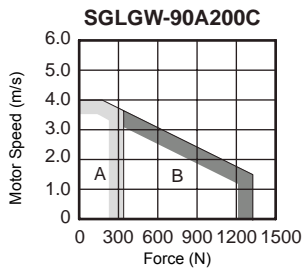
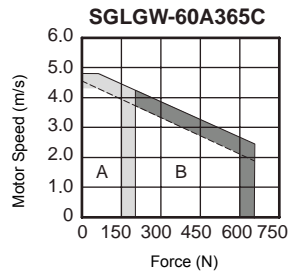
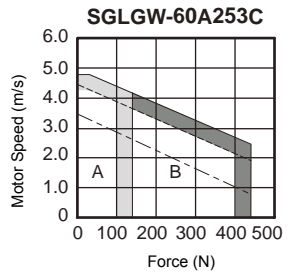
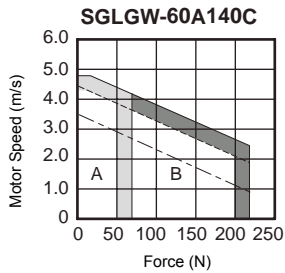
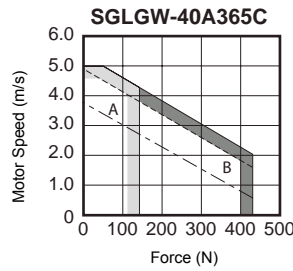
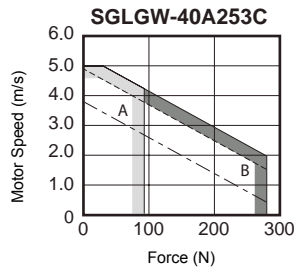
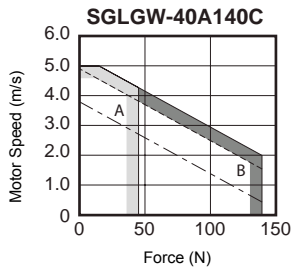
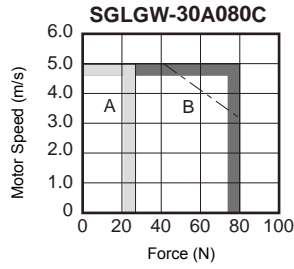
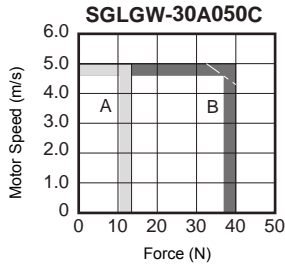

Notes:

- When the effective force during intermittent duty is within the rated force, the servomotor can be used within the intermittent duty zone.
- The solid, dotted, and dashed-dotted lines of the intermittent duty zone indicate the characteristics when a servomotor runs with the following combinations:
  - The solid line: With a three-phase 200 V or a single-phase 230 V SERVOPACK
  - The dotted line: With a single-phase 200 V SERVOPACK
  - The dashed-dotted line: With a single-phase 100 V SERVOPACK

## Ratings and Specifications

### ● With High-force Magnetic Ways

Linear Servomotor Model SGLGW- <span style="border: 1px solid black; padding: 0 5px;"> </span>		40A			60A		
		140C	253C	365C	140C	253C	365C
Peak Speed*	m/s	4.2	4.2	4.2	4.2	4.2	4.2
Rated Force*	N	57	114	171	85	170	255
Rated Current*	$A_{rms}$	0.8	1.6	2.4	1.2	2.2	3.3
Peak Force*	N	230	460	690	360	720	1080
Peak Current*	$A_{rms}$	3.2	6.5	9.7	5.0	10.0	14.9
Moving Coil Mass	kg	0.34	0.60	0.87	0.42	0.76	1.10
Force Constant	$N/A_{rms}$	76.0	76.0	76.0	77.4	77.4	77.4
BEMF Constant	$V/(m/s)$	25.3	25.3	25.3	25.8	25.8	25.8
Motor Constant	$N/\sqrt{W}$	9.6	13.6	16.7	12.9	18.2	22.3
Electrical Time Constant	ms	0.4	0.4	0.4	0.5	0.5	0.5
Mechanical Time Constant	ms	3.69	3.24	3.12	2.52	2.29	2.21
Thermal Resistance (With heat sink)	K/W	1.67	0.87	0.58	1.56	0.77	0.51
Thermal Resistance (Without heat sink)	K/W	3.02	1.80	1.23	2.59	1.48	1.15
Magnetic Attraction	N	0	0	0	0	0	0
Applicable SERVOPACK	SGDV	1R6A	2R8A	3R8A	1R6A	3R8A	7R6A

Notes: 1 The items marked with an \* and Force and Speed Characteristics (the table on the next page) are the values at a motor winding temperature of 100°C during operation in combination with a SERVOPACK. The others are at 20°C.

2 The above specifications show the values under the cooling condition when a heat sink (aluminium board) listed in the following table is mounted on the moving coil.

Heat Sink Size	200 mm × 300 mm × 12 mm : SGLGW-40A140C, -60A140C
	300 mm × 400 mm × 12 mm : SGLGW-40A253C, -60A253C
	400 mm × 500 mm × 12 mm : SGLGW-40A365C, -60A365C

## Ratings and Specifications

### ● Force and Speed Characteristics **A** : Continuous Duty Zone **B** : Intermittent Duty Zone

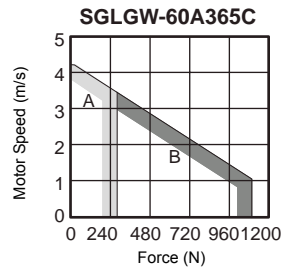
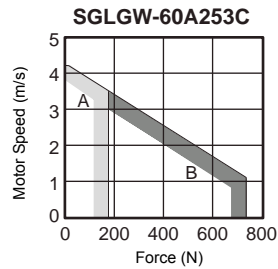
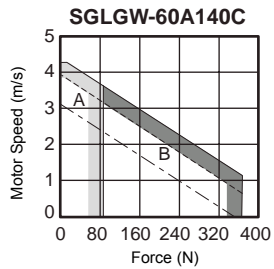
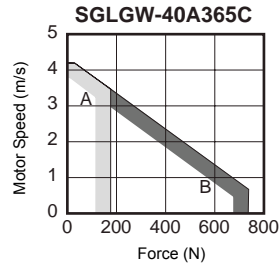
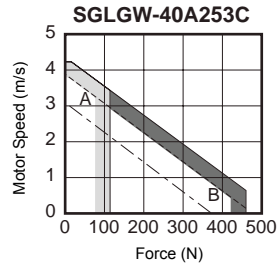
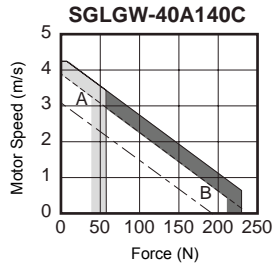

#### Notes:

- When the effective force during intermittent duty is within the rated force, the servomotor can be used within the intermittent duty zone.
- The solid, dotted, and dashed-dotted lines of the intermittent duty zone indicate the characteristics when a servomotor runs with the following combinations:
  - The solid line: With a three-phase 200 V or a single-phase 230 V SERVOPACK
  - The dotted line: With a single-phase 200 V SERVOPACK
  - The dashed-dotted line: With a single-phase 100 V SERVOPACK

### ● Mechanical Specifications

#### (1) Impact Resistance

- Impact acceleration: 196 m/s<sup>2</sup>
- Impact occurrences: twice

#### (2) Vibration Resistance

The linear servomotors will withstand the following vibration acceleration in three directions: Vertical, side to side, and front to back.

- Vibration acceleration: 49 m/s<sup>2</sup>

## External Dimensions Units: mm

### (1) SGLGW-30

- Moving Coil: SGLGW-30A□□□C□ (With a connector by Tyco Electronics AMP K.K.)

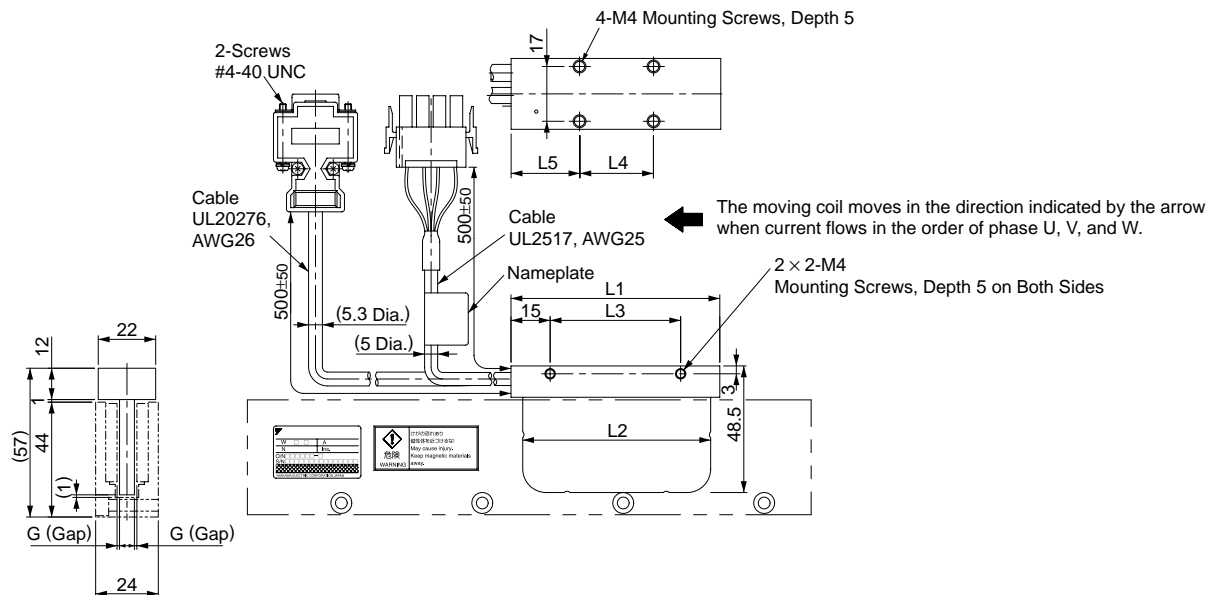

#### Hall Sensor Connector Specifications

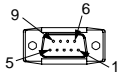

Pin Connector:  
17JE-23090-02 (D8C)  
by DDK Ltd.

#### The Mating Connector

Socket Connector  
: 17JE-13090-02 (D8C)  
Stud : 17L-002C or  
17L-002C1

Pin No.	Signal
1	+5V (Power supply)
2	Phase U
3	Phase V
4	Phase W
5	0V (Power supply)
6	Not used
7	Not used
8	Not used
9	Not used

#### Linear Servomotor Connector Specifications

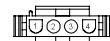

Plug : 350779-1  
Pin : 350924-1 or  
770672-1  
by Tyco Electronics AMP K.K.

#### The Mating Connector

Cap : 350780-1  
Socket : 350925-1 or  
770673-1

Pin No.	Signal	Wire Color
1	Phase U	Red
2	Phase V	White
3	Phase W	Blue
4	FG	Green

#### Hall Sensor Output Signals

When the moving coil moves in the direction indicated by the arrow in the figure, the relationship between the hall sensor output signals  $S_u$ ,  $S_v$ ,  $S_w$  and the inverse power of each motor phase  $V_u$ ,  $V_v$ ,  $V_w$  becomes as shown in the figure below.

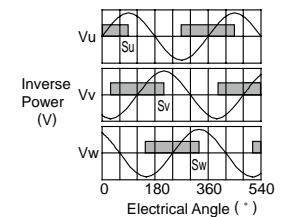

Moving Coil Model SGLGW-	L1	L2	L3	L4	L5	G (Gap)	Approx. Mass* kg
30A050C□	50	48	30	20	20	0.85	0.14
30A080C□	80	72	50	30	25	0.95	0.19

\*: The values indicate the mass of moving coil with a hall sensor unit.

**External Dimensions** Units: mm

- Moving Coil: SGLGW-30A□□□□D (With a connector by Interconnectron GmbH)

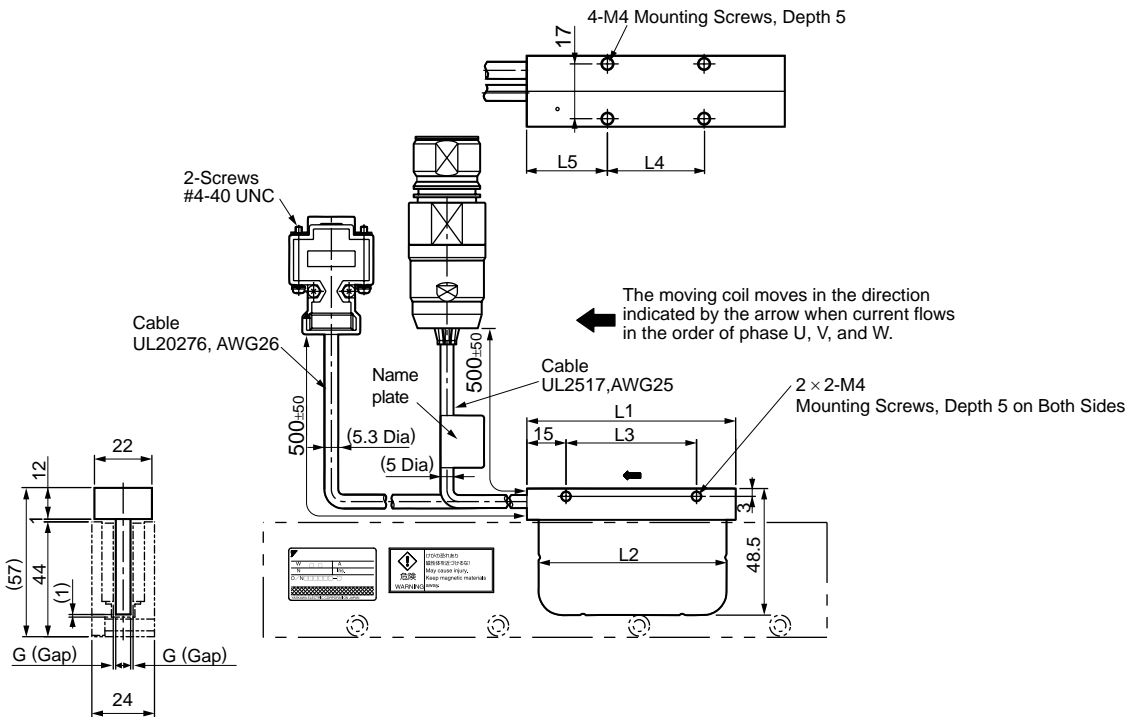

**Hall Sensor Connector Specifications**

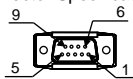

Pin Connector : 17JE-23090-02 (D8C) by DDK Ltd.

The Mating Connector  
 Socket Connector : 17JE-13090-02 (D8C)  
 Stud : 17L-002C or 17L-002C1

Pin No.	Signal
1	+5V (Power supply)
2	Phase U
3	Phase V
4	Phase W
5	0V (Power supply)
6	Not used
7	Not used
8	Not used
9	Not used

**Linear Servomotor Connector Specifications**

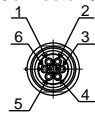

Extension: SROC06JM5CN169  
 Pin : 021.423.1020  
 by Interconnectron GmbH

The Mating Connector  
 Plug : SPUC06KFSDN236  
 Socket: 020.030.1020

Pin No.	Signal	Wire Color
1	Phase U	Red
2	Phase V	White
3	Phase W	Blue
4	Not used	-
5	Not used	-
6	FG	Green

**Hall Sensor Output Signals**

When the moving coil moves in the direction indicated by the arrow in the figure, the relationship between the hall sensor output signals Su, Sv, Sw and the inverse power of each motor phase Vu, Vv, Vw becomes as shown in the figure below.

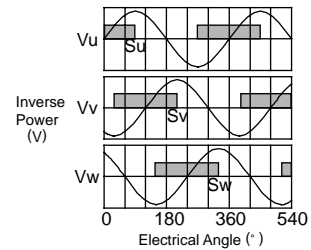

Moving Coil Model SGLGW-	L1	L2	L3	L4	L5	G (Gap)	Approx. Mass* kg
30A050C□□D	50	48	30	20	20	0.85	0.14
30A080C□□D	80	72	50	30	25	0.95	0.19

\*: The values indicate the mass of moving coil with a hall sensor unit.

# External Dimensions Units: mm

● Magnetic Way: SGLGM-30□□□A

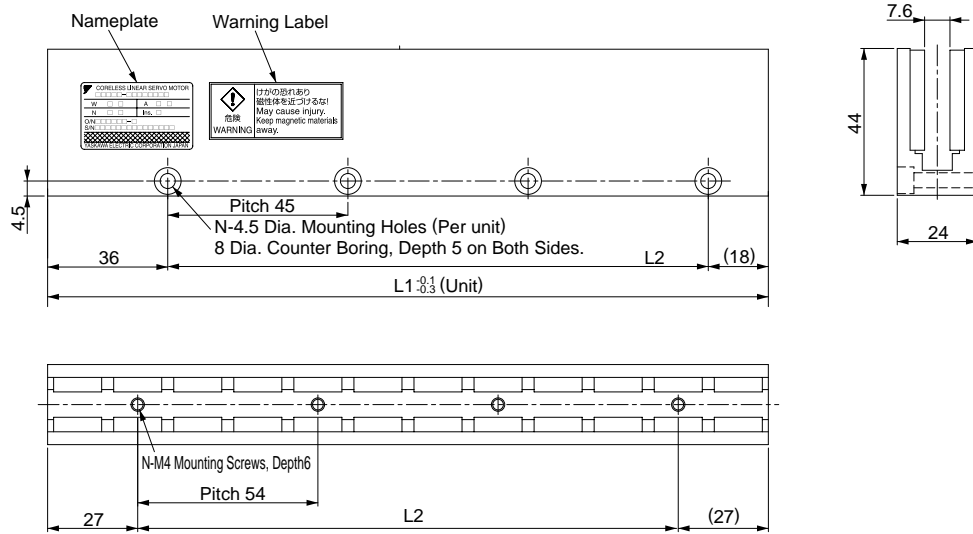

Magnetic Way Model SGLGM-	L1	L2	N	Approx. Mass kg
30108A	108	54	2	0.6
30216A	216	162	4	1.1
30432A	432	378	8	2.3

Note: If you have a pacemaker or any other electronic medical device, do not go near the magnetic way of the linear servomotor.

**External Dimensions** Units: mm

(2) SGLGW-40

- Moving Coil: SGLGW-40A□□□□□ (With a connector by Tyco Electronics AMP K.K.)

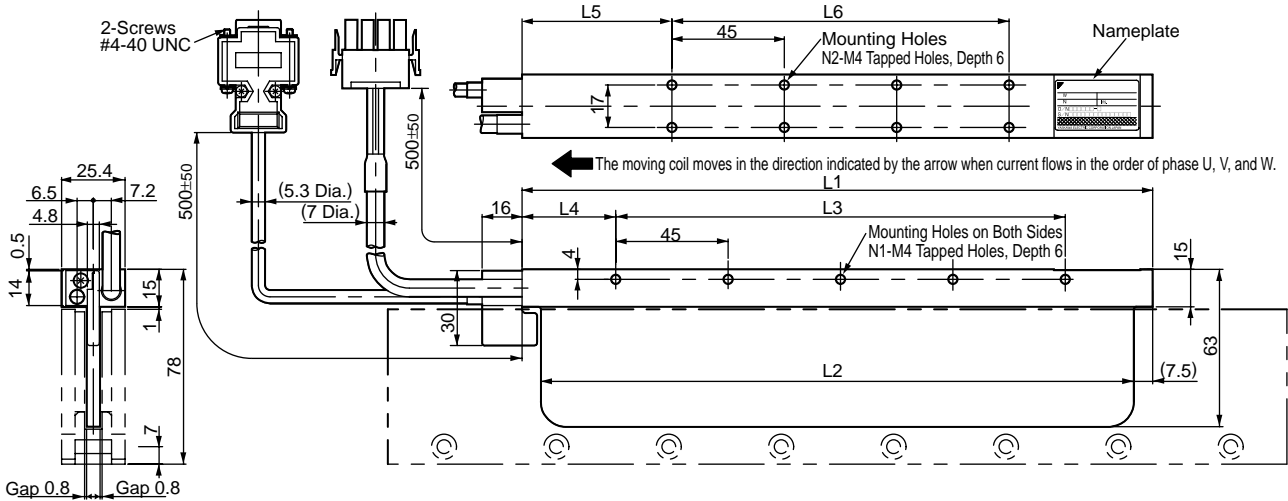

**Hall Sensor Connector Specifications**

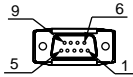

Pin Connector :  
17JE-23090-02 (D8C)  
by DDK Ltd.

The Mating Connector

Socket Connector :  
17JE-13090-02 (D8C)  
Stud : 17L-002C or  
17L-002C1

Pin No.	Signal
1	+5V (Power supply)
2	Phase U
3	Phase V
4	Phase W
5	0V (Power supply)
6	Not used
7	Not used
8	Not used
9	Not used

**Linear Servomotor Connector Specifications**



Plug : 350779-1  
Pin : 350561-3 or  
350690-3 (No.1 to 3)  
350654-1  
350669-1 (No.4)  
by Tyco Electronics AMP K.K.

The Mating Connector

Cap : 350780-1  
Socket : 350570-3 or  
350689-3

Pin No.	Signal	Wire Color
1	Phase U	Red
2	Phase V	White
3	Phase W	Blue
4	FG	Green

**Hall Sensor Output Signals**

When the moving coil moves in the direction indicated by the arrow in the figure, the relationship between the hall sensor output signals Su, Sv, Sw and the inverse power of each motor phase Vu, Vv, Vw becomes as shown in the figure below.

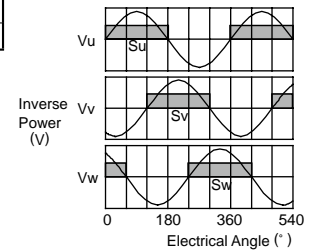

Moving Coil Model SGLGW-	L1	L2	L3	L4	L5	L6	N1	N2	Approx. Mass* kg
40A140C□	140	125	90	30	52.5	45	3	4	0.40
40A253C□	252.5	237.5	180	37.5	60	135	5	8	0.66
40A365C□	365	350	315	30	52.5	270	8	14	0.93

\*: The values indicate the mass of moving coil with a hall sensor unit.



# External Dimensions Units: mm

- Moving Coil: SGLGW-40A□□□C□D (With a connector by Interconnectron GmbH)

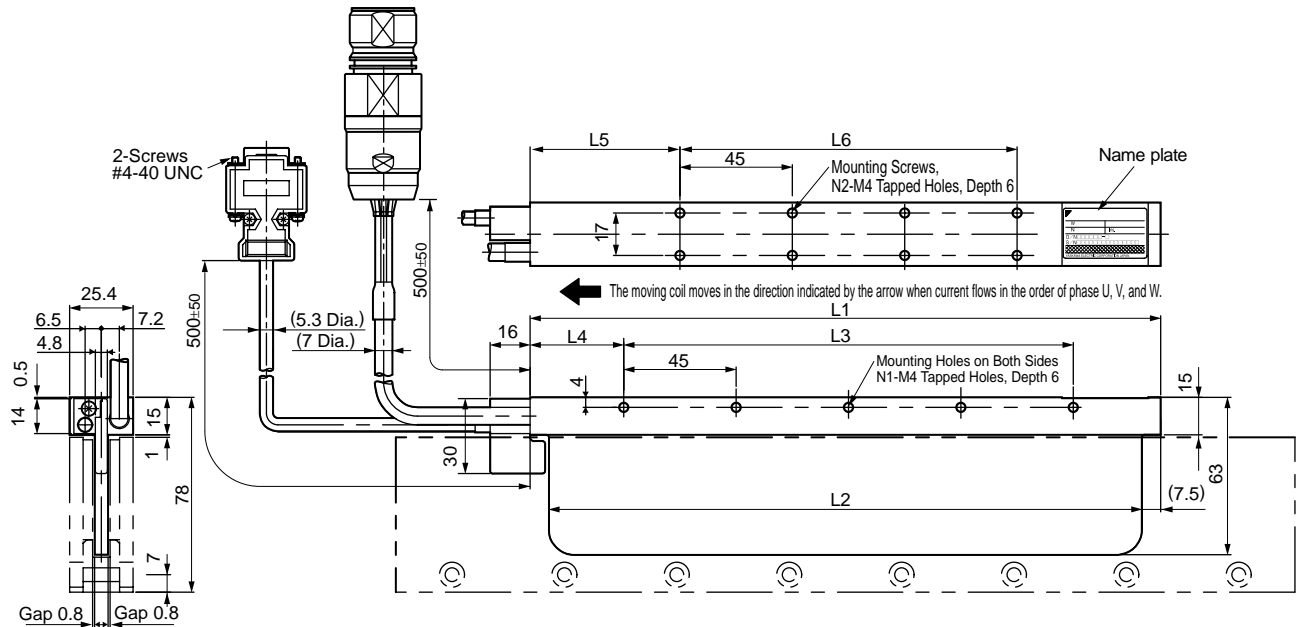

### Hall Sensor Connector Specifications

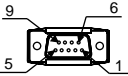

Pin Connector :  
17JE-23090-02 (D8C)  
by DDK Ltd.

The Mating Connector  
Socket Connector :  
17JE-13090-02 (D8C)  
Stud : 17L-002C or  
17L-002C1

Pin No.	Signal
1	+5V (Power supply)
2	Phase U
3	Phase V
4	Phase W
5	0V (Power supply)
6	Not used
7	Not used
8	Not used
9	Not used

### Linear Servomotor Connector Specifications

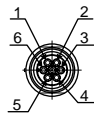

Extension: SROC06JM5CN169  
Pin : 021.423.1020  
by Interconnectron GmbH

The Mating Connector  
Plug : SPUC06KFSDN236  
Socket: 020.030.1020

Pin No.	Signal	Wire Color
1	Phase U	Red
2	Phase V	White
3	Phase W	Blue
4	Not used	-
5	Not used	-
6	FG	Green

### Hall Sensor Output Signals

When the moving coil moves in the direction indicated by the arrow in the figure, the relationship between the hall sensor output signals Su, Sv, Sw and the inverse power of each motor phase Vu, Vv, Vw becomes as shown in the figure below.

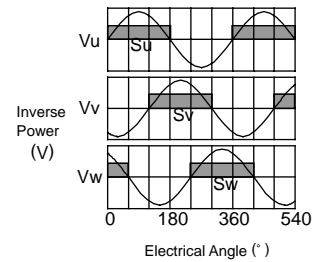

Moving Coil Model SGLGW-	L1	L2	L3	L4	L5	L6	N1	N2	Approx. Mass* kg
40A140C□D	140	125	90	30	52.5	45	3	4	0.40
40A253C□D	252.5	237.5	180	37.5	60	135	5	8	0.66
40A365C□D	365	350	315	30	52.5	270	8	14	0.93

\*: The values indicate the mass of moving coil with a hall sensor unit.

**External Dimensions** Units: mm

- Magnetic Way : SGLGM-40□□□C (Without mounting holes on the bottom)  
SGLGM-40□□□CT (With mounting holes on the bottom)

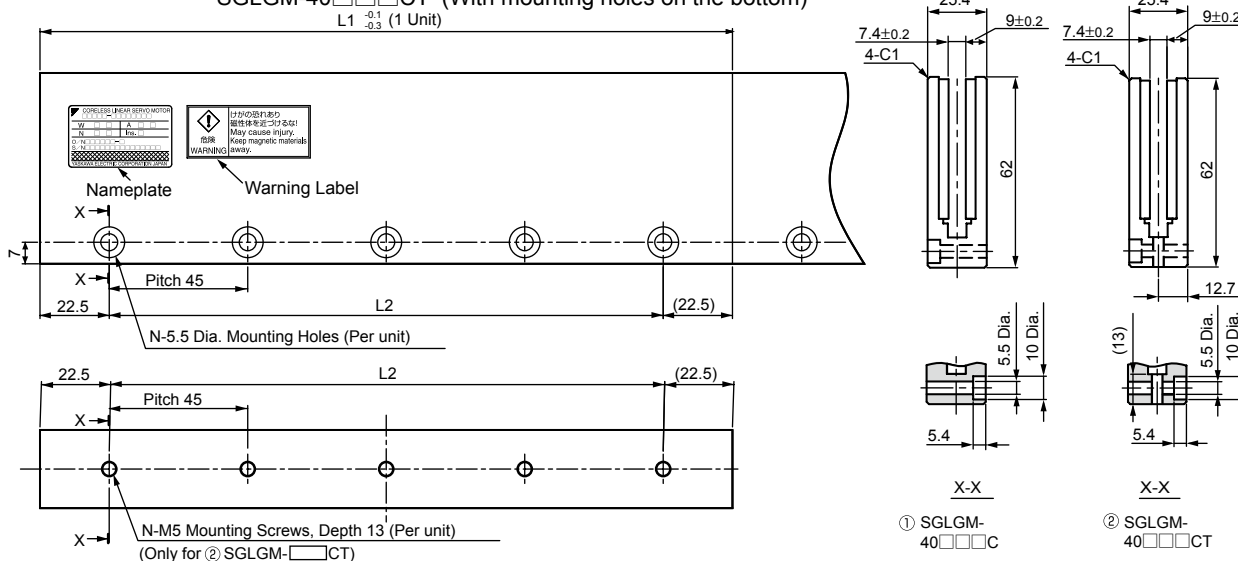

Type	Standard-force Magnetic Way Model SGLGM-	L1	L2	N	Approx. Mass kg
Standard Force	40090C or 40090CT	90	45	2	0.8
	40225C or 40225CT	225	180	5	2.0
	40360C or 40360CT	360	315	8	3.1
	40405C or 40405CT	405	360	9	3.5
	40450C or 40450CT	450	405	10	3.9

Note: If you have a pacemaker or any other electronic medical device, do not go near the magnetic way of the linear servomotor.

- High-force Magnetic Way : SGLGM-40□□□C-M (Without mounting holes on the bottom)  
SGLGM-40□□□CT-M (With mounting holes on the bottom)

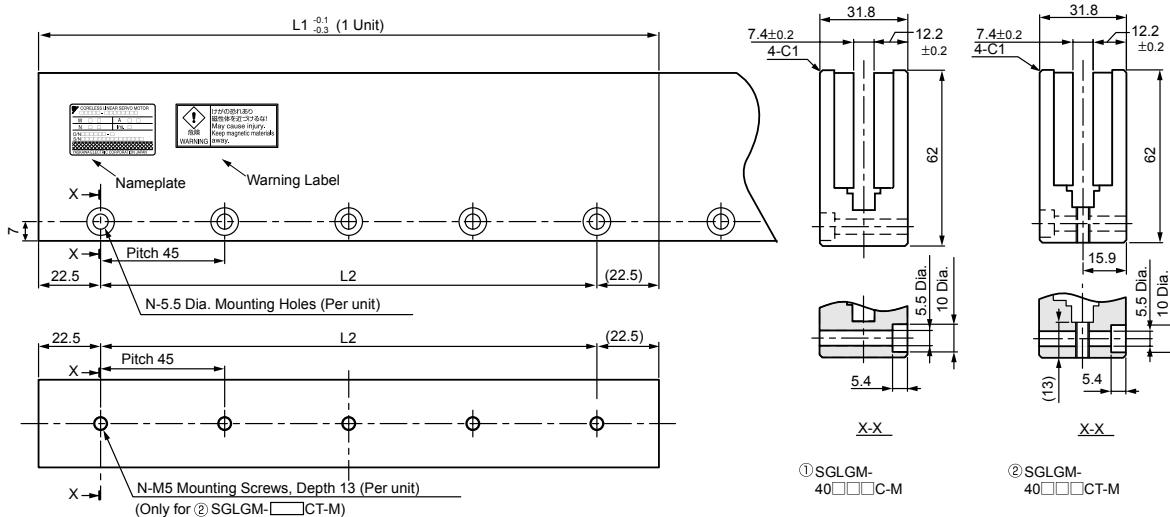

Type	High-force Magnetic Way Model SGLGM-	L1	L2	N	Approx. Mass kg
High Force	40090C-M or 40090CT-M	90	45	2	1.0
	40225C-M or 40225CT-M	225	180	5	2.6
	40360C-M or 40360CT-M	360	315	8	4.1
	40405C-M or 40405CT-M	405	360	9	4.6
	40450C-M or 40450CT-M	450	405	10	5.1

Note: If you have a pacemaker or any other electronic medical device, do not go near the magnetic way of the linear servomotor.

# External Dimensions Units: mm

## (3) SGLGW-60

- Moving Coil: SGLGW-60A□□□C□ (With a connector by Tyco Electronics AMP K.K.)

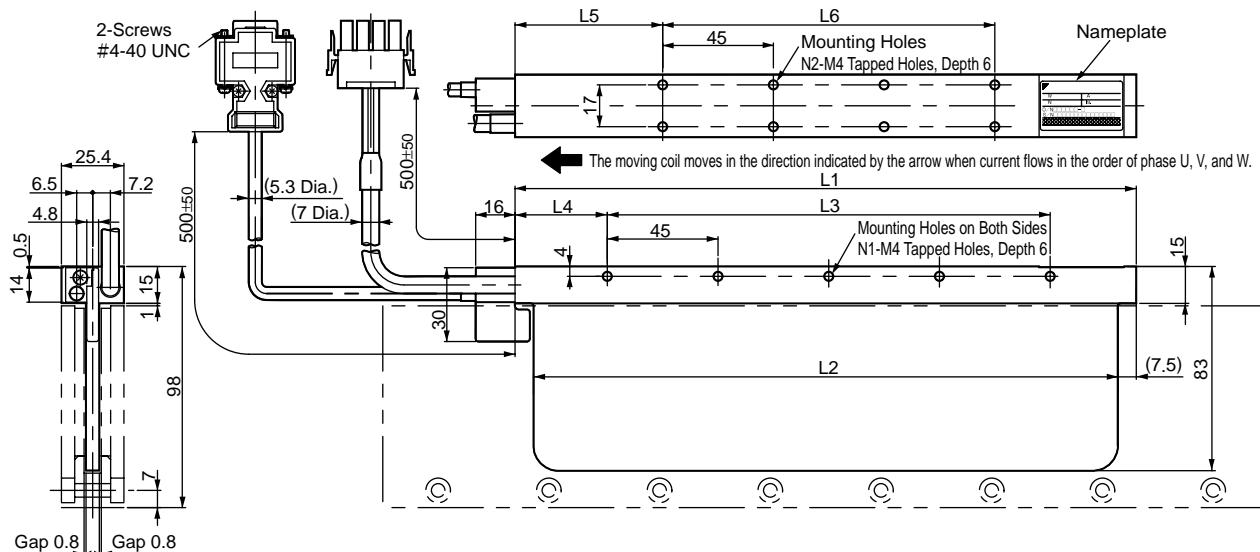

### Hall Sensor Connector Specifications

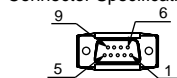

Pin Connector :  
17JE-23090-02 (D8C)  
by DDK Ltd.

### The Mating Connector

Socket Connector :  
17JE-13090-02 (D8C)  
Stud : 17L-002C or  
17L-002C1

Pin No.	Signal
1	+5V (Power supply)
2	Phase U
3	Phase V
4	Phase W
5	0V (Power supply)
6	Not used
7	Not used
8	Not used
9	Not used

### Linear Servomotor Connector Specifications

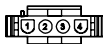

Plug : 350779-1  
Pin : 350561-3 or  
350690-3 (No.1 to 3)  
350654-1  
350669-1 (No.4)  
by Tyco Electronics AMP K.K.

### The Mating Connector

Cap : 350780-1  
Socket : 350570-3 or  
350689-3

Pin No.	Signal	Wire Color
1	Phase U	Red
2	Phase V	White
3	Phase W	Blue
4	FG	Green

### Hall Sensor Output Signals

When the moving coil moves in the direction indicated by the arrow in the figure, the relationship between the hall sensor output signals  $S_u$ ,  $S_v$ ,  $S_w$  and the inverse power of each motor phase  $V_u$ ,  $V_v$ ,  $V_w$  becomes as shown in the figure below.

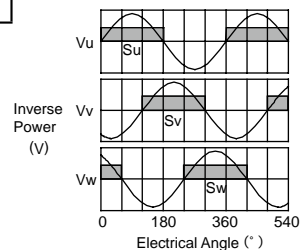

Moving Coil Model SGLGW-	L1	L2	L3	L4	L5	L6	N1	N2	Approx. Mass* kg
60A140C□	140	125	90	30	52.5	45	3	4	0.48
60A253C□	252.5	237.5	180	37.5	60	135	5	8	0.82
60A365C□	365	350	315	30	52.5	270	8	14	1.16

\*: The values indicate the mass of moving coil with a hall sensor unit.

**External Dimensions** Units: mm

- Moving Coil: SGLGW-60A□□□□D (With a connector by Interconnectron GmbH)

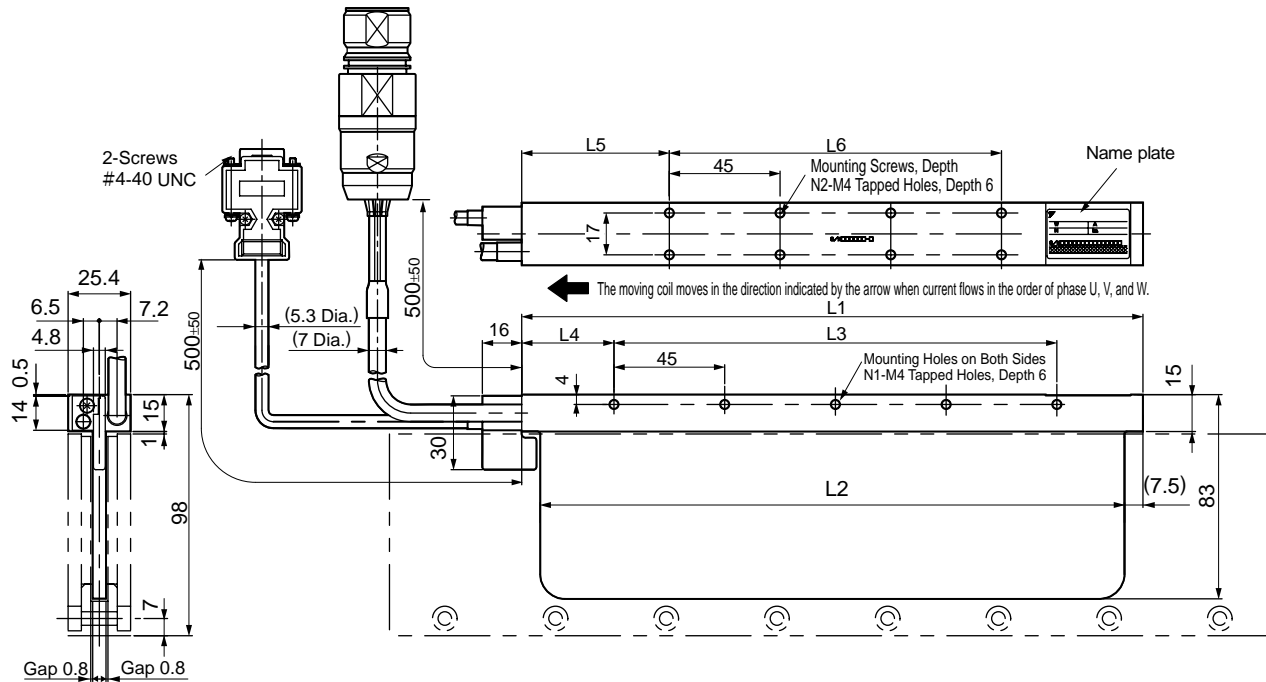

Hall Sensor Connector Specifications

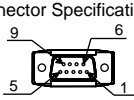

Pin Connector :  
17JE-23090-02 (D8C)  
by DDK Ltd.

The Mating Connector  
Socket Connector :  
17JE-13090-02 (D8C)  
Stud : 17L-002C or  
17L-002C1

Pin No.	Signal
1	+5V (Power supply)
2	Phase U
3	Phase V
4	Phase W
5	0V (Power supply)
6	Not used
7	Not used
8	Not used
9	Not used

Linear Servomotor Connector Specifications

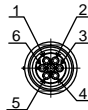

Extension: SROC06JMSCN169  
Pin : 021.423.1020  
by Interconnectron GmbH

The Mating Connector  
Plug : SPUC06KFSDN236  
Socket: 020.030.1020

Pin No.	Signal	Wire Color
1	Phase U	Red
2	Phase V	White
3	Phase W	Blue
4	Not used	-
5	Not used	-
6	FG	Green

Hall Sensor Output Signals

When the moving coil moves in the direction indicated by the arrow in the figure, the relationship between the hall sensor output signals Su, Sv, Sw and the inverse power of each motor phase Vu, Vv, Vw becomes as shown in the figure below.

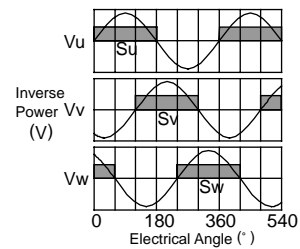

Moving Coil Model SGLGW-	L1	L2	L3	L4	L5	L6	N1	N2	Approx. Mass* kg
60A140C□□D	140	125	90	30	52.5	45	3	4	0.48
60A253C□□D	252.5	237.5	180	37.5	60	135	5	8	0.82
60A365C□□D	365	350	315	30	52.5	270	8	14	1.16

\*: The values indicate the mass of moving coil with a hall sensor unit.

# External Dimensions Units: mm

- Magnetic Way : SGLGM-60□□□C (Without mounting holes on the bottom)  
SGLGM-60□□□CT (With mounting holes on the bottom)

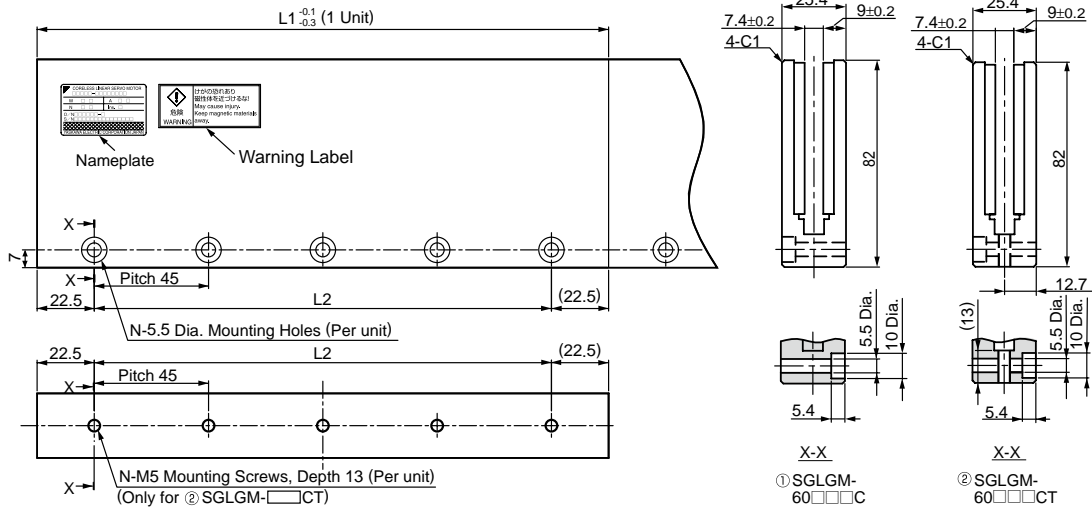

Type	Standard-force Magnetic Way Model SGLGM-	L1	L2	N	Approx. Mass kg
Standard Force	60090C or 60090CT	90	45	2	1.1
	60225C or 60225CT	225	180	5	2.6
	60360C or 60360CT	360	315	8	4.1
	60405C or 60405CT	405	360	9	4.6
	60450C or 60450CT	450	405	10	5.1

Note: If you have a pacemaker or any other electronic medical device, do not go near the magnetic way of the linear servomotor.

- High-force Magnetic Way : SGLGM-60□□□C-M (Without mounting holes on the bottom)  
SGLGM-60□□□CT-M (With mounting holes on the bottom)

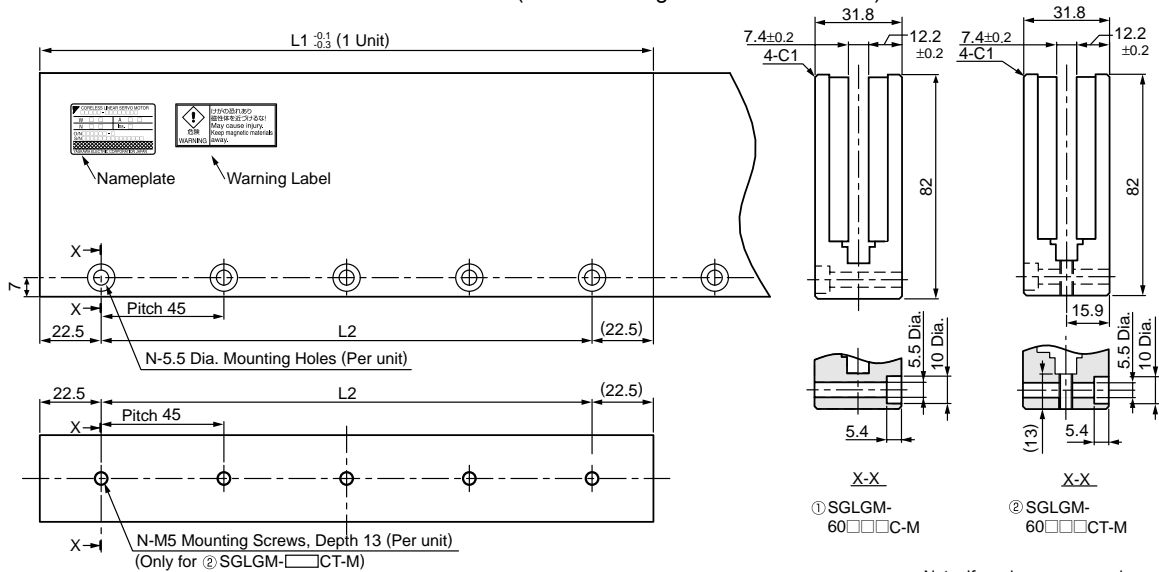

Type	High-force Magnetic Way Model SGLGM-	L1	L2	N	Approx. Mass kg
High Force	60090C-M or 60090CT-M	90	45	2	1.3
	60225C-M or 60225CT-M	225	180	5	3.3
	60360C-M or 60360CT-M	360	315	8	5.2
	60405C-M or 60405CT-M	405	360	9	5.9
	60450C-M or 60450CT-M	450	405	10	6.6

Note: If you have a pacemaker or any other electronic medical device, do not go near the magnetic way of the linear servomotor.

**External Dimensions** Units: mm

(4) SGLGW-90

- Moving Coil: SGLGW-90A□□□□□ (With a connector by Tyco Electronics AMP K.K.)

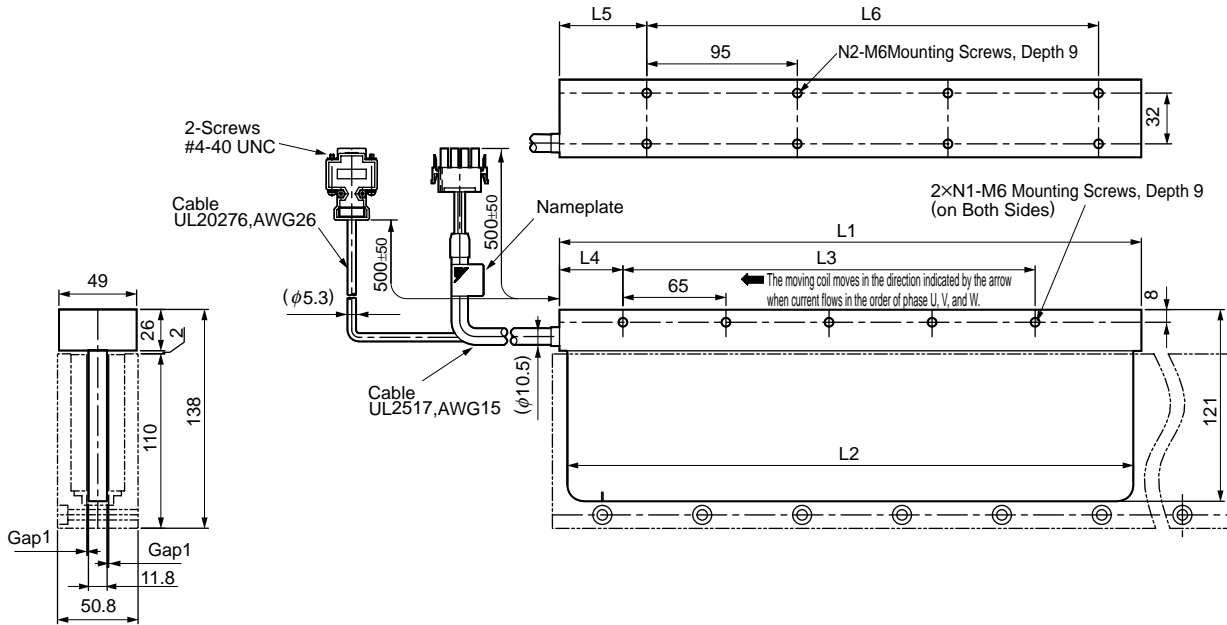

Hall Sensor Connector Specifications

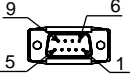

Pin Connector :  
17JE-23090-02 (D8C)  
by DDK Ltd.

The Mating Connector

Socket Connector :  
17JE-13090-02 (D8C)  
Stud : 17L-002C or  
17L-002C1

Pin No.	Signal
1	+5V (Power supply)
2	Phase U
3	Phase V
4	Phase W
5	0V (Power supply)
6	Not used
7	Not used
8	Not used
9	Not used

Linear Servomotor Connector Specifications

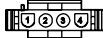

Plug : 350779-1  
Pin : 350218-3 or  
350547-3 (No.1 or 3)  
350654-1  
350669-1 (No.4)  
by Tyco Electronics AMP K.K.

The Mating Connector

Cap : 350780-1  
Socket : 350536-3 or  
350550-3

Pin No.	Signal	Wire Color
1	Phase U	Red
2	Phase V	White
3	Phase W	Blue
4	FG	Green

Hall Sensor Output Signals

When the moving coil moves in the direction indicated by the arrow in the figure, the relationship between the hall sensor output signals Su, Sv, Sw and the inverse power of each motor phase Vu, Vv, Vw becomes as shown in the figure below.

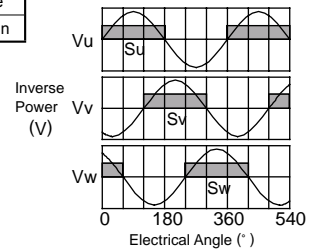

Moving Coil Model SGLGW-	L1	L2	L3	L4	L5	L6	N1	N2	Approx. Mass* kg
90A200C□	199	189	130	40	60	95	3	4	2.2
90A370C□	367	357	260	40	55	285	5	8	3.65
90A535C□	535	525	455	40	60	380	8	10	4.95

\*: The values indicate the mass of moving coil with a hall sensor unit.

**External Dimensions** Units: mm

- Magnetic Way: SGLGM-90□□□A

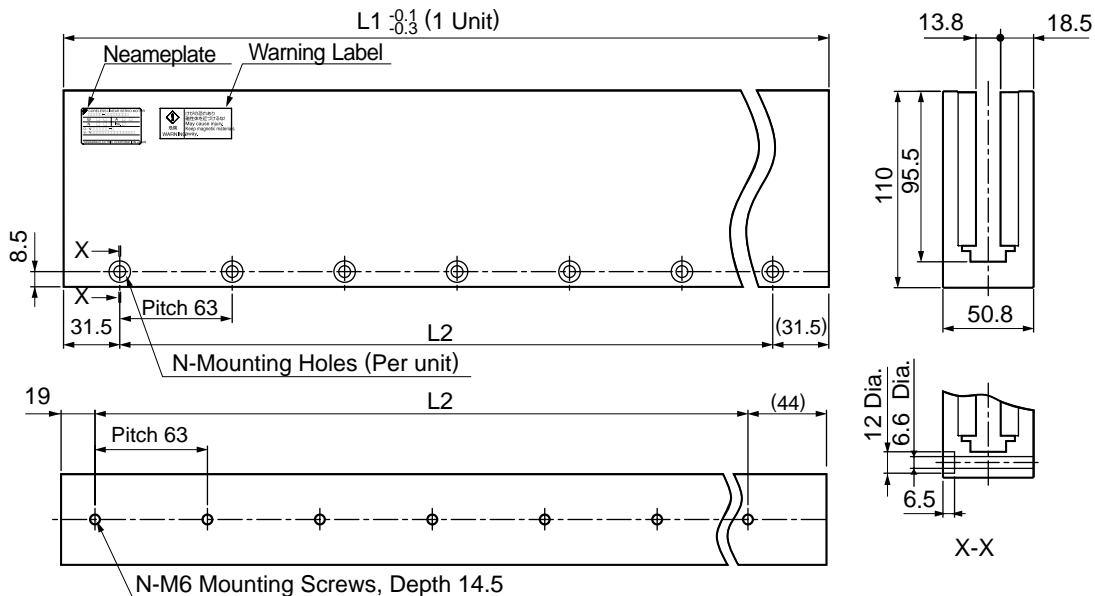

Magnetic Way SGLGM-	L1	L2	N	Approx. Mass kg
90252A	252	189	4	7.3
90504A	504	441	8	14.7

Note: If you have a pacemaker or any other electronic medical device, do not go near the magnetic way of the linear servomotor.

Selecting Cables

● Cables Connections

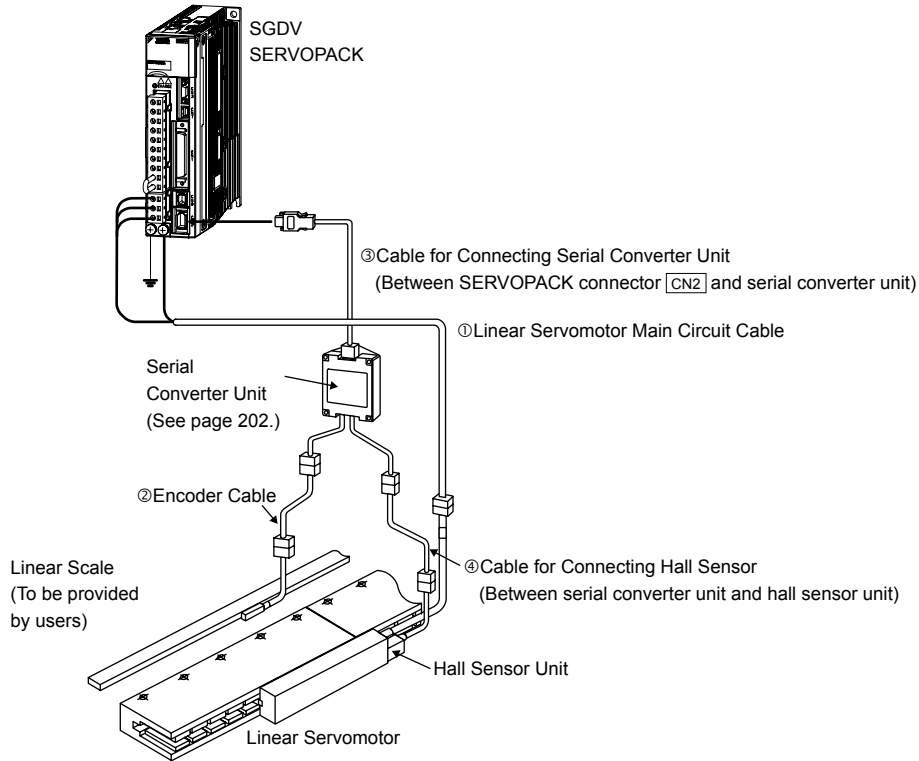

● Cables

Name	Applicable Linear Servomotor Model	Length	Order No.	Specifications	Details
① Linear Servomotor Main Circuit Cables	SGLGW-30,-40,-60	1 m	JZSP-CLN11-01-E	SERVOPACK End      Linear Servomotor End 	(1)
		3 m	JZSP-CLN11-03-E		
		5 m	JZSP-CLN11-05-E		
		10 m	JZSP-CLN11-10-E		
		15 m	JZSP-CLN11-15-E		
	20 m	JZSP-CLN11-20-E			
	SGLGW-90	1 m	JZSP-CLN21-01-E	SERVOPACK End      Linear Servomotor End 	(2)
		3 m	JZSP-CLN21-03-E		
		5 m	JZSP-CLN21-05-E		
		10 m	JZSP-CLN21-10-E		
		15 m	JZSP-CLN21-15-E		
	20 m	JZSP-CLN21-20-E			
	SGLGW -30□□□□□□D -40□□□□□□D -60□□□□□□D	1 m	JZSP-CLN14-01-E	SERVOPACK End      Linear Servomotor End 	(3)
		3 m	JZSP-CLN14-03-E		
		5 m	JZSP-CLN14-05-E		
10 m		JZSP-CLN14-10-E			
15 m		JZSP-CLN14-15-E			
20 m	JZSP-CLN14-20-E				

\*1: Connector by Tyco Electronics AMP K.K.

\*2: Connector by Interconnectron GmbH

(Cont'd)

NOTE: Shaded items are non-stock.



# Selecting Cables

## ● Cables

Name	Applicable Linear Servomotor Model	Length	Order No.	Specifications	Details
② Cables for Connecting Linear Scales*	All models	1 m	JZSP-CLL00-01-E		(4)
		3 m	JZSP-CLL00-03-E		
		5 m	JZSP-CLL00-05-E		
		10 m	JZSP-CLL00-10-E		
		15 m	JZSP-CLL00-15-E		
③ Cables for Connecting Serial Converter Units	All models	1 m	JZSP-CLP70-01-E		(5)
		3 m	JZSP-CLP70-03-E		
		5 m	JZSP-CLP70-05-E		
		10 m	JZSP-CLP70-10-E		
		15 m	JZSP-CLP70-15-E		
		20 m	JZSP-CLP70-20-E		
④ Cables for Connecting Hall Sensors	All models	1 m	JZSP-CLL10-01-E		(6)
		3 m	JZSP-CLL10-03-E		
		5 m	JZSP-CLL10-05-E		
		10 m	JZSP-CLL10-10-E		
		15 m	JZSP-CLL10-15-E		

\* When using the serial converter unit, JZDP-G00□-□□□-E, the maximum cable length is 3 m.

### (1) Linear Servomotor Main Circuit Cables: JZSP-CLN11-□□-E

### · Wiring Specifications

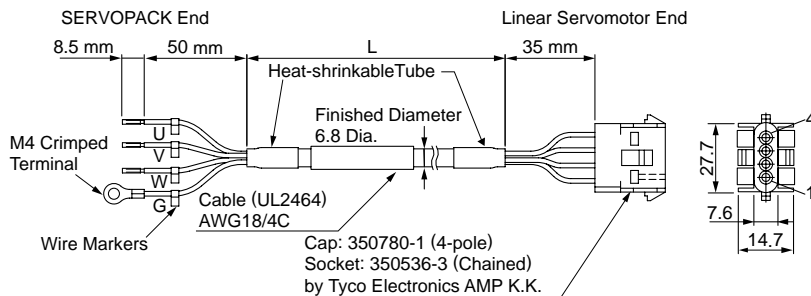

SERVOPACK-end Leads		Linear Servomotor-end Connector	
Wire Color	Signal	Signal	Pin. No.
Red	Phase U	Phase U	1
White	Phase V	Phase V	2
Blue	Phase W	Phase W	3
Green/yellow	FG	FG	4

### (2) Linear Servomotor Main Circuit Cables: JZSP-CLN21-□□-E

### · Wiring Specifications

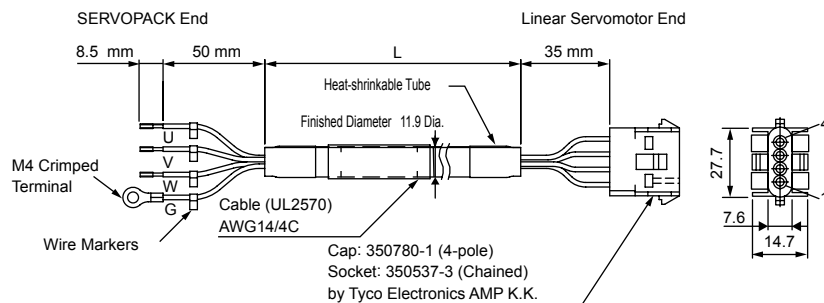

SERVOPACK-end Leads		Linear Servomotor-end Connector	
Wire Color	Signal	Signal	Pin. No.
Red	Phase U	Phase U	1
White	Phase V	Phase V	2
Blue	Phase W	Phase W	3
Green/yellow	FG	FG	4

### (3) Linear Servomotor Main Circuit Cables: JZSP-CLN14-□□-E

### · Wiring Specifications

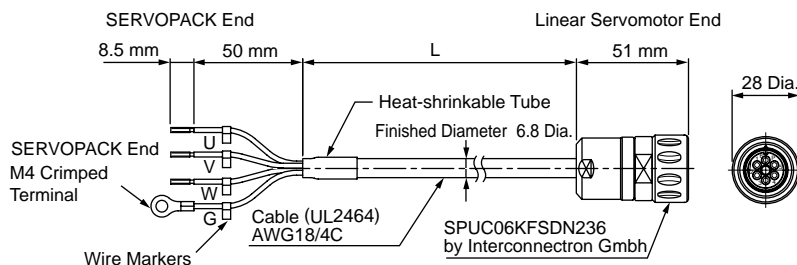

SERVOPACK-end Leads		Linear Servomotor-end Connector	
Wire Color	Signal	Signal	Pin No.
Black (White 1)	Phase U	Phase U	1
Black (White 2)	Phase V	Phase V	2
Black (White 3)	Phase W	Phase W	3
Green/yellow	FG	—	4
		—	5
		FG	6

Selecting Cables

(4) Cables for Connecting Linear Scales: JZSP-CLL00-□□-E

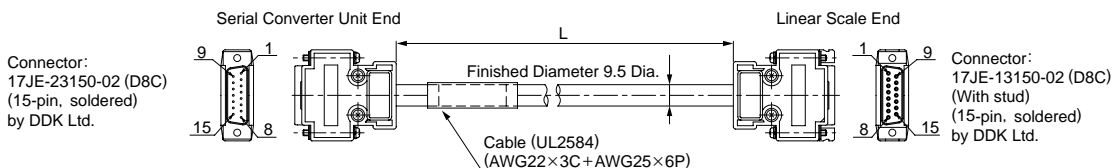

· Wiring Specifications

Serial Converter Unit End		Linear Scale End	
Pin No.	Signal	Pin No.	Signal
1	/Cos (V1-)	1	/Cos (V1-)
2	/Sin (V2-)	2	/Sin (V2-)
3	Ref (V0+)	3	Ref (V0+)
4	+5V	4	+5V
5	5Vs	5	5Vs
6	BID	6	BID
7	Vx	7	Vx
8	Vq	8	Vq
9	Cos (V1+)	9	Cos (V1+)
10	Sin (V2+)	10	Sin (V2+)
11	/Ref (V0-)	11	/Ref (V0-)
12	0V	12	0V
13	0Vs	13	0Vs
14	DIR	14	DIR
15	Inner	15	Inner
Case	Shield	Case	Shield

(5) Cables for Connecting Serial Converter Units: JZSP-CLP70-□□-E

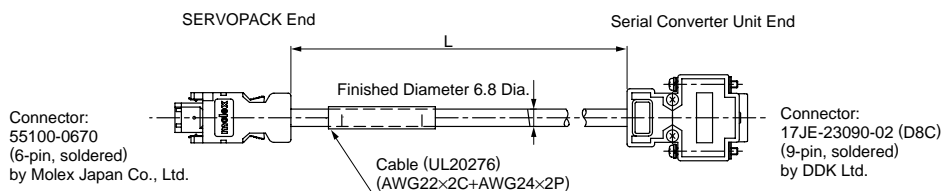

· Wiring Specifications

SERVOPACK End			Serial Converter Unit End		
Pin No.	Signal	Wire Color	Pin No.	Signal	Wire Color
1	PG5V	Red	1	+5V	Red
2	PG0V	Black	5	0V	Black
3	-	-	3	-	-
4	-	-	4	-	-
5	PS	Light blue	2	Phase S output	Light blue
6	/PS	Light blue/white	6	Phase /S output	Light blue/white
Shell	Shield	-	Case	Shield	-
			7	-	-
			8	-	-
			9	-	-

(6) Cables for Connecting Hall Sensors: JZSP-CLL10-□□-E

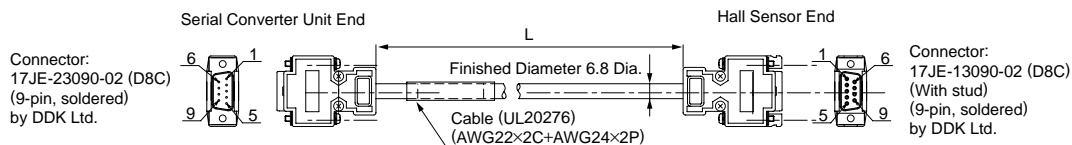

· Wiring Specifications

Serial Converter Unit End		Hall Sensor End	
Pin No.	Signal	Pin No.	Signal
1	+5V	1	+5V
2	Phase U input	2	Phase U input
3	Phase V input	3	Phase V input
4	Phase W input	4	Phase W input
5	0V	5	0V
6	-	6	-
7	-	7	-
8	-	8	-
9	-	9	-
Case	Shield	Case	Shield

# Linear Servomotors

# SGLFW

(With F-type iron core)

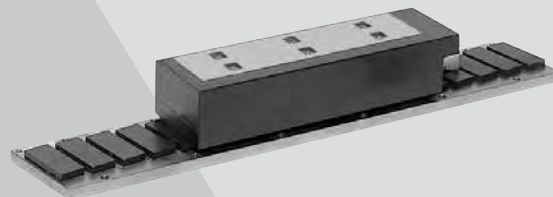

## Model Designations

### ● Moving Coil

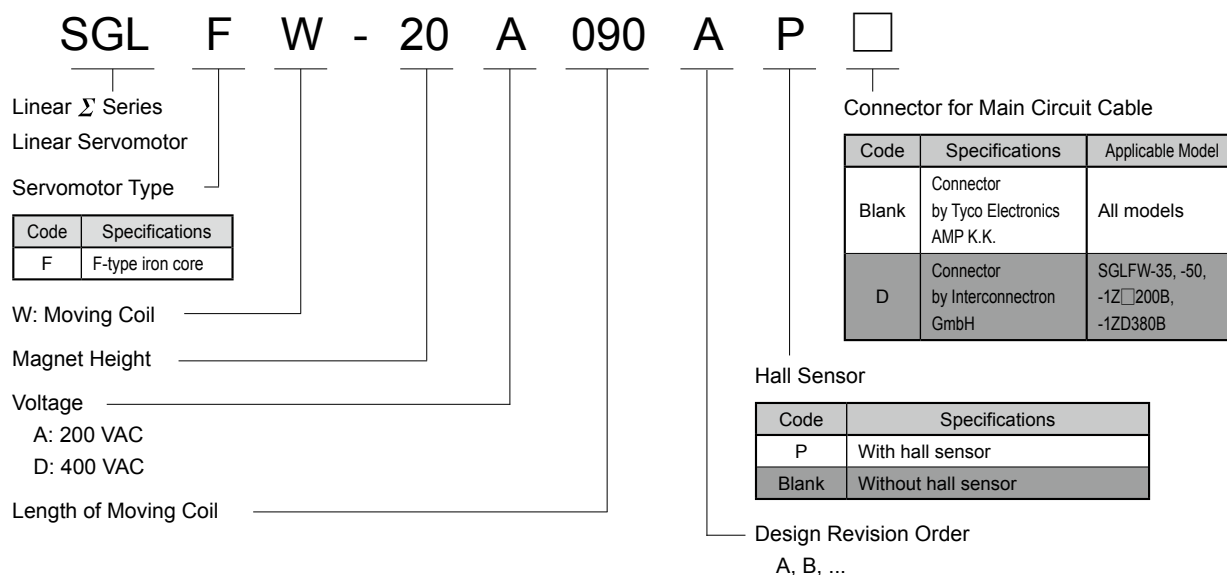

### ◦Magnetic Way

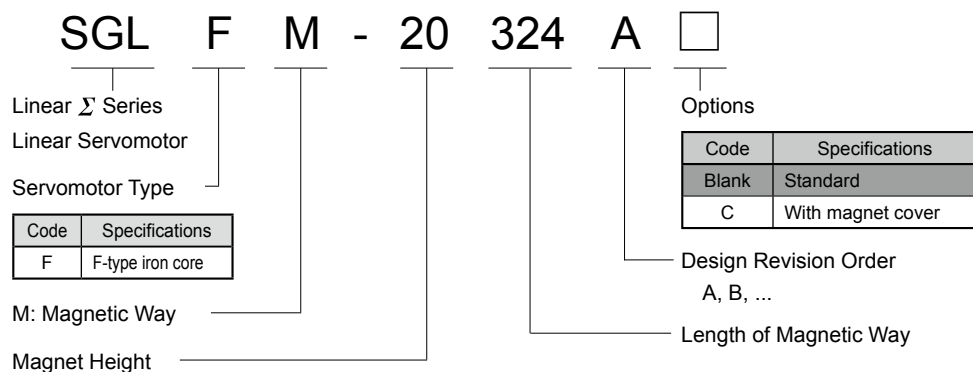

NOTE: Shaded items are non-stock.

- Direct-feed mechanism for high-speed and high-precision positioning.
- The magnetic attraction force between the moving and stationary members can be used effectively to increase the rigidity of the linear guidance by preloading the linear motion bearings.
- The magnetic preloading on certain types of compliant linear motion bearings can help increase the system's frequency response, improving its deceleration and settling performances.

- Feeders and loaders
- Semiconductor equipment
- LCD manufacturing equipment

● Precautions on Moving Coil with Hall Sensor

When using a moving coil with a hall sensor, the magnetic way must completely cover the bottom of the hall sensor. Refer to the example showing the correct installation.

When determining the length of the moving coil's stroke or the length of the magnetic way, consider the total length of the moving coil and the hall sensor unit. Refer to the following table.

<Correct>

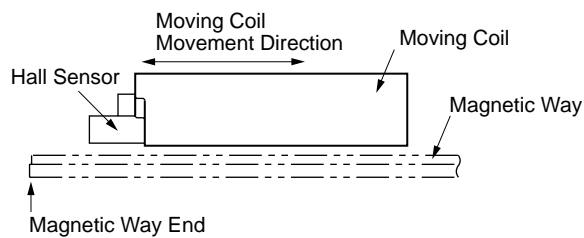

<Incorrect>

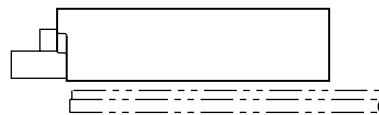

The total length of moving coil with hall sensor

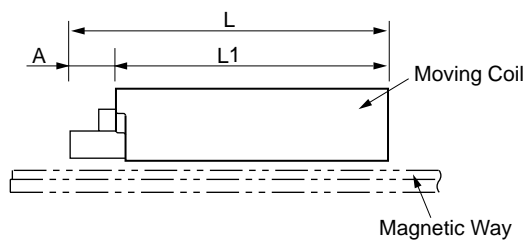

Moving Coil Model SGLFW-	Length of Moving Coil L1 (mm)	Length of Hall Sensor Unit A (mm)	Total Length L (mm)
20A090AP□	91	22	113
20A120AP□	127		149
35□120AP□	127	22	149
35□230AP□	235		257
50□200□P□	215	22	237
50□380□P□	395		417
12□200□P□	215	22	237
12□380□P□	395		417

## Ratings and Specifications

Time Rating: Continuous

Insulation Resistance: 500 VDC, 10 MΩ min.

Ambient Temperature: 0 to 40°C

Excitation: Permanent magnet

Withstand Voltage: 1500 VAC for one minute

Enclosure: Self-cooled

Ambient Humidity: 20% to 80% (no condensation)

Allowable Winding Temperature: 130°C (Thermal class B)

### 200-V Class

Linear Servomotor Model SGLFW- <span style="border: 1px solid black; padding: 0 5px;"> </span>		20A		35A		50A		1ZA	
		090A	120A	120A	230A	200B	380B	200B	380B
Peak Speed	m/s	5.0	5.0	5.0	5.0	5.0	5.0	4.9	4.9
Rated Force*	N	25	40	80	160	280	560	560	1120
Rated Current*	$A_{rms}$	0.70	0.80	1.4	2.8	5.0	10.0	8.7	17.5
Peak Force*	N	86	125	220	440	600	1200	1200	2400
Peak Current*	$A_{rms}$	3.0	2.9	4.4	8.8	12.4	25.0	21.6	43.6
Moving Coil Mass	kg	0.7	0.9	1.3	2.3	3.5	6.9	6.4	11.5
Force Constant	$N/A_{rms}$	36.0	54.0	62.4	62.4	60.2	60.2	69.0	69.0
BEMF Constant	$V/(m/s)$	12.0	18.0	20.8	20.8	20.1	20.1	23.0	23.0
Motor Constant	$N/\sqrt{W}$	7.9	9.8	14.4	20.4	34.3	48.5	52.4	74.0
Electrical Time Constant	ms	3.2	3.3	3.6	3.6	15.9	15.8	18.3	18.3
Mechanical Time Constant	ms	11.0	9.3	6.2	5.5	3.0	2.9	2.3	2.1
Thermal Resistance (With Heat Sink)	K/W	4.35	3.19	1.57	0.96	0.56	0.38	0.47	0.2
Thermal Resistance (Without Heat Sink)	K/W	7.69	5.02	4.10	1.94	1.65	0.95	1.3	0.73
Magnetic Attraction	N	314	462	809	1590	1650	3260	3300	6520
Applicable SERVOPACK	SGDV-	1R6	1R6	1R6	3R8	5R5	120A	120A	200A

Notes: 1 The items marked with an \* and Force and Speed Characteristics (the table on the next page) are the values at a motor winding temperature of 100°C during operation in combination with a SERVOPACK. The others are at 20°C.

2 The above specifications show the values under the cooling condition when a heat sink (aluminum board) listed in the following table is mounted on the moving coil.

Heat Sink Size	
125 mm × 125 mm × 13 mm	SGLFW-20A090A, -20A120A
254 mm × 254 mm × 25 mm	SGLFW-35A120A, -35A230A
400 mm × 500 mm × 40 mm	SGLFW-50A200B, -50A380B, -1ZA200B
600 mm × 762 mm × 50 mm	SGLFW-1ZA380B

### 400-V Class

Linear Servomotor Model SGLFW- <span style="border: 1px solid black; padding: 0 5px;"> </span>		35D		50D		1ZD	
		120A	230A	200B	380B	200B	380B
Peak Speed	m/s	4.5	4.5	5.0	5.0	5.0	5.0
Rated Force*	N	80	160	280	560	560	1120
Rated Current*	$A_{rms}$	0.6	1.3	2.3	4.5	4.9	9.8
Peak Force*	N	220	440	600	1200	1200	2400
Peak Current*	$A_{rms}$	2.0	4.0	5.6	11.0	12.3	24.6
Moving Coil Mass	kg	1.3	2.3	3.5	6.9	6.4	11.5
Force Constant	$N/A_{rms}$	136.0	136.0	134.7	134.7	122.6	122.6
BEMF Constant	$V/(m/s)$	45.3	45.3	44.9	44.9	40.9	40.9
Motor Constant	$N/\sqrt{W}$	14.2	20.1	33.4	47.2	51.0	72.1
Electrical Time Constant	ms	3.7	3.6	15.0	15.0	17.4	17.2
Mechanical Time Constant	ms	5.2	5.1	3.2	3.2	2.5	2.2
Thermal Resistance (With Heat Sink)	K/W	1.57	0.96	0.56	0.38	0.47	0.2
Thermal Resistance (Without Heat Sink)	K/W	4.1	1.94	1.65	0.95	1.3	0.73
Magnetic Attraction	N	810	1590	1650	3260	3300	6520
Applicable SERVOPACK	SGDV-	1R9D	1R9D	3R5D	5R4D	5R4D	120D

Notes: 1 The items marked with an \* and Force and Speed Characteristics (the table on the next page) are the values at a motor winding temperature of 100°C during operation in combination with a SERVOPACK. The others are at 20°C.

2 The above specifications show the values under the cooling condition when a heat sink (aluminum board) listed in the following table is mounted on the moving coil.

Heat Sink Size	
254 mm × 254 mm × 25 mm	SGLFW-35D120A, -35D230A
400 mm × 500 mm × 40 mm	SGLFW-50D200B, -50D380B, -1ZD200B
600 mm × 762 mm × 50 mm	SGLFW-1ZD380B

**Ratings and Specifications**

● **Force and Speed Characteristics** **A** : Continuous Duty Zone **B** : Intermittent Duty Zone (Note<sup>1</sup>)

200-V Class

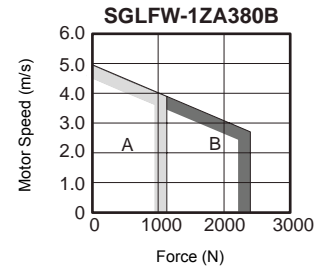
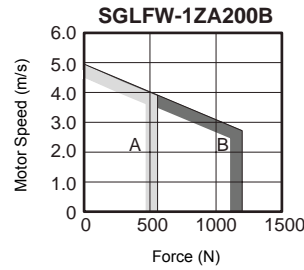
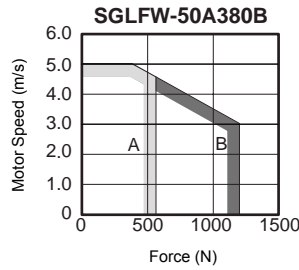
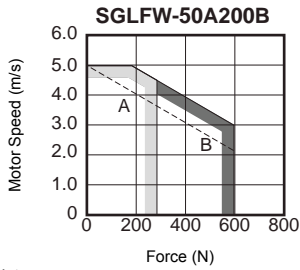
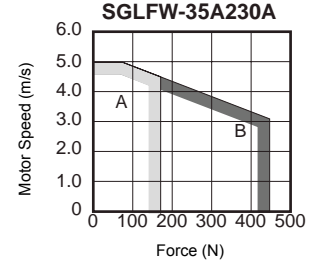
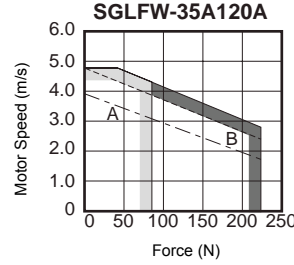
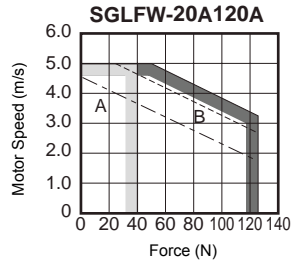
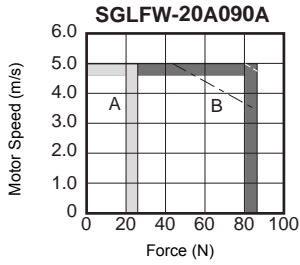

Notes:

- When the effective force during intermittent duty is within the rated force, the servomotor can be used within the intermittent duty zone.
- The solid, dotted, and dashed-dotted lines of the intermittent duty zone indicate the characteristics when a servomotor runs with the following combinations:
  - The solid line: With a three-phase 200 V or a single-phase 230 V SERVOPACK
  - The dotted line: With a single-phase 200 V SERVOPACK
  - The dashed-dotted line: With a single-phase 100 V SERVOPACK

400-V Class

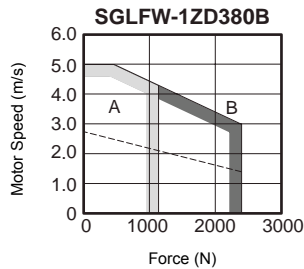
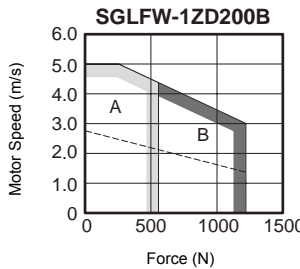
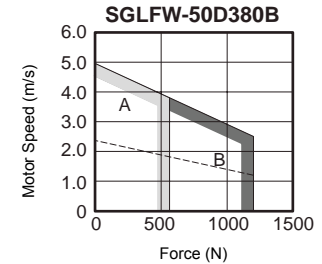
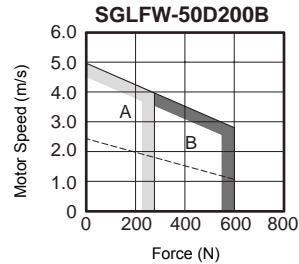
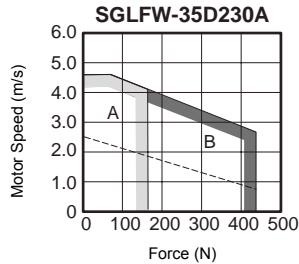
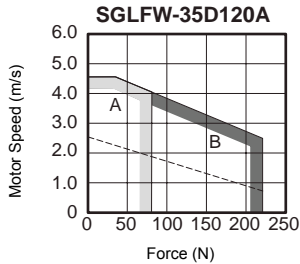

Notes:

- When the effective force during intermittent duty is within the rated force, the servomotor can be used within the intermittent duty zone.
- The dotted line indicates the characteristics when a 400-VAC linear servomotor is used with 200-V input power supply. In this case, a serial converter unit is required. Contact your Yaskawa representative for details.

● **Mechanical Specifications**

(1) Impact Resistance

- Impact acceleration: 196 m/s<sup>2</sup>
- Impact occurrences: twice

(2) Vibration Resistance

- The linear servomotors will withstand the following vibration acceleration in three directions: Vertical, side to side, and front to back.
- Vibration acceleration: 49 m/s<sup>2</sup>

# External Dimensions Units: mm

## (1) SGLFW-20

- Moving Coil: SGLFW-20A□□□A□ (With a connector by Tyco Electronics AMP K.K.)

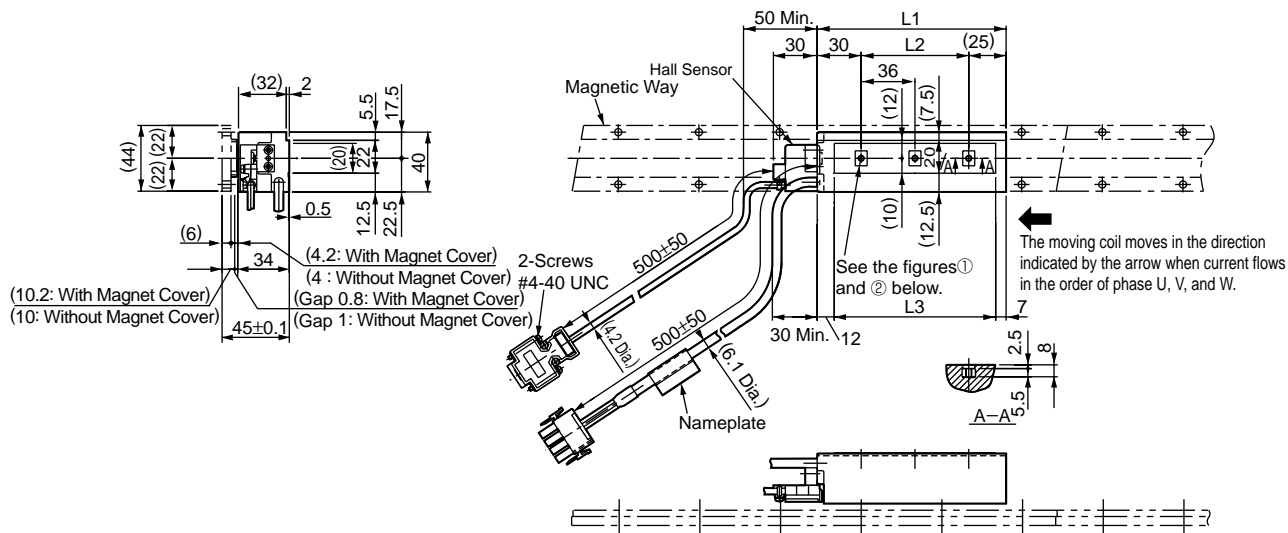

① SGLFW-20A090A□

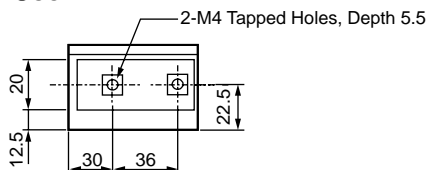

② SGLFW-20A120A□

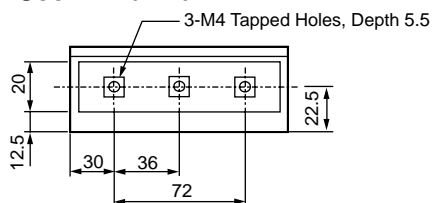

### Hall Sensor Connector Specifications

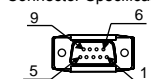

Pin Connector :  
17JE-13090-02 (D8C)  
by DDK Ltd.

### The Mating Connector

Socket Connector:  
17JE-13090-02 (D8C)  
Stud: 17L-002C or  
17L-002C1

Pin No.	Signal
1	+5V (Power supply)
2	Phase U
3	Phase V
4	Phase W
5	0V (Power supply)
6	Not used
7	Not used
8	Not used
9	Not used

### Linear Servomotor Connector Specifications



Plug: 350779-1  
Pin : 350218-3 or  
350547-3 (No.1 to 3)  
350654-1  
350669-1 (No.4)  
by Tyco Electronics AMP K.K.

### The Mating Connector

Cap : 350780-1  
Socket: 350536-3 or  
350550-3

Note: Models compatible with connectors by Interconnection GmbH are also available.

### Hall Sensor Output Signals

When the moving coil moves in the direction indicated by the arrow in the figure, the relationship between the hall sensor output signals  $S_u$ ,  $S_v$ ,  $S_w$  and the inverse power of each motor phase  $V_u$ ,  $V_v$ ,  $V_w$  becomes as shown in the figure below.

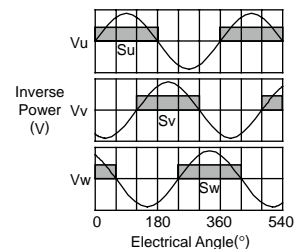

Moving Coil Model SGLFW-	L1	L2	L3	Approx. Mass kg
20A090A□	91	36	72	0.7
20A120A□	127	72	108	0.9

**External Dimensions** Units: mm

- Magnetic Way: SGLFM-20□□□A

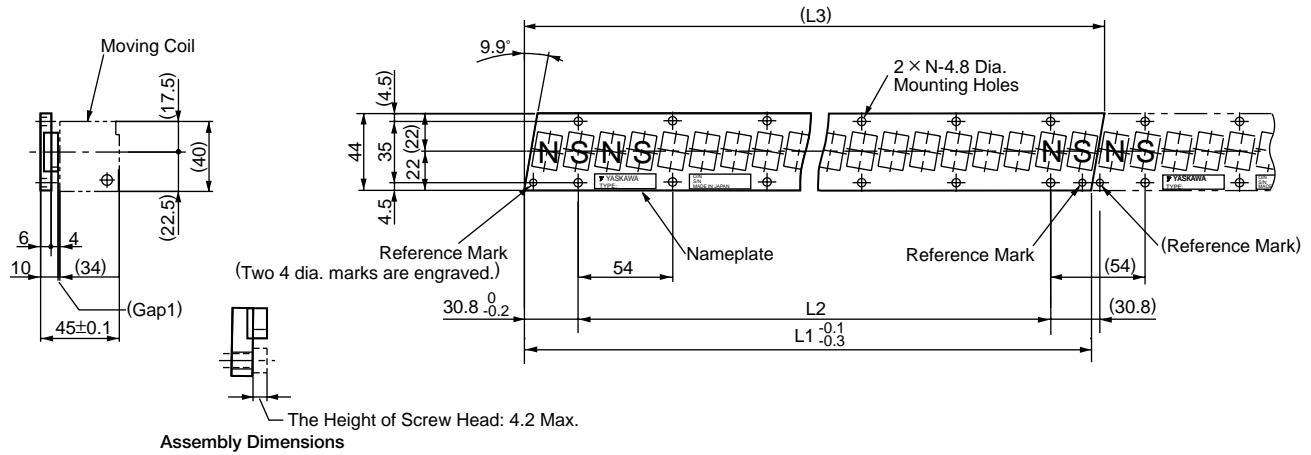

- Notes:
- 1 Multiple SGLFM-20□□□A magnetic ways can be connected. Connect magnetic ways so that the reference marks match one on the other in the same direction as shown in the figure.
  - 2 If you have a pacemaker or any other electronic medical device, do not go near the magnetic way of the linear servomotor.

Magnetic Way Model SGLFM-	L1 <sup>-0.1</sup> <sub>-0.3</sub>	L2	(L3)	N	Approx. Mass kg
20324A	324	270 (54 × 5)	(331.6)	6	0.9
20540A	540	486 (54 × 9)	(547.6)	10	1.4
20756A	756	702 (54 × 13)	(763.6)	14	2



# External Dimensions Units: mm

## (2) SGLFW-35

- Moving Coil: SGLFW-35□□□□A□ (With a connector by Tyco Electronics AMP K.K.)

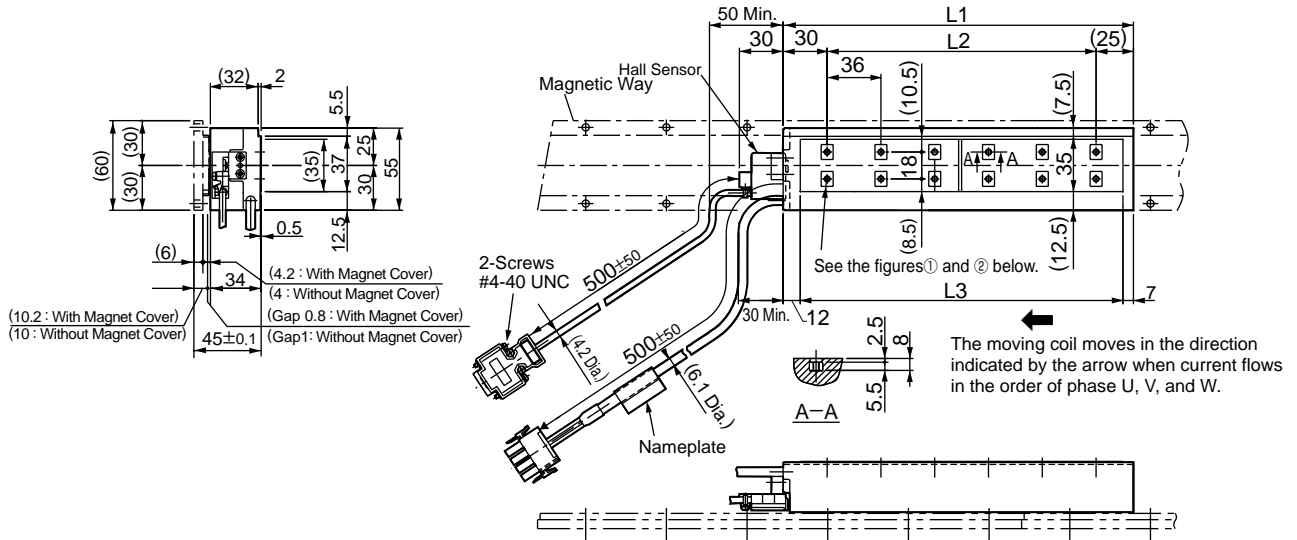

① SGLFW-35□120A□

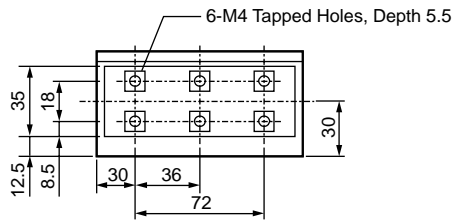

② SGLFW-35□230A□

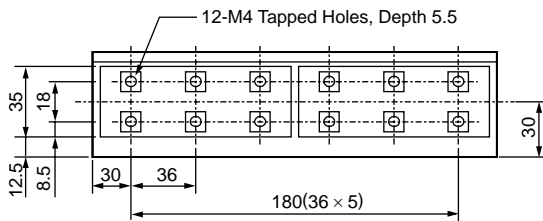

### Hall Sensor Connector Specifications

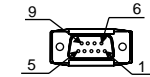

Pin Connector  
17JE-23090-02 (D8C)  
by DDK Ltd.

### The Mating Connector

Socket Connector:  
17JE-13090-02(D8C)  
Stud: 17L-002C or  
17L-002C1

Pin No.	Signal
1	+5V (Power supply)
2	Phase U
3	Phase V
4	Phase W
5	0V (Power supply)
6	Not used
7	Not used
8	Not used
9	Not used

### Linear Servomotor Connector Specifications

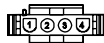

Plug: 350779-1  
Pin : 350218-3 or  
350547-3 (No.1 to 3)  
350654-1  
350669-1 (No.4)  
by Tyco Electronics AMP K.K.

### The Mating Connector

Cap : 350780-1  
Socket: 350536-3 or  
350550-3

Pin No.	Signal	Wire Color
1	Phase U	Red
2	Phase V	White
3	Phase W	Black
4	FG	Green

### Hall Sensor Output Signals

When the moving coil moves in the direction indicated by the arrow in the figure, the relationship between the hall sensor output signals  $S_u$ ,  $S_v$ ,  $S_w$  and the inverse power of each motor phase  $V_u$ ,  $V_v$ ,  $V_w$  becomes as shown in the figure below.

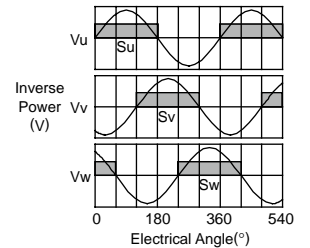

Moving Coil Model SGLFW-	L1	L2	L3	Approx. Mass kg
35□120A□	127	72	108	1.3
35□230A□	235	180	216	2.3

**External Dimensions** Units: mm

- Moving Coil: SGLFW-35□□□□A□D (With a connector by Interconnectron GmbH)

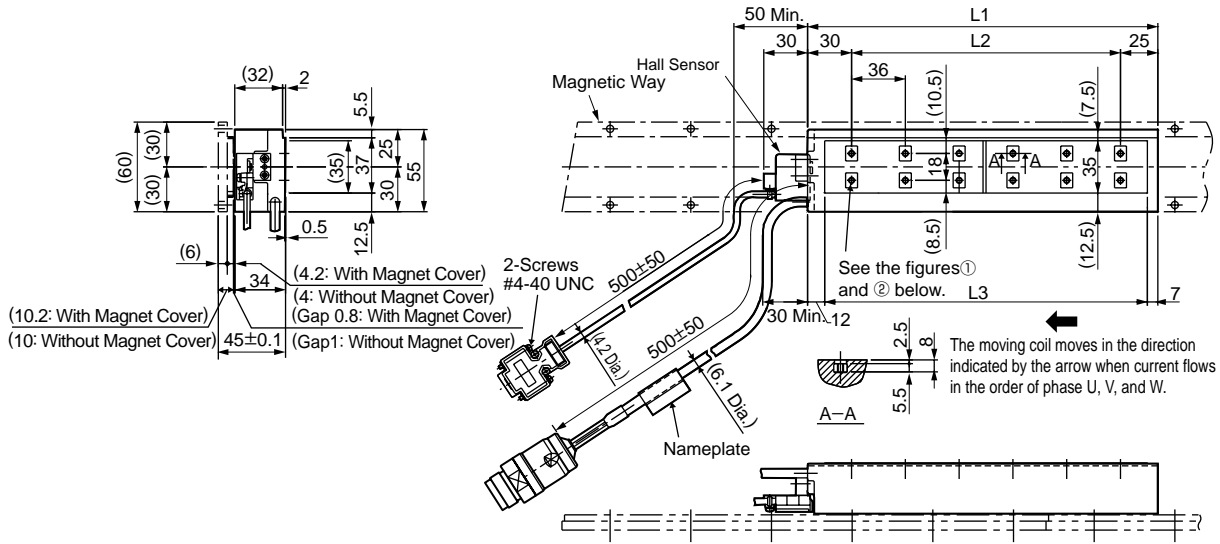

① SGLFW-35□120A□D

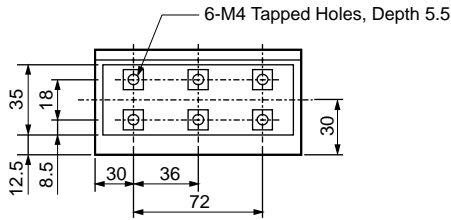

② SGLFW-35□230A□D

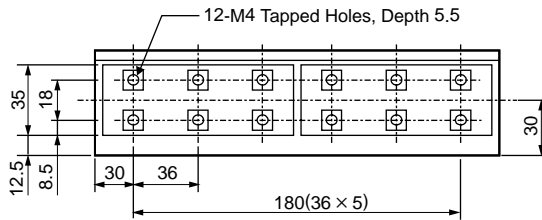

Hall Sensor Connector Specifications

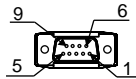

Pin Connector :  
17JE-23090-02 (D8C)  
by DDK Ltd.

The Mating Connector

Socket Connector:  
17JE-13090-02 (D8C)  
Stud: 17L-002C or  
17L-002C1

Pin No.	Signal
1	+5V (Power supply)
2	Phase U
3	Phase V
4	Phase W
5	0V (Power supply)
6	Not used
7	Not used
8	Not used
9	Not used

Linear Servomotor Connector Specifications



Extension: ARRA06AMRPN182  
Pin : 021.279.1020  
by Interconnectron GmbH

The Mating Connector

Plug : APRA06BFRDN170  
Socket: 020.105.1020

Pin No.	Name
1	Phase U
2	Phase V
4	Phase W
5	Not used
6	Not used
⊕	Ground

Hall Sensor Output Signals

When the moving coil moves in the direction indicated by the arrow in the figure, the relationship between the hall sensor output signals  $S_u$ ,  $S_v$ ,  $S_w$  and the inverse power of each motor phase  $V_u$ ,  $V_v$ ,  $V_w$  becomes as shown in the figure below.

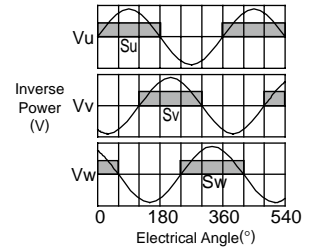

Moving Coil Model SGLFW-	L1	L2	L3	N	Approx. Mass kg
35□120A□D	127	72	108	6	1.3
35□230A□D	235	180	216	12	2.3

## External Dimensions Units: mm

- Magnetic Way: SGLFM-35□□□A

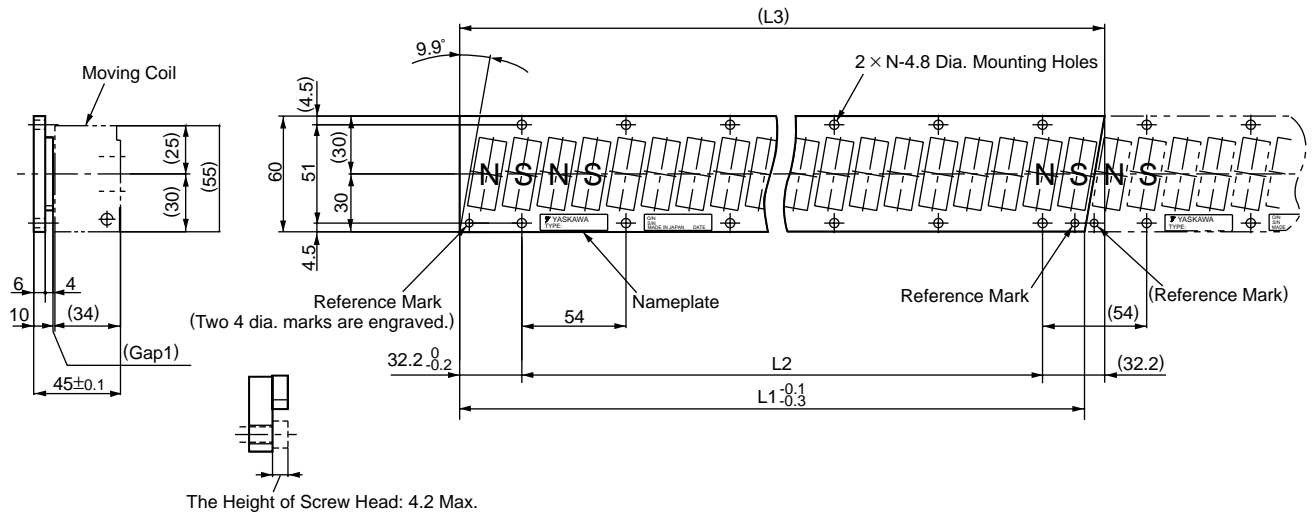

### Assembly Dimensions

- Notes: 1 Multiple SGLFM-35□□□A magnetic ways can be connected. Connect magnetic ways so that the reference marks match one on the other in the same direction as shown in the figure.  
 2 If you have a pacemaker or any other electronic medical device, do not go near the magnetic way of the linear servomotor.

Magnetic Way Model SGLFM-	$L1_{-0.3}^{+0.1}$	L2	(L3)	N	Approx. Mass kg
35324A	324	270 (54×5)	(334.4)	6	1.2
35540A	540	486 (54×9)	(550.4)	10	2
35756A	756	702 (54×13)	(766.4)	14	2.9

**External Dimensions** Units: mm

(3) SGLFW-50

- Moving Coil: SGLFW-50□□□□B□ (With a connector by Tyco Electronics AMP K.K.)

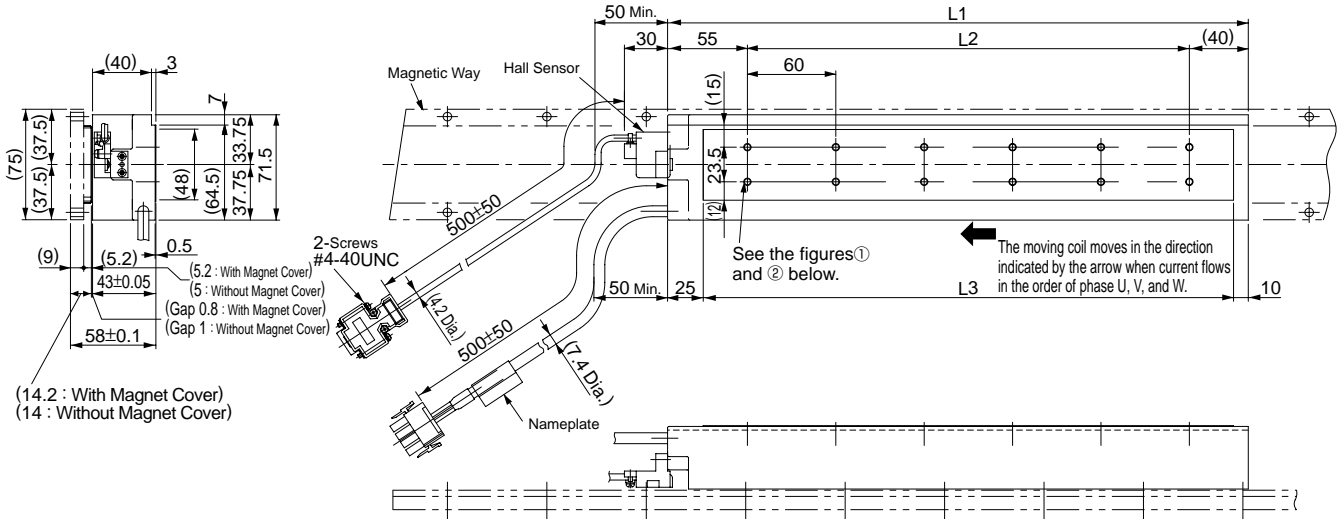

① SGLFW-50□200B□

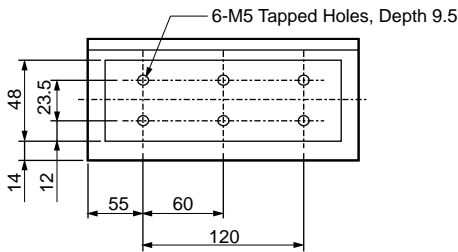

② SGLFW-50□380B□

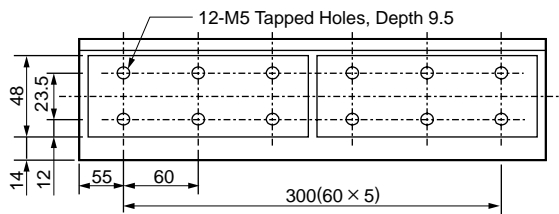

Hall Sensor Connector Specifications

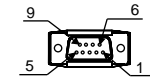

Pin Connector : 17JE-23090-02 (D8C) by DDK Ltd.

The Mating Connector

Socket Connector: 17JE-13090-02 (D8C) Stud: 17L-002C or 17L-002C1

Pin No.	Signal
1	+5V (Power supply)
2	Phase U
3	Phase V
4	Phase W
5	0V (Power supply)
6	Not used
7	Not used
8	Not used
9	Not used

Linear Servomotor Connector Specifications

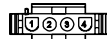

Plug: 350779-1  
Pin : 350218-3 or 350547-3 (No.1 to 3) 350654-1 350669-1 (No.4) by Tyco Electronics AMP K.K.

The Mating Connector

Cap : 350780-1  
Socket: 350536-3 or 350550-3

Pin No.	Signal	Wire Color
1	Phase U	Red
2	Phase V	White
3	Phase W	Black
4	FG	Green

Hall Sensor Output Signals

When the moving coil moves in the direction indicated by the arrow in the figure, the relationship between the hall sensor output signals  $S_u$ ,  $S_v$ ,  $S_w$  and the inverse power of each motor phase  $V_u$ ,  $V_v$ ,  $V_w$  becomes as shown in the figure below.

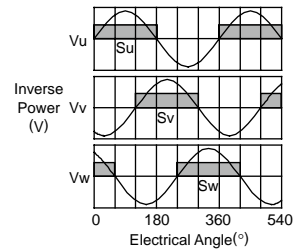

Moving Coil Model SGLFW-	L1	L2	L3	Approx. Mass kg
50□200B□	215	120	180	3.5
50□380B□	395	300	360	6.9

# External Dimensions Units: mm

- Moving Coil: SGLFW-50□□□□B□D (With a connector by Interconnectron GmbH)

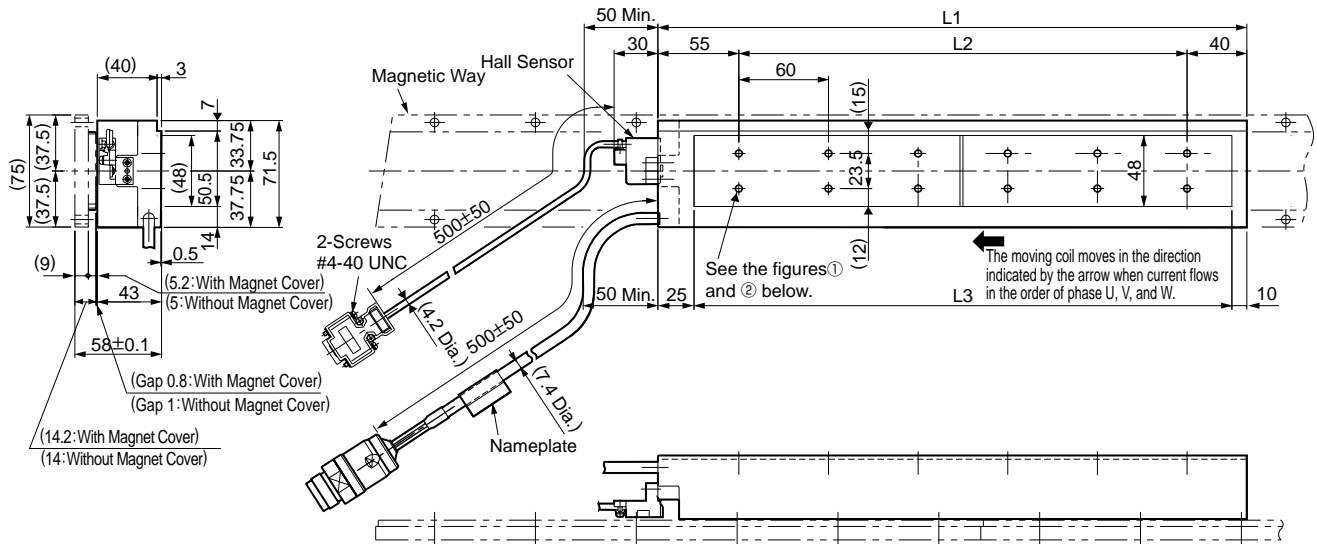

① SGLFW-50□200B□D

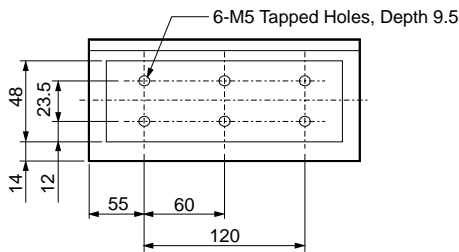

② SGLFW-50□380B□D

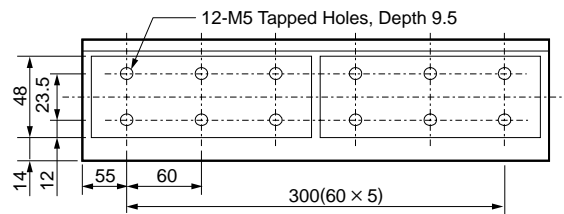

## Hall Sensor Connector Specifications

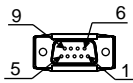

Pin Connector :  
17JE-23090-02 (D8C)  
by DDK Ltd.

## The Mating Connector

Socket Connector:  
17JE-13090-02 (D8C)  
Stud: 17L-002C or  
17L-002C1

Pin No.	Signal
1	+5V (Power supply)
2	Phase U
3	Phase V
4	Phase W
5	0V (Power supply)
6	Not used
7	Not used
8	Not used
9	Not used

## Linear Servomotor Connector Specifications



Extension: ARRA06AMRPN182  
Pin : 021.279.1020  
by Interconnectron GmbH

## The Mating Connector

Plug : APRA06BFRDN170  
Socket: 020.105.1020

Pin No.	Name
1	Phase U
2	Phase V
4	Phase W
5	Not used
6	Not used
⊕	Ground

## Hall Sensor Output Signals

When the moving coil moves in the direction indicated by the arrow in the figure, the relationship between the hall sensor output signals  $S_u$ ,  $S_v$ ,  $S_w$  and the inverse power of each motor phase  $V_u$ ,  $V_v$ ,  $V_w$  becomes as shown in the figure below.

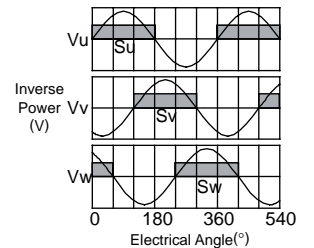

Moving Coil Model SGLFW-	L1	L2	L3	N	Approx. Mass kg
50□200B□D	215	120	180	6	3.5
50□380B□D	395	300	360	12	6.9

**External Dimensions** Units: mm

- Magnetic Way: SGLFM-50□□□A

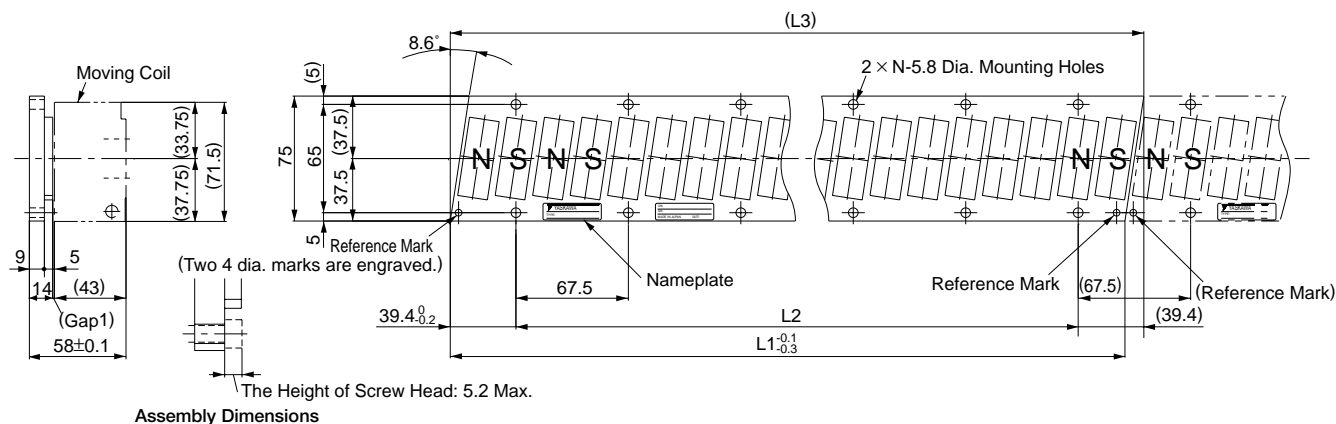

Assembly Dimensions

- Notes: 1 Multiple SGLFM-50□□□A magnetic ways can be connected. Connect magnetic ways so that the reference marks match one on the other in the same direction as shown in the figure.  
 2 If you have a pacemaker or any other electronic medical device, do not go near the magnetic way of the linear servomotor.

Magnetic Way Model SGLFM-	$L1_{-0.3}^{+0.1}$	$L2$	( $L3$ )	N	Approx. Mass kg
50405A	405	337.5 (67.5 × 5)	(416.3)	6	2.8
50675A	675	607.5 (67.5 × 9)	(686.3)	10	4.6
50945A	945	877.5 (67.5 × 13)	(956.3)	14	6.5

# External Dimensions Units: mm

## (4) SGLFW-1Z

- Moving Coil: SGLFW-1Z□□□□B□ (With a connector by Tyco Electronics AMP K.K.)

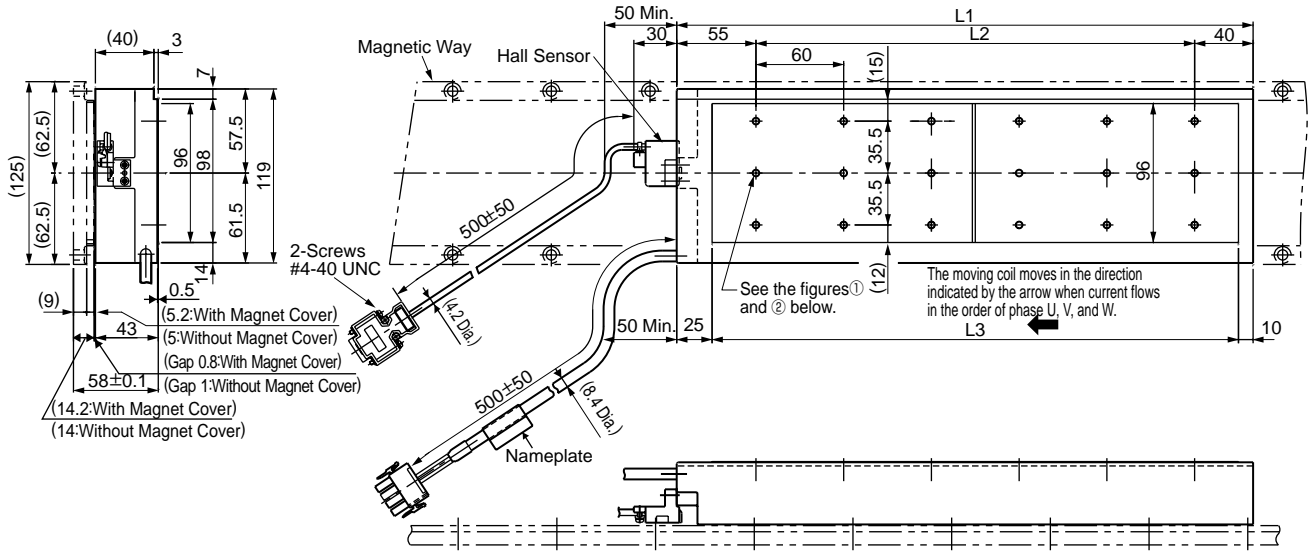

① SGLFW-1Z□200B□

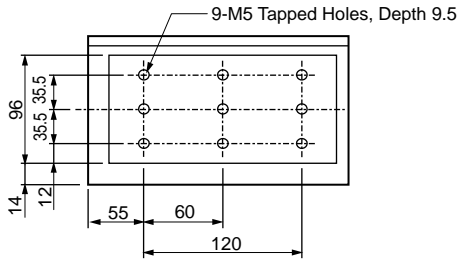

② SGLFW-1Z□380B□

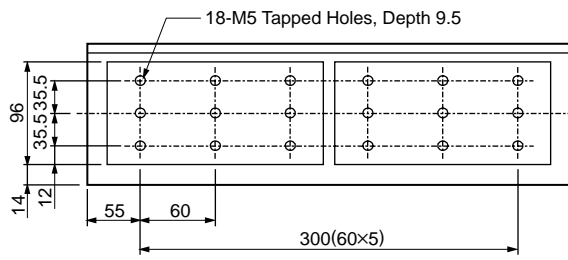

### Hall Sensor Connector Specifications

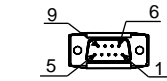

Pin Connector :  
17JE-23090-02 (D8C)  
by DDK Ltd.

### The Mating Connector

Socket Connector:  
17JE-13090-02 (D8C)  
Stud: 17L-002C or  
17L-002C1

Pin No.	Signal
1	+5V (Power supply)
2	Phase U
3	Phase V
4	Phase W
5	0V (Power supply)
6	Not used
7	Not used
8	Not used
9	Not used

### Linear Servomotor Connector Specifications

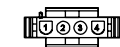

Plug: 350779-1  
Pin : 350218-3 or  
350547-3 (No.1 to 3)  
350654-1  
350669-1 (No.4)  
by Tyco Electronics AMP K.K.

### The Mating Connector

Cap : 350780-1  
Socket: 350536-3 or  
350550-3

### Hall Sensor Output Signals

When the moving coil moves in the direction indicated by the arrow in the figure, the relationship between the hall sensor output signals  $S_u$ ,  $S_v$ ,  $S_w$  and the inverse power of each motor phase  $V_u$ ,  $V_v$ ,  $V_w$  becomes as shown in the figure below.

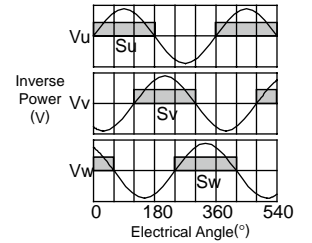

Moving Coil Model SGLFW-	L1	L2	L3	N	Approx. Mass kg
1Z□200B□	215	120	180	9	6.4
1Z□380B□	395	300	360	18	11.5

**External Dimensions** Units: mm

- Moving Coil: SGLFW-1Z□□□□B□D (With a connector by Interconnectron GmbH)

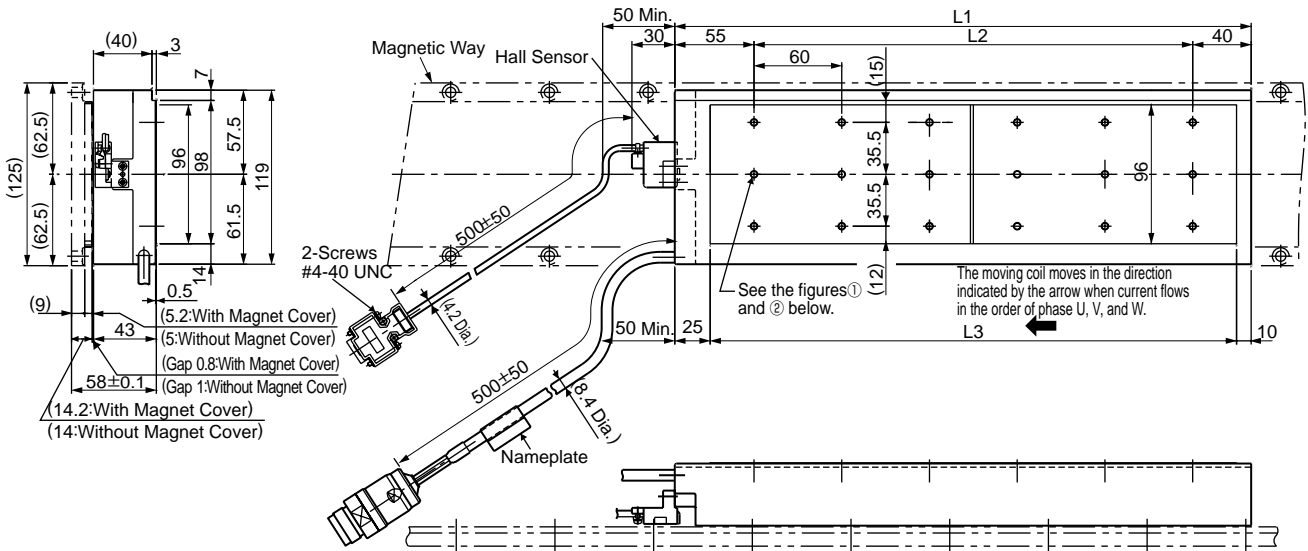

① SGLFW-1Z□200B□D

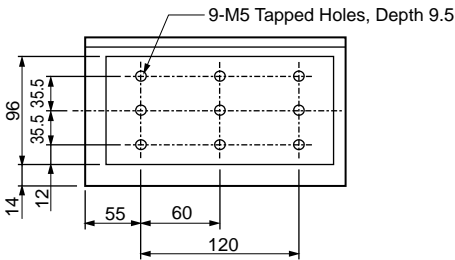

② SGLFW-1ZD380B□D

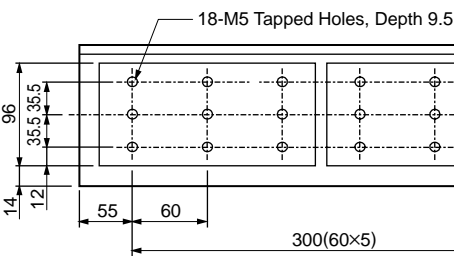

Hall Sensor Connector Specifications

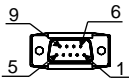

Pin Connector : 17JE-23090-02 (D8C) by DDK Ltd.

The Mating Connector

Socket Connector: 17JE-13090-02 (D8C)  
Stud: 17L-002C or 17L-002C1

Pin No.	Signal
1	+5V (Power supply)
2	Phase U
3	Phase V
4	Phase W
5	0V (Power supply)
6	Not used
7	Not used
8	Not used
9	Not used

Linear Servomotor Connector Specifications



Extension: ARRA06AMRPN182  
Pin : 021.279.1020 by Interconnectron GmbH

The Mating Connector

Plug : APRA06BFRDN170  
Socket : 020.105.1020

Pin No.	Name
1	Phase U
2	Phase V
4	Phase W
5	Not used
6	Not used
⊕	Ground

Hall Sensor Output Signals

When the moving coil moves in the direction indicated by the arrow in the figure, the relationship between the hall sensor output signals  $S_u$ ,  $S_v$ ,  $S_w$  and the inverse power of each motor phase  $V_u$ ,  $V_v$ ,  $V_w$  becomes as shown in the figure below.

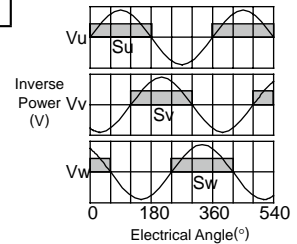

Moving Coil Model SGLFW-	L1	L2	L3	N	Approx. Mass kg
1Z□200B□D	215	120	180	9	6.4
1ZD380B□D	395	300	360	18	11.5



## External Dimensions Units: mm

● Magnetic Way: SGLFM-1Z□□□A

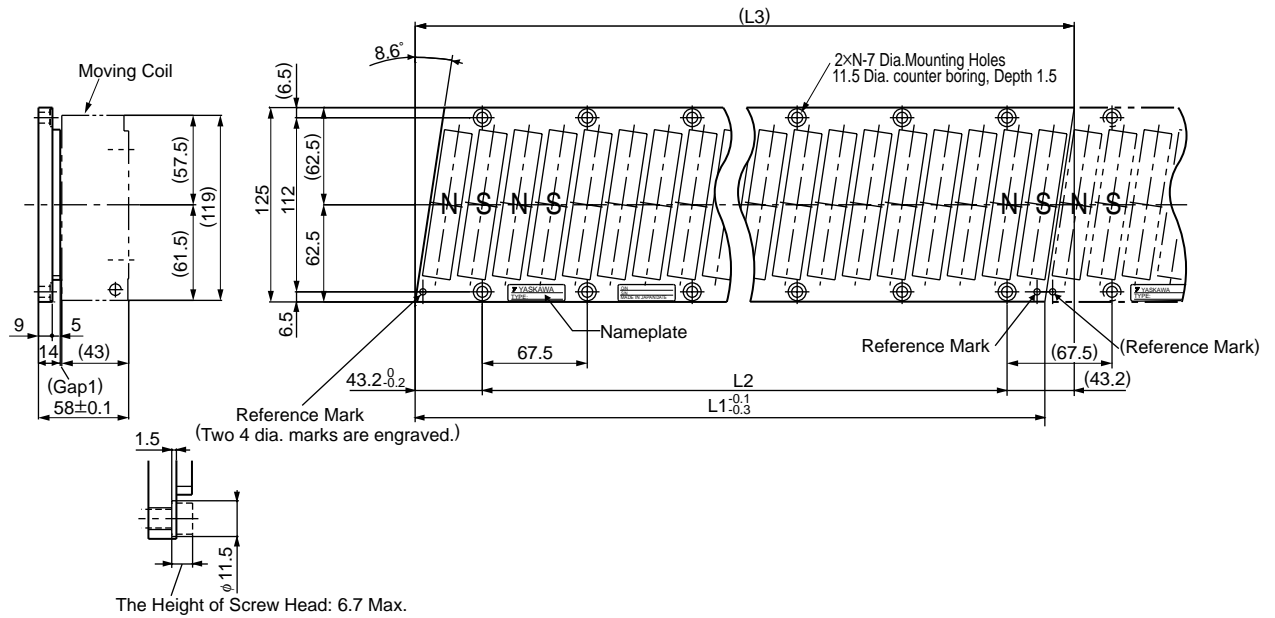

### Assembly Dimensions

Notes: 1 Multiple SGLFM-1Z□□□A magnetic ways can be connected. Connect magnetic ways so that the reference marks match one on the other in the same direction as shown in the figure.

2 If you have a pacemaker or any other electronic medical device, do not go near the magnetic way of the linear servomotor.

Magnetic Way Model SGLFM-	$L1$ $^{0.1}_{-0.3}$	$L2$	$L3$	N	Approx. Mass kg
1Z405A	405	337.5 (67.5 × 5)	(423.9)	6	5
1Z675A	675	607.5 (67.5 × 9)	(693.9)	10	8.3
1Z945A	945	877.5 (67.5 × 13)	(963.9)	14	12

Selecting Cables

● Cables Connections

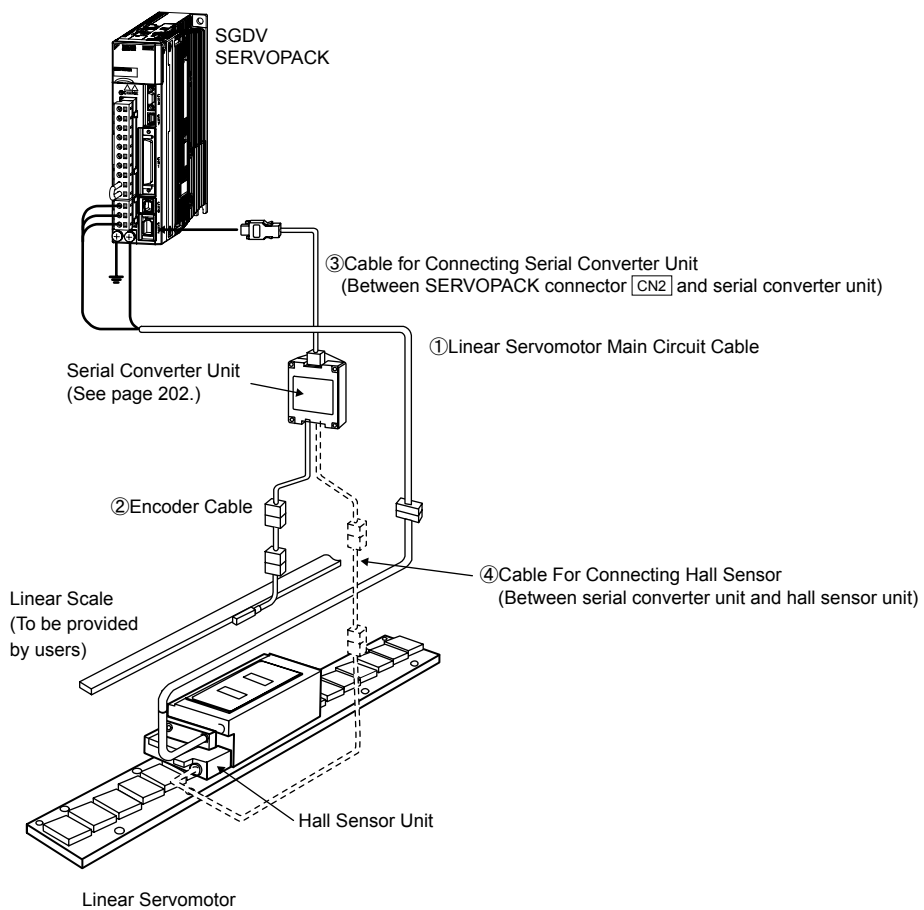

# Selecting Cables

## ● Cables

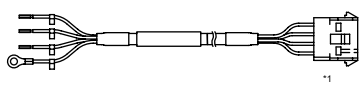
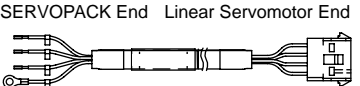
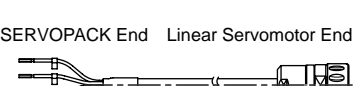
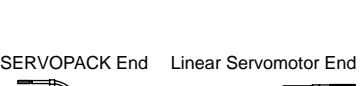
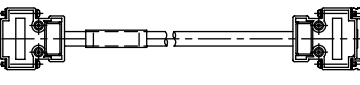
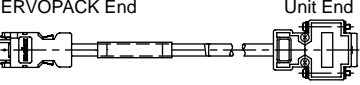
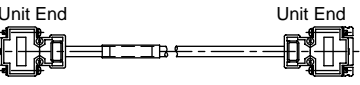
Name	Applicable Linear Servomotor Model	Length	Order No.	Specifications	Details
① Linear Servomotor Main Circuit Cables	SGLFW-20, -35	1 m	JZSP-CLN11-01-E	SERVOPACK End Linear Servomotor End 	(1)
		3 m	JZSP-CLN11-03-E		
		5 m	JZSP-CLN11-05-E		
		10 m	JZSP-CLN11-10-E		
		15 m	JZSP-CLN11-15-E		
		20 m	JZSP-CLN11-20-E		
	SGLFW-50, -1Z	1 m	JZSP-CLN21-01-E	SERVOPACK End Linear Servomotor End 	(2)
		3 m	JZSP-CLN21-03-E		
		5 m	JZSP-CLN21-05-E		
		10 m	JZSP-CLN21-10-E		
		15 m	JZSP-CLN21-15-E		
		20 m	JZSP-CLN21-20-E		
	SGLFW- □□A□□□□□D	1 m	JZSP-CLN14-01-E	SERVOPACK End Linear Servomotor End 	(3)
		3 m	JZSP-CLN14-03-E		
		5 m	JZSP-CLN14-05-E		
		10 m	JZSP-CLN14-10-E		
		15 m	JZSP-CLN14-15-E		
		20 m	JZSP-CLN14-20-E		
	SGLFW- □□D□□□□□D	1 m	JZSP-CLN15-01-E	SERVOPACK End Linear Servomotor End 	(4)
		3 m	JZSP-CLN15-03-E		
5 m		JZSP-CLN15-05-E			
10 m		JZSP-CLN15-10-E			
15 m		JZSP-CLN15-15-E			
20 m		JZSP-CLN15-20-E			
② Cables for Connecting Linear Scales <sup>3</sup>	All models	1 m	JZSP-CLL00-01-E	Serial Converter Unit End Linear Scale End 	(5)
		3 m	JZSP-CLL00-03-E		
		5 m	JZSP-CLL00-05-E		
		10 m	JZSP-CLL00-10-E		
		15 m	JZSP-CLL00-15-E		
③ Cables for Connecting Serial Converter Units	All models	1 m	JZSP-CLP70-01-E	SERVOPACK End Serial Converter Unit End 	(6)
		3 m	JZSP-CLP70-03-E		
		5 m	JZSP-CLP70-05-E		
		10 m	JZSP-CLP70-10-E		
		15 m	JZSP-CLP70-15-E		
		20 m	JZSP-CLP70-20-E		
④ Cables for Connecting Hall Sensors	All models	1 m	JZSP-CLL10-01-E	Serial Converter Unit End Hall Sensor Unit End 	(7)
		3 m	JZSP-CLL10-03-E		
		5 m	JZSP-CLL10-05-E		
		10 m	JZSP-CLL10-10-E		
		15 m	JZSP-CLL10-15-E		

\*1: Connector by Tyco Electronics AMP K.K.

\*2: Connector by Interconnectron GmbH

\*3: When using the serial converter unit, JZDP-G00□-□□□-E, the maximum cable length is 3 m.

NOTE: Shaded items are non-stock.

Selecting Cables

(1) Linear Servomotor Main Circuit Cables: JZSP-CLN11-□□-E

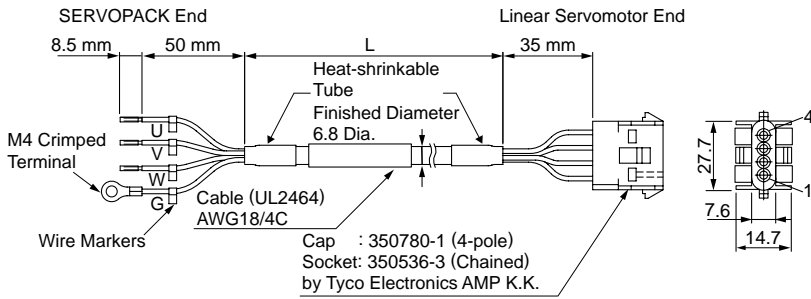

· Wiring Specifications

SERVOPACK-end Leads		Linear Servomotor-end Connector	
Wire Color	Signal	Signal	Pin No.
Red	Phase U	Phase U	1
White	Phase V	Phase V	2
Blue	Phase W	Phase W	3
Green/yellow	FG	FG	4

(2) Linear Servomotor Main Circuit Cables: JZSP-CLN21-□□-E

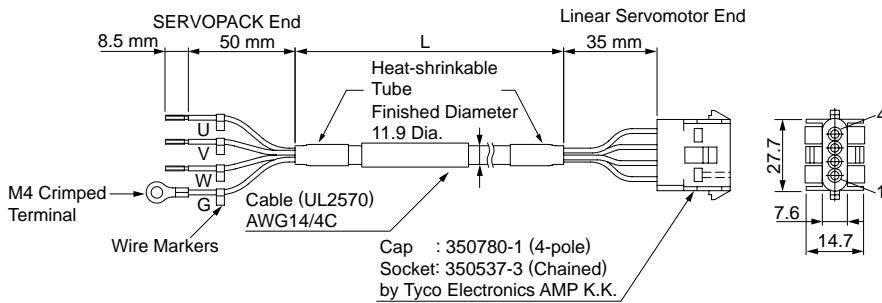

· Wiring Specifications

SERVOPACK-end Leads		Linear Servomotor-end Connector	
Wire Color	Signal	Signal	Pin No.
Red	Phase U	Phase U	1
White	Phase V	Phase V	2
Blue	Phase W	Phase W	3
Green/yellow	FG	FG	4

(3) Linear Servomotor Main Circuit Cables: JZSP-CLN14-□□-E

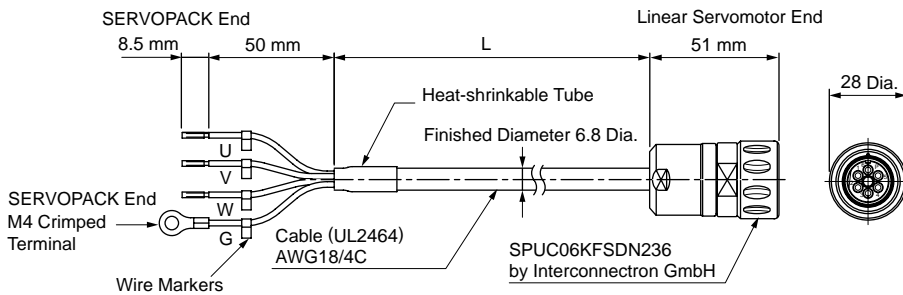

· Wiring Specifications

SERVOPACK-end Leads		Linear Servomotor-end Connector	
Wire Color	Signal	Signal	Pin No.
Black (White 1)	Phase U	Phase U	1
Black (White 2)	Phase V	Phase V	2
Black (White 3)	Phase W	Phase W	3
Green/yellow	FG	—	4
		—	5
		FG	6

# Selecting Cables

## (4) Linear Servomotor Main Circuit Cables: JZSP-CLN15-□□-E

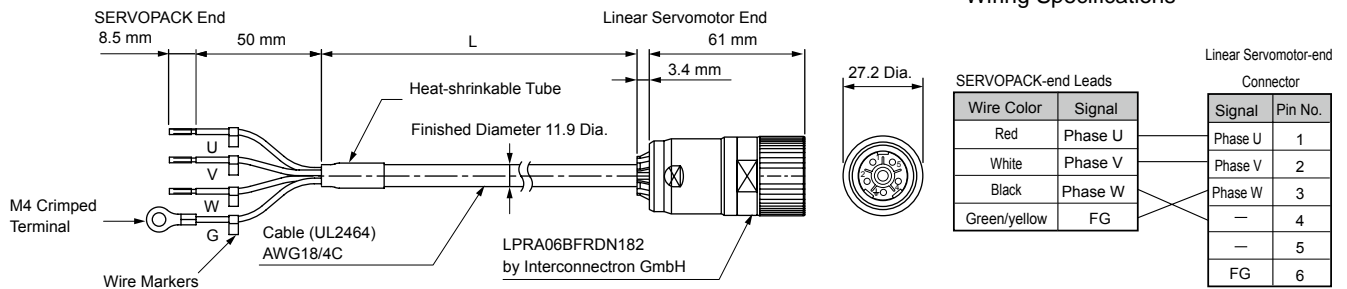

## (5) Cables for Connecting Linear Scales: JZSP-CLL00-□□-E

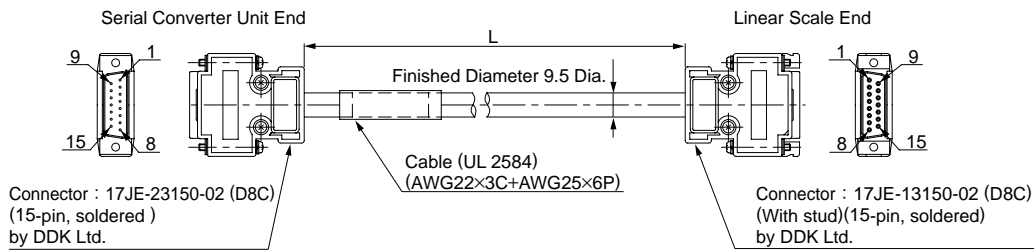

### · Wiring Specifications

Serial Converter Unit End		Linear Scale End	
Pin No.	Signal	Pin No.	Signal
1	/Cos(V1-)	1	/Cos(V1-)
2	/Sin(V2-)	2	/Sin(V2-)
3	Ref(V0+)	3	Ref(V0+)
4	+5V	4	+5V
5	5Vs	5	5Vs
6	BID	6	BID
7	Vx	7	Vx
8	Vq	8	Vq
9	Cos(V1+)	9	Cos(V1+)
10	Sin(V2+)	10	Sin(V2+)
11	/Ref(V0+)	11	/Ref(V0-)
12	0V	12	0V
13	0Vs	13	0Vs
14	DIR	14	DIR
15	Inner	15	Inner
Case	Shield	Case	Shield

Selecting Cables

(6) Cables for Connecting Serial Converter Units: JZSP-CLP70-□□-E

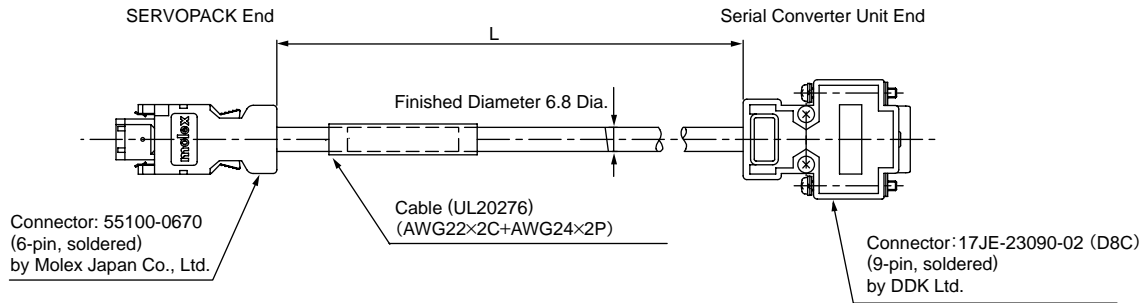

· Wiring Specifications

SERVOPACK End			Serial Converter Unit End		
Pin No.	Signal	Wire Color	Pin No.	Signal	Wire Color
1	PG5V	Red	1	+5V	Red
2	PG0V	Black	5	0V	Black
3	-	-	3	-	-
4	-	-	4	-	-
5	PS	Light blue	2	Phase S output	Light blue
6	/PS	Light blue/white	6	Phase /S output	Light blue/white
Shell	Shield	-	Case	Shield	-
			7	-	-
			8	-	-
			9	-	-

(7) Cables for Connecting Hall Sensors: JZSP-CLL10-□□-E

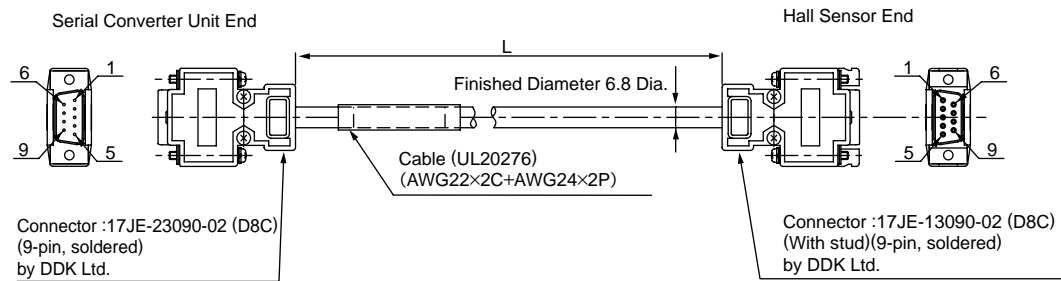

· Wiring Specifications

Serial Converter Unit End		Hall Sensor End	
Pin No.	Signal	Pin No.	Signal
1	+5V	1	+5V
2	Phase U input	2	Phase U input
3	Phase V input	3	Phase V input
4	Phase W input	4	Phase W input
5	0V	5	0V
6	-	6	-
7	-	7	-
8	-	8	-
9	-	9	-
Case	Shield	Case	Shield

# Linear Servomotors

# SGLTW

(With T-type iron core)

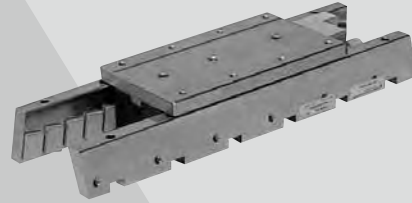

## Model Designations

### ● Moving Coil (All Models are Non-Stock)

**SGL T W - 20 A 170 A P □**

Linear  $\Sigma$  Series

Servomotor Type

Code	Specifications
T	T-type iron core

W: Moving Coil

Magnet Height

Voltage

A: 200 VAC  
D: 400 VAC

Length of Moving Coil

Design Revision Order

A, B, ...  
H: High-efficiency Type

Connector for Main Circuit Cable

Code	Specification	Applicable Model
Blank	Connector by Tyco Electronics AMP K.K.	SGLTW
		-20A□□□□□□
		-35A□□□□□□
D	MS connector	SGLTW
		-40□□□□B□
		-80□□□□B□
D	Connector by Interconnectron GmbH	SGLTW
		-35D□□□□H□
	-50D□□□□H□	

Hall Sensor

Code	Specifications
P	With hall sensor
Blank	Without hall sensor

Note: Shaded items are non-stock

### ● Magnetic Way (All Models are Non-Stock)

**SGL T M - 20 324 A □**

Linear  $\Sigma$  Series

Linear Servomotor

Servomotor Type

Code	Specifications
T	T-type iron core

M: Magnetic Way

Magnet Height

Length of Magnetic Way

Options

Code	Specifications	Applicable Model
Blank	Standard	All models
C	With magnet cover	Models with core
Y	With base and magnet cover	SGLTM-20, -35, -40, -80(Note)

Note: Not available for these models: the SGLTM-35□□□□H and the SGLTM-50□□□□H.

Design Revision Order

A, B, ...  
H: High-efficiency Type

- Direct-feed mechanism for high-speed and high-precision positioning.
- Yaskawa's unique construction principles of the TW linear motors negate the effects of the magnetic attraction force between the relative motor members.
- Lack of magnetic attraction helps to extend the life of the linear motion guides and to minimize operation noise.
- Very little cogging.

- Feeders and loaders
- Mounters
- Machine tools

### ● Precautions on Moving Coil with Hall Sensor

When using a moving coil with a hall sensor, the magnetic way must completely cover the bottom of the hall sensor. Refer to the example showing the correct installation.

When determining the length of the moving coil's stroke or the length of the magnetic way, consider the total length of the moving coil and the hall sensor unit. Refer to the following table.

< Correct >

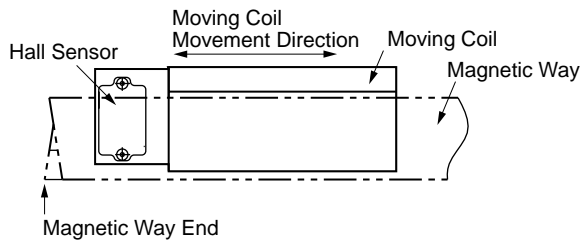

< Incorrect >

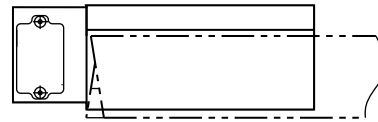

The total length of moving coil with hall sensor

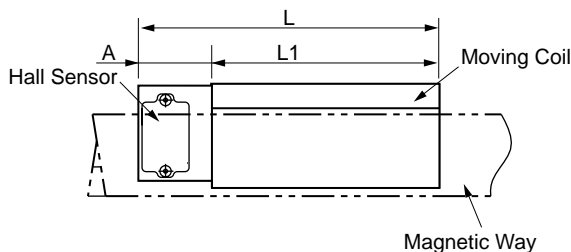

Moving Coil Model	Length of Moving Coil L1 (mm)	Length of Hall Sensor Unit A (mm)	Total Length L (mm)	
20A170AP□	170	34	204	
20A320AP□	315		349	
20A460AP□	460		494	
35A170AP□	170	34	204	
35A320AP□	315		349	
35A460AP□	460		494	
35□170HP□	170	34	204	
35□320HP□	315		349	
50□170HP□	170		204	
50□320HP□	315	34	349	
40A400AP□	395		26	421
40A600AP□	585		36	621
80A400AP□	395	26	421	
80A600AP□	585		621	
40□400BP□	395		421	
40□600BP□	575	26	601	
80□400BP□	395		421	
80□600BP□	575		601	



## Ratings and Specifications

Time Rating: Continuous

Insulation Resistance: 500 VDC, 10 MΩ min.

Ambient Temperature: 0 to 40°C

Excitation: Permanent magnet

Withstand Voltage: 1500 VAC for one minute

Enclosure: Self-cooled

Ambient Humidity: 20% to 80% (no condensation)

Allowable Winding Temperature: 130°C (Thermal class B)

### 200-V Class

Linear Servomotor Model SGLTW- <span style="border: 1px solid black; padding: 0 5px;"> </span>		Standard Type								High-efficiency Type					
		20A			35A			40A		80A		35A		50A	
		170A	320A	460A	170A	320A	460A	400B	600B	400B	600B	170H	320H	170H	320H
Peak Speed	m/s	5	5	5	5	5	5	3.1	3.1	2.5	2.5	4.8	4.8	3.2	3.1
Rated Force*	N	130	250	380	220	440	670	670	1000	1300	2000	300	600	450	900
Rated Current*	A <sub>rms</sub>	2.3	4.4	6.7	3.5	7	10.7	7.3	10.9	11.1	17.1	5.1	10.1	4.9	9.8
Peak Force*	N	380	760	1140	660	1320	2000	2600	4000	5000	7500	600	1200	900	1800
Peak Current*	A <sub>rms</sub>	7.7	15.4	23.2	12.1	24.2	36.7	39.4	60.6	57.9	86.9	11.9	23.9	11.5	22.9
Moving Coil Mass	kg	2.5	4.6	6.7	3.7	6.8	10	15	23	24	35	4.9	8.8	6	11
Force Constant	N/A <sub>rms</sub>	61	61	61	67.5	67.5	67.5	99.1	99.1	126	126	64	64	98.5	98.5
BEMF Constant	V/(m/s)	20.3	20.3	20.3	22.5	22.5	22.5	33	33	42	42	21.3	21.3	32.8	32.8
Motor Constant	N/√w	18.7	26.5	32.3	26.7	37.5	46.4	61.4	75.2	94.7	116	37.4	52.9	50.3	71.1
Electrical Time Constant	ms	5.9	5.9	5.9	6.9	6.8	7	15.2	15.2	17	17	15.1	15.1	16.5	16.5
Mechanical Time Constant	ms	7.5	6.5	6.4	5.2	4.8	4.6	4	4	3	3	3.3	3.3	2.8	2.8
Thermal Resistance (With Heat Sink)	K/W	1.01	0.49	0.38	0.76	0.44	0.32	0.24	0.2	0.22	0.18	0.76	0.4	0.61	0.3
Thermal Resistance (Without Heat Sink)	K/W	1.82	1.11	0.74	1.26	0.95	0.61	0.57	0.4	0.47	0.33	1.26	0.83	0.97	0.8
Magnetic Attraction <sup>1</sup>	N	0	0	0	0	0	0	0	0	0	0	0	0	0	0
Magnetic Attraction(on one side) <sup>2</sup>	N	800	1590	2380	1400	2780	4170	3950	5890	7650	11400	1400	2780	2000	3980
Applicable SERVOPACK	SGDV-	3R8A	7R6A	120A	5R5A	120A	180A	180A	330A	330A	550A	5R5A	120A	5R5A	120A

\*1 : The unbalanced magnetic gap resulted from the moving coil installation condition causes a magnetic attraction on the moving coil.

\*2 : The value indicates the magnetic attraction generated on one side of the magnetic way.

Notes: 1 The items marked with an \* and Force and Speed Characteristics (on the next page) are the values at a motor winding temperature of 100°C during operation in combination with a SERVOPACK. The others are at 20°C.

2 The above specifications show the values under the cooling condition when a heat sink (aluminum board) listed in the following table is mounted on the moving coil.

Heat Sink Size	254 mm×254 mm×25 mm : SGLTW-20A170A,-35A170A
	400 mm×500 mm×40 mm : SGLTW-20A320A,-20A460A,-35A170H,-35A320A,-35A320H,-35A460A,-50A170H
	609 mm×762 mm×50 mm : SGLTW-40A400B,-40A600B,-50A320H,-80A400B,-80A600B

### 400-V Class

Linear Servomotor Model SGLTW- <span style="border: 1px solid black; padding: 0 5px;"> </span>		Standard Type				High-efficiency Type			
		40D		80D		35D		50D	
		400B	600B	400B	600B	170H	320H	170H	320H
Peak Speed	m/s	3.1	3.1	3.1	3.1	5	5	4	4
Rated Force*	N	670	1000	1300	2000	300	600	450	900
Rated Current*	A <sub>rms</sub>	3.7	5.5	7.2	11.1	3.2	6.5	3.2	6.3
Peak Force*	N	2600	4000	5000	7500	600	1200	900	1800
Peak Current*	A <sub>rms</sub>	20.7	30.6	37.6	56.4	7.7	15.5	7.4	14.8
Moving Coil Mass	kg	15	23	24	35	4.7	8.8	6	11
Force Constant	N/A <sub>rms</sub>	196.1	196.1	194.4	194.4	99.6	99.6	153.3	153.3
BEMF Constant	V/(m/s)	65.4	65.4	64.8	64.8	33.2	33.2	51.1	51.1
Motor Constant	N/√w	59.6	73	85.9	105.2	36.3	51.4	48.9	69.1
Electrical Time Constant	ms	14.3	14.4	15.6	15.6	14.3	14.4	15.6	15.6
Mechanical Time Constant	ms	4.3	4.2	3.2	3.2	3.5	3.3	2.5	2.5
Thermal Resistance (With Heat Sink)	K/W	0.24	0.2	0.22	0.18	0.76	0.4	0.61	0.3
Thermal Resistance (Without Heat Sink)	K/W	0.57	0.4	0.47	0.33	1.26	0.83	0.97	0.8
Magnetic Attraction <sup>1</sup>	N	0	0	0	0	0	0	0	0
Magnetic Attraction(on one side) <sup>2</sup>	N	3950	5890	7650	11400	1400	2780	2000	3980
Applicable SERVOPACK	SGDV-	120D	170D	170D	260D	3R5D	8R4D	3R5D	8R4D

\*1 : The unbalanced magnetic gap resulted from the moving coil installation condition causes a magnetic attraction on the moving coil.

\*2 : The value indicates the magnetic attraction generated on one side of the magnetic way.

Notes: 1 The items marked with an \* and Force and Speed Characteristics are the values at a motor winding temperature of 100°C during operation in combination with a SERVOPACK. The others are at 20°C.

2 The above specifications show the values under the cooling condition when a heat sink (aluminum board) listed in the following table is mounted on the moving coil.

Heat Sink Size	400 mm×500 mm×40 mm : SGLTW-35D170H,-35D320H,-50D170H
	609 mm×762 mm×50 mm : SGLTW-40D400B,-40D600B,-50D320H,-80D400B,-80D600B

**Ratings and Specifications**

● Force and Speed Characteristics **A** : Continuous Duty Zone **B** : Intermittent Duty Zone

200-V Class Standard Type

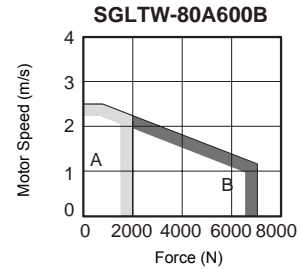
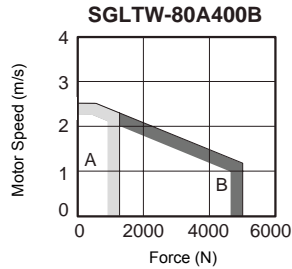
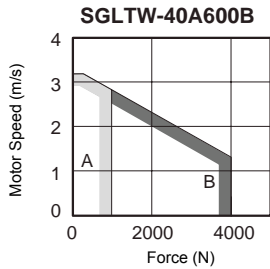
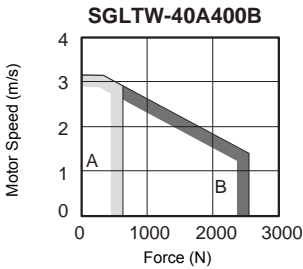
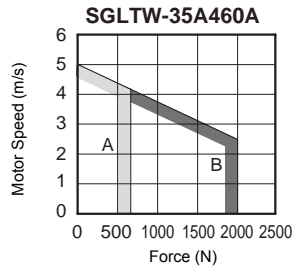
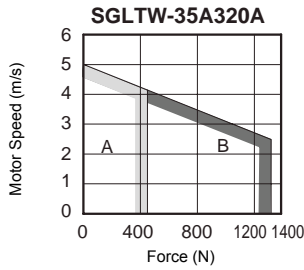
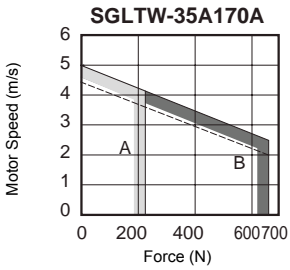
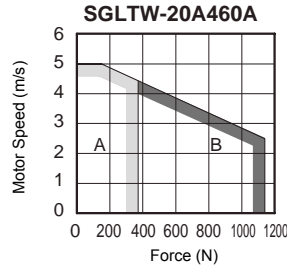
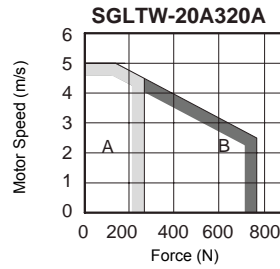
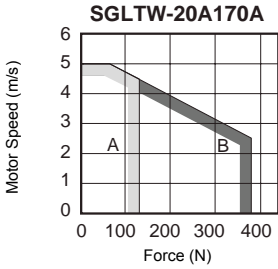

200-V Class High-efficiency Type

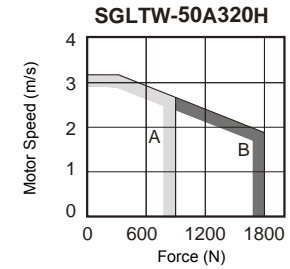
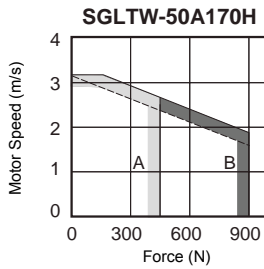
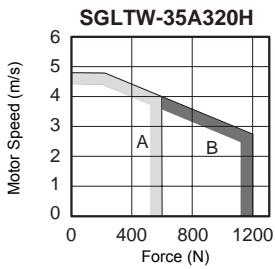
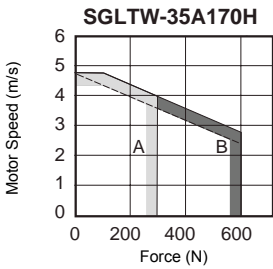

Note: When the effective force during intermittent duty is within the rated force, the servomotor can be used within the intermittent duty zone.

## Ratings and Specifications

### ● Force and Speed Characteristics (cont'd) A : Continuous Duty Zone B : Intermittent Duty Zone

#### 400-V Class Standard Type

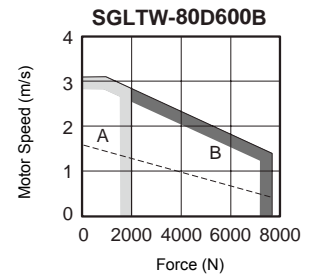
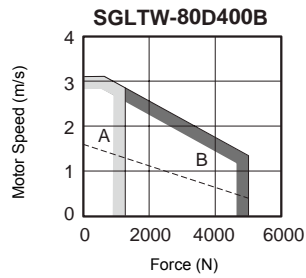
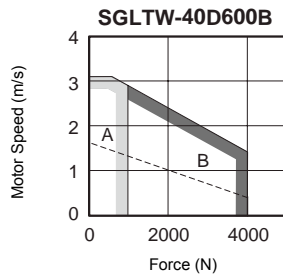
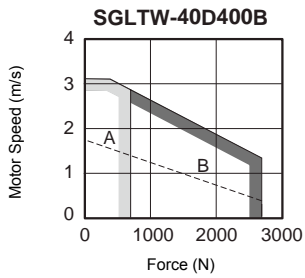

#### 400-V Class High-efficiency Type

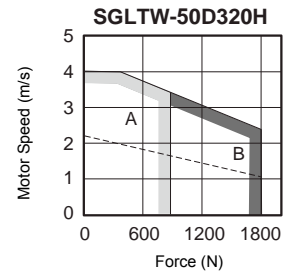
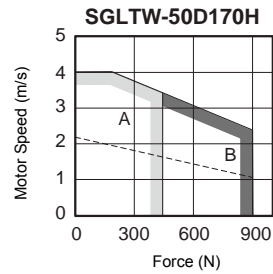
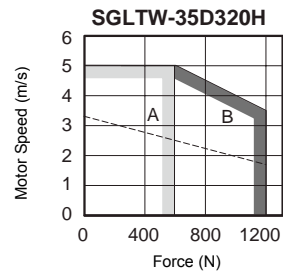
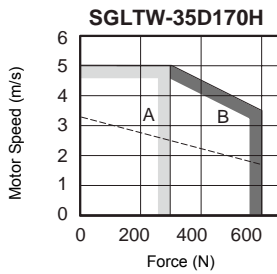

Notes: 1 When the effective force during intermittent duty is within the rated force, the servomotor can be used within the intermittent duty zone.

2 The dotted line indicates the characteristics when a 400-VAC linear servomotor is used with 200-V input power supply. In this case, a serial converter unit is required. Contact your Yaskawa representative for details.

### ● Mechanical Specifications

#### (1) Impact Resistance

- Impact acceleration: 196 m/s<sup>2</sup>
- Impact occurrences: twice

#### (2) Vibration Resistance

The linear servomotors will withstand the following vibration acceleration in three directions: Vertical, side to side, and front to back.

- Vibration acceleration: 49 m/s<sup>2</sup>

**External Dimensions** Units: mm

(1) Standard Type SGLTW-20

- Moving Coil: SGLTW-20A□□□A□ (With a connector by Tyco Electronics AMP K.K.)

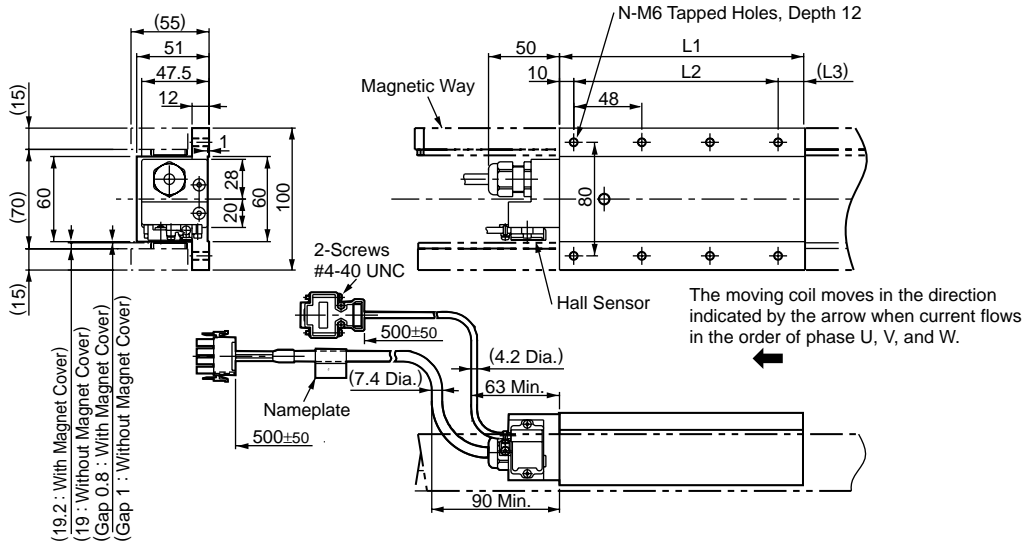

Hall Sensor Connector Specifications

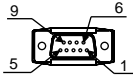

Pin Connector:  
17JE-23090-02 (D8C)  
by DDK Ltd.

The Mating Connector

Socket Connector:  
17JE-13090-02 (D8C)  
Stud: 17L-002C or  
17L-002C1

Pin No.	Signal
1	+5VDC
2	Phase U
3	Phase V
4	Phase W
5	0V
6	Not used
7	Not used
8	Not used
9	Not used

Linear Servomotor Connector Specifications

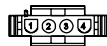

Plug: 350779-1  
Pin : 350218-3 or  
350547-3 (No.1 to 3)  
350654-1  
350669-1 (No.4)

by Tyco Electronics AMP K.K.

The Mating Connector

Cap : 350780-1  
Socket: 350536-3 or  
350550-3

Pin No.	Signal	Wire Color
1	Phase U	Red
2	Phase V	White
3	Phase W	Black
4	Ground	Green

Hall Sensor Output Signals

When the moving coil moves in the direction indicated by the arrow in the figure, the relationship between the hall sensor output signals  $S_u$ ,  $S_v$ ,  $S_w$  and the inverse power of each motor phase  $V_u$ ,  $V_v$ ,  $V_w$  becomes as shown in the figure below.

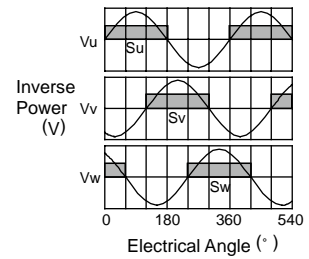

Moving Coil Model SGLTW-	L1	L2	(L3)	N	Approx. Mass kg
20A170A□	170	144 (48×3)	(16)	8	2.5
20A320A□	315	288 (48×6)	(17)	14	4.6
20A460A□	460	432 (48×9)	(18)	20	6.7

## External Dimensions Units: mm

- Magnetic Way : SGLTM-20□□□A□

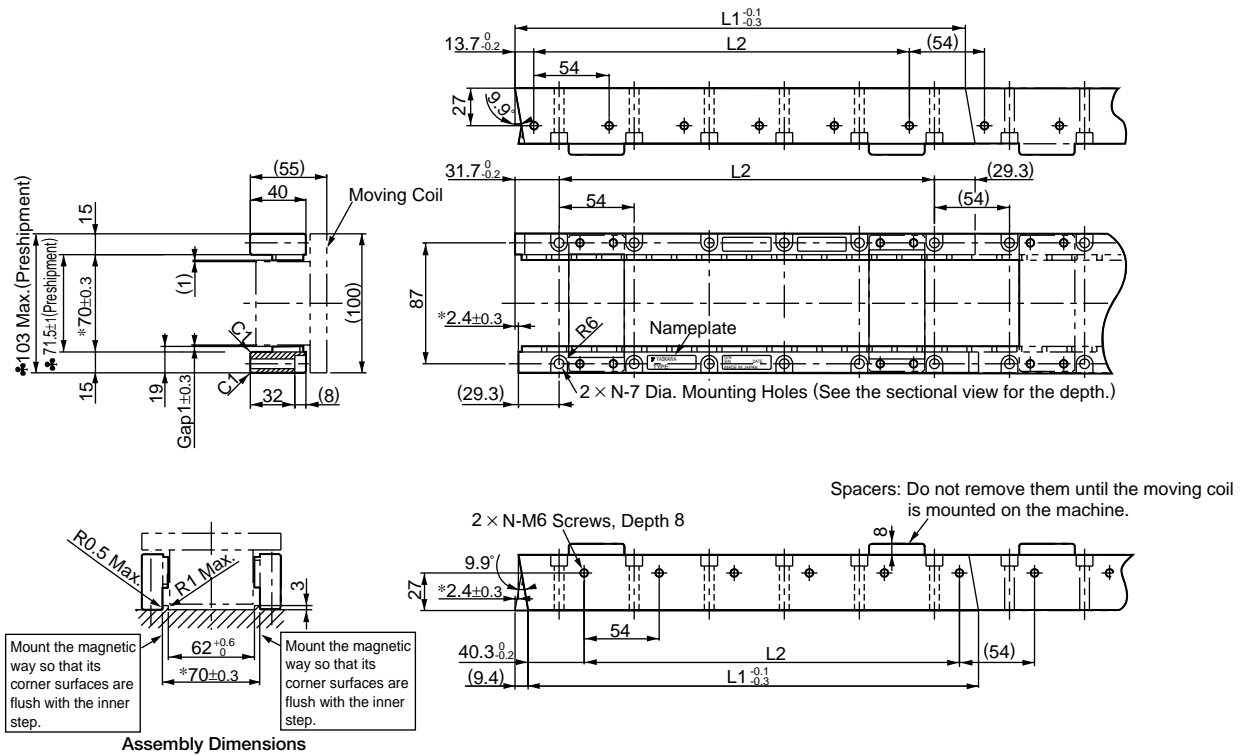

- Notes: 1 Two magnetic ways for both ends of moving coil make one set. Spacers are mounted on magnetic ways for safety during transportation. Do not remove the spacers until the moving coil is mounted on a machine.  
 2 If you have a pacemaker or any other electronic medical device, do not go near the magnetic way of the linear servomotor.  
 3 Two magnetic ways in a set can be connected to each other.  
 4 The dimensions marked with an \* are the dimensions between the magnetic ways. Be sure to follow exactly the dimensions specified in the figure above. Mount magnetic ways as shown in Assembly Dimensions. The values with a ♣ are the dimensions at preshipment.  
 5 Use socket headed screws of strength class 10.9 minimum for magnetic way mounting screws. Do not use stainless steel screws.

Magnetic Way Model SGLTM-	L1 <sup>0.1</sup> <sub>0.3</sub>	L2	N	Approx. Mass kg
20324A□	324	270 (54×5)	6	3.4
20540A□	540	486 (54×9)	10	5.7
20756A□	756	702 (54×13)	14	7.9

**External Dimensions** Units: mm

- Magnetic Way with Base: SGLTM-20□□□AY

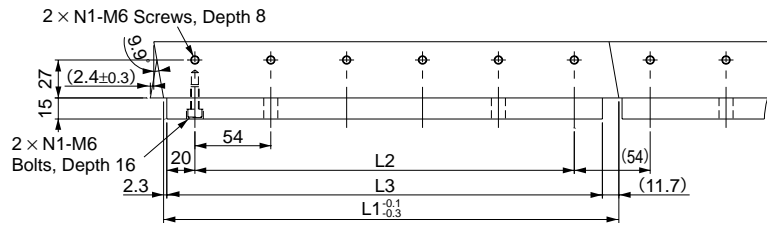
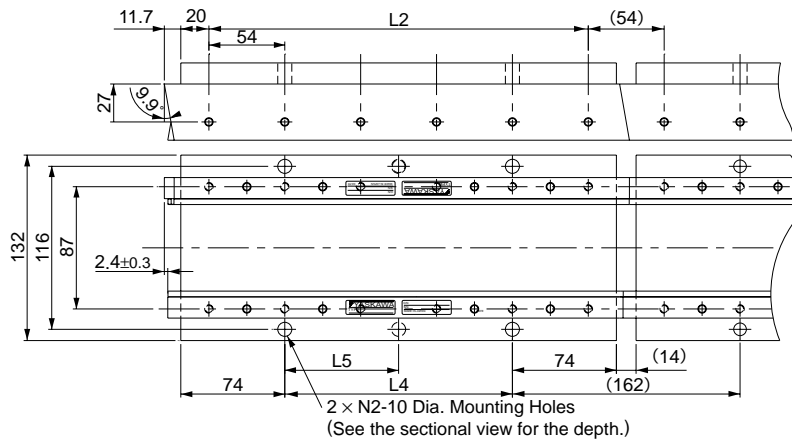
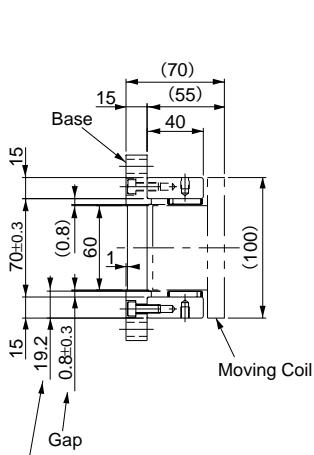

- Notes: 1 If you have a pacemaker or any other electronic medical device, do not go near the magnetic way of the linear servomotor.  
 2 Two magnetic ways in a set can be connected to each other.  
 3 The characteristics of the magnetic way with base are the same as of the magnetic way without base (SGLTM-20□□□A).

Magnetic Way Model SGLTM-	L1	L2	L3	L4	L5	N1	N2	Approx. Mass kg
20324AY	324	270	310	162	162	6	2	5.1
20540AY	540	486	526	378	189	10	3	8.5
20756AY	756	702	742	594	198	14	4	12

Linear Servomotors

## External Dimensions Units: mm

### (2) Standard Type SGLTW-35A

- Moving Coil: SGLTW-35A□□□A□ (With a connector by Tyco Electronics AMP K.K.)

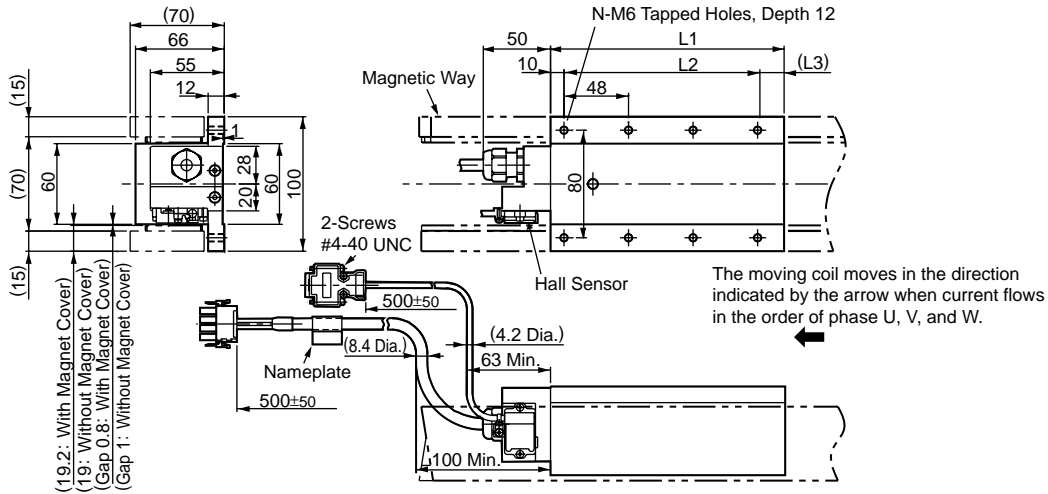

#### Hall Sensor Connector Specifications

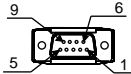

Pin Connector:  
17JE-23090-02 (D8C)  
by DDK Ltd.

The Mating Connector

Socket Connector:  
17JE-13090-02 (D8C)  
Stud: 17L-002C or  
17L-002C1

Pin No.	Signal
1	+5VDC
2	Phase U
3	Phase V
4	Phase W
5	0V
6	Not used
7	Not used
8	Not used
9	Not used

#### Linear Servomotor Connector Specifications

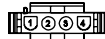

Plug: 350779-1  
Pin : 350218-3 or  
350547-3 (No.1 to 3)  
350654-1  
350669-1 (No.4)  
by Tyco Electronics AMP K.K.

The Mating Connector

Cap : 350780-1  
Socket: 350536-3 or  
350550-3

Pin No.	Signal	Wire Color
1	Phase U	Red
2	Phase V	White
3	Phase W	Black
4	Ground	Green

#### Hall Sensor Output Signals

When the moving coil moves in the direction indicated by the arrow in the figure, the relationship between the hall sensor output signals  $S_u$ ,  $S_v$ ,  $S_w$  and the inverse power of each motor phase  $V_u$ ,  $V_v$ ,  $V_w$  becomes as shown in the figure below.

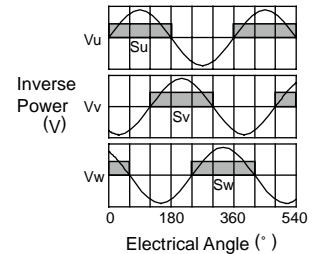

Moving Coil Model SGLTW-	L1	L2	(L3)	N	Approx. Mass kg
35A170A□	170	144 (48×3)	(16)	8	3.7
35A320A□	315	288 (48×6)	(17)	14	6.8
35A460A□	460	432 (48×9)	(18)	20	10

**External Dimensions** Units: mm

- Magnetic Way: SGLTM-35□□□A□

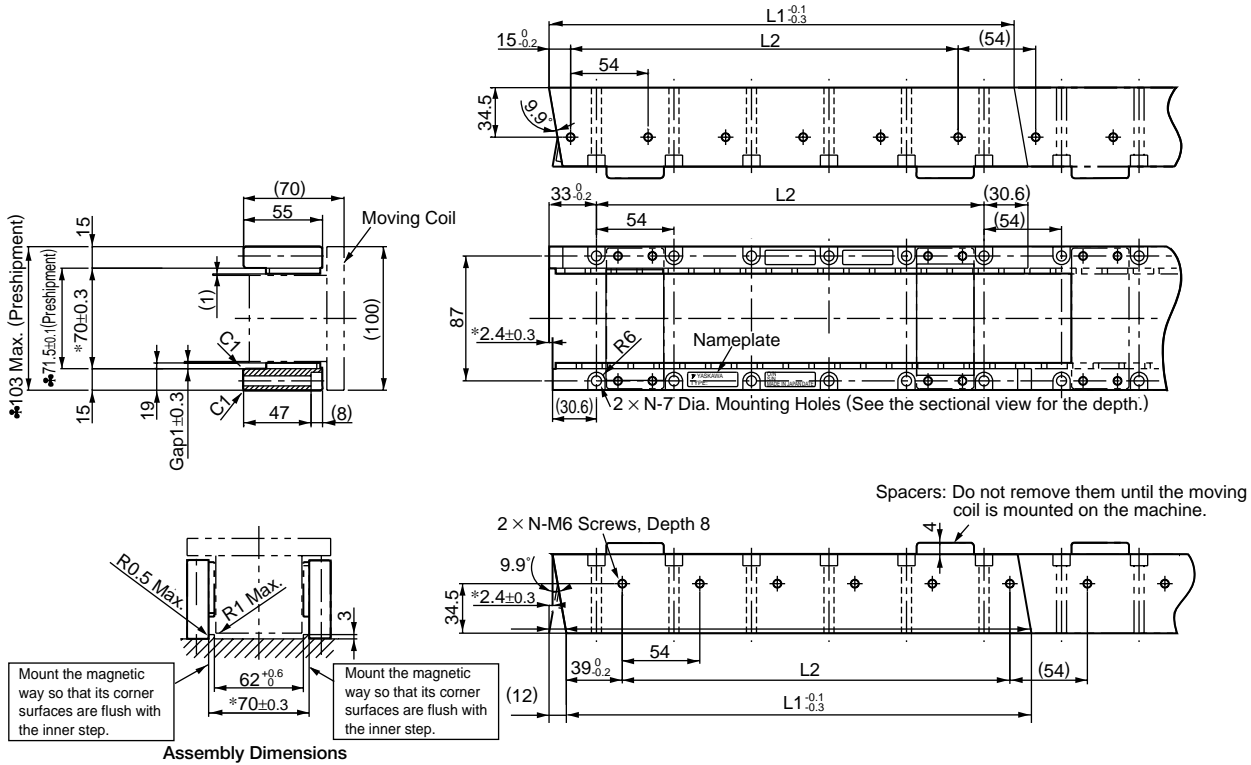

- Notes:
- 1 Two magnetic ways for both ends of moving coil make one set. Spacers are mounted on magnetic ways for safety during transportation. Do not remove the spacers until the moving coil is mounted on a machine.
  - 2 If you have a pacemaker or any other electronic medical device, do not go near the magnetic way of the linear servomotor.
  - 3 Two magnetic ways in a set can be connected to each other.
  - 4 The dimensions marked with an \* are the dimensions between the magnetic ways. Be sure to follow exactly the dimensions specified in the figure above. Mount magnetic ways as shown in Assembly Dimensions. The values with a ♣ are the dimensions at preshipment.
  - 5 Use socket headed screws of strength class 10.9 minimum for magnetic way mounting screws. Do not use stainless steel screws.

Magnetic Way Model SGLTM-	L1 <sup>0.1</sup> <sub>0.3</sub>	L2	N	Approx. Mass kg
35324A□	324	270 (54×5)	6	4.8
35540A□	540	486 (54×9)	10	8
35756A□	756	702 (54×13)	14	11



## External Dimensions Units: mm

● Magnetic Way with Base: SGLTM-35□□□AY

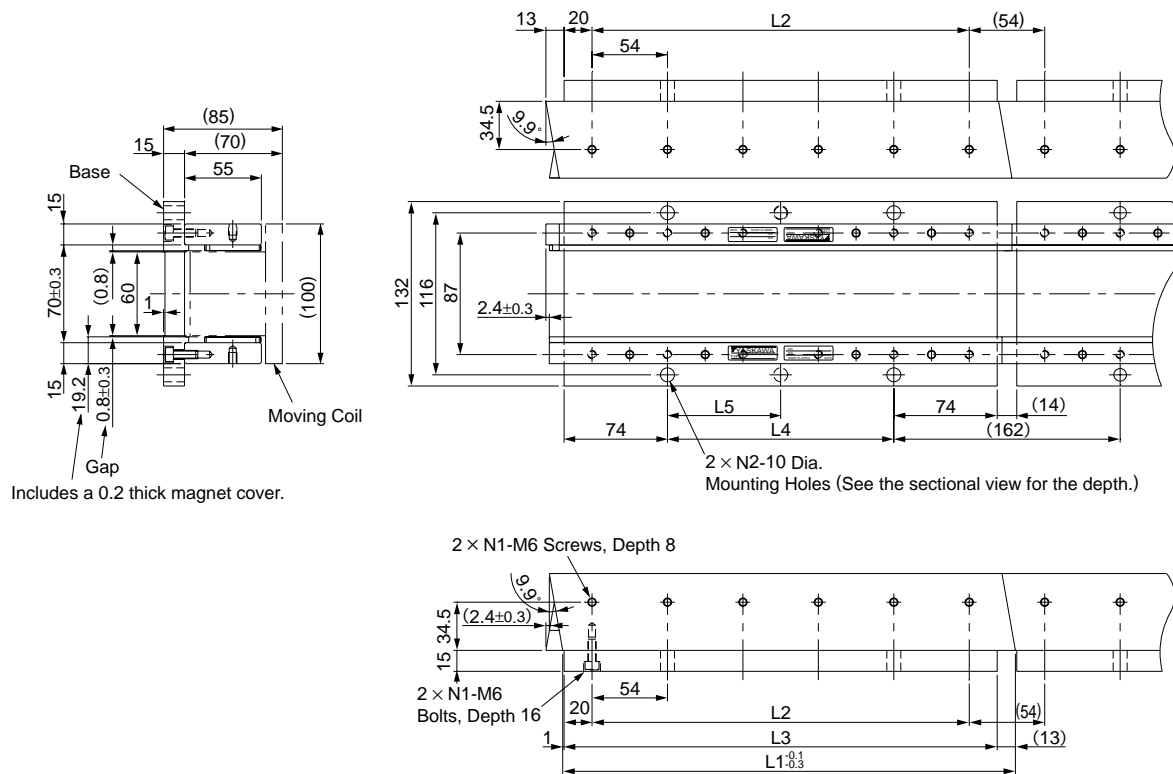

- Notes: 1 If you have a pacemaker or any other electronic medical device, do not go near the magnetic way of the linear servomotor.  
 2 Two magnetic ways in a set can be connected to each other.  
 3 The characteristics of the magnetic way with base are the same as of the magnetic way without base (SGLTM-35□□□A).

Magnetic Way Model SGLTM-	L1	L2	L3	L4	L5	N1	N2	Approx. Mass kg
35324AY	324	270	310	162	162	6	2	6.4
35540AY	540	486	526	378	189	10	3	11
35756AY	756	702	742	594	198	14	4	15

**External Dimensions** Units: mm

(3) Standard Type SGLTW-40

- Moving Coil: SGLTW-40□□□□B□ (With an MS connector)

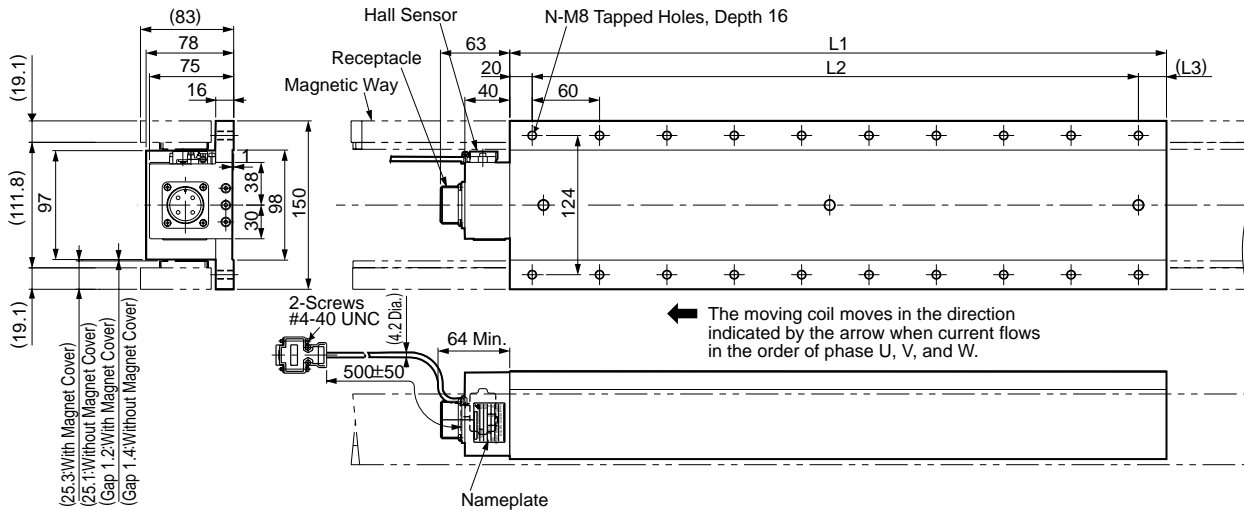

Hall Sensor Connector Specifications

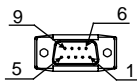

Pin Connector:  
17JE-23090-02 (D8C)  
by DDK Ltd.

The Mating Connector

Socket Connector:  
17JE-13090-02 (D8C)  
Stud: 17L-002C or  
17L-002C1

Pin No.	Signal
1	+5VDC
2	Phase U
3	Phase V
4	Phase W
5	0V
6	Not used
7	Not used
8	Not used
9	Not used

Linear Servomotor Connector Specifications



Receptacle type: MS3102A-22-22P  
□ by DDK Ltd.

The Mating Connector

L-shaped plug type : MS3108B22-22S  
Straight plug type : MS3106B22-22S  
Cable clamp type : MS3057-12A

Pin No.	Signal
A	Phase U
B	Phase V
C	Phase W
D	Ground

Hall Sensor Output Signals

When the moving coil moves in the direction indicated by the arrow in the figure, the relationship between the hall sensor output signals  $S_u$ ,  $S_v$ ,  $S_w$  and the inverse power of each motor phase  $V_u$ ,  $V_v$ ,  $V_w$  becomes as shown in the figure below.

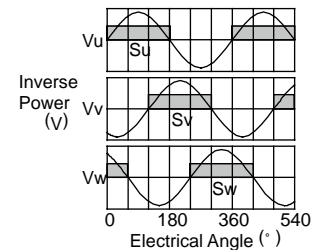

Moving Coil Model SGLTW-	L1	L2	(L3)	N	Approx. Mass kg
40□400B□	395	360(60×6)	(15)	14	15
40□600B□	575	540(60×9)	(15)	20	22

# External Dimensions Units: mm

• Magnetic Way : SGLTM-40□□□A□

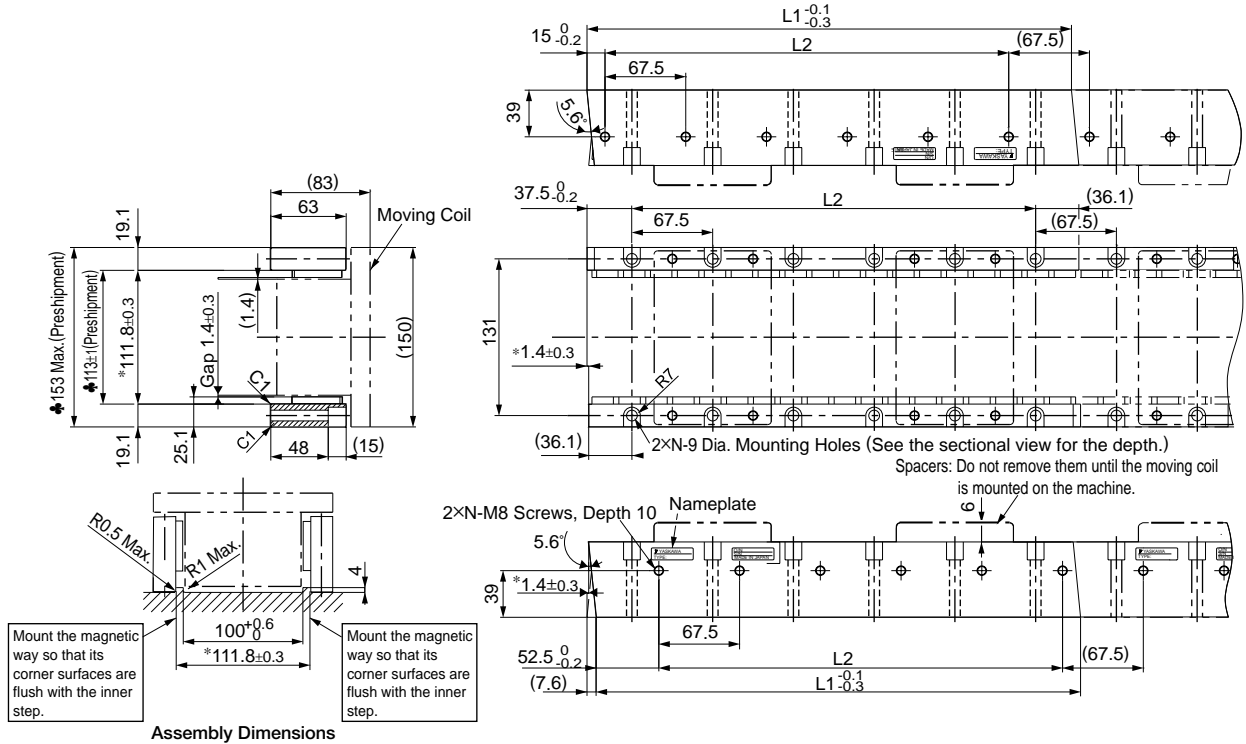

- Notes: 1 Two magnetic ways for both ends of moving coil make one set. Spacers are mounted on magnetic ways for safety during transportation. Do not remove the spacers until the moving coil is mounted on a machine.
- 2 If you have a pacemaker or any other electronic medical device, do not go near the magnetic way of the linear servomotor.
- 3 Two magnetic ways in a set can be connected to each other.
- 4 The dimensions marked with an \* are the dimensions between the magnetic ways. Be sure to follow exactly the dimensions specified in the figure above. Mount magnetic ways as shown in Assembly Dimensions. The values with a ♣ are the dimensions at preshipment.
- 5 Use socket headed screws of strength class 10.9 minimum for magnetic way mounting screws. Do not use stainless steel screws.

Magnetic Way Model SGLTM-	L1: <sup>0.1</sup> / <sub>0.3</sub>	L2	N	Approx. Mass kg
40405A□	405	337.5 (67.5×5)	6	9
40675A□	675	607.5 (67.5×9)	10	15
40945A□	945	877.5 (67.5×13)	14	21

**External Dimensions** Units: mm

- Magnetic Way with Base: SGLTM-40□□□AY

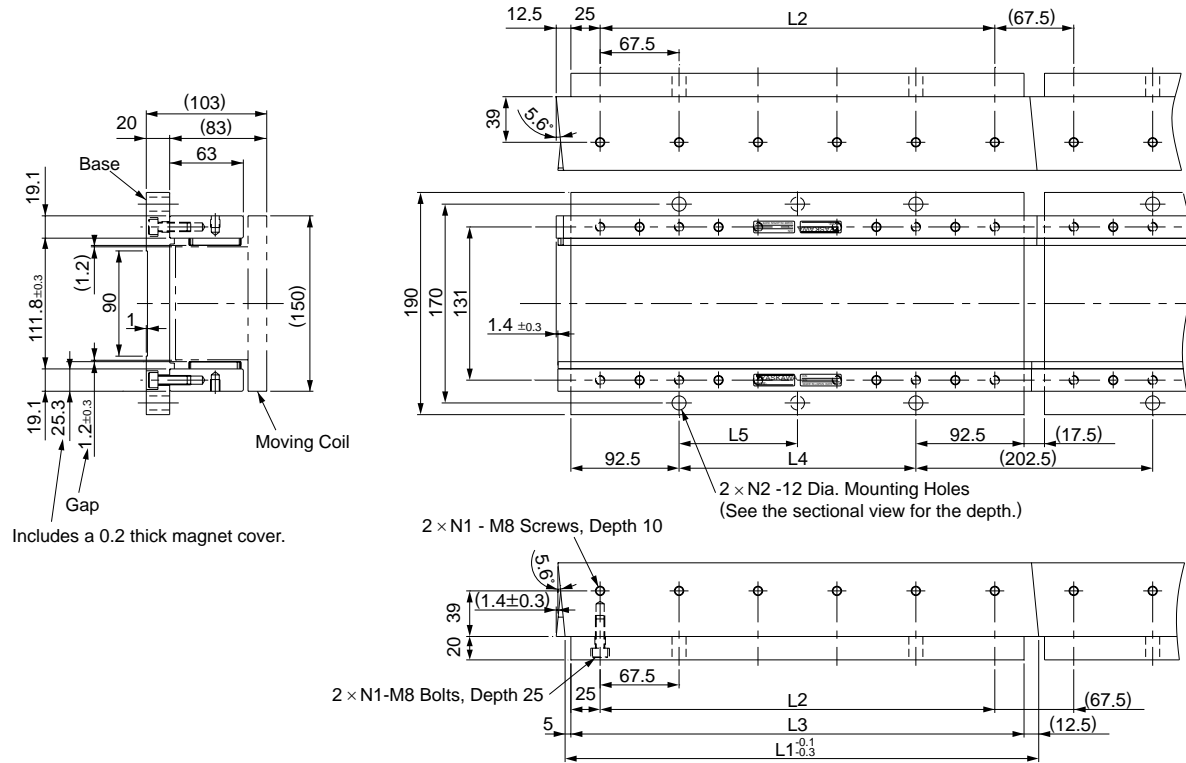

- Notes: 1 If you have a pacemaker or any other electronic medical device, do not go near the magnetic way of the linear servomotor.  
 2 Two magnetic ways in a set can be connected to each other.  
 3 The characteristics of the magnetic way with base are the same as of the magnetic way without base (SGLTM-40□□□A).

Magnetic Way Model SGLTM-	L1	L2	L3	L4	L5	N1	N2	Approx. Mass kg
40405AY	405	337.5	387.5	202.5	202.5	6	2	13
40675AY	675	607.5	657.5	472.5	236.25	10	3	21
40945AY	945	877.5	927.5	742.5	247.5	14	4	30

Linear Servomotors

# External Dimensions Units: mm

## (4) Standard Type SGLTW-80

- Moving Coil: SGLTW-80□□□□B□ (With an MS connector)

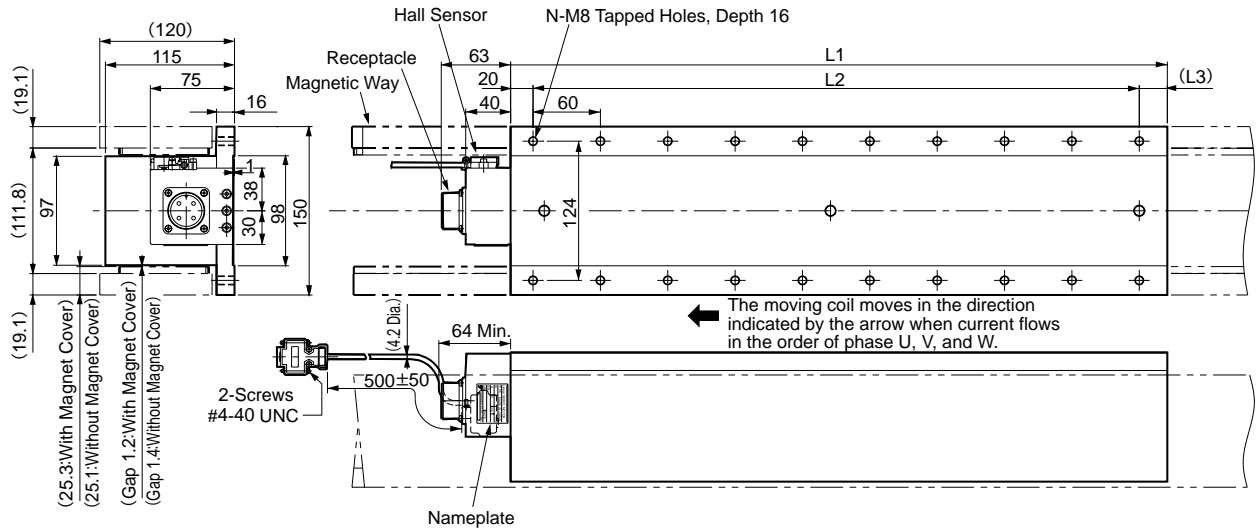

### Hall Sensor Connector Specifications

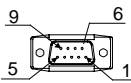

Pin Connector:  
17JE-23090-02 (D8C)  
by DDK Ltd.

### The Mating Connector

Socket Connector:  
17JE-13090-02 (D8C)  
Stud: 17L-002C or  
17L-002C1

Pin No.	Signal
1	+5VDC
2	Phase U
3	Phase V
4	Phase W
5	0V
6	Not used
7	Not used
8	Not used
9	Not used

### Linear Servomotor Connector Specifications



Receptacle type: MS3102A-22-22P  
by DDK Ltd.

### The Mating Connector

L-shaped plug type : MS3108B22-22S  
Straight plug type : MS3106B22-22S  
Cable clamp type : MS3057-12A

Pin No.	Signal
A	Phase U
B	Phase V
C	Phase W
D	Ground

### Hall Sensor Output Signals

When the moving coil moves in the direction indicated by the arrow in the figure, the relationship between the hall sensor output signals  $S_u$ ,  $S_v$ ,  $S_w$  and the inverse power of each motor phase  $V_u$ ,  $V_v$ ,  $V_w$  becomes as shown in the figure below.

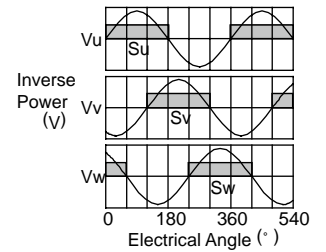

Moving Coil Model SGLTW-	L1	L2	L3	N	Approx. Mass kg
80□400B□	395	360(60×6)	(15)	14	24
80□600B□	575	540(60×9)	(15)	20	35

**External Dimensions** Units: mm

- Magnetic Way : SGLTM-80□□□A□

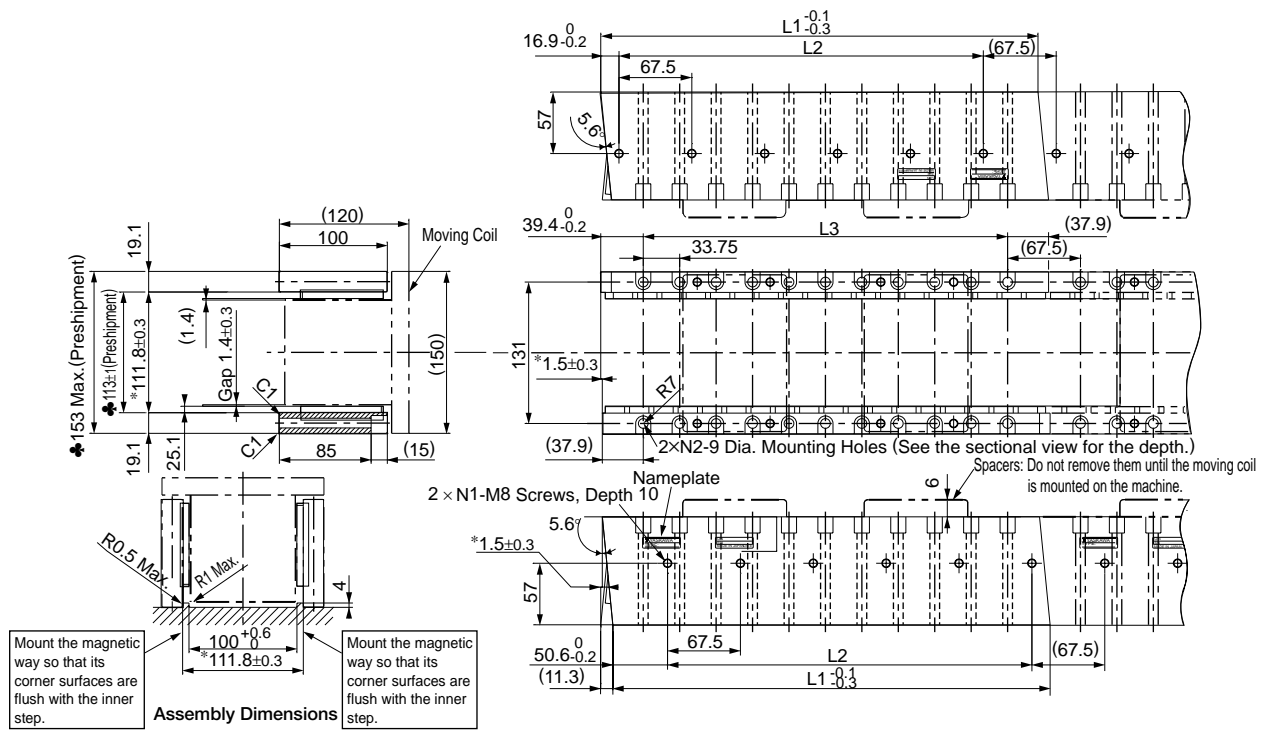

- Notes:
- 1 Two magnetic ways for both ends of moving coil make one set. Spacers are mounted on magnetic ways for safety during transportation. Do not remove the spacers until the moving coil is mounted on a machine.
  - 2 If you have a pacemaker or any other electronic medical device, do not go near the magnetic way of the linear servomotor.
  - 3 Two magnetic ways in a set can be connected to each other.
  - 4 The dimensions marked with an \* are the dimensions between the magnetic ways. Be sure to follow exactly the dimensions specified in the figure above. Mount magnetic ways as shown in Assembly Dimensions. The values with a ♣ are the dimensions at preshipment.
  - 5 Use socket headed screws of strength class 10.9 minimum for magnetic way mounting screws. Do not use stainless steel screws.

Magnetic Way Model SGLTM-	L1 <sup>-0.1</sup> <sub>-0.3</sub>	L2	L3	N1	N2	Approx. Mass kg
80405A□	405	337.5(67.5×5)	337.5(33.75×10)	6	11	14
80675A□	675	607.5(67.5×9)	607.5(33.75×18)	10	19	24
80945A□	945	877.5(67.5×13)	887.5(33.75×26)	14	27	34

Linear Servomotors

## External Dimensions Units: mm

● Magnetic Way with Base: SGLTM-80□□□AY

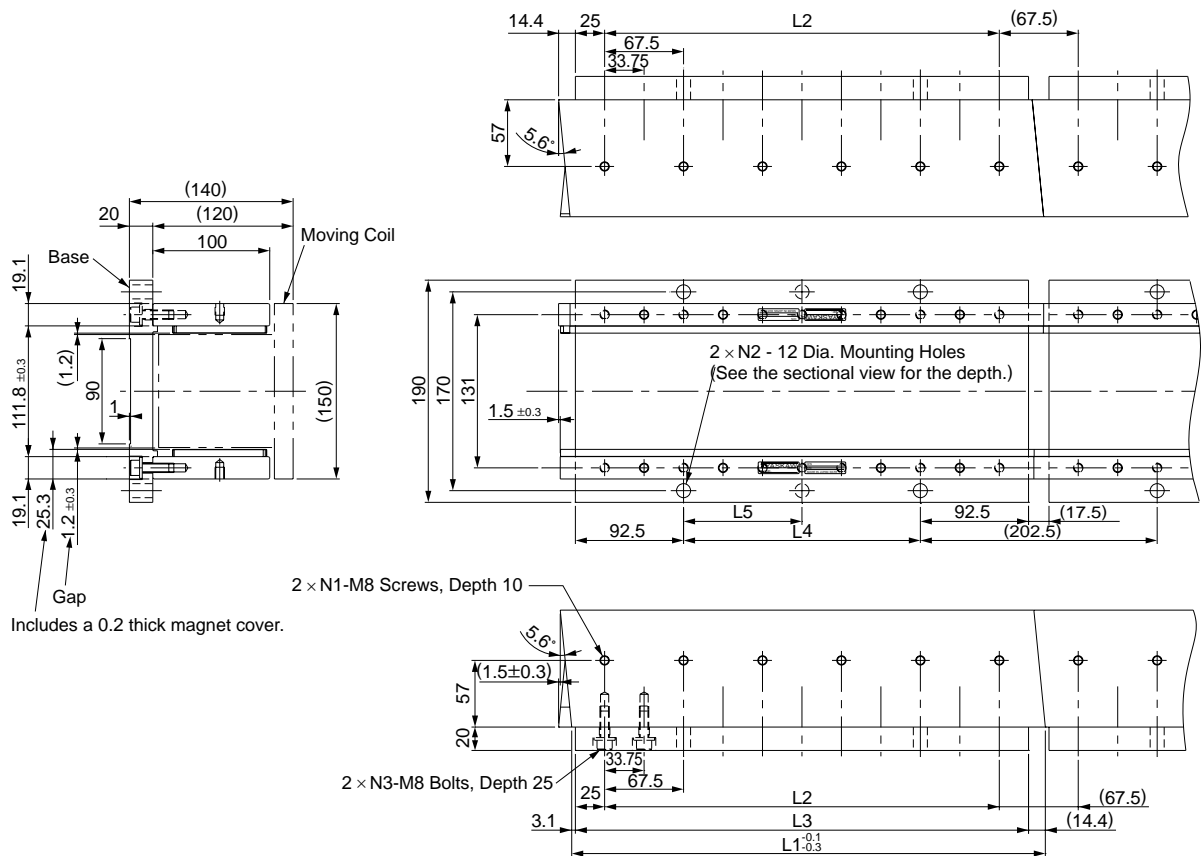

- Notes: 1 If you have a pacemaker or any other electronic medical device, do not go near the magnetic way of the linear servomotor.  
 2 Two magnetic ways in a set can be connected to each other.  
 3 The characteristics of the magnetic way with base are the same as of the magnetic way without base (SGLTM-80□□□A).

Magnetic Way Model SGLTM-	L1	L2	L3	L4	L5	N1	N2	N3	Approx. Mass kg
80405AY	405	337.5	387.5	202.5	202.5	6	2	11	18
80675AY	675	607.5	657.5	472.5	236.25	10	3	19	31
80945AY	945	877.5	927.5	742.5	247.5	14	4	27	43

**External Dimensions** Units: mm

(5) High-efficiency Type SGLTW-35A□□□H□

- Moving Coil: SGLTW-35A□□□H□ (With a connector by Tyco Electronics AMP K.K.)

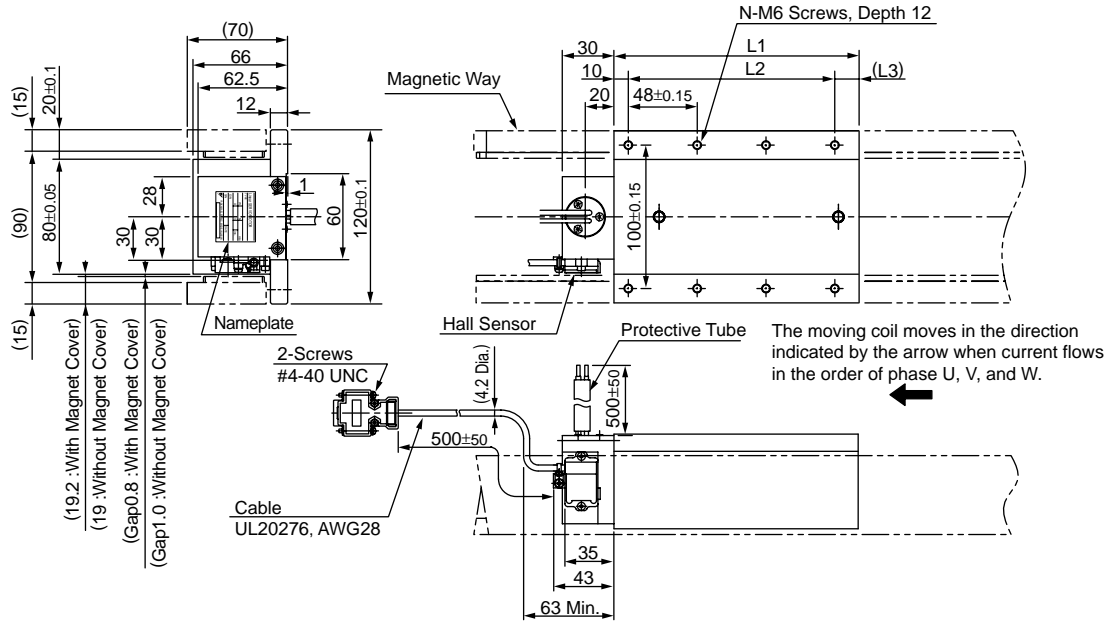

**Hall Sensor Connector Specifications**

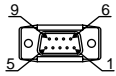

Pin Connector:  
17JE-23090-02 (D8C)  
by DDK Ltd.

The Mating Connector  
Socket Connector:  
17JE-13090-02 (D8C)  
Stud: 17L-002C or  
17L-002C1

Pin No.	Signal
1	+5VDC
2	Phase U
3	Phase V
4	Phase W
5	0V
6	Not used
7	Not used
8	Not used
9	Not used

**Lead Specifications of Moving Coil**

If this cable is bent repetitively, the cable will disconnect.

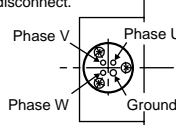

(View from Top of Moving Coil)

Name	Color	Code	Wire Size
Phase U		U	2 mm <sup>2</sup>
Phase V	Black	V	
Phase W		W	
Ground	Green	-	2 mm <sup>2</sup>

**Hall Sensor Output Signals**

When the moving coil moves in the direction indicated by the arrow in the figure, the relationship between the hall sensor output signals  $S_u$ ,  $S_v$ ,  $S_w$  and the inverse power of each motor phase  $V_u$ ,  $V_v$ ,  $V_w$  becomes as shown in the figure below.

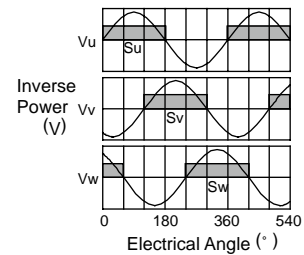

Moving Coil Model SGLTW-	L1	L2	(L3)	N	Approx. Mass kg
35A170H□	170	144 (48×3)	(16)	8	4.7
35A320H□	315	288 (48×6)	(17)	14	8.8



# External Dimensions Units: mm

- Moving Coil: SGLTW-35D□□□H□D (With a connector by Interconnectron GmbH)

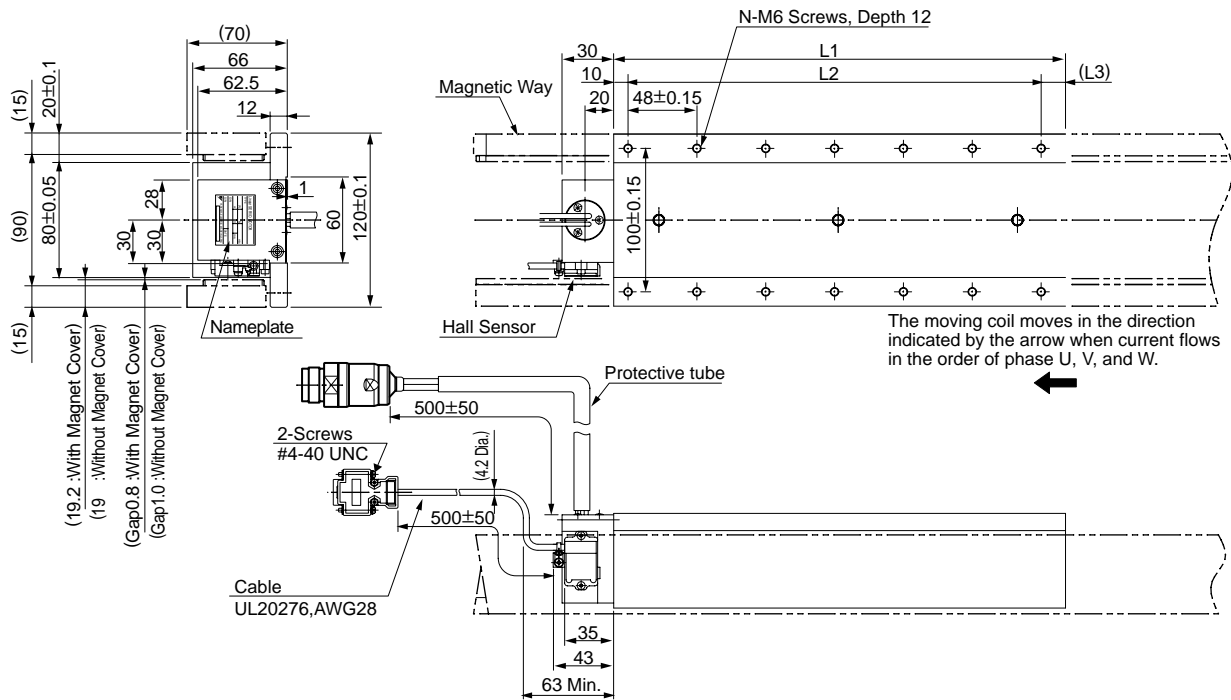

### Hall Sensor Connector Specifications

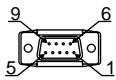

Pin Connector:  
17JE-23090-02 (D8C)  
by DDK Ltd.

The Mating Connector

Socket Connector:  
17JE-13090-02 (D8C)  
Stud: 17L-002C or  
17L-002C1

Pin No.	Signal
1	+5VDC
2	Phase U
3	Phase V
4	Phase W
5	0V
6	Not used
7	Not used
8	Not used
9	Not used

### Linear Servomotor Connector Specifications

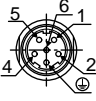

Extension : ARRA06AMRPN182  
Pin : 021.279.1020  
by Interconnectron GmbH

The Mating Connector

Plug : APRA06BFRDN170  
Socket : 020.105.1020

Pin No.	Signal
1	Phase U
2	Phase V
4	Phase W
5	Not used
6	Not used
⊕	Ground

### Hall Sensor Output Signals

When the moving coil moves in the direction indicated by the arrow in the figure, the relationship between the hall sensor output signals  $S_u$ ,  $S_v$ ,  $S_w$  and the inverse power of each motor phase  $V_u$ ,  $V_v$ ,  $V_w$  becomes as shown in the figure below.

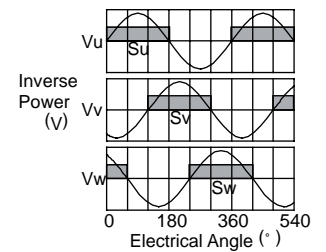

Moving Coil Model SGLTW-	L1	L2	(L3)	N	Approx. Mass kg
35D170H□D	170	144(48×3)	(16)	8	4.7
35D320H□D	315	288(48×6)	(17)	14	8.8

**External Dimensions** Units: mm

- Magnetic Way: SGLTM-35□□□H□

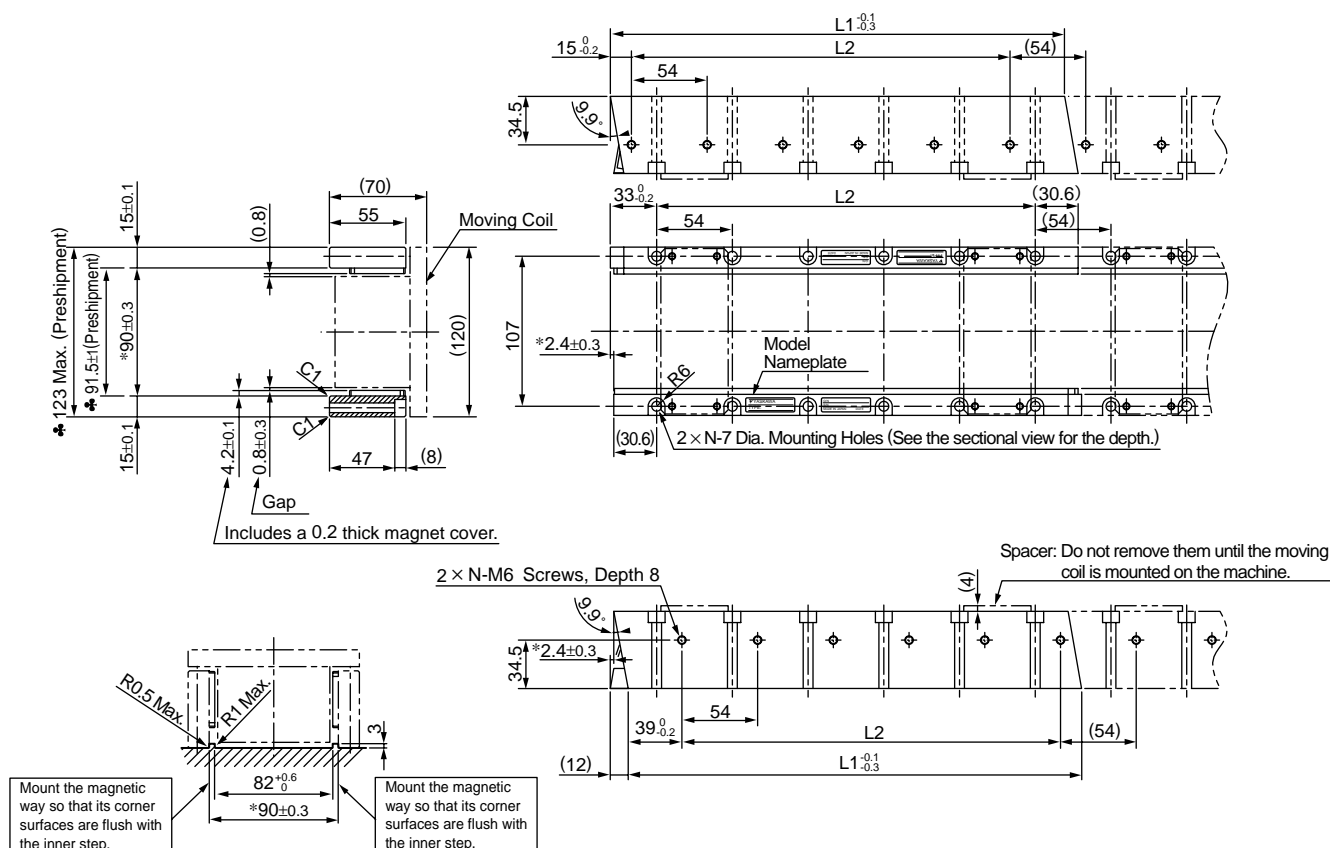

Assembly Dimensions

- Notes:
- 1 Two magnetic ways for both ends of moving coil make one set. Spacers are mounted on magnetic ways for safety during transportation. Do not remove the spacers until the moving coil is mounted on a machine.
  - 2 If you have a pacemaker or any other electronic medical device, do not go near the magnetic way of the linear servomotor.
  - 3 Two magnetic ways in a set can be connected to each other.
  - 4 The dimensions marked with an \* are the dimensions between the magnetic ways. Be sure to follow exactly the dimensions specified in the figure above. Mount magnetic ways as shown in Assembly Dimensions. The values with a ♣ are the dimensions at preshipment.
  - 5 Use socket headed screws of strength class 10.9 minimum for magnetic way mounting screws. Do not use stainless steel screws.

Magnetic Way Model SGLTM-	L1 <sup>-0.1</sup> <sub>-0.3</sub>	L2	N	Approx. Mass kg
35324H□	324	270 (54×5)	6	4.8
35540H□	540	486 (54×9)	10	8
35756H□	756	702 (54×13)	14	11

# External Dimensions Units: mm

## (6) High-efficiency Type SGLTW-50

- Moving Coil: SGLTW-50A□□□H□ (With a connector by Tyco Electronics AMP K.K.)

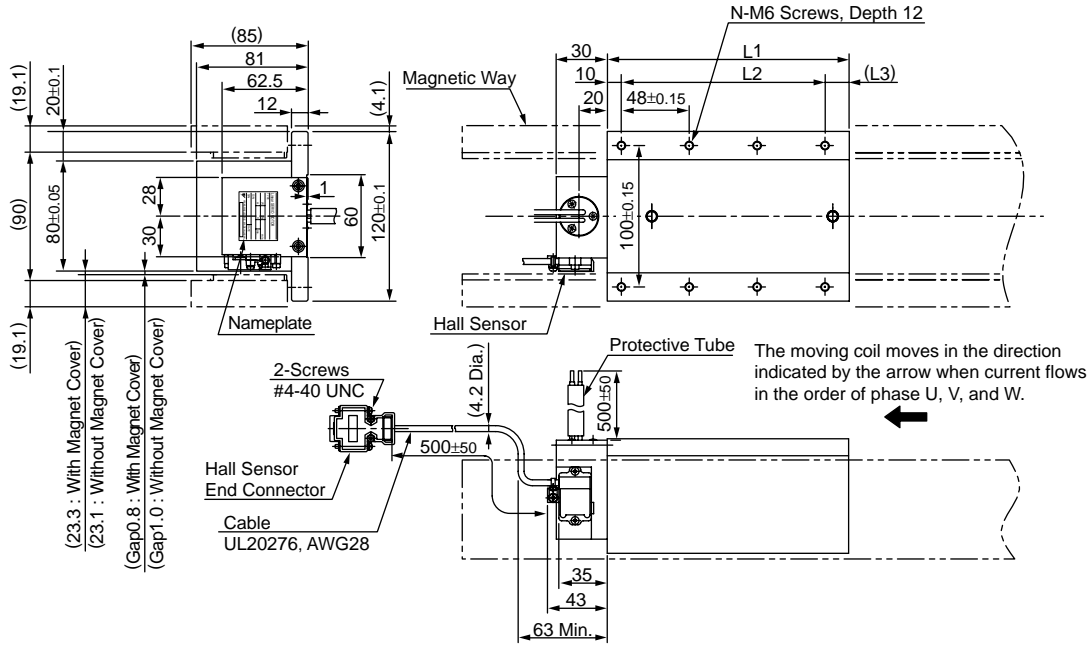

### Hall Sensor Connector Specifications

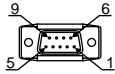

Pin Connector:  
17JE-23090-02 (D8C)  
by DDK Ltd.

The Mating Connector  
Socket Connector:  
17JE-13090-02 (D8C)  
Stud: 17L-002C or  
17L-002C1

Pin No.	Signal
1	+5VDC
2	Phase U
3	Phase V
4	Phase W
5	0V
6	Not used
7	Not used
8	Not used
9	Not used

### Lead Specifications of Moving Coil

- If this cable is bent repetitively, the cable will disconnect.

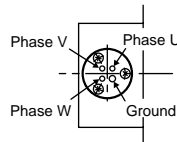

(View from Top of Moving Coil)

Name	Color	Code	Wire Size
Phase U		U	2 mm <sup>2</sup>
Phase V	Black	V	
Phase W		W	
Ground	Green	-	2 mm <sup>2</sup>

### Hall Sensor Output Signals

When the moving coil moves in the direction indicated by the arrow in the figure, the relationship between the hall sensor output signals  $S_u$ ,  $S_v$ ,  $S_w$  and the inverse power of each motor phase  $V_u$ ,  $V_v$ ,  $V_w$  becomes as shown in the figure below.

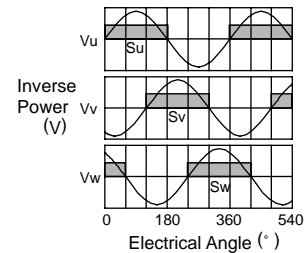

Moving Coil Model SGLTW-	L1	L2	(L3)	N	Approx. Mass kg
50A170H□	170	144 (48×3)	(16)	8	6
50A320□□	315	288 (48×6)	(17)	14	11

**External Dimensions** Units: mm

- Moving Coil: SGLTW-50D□□□H□D (With a connector by Interconnectron GmbH)

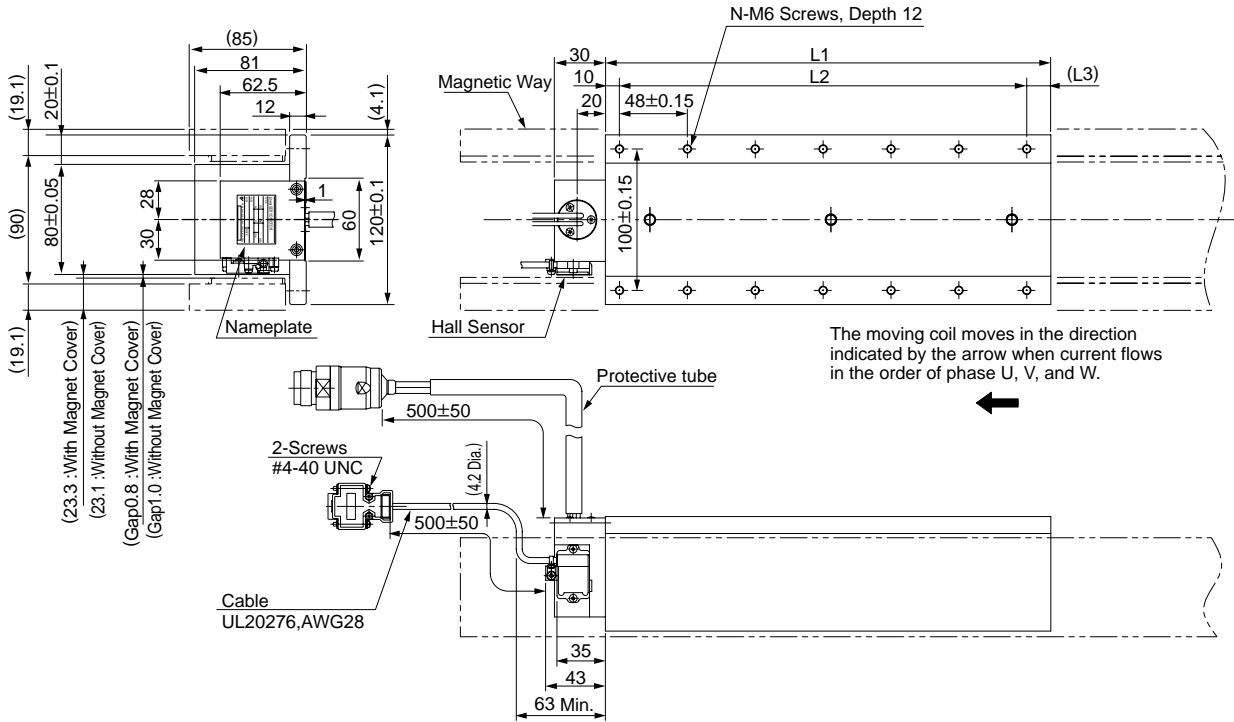

**Hall Sensor Connector Specifications**

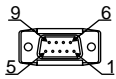

Pin Connector:  
17JE-23090-02 (D8C)  
by DDK Ltd.

**The Mating Connector**

Socket Connector:  
17JE-13090-02 (D8C)  
Stud: 17L-002C or  
17L-002C1

Pin No.	Signal
1	+5VDC
2	Phase U
3	Phase V
4	Phase W
5	0V
6	Not used
7	Not used
8	Not used
9	Not used

**Linear Servomotor Connector Specifications**



Extension : ARRA06AMRPN182  
Pin : 021.279.1020  
by Interconnectron GmbH

**The Mating Connector**

Plug : APRA06BFRDN170  
Socket : 020.105.1020

Pin No.	Signal
1	Phase U
2	Phase V
4	Phase W
5	Not used
6	Not used
⊕	Ground

**Hall Sensor Output Signals**

When the moving coil moves in the direction indicated by the arrow in the figure, the relationship between the hall sensor output signals  $S_u$ ,  $S_v$ ,  $S_w$  and the inverse power of each motor phase  $V_u$ ,  $V_v$ ,  $V_w$  becomes as shown in the figure below.

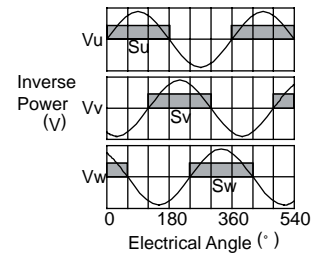

Moving Coil Model SGLTW-	L1	L2	(L3)	N	Approx. Mass kg
50D170H□D	170	144(48×3)	(16)	8	6
50D320H□D	315	288(48×6)	(17)	14	11

# External Dimensions Units: mm

- Magnetic Way: SGLTM-50□□□H□

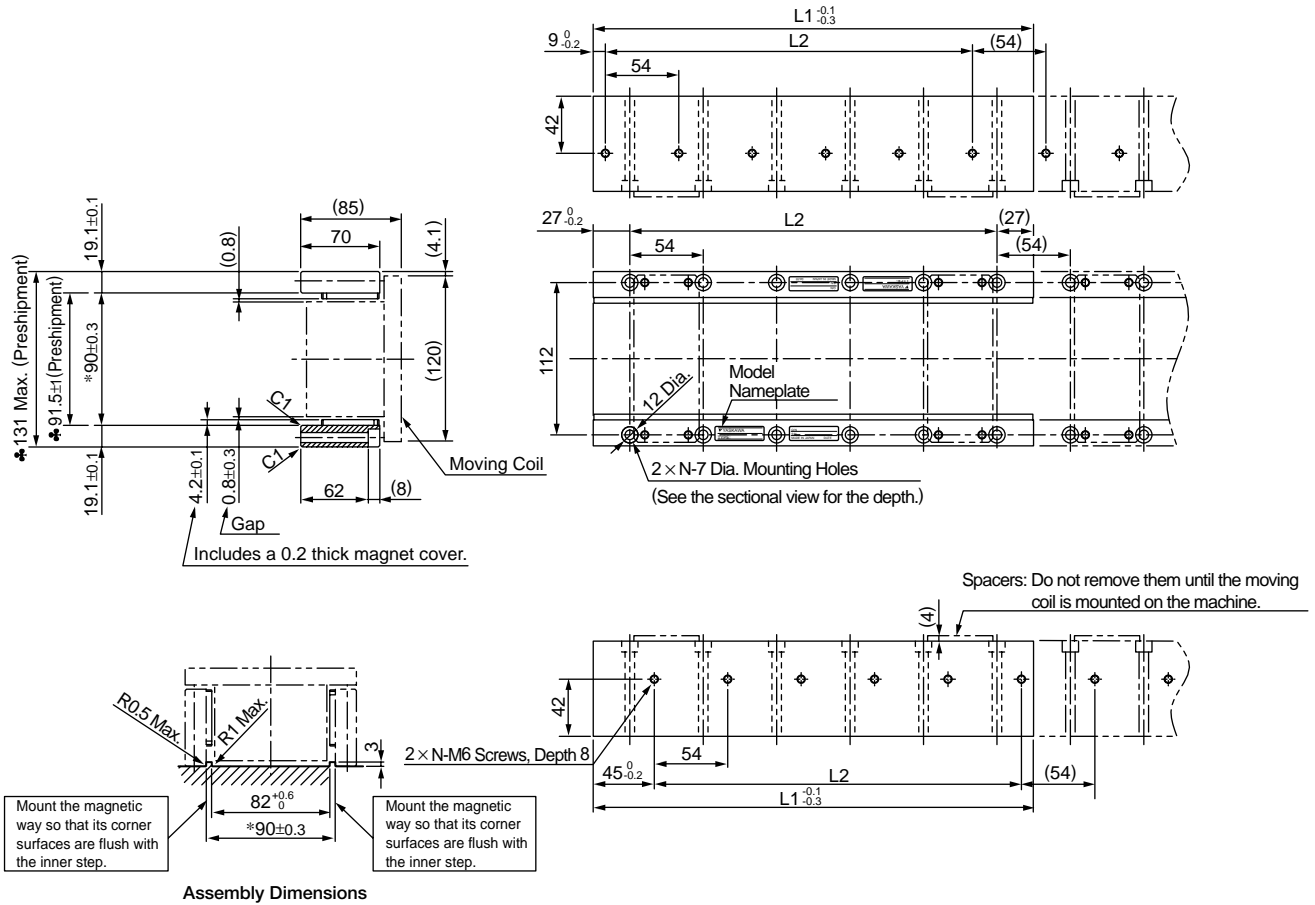

- Notes:
- 1 Two magnetic ways for both ends of moving coil make one set. Spacers are mounted on magnetic ways for safety during transportation. Do not remove the spacers until the moving coil is mounted on a machine.
  - 2 If you have a pacemaker or any other electronic medical device, do not go near the magnetic way of the linear servomotor.
  - 3 Two magnetic ways in a set can be connected to each other.
  - 4 The dimensions marked with an \* are the dimensions between the magnetic ways. Be sure to follow exactly the dimensions specified in the figure above. Mount magnetic ways as shown in Assembly Dimensions. The values with a ♣ are the dimensions at preshipment.
  - 5 Use socket headed screws of strength class 10.9 minimum for magnetic way mounting screws. Do not use stainless steel screws.

Magnetic Way Model SGLTM-	$L1_{-0.3}^{-0.1}$	$L2$	$N$	Approx. Mass kg
50324H□	324	270 (54×5)	6	8
50540H□	540	486 (54×9)	10	13
50756H□	756	702 (54×13)	14	18

Selecting Cables

● Cables Connections

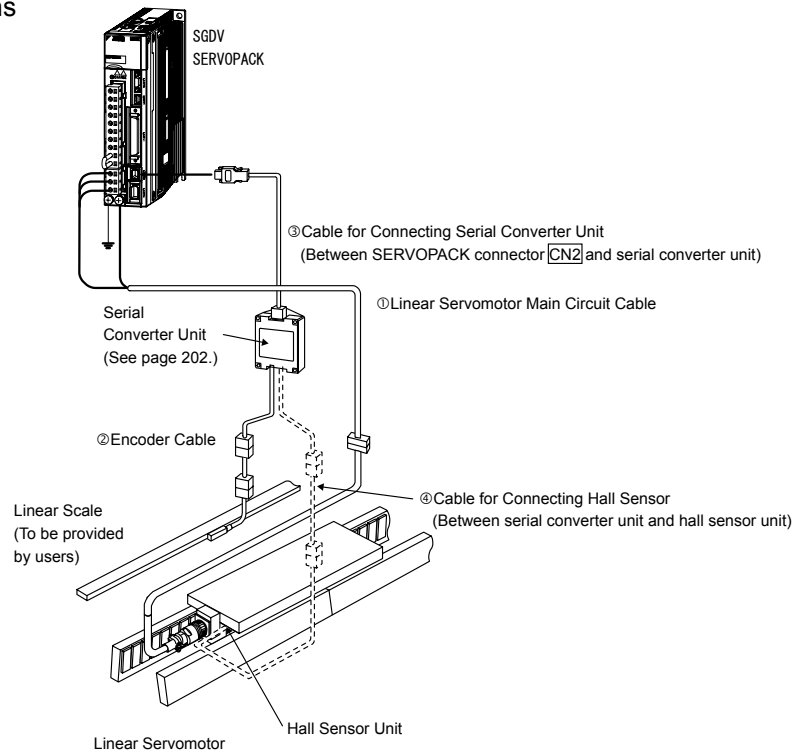

● Cables

Name	Applicable Linear Servomotor Model	Length	Order No.	Specifications	Details
① Linear Servomotor Main Circuit Cables	SGLTW -20, -35, -50	1 m	JZSP-CLN21-01-E		(1)
		3 m	JZSP-CLN21-03-E		
		5 m	JZSP-CLN21-05-E		
		10 m	JZSP-CLN21-10-E		
		15 m	JZSP-CLN21-15-E		
		20 m	JZSP-CLN21-20-E		
	SGLTW-40,-80	1 m	JZSP-CLN39-01-E		(2)
		3 m	JZSP-CLN39-03-E		
		5 m	JZSP-CLN39-05-E		
		10 m	JZSP-CLN39-10-E		
		15 m	JZSP-CLN39-15-E		
		20 m	JZSP-CLN39-20-E		
	SGLTW- □□A□□□□□D	1 m	JZSP-CLN14-01-E		(3)
		3 m	JZSP-CLN14-03-E		
		5 m	JZSP-CLN14-05-E		
		10 m	JZSP-CLN14-10-E		
		15 m	JZSP-CLN14-15-E		
		20 m	JZSP-CLN14-20-E		
	SGLTW- □□D□□□□□D	1 m	JZSP-CLN15-01-E		(4)
		3 m	JZSP-CLN15-03-E		
5 m		JZSP-CLN15-05-E			
10 m		JZSP-CLN15-10-E			
15 m		JZSP-CLN15-15-E			
20 m		JZSP-CLN15-20-E			

\*1: Connector by Tyco Electronics AMP K.K.

\*2: MS connector

\*3: Connector by Interconnectron GmbH

NOTE: Shaded items are non-stock.

(cont'd)

## Selecting Cables

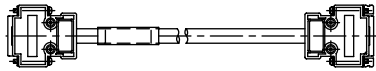
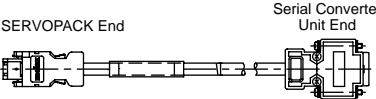
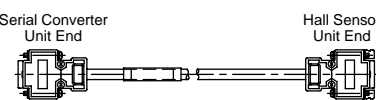
Name	Applicable Linear Servomotor Model	Length	Order No.	Specifications	Details
② Cables for Connecting Linear Scales*	All models	1 m	JZSP-CLL00-01-E		(5)
		3 m	JZSP-CLL00-03-E		
		5 m	JZSP-CLL00-05-E		
		10 m	JZSP-CLL00-10-E		
		15 m	JZSP-CLL00-15-E		
③ Cables for Connecting Serial Converter Units	All models	1 m	JZSP-CLP70-01-E		(6)
		3 m	JZSP-CLP70-03-E		
		5 m	JZSP-CLP70-05-E		
		10 m	JZSP-CLP70-10-E		
		15 m	JZSP-CLP70-15-E		
		20 m	JZSP-CLP70-20-E		
④ Cables for Connecting Hall Sensors	All models	1 m	JZSP-CLL10-01-E		(7)
		3 m	JZSP-CLL10-03-E		
		5 m	JZSP-CLL10-05-E		
		10 m	JZSP-CLL10-10-E		
		15 m	JZSP-CLL10-15-E		

\* When using serial converter unit JZSP-GD00□ - □□□ -E, the maximum cable length is 3 m.

### (1) Linear Servomotor Main Circuit Cables: JZSP-CLN21-□□-E

### ● Wiring Specifications

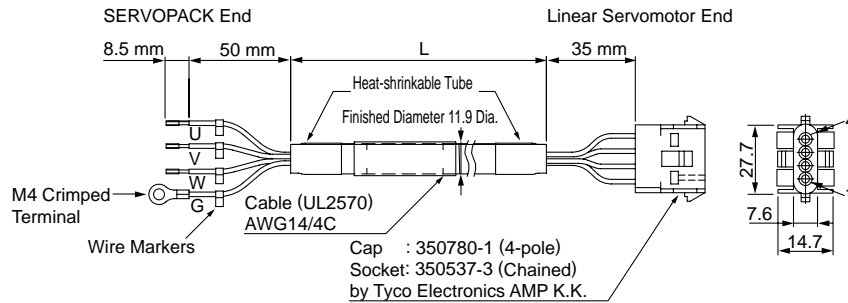

Wire Color	Signal	Signal	Pin No.
Red	Phase U	Phase U	1
White	Phase V	Phase V	2
Blue	Phase W	Phase W	3
Green/yellow	FG	FG	4

### (2) Linear Servomotor Main Circuit Cables: JZSP-CLN39-□□-E

A connector is not provided on the linear-servomotor end of the main circuit cable (JZSP-CLN39-□□-E). This connector is provided by the customer.

### ● Wiring Specifications

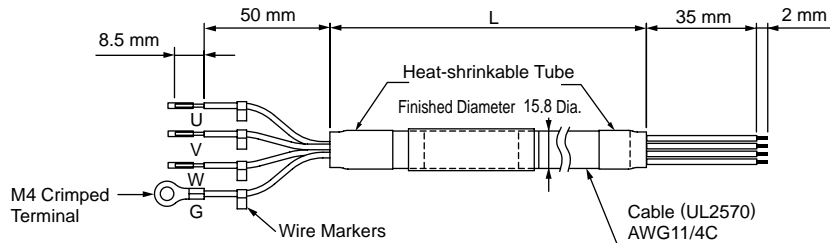

Wire Color	Signal	Signal	Pin No.
Red	Phase U	Phase U	1
White	Phase V	Phase V	2
Blue	Phase W	Phase W	3
Green/yellow	FG	FG	4

Selecting Cables

● JZSP-CLN39 Cable Connectors

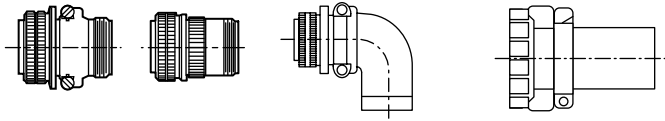

Applicable Linear Servomotor Model	Attached Connector	Plug		Cable Clamp
		Straight	Straight L-shaped	
SGLTW-40, -80	MS3102A22-22P	MS3106B22-22S or MS3106A22-22A	MS3108B22-22S	MS3057-12A

(a) MS3106B: Straight Plug with Front-shell and Back-shell Separated

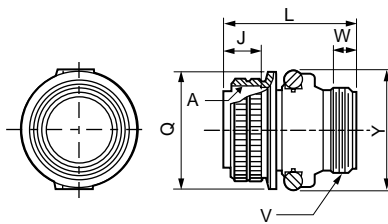

Units: mm

Shell Size	Joint Screw A	Joint Length J±0.12	Max. Overall Length L	Outer Diameter of Nut Q <sup>+0</sup> <sub>-0.38</sub>	Cable Clamp Mounting Screw V	Min. Effective Screw Length W	Max. Width Y
22	1 3/8 -18UNEF	18.26	55.57	40.48	1 3/16 -18UNEF	9.53	50

(b) MS3106A: Straight Plug with Solid Shell

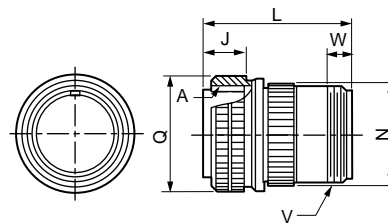

Units: mm

Shell Size	Joint Screw A	Joint Length J±0.12	Overall Length L±0.5	Outer Diameter of Nut Q <sup>+0</sup> <sub>-0.38</sub>	Outer Diameter N±0.5	Cable Clamp Mounting Screw V	Min. Effective Screw Length W
22	1 3/8 -18UNEF	18.26	54	40.48	34.99	1 3/16 -18UNEF	9.53

(c) MS3108B: L-shaped Plug with Front-shell and Back-shell Separated

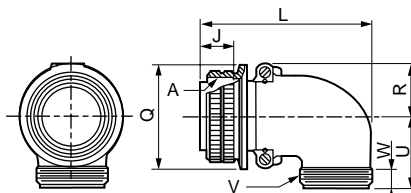

Units: mm

Shell Size	Joint Screw A	Joint Length J±0.12	Max. Overall Length L	R ±0.5	U ±0.5	Outer Diameter of Nut Q <sup>+0</sup> <sub>-0.38</sub>	Cable Clamp Mounting Screw V	Min. Effective Screw Length W
22	1 3/8 -18UNEF	18.26	76.98	24.1	33.3	40.48	1 3/16 -18UNEF	9.53

(d) MS3057-12A: Cable Clamp with Rubber Bushing

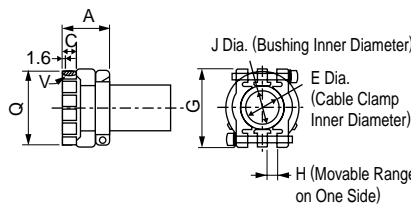

Units: mm

Applicable Shell Size	Overall Length A±0.7	Effective Screw Length C	E	G±0.7	H	J	Mounting Screw V	Outer Diameter Q±0.7	Rubber Bushing Type
20, 22	23.8	10.3	19.0	37.3	4.0	15.9	1 3/16 -18UNEF	35.0	AN3420 -12



## Selecting Cables

### (3) Linear Servomotor Main Circuit Cables: JZSP-CLN14-□□-E

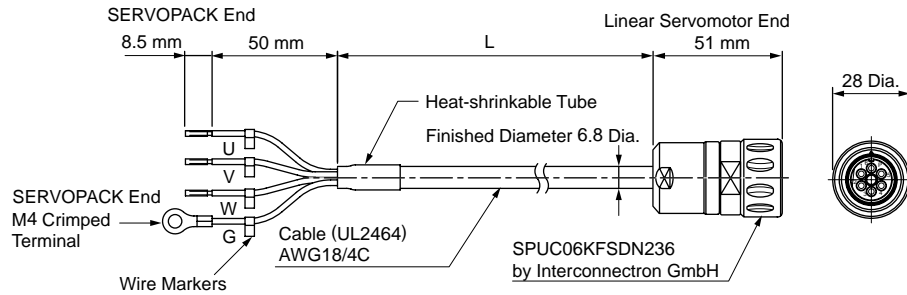

#### • Wiring Specifications

SERVOPACK-end Leads		Linear Servomotor-end Connector	
Wire Color	Signal	Signal	Pin No.
Black (White 1)	Phase U	Phase U	1
Black (White 2)	Phase V	Phase V	2
Black (White 3)	Phase W	Phase W	3
Green / yellow	FG	—	4
		—	5
		FG	6

### (4) Linear Servomotor Main Circuit Cables: JZSP-CLN15-□□-E

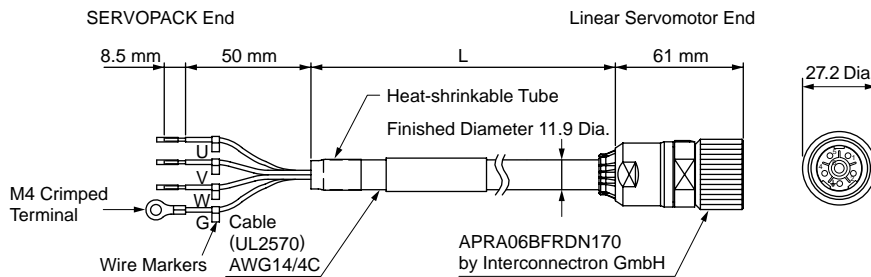

#### • Wiring Specifications

SERVOPACK-end Leads		Linear Servomotor-end Connector	
Wire Color	Signal	Signal	Pin No.
Red	Phase U	Phase U	1
White	Phase V	Phase V	2
Black	Phase W	FG	3
Green / yellow	FG	Phase W	4
		—	5
		—	6

### (2) Cables for Connecting Linear Scales: JZSP-CLL00-□□-E

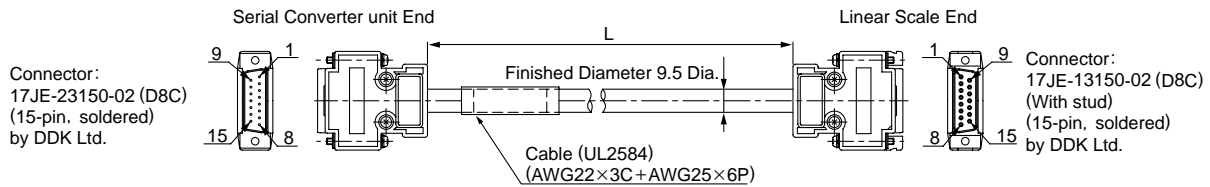

#### • Wiring Specifications

Serial Converter Unit End		Linear Scale End	
Pin No.	Signal	Pin No.	Signal
1	/Cos(V1-)	1	/Cos(V1-)
2	/Sin(V2-)	2	/Sin(V2-)
3	Ref(V0+)	3	Ref(V0+)
4	+5V	4	+5V
5	5Vs	5	5Vs
6	BID	6	BID
7	Vx	7	Vx
8	Vq	8	Vq
9	Cos(V1+)	9	Cos(V1+)
10	Sin(V2+)	10	Sin(V2+)
11	/Ref(V0+)	11	/Ref(V0-)
12	0V	12	0V
13	0Vs	13	0Vs
14	DIR	14	DIR
15	Inner	15	Inner
Case	Shield	Case	Shield

Selecting Cables

(6) Cables for Connecting Serial Converter Units: JZSP-CLP70-□□-E

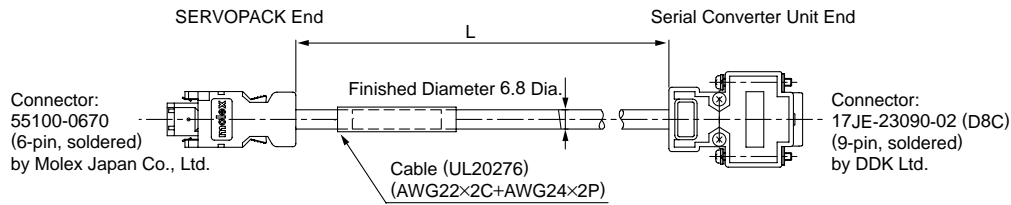

• Wiring Specifications

SERVOPACK End			Serial Converter Unit End		
Pin No.	Signal	Wire Color	Pin No.	Signal	Wire Color
1	PG5V	Red	1	+5V	Red
2	PG0V	Black	5	0V	Black
3	-	-	3	-	-
4	-	-	4	-	-
5	PS	Light blue	2	Phase S output	Light blue
6	/PS	Light blue/white	6	Phase /S output	Light blue/white
Shell	Shield	-	Case	Shield	-
			7	-	-
			8	-	-
			9	-	-

(7) Cables for Connecting Hall Sensors: JZSP-CLL10-□□-E

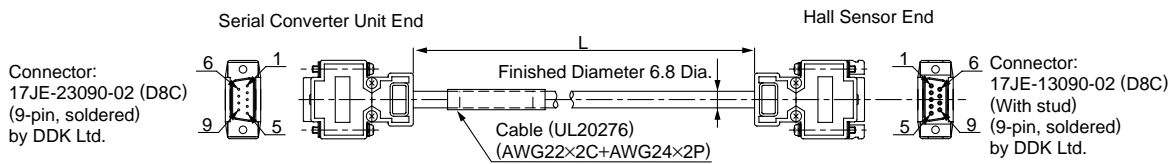

• Wiring Specifications

Serial Converter Unit End		Hall Sensor End	
Pin No.	Signal	Pin No.	Signal
1	+5V	1	+5V
2	Phase U input	2	Phase U input
3	Phase V input	3	Phase V input
4	Phase W input	4	Phase W input
5	0V	5	0V
6	-	6	-
7	-	7	-
8	-	8	-
9	-	9	-
Case	Shield	Case	Shield



# Linear Servomotor General Instructions

## Serial Converter Unit (Model: JZDP-□00□-□□□-E)

### ● Characteristics and Specifications

Items		JZDP-D00□-□□□-E	JZDP-G00□-□□□-E
Electrical Characteristics	Power Supply Voltage	+ 5.0V ± 5%, ripple content 5% max.	
	Current Consumption <sup>*1</sup>	120 mA Typ. 350 mA max.	
	Signal Resolution	Input two-phase sine wave: 1/256 pitch	Input two-phase sine wave: 1/4096 pitch
	Max. Response Frequency	250 kHz	100 kHz
	Analog Input Signals <sup>*2</sup> (cos, sin, Ref)	Differential input amplitude: 0.4 to 1.2 V Input signal level: 1.5 to 3.5 V	
	Hall Sensor Input Signal	CMOS level	
	Output Signals <sup>*3</sup>	Position data, hall sensor information, and alarms	
	Output Method	Serial data transmission	
	Output Circuit	Balanced transceiver (SN75LBC176 or the equivalent) Internal terminal resistance: 120 Ω	
Mechanical Characteristics	Approx. Mass	150 g	
	Vibration Resistance	98 m/s <sup>2</sup> max. (10 to 2500 Hz) in three directions	
	Impact Resistance	980 m/s <sup>2</sup> , (11 ms) two times in three directions	
Environmental Conditions	Ambient Temperature	0 to 55°C	
	Storage Temperature	-20 to +80°C	
	Humidity	20% to 90% RH (no condensation)	

- \*1: The current consumption of the linear scale and hall sensor is not included in this value.  
The current consumption of linear scale and hall sensor must be taken into consideration for the current capacity of host controller that supplies the power. The current consumption of hall sensor: Approx. 40 mA.
- \*2: Input a value within the specified range. Otherwise, incorrect position information is output, and the device may be damaged.
- \*3: The power is turned on, and the transmission is enabled after 100 ms to 300 ms.

Serial Converter Unit (Model: JZDP-□00□-□□□-E)

● Model Designations

JZDP - □00□ - □□□ - E

Serial Converter Unit Model			
Code	Appearance	Applicable Linear Scale	Hall Sensor
D003		Manufactured by HEIDENHAIN Corp.	None
G003			
D005		Manufactured by RENISHAW plc.	None
G005			
D006		Manufactured by HEIDENHAIN Corp.	Provided
G006			
D008		Manufactured by RENISHAW plc.	Provided
G008			

- Non-Stock Items
- Global Stock Items

Applicable Linear Servomotor						
Servomotor Model		Symbol	Servomotor Model		Symbol	
SGLGW- (Coreless)	30A050C	250	SGLTW- (Iron core, T-type)	20A170A	011	
	30A080C	251		20A320A	012	
	40A140C	252		20A460A	013	
	40A253C	253		35A170A	014	
	40A365C	254		35A320A	015	
	When a standard-force magnetic way is used.	60A140C		258	35A460A	016
		60A253C		259	35A170H	105
		60A365C		260	35A320H	106
		90A200C		264	50A170H	108
		90A370C		265	50A320H	109
		90A535C		266	40A400B	185
	SGLGW- + SGLGM- □-M (Coreless)	40A140C		255	40A600B	186
40A253C		256	80A400B	187		
40A365C		257	80A600B	188		
60A140C		261	35D170H	193		
60A253C		262	35D320H	194		
60A365C		263	50D170H	195		
SGLFW- (Iron core, F-type)	20A090A	017	50D320H	196		
	20A120A	018	40D400B	197		
	35A120A	019	40D600B	198		
	35A230A	020	80D400B	199		
	50A200B	181	80D600B	200		
	50A380B	182				
	1ZA200B	183				
	1ZA380B	184				
	35D120A	211				
	35D230A	212				
	50D200B	189				
	50D380B	190				
	1ZD200B	191				
	1ZD380B	192				

Linear Servomotor General Instructions

● Analog Signal Input Timing

The following figure shows the input timing of the analog signals.

When the cos and sin signals are shifted 180 degrees, the differential signals are the /cos and /sin signals.

The specifications of the cos, /cos, sin, and /sin signals are identical except for the phase.

Input the signals Ref and /Ref so that they shall cross each other as shown in the figure because they are input into the converter. When they are crossed, the output data will be counted up.

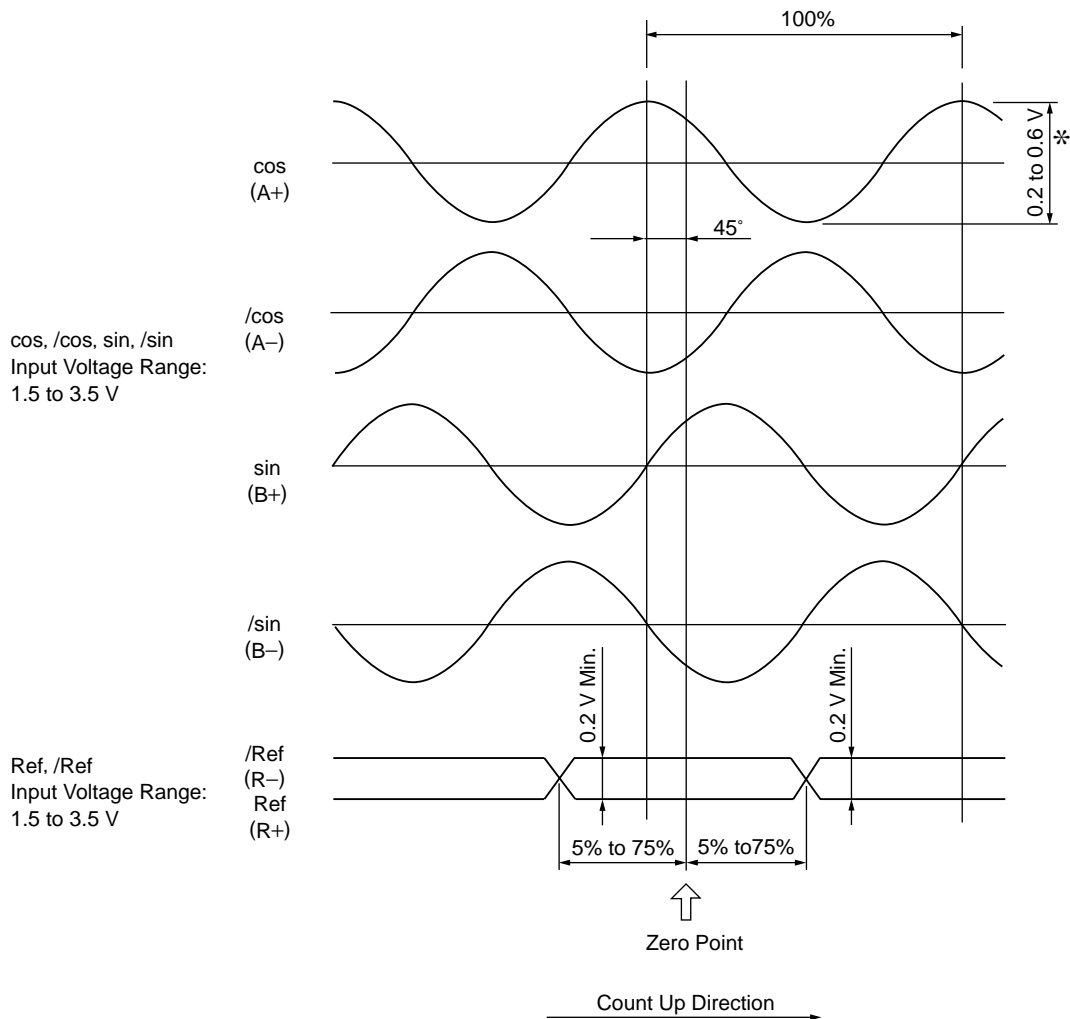

\*:If the analog signal amplitude declines to about 0.35 V because of differential amplitude, the serial converter outputs an alarm.

IMPORTANT

■ Precautions

- 1 Never perform insulation resistance and withstand voltage tests.
- 2 When analog signals are input to the serial converter unit, noise influence on the analog signals affects the unit's ability to output correct position information. The analog cable must be as short as possible and shielded.
- 3 Use the serial converter unit without gases such as H<sub>2</sub>S.
- 4 Do not connect or disconnect the unit while power is being supplied, or the unit may be damaged.
- 5 When using multiple axes, use a shield cable for each axis. Do not use a shield cable for multiple axes.

## Serial Converter Unit (Model: JZDP-□00□-□□□-E) Units: mm

### ● Without Cable for Hall Sensor (For Linear Scale by HEIDENHAIN Corporation)

Serial Converter Unit Model: JZDP-□003-□□□-E

#### (1) Connection Example

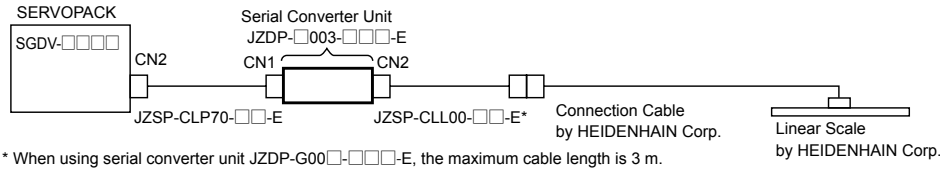

#### (2) External Dimensions

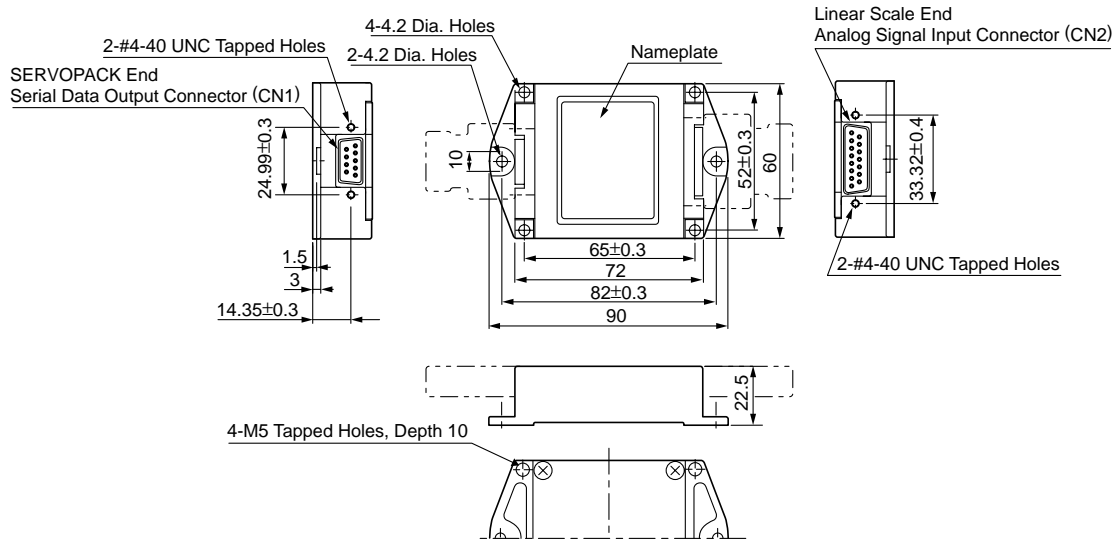

Pin No.	Signal
1	+5V
2	Phase S output
3	Not used
4	Not used
5	0V
6	Phase /S output
7	Not used
8	Not used
9	Not used
Case	Shield

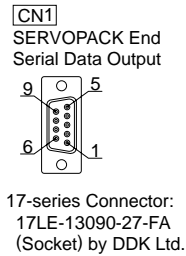

Pin No.	Signal
1	cos input (A+)
2	0V
3	sin input (B+)
4	+5V
5	Not used
6	Not used
7	/Ref input (R-)
8	Not used
9	/cos input (A-)
10	0V sensor
11	/sin input (B-)
12	5V sensor
13	Not used
14	Ref input (R+)
15	Not used
Case	Shield

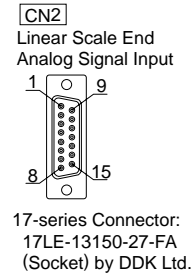

- Notes:
- 1 Do not use the unused pins.
  - 2 Contact HEIDENHAIN Corporation for details of connection cables (analog 1 Vp-p output, D-sub 15-pin, male) by HEIDENHAIN Corporation.
  - 3 Use the same terminal for 5-V sensor and phase-W input.
  - 4 Phase U, V, and W input are internally pulled up at 10 kΩ.

# Serial Converter Unit (Model: JZDP-□00□-□□□-E) Units: mm

## ● Without Cable for Hall Sensor (For Linear Scale by Renishaw plc.)

Serial Converter Unit Model: JZDP-□005-□□□-E

### (1) Connection Example

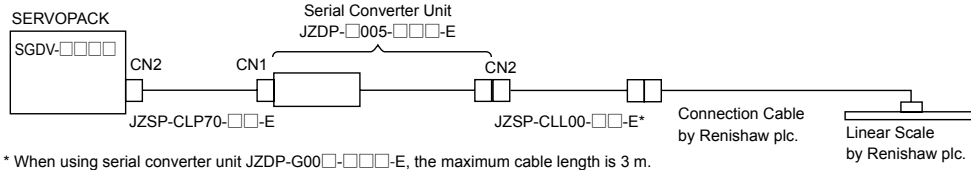

### (2) External Dimensions

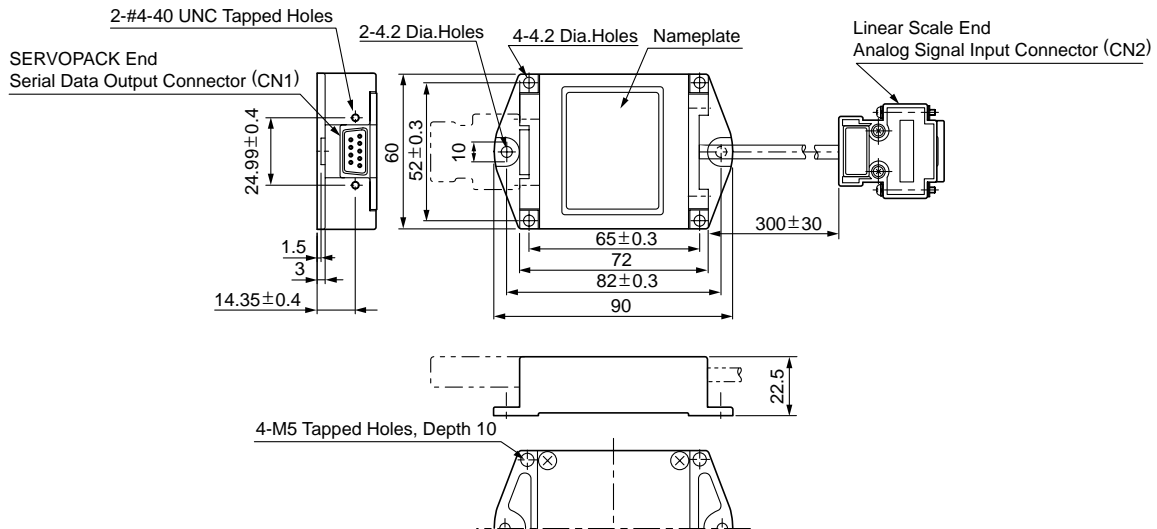

Pin No.	Signal
1	+5V
2	Phase S output
3	Not used
4	Not used
5	0V
6	Phase /S output
7	Not used
8	Not used
9	Not used
Case	Shield

SERVOPACK does not have the function to process Vq signals.

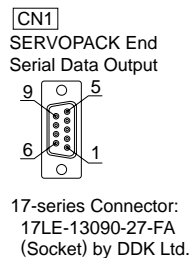

Pin No.	Signal
1	cos input (V1-)
2	sin input (V2-)
3	Ref input (V0+)
4	+5V
5	5Vs
6	Not used
7	Not used
8	Not used
9	cos input (V1+)
10	sin input (V2+)
11	/Ref input (V0-)
12	0V
13	0Vs
14	Not used
15	inner (0V)
Case	Shield

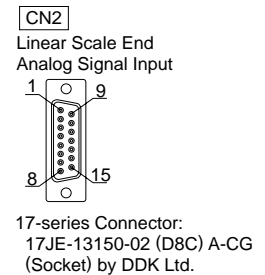

- Notes:
- 1 Do not use the unused pins.
  - 2 Contact Renishaw plc. for details of connection cables (analog 1 Vp-p output, D-sub 15-pin, male) by Renishaw plc. However, the BID and DIR signals are not connected.
  - 3 Use the linear scale-end connector to change the zero point specifications of the linear scale.

## Serial Converter Unit (Model: JZDP-□00□-□□□-E) Units: mm

### ● With Cable for Hall Sensor (For Linear Scale by HEIDENHAIN Corporation)

Serial Converter Unit Model: JZDP-□006-□□□-E

#### (1) Connection Example

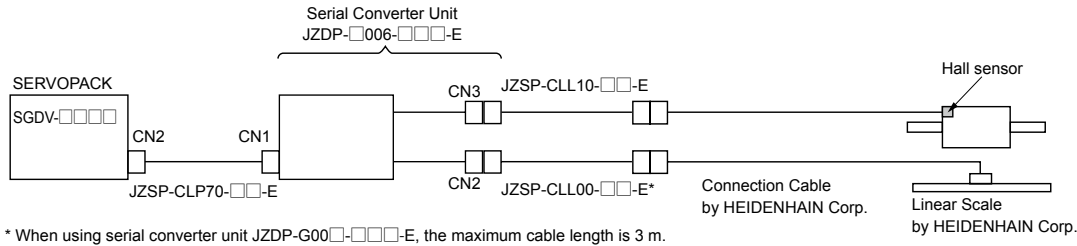

#### (2) External Dimensions

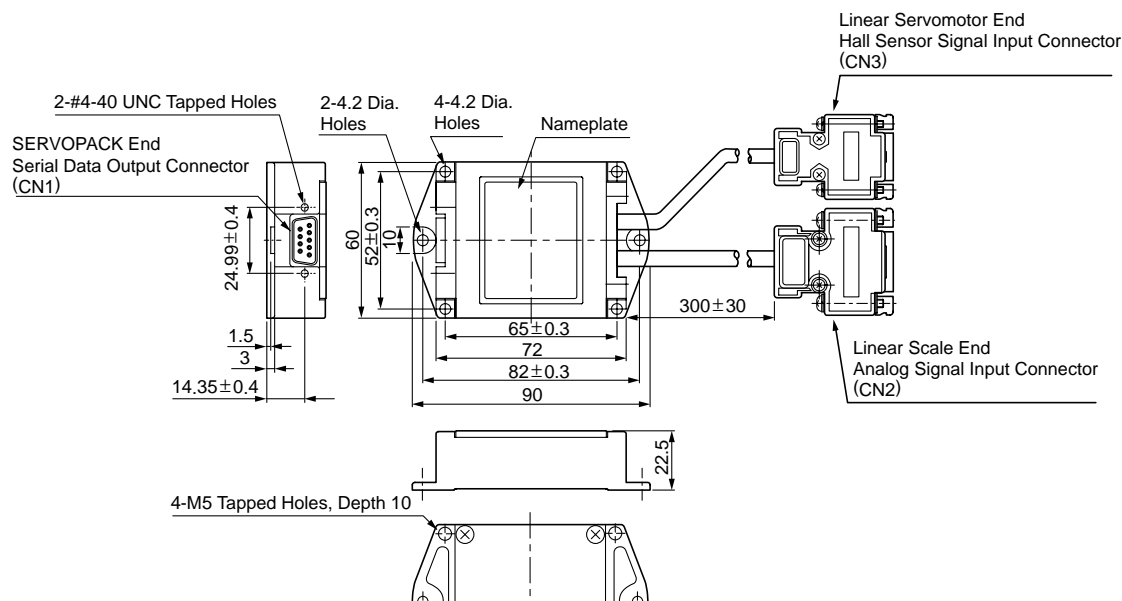

**CN1**  
SERVOPACK End  
Serial Data Output

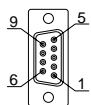

17-series Connector:  
17LE-13090-27-FA  
(Socket) by DDK Ltd.

Pin No.	Signal
1	+5V
2	Phase S output
3	Not used
4	Not used
5	0V
6	Phase /S output
7	Not used
8	Not used
9	Not used
Case	Shield

**CN2**  
Linear Scale End  
Analog Signal Input

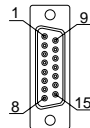

17-series Connector:  
17JE-13150-02 (D8C) A-CG  
(Socket) by DDK Ltd.

Pin No.	Signal
1	cos input (A+)
2	0V
3	sin input (B+)
4	+5V
5	Not used
6	Not used
7	/Ref input (R-)
8	Not used
9	/cos input (A-)
10	0V sensor
11	/sin input (B-)
12	5V sensor
13	Not used
14	Ref input (R+)
15	Not used
Case	Shield

**CN3**  
Linear Servomotor End  
Hall Sensor Signal Input

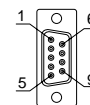

17-series Connector:  
17JE-13090-02 (D8C) A-CG  
by DDK Ltd.

Pin No.	Signal
1	+5V
2	Phase U input
3	Phase V input
4	Phase W input
5	0V
6	Not used
7	Not used
8	Not used
9	Not used
Case	Shield

- Notes: 1 Do not use the unused pins.  
2 Contact HEIDENHAIN Corporation for details of connection cables (analog 1 Vp-p output, D-sub 15-pin, male) by HEIDENHAIN Corporation.  
3 Phase U, V, and W input are internally pulled up at 10 kΩ.



# Serial Converter Unit (Model: JZDP-□00□-□□□-E) Units: mm

## ● With Cable for Hall Sensor (For Linear Scale by Renishaw plc.)

Serial Converter Unit Model: JZDP-□008-□□□-E

### (1) Connection Example

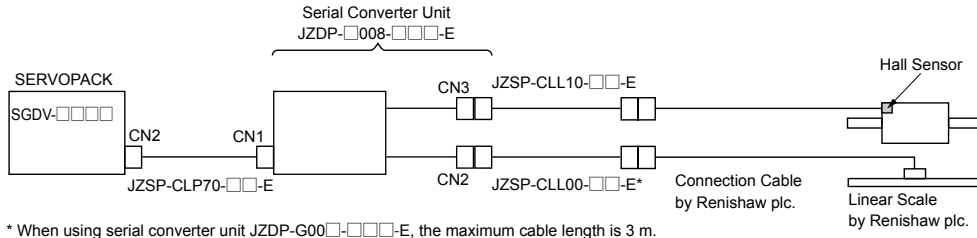

### (2) External Dimensions

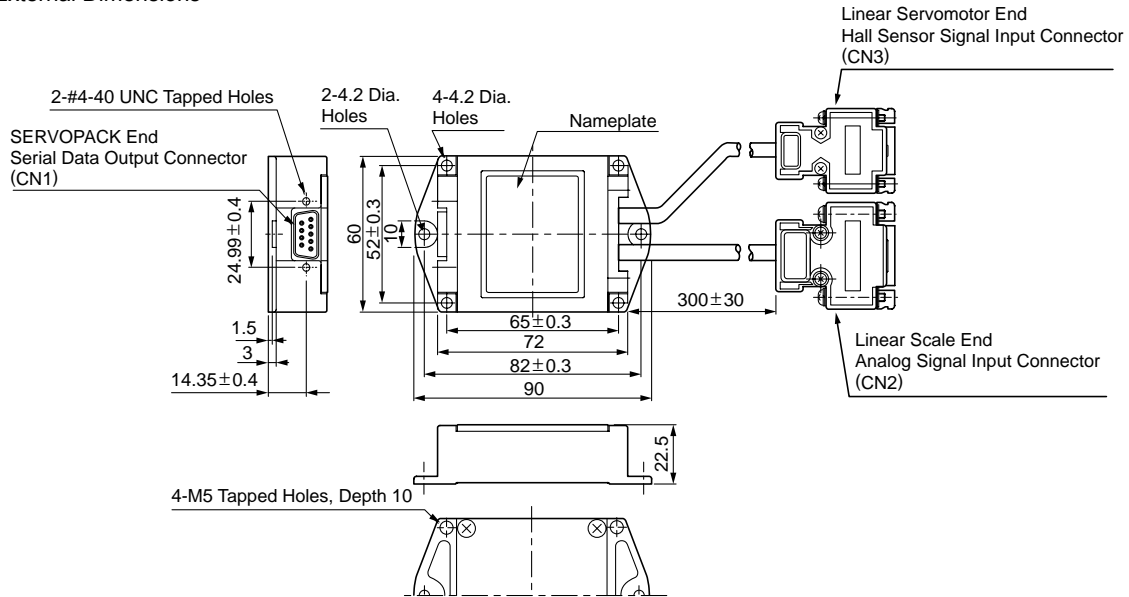

**CN1**  
SERVOPACK End  
Serial Data Output

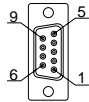

17-series Connector:  
17LE-13090-27-FA  
(Socket) by DDK Ltd.

**CN2**  
Linear Scale End  
Analog Signal Input

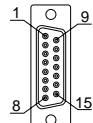

17-series Connector:  
17JE-13150-02 (D8C) A-CG  
(Socket) by DDK Ltd.

**CN3**  
Linear Servomotor End  
Hall Sensor Signal Input

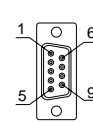

17-series Connector:  
17JE-13090-02 (D8C) A-CG  
by DDK Ltd.

Pin No.	Signal
1	+5V
2	Phase S output
3	Not used
4	Not used
5	0V
6	Phase /S output
7	Not used
8	Not used
9	Not used
Case	Shield

Pin No.	Signal
1	/cos input (V1-)
2	/sin input (V2-)
3	Ref input (V0+)
4	+5V
5	5Vs
6	Not used
7	Not used
8	Not used
9	cos input (V1+)
10	sin input (V2+)
11	/Ref input (V0-)
12	0 V
13	0 Vs
14	Not used
15	Inner
Case	Shield

Pin No.	Signal
1	+5V
2	Phase U input
3	Phase V input
4	Phase W input
5	0V
6	Not used
7	Not used
8	Not used
9	Not used
Case	Shield

- Notes:
- Do not use the unused pins.
  - Contact Renishaw plc. for details of connection cables (analog 1 Vp-p output, D-sub 15-pin, male) by Renishaw plc. However, the BID and DIR signals are not connected.
  - Use the linear scale-end connector to change the zero point specifications of the linear scale.
  - Phase U, V, and W input are internally pulled up at 10 kΩ.

## Flexible Cables

### ● Life of Flexible Cable

The flexible cable supports 10,000,000 or more operations of bending life with the recommended bending radius R. The following table shows the recommended bending radius R of each cable.

Cable Type	Model	Recommended Bending Radius mm
Linear Servomotor Main Circuit Cables	JZSP-CLN11-□□-E	35
	JZSP-CLN21-□□-E	38
	JZSP-CLN39-□□-E	50
	JZSP-CLN14-□□-E	35
Cables for Connecting Linear Scales	JZSP-CLL00-□□-E	57
Cables for Connecting Hall Sensors	JZSP-CLL10-□□-E	46
Cables for Connecting Serial Converter Units	JZSP-CLP70-□□-E	46

### ● Conditions

- 1 Repeat moving one end of the cable forward and backward for 320 mm with using the test equipment shown in the following figure.
- 2 Connect the lead wires in parallel, and count the number of cable return motion until a lead wire is disconnected. Note that one reciprocating is counted as one test.

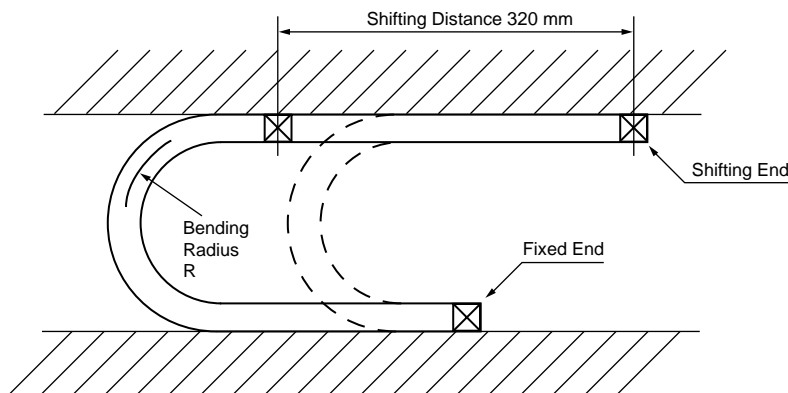

- Notes:
- 1 The life of flexible cable differs largely depending on the amount of mechanical shocks, mounting to the cable, and fixing methods. The life of flexible cable is limited under the specified conditions.
  - 2 The life of flexible cable indicates the number of bending times in which lead wires are electrically conducted and by which no cracks and damages that affects the performance of cable sheathing are caused. Disconnecting the shield wire is not taken into account.

### ● Wiring Precautions

Even if the recommended bending radius R is respected in the mechanical design, incorrect wiring may cause early disconnection. Observe the following precautions when wiring.

- (1) Cable twisting  
Straighten the flexible cables before wiring.  
Twisted cables cause early disconnection. Check the indication on the cable surface to make sure that the cable is not twisted.
- (2) Fixing method  
Do not fix the moving points of the flexible cable. Stress on the fixed points may cause early disconnection. Fix the cable at the minimum number of points.
- (3) Cable length  
If the cable length is too long, it may cause the cable's sagging. Besides the cable length is too short, it may cause the excessive tension on the fixed points that will cause early disconnection. Use a flexible cable with the optimum length.
- (4) Interference between cables  
Avoid interference between cables.  
Interference limits the motion of flexible cable, which causes early disconnection. Keep enough distance between cables, or provide a partition when wiring.

# Linear Slides

# $\Sigma$ -Trac

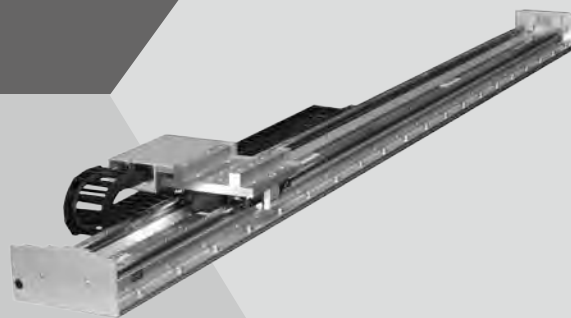

## Model Designation

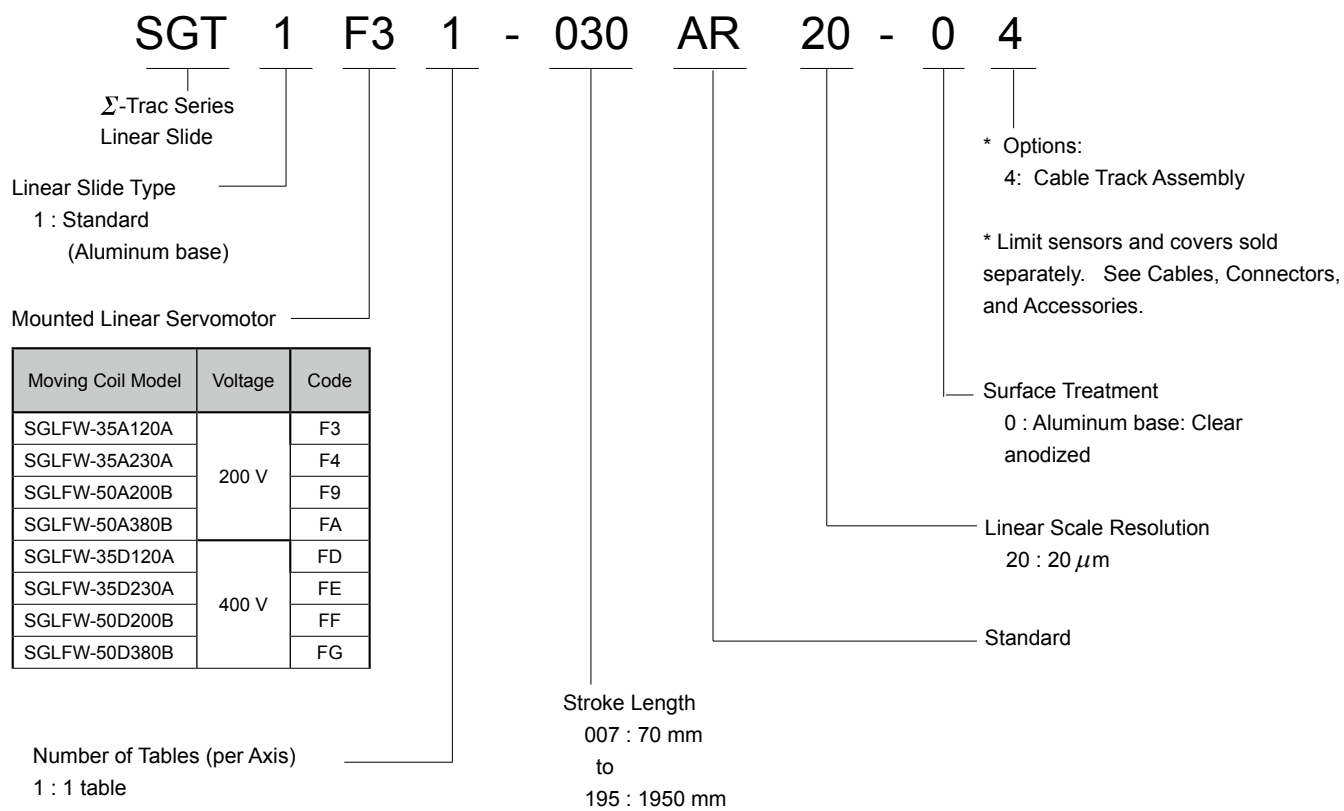

## Features

- Factory assembled, fully integrated linear motor driven slide reduces machine design complexity and commissioning time.
- Automatic motor recognition by Yaskawa amplifiers eliminates need for user to input motor coil parameters.
- Long strokes and high-speed, high accuracy positioning.
- Large integrated cable carrier allows space for peripheral cables and hoses.
- Covers and accessories available as accessories (up to 1 m stroke).
- See [www.yaskawa.com](http://www.yaskawa.com) for "Quick Ship" program details.

## Application Examples

- Pick and Place
- Precision Dispensing
- Vision Inspection
- Laser Cutting/Machining.
- Engraving
- Flat Panel Display Manufacture (LCD Substrate Handling)
- Industrial Laser and Ink Jet Printing
- Electronic Component Assembly
- Insertion Machines (Packaging)

## Model Classification

### ● Force

SERVOPACK Model SGD-			Σ-Trac Series Linear Slides							
Single-phase 100 VAC	Three-phase 200 VAC	Three-phase 400 VAC	Model	Force	200 N	400 N	600 N	800 N	1000 N	1200 N
2R1F	1R6A	–	SGT1F31-□□□							
–	–	1R9D	SGT1FD1-□□□						Rated force	Peak force
–	3R8A	–	SGT1F41-□□□							
–	–	1R9D	SGT1FE1-□□□							
–	5R5A	–	SGT1F91-□□□							
–	–	3R5D	SGT1FF1-□□□							
–	120A	–	SGT1FA1-□□□							
–	–	5R4D	SGT1FG1-□□□							

### ● Stroke Length

Model	Stroke Length	500 mm	1000 mm	1500 mm	2000 mm
SGT1F31-□□□ SGT1FD1-□□□	80 mm				1950 mm
SGT1F41-□□□ SGT1FE1-□□□	180 mm				1830 mm
SGT1F91-□□□ SGT1FF1-□□□	70 mm				1830 mm
SGT1FA1-□□□ SGT1FG1-□□□	170 mm				1650 mm

# SGT1F31, SGT1F41, SGT1FD1, and SGT1FE1 Linear Slides

## ● Ratings and Specifications

Time Rating: Continuous  
 Insulation Resistance: 500 VDC, 10 MΩ min.  
 Ambient Temperature: 0 to 40°C  
 Excitation: Permanent magnet

Withstand Voltage: 1500 VAC for one minute  
 Enclosure: Self-cooled  
 Ambient Humidity: 20% to 80% (no condensation)  
 Winding Insulation: Class A

Linear Slide Model <sup>*1</sup>		200 V Models		400 V Models	
		SGT1F31-□□□ AR20-04	SGT1F41-□□□ AR20-04	SGT1FD1-□□□ AR20-04	SGT1FE1-□□□ AR20-04
Mounted Linear Servomotor Model	SGLFW-	35A120AP	35A230AP	35D120AP	35D230AP
Applicable SERVOPACK Model	SGDV-	2R1F, 1R6A	3R8A	1R9D	1R9D
Mounted Serial Converter Unit Model	JZDP-	D008-019	D008-020	D008-211	D008-212
Rated Force	N	80	160	80	160
Peak Force	N	220	440	220	440
Force Constant	N / A <sub>rms</sub>	62.4	62.4	136	136
Motor Constant	N / √W	14.4	20.4	14.2	20.1
Maximum Payload <sup>*2, *3</sup>	kg	30	70	30	70
Movable Member Mass	kg	4.3	6.6	4.3	6.6
Total Mass	kg	See Table 1	See Table 2	See Table 1	See Table 2
Effective Stroke	mm	on the next page.	on the next page.	on the next page.	on the next page.
Resolution	μm	0.078 (20 μm / 256)		0.078 (20 μm / 256)	
Repeatability <sup>*4</sup>	μm	±1.0	±1.0	±1.0	±1.0
Absolute Accuracy	μm	Consult factory		Consult factory	
Straightness and Flatness	μm	Consult factory		Consult factory	

\*1: Squares (□□□) are used to indicate the stroke length code shown in Tables 1 and 2.

\*2: Values obtained when the acceleration is 4.9 m/s<sup>2</sup>.

\*3: Contact your Yaskawa representative if the expected payload exceeds the value indicated in the table.

\*4: Values obtained when the ambient temperature is constant.

## ● Performance Curves

### ● Force - Speed

**A** : Continuous Duty Zone  
**B** : Intermittent Duty Zone (Note)

(1) SGT1F31,  
SGT1FD1

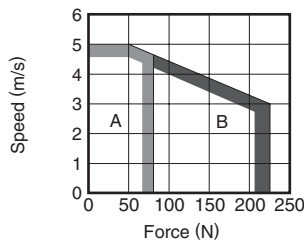

(2) SGT1F41,  
SGT1FE1

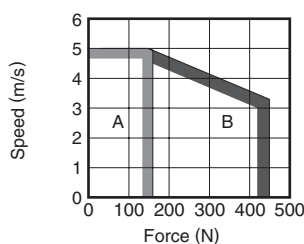

Note: When the effective force during intermittent duty is within the rated force, the servomotor can be used within the intermittent duty zone.

### ● Effective Force - Ambient Temperature ● Load Mass - Acceleration

When the sensor temperature is 50°C or less

Average speed (m/s) : 0 — 1 — 2 —

Note: Average speed = Total movement distance (m) / cycle time (s)

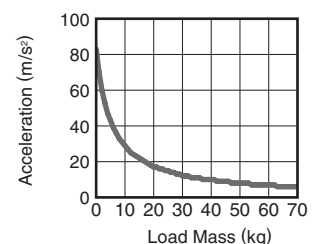
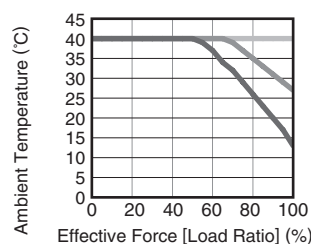
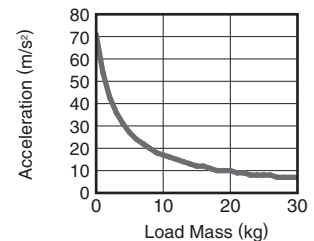
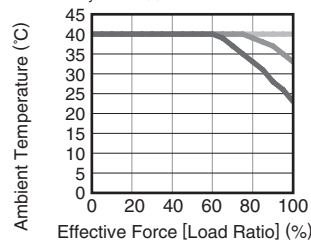

SGT1F31, SGT1F41, SGT1FD1, and SGT1FE1 Linear Slides Units: mm

● External Dimensions

(1) SGT1F31, SGT1FD1

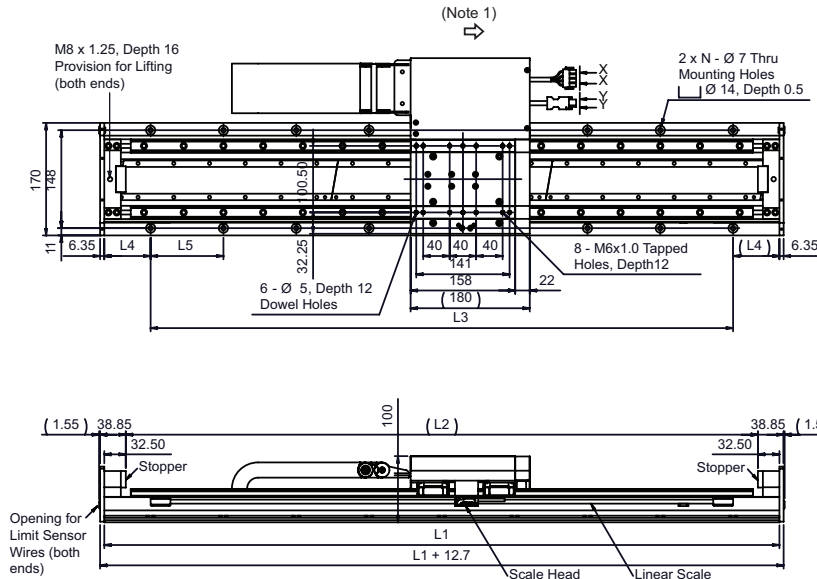

Table 1

Stroke		L1	L2	L3	L4	L5	N	Total Mass
Code	Length	mm	mm	mm	mm	mm		kg
008	80	360	295	270	45	90	4	10.4
030	300	580	515	440			5	14.4
041	410	690	625	550			6	16.3
052	520	800	735	660			7	18.2
063	630	910	845	770			8	20.0
074	740	1020	955	880			9	21.9
085	850	1130	1065	990			10	23.9
096	960	1240	1175	1100			11	26.0
107	1070	1350	1285	1210	70	110	12	27.8
118	1180	1460	1395	1320			13	29.8
129	1290	1570	1505	1430			14	31.6
140	1400	1680	1615	1540			15	33.5
151	1510	1790	1725	1650			16	35.6
162	1620	1900	1835	1760			17	37.5
173	1730	2010	1945	1870			18	39.4
184	1840	2120	2055	1980			19	41.3
195	1950	2230	2165	2090			20	43.2

(2) SGT1F41, SGT1FE1

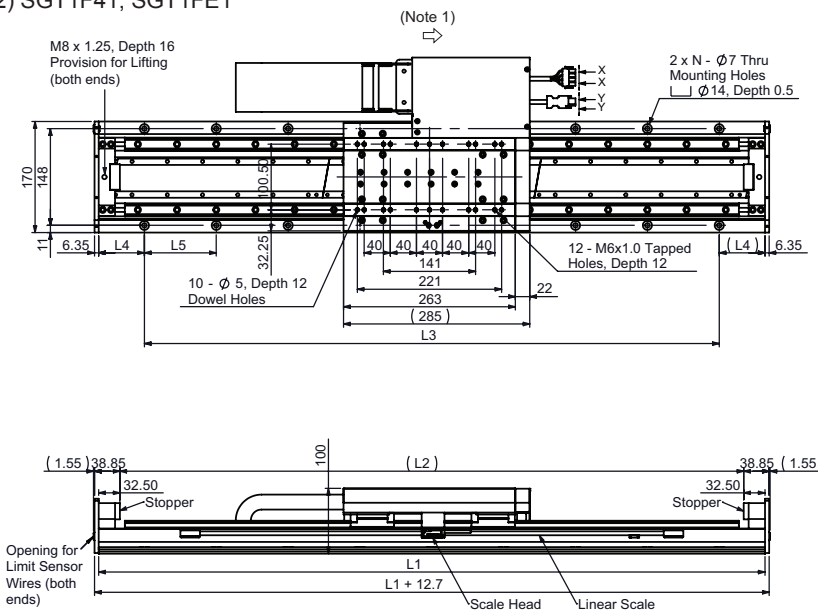

Table 2

Stroke		L1	L2	L3	L4	L5	N	Total Mass
Code	Length	mm	mm	mm	mm	mm		kg
018	180	580	515	440			5	16.5
029	290	690	625	550			6	18.5
040	400	800	735	660			7	20.4
051	510	910	845	770			8	22.2
062	620	1020	955	880			9	24.2
073	730	1130	1065	990			10	26.1
084	840	1240	1175	1100			11	28.6
095	950	1350	1285	1210	70	110	12	30.1
106	1060	1460	1395	1320			13	32.0
117	1170	1570	1505	1430			14	33.8
128	1280	1680	1615	1540			15	35.8
139	1390	1790	1725	1650			16	37.7
150	1500	1900	1835	1760			17	39.8
161	1610	2010	1945	1870			18	41.6
172	1720	2120	2055	1980			19	43.6
183	1830	2230	2165	2090			20	44.3

- Notes: 1 The moving coil moves in the direction indicated by the arrow when current flows in the order of phase U, V, and W.  
2 When installing the linear slide, the surface should be flat to the equivalent of a maximum discrepancy of 0.02/200 mm (reference value).

• Connector Specifications for the Σ-Trac Series Linear Slides (All Models)

View X-X

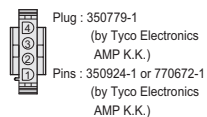

Pin No.	Signal
1	Phase-U output
2	Phase-V output
3	Phase-W output
4	FG

View Y-Y

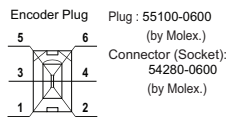

For Encoder Connection

Pin	Signal	Wire Color
1	PG 5V	Red
2	PG 0V	Black
3	-	-
4	-	-
5	Data +	Light Blue
6	Data -	White/Light Blue

# SGT1F91, SGT1FA1, SGT1FF1, and SGT1FG1 Linear Slides

## ● Ratings and Specifications

Time Rating: Continuous  
 Insulation Resistance: 500 VDC, 10 MΩ min.  
 Ambient Temperature: 0 to 40°C  
 Excitation: Permanent magnet

Withstand Voltage: 1500 VAC for one minute  
 Enclosure: Self-cooled  
 Ambient Humidity: 20% to 80% (no condensation)  
 Winding Insulation: Class A

Linear Slide Model <sup>1</sup>		200 V Models		400 V Models	
		SGT1F91-□□□ AR20-04	SGT1FA1-□□□ AR20-04	SGT1FF1-□□□ AR20-04	SGT1FG1-□□□ AR20-04
Mounted Linear Servomotor Model	SGLFW-	50A200BP	50A380BP	50D200BP	50D380BP
Applicable SERVOPACK Model	SGDV-	5R5A	120A	3R5D	5R4D
Applicable Serial Converter Unit Model	JZDP-	D008-181	D008-182	D008-189	D008-190
Rated Force	N	280	560	280	560
Peak Force	N	600	1200	600	1200
Force Constant	N / A <sub>rms</sub>	60.2	60.2	134.7	134.7
Motor Constant	N / √W	34.3	48.5	34.4	47.2
Maximum Payload <sup>2, 3</sup>	kg	100	215	100	215
Movable Member Mass	kg	8.5	14.5	8.5	14.5
Total Mass	kg	See Table 1	See Table 2	See Table 1	See Table 2
Effective Stroke	mm	on the next page.	on the next page.	on the next page.	on the next page.
Resolution	μm	0.078 (20 μm / 256)		0.078 (20 μm / 256)	
Repeatability <sup>4</sup>	μm	±1.0		±1.0	
Absolute Accuracy	μm	Consult factory		Consult factory	
Straightness and Flatness	μm	Consult factory		Consult factory	

\*1: Squares (□□□) are used to indicate the stroke length code shown in Tables 1.  
 \*2: Values obtained when the acceleration is 4.9 m/s<sup>2</sup>.  
 \*3: Contact your Yaskawa representative if the expected payload exceeds the value indicated in the table.  
 \*4: Values obtained when the ambient temperature is constant.

## ● Performance Curves

### ● Force - Speed

**A** : Continuous Duty Zone  
**B** : Intermittent Duty Zone (Note)

(1) SGT1F91,  
SGT1FF1

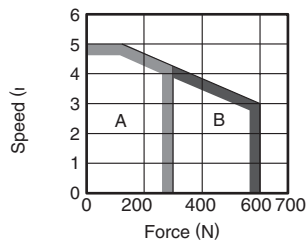

(2) SGT1FA1,  
SGT1FG1

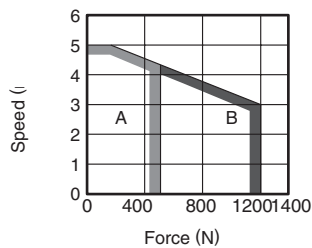

Note: When the effective force during intermittent duty is within the rated force, the servomotor can be used within the intermittent duty zone.

### ● Effective Force - Ambient Temperature ● Load Mass - Acceleration

When the sensor temperature is 50°C or less  
 Average speed (m/s) : 0 — 1 — 2 —  
 Note: Average speed = Total movement distance (m) / cycle time (s)

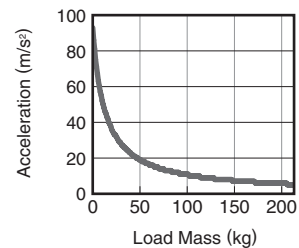
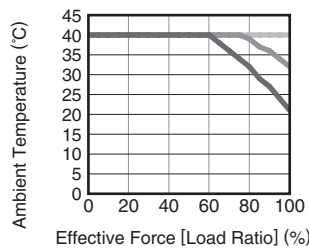
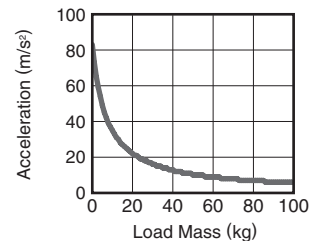
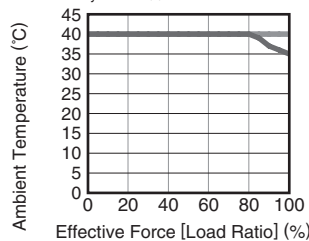

SGT1F91, SGT1FA1, SGT1FF1, and SGT1FG1 Linear Slides Units: mm

● External Dimensions

(1) SGT1F91, SGT1FF1

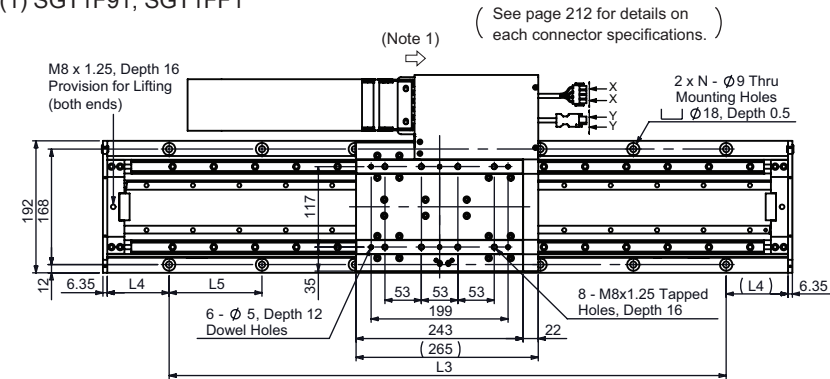

(Note 1) ( See page 212 for details on each connector specifications. )

Table 1

Stroke Code	Length	L1 mm	L2 mm	L3 mm	L4 mm	L5 mm	N	Total Mass kg
007	70	440	375	300	70	100	4	17.3
035	350	720	655	540	90	135	5	22.8
048	480	850	785	675	87.5		6	25.6
062	620	990	925	810	90		7	28.4
075	750	1120	1055	945	87.5		8	31.0
089	890	1260	1195	1080	90		9	33.8
102	1020	1390	1325	1215	87.5		10	36.6
116	1160	1530	1465	1350	90		11	39.3
129	1290	1660	1595	1485	87.5		12	41.9
143	1430	1800	1735	1620	90		13	44.7
156	1560	1930	1865	1755	87.5		14	47.5
170	1700	2070	2005	1890	90		15	50.2
183	1830	2200	2135	2025	87.5		16	53.0

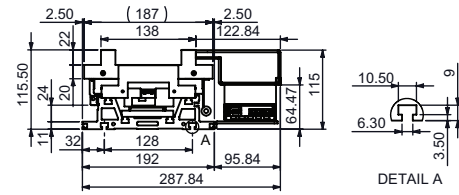
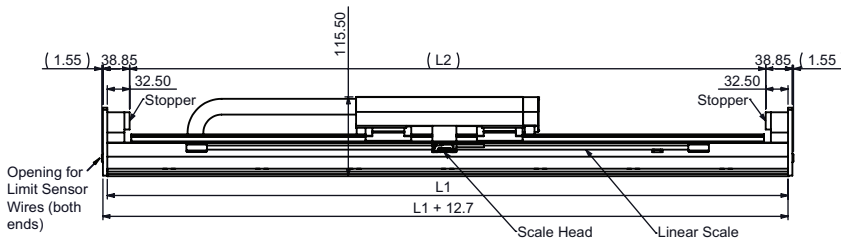

Note: Endplate removed in this view

(2) SGT1FA1, SGT1FG1

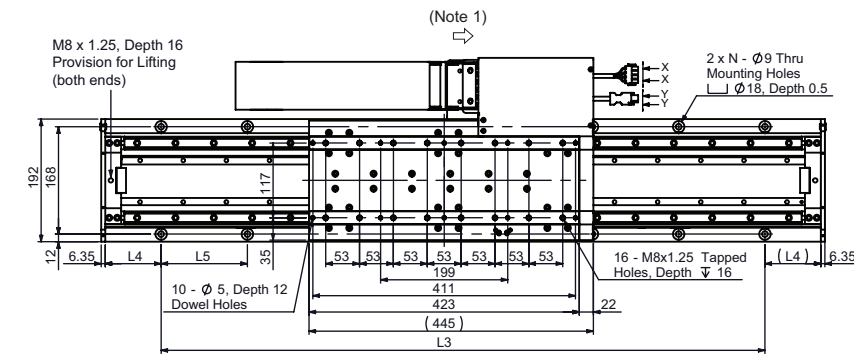

(Note 1)

Table 2

Stroke Code	Length	L1 mm	L2 mm	L3 mm	L4 mm	L5 mm	N	Total Mass kg
017	170	720	655	540	90	135	5	28.7
030	300	850	785	675	87.5		6	31.6
044	440	990	925	810	90		7	34.4
057	570	1120	1055	945	87.5		8	37.0
071	710	1260	1195	1080	90		9	39.7
084	840	1390	1325	1215	87.5		10	42.6
098	980	1530	1465	1350	90		11	45.3
111	1110	1660	1595	1485	87.5		12	47.9
125	1250	1800	1735	1620	90		13	50.6
138	1380	1930	1865	1755	87.5		14	53.4
152	1520	2070	2005	1890	90		15	56.2
165	1650	2200	2135	2025	87.5		16	58.9

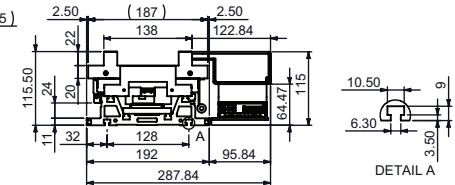
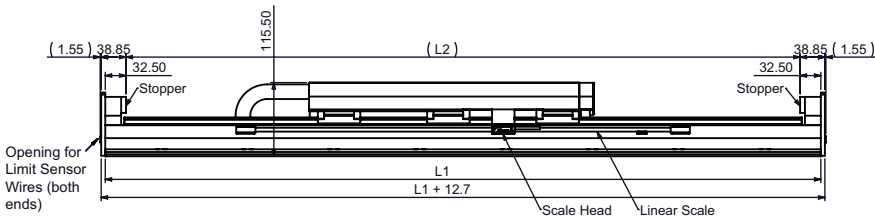

Note: Endplate removed in this view

Notes: 1 The moving coil moves in the direction indicated by the arrow when current flows in the order of phase U, V, and W.  
2 When installing the linear Slide, the surface should be flat to the equivalent of a maximum discrepancy of 0.02/200 mm (reference value).



# Selecting Cables, Connectors, and Accessories

## ● Connection diagrams

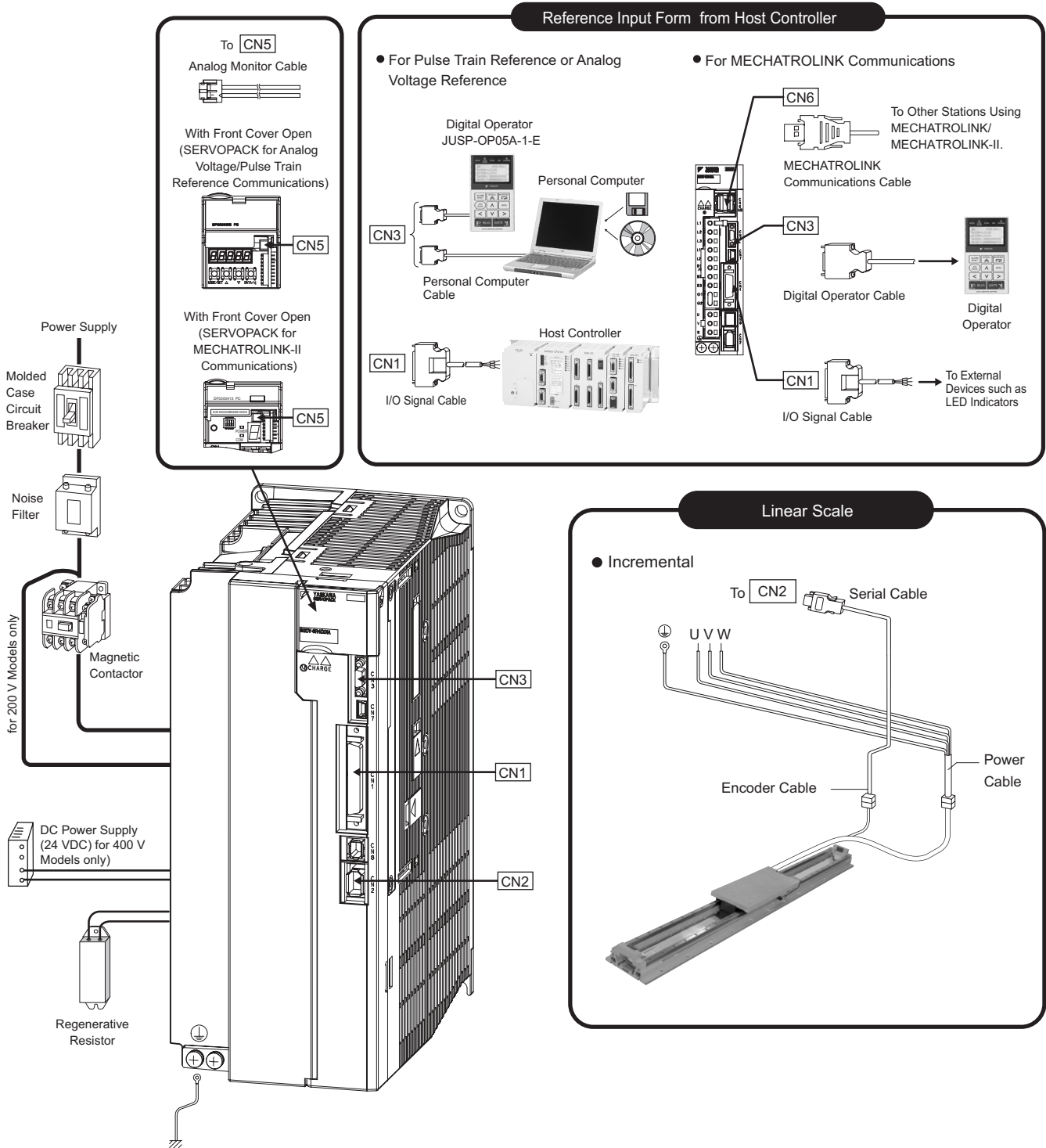

## Selecting Cables, Connectors, and Accessories

### ● Applicable Cables and Connectors

Motor Type	Linear Scale Type	Servo Drive			Motor Cable	Linear Scale Connection Cables	Pulse-train or Analog Voltage Reference			
		Σ-Trac Series Model	SERVOPACK Model SGD-			SERVOPACK ↔ Motor	[CN2] ↔ Encoder Cable	I/O Signal Connector [CN1]		
			Single-phase 100 V	Three-phase 200 V	Three-phase 400 V	Power Cable (Flexible Type)	Serial Cable (Flexible Type)	Connector Terminal Block Converter Unit	Cable with Loose Wires at One End	Connector Kit (CN1)
Moving Coil (MC)	Incremental	SGT1F31-□□□ AR20-04	2R1F,	-	-	JZSP-CLN11-□□	JZSP-CMP00-□□ (A)  The numbers in the boxes(□□) indicate the cable length. 03 = 3 m 05 = 5 m 10 = 10 m 15 = 15 m 20 = 20 m	JZSP-TA50PG-E  (with a 0.5 m cable)	JZSP-CS101-□-E  The number in the box (□) indicates the cable length. 1 = 1 m 2 = 2 m 3 = 3 m	JZSP-CS19-1-E
		SGT1FD1-□□□ AR20-04	-	1R6A	-					
		SGT1F41-□□□ AR20-04	-	3R8A	-	JZSP-CLN11-□□				
		SGT1FE1-□□□ AR20-04	-	-	1R9D	JZSP-CLN21-□□				
		SGT1F91-□□□ AR20-04	-	5R5A	-	JZSP-CLN21-□□				
		SGT1FF1-□□□ AR20-04	-	-	3R5D	JZSP-CLN21-□□				
		SGT1FA1-□□□ AR20-04	-	120A	-	JZSP-CLN21-□□				
		SGT1FG1-□□□ AR20-04	-	-	5R4D	JZSP-CLN21-□□				

Motor Type	Linear Scale Type	Servo Drive			MECHATROLINK Communications			Cables for Setting Devices/Monitors		
		Σ-Trac Series Model	SERVOPACK Model SGD-			I/O Signal Connector [CN1]		[CN3] ↔ Setting Devices	[CN5]	
			Single-phase 100 V	Three-phase 200 V	Three-phase 400 V	Connector Terminal Block Converter Cable	Connector Kit (CN1)	MECHATROLINK Communications Connector [CN6A] or [CN6B]	Personal Computer Cable	Analog Monitor Cable
Moving Coil (MC)	Incremental	SGT1F31-□□□ AR20-04	2R1F,	-	-	JZSP-TA26P-□-E  □ → None = 0.5 m 1 = 1 m 2 = 2 m	JZSP-CS19-2-E (DE9411354)	MECHATROLINK communications cable: JEPMC-W6002-□□-E The numbers in the boxes(□□) indicate the cable length. A5 = 0.5 m 20 = 20 m 01 = 1 m 30 = 30 m 03 = 3 m 40 = 40 m 05 = 5 m 50 = 50 m 10 = 10 m  MECHATROLINK terminator: JEPMC-W6022-E	JZDP-CMS02-E (2 m)	JZSP-CA01-E (1 m)
		SGT1FD1-□□□ AR20-04	-	1R6A	-					
		SGT1F41-□□□ AR20-04	-	3R8A	-					
		SGT1FE1-□□□ AR20-04	-	-	1R9D					
		SGT1F91-□□□ AR20-04	-	5R5A	-					
		SGT1FF1-□□□ AR20-04	-	-	3R5D					
		SGT1FA1-□□□ AR20-04	-	120A	-					
		SGT1FG1-□□□ AR20-04	-	-	5R4D					

### ● Applicable Accessories

Cover Kits: SGTA-CVR 3 - 030

Stroke Code for Motor Selected

Motor Code	
3	Covers for SGT1F31, SGT1FD1
4	Covers for SGT1F41, SGT1FE1
9	Covers for SGT1F91, SGT1FF1
A	Covers for SGT1FA1, SGT1FG1

Stroke Codes		Cover Length (mm)
SGT1F31 SGT1FD1	SGT1F41 SGT1FE1	
008	-	372.7
030	018	592.7
041	029	702.7
052	040	812.7
063	051	922.7
074	062	1032.7
085	073	1142.7
096	084	1252.7
107	095	1362.7

Stroke Codes		Cover Length (mm)
SGT1F91 SGT1FF1	SGT1FA1 SGT1FG1	
007	-	452.7
035	017	732.7
048	030	862.7
062	044	1002.7
075	057	1132.7
089	071	1272.7
102	084	1402.7

Note: Cover kit includes 1 top cover, 2 side covers, and all mounting hardware.

Limit Sensor Kits: SGTA-LSK□□□

Code	Description
PNO	PNP Normally Open
NNO	NPN Normally Open
NNC	NPN Normally Closed

Kit includes 1 sensor plus mounting screw.

# Analog Voltage/Pulse Train Reference Type SERVOPACKs

## SGDV-□□□□01

(For Rotary Servomotors)

## SGDV-□□□□05

(For Linear Servomotors)



### Model Designations

SGDV - R70 A 01 B 002000

$\Sigma$ -V Series  
SGDV SERVOPACK

Current

Voltage

Options

Code	Specifications
002000	Base-mounted, varnish(standard)
008000	Single-phase, 200VAC Input (model: SGD-120A01A008000)

Design Revision

Code	Specification
B	Standard

Interface

Code	Specifications
F	100 VAC
A	200 VAC
D	400 VAC

Code	Specifications
01	Analog voltage/pulse train reference type (for rotary servomotors)
05	Analog voltage/pulse train reference type (for linear servomotors)

Code	100 V (Single Phase)		Code	200 V (Three Phase)		Code	400 V (Three Phase)	
	Applicable Servomotor Max. Capacity kW			Applicable Servomotor Max. Capacity kW			Applicable Servomotor Max. Capacity kW	
R70	0.05		R70*	0.05		1R9	0.5	
R90	0.1		R90*	0.1		3R5	1.0	
2R1	0.2		1R6*	0.2		5R4	1.5	
2R8	0.4		2R8*	0.4		8R4	2.0	
			3R8	0.5		120	3.0	
			5R5*	0.75		170	5.0	
			7R6	1.0		210	6.0	
			120**	1.5		260	7.5	
			180	2.0		280	11	
			200	3.0		370	15	
			330	5.0				
			470	6.0				
			550	7.5				
			590	11				
			780	15				

NOTE: Shaded items are non-stock.

\* These amplifiers can be powered with single or three-phase.

\*\* SGD-120A□1A008000, a special version of the 1.5kW amplifier can be used for single-phase operation.

# Features

- Unprecedented ease-of-use through cutting-edge technology
  - New tuning-less function means no adjustment needed.
  - Impressive load regulation with strengthened vibration suppression function.
- Slashed setup time
  - Setup wizard function and wiring conformation function of engineering tool SigmaWin+ allows easy setup just by watching the monitor.
- High response characteristics at 1 kHz min.
  - New advanced autotuning.
  - Reduced positioning time through model following control, and smooth machine control enabled by vibration suppression function.

## Ratings

### Single-phase 100 V

SERVOPACK Model	SGDV-□□□□	R70F	R90F	2R1F	2R8F
Applicable Servomotor Max. Capacity	kW	0.05	0.1	0.2	0.4
Continuous Output Current	$A_{rms}$	0.66	0.91	2.1	2.8
Max. Output Current	$A_{rms}$	2.1	2.9	6.5	9.3
Main Circuit (Single Phase)		100 to 115 VAC+10% to -15% 50/60 Hz			
Control Circuit (Single Phase)		100 to 115 VAC+10% to -15% 50/60 Hz			

### Single-phase 200 V

SERVOPACK Model	SGDV-□□□□	R70A	R90A	1R6A	2R8A	5R5A	120
Applicable Servomotor Max. Capacity	kW	0.05	0.1	0.2	0.4	0.75	1.5
Continuous Output Current	$A_{rms}$	0.66	0.91	1.6	2.8	5.5	11.6
Max. Output Current	$A_{rms}$	2.1	2.9	6.5	9.3	16.9	28
Main Circuit (Single Phase)		220 to 230 VAC +10% to -15% 50/60 Hz					
Control Circuit (Single Phase)		220 to 230 VAC +10% to -15% 50/60 Hz					

### Three-phase 200 V

SERVOPACK Model	SGDV-□□□□	R70A	R90A	1R6A	2R8A	3R8A	5R5A	7R6A	120A	180A	200A	330A	470A	550A	590A	780A
Applicable Servomotor Max. Capacity	kW	0.05	0.1	0.2	0.4	0.5	0.75	1.0	1.5	2.0	3.0	5.0	6	7.5	11	15
Continuous Output Current	$A_{rms}$	0.66	0.91	1.6	2.8	3.8	5.5	7.6	11.6	18.5	19.6	32.9	46.9	54.7	58.6	78
Max. Output Current	$A_{rms}$	2.1	2.9	6.5	9.3	11	16.9	17	28	42	56	84	110	130	140	170
Main Circuit		Three-phase 200 to 230 VAC+10% to -15% 50/60 Hz														
Control Circuit		Single-phase 200 to 230 VAC+10% to -15% 50/60 Hz														

### Three-phase 400 V

SERVOPACK Model	SGDV-□□□□	1R9D	3R5D	5R4D	8R4D	120D	170D	210D	260D	280D	370D
Applicable Servomotor Max. Capacity	kW	0.5	1.0	1.5	2.0	3.0	5.0	6	7.5	11	15
Continuous Output Current	$A_{rms}$	1.9	3.5	5.4	8.4	11.9	16.5	20.8	25.4	28.1	37.2
Max. Output Current	$A_{rms}$	5.5	8.5	14	20	28	42	55	65	70	85
Main Circuit		Three-phase 380 to 480 VAC+10% to -15% 50/60 Hz									
Control Circuit		24 VDC ±15%									

### ●SERVOPACK Overload Characteristics

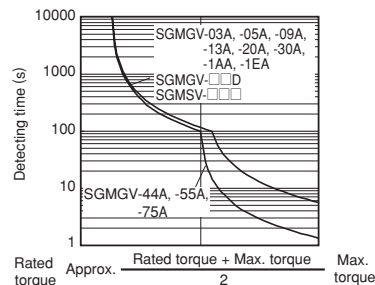
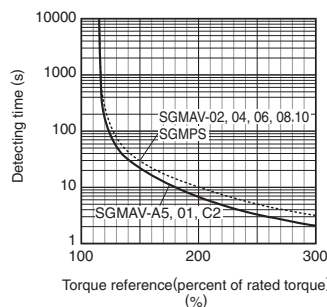
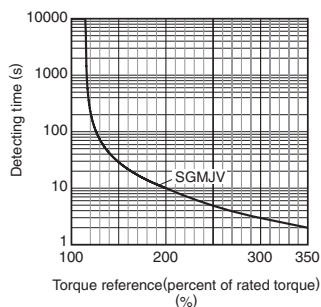

Note: Overload characteristics shown above do not guarantee continuous duty of 100% or more output. Use a servomotor with effective torque within the continuous duty zone of Torque-Motor Speed Characteristics.

# Specifications

Items		Specifications	
Input Power Supply	Main Circuit	100 V	Single-phase 100 to 115 VAC + 10% to - 15% 50/60 Hz
		200 V	Three-phase 200 to 230 VAC + 10% to - 15% 50/60 Hz
		400 V	Three-phase 380 to 480 VAC + 10% to - 15% 50/60 Hz
	Control Circuit	100 V	Single-phase 100 to 115 VAC + 10% to - 15% 50/60 Hz
		200 V	Single-phase 200 to 230 VAC + 10% to - 15% 50/60 Hz
400 V		24 VDC ± 15%	
Control Method		For 100 V, for 200 V, for 400 V, single-phase or three-phase full-wave rectification IGBT PWM control, sine-wave driven	
Feedback	Rotary Servomotors	Serial encoder: 13-bit (incremental encoder) : 17-bit (incremental/absolute encoder) : 20-bit (incremental/absolute encoder)	
	Linear Servomotors	Serial converter or serial data	
Operating Conditions	Surrounding/Storage Temperature	Surrounding temperature: 0 to +55°C, storage temperature: -20 to +85°C	
	Ambient/Storage Humidity	90%RH or less (no condensation)	
	Vibration/Shock Resistance	Vibration resistance: 4.9 m/s <sup>2</sup> , Shock resistance: 19.6 m/s <sup>2</sup>	
	Protection class/Pollution degree	Protection class: IP 1X, pollution degree: 2 Do not use SERVOPACKs in the following locations: · Locations subject to corrosive or flammable gasses · Locations subject to exposure to water, oil, or chemicals · Locations subject to dust, including iron dust, and salts	
	Others	Do not use SERVOPACKs in the following locations: · Locations subject to static electricity noise, strong electromagnetic/magnetic fields, radioactivity	
Elevation		1000 m or less	
Compliant Standards		UL 508C EN50178, EN55011 class A group 1, EN61800-3, EN61800-5-1	
Configuration		Base-mounted (Rack-mounting available as an option for some models. 6 kW or more models are duct-ventilated.)	
Performance	Speed Control Range	1:5000 (The lowest speed of the speed control range is the speed at which the servomotor will not stop with a rated torque load.)	
	Speed Regulation*	Load Regulation	0% to 100% load: ±0.01% max. (at rated speed)
		Voltage Regulation	Rated voltage: ±10% : 0% (at rated speed)
		Temperature Regulation	25 ± 25°C : ±0.1% max. (at rated speed)
	Torque Control Tolerance (Repeatability)	±1%	
Soft Start Time Setting	0 to 10 s (can be set individually for acceleration and deceleration.)		
I/O Signals	Encoder Output Pulses	Phase A, phase B, phase C: line driver output The number of dividing pulse: Any setting ratio is available.	
Communications	RS-422A Communications	Interface	Digital operator, RS-422A port of personal computers etc.
		1:N communications	RS-422A port: N= 15 max. available
		Axis address setting	Set by parameters
	USB Communications	Function	Status display, parameter settings, adjustment functions, utility functions, parameter copy functions
		Interface	Personal computers (application: engineering tool SigmaWin+)
USB Communications	1:N communications	Compliant with USB1.1 standard	
	Function	Status display, parameter settings, adjustment functions, utility functions, parameter copy functions, waveform trace	
Display	Power Charge	CHARGE for main circuit power supply input confirmation One LED (orange)	
Analog Monitor		Analog monitor connector built in for monitoring speed, torque and other reference signals. Number of points: 2	
Protective Functions		Overcurrent, Overvoltage, low voltage, overload, regeneration error	
Utility Functions		Alarm history, JOG operation, origin search, etc.	
Regenerative Processing		100 VAC model: External regenerative resistor (optional) 200 VAC SGDVR70A, -R90A, -1R6A, -2R8A: External regenerative resistor (optional) 200 VAC SGDV-470A, -550A, -590A, -780A: External regenerative resistor unit (optional) 200 VAC models other than shown above: Built-in regenerative resistor 400 VAC SGDV-210D, -260D, -280D, -370D: External regenerative resistor unit (optional) 400 VAC models other than shown above: Built-in regenerative resistor	
Safety Functions	Input	/HWBB1, /HWBB2: Hard wire base block signal	
	Output	EDM1: Status monitor (fixed output) of built-in safety circuit	
	Compliant Standards	EN954 category 3 Stop category 0, IEC61508 SIL 2	
Option Card Function	Feedback	Serial encoder communications input for fully-closed loop control	

\*: Speed regulation is defined as follows:

$$\text{Speed regulation} = \frac{\text{No-load motor speed} - \text{Total load motor speed}}{\text{Rated motor speed}} \times 100\%$$

The motor speed may change due to voltage variations or temperature variation. The ratio of speed changes to the rated speed represent speed regulation due to voltage and temperature variations.

## Specifications

## ● Rotary Servomotors

Items		Specifications		
I/O Signal	Encoder Output Pulses		Phase A, phase B, phase C: line driver output The number of dividing pulse: Any setting ratio is available.	
	Sequence Input	Fixed Input	SEN signal	
		Input Signals which can be allocated	Number of Channels	7 channels
			Functions	The signal allocation and positive/negative logic can be modified. Servo On (/S-ON), proportional control (/P-CON), alarm reset (/ALM-RST), forward run prohibited (P-OT), reverse run prohibited (/N-OT), forward torque limit (/P-CL), reverse torque limit(/N-CL), internal set speed selection (/SPD-D, /SPD-A, /SPD-B), control selection (/C-SEL), zero clamping (/ZCLAMP), reference pulse inhibit (/INHIBIT), gain selection (/G-SEL)
	Sequence Output	Fixed Output	Servo alarm (ALM), alarm code (ALO1, ALO2, ALO3) outputs	
		Output Signals which can be allocated	Number of Channels	3 channels
	Functions		The signal allocation and positive/negative logic can be modified. Positioning completion (/COIN), speed coincidence detection (/V-CMP), servomotor rotation detection (/TGON), servo ready (/S-RDY), torque limit detection (/CLT), speed limit detection (/VLT), brake interlock (/BK), warning (/WRAN), near (/NEAR)	
Panel Operator		Display	7-segment 5-digit LED (Red)	
		Switch	Push switch: 4 channels	
Torque Control	Analog Input	Reference Voltage	$\pm 3$ VDC (Variable setting range: $\pm 1$ to 10 VDC) at rated torque, max. input voltage: $\pm 12$ V	
		Input Impedance	About 14 k $\Omega$ min.	
		Circuit Time Constant	16 $\mu$ s	
Speed Control	Analog Input	Reference Voltage	$\pm 6$ VDC (variable setting range: $\pm 2$ to 10 VDC) at rated speed, max. input voltage: $\pm 12$ V	
		Input Impedance	About 14 k $\Omega$ min.	
		Circuit Time Constant	30 $\mu$ s	
	Internal Set Speed Control	Rotation Direction Selection	Switches the direction by /P-CON (/SPD-D)	
		Speed Selection	Speed 1 to 3 selection	
Function	Soft Start Setting	0 to 10 s (can be set individually for acceleration and deceleration.)		
Position Control	Reference Pulse	Type	Sign + pulse train, 90° phase difference 2-phase pulse (phase A + phase B), or CCW + CW pulse train	
		Form	Non-insulated line driver (+5 V level), open collector	
		Max. Input Pulse Frequency*	Sign+ Pulse train : 4 Mpps CW+ CCW pulse train : 4 Mpps 90° phase difference 2-phase pulse × 1 multiplier : 1 Mpps (before multiplier) × 2 multiplier : 1 Mpps (before multiplier) × 4 multiplier : 1 Mpps (before multiplier) Open collector : 200 kpps	
	Clear Signal	Function	Clears error pulse by external signals.	
		Form	Applicable to line driver, open collector	

\*: If the maximum reference frequency exceeds 1 Mpps, use a shielded cable for I/O signals and ground both ends of the shield. Connect the shield at the SERVOPACK to the connector shell.

# Specifications

## ● Linear Servomotors

Items		Specifications		
I/O Signal	Encoder Output Pulses	Phase A, phase B, phase C: line driver output The number of dividing pulse: Any setting ratio is available.		
	Sequence Input	Input Signals which can be allocated	Number of Channels	7 channels
			Functions	The signal allocation and positive/negative logic can be modified. Servo ON (/S-ON), proportional control (/P-CON), alarm reset (/ALM-RST), forward run prohibited (P-OT), reverse run prohibited (N-OT), forward external force limit (/P-CL), reverse external force limit (/N-CL), internal set speed selection (/SPD-D, /SPD-A, /SPD-B), control selection (/C-SEL), zero clamping (/ZCLAMP), reference pulse inhibit (/INHIBIT), gain selection (/G-SEL), polarity detection (P-DET)
	Sequence Output	Fixed Output	Servo alarm (ALM), alarm code (ALO1, ALO2, ALO3) outputs	
		Output Signals which can be allocated	Number of Channels	3 channels
	Functions		The signal allocation and positive / negative logic can be modified. Positioning completion (/COIN), speed coincidence detection (/V/CMP), servomotor movement detection (/TGON), servo ready (/S-RDY), force limit detection (/CLT), speed limit detection (/VLT), brake interlock (/BK), warning (/WARN), near (/NEAR)	
Panel Operator		Display	7-segment 5-digit LED (Red)	
		Switch	Push switch: 4 channels	
Force Control	Analog Input	Reference Voltage	±3 VDC (variable setting range: ±1 to 10 VDC), max. input voltage: ±12 V	
		Input Impedance	About 14 kΩ min.	
		Circuit Time Constant	16 μs	
Speed Control	Analog Input	Reference Voltage	±6 VDC (variable setting range: ±2 to 10 VDC) at rated speed, max. input voltage: ±12 V	
		Input Impedance	About 14 kΩ min.	
		Circuit Time Constant	30 μs	
	Internal Set Speed Control	Movement Direction Selection	/P-CON (/SPD-D) signal	
		Speed Selection	Speed 1 to 3 selection	
Function	Soft Start Setting	0 to 10 s (can be set individually for acceleration and deceleration.)		
Position Control	Reference Pulse	Type	Sign+ pulse train, 90° phase difference 2-phase pulse (phase A+phase B), or CCW+ CW pulse train	
		Form	Non-insulated line driver (+5 V level), open collector	
		Max. Input Pulse Frequency*	Sign+ Pulse train : 4 Mpps CW+ CCW pulse train : 4 Mpps 90° phase difference 2-phase pulse ×1 multiplier : 1 Mpps (before multiplier) ×2 multiplier : 1 Mpps (before multiplier) ×4 multiplier : 1 Mpps (before multiplier) Open collector : 200 kpps	
	Clear Signal	Function	Clears error pulse by external signals.	
		Form	Applicable to line driver, open collector	

\*: If the maximum reference frequency exceeds 1 Mpps, use a shielded cable for I/O signals and ground both ends of the shield. Connect the shield at the SERVOPACK to the connector shell.

## Power Supply Capacities and Power Losses

The following table shows SERVOPACK's power supply capacities and power losses at the rated output.

Main Circuit Power Supply	Applicable Servomotor Max. Capacity kW	SERVOPACK Model SGD V-	Power Supply Capacity kVA	Output Current A	Main Circuit Power Loss W	Regenerative Resistor Power Loss W	Control Circuit Power Loss W	Total Power Loss W
Signal-phase 100 V	0.05	R70F	0.2	0.66	5.4	—	17	22.4
	0.1	R90F	0.3	0.91	7.8			24.8
	0.2	2R1F	0.7	2.1	14.4			31.4
	0.4	2R8F	1.4	2.8	25.6			42.6
Single-phase 200 V	0.05	R70A	0.2	0.66	5.2	—	17	22.2
	0.1	R90A	0.3	0.91	7.4			24.4
	0.2	1R6A	0.7	1.6	13.7			30.7
	0.4	2R8A	1.2	2.8	24.9			41.9
	0.75	5R5A	1.9	5.5	52.7	8	77.7	
	1.5	120A	4	11.6	68.2	10	22	100.2
Three-phase 200 V	0.05	R70A	0.2	0.66	5.1	—	17	22.1
	0.1	R90A	0.3	0.91	7.3			24.3
	0.2	1R6A	0.6	1.6	13.5			30.5
	0.4	2R8A	1	2.8	24.0			41.0
	0.5	3R8A	1.4	3.8	20.1	8	45.1	
	0.75	5R5A	1.6	5.5	43.8		68.8	
	1.0	7R6A	2.3	7.6	53.6	10	78.6	
	1.5	120A	3.2	11.6	65.8		97.8	
	2.0	180A	4	18.5	111.9	16	22	149.9
	3.0	200A	5.9	19.6	113.8		161.4	
	5.0	330A	7.5	32.9	263.7	36	27	326.7
	6.0	470A	10.7	46.9	279.4	(180) <sup>1</sup>	33	312.4
	7.5	550A	14.6	54.7	357.8	(350) <sup>2</sup>		390.8
	11	590A	21.7	58.6	431.7	(350) <sup>2</sup>	48	479.7
15	780A	29.6	78	599.0	647.0			
Three-phase 400 V	0.5	1R9D	1.1	1.9	24.6	14	21	59.6
	1.0	3R5D	2.3	3.5	46.1			81.1
	1.5	5R4D	3.5	5.4	71.3			106.3
	2.0	8R4D	4.5	8.4	77.9	28	25	130.9
	3.0	120D	7.1	11.9	108.7			161.7
	5.0	170D	11.7	16.5	161.1	36	24	221.1
	6.0	210D	12.4	20.8	172.7	(180) <sup>3</sup>	27	199.7
	7.5	260D	14.4	25.7	218.6			245.6
	11	280D	21.9	28.1	294.6	(350) <sup>4</sup>	30	324.6
15	370D	30.6	37.2	403.8	433.8			

\*1: For the optional JUSP-RA04-E regenerative resistor unit.

\*2: For the optional JUSP-RA05-E regenerative resistor unit.

\*3: For the optional JUSP-RA18-E regenerative resistor unit.

\*4: For the optional JUSP-RA19-E regenerative resistor unit.

Notes: 1 SGD V-R70F, -R90F, -2R1F, -2R8F, -R70A, -R90A, -1R6A, and -2R8A SERVOPACKS do not have built-in regenerative resistors.

If the regenerative energy exceeds the specified value, connect an external regenerative resistor (optional).

2 SGD V-470A, -550A, -590A, -780A, -210D, -260D, -280D, -370D SERVOPACKS do not have built-in regenerative resistors.

Be sure to connect a regenerative resistor unit (optional) or an external regenerative resistor (optional).

3 Regenerative resistor power losses are allowable losses. Take the following action if this value is exceeded.

· Remove the lead or short bar that is short-circuiting the SERVOPACK main circuit terminal B2 and B3.

(SGD V-3R8A, -5R5A, -7R6A, -120A, -180A, -200A, -330A, or 400-V class SERVOPACKS.)

· Install an external regenerative resistor (optional).



## External Dimensions Units: mm

### ● Base-mounted SERVOPACKS

(1) Single-phase 100 VAC, Model: SGD V-R70F0□A, -R90F0□A, and -2R1F0□A

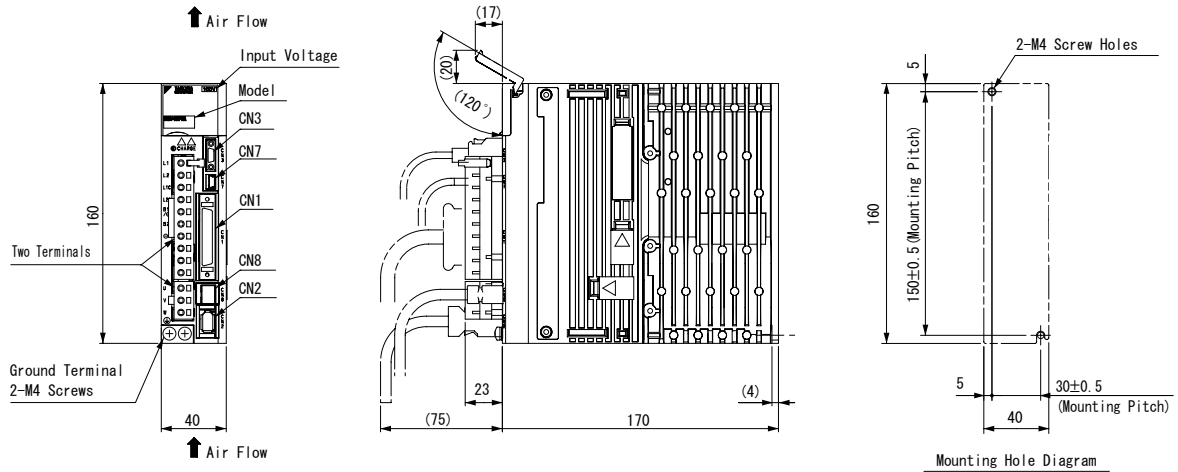

Approx. Mass: 1.1 kg

(2) Single-phase 100 VAC, Model: SGD V-2R8F0□A

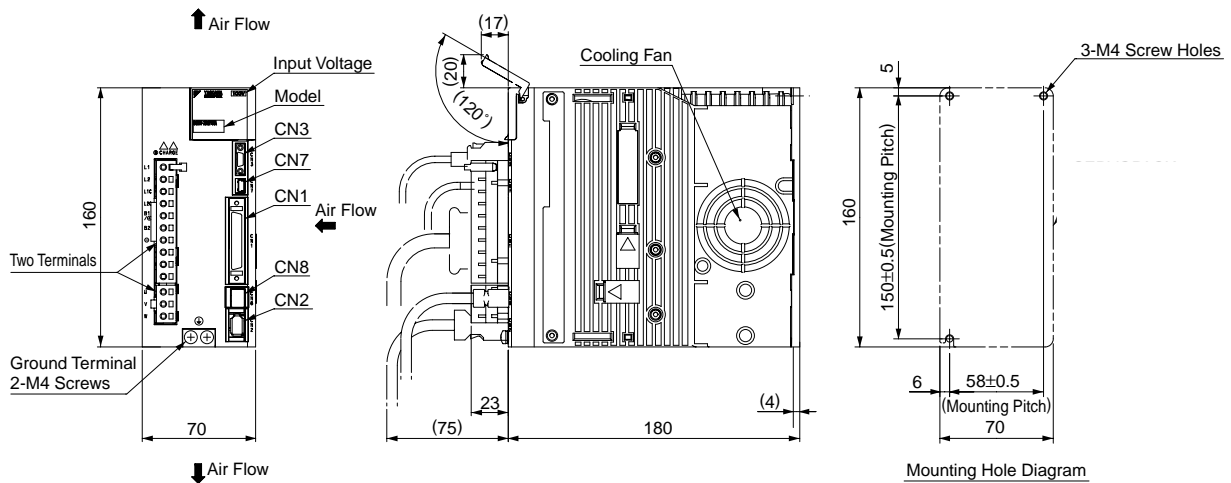

Approx. Mass: 1.5 kg

(3) Three-phase 200 VAC, Model: SGD V-R70A0□B, -R90A0□B, and -1R6A0□B

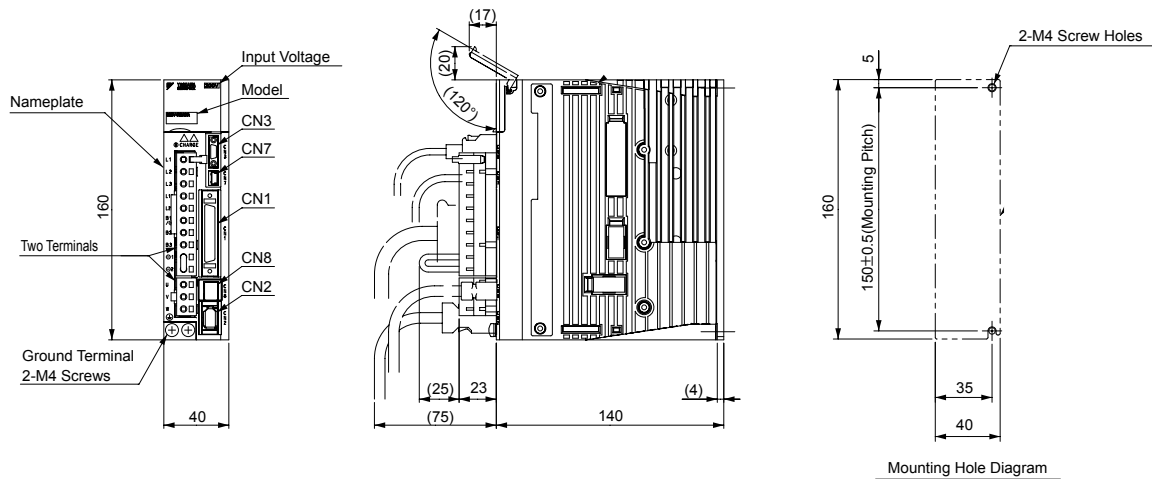

Approx. Mass: 0.9 kg

**External Dimensions** Units: mm

(4) Three-phase 200 VAC, Model: SGDV-2R8A0□B

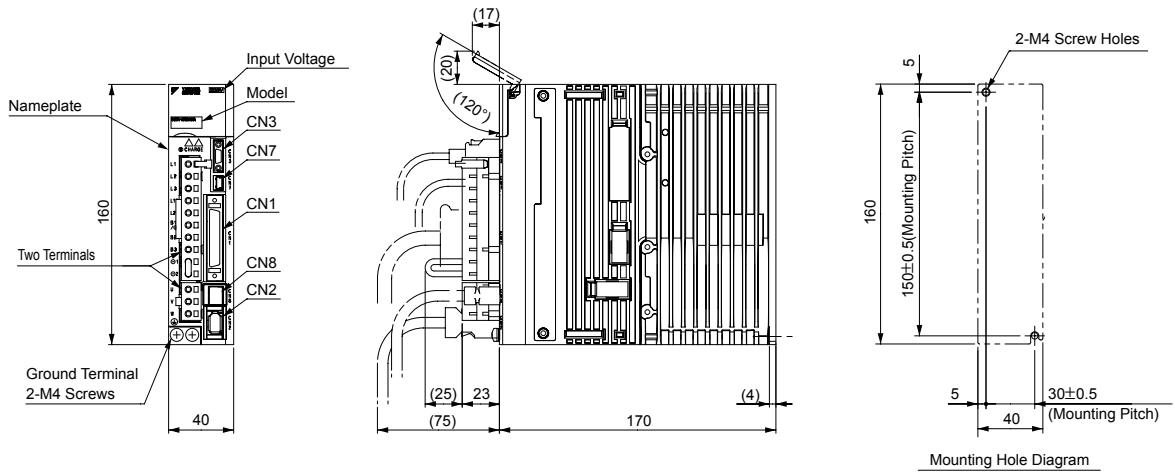

Approx. Mass: 1.0 kg

(5) Three-phase 200 VAC, Model: SGDV-3R8A0□A, -5R5A0□A, and 7R6A0□A

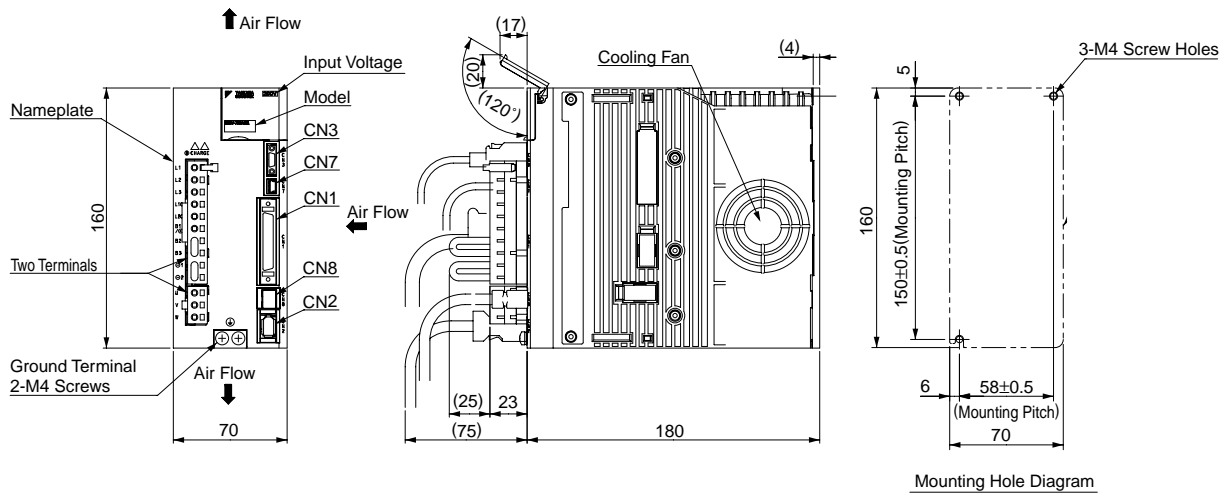

Approx. Mass: 1.5 kg

(6) Three-phase 200 VAC, Model: SGDV-120A0□A

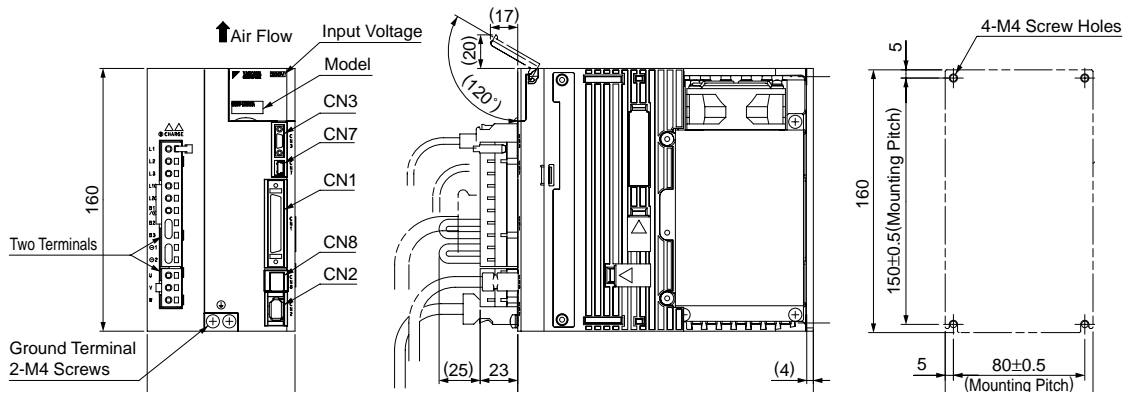

Approx. Mass: 2.4 kg

Analog/Pulse Type SERVOPACKS

**External Dimensions** Units: mm

(7) Single-phase 200 VAC, Model: SGD V-120A0□A008000 (1.5 kW, single-phase input type)  
 Three-phase 200 VAC, Model: SGD V-180A0□A and -200A0□A

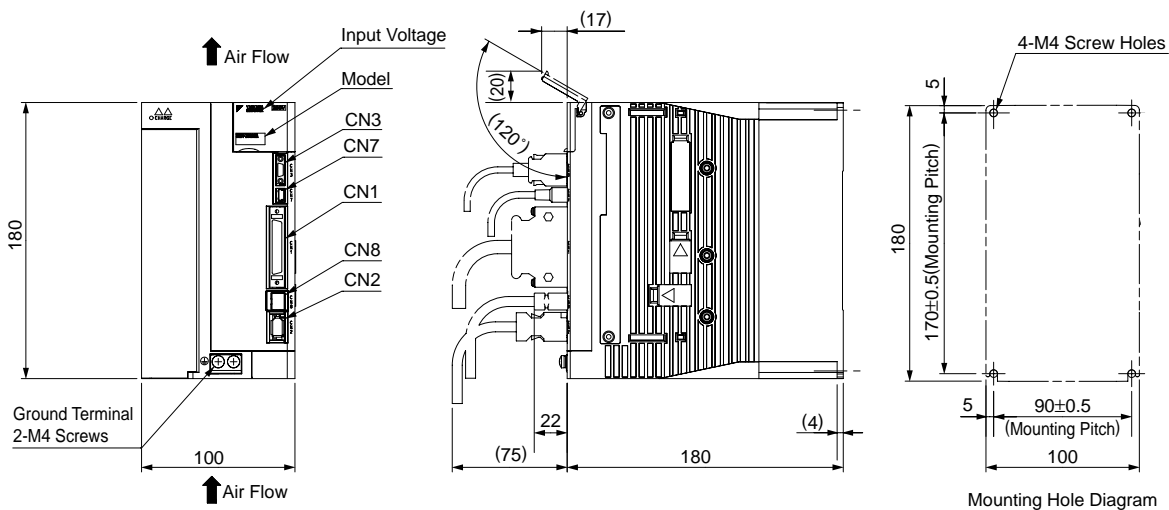

Approx. Mass: 2.8 kg

(8) Three-phase 200 VAC, Model: SGD V-330A0□A

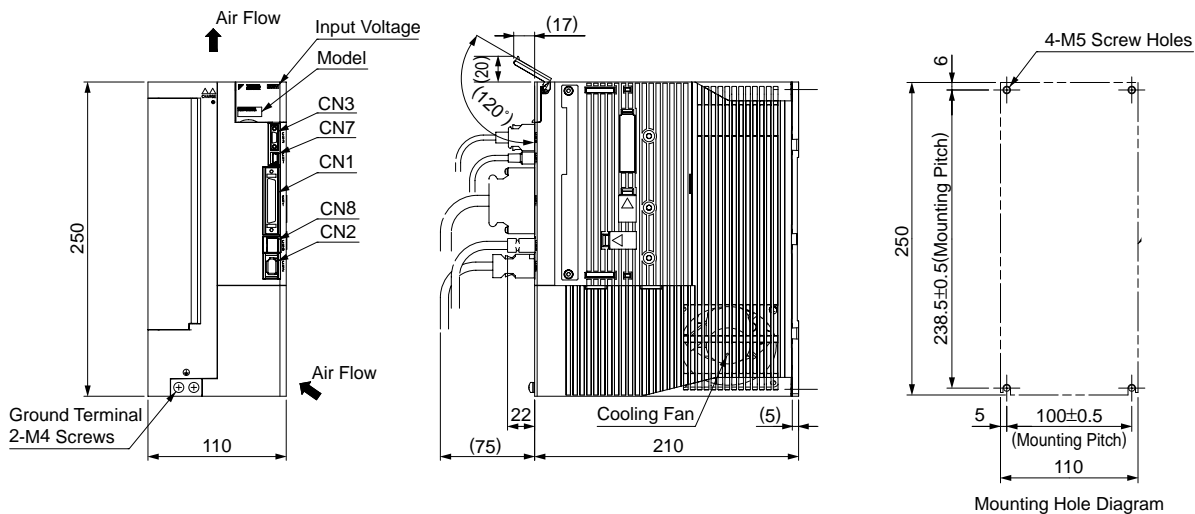

Approx. Mass: 4.6 kg

**External Dimensions** Units: mm

(9) Three-phase 200 VAC, Model: SGDV-470A0□A and -550A0□A

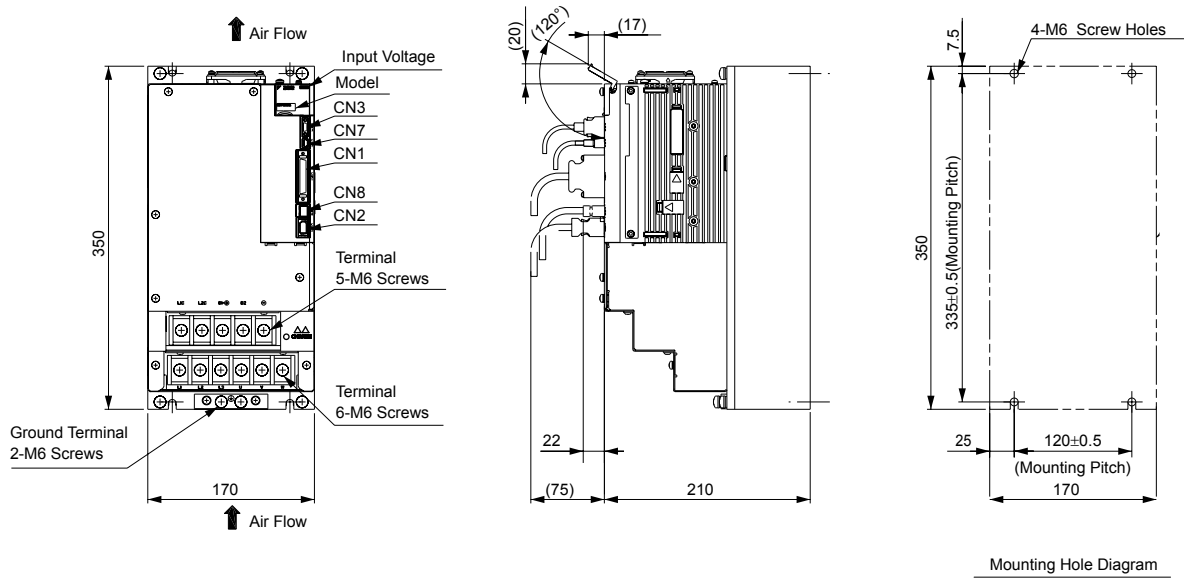

Approx. Mass: 10.2 kg

(10) Three-phase 200 VAC, Model: SGDV-590A0□A and -780A0□A

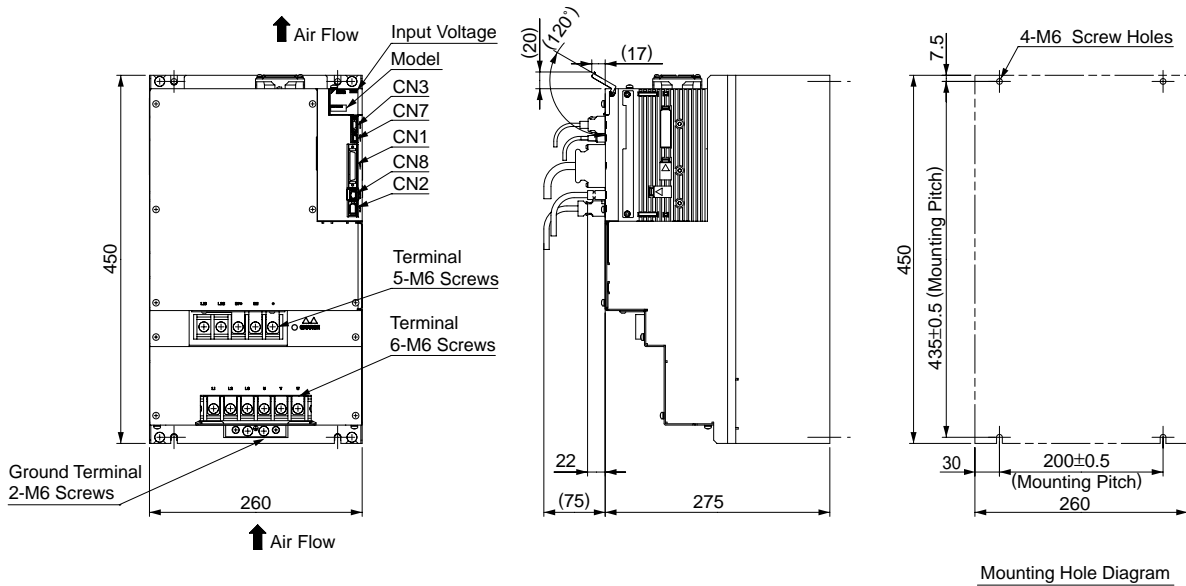

Approx. Mass: 21.0 kg

**External Dimensions** Units: mm

(11) Three-phase 400 VAC, Model: SGDV-1R9D0□A, -3R5D0□A, and -5R4D0□A

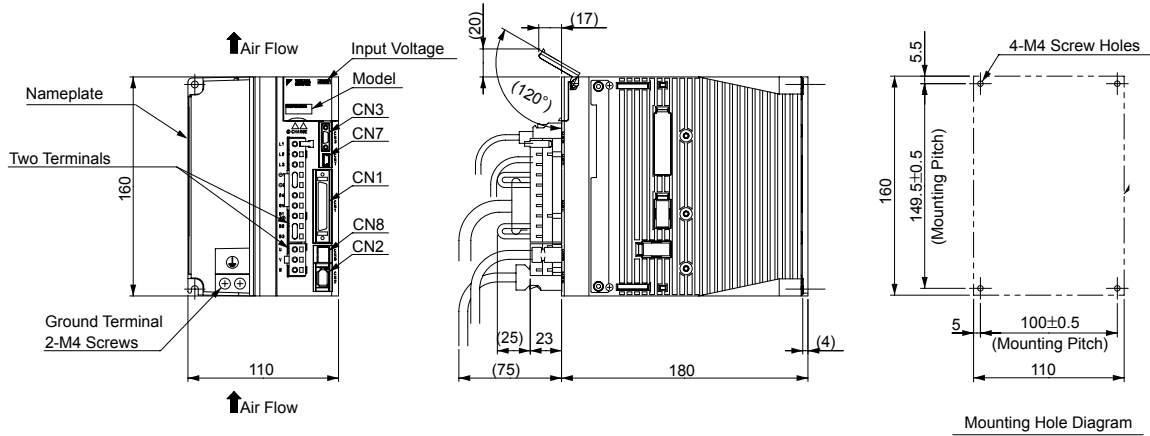

Mounting Hole Diagram

Approx. Mass: 2.7 kg

(12) Three-phase 400 VAC, Model: SGDV-8R4D0□A and -120D0□A

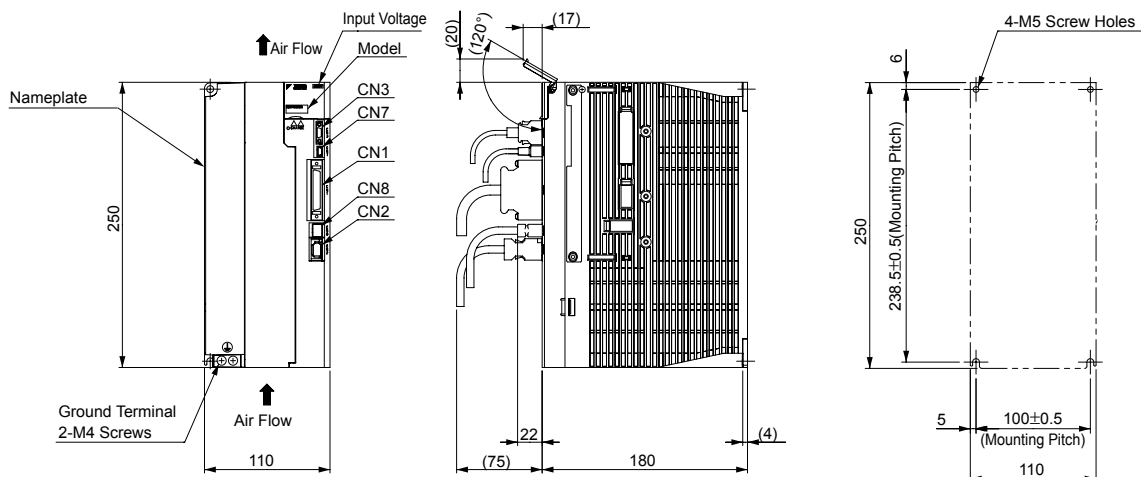

Mounting Hole Diagram

Approx. Mass: 3.7 kg

(13) Three-phase 400 VAC, Model: SGDV-170D0□A

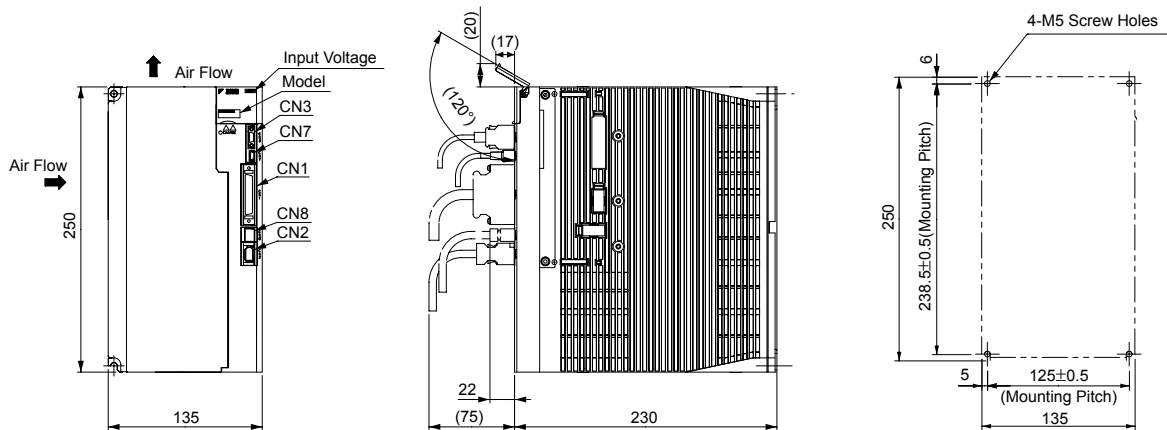

Mounting Hole Diagram

Approx. Mass: 5.6 kg

**External Dimensions** Units: mm

(14) Three-phase 400 VAC, Model: SGDV-210D0□A and -260D0□A

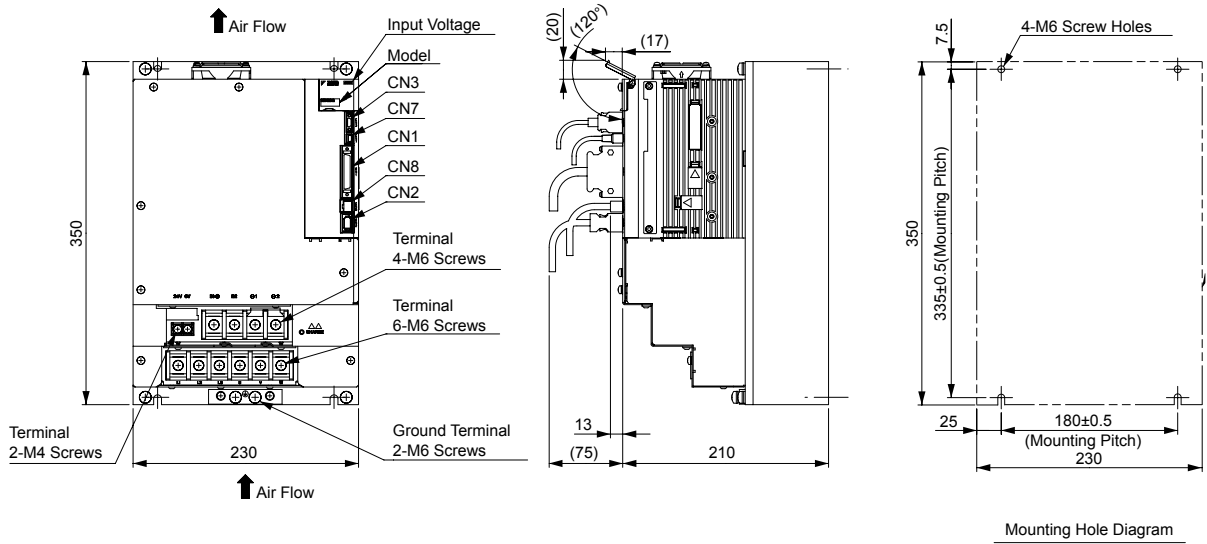

Approx. Mass: 11.3 kg

(15) Three-phase 400 VAC, Model: SGDV-280D0□A and -370D0□A

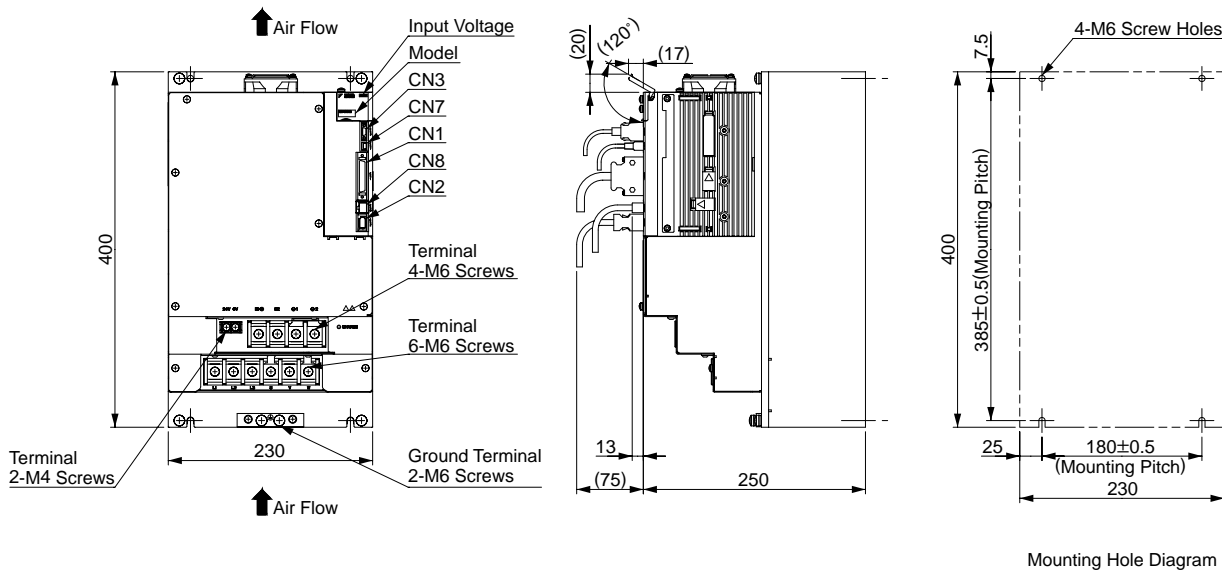

Approx. Mass: 16.2 kg

**Connectors for Base-mounted SERVOPACKS**

Port	Model	Pin	Manufacturer
CN1	10250-52A2PL	50	Sumitomo 3M Ltd.
CN2	53984-0671	6	Molex Japan Co., Ltd.
CN3	HDR-EC14LFDTN-SLE-PLUS	14	Honda Tsushin Kogyo Co., Ltd.
CN7	MNC23-5K5H00	5	ADVANCED-CONNECTEK INC.
CN8	1981080-1	8	Tyco Electronics AMP K.K.

Note: The connectors above or their equivalents are used for SERVOPACKS.

## External Dimensions Units: mm

### ● Rack-mounted SERVOPACKs (6 kW or more models: duct-ventilated)

(1) Single-phase 100 VAC, Model: SGDV-R70F0□A001, -R90F0□A001, and -2R1F0□A001

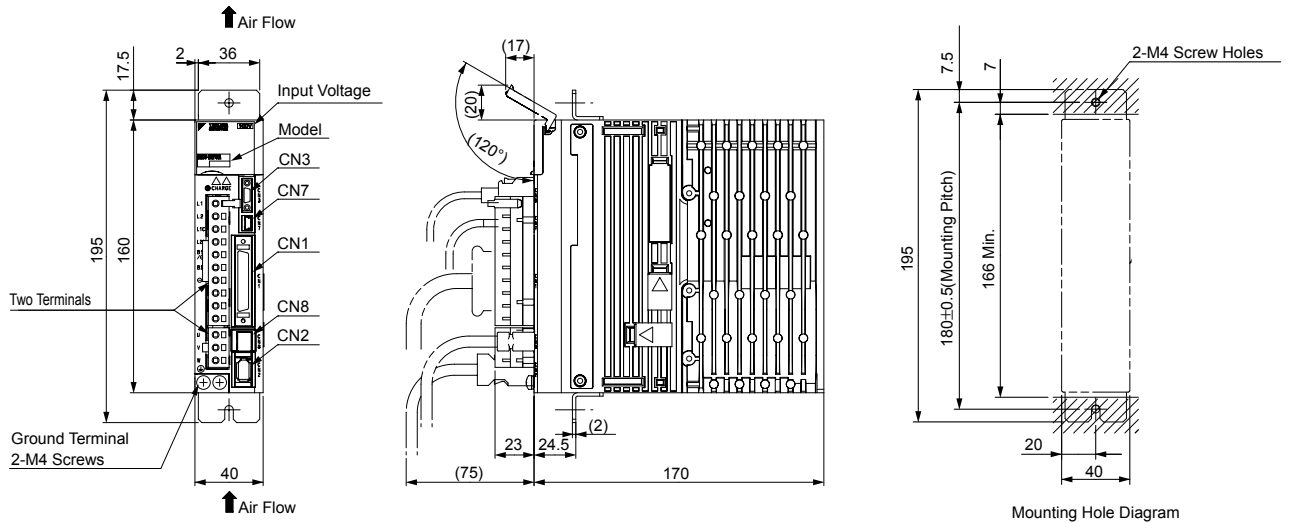

Approx. Mass: 1.1 kg

(2) Single-phase 100 VAC, Model: SGDV-2R8F0□A001

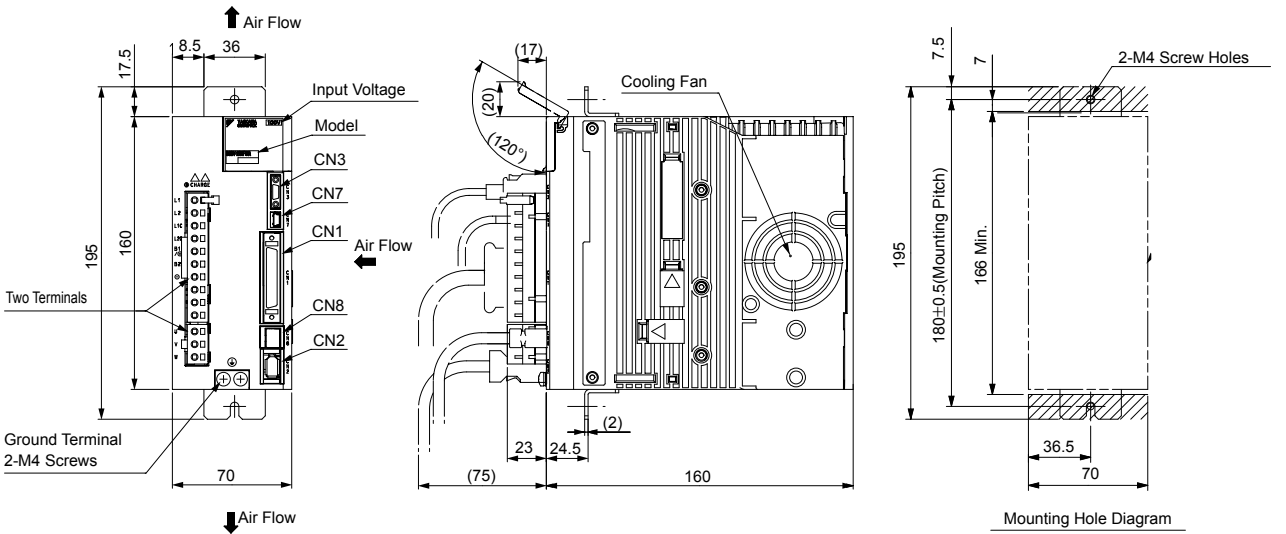

Approx. Mass: 1.5 kg

(3) Three-phase 200 VAC, Model: SGDV-R70A0□A001, -R90A0□A001, and -1R6A0□A001

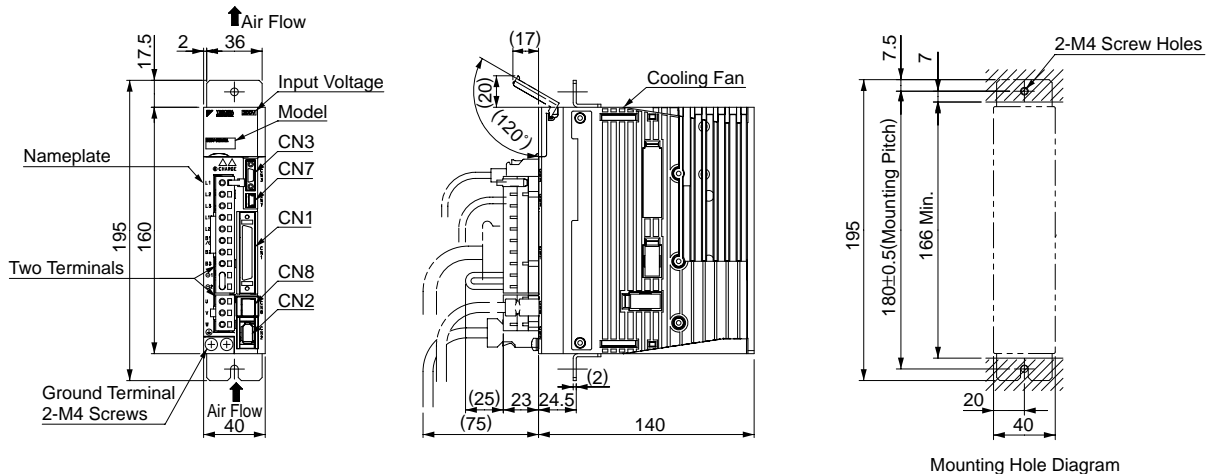

Approx. Mass: 0.9 kg

External Dimensions Units: mm

(4) Three-phase 200 VAC, Model: SGDV-2R8A0□A001

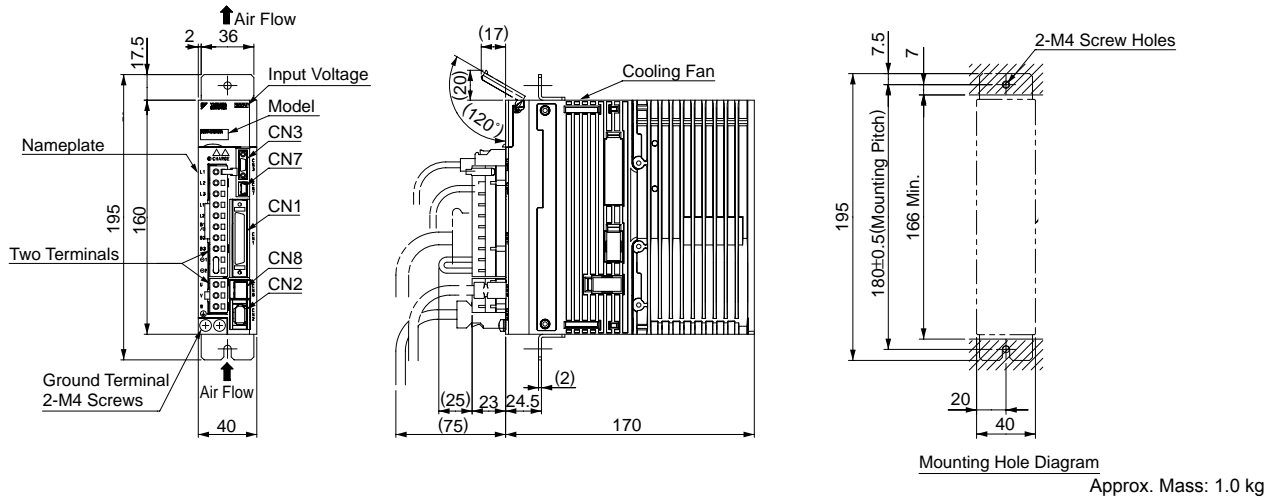

(5) Three-phase 200 VAC, Model: SGDV-3R8A0□A001, -5R5A0□A001, and -7R6A□0A001

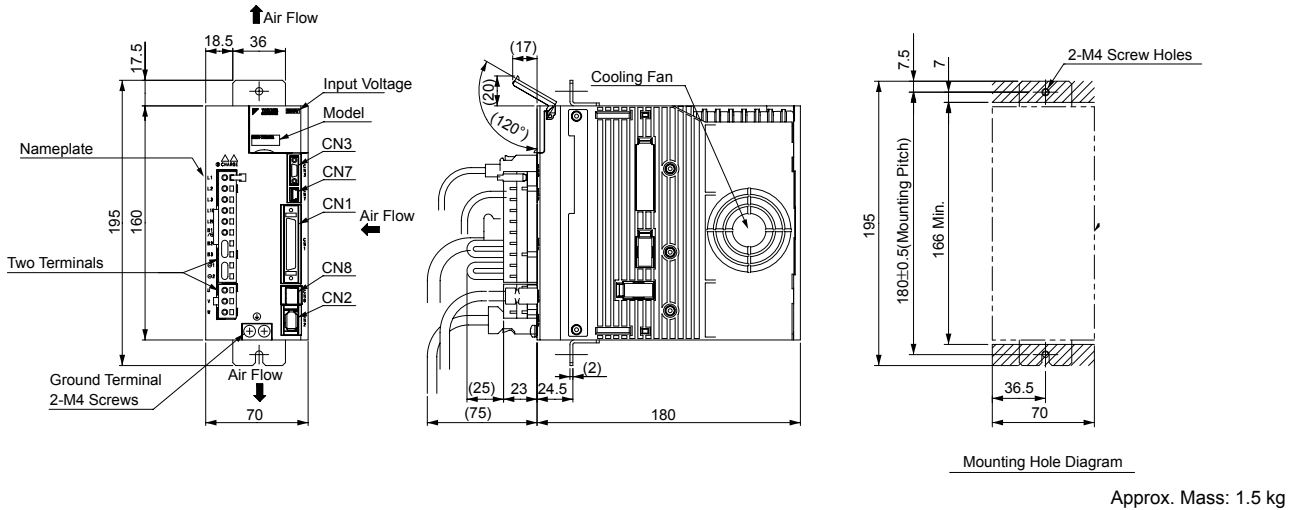

(6) Three-phase 200 VAC, Model: SGDV-120A0□A001

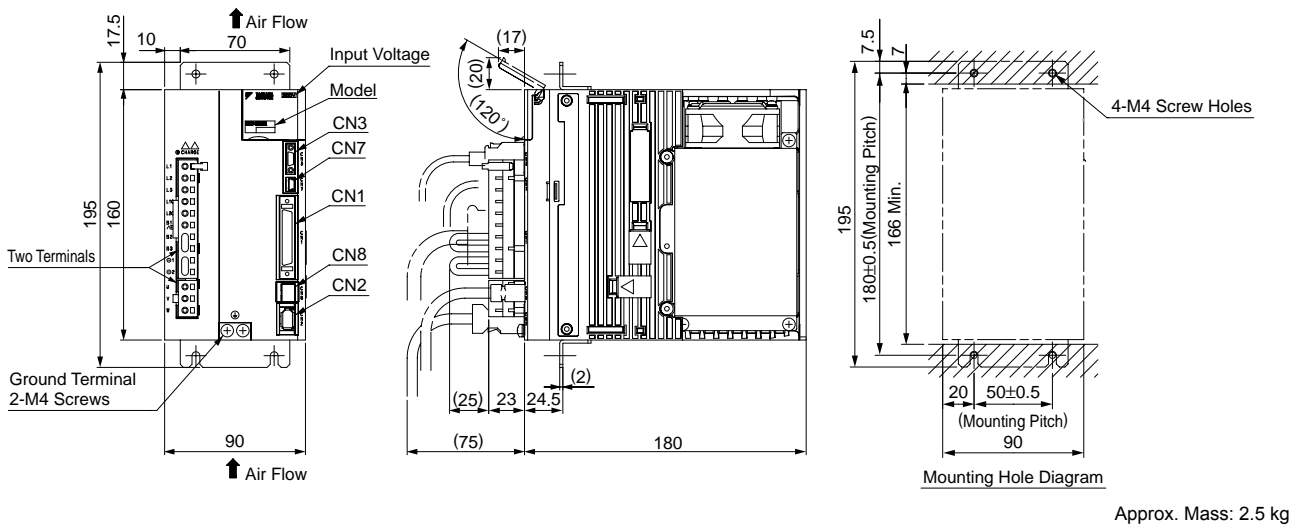



**External Dimensions** Units: mm

(7) Single-phase 200 VAC, Model: SGDV-120A0□A008000 (1.5 kW, single-phase input type)  
 Three-phase 200 VAC, Model: SGDV-180A0□A001 and -200A0□A001

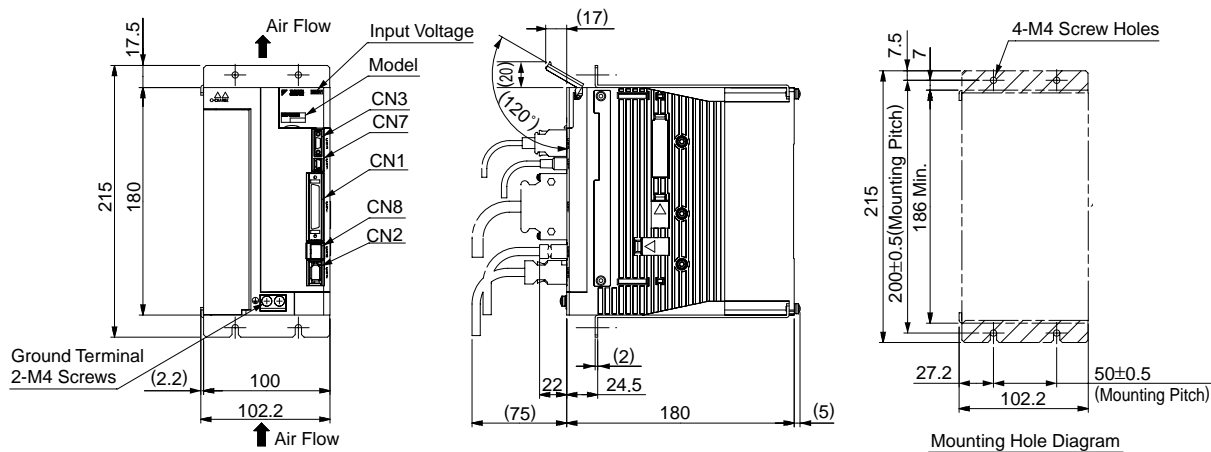

Approx. Mass: 3.1 kg

(8) Three-phase 200 VAC, Model: SGDV-330A0□A001

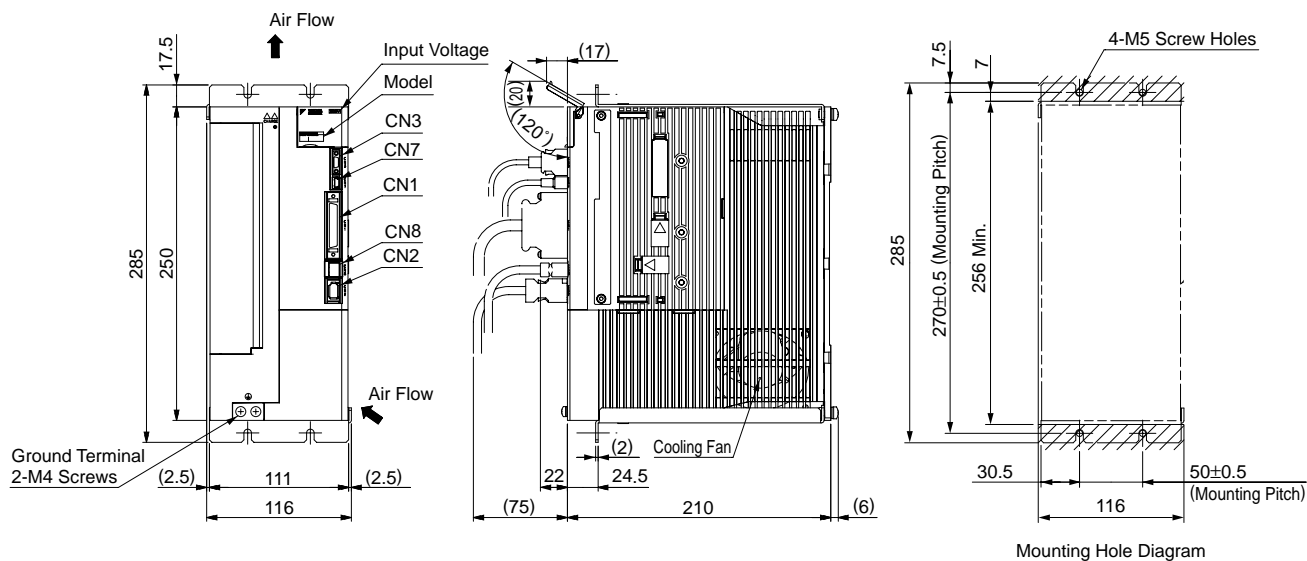

Approx. Mass: 6.0 kg

External Dimensions Units: mm

(9) Three-phase 200 VAC, SGDV-470A0□A001 and -550A□A001 (Duct-ventilated type)

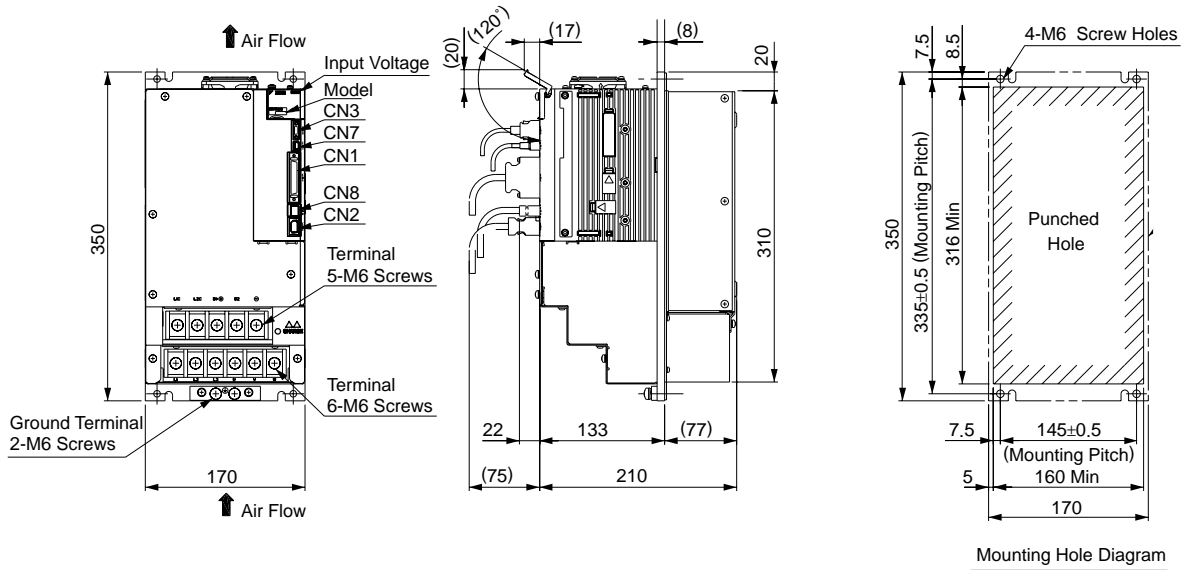

Approx. Mass: 8.5 kg

(10) Three-phase 200 VAC, SGDV-590A0□A001 and -780A□A001 (Duct-ventilated type)

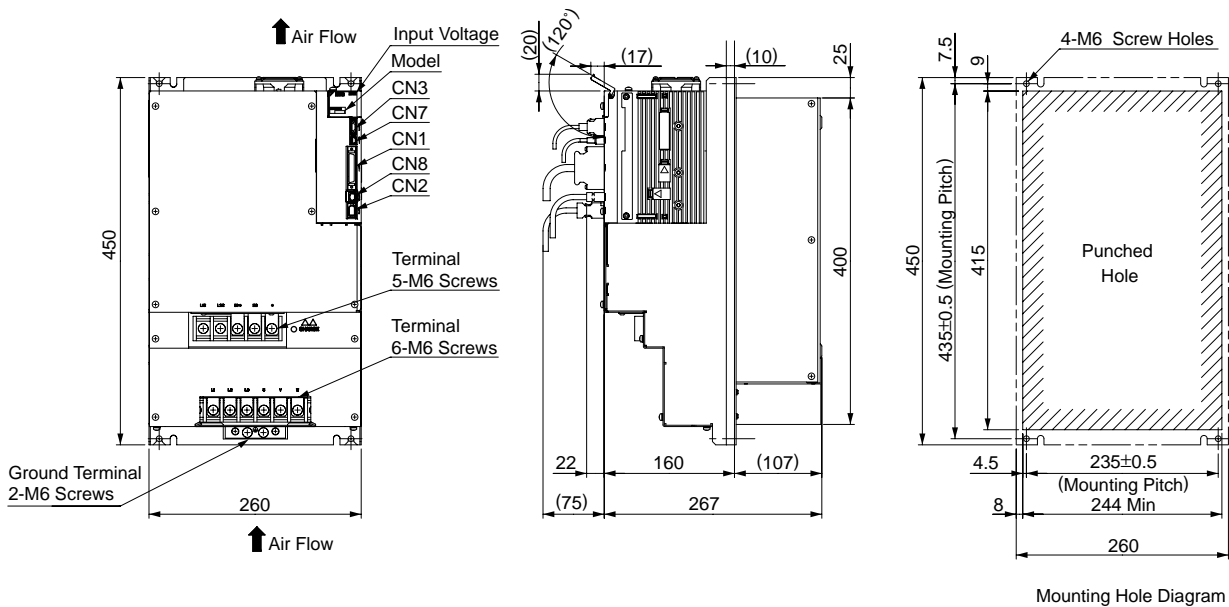

Approx. Mass: 16.0 kg

**External Dimensions** Units: mm

(11) Three-phase 400 VAC, Model: SGDV-1R9D0□A001, -3R5D0□A001, and -5R4D0□A001

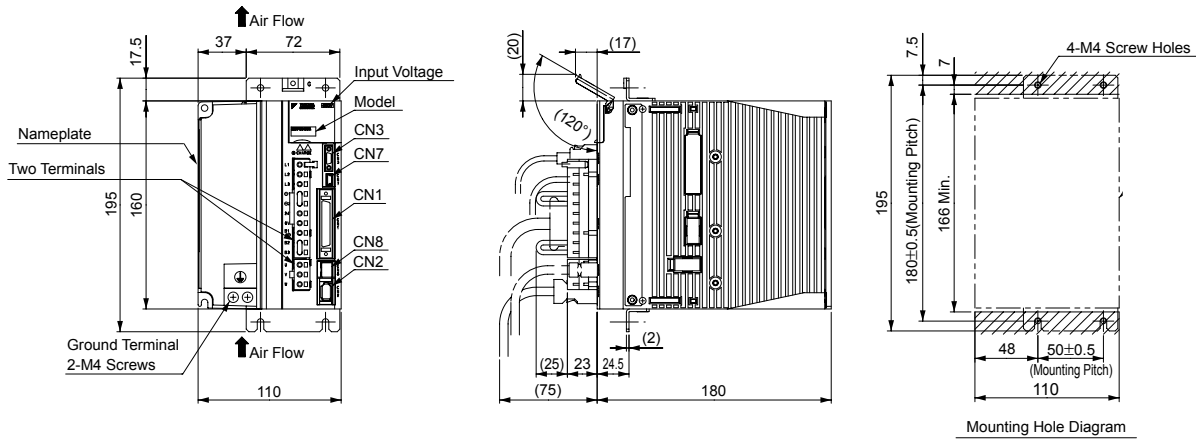

Approx. Mass: 2.7 kg

(12) Three-phase 400 VAC, Model: SGDV-8R4D0□A001 and -120D0□A001

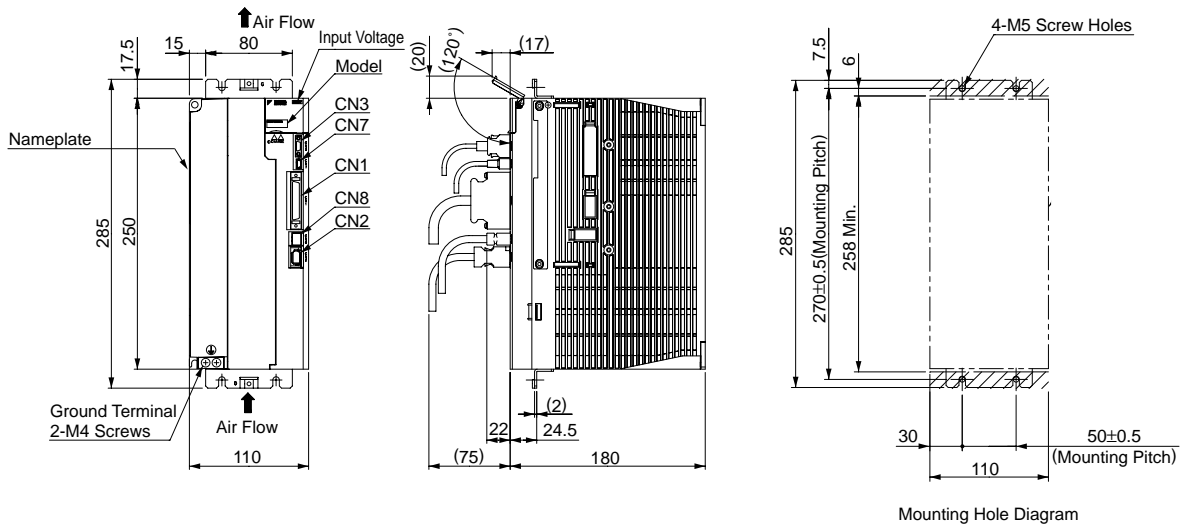

Approx. Mass: 3.8 kg

(13) Three-phase 400 VAC, Model: SGDV-170D0□A001

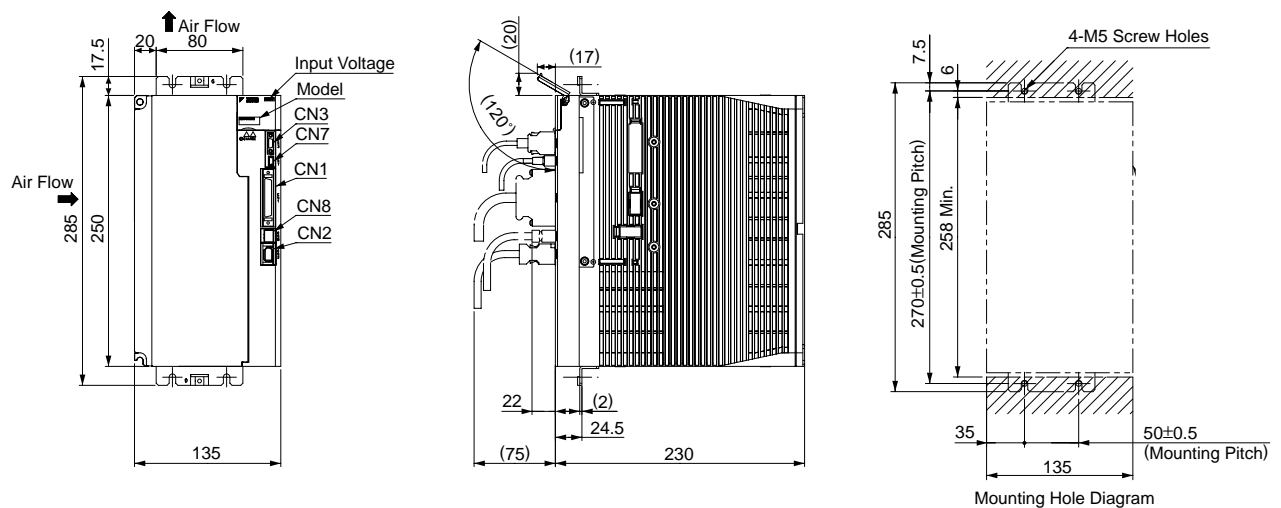

Approx. Mass: 5.7 kg

External Dimensions Units: mm

(14) Three-phase 400 VAC, Model: SGDV-210D0□A001 and -260D0□A001 (Duct-ventilated type)

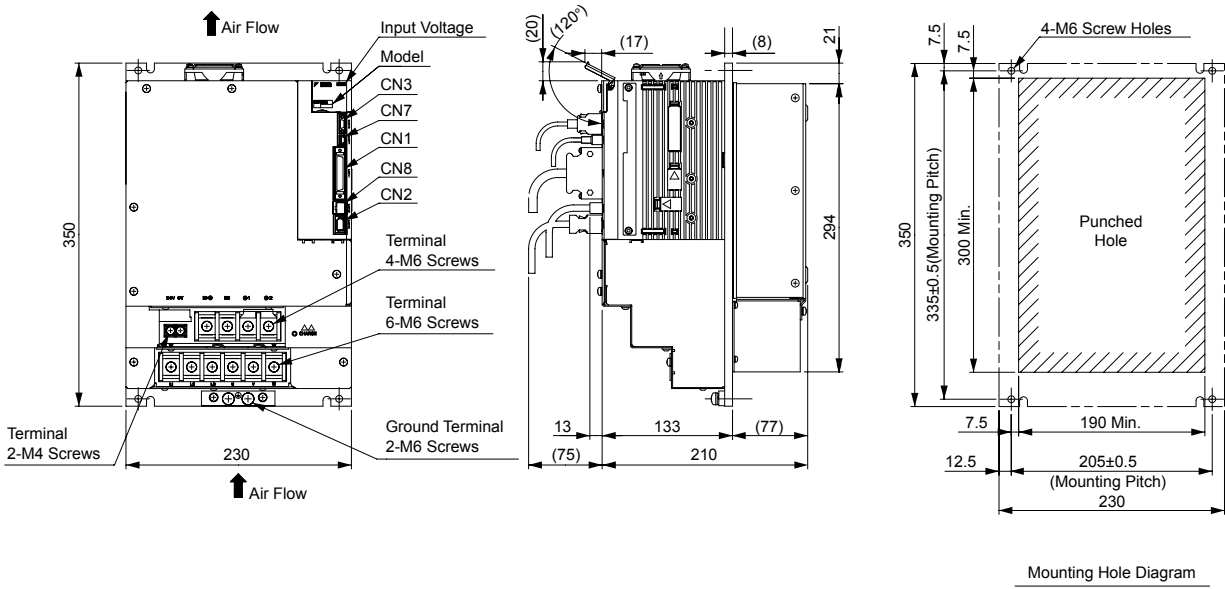

Approx. Mass: 8.1 kg

(15) Three-phase 400 VAC, Model: SGDV-280D0□A001 and -370D0□A001 (Duct-ventilated type)

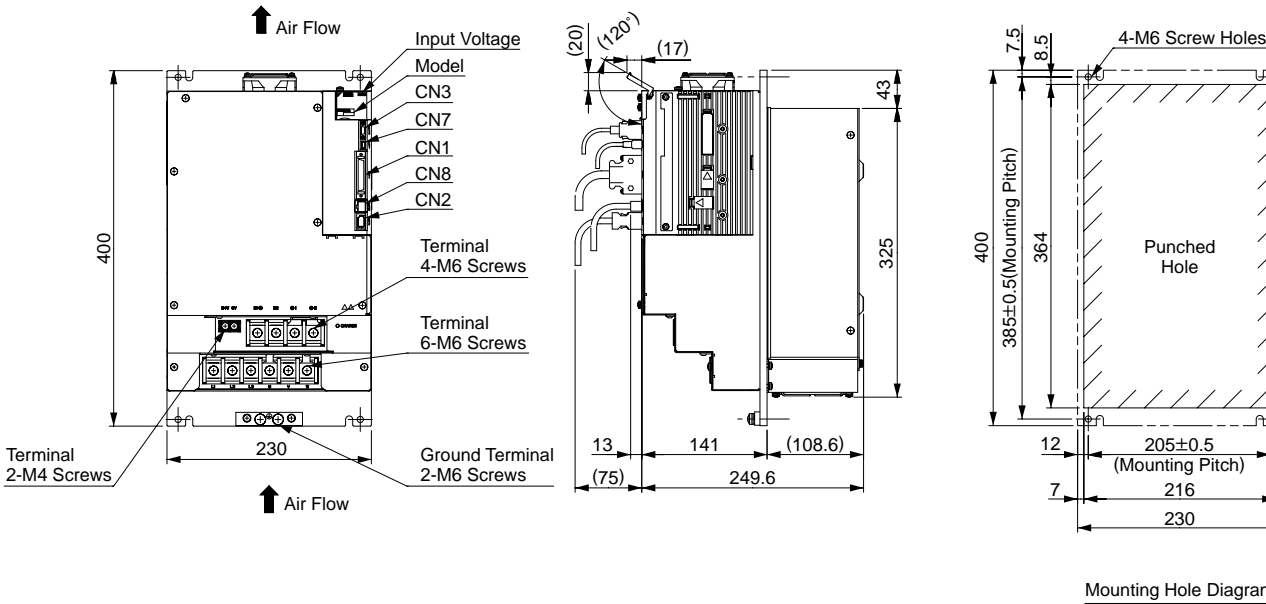

Approx. Mass: 13.6 kg

Connectors for Rack-mounted SERVOPACKS





Port	Model	Pin	Manufacturer
CN1	10250-52A2PL	50	Sumitomo 3M Ltd.
CN2	53984-0671	6	Molex Japan Co., Ltd.
CN3	HDR-EC14LFDTN-SLE-PLUS	14	Honda Tsushin Kogyo Co., Ltd.
CN7	MNC23-5K5H00	5	ADVANCED-CONNECTEK INC.
CN8	1981080-1	8	Tyco Electronics AMP K.K.

Note: The connectors above or their equivalents are used for SERVOPACKS.

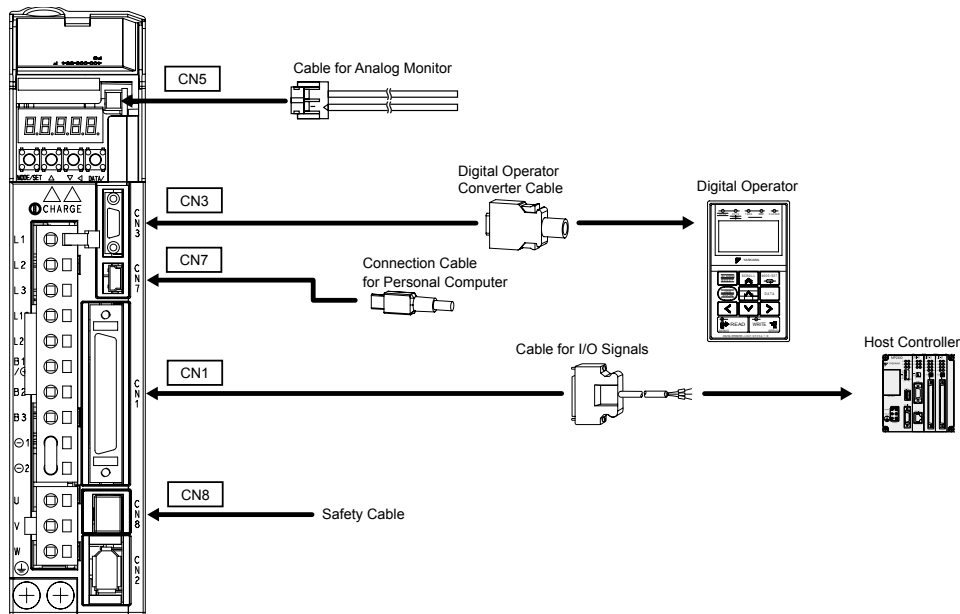
## Selecting Cables

### ● Cables for **CN1** **CN3** **CN5** **CN7** **CN8** (Analog Voltage/Pulse Train Reference Type SERVOPACKs)

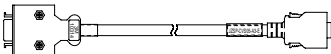

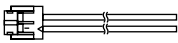
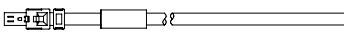
Name	Length	Order No.	Specifications	Details	
<b>CN1</b> Cables for I/O Signals	Connector Terminal Converter Unit	JUSP-TA50PG-E	Terminal Block and 0.5 m Connection Cable 	(1)	
	Cables with Loose Wires at One End	1 m	JZSP-CSI01-1-E	Cable with Loose Wires at Peripheral Devices 	(2)
		2 m	JZSP-CSI01-2-E		
	3 m	JZSP-CSI01-3-E			
<b>CN3</b>	Digital Operator	JUSP-OP05A-1-E	With Connection Cable (1 m) 	(3)	
	Digital Operator Converter Cable <sup>1</sup>	0.3 m	JZSP-CVS05-A3-E Cable with Connectors at Both Ends 	(4)	
<b>CN7</b> Connection Cables for Personal Computer	2.5 m	JZSP-CVS06-02-E	Cable with Connectors at Both Ends 	(5)	
<b>CN5</b> Cables for Analog Monitor	1 m	JZSP-CA01-E	SERVOPACK End 	(6)	
<b>CN8</b> Cables for Safety Functions	Cables with Connector <sup>2</sup>	3 m	JZSP-CVH03-03-E 	(7)	
	Connector Kit <sup>3</sup>		Contact Tyco Electronics AMP K.K. Product name: Industrial Mini I/O D-shape Type1 Plug Connector Kit Model: 2013595-1		

<sup>1</sup> : A converter cable is required to use  $\Sigma$ -III series digital operators (model: JUSP-OP05A) for  $\Sigma$ -V series SERVOPACKs.

<sup>2</sup> : When using the safety function, connect this cable to the safety devices. Even when not using the safety function, use SERVOPACKs with the Safe Jumper Connector (model: JZSP-CVH05-E) connected.

<sup>3</sup> : Use the connector kit when you make cables yourself.

Selecting Cables

(1) Connector Terminal Converter Unit for CN1

· Configurations

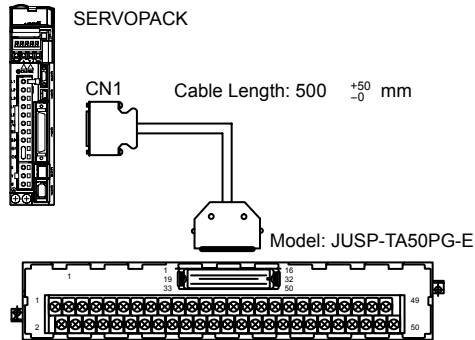

Model	Cable Length (L)
JUSP-TA50PG-E	0.5 m
JUSP-TA50PG-1-E	1 m
JUSP-TA50PG-2-E	2 m

Note: Shaded items are non-stock.

· Dimensional Drawings of Terminal Block (Units: mm)

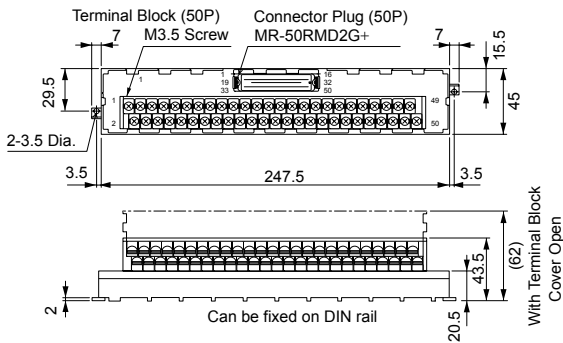

· Dimensional Drawings of Cable

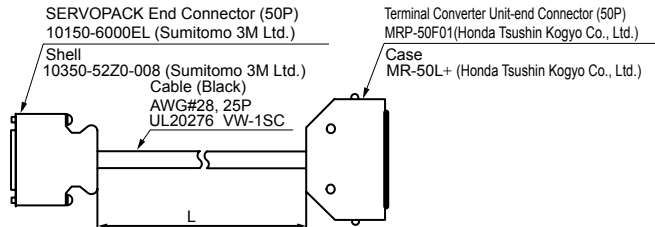

(2) Cable with Loose Wires at One End for CN1

· Dimensional Drawings of Cable

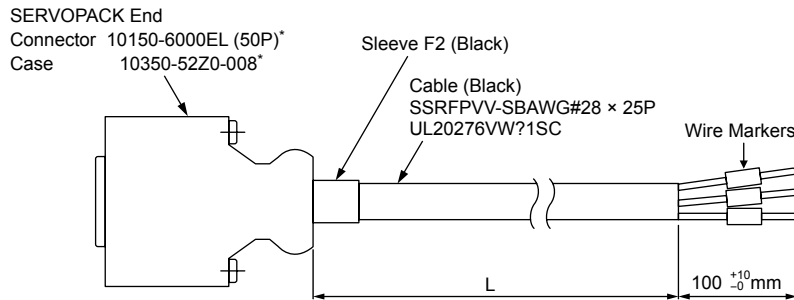

\* : Manufactured by Sumitomo 3M Ltd.

Note : See the next page for the connection diagram.

Model	Cable Length (L)
JZSP-CSI01-1-E	1 m
JZSP-CSI01-2-E	2 m
JZSP-CSI01-3-E	3 m

## Selecting Cables Units: mm

### ● Cable with Loose Wires at One End for CN1

Connection Diagram of JZSP-CSI01-□-E Cable

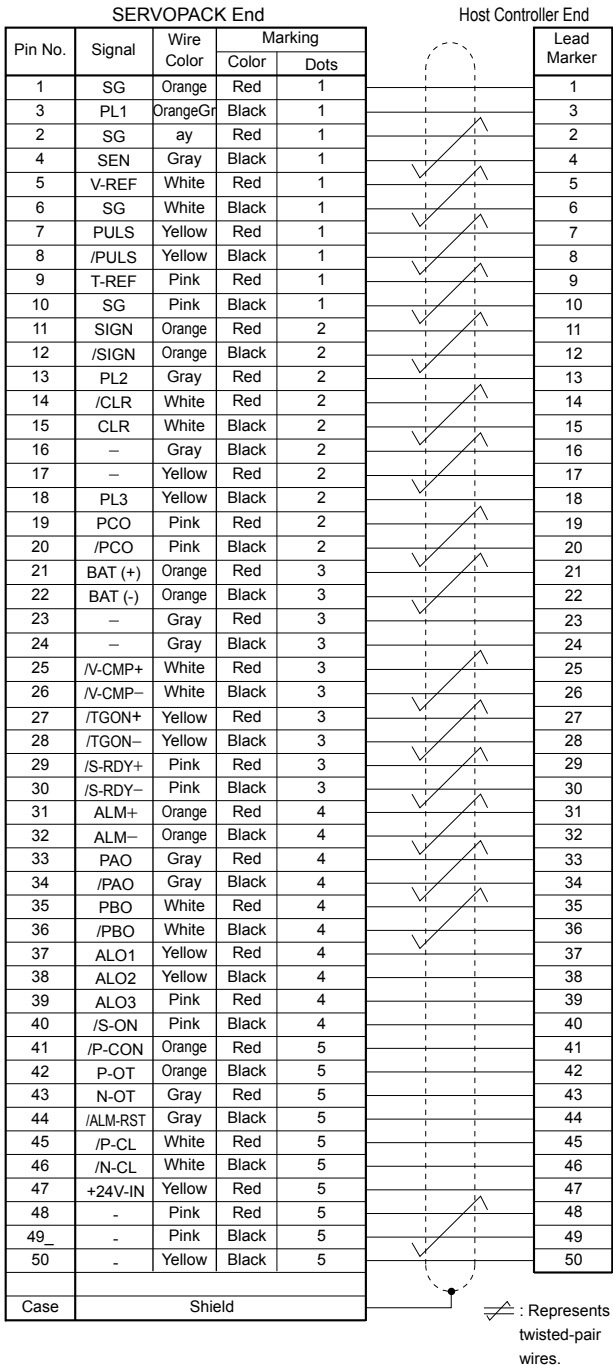

### ● Connector Kit for CN1

Use the following connector and cable to assemble the cable. The CN1 connector kit includes one case and one connector.

Connector Kit Model	Case		Connector	
	Model	Qty	Model	Qty
JZSP-CSI9-1-E	10350-52Z0-008*	1 set	10150-3000PE* (Soldered)	1

\* : Manufactured by Sumitomo 3M Ltd.

#### · Dimensional Drawings of Case

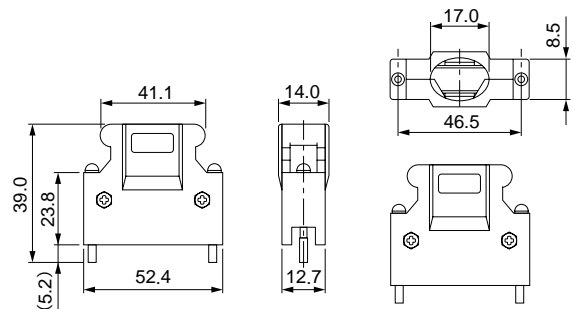

#### · Dimensional Drawings of Connector

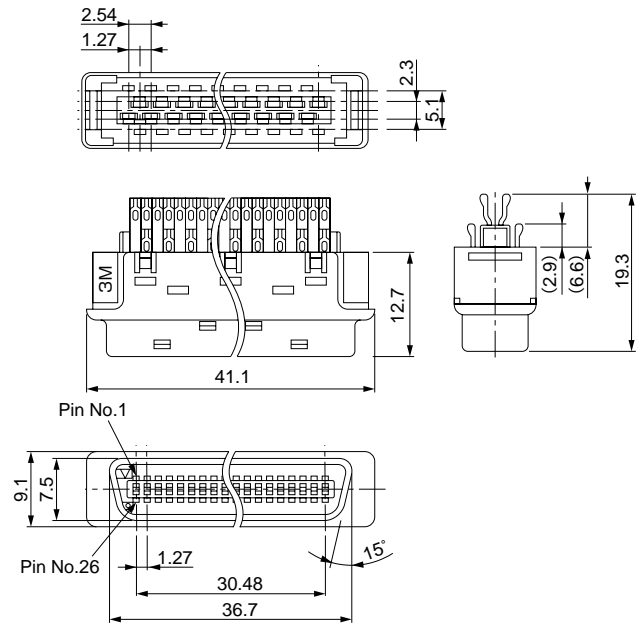

#### · Cable Size

Item	Specifications
Cable	Use twisted-pair or twisted-pair shielded wire.
Applicable Wires	AWG 24, 26, 28, 30
Cable Finished Diameter	16 dia. max.

Selecting Cables Units: mm

(3) Digital Operator (Model: JUSP-OP05A-1-E)

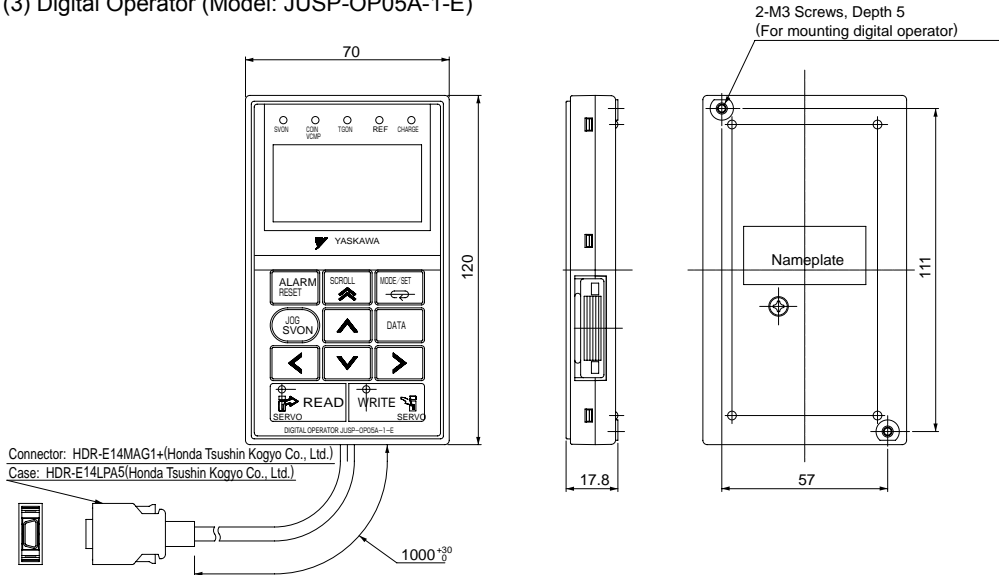

(4) Digital Operator Converter Cable for CN3  
 (Model: JZSP-CVS05-A3-E)

A converter cable is required to use  $\Sigma$ -III series digital operators (model: JUSP-OP05A) for  $\Sigma$ -V series SERVOPACKS.

· Dimensional Drawings

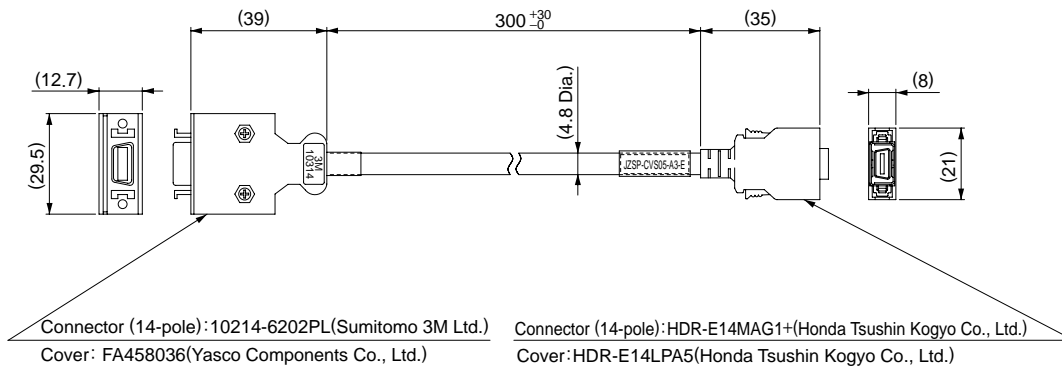

(5) Connection Cable for Personal Computer for CN7  
 (Model: JZSP-CVS06-02-E)

· Dimensional Drawings

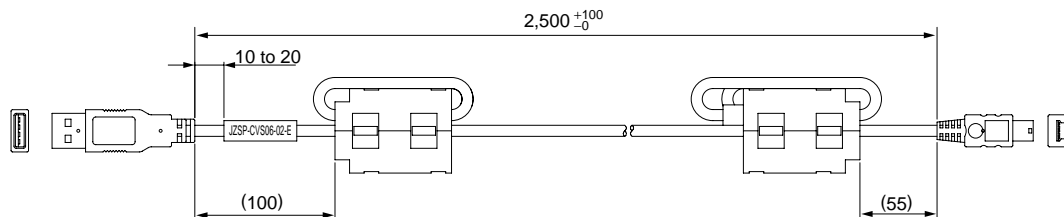

**IMPORTANT** Use a cable specified by Yaskawa.  
 When using other cables, operation cannot be guaranteed.



## Selecting Cables Units: mm

### (6) Cable for Analog Monitor for CN5 (Model: JZSP-CA01-E)

#### · Dimensional Drawings

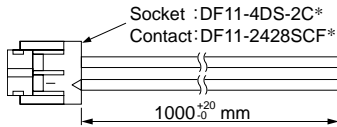

\* : Manufactured by Hirose Electric Corporation.

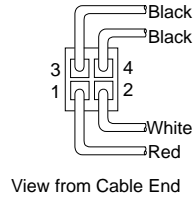

#### · Specifications

Pin No.	Cable Color	Signal	Standard Settings
1	Red	Analog Monitor 2	Motor speed : 1V/1000 min <sup>-1</sup>
2	White	Analog Monitor 1	Torque reference : 1V/100% rated torque
3, 4	Black (2 cables)	GND(0V)	-

Note : The specifications above are factory settings. Monitor specifications can be changed by changing parameters Pn006 and Pn007.

### (7) Cable with Connector for CN8 (Model: JZSP-CVH03-03-E)

#### · Dimensional Drawings

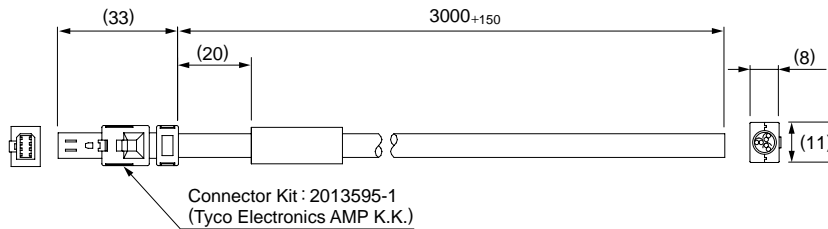

#### · Specifications

Pin No.	Signal	Lead Color	Marking Color
1	Not used	-	-
2	Not used	-	-
3	/HWBB1-	White	Black
4	/HWBB1□	White	Red
5	/HWBB2-	Gray	Black
6	/HWBB2□	Gray	Red
7	EDM1-	Orange	Black
8	EDM1□	Orange	Red



# MECHATROLINK-II Communications Reference Type SERVOPACKS

## SGDV-□□□□11 (For Rotary Servomotors)

## SGDV-□□□□15 (For Linear Servomotors)



### Model Designations

SGDV - R70 A 01 B 002000

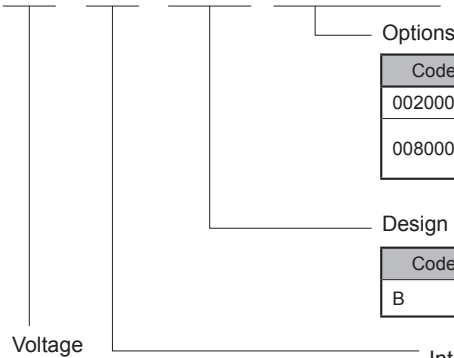
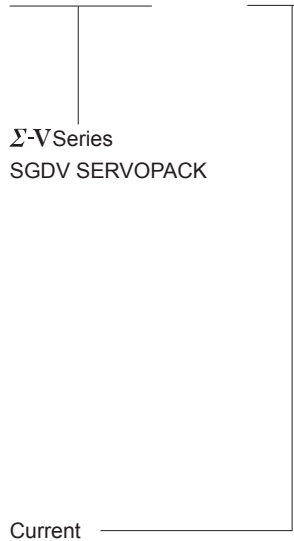

Code	Specifications
002000	Base-mounted, varnish(standard)
008000	Single-phase, 200VAC Input (model: SGDV-120A01A008000)

Code	Specifications
B	Standard

Code	Specifications
F	100 VAC
A	200 VAC
D	400 VAC

Code	Specifications
11	MECHATROLINK-II communications Reference Type (for rotary servomotors)
15	MECHATROLINK-II communications Reference Type (for linear servomotors)

Code	100 V (Single Phase)		Code	200 V (Three Phase)		Code	400 V (Three Phase)	
	Applicable Servomotor Max. Capacity kW			Applicable Servomotor Max. Capacity kW			Applicable Servomotor Max. Capacity kW	
R70	0.05		R70*	0.05		1R9	0.5	
R90	0.1		R90*	0.1		3R5	1.0	
2R1	0.2		1R6*	0.2		5R4	1.5	
2R8	0.4		2R8*	0.4		8R4	2.0	
			3R8	0.5		120	3.0	
			5R5*	0.75		170	5.0	
			7R6	1.0		210	6.0	
			120**	1.5		260	7.5	
			180	2.0		280	11	
			200	3.0		370	15	
			330	5.0				
			470	6.0				
			550	7.5				
			590	11				
			780	15				

NOTE: Shaded items are non-stock.

\* These amplifiers can be powered with single or three-phase.

\*\* SGDV-120A□1A008000, a special version of the 1.5kW amplifier can be used for single-phase operation.

# Features

## ● Real-time communications

MECHATROLINK-II communications enable high-speed control for 30 stations at a maximum transmission speed of 10 Mbps in a transmission cycle from 250  $\mu$ s to 4 ms (user setting). Such a high transmission speed allows real-time transmission of various data required for control.

## ● Cost savings

Thirty stations can be connected to a single MECHATROLINK-II transmission line, so wiring costs and time are greatly reduced. Also, only one signal connector is required on the host controller. And, the all-digital network eliminates the need for conversion from digital to analog for speed/torque references and for a pulse generator to generate position references.

## ● High-precision motion control

The SGD V SERVOPACK when connected to the host controller in the MECHATROLINK-II network provides not only torque, position, and speed control but also synchronized phase control that requires advanced control technology. The control mode can be changed online so that the machine can move smoothly in complex motions with great efficiency.

# Ratings

## Single-phase 100 V

SERVOPACK Model	SGDV-□□□□	R70F	R90F	2R1F	2R8F
Applicable Servomotor Max. Capacity	kW	0.05	0.1	0.2	0.4
Continuous Output Current	$A_{rms}$	0.66	0.91	2.1	2.8
Max. Output Current	$A_{rms}$	2.1	2.9	6.5	9.3
Main Circuit (Single Phase)		100 to 115 VAC+10% to -15% 50/60 Hz			
Control Circuit (Single Phase)		100 to 115 VAC+10% to -15% 50/60 Hz			

## Single-phase 200 V

SERVOPACK Model	SGDV-□□□□	R70A	R90A	1R6A	2R8A	5R5A	120
Applicable Servomotor Max. Capacity	kW	0.05	0.1	0.2	0.4	0.75	1.5
Continuous Output Current	$A_{rms}$	0.66	0.91	1.6	2.8	5.5	11.6
Max. Output Current	$A_{rms}$	2.1	2.9	6.5	9.3	16.9	28
Main Circuit (Single Phase)		220 to 230 VAC +10% to -15% 50/60 Hz					
Control Circuit (Single Phase)		220 to 230 VAC +10% to -15% 50/60 Hz					

## Three-phase 200 V

SERVOPACK Model	SGDV-□□□□	R70A	R90A	1R6A	2R8A	3R8A	5R5A	7R6A	120A	180A	200A	330A	470A	550A	590A	780A
Applicable Servomotor Max. Capacity	kW	0.05	0.1	0.2	0.4	0.5	0.75	1.0	1.5	2.0	3.0	5.0	6	7.5	11	15
Continuous Output Current	$A_{rms}$	0.66	0.91	1.6	2.8	3.8	5.5	7.6	11.6	18.5	19.6	32.9	46.9	54.7	58.6	78
Max. Output Current	$A_{rms}$	2.1	2.9	6.5	9.3	11	16.9	17	28	42	56	84	110	130	140	170
Main Circuit		Three-phase 200 to 230 VAC+10% to -15% 50/60 Hz														
Control Circuit		Single-phase 200 to 230 VAC+10% to -15% 50/60 Hz														

## Three-phase 400 V

SERVOPACK Model	SGDV-□□□□	1R9D	3R5D	5R4D	8R4D	120D	170D	210D	260D	280D	370D
Applicable Servomotor Max. Capacity	kW	0.5	1.0	1.5	2.0	3.0	5.0	6	7.5	11	15
Continuous Output Current	$A_{rms}$	1.9	3.5	5.4	8.4	11.9	16.5	20.8	25.4	28.1	37.2
Max. Output Current	$A_{rms}$	5.5	8.5	14	20	28	42	55	65	70	85
Main Circuit		Three-phase 380 to 480 VAC+10% to -15% 50/60 Hz									
Control Circuit		24 VDC $\pm$ 15%									

## ● SERVOPACK Overload Characteristics

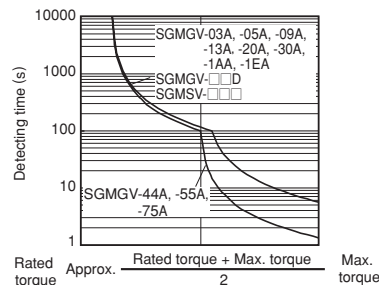
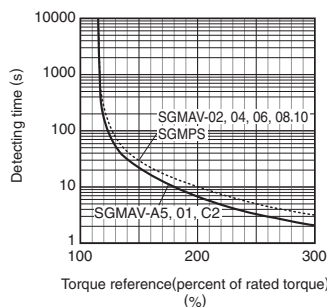
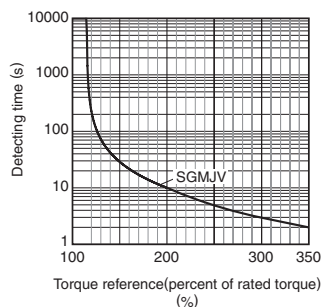

Note: Overload characteristics shown above do not guarantee continuous duty of 100% or more output. Use a servomotor with effective torque within the continuous duty zone of Torque-Motor Speed Characteristics.

## Specifications

Items		Specifications	
Input Power Supply	Main Circuit	100 V	Single-phase 100 to 115 VAC + 10% to - 15% 50/60 Hz
		200 V	Three-phase 200 to 230 VAC + 10% to - 15% 50/60 Hz
		400 V	Three-phase 380 to 480 VAC + 10% to - 15% 50/60 Hz
	Control Circuit	100 V	Single-phase 100 to 115 VAC + 10% to - 15% 50/60 Hz
		200 V	Single-phase 200 to 230 VAC + 10% to - 15% 50/60 Hz
		400 V	24 VDC ± 15%
Control Method		For 100 V, for 200 V, for 400 V, single-phase or three-phase full-wave rectification IGBT PWM control, sine-wave driven	
Feedback	Rotary Servomotors		Serial encoder: 13-bit (incremental encoder) : 17-bit (incremental/absolute encoder) : 20-bit (incremental/absolute encoder)
	Linear Servomotors		Serial converter or serial data
Operating Conditions	Surrounding/Storage Temperature		Surrounding temperature: 0 to +55°C, storage temperature: -20 to +85°C
	Ambient/Storage Humidity		90%RH or less (no condensation)
	Vibration/Shock Resistance		Vibration resistance: 4.9 m/s <sup>2</sup> , Shock resistance: 19.8 m/s <sup>2</sup>
	Protection class/Pollution degree		Protection class: IP 1X, pollution degree: 2 Do not use SERVOPACKS in the following locations: ·Locations subject to corrosive or flammable gases ·Locations subject to exposure to water, oil, or chemicals ·Locations subject to dust, including iron dust, and salts
	Others		Do not use SERVOPACKS in the following locations: ·Locations subject to static electricity noise, strong electromagnetic/magnetic fields, radioactivity
	Elevation		1000 m or less
Compliant Standards		UL 508C EN50178, EN55011 class A group 1, EN61800-3, EN61800-5-1	
Configuration		Base-mounted (Rack-mounting available as an option for some models. 6 kW or more models are duct-ventilated.)	
Performance	Speed Control Range		1:5000 (The lowest speed of the speed control range is the speed at which the servomotor will not stop with a rated torque load.)
	Speed Regulation*	Load Regulation	0% to 100% load: ±0.01% max. (at rated speed)
		Voltage Regulation	Rated voltage: ±10% : 0% (at rated speed)
		Temperature Regulation	25 ± 25°C : ±0.1% max. (at rated speed)
	Torque Control Tolerance (Repeatability)		±1%
Soft Start Time Setting		0 to 10 s (can be set individually for acceleration and deceleration.)	
I/O Signals	Encoder Output Pulses		Phase A, phase B, phase C: line driver output The number of dividing pulse: Any setting ratio is available.
Communications	RS-422A Communications	Interface	Digital operator, RS-422A port of personal computers etc.
		1:N communications	RS-422A port: N= 15 max. available
		Axis address setting	Set by parameters
	USB Communications	Function	Status display, parameter settings, adjustment functions, utility functions
		Interface	Personal computers (application: engineering tool SigmaWin+)
	1:N communications	Compliant with USB1.1 standard	
	Function	Status display, parameter settings, adjustment functions, utility functions	
Display	Power Charge		CHARGE for main circuit power supply input confirmation One LED (orange)
Analog Monitor		Analog monitor connector built in for monitoring speed, torque and other reference signals. Number of points: 2	
Protective Functions		Overcurrent, Overvoltage, low voltage, overload, regeneration error	
Utility Functions		Alarm history, JOG operation, origin search, etc.	
Regenerative Processing		100 VAC model: External regenerative resistor (optional) 200 VAC SGDV-R70A, -R90A, -1R6A, -2R8A: External regenerative resistor (optional) 200 VAC SGDV-470A, -550A, -590A, -780A: External regenerative resistor unit (optional) 200 VAC models other than shown above: Built-in regenerative resistor 400 VAC SGDV-210D, -260D, -280D, -370D: External regenerative resistor unit (optional) 400 VAC models other than shown above: Built-in regenerative resistor	
Safety Functions	Input		/HWBB1, /HWBB2: Hard wire base block signal
	Output		EDM1: Status monitor (fixed output) of built-in safety circuit
	Compliant Standards		EN954 category 3 Stop category 0, IEC61508 SIL 2
Option Card Function	Feedback		Serial encoder communications input for fully-closed loop control

\*: Speed regulation is defined as follows:

$$\text{Speed regulation} = \frac{\text{No-load motor speed} - \text{Total load motor speed}}{\text{Rated motor speed}} \times 100\%$$

The motor speed may change due to voltage variations or temperature variation. The ratio of speed changes to the rated speed represent speed regulation due to voltage and temperature variations.

## Specifications

### ● Rotary Servomotors

Items		Specifications			
I/O Signal	Encoder Output Pulses		Phase A, phase B, phase C: line driver output The number of dividing pulse: Any setting ratio is available.		
	Sequence Input	Number of Channels	7 channels		
		Function	Signal allocations and positive/negative logics can be modified. Homing deceleration switch signal (/DEC), external latch signal (/EXT1 to 3), forward run prohibited (P-OT), reverse run prohibited (N-OT), forward current limit (/P-CL), reverse current limit (/N-CL)		
	Sequence Output	Fixed Output	Servo alarm (ALM)		
		Output Signals which can be allocated	<table border="1" style="width: 100%;"> <tr> <td>Number of Channels</td> <td>3 channels</td> </tr> <tr> <td>Function</td> <td>Signal allocations and positive/negative logics can be modified. Positioning completion (/COIN), speed coincidence detection (/V-CMP), servomotor rotation detection (/TGON), servo ready (/S-RDY), torque limit detection (/CLT), speed limit detection (/VLT), brake interlock (/BK), warning (/WARN), NEAR (/NEAR)</td> </tr> </table>	Number of Channels	3 channels
Number of Channels	3 channels				
Function	Signal allocations and positive/negative logics can be modified. Positioning completion (/COIN), speed coincidence detection (/V-CMP), servomotor rotation detection (/TGON), servo ready (/S-RDY), torque limit detection (/CLT), speed limit detection (/VLT), brake interlock (/BK), warning (/WARN), NEAR (/NEAR)				
Panel Operator		Display	7-segment 1-digit LED (red)		
		Switch	Rotary switch: 16 positions, DIP switch: 4 poles		
MECHATROLINK Communications		Communications Protocol	MECHATROLINK-II      MECHATROLINK-I		
		Transmission Speed	10 Mbps      4 Mbps		
		Transmission Cycle	250 μs, 0.5 to 4.0 ms (multiple of 0.5 ms)      2 ms		
		Number of Words for Link Transmission	Can be switched between 17-bytes /station and 32-bytes / station.      17-bytes /station		
		Station Address	41H to 5FH (max. number of slaves: 30)		
Command Method		Performance	Position control, speed control, and torque control through MECHATROLINK communications		
		Command Input	MECHATROLINK commands (for sequence, motion, data setting/reference, monitor, adjustment, and other commands.)		

### ● Linear Servomotors

Items		Specifications			
I/O Signal	Encoder Output Pulses		Phase A, phase B, phase C: line driver output The number of dividing pulse: Any setting ratio is available.		
	Sequence Input	Number of Channels	7 channels		
		Function	Signal allocations and positive/negative logics can be modified. Homing deceleration switch signal (/DEC), external latch signal (/EXT1 to 3), forward run prohibited (P-OT), reverse run prohibited (N-OT), forward current limit (/P-CL), reverse current limit (/N-CL)		
	Sequence Output	Fixed Output	Servo alarm (ALM)		
		Output Signals which can be allocated	<table border="1" style="width: 100%;"> <tr> <td>Number of Channels</td> <td>3 channels</td> </tr> <tr> <td>Function</td> <td>Signal allocations and positive/negative logics can be modified. Positioning completion (/COIN), speed coincidence detection (/V-CMP), servomotor movement detection (/TGON), servo ready (/S-RDY), force limit detection (/CLT), speed limit detection (/VLT), brake interlock (/BK), warning (/WARN), NEAR (/NEAR)</td> </tr> </table>	Number of Channels	3 channels
Number of Channels	3 channels				
Function	Signal allocations and positive/negative logics can be modified. Positioning completion (/COIN), speed coincidence detection (/V-CMP), servomotor movement detection (/TGON), servo ready (/S-RDY), force limit detection (/CLT), speed limit detection (/VLT), brake interlock (/BK), warning (/WARN), NEAR (/NEAR)				
Panel Operator		Display	7-segment 1-digit LED (red)		
		Switch	Rotary switch: 16 positions, piano switch: 4 poles		
MECHATROLINK Communications		Communications Protocol	MECHATROLINK-II      MECHATROLINK-I		
		Transmission Speed	10 Mbps      4 Mbps		
		Transmission Cycle	250 μs, 0.5 to 4.0 ms (multiple of 0.5 ms)      2 ms		
		Number of Words for Link Transmission	Can be switched between 17-bytes /station and 32-bytes / station.      17-bytes /station		
		Station Address	41H to 5FH (max. number of slaves: 30)		
Command Method		Performance	Position control, speed control, and force control through MECHATROLINK-II communications		
		Command Input	MECHATROLINK commands and MECHATROLINK-II commands (for sequence, motion, data setting/reference, monitor, adjustment, and other commands.)		

## Power Supply Capacities and Power Losses

The following table shows SERVOPACK's power supply capacities and power losses at the rated output.

Main Circuit Power Supply	Applicable Servomotor Max. Capacity kW	SERVOPACK Model SGD V-	Power Supply Capacity kVA	Output Current A	Main Circuit Power Loss W	Regenerative Resistor Power Loss W	Control Circuit Power Loss W	Total Power Loss W
Signal-phase 100 V	0.05	R70F	0.2	0.66	5.4	—	17	22.4
	0.1	R90F	0.3	0.91	7.8			24.8
	0.2	2R1F	0.7	2.1	14.4			31.4
	0.4	2R8F	1.4	2.8	25.6			42.6
Single-phase 200 V	0.05	R70A	0.2	0.66	5.2	—	17	22.2
	0.1	R90A	0.3	0.91	7.4			24.4
	0.2	1R6A	0.7	1.6	13.7			30.7
	0.4	2R8A	1.2	2.8	24.9			41.9
	0.75	5R5A	1.9	5.5	52.7	8	77.7	
	1.5	120A	4	11.6	68.2	10	22	100.2
Three-phase 200 V	0.05	R70A	0.2	0.66	5.1	—	17	22.1
	0.1	R90A	0.3	0.91	7.3			24.3
	0.2	1R6A	0.6	1.6	13.5			30.5
	0.4	2R8A	1	2.8	24.0			41.0
	0.5	3R8A	1.4	3.8	20.1	8	17	45.1
	0.75	5R5A	1.6	5.5	43.8			68.8
	1.0	7R6A	2.3	7.6	53.6			78.6
	1.5	120A	3.2	11.6	65.8	10	22	97.8
	2.0	180A	4	18.5	111.9	16		149.9
	3.0	200A	5.9	19.6	113.8	36	27	161.4
	5.0	330A	7.5	32.9	263.7			326.7
	6.0	470A	10.7	46.9	279.4			(180) <sup>*1</sup>
	7.5	550A	14.6	54.7	357.8	(350) <sup>*2</sup>	48	390.8
	11	590A	21.7	58.6	431.7			479.7
	15	780A	29.6	78	599.0			647.0
Three-phase 400 V	0.5	1R9D	1.1	1.9	24.6	14	21	59.6
	1.0	3R5D	2.3	3.5	46.1			81.1
	1.5	5R4D	3.5	5.4	71.3			106.3
	2.0	8R4D	4.5	8.4	77.9	28	25	130.9
	3.0	120D	7.1	11.9	108.7			161.7
	5.0	170D	11.7	16.5	161.1	36	24	221.1
	6.0	210D	12.4	20.8	172.7			(180) <sup>*3</sup>
	7.5	260D	14.4	25.7	218.6	(350) <sup>*4</sup>	30	245.6
	11	280D	21.9	28.1	294.6			324.6
15	370D	30.6	37.2	403.8	433.8			

\*1: For the optional JUSP-RA04-E regenerative resistor unit.

\*2: For the optional JUSP-RA05-E regenerative resistor unit.

\*3: For the optional JUSP-RA18-E regenerative resistor unit.

\*4: For the optional JUSP-RA19-E regenerative resistor unit.

Notes: 1 SGD V-R70F, -R90F, -2R1F, -2R8F, -R70A, -R90A, -1R6A, and -2R8A SERVOPACKs do not have built-in regenerative resistors.

If the regenerative energy exceeds the specified value, connect an external regenerative resistor (optional).

2 SGD V-470A, -550A, -590A, -780A, -210D, -260D, -280D, -370D SERVOPACKs do not have built-in regenerative resistors.

Be sure to connect a regenerative resistor unit (optional) or an external regenerative resistor (optional).

3 Regenerative resistor power losses are allowable losses. Take the following action if this value is exceeded.

· Remove the lead or short bar that is short-circuiting the SERVOPACK main circuit terminal B2 and B3.

(SGDV-3R8A, -5R5A, -7R6A, -120A, -180A, -200A, -330A, or 400-V class SERVOPACKs.)

· Install an external regenerative resistor (optional).

External Dimensions Units: mm

● Base-mounted SERVOPACKs

(1) Single-phase 100 VAC, Model: SGDV-R70F1□A, -R90F1□A, and -2R1F1□A

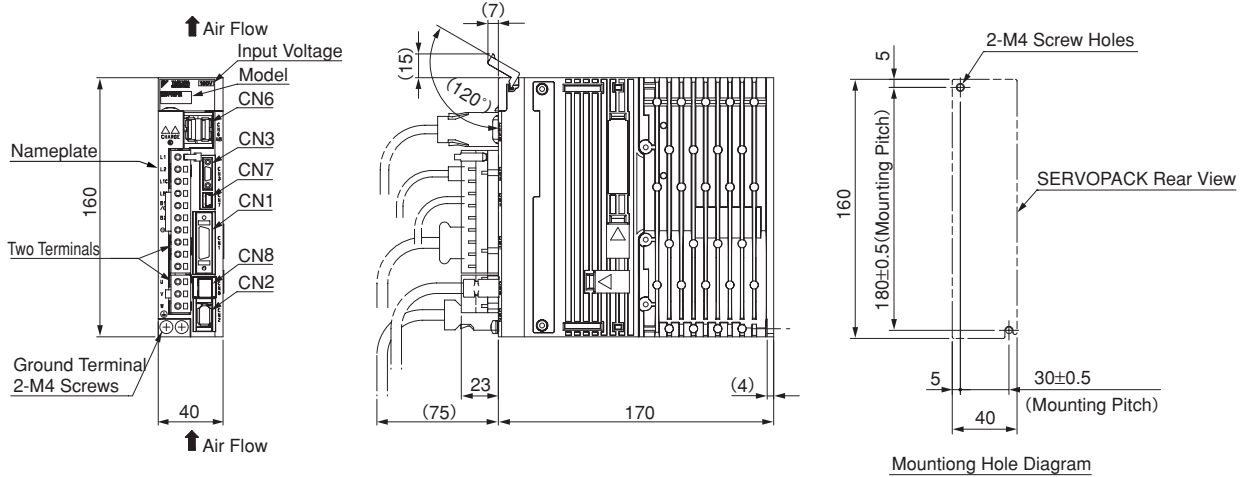

Mounting Hole Diagram

Approx. Mass: 1.0 kg

(2) Single-phase 100 VAC, Model: SGDV-2R8F1□A

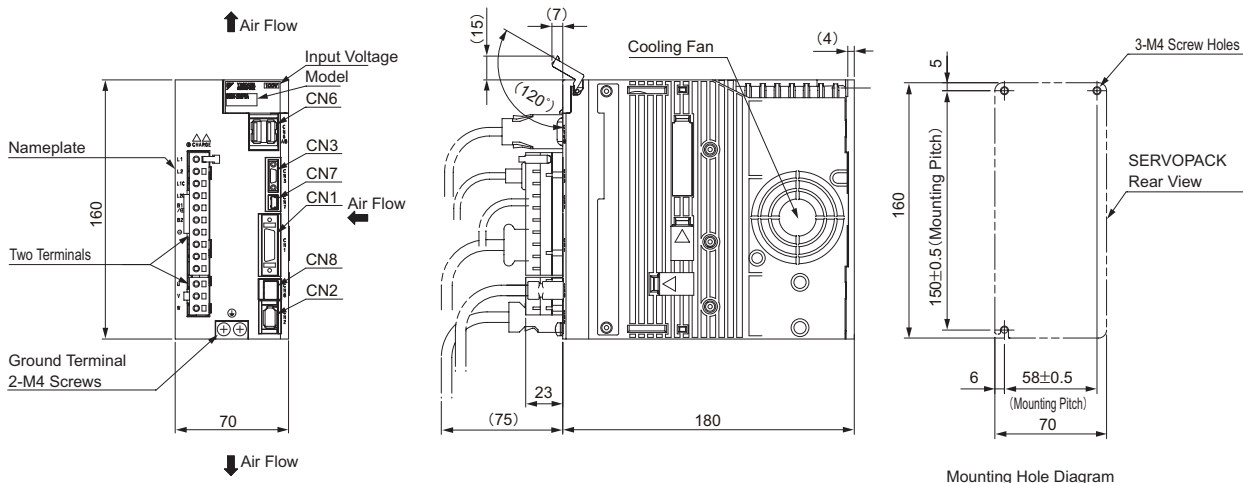

Mounting Hole Diagram

Approx. Mass: 1.5 kg

(3) Three-phase 200 VAC, Model: SGDV-R70A1□B, -R90A1□B, and -1R6A1□B

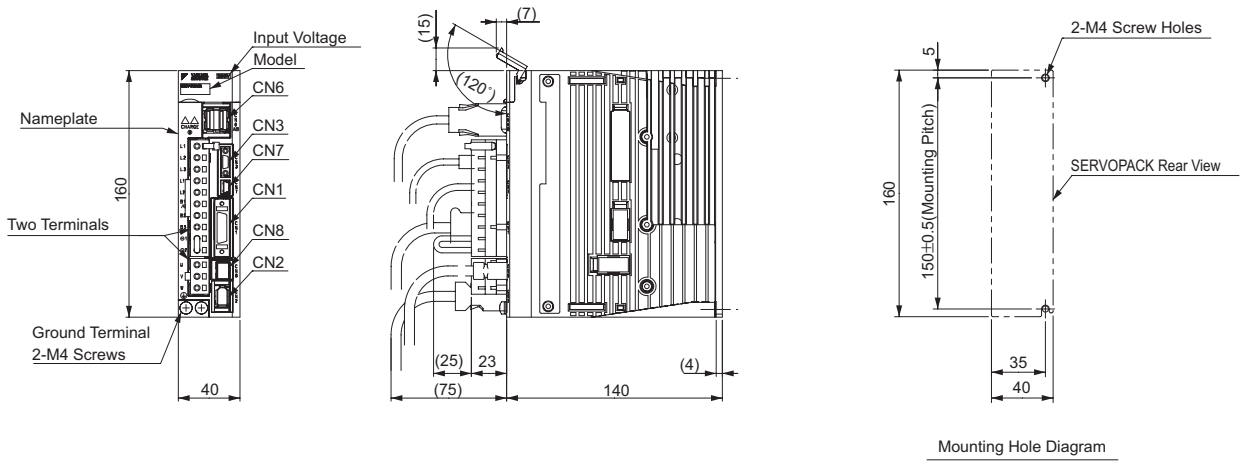

Mounting Hole Diagram

Approx. Mass: 0.9 kg



**External Dimensions** Units: mm

(4) Three-phase 200 VAC, Model: SGDV-2R8A1□B

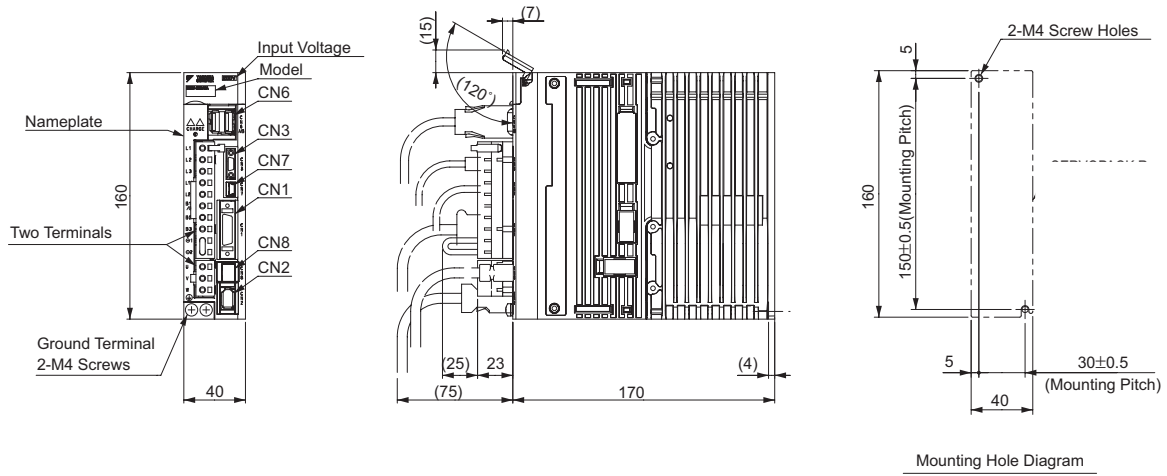

Mounting Hole Diagram

Approx. Mass: 1.0 kg

(5) Three-phase 200 VAC, Model: SGDV-3R8A1□A, -5R5A1□A, and -7R6A1□A

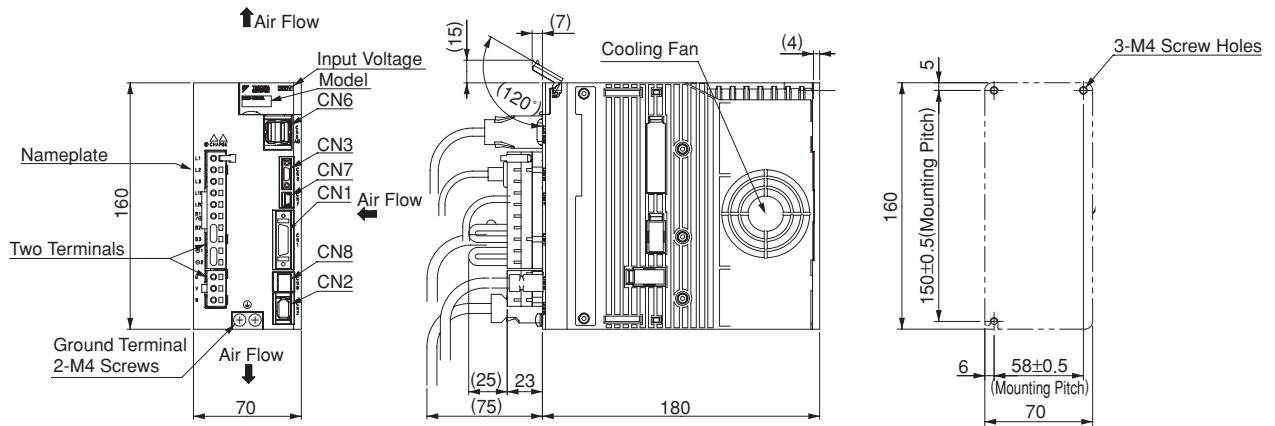

Mounting Hole Diagram

Approx. Mass: 1.5 kg

(6) Three-phase 200 VAC, Model: SGDV-120A1□A

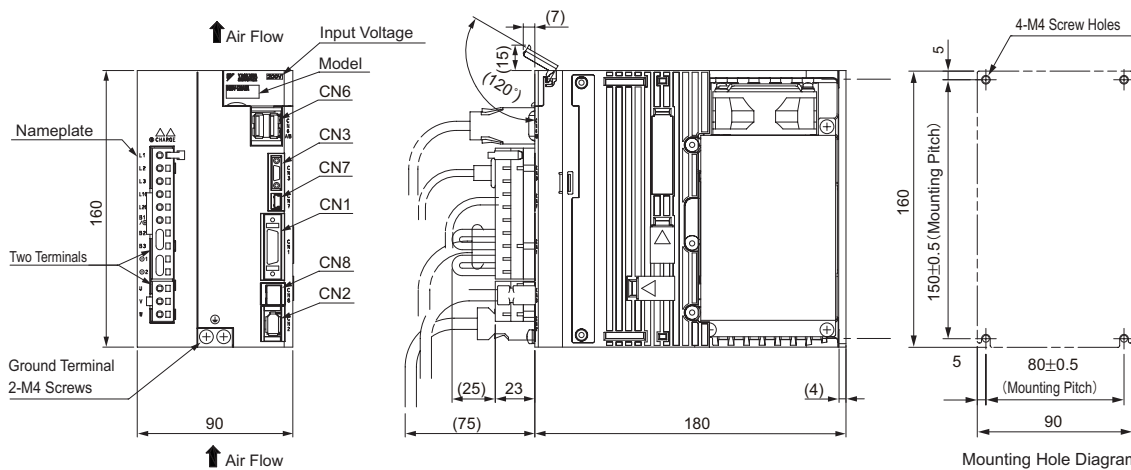

Mounting Hole Diagram

Approx. Mass: 2.4 kg

External Dimensions Units: mm

(7) Single-phase 200 VAC, Model: SGDV-120A1□A008000 (1.5 kW, single-phase input type)  
 Three-phase 200 VAC, Model: SGDV-180A1□A and -200A1□A

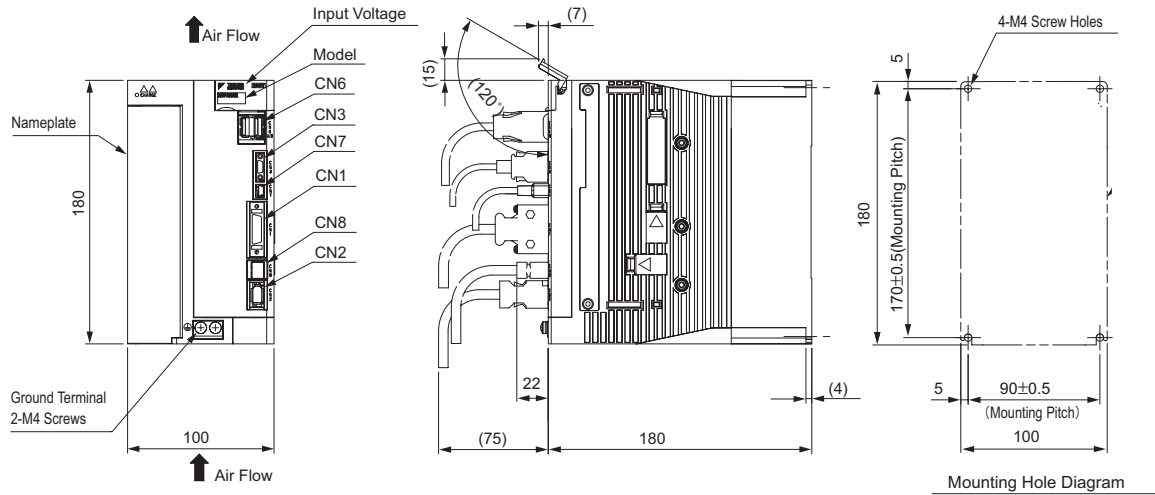

Approx. Mass: 2.8 kg

(8) Three-phase 200 VAC, Model: SGDV-330A1□A

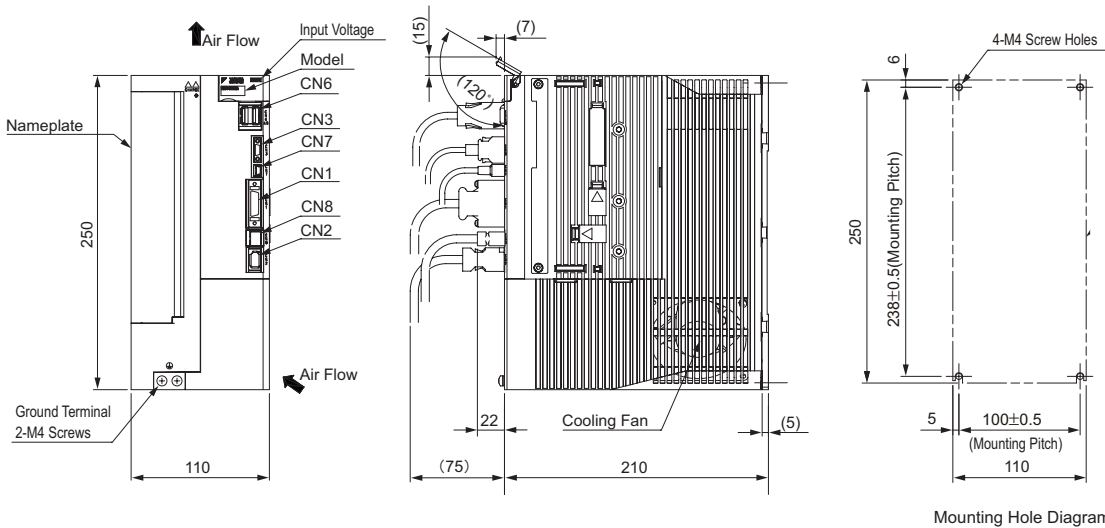

Approx. Mass: 4.6 kg

**External Dimensions** Units: mm

(9) Three-phase 200 VAC, Model: SGD V-470A1□A and -550A1□A

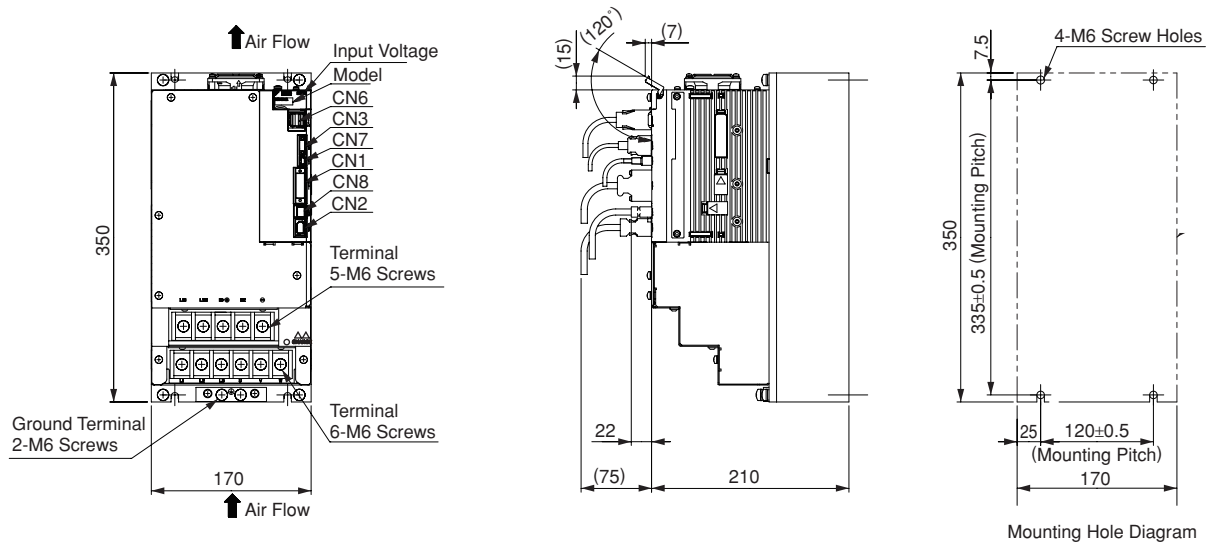

Approx. Mass: 10.2 kg

(10) Three-phase 200 VAC, Model: SGD V-590A1□A and -780A1□A

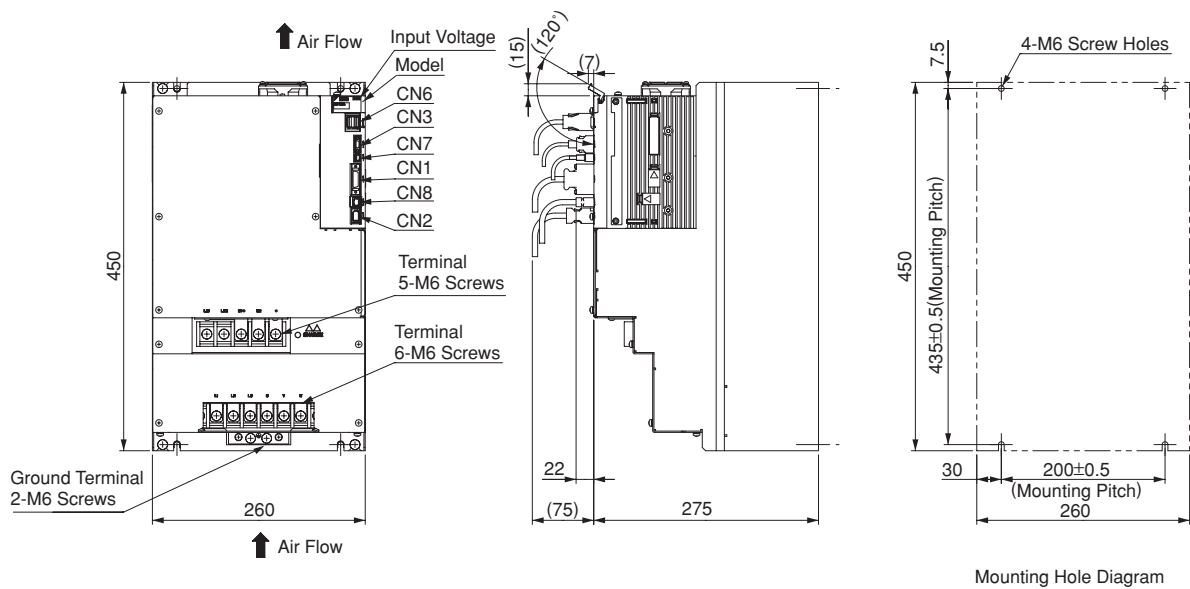

Approx. Mass: 21.0 kg

**External Dimensions** Units: mm

(11) Three-phase 400 VAC, Model: SGDV-1R9D1□A, -3R5D1□A, and -5R4D1□A

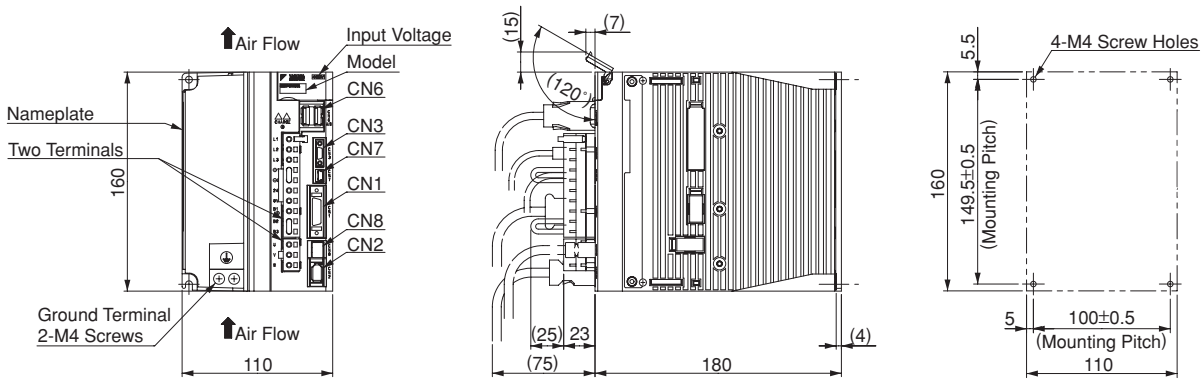

Mounting Hole Diagram

Approx. Mass: 2.7 kg

(12) Three-phase 400 VAC, Model: SGDV-8R4D1□A, and -120D1□A

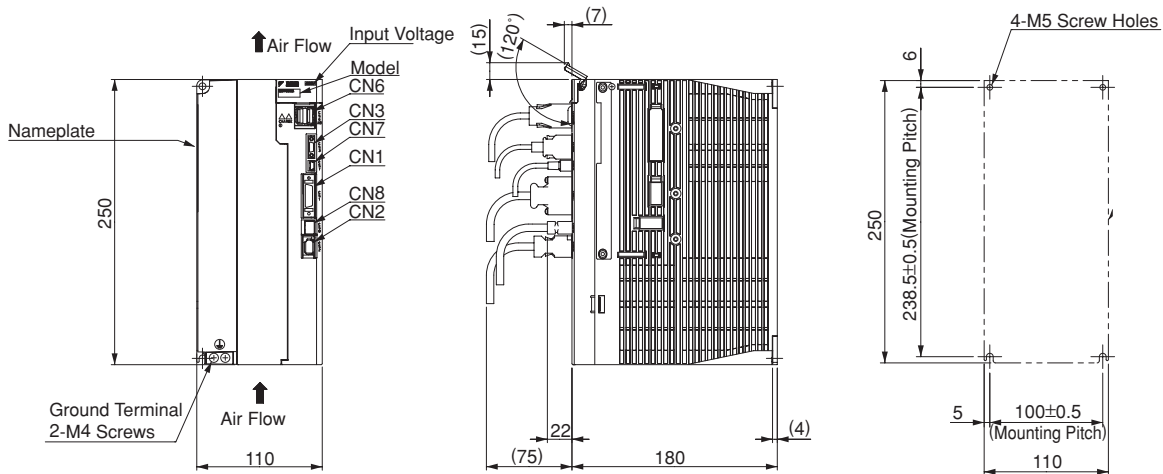

Mounting Hole Diagram

Approx. Mass: 3.7 kg

(13) Three-phase 400 VAC, Model: SGDV-170D1□A

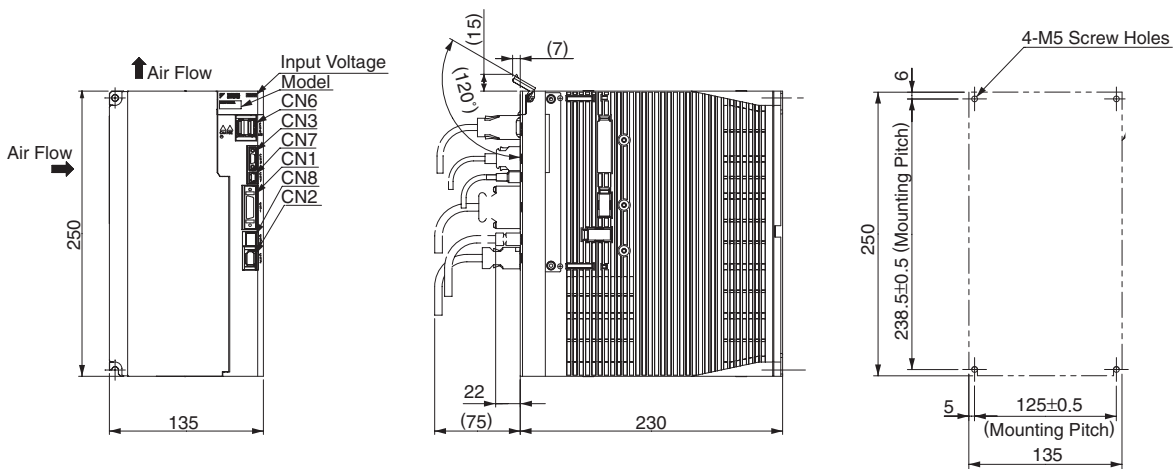

Mounting Hole Diagram

Approx. Mass: 5.6 kg

## External Dimensions Units: mm

(14) Three-phase 400 VAC, Model: SGDV-210D1□A and -260D1□A

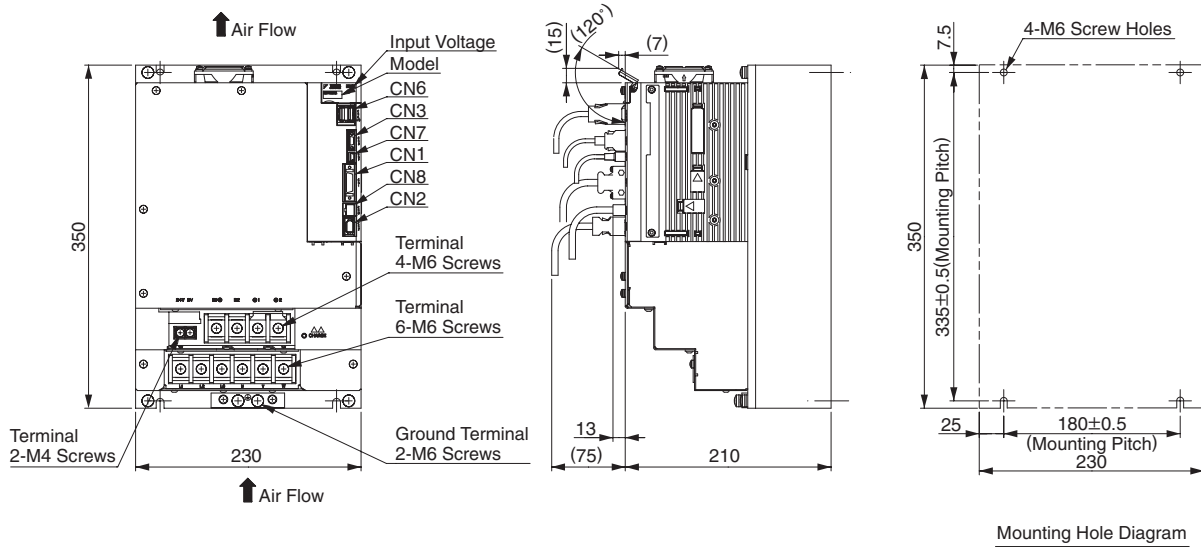

Mounting Hole Diagram

Approx. Mass: 11.3 kg

(15) Three-phase 400 VAC, Model: SGDV-280D1□A and -370D1□A

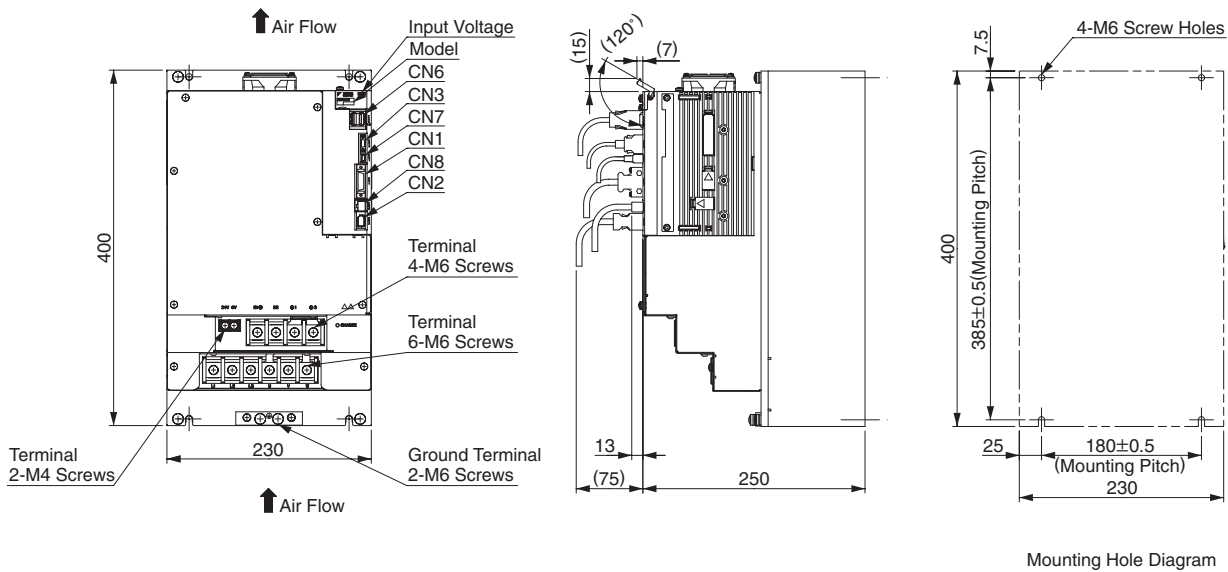

Mounting Hole Diagram

Approx. Mass: 16.2 kg

### Connectors for Base-mounted SERVOPACKS

Port	Model	Pin	Manufacturer
CN1	10226-52A2PL	26	Sumitomo 3M Ltd.
CN2	53984-0671	6	Molex Japan Co., Ltd.
CN3	HDR-EC14LFDTN-SLE-PLUS	14	Honda Tsushin Kogyo Co., Ltd.
CN6	1903815-1	8	Tyco Electronics AMP K.K.
CN7	MNC23-5K5H00	5	ADVANCED-CONNECTEK INC.
CN8	1981080-1	8	Tyco Electronics AMP K.K.

Note: The connectors above or their equivalents are used for SERVOPACKS.

External Dimensions Units: mm

● Rack-mounted SERVOPACKs (6 kW or more models: duct-ventilated)

(1) Single-phase 100 VAC, Model: SGDV-R70F1□A001, -R90F1□A001, and -2R1F1□A001

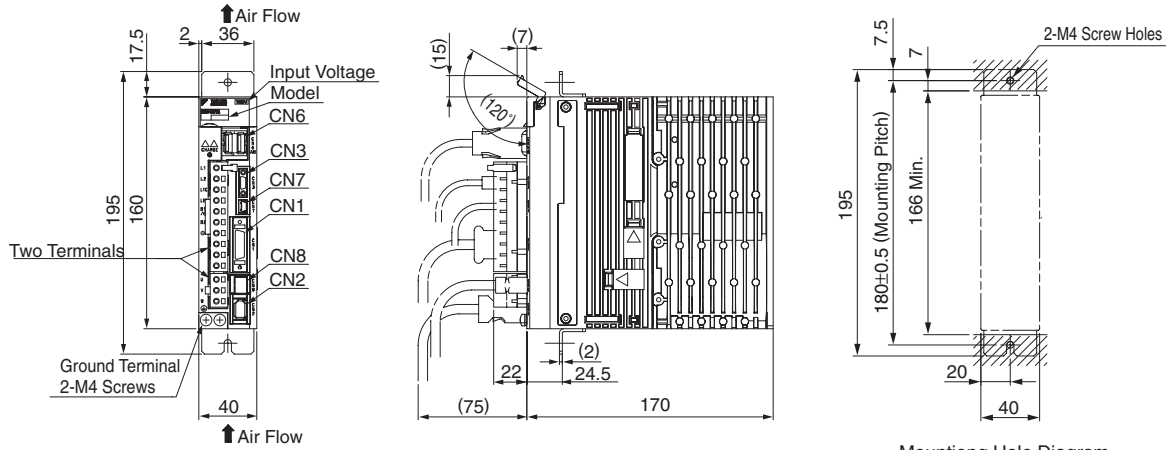

Mounting Hole Diagram

Approx. Mass: 1.1 kg

(2) Single-phase 100 VAC, Model: SGDV-2R8F1□A001

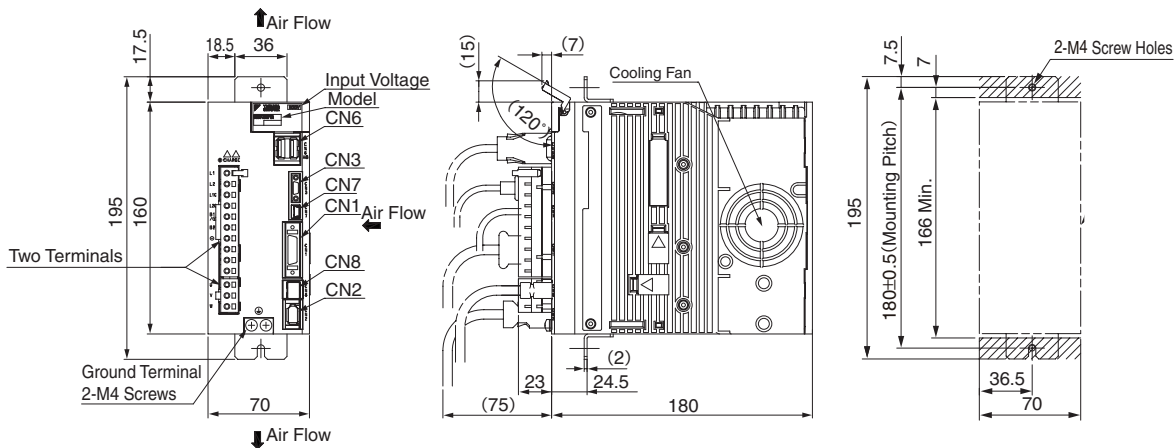

Mounting Hole Diagram

Approx. Mass: 1.5 kg

(3) Three-phase 200 VAC, Model: SGDV-R70A1□A001, -R90A1□A001, and -1R6A1□A001

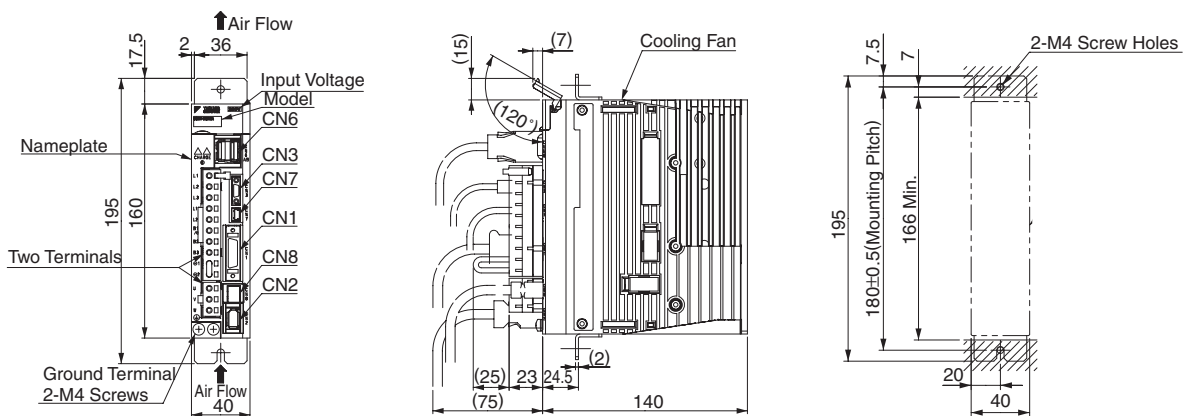

Mounting Hole Diagram

Approx. Mass: 0.9 kg

**External Dimensions** Units: mm

(4) Three-phase 200 VAC, Model: SGDV-2R8A1□A001

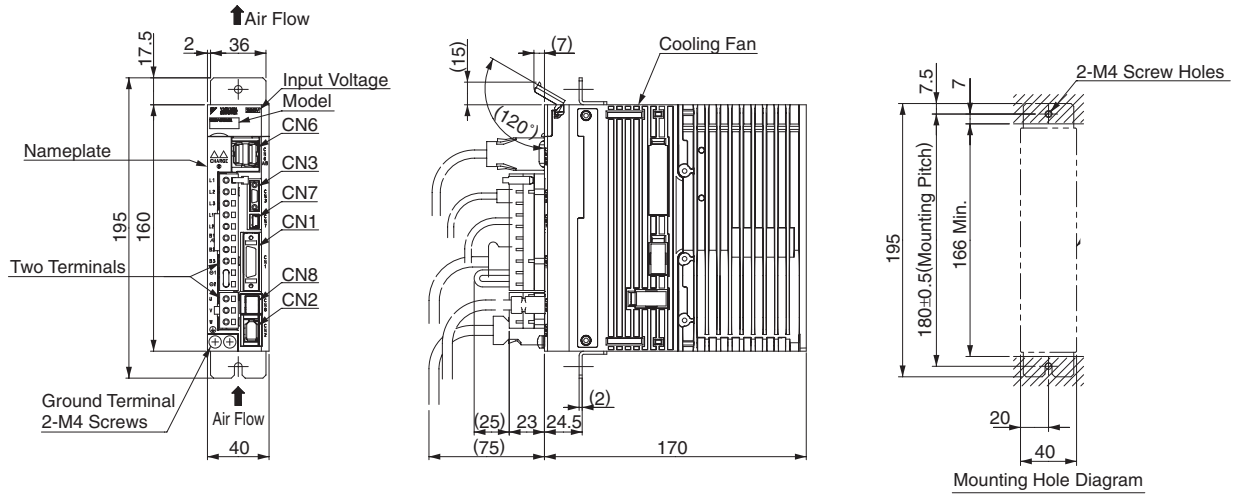

Approx. Mass: 1.0 kg

(5) Three-phase 200 VAC, model: SGDV-3R8A1□A001, -5R5A1□A001, and -7R6A1□A001

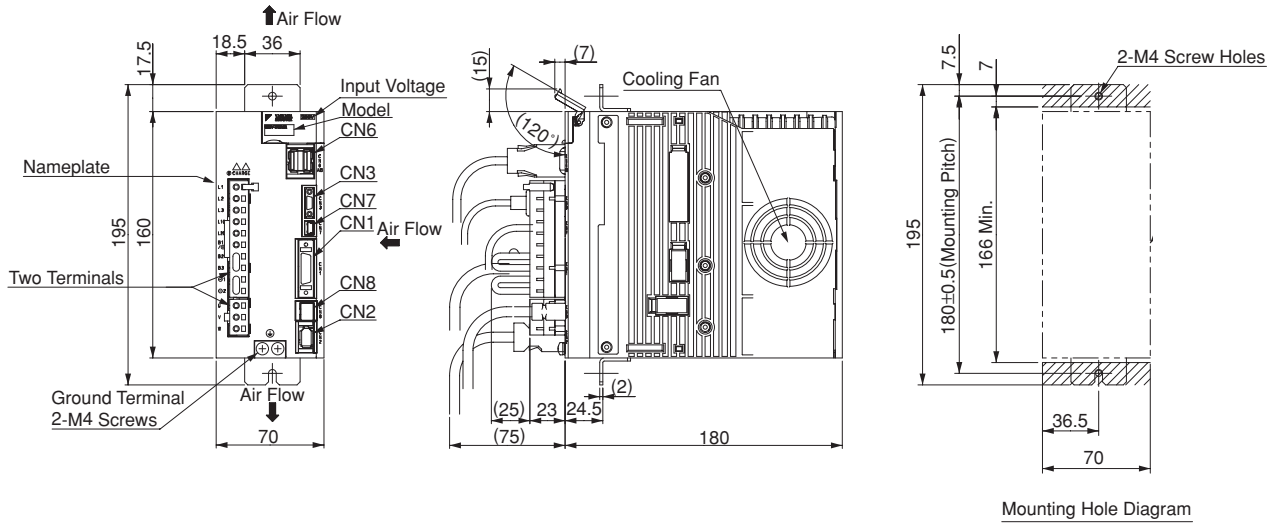

Approx. Mass: 1.5 kg

(6) Three-phase 200 VAC, Model: SGDV-120A1□A001

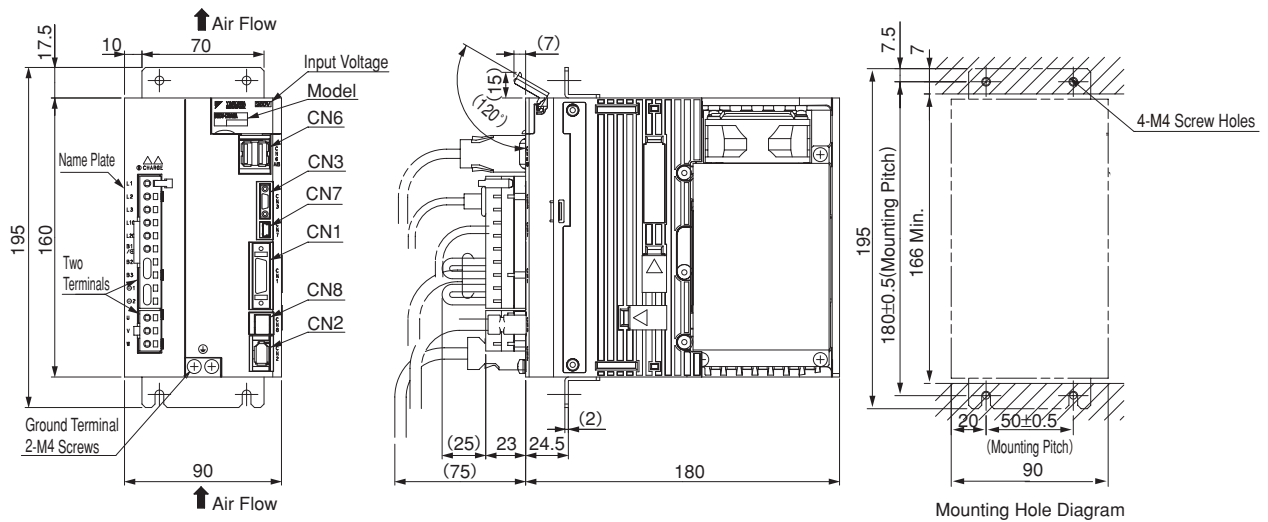

Approx. Mass: 2.5 kg

External Dimensions Units: mm

(7) Single-phase 200 VAC, Model: SGDV-120A1□A008000 (1.5 kW, single-phase input type)  
 Three-phase 200 VAC, Model: SGDV-180A1□A001 and -200A1□A001

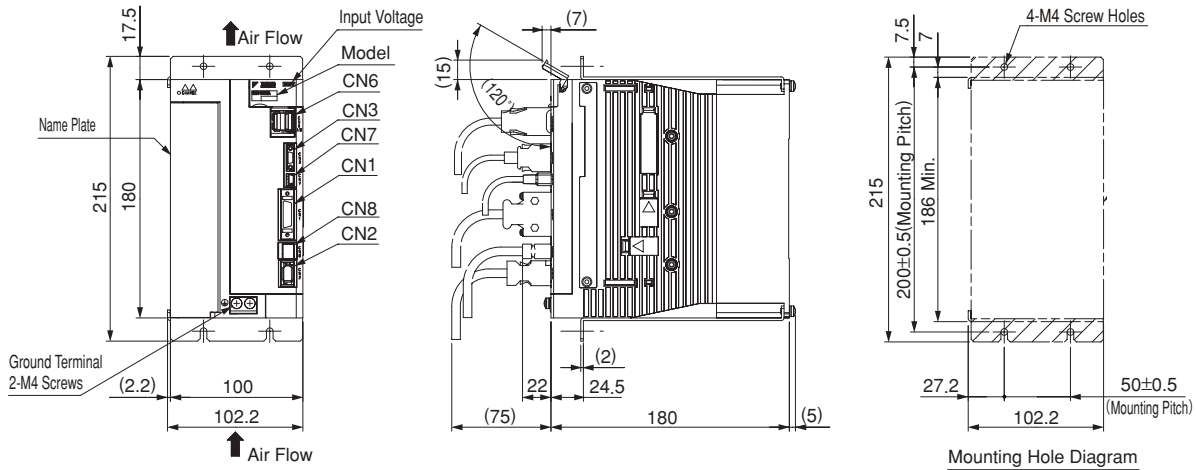

Approx. Mass: 3.1 kg

(8) Three-phase 200 VAC, Model: SGDV-330A1□A001

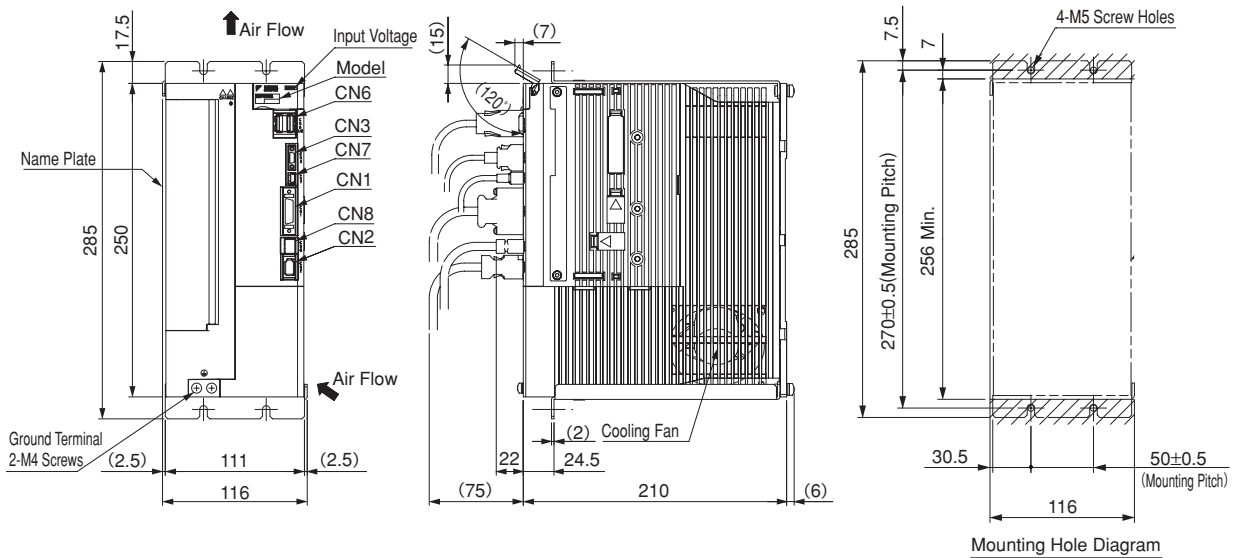

Approx. Mass: 5.0 kg



**External Dimensions** Units: mm

(9) Three-phase 200 VAC, Model: SGDV-470A1□A001 and -550A1□A001 (Duct-ventilated type)

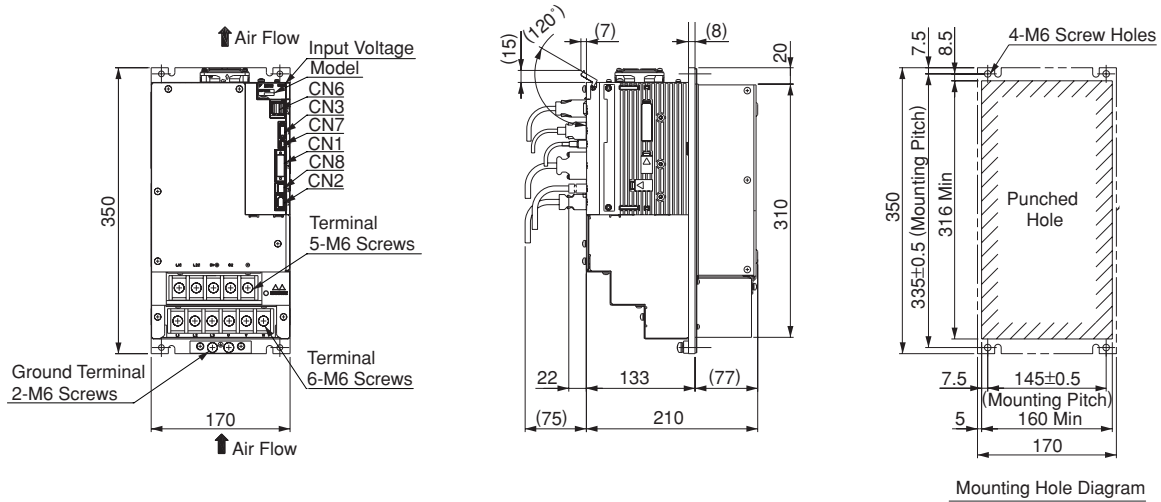

Approx. Mass: 8.5 kg

(10) Three-phase 200 VAC, Model: SGDV-580A1□A001 and -780A1□A001 (Duct-ventilated type)

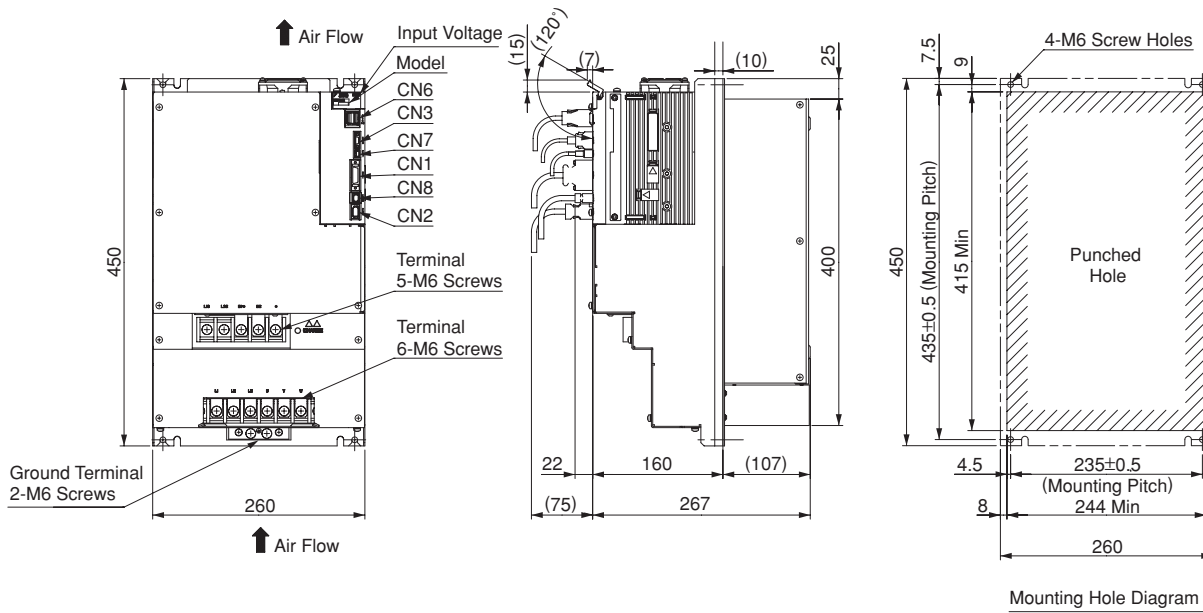

Approx. Mass: 16.0 kg

External Dimensions Units: mm

(11) Three-phase 400 VAC, Model: SGDV-1R9D1□A001, -3R5D1□A001, and -5R4D1□A001

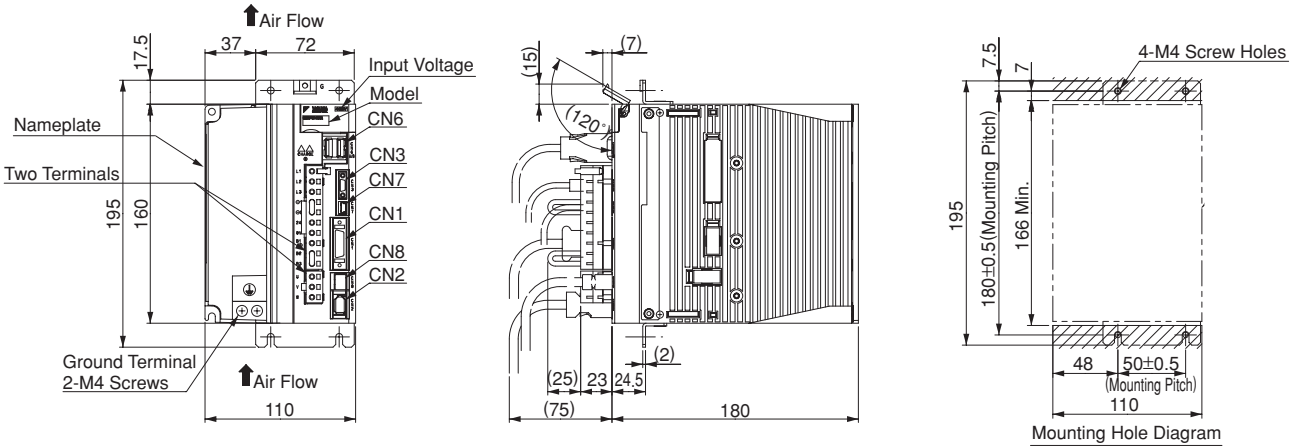

(12) Three-phase 400 VAC, Model: SGDV-8R4D1□A001 and -120D1□A001

Approx. Mass: 2.7 kg

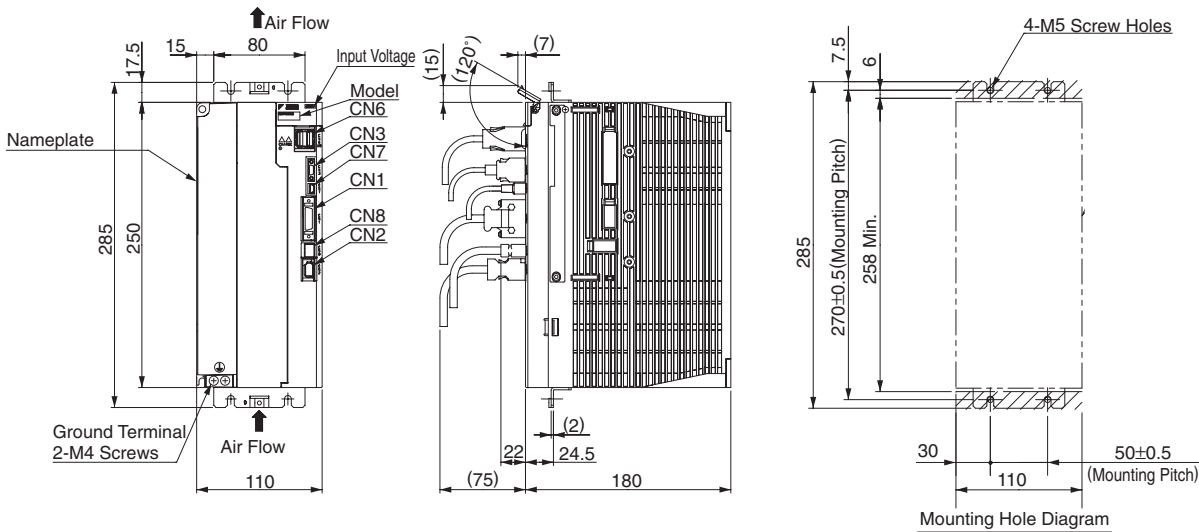

(13) Three-phase 400 VAC, Model: SGDV-170D1□A001

Approx. Mass: 3.8 kg

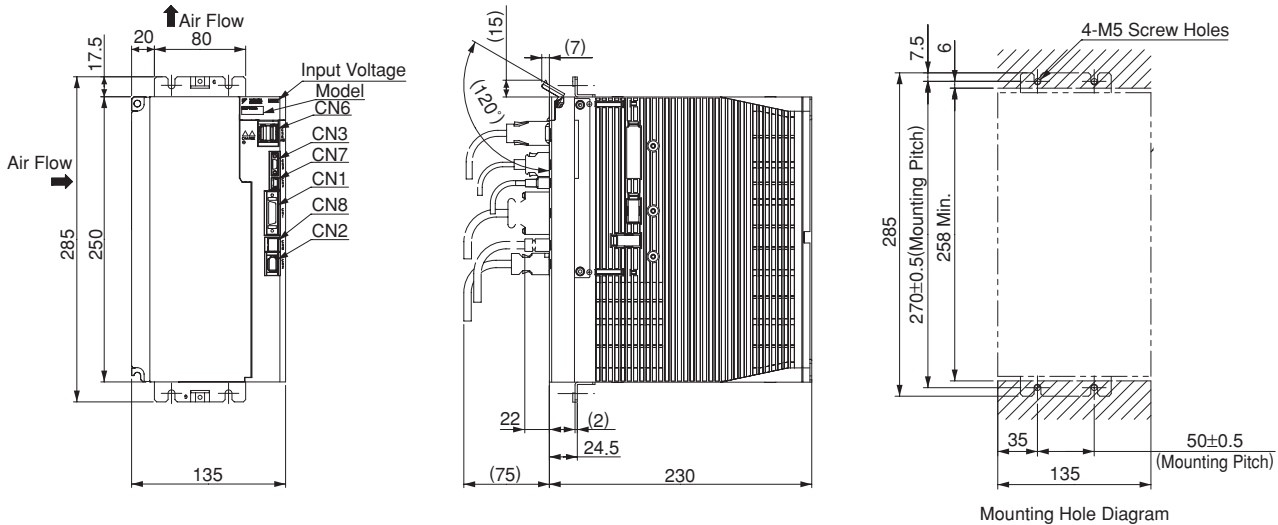

Approx. Mass: 5.7 kg

## External Dimensions Units: mm

(14) Three-phase 400 VAC, Model: SGD V-210D1□A001 and -260D1□A001 (Duct-ventilated type)

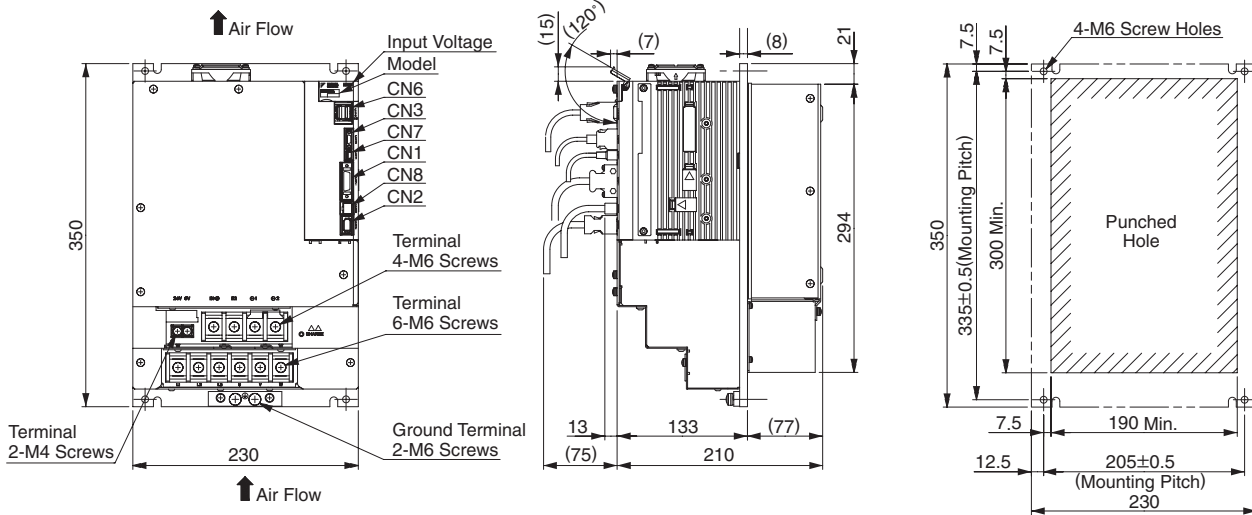

Mounting Hole Diagram

Approx. Mass: 8.1 kg

(15) Three-phase 400 VAC, Model: SGD V-280D1□A001 and -370D1□A001 (Duct-ventilated type)

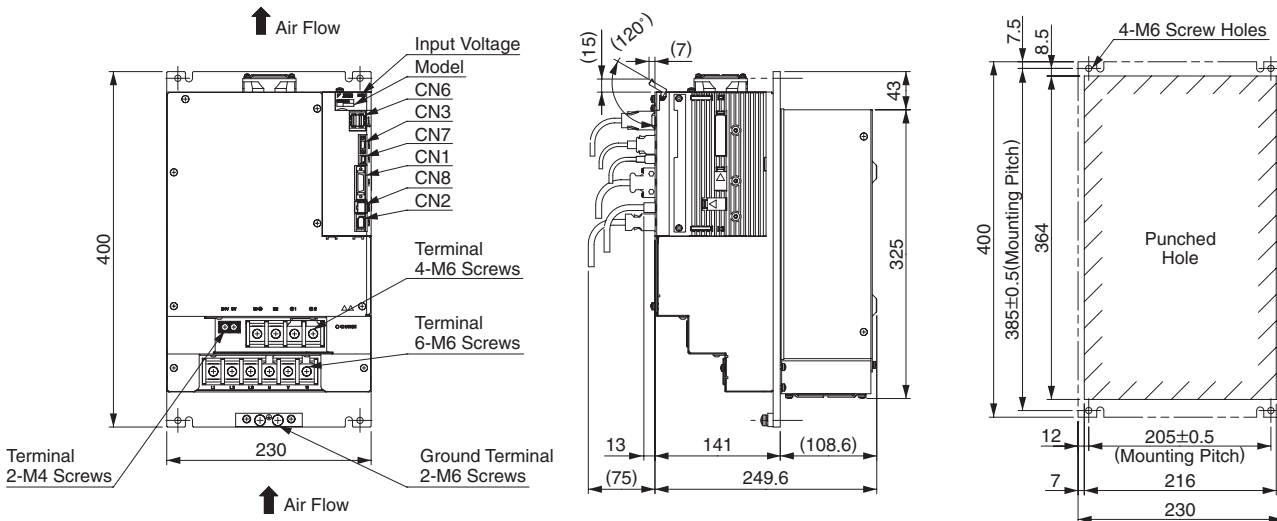

Mounting Hole Diagram

Approx. Mass: 13.6 kg

### Connectors for Rack-mounted SERVOPACKS







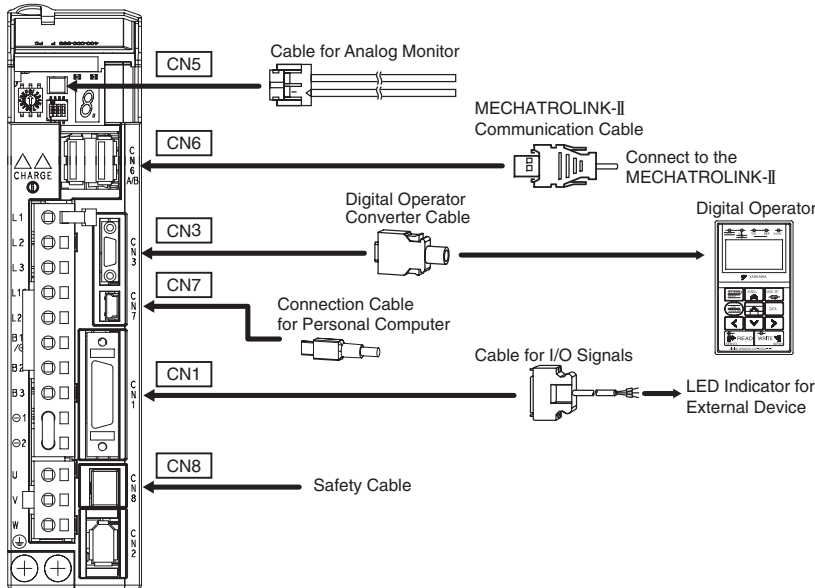

Port	Model	Pin	Manufacturer
CN1	10226-52A2PL	26	Sumitomo 3M Ltd.
CN2	53984-0671	6	Molex Japan Co., Ltd.
CN3	HDR-EC14LFD TN-SLE-PLUS	14	Honda Tsushin Kogyo Co., Ltd.
CN6	1903815-1	8	Tyco Electronics AMP K.K.
CN7	MNC23-5K5H00	5	ADVANCED-CONNECTEK INC.
CN8	1981080-1	8	Tyco Electronics AMP K.K.

Note: The connectors above or their equivalents are used for SERVOPACKS.

Selecting Cables

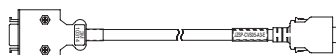
● Cables for **CN1** **CN3** **CN5** **CN6** **CN7** **CN8** (MECHATROLINK-II Communications Reference Type SERVOPACKs)

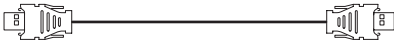

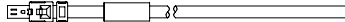
Name	Length	Order No.	Specifications	Details	
<b>CN1</b> Cables for I/O Signals	Connector Kit	JZSP-CSI9-2-E	Soldered 	(1)	
	Connector Terminal Converter Unit	0.5 m	SBK-U-VBA-A5	Terminal Block and 0.5 m Connection Cable 	(2)
		1 m	SBK-U-VBA-01		
		3 m	SBK-U-VBA-03		
	Cable with Loose wire at One End	1 m	JZSP-CSI02-1-E		(3)
		2 m	JZSP-CSI02-2-E		
3 m		JZSP-CSI02-3-E			
<b>CN3</b>	Digital Operator	JUSP-OP05A-1-E	With Connection Cable (1 m) 	(4)	
	Digital Operator Converter Cable <sup>1</sup>	0.3 m	Cable with Connectors at Both Ends 	(5)	
<b>CN7</b> Connection Cables for Personal Computer	2.5 m	JZSP-CVS06-02-E	Cable with Connectors at Both Ends 	(9)	
<b>CN6A</b> <b>CN6B</b> MECHATROLINK-II Communication Cable	Cables with Connectors at Both Ends	0.5 m	JEPMC-W6002-A5-E		(7)
		1 m	JEPMC-W6002-01-E		
	—	JEPMC-W6002-□□-E			
<b>CN5</b> Cables for Analog Monitor	Terminator	JEPMC-W6022-E		(8)	
	Cables with Connector <sup>2</sup>	1 m	JZSP-CA01-E	SERVOPACK End 	(6)
<b>CN8</b> Cables for Safety Functions	Cables with Connector <sup>2</sup>	3 m	JZSP-CVH03-03-E		(10)
	Connector kit <sup>3</sup>	Contact Tyco Electronics AMP K.K. Product name : Industrial Mini I/O D-shape Type1 Plug Connector Kit Model : 2013595-1			

\*1 : A converter cable is required to use  $\Sigma$ -III series digital operators (model: JUSP-OP05A) for  $\Sigma$ -V series SERVOPACKs.

\*2 : When using the safety function, connect this cable to the safety devices.

Even when not using the safety function, use SERVOPACKs with the Safe Jumper Connector (model: JZSP-CVH05-E) connected.

\*3 : Use the connector kit when you make cables yourself.

## Selecting Cables Units: mm

### (1) Connector Kit for CN1

Use the following connector and cable to assemble the cable. The CN1 connector kit includes one case and one connector.

Connector Kit Model	Case		Connector	
	Model	Qty	Model	Qty
JZSP-CSI9-2-E	10326-52A0-008*	1 set	10126-3000PE* (Soldered)	1

\*: Manufactured by Sumitomo 3M Ltd.

#### · Cable Size

Item	Specifications
Cable	Use twisted-pair or twisted-pair shielded wire.
Applicable Wires	AWG24, 26, 28, 30
Cable Finished Diameter	16 dia. max.

#### · Dimensional Drawings of Case

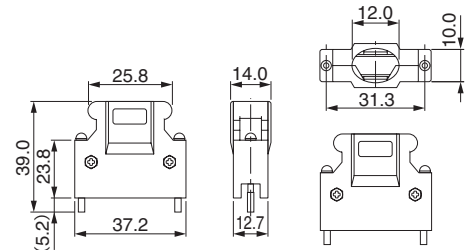

#### · Dimensional Drawings of Connector

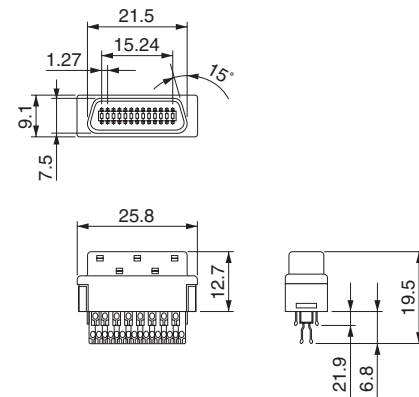

### (2) Connector Terminal Converter Unit for CN1 (SBK-U-VBA-xx)

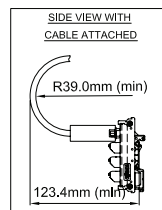
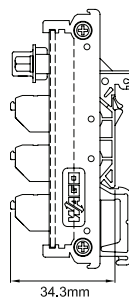
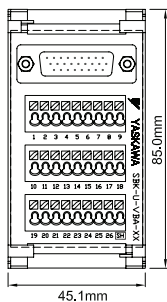
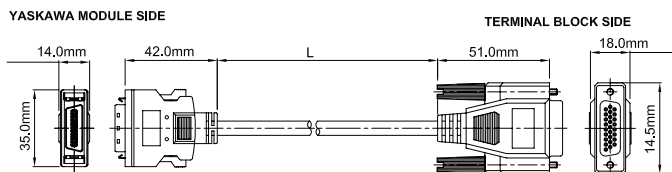

CABLE SPECIFICATION (mm)	
OUTER DIAMETER	6.5 +/- 0.2mm
BENDING RADIUS	6 x O.D. MINIMUM 15 x O.D. FOR LONG TERM RELIABILITY

ITEM#	L = LENGTH (mm)
SBK-U-VBA-A5	500 +/- 38.1
SBK-U-VBA-01	1000 +/- 38.1
SBK-U-VBA-03	3000 +/- 38.1

#### SBK-U-VBA-xx Function Chart for SGD Servo Amplifier

Pin No.	SGDV Mechatrolink-II type / SGD Option type	
	Signal	Function
1	/BK+ (/SO1+)	Brake interlock output (+) (General purpose output 1 (+))
2	/BK- (/SO1-)	Brake interlock output (-) (General purpose output 1 (-))
3	ALM+	Servo alarm output (+)
4	ALM-	Servo alarm output (-)
5	-	
6	+24VIN	Control power supply for sequence signal input
7	P-OT (/SI1)	Forward run prohibited input (General purpose input 1)
8	N-OT (/SI2)	Reverse run prohibited input (General purpose input 2)
9	/DEC (/SI3)	Zero-point return deceleration switch input (General purpose input 3)
10	/EXT1 (/SI4)	External latch signal 1 input (General purpose input 4)
11	/EXT2 (/SI5)	External latch signal 2 input (General purpose input 5)
12	/EXT3 (/SI6)	External latch signal 3 input (General purpose input 6)
13	/SI0	General purpose input 0
14	BAT (+)	Battery (+) input
15	BAT (-)	Battery (-) input
16	SG	Signal ground
17	PAO	Phase-A pulse output (+)
18	/PAO	Phase-A pulse output (-)
19	PBO	Phase-B pulse output (+)
20	/PBO	Phase-B pulse output (-)
21	PCO	Phase-C pulse output (+)
22	/PCO	Phase-C pulse output (-)
23	/SO2+	General purpose output 2 (+)
24	/SO2-	General purpose output 2 (-)
25	/SO3+	General purpose output 3 (+)
26	/SO3-	General purpose output 3 (-)

Note: General purpose input and output signals are shown with their default signals assigned - signal assignment may have been changed by parameter

Selecting Cables Units: mm

(3) Cable with Loose Wires at One End for CN1  
Dimensional Drawings of Cable

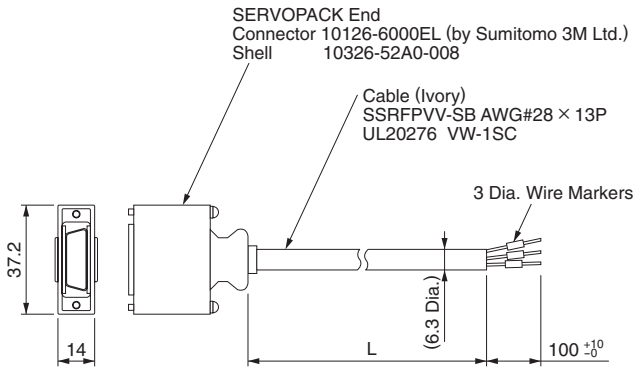

Model	Cable Length
JZSP-CSI02-1-E	1 m
JZSP-CSI02-2-E	2 m
JZSP-CSI02-3-E	3 m

● Cable with Loose Wires at One End for CN1  
Connection Diagram of JZSP-CSI02-□-E Cable

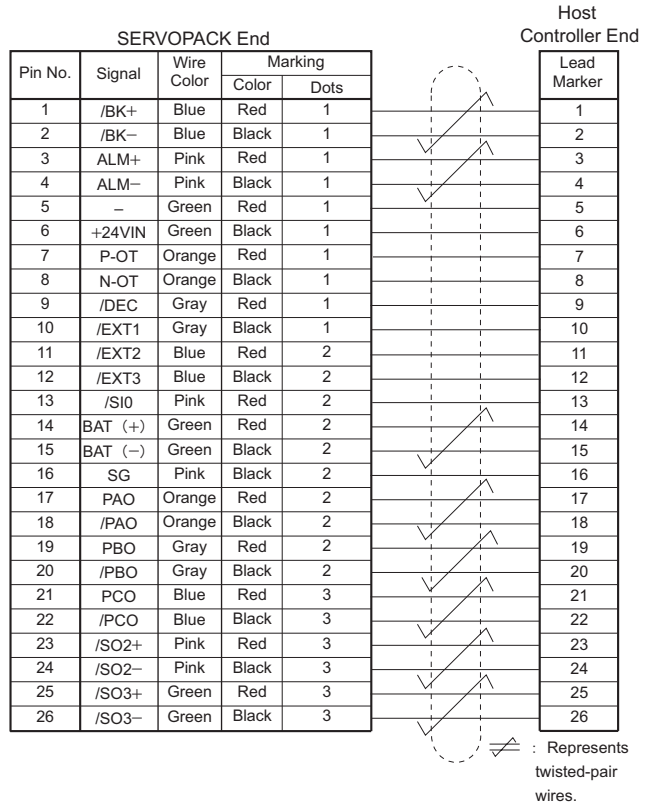

(4) Digital Operator (Model: JZSP-OP05A-1-E)

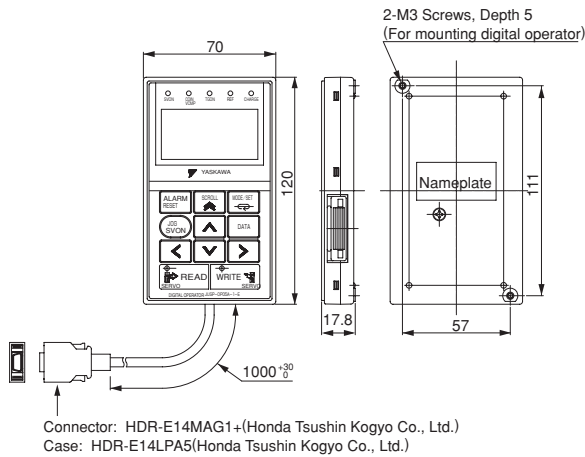

(5) Digital Operator Converter Cable for CN3

(Model: JZSP-CVS05-A3-E)

A converter cable is required to use  $\Sigma$ -III series digital operators (model: JZSP-OP05A) for  $\Sigma$ -V series SERVOPACKS.

· Dimensional Drawings

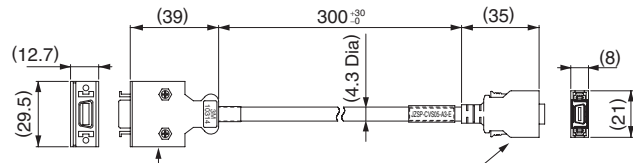

Connector (14-pole): 10214-6202PL (Sumitomo 3M Ltd.)

Cover: FA458036 (Yasco Components Co., Ltd.)

Connector (14-pole): HDR-E14MAG1+ (Honda Tsushin Kogyo Co., Ltd.)

Cover: HDR-E14LPA5 (Honda Tsushin Kogyo Co., Ltd.)

## Selecting Cables Units: mm

### (6) Cable for Analog Monitor for CN5 (Model: JZSP-CA01-E)

· Dimensional Drawings

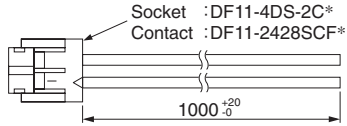

\* : Manufactured by Hirose Electric Corporation.

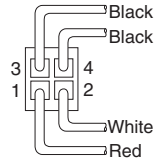

View from Cable End

· Specifications

Pin No.	Cable Color	Signal	Standard Settings
1	Red	Analog Monitor 2	Motor speed : 1V/1000 min <sup>-1</sup>
2	White	Analog Monitor 1	Torque reference : 1V/100% rated torque
3, 4	Black (2 cables)	GND(0V)	-

Note : The specifications above are factory settings. Monitor specifications can be changed by changing parameters Pn006 and Pn007.

### (7) MECHATROLINK-II Communications Cable for CN6 (Model: JEPMC-W6002-□□-E)

· Dimensional Drawings

① Cable with Connectors at Both Ends



Model	Cable Length(L)
JEPMC-W6002-A5-E	0.5 m
JEPMC-W6002-01-E	1.0 m
JEPMC-W6002-03-E	3.0 m
JEPMC-W6002-05-E	5.0 m
JEPMC-W6002-10-E	10.0 m
JEPMC-W6002-20-E	20.0 m
JEPMC-W6002-30-E	30.0 m
JEPMC-W6002-40-E	40.0 m
JEPMC-W6002-50-E	50.0 m

② Cable with Ferrite Core

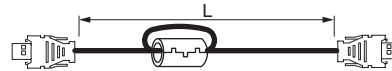

Model	Cable Length (L)
JEPMC-W6003-A5-E	0.5 m
JEPMC-W6003-01-E	1.0 m
JEPMC-W6003-03-E	3.0 m
JEPMC-W6003-05-E	5.0 m
JEPMC-W6003-10-E	10.0 m
JEPMC-W6003-20-E	20.0 m
JEPMC-W6003-30-E	30.0 m
JEPMC-W6003-40-E	40.0 m
JEPMC-W6003-50-E	50.0 m

**IMPORTANT**

Use a MECHATROLINK-II communications cable specified by Yaskawa. When using other cables, noise resistance may be reduced, and operation cannot be guaranteed.

### (8) MECHATROLINK-II Terminator for CN6 (Model : JEPMC-W6022-E)

· Dimensional Drawings

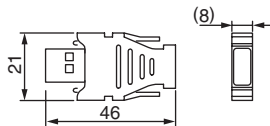

Selecting Cables Units: mm

(9) Connection Cable for Personal Computer for CN7  
 (Model: JZSP-CVS06-02-E)

· Dimensional Drawings

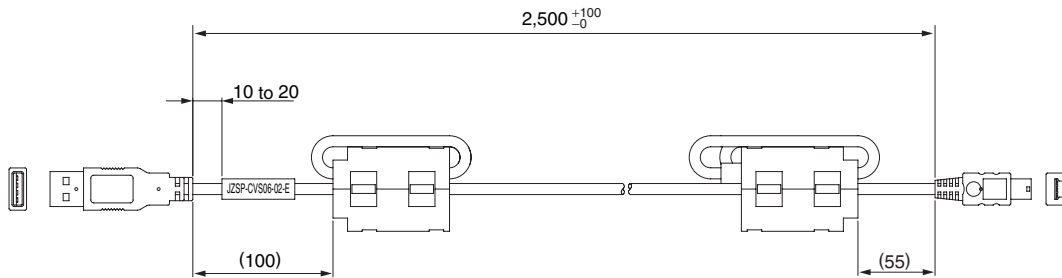

**IMPORTANT** Use a cable specified by Yaskawa.  
 When using other cables, operation cannot be guaranteed.

(10) Cable with Connector for CN8  
 (Model: JZSP-CVH03-03-E)

· Dimensional Drawings

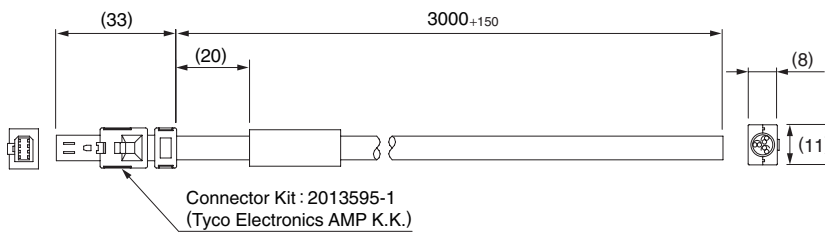

· Specifications

Pin No.	Signal	Lead Color	Marking Color
1	Not used	-	-
2	Not used	-	-
3	/HWBB1-	White	Black
4	/HWBB1+	White	Red
5	/HWBB2-	Gray	Black
6	/HWBB2+	Gray	Red
7	EDM1-	Orange	Black
8	EDM1+	Orange	Red



# MECHATROLINK-III Communications Reference Type SERVOPACKs

## SGDV-□□□□21

(For Rotary Servomotors)

## SGDV-□□□□25

(For Linear Servomotors)



### Model Designations

SGDV - R70 A 01 B 002000

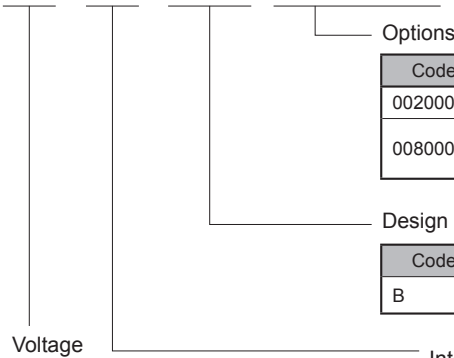
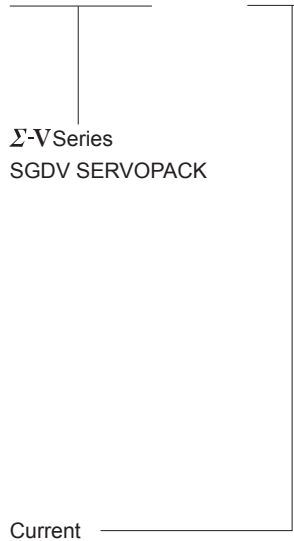

Code	Specifications
002000	Base-mounted, varnish(standard)
008000	Single-phase, 200VAC Input (model: SGD-120A01A008000)

Code	Specifications
B	Standard

Code	Specifications
F	100 VAC
A	200 VAC
D	400 VAC

Code	Specifications
21	MECHATROLINK-III communications Reference Type (for rotary servomotors)
25	MECHATROLINK-III communications Reference Type (for linear servomotors)

Code	100 V (Single Phase)		Code	200 V (Three Phase)		Code	400 V (Three Phase)	
	Applicable Servomotor Max. Capacity kW			Applicable Servomotor Max. Capacity kW			Applicable Servomotor Max. Capacity kW	
R70	0.05		R70*	0.05		1R9	0.5	
R90	0.1		R90*	0.1		3R5	1.0	
2R1	0.2		1R6*	0.2		5R4	1.5	
2R8	0.4		2R8*	0.4		8R4	2.0	
			3R8	0.5		120	3.0	
			5R5*	0.75		170	5.0	
			7R6	1.0		210	6.0	
			120**	1.5		260	7.5	
			180	2.0		280	11	
			200	3.0		370	15	
			330	5.0				
			470	6.0				
			550	7.5				
			590	11				
			780	15				

NOTE: Shaded items are non-stock.

\* These amplifiers can be powered with single or three-phase.

\*\* SGD-120A□1A008000, a special version of the 1.5kW amplifier can be used for single-phase operation.

## Features

- **Real-time communications**

MECHATROLINK-III communications enable high-speed control for 62 stations at a transmission speed of 100 Mbps in a transmission cycle from 125  $\mu$ s to 4 ms (user setting). Such a high transmission speed allows real-time transmission of various data required for control.

- **Cost savings**

The 62 stations can be connected to a single MECHATROLINK-III transmission line, so wiring costs and time are greatly reduced. Also, only one signal connector is required on the host controller. And, the all-digital network eliminates the need for conversion from digital to analog for speed/torque references and for a pulse generator to generate position references.

- **High-precision motion control**

The SGD V SERVOPACK when connected to the host controller in the MECHATROLINK-III network provides not only torque, position, and speed control but also synchronized phase control that requires advanced control technology. The control mode can be changed online so that the machine can move smoothly in complex motions with great efficiency.

## Ratings

### Single-phase 100 V

SERVOPACK Model: SGD V-□□□□		R70F	R90F	2R1F	2R8F
Applicable Servomotor Max. Capacity	kW	0.05	0.1	0.2	0.4
Continuous Output Current	Arms	0.66	0.91	2.1	2.8
Max. Output Current	Arms	2.1	2.9	6.5	9.3
Main Circuit	Single-phase 100 to 115 VAC+10% to -15% 50/60 Hz				
Control Circuit	Single-phase 100 to 115 VAC+10% to -15% 50/60 Hz				

### Three-phase 200 V

SERVOPACK Model: SGD V-□□□□		R70A	R90A	1R6A	2R8A	3R8A	5R5A	7R6A	120A	180A	200A	330A	470A	550A	590A	780A
Applicable Servomotor Max. Capacity	kW	0.05	0.1	0.2	0.4	0.5	0.75	1.0	1.5	2.0	3.0	5.0	6	7.5	11	15
Continuous Output Current	Arms	0.66	0.91	1.6	2.8	3.8	5.5	7.6	11.6	18.5	19.6	32.9	46.9	54.7	58.6	78
Max. Output Current	Arms	2.1	2.9	5.8	9.3	11	16.9	17	28	42	56	84	110	130	140	170
Main Circuit	Three-phase 200 to 230 VAC+10% to -15% 50/60 Hz															
Control Circuit	Single-phase 200 to 230 VAC+10% to -15% 50/60 Hz															

### Three-phase 400 V

SERVOPACK Model: SGD V-□□□□		1R9D	3R5D	5R4D	8R4D	120D	170D	210D	260D	280D	370D
Applicable Servomotor Max. Capacity	kW	0.5	1.0	1.5	2.0	3.0	5.0	6	7.5	11	15
Continuous Output Current	Arms	1.9	3.5	5.4	8.4	11.9	16.5	20.8	25.4	28.1	37.2
Max. Output Current	Arms	5.5	8.5	14	20	28	42	55	65	70	85
Main Circuit	Three-phase 380 to 480 VAC+10% to -15% 50/60 Hz										
Control Circuit	24 VDC $\pm$ 15%										

- **SERVOPACK Overload Characteristics**

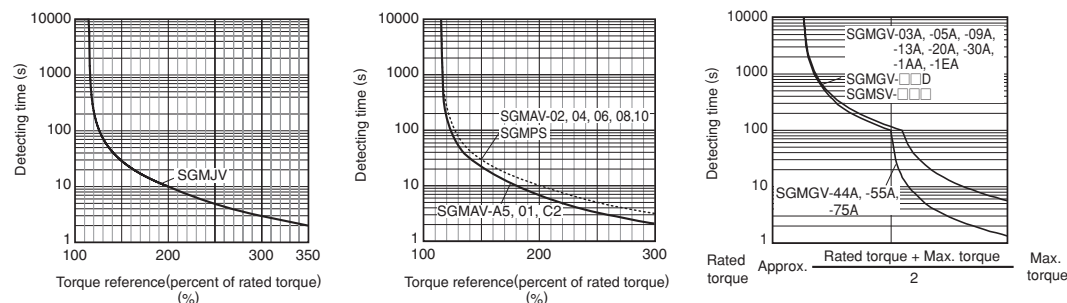

Note: Overload characteristics shown above do not guarantee continuous duty of 100% or more output. Use a servomotor with effective torque within the continuous duty zone of Torque-Motor Speed Characteristics.

## Specifications

Items		Specifications	
Control Method		IGBT PWM control, sine-wave driven	
Feedback	Rotary Servomotors	Serial encoder: 13-bit (incremental encoder) : 17-bit (incremental/absolute encoder) : 20-bit (incremental/absolute encoder)	
	With Linear Servomotors	Serial converter unit or linear scale	
Operating Conditions	Surrounding Air/Storage Temperature	Surrounding air temperature: 0 to +55°C, Storage temperature: -20 to +85°C	
	Ambient/Storage Humidity	90%RH or less (no condensation)	
	Vibration/Shock Resistance	Vibration resistance: 4.9 m/s <sup>2</sup> , Shock resistance: 19.6 m/s <sup>2</sup>	
	Protection Class/Pollution Degree	Protection class: IP10, pollution degree: 2 Do not use SERVOPACKs in the following locations: • Locations subject to corrosive or flammable gasses • Locations subject to exposure to water, oil, or chemicals • Locations subject to dust, including iron dust, and salts	
	Others	Do not use SERVOPACKs in the following locations: • Locations subject to static electricity noise, strong electromagnetic/magnetic fields, radioactivity	
	Altitude	1000 m or less	
Applicable Standards (Pending)		UL508C EN50178, EN55011/A2 group1 classA, EN61000-6-2, EN61800-3, EN61800-5-1, EN954-1, IEC61508-1 to 4	
Configuration		Standard: Base-mounted Optional: Rack-mounted, Duct-ventilated	
Performance	Speed Control Range	1:5000 (The lowest speed of the speed control range is the speed at which the servomotor will not stop with a rated torque load.)	
	Speed Regulation <sup>*1</sup>	Load Fluctuation	0% to 100% load: ±0.01% max. (at rated speed)
		Voltage Fluctuation	Rated voltage: ±10% : 0% (at rated speed)
		Temperature Fluctuation	25±25°C : ±0.1% max. (at rated speed)
	Torque Control Tolerance (Repeatability)	±1%	
Soft Start Time Setting	0 to 10 s (can be set individually for acceleration and deceleration.)		
Communications	RS-422A Communications	Interface	Digital operator (JUSP-OP05A-1-E), personal computer (can be connected with SigmaWin+)
		1:N communications	RS-422A port: N= 15 max. available
		Axis address setting	Set by parameters
	USB Communications	Interface	Personal computer (can be connected with SigmaWin+.)
	Communications Standard	Compliant with USB1.1 standard (12 Mbps)	
Display		CHARGE indicator	
Analog Monitor		Number of points: 2 Output voltage: ±10 VDC (linearity effective range ±8 V) Resolution: 16 bit Accuracy: ±20 mV (Typ) Max. output current: ±10 mA Settling time (±1%): 1.2 ms (Typ)	
Dynamic Brake (DB)		Activated when a servo alarm or overtravelling (OT) occurs, or when the power supply for the main circuit or servomotor is OFF.	
Protective Functions		Overcurrent, Overvoltage, low voltage, overload, regeneration error, etc.	
Utility Functions		Gain adjustment, alarm history, JOG operation, origin search, etc.	
Regenerative Processing		100 VAC model: External regenerative resistor (optional) 200 VAC SGDV-R70A, -R90A, -1R6A, -2R8A: External regenerative resistor (optional) 200 VAC SGDV-470A, -550A, -590A, -780A: External regenerative resistor unit (optional) 200 VAC models other than shown above: Built-in regenerative resistor 400 VAC SGDV-210D, -260D, -280D, -370D: External regenerative resistor unit (optional) 400 VAC models other than shown above: Built-in regenerative resistor	
Overtravelling (OT) Prevention		Dynamic brake stop at P-OT or N-OT, deceleration to a stop, or free run to a stop	
Safety Functions	Input	/HWBB1, /HWBB2: Baseblock signal for power module	
	Output	EDM1: Status monitor (fixed output) of built-in safety circuit	
	Applicable Standards (Pending) <sup>*2</sup>	EN954 category 3, IEC61508 SIL2	
Option Module		Fully-closed option module	

\*1: Speed regulation is defined as follows:

$$\text{Speed regulation} = \frac{\text{No-load motor speed} - \text{Total load motor speed}}{\text{Rated motor speed}} \times 100\%$$

The motor speed may change due to voltage fluctuation or temperature fluctuation.

The ratio of speed changes to the rated speed represent speed regulation due to voltage and temperature fluctuations.

\*2: Perform risk assessment for the system and confirm that the safety requirements for the standards are fulfilled before using the HWBB function.

## Specifications

### ● Rotary Servomotors

Items		Specifications		
I/O Signal	Encoder Output Pulses	Phase A, phase B, phase C: line driver output The number of dividing pulse: Any setting ratio is available.		
	Sequence Input	Fixed Input	SEN signal	
		Input Signals which can be allocated	Number of Channels	7 channels
			Function	Signal allocations and positive/negative logics can be modified. Homing deceleration switch signal (/DEC), external latch signal (/EXT1 to 3), forward run prohibited (P-OT), reverse run prohibited (N-OT), forward current limit (/P-CL), reverse current limit (/N-CL)
	Sequence Output	Fixed Output	Servo alarm (ALM)	
		Output Signals which can be allocated	Number of Channels	3 channels
Function	Signal allocations and positive/negative logics can be modified. Positioning completion (/COIN), speed coincidence detection (/V-CMP), servomotor rotation detection (/TGON), servo ready (/S-RDY), torque limit detection (/CLT), speed limit detection (/VLT), brake (/BK), warning (/WARN), NEAR (/NEAR)			
Panel Operator	Display	7-segment 1-digit LED (red), LED for MECHATROLINK Communications (green)×3		
	Switch	Rotary switch: 16 positions×2, DIP switch: 4 poles		
MECHATROLINK Communications	Communications Protocol	MECHATROLINK-III		
	Transmission Speed	100 Mbps		
	Transmission Cycle	125 μs, 250 μs, 500 μs, 750 μs, 1 ms to 4 ms (increments of 0.5 ms)		
	Number of Words for Link Transmission	Can be switched between 16-bytes/station, 32-bytes/station and 48-bytes/station.		
	Station Address	03H to EFH (max. number of slaves: 62)		
Command Method	Performance	Position control, speed control, and torque control through MECHATROLINK communications		
	Command Input	MECHATROLINK commands (for sequence, motion, data setting/reference, monitor, adjustment, and other commands.)		

### ● Linear Servomotors

Items		Specifications		
I/O Signal	Encoder Output Pulses	Phase A, phase B, phase C: line driver output The number of dividing pulse: Any setting ratio is available.		
	Sequence Input	Fixed Input	SEN signal	
		Input Signals which can be allocated	Number of Channels	7 channels
			Function	Signal allocations and positive/negative logics can be modified. Homing deceleration switch signal (/DEC), external latch signal (/EXT1 to 3), forward run prohibited (P-OT), reverse run prohibited (N-OT), forward current limit (/P-CL), reverse current limit (/N-CL)
	Sequence Output	Fixed Output	Servo alarm (ALM)	
		Output Signals which can be allocated	Number of Channels	3 channels
Function	Signal allocations and positive/negative logics can be modified. Positioning completion (/COIN), speed coincidence detection (/V-CMP), servomotor movement detection (/TGON), servo ready (/S-RDY), force limit detection (/CLT), speed limit detection (/VLT), brake (/BK), warning (/WARN), NEAR (/NEAR)			
Panel Operator	Display	7-segment 1-digit LED (red), LED for MECHATROLINK Communications (green)×3		
	Switch	Rotary switch: 16 positions×2, DIP switch: 4 poles		
MECHATROLINK Communications	Communications Protocol	MECHATROLINK-III		
	Transmission Speed	100 Mbps		
	Transmission Cycle	125 μs, 250 μs, 500 μs, 750 μs, 1 ms to 4 ms (increments of 0.5 ms)		
	Number of Words for Link Transmission	Can be switched between 16-bytes/station, 32-bytes/station and 48-bytes/station.		
	Station Address	03H to EFH (max. number of slaves: 62)		
Command Method	Performance	Position control, speed control, and force control through MECHATROLINK communications		
	Command Input	MECHATROLINK commands (for sequence, motion, data setting/reference, monitor, adjustment, and other commands.)		

## Power Supply Capacities and Power Losses

The following table shows SERVOPACK's power supply capacities and power losses at the rated output.

Main Circuit Power Supply	Applicable Servomotor Max. Capacity kW	SERVOPACK Model SGD V-	Power Supply Capacity kVA	Output Current Arms	Main Circuit Power Loss W	Regenerative Resistor Power Loss W	Control Circuit Power Loss W	Total Power Loss W
Signal-phase 100 V	0.05	R70F	0.2	0.66	5.4	—	17	22.4
	0.1	R90F	0.3	0.91	7.8			24.8
	0.2	2R1F	0.7	2.1	14.4			31.4
	0.4	2R8F	1.4	2.8	25.6			42.6
Single-phase 200 V	0.05	R70A	0.2	0.66	5.2	—	17	22.2
	0.1	R90A	0.3	0.91	7.4			24.4
	0.2	1R6A	0.7	1.6	13.7			30.7
	0.4	2R8A	1.2	2.8	24.9			41.9
	0.75	5R5A	1.9	5.5	52.7	8	77.7	
	1.5	120A	4	11.6	68.2	10	22	100.2
Three-phase 200 V	0.05	R70A	0.2	0.66	5.1	—	17	22.1
	0.1	R90A	0.3	0.91	7.3			24.3
	0.2	1R6A	0.6	1.6	13.5			30.5
	0.4	2R8A	1	2.8	24.0			41.0
	0.5	3R8A	1.4	3.8	20.1	8	17	45.1
	0.75	5R5A	1.6	5.5	43.8			68.8
	1.0	7R6A	2.3	7.6	53.6			78.6
	1.5	120A	3.2	11.6	65.8	10	22	97.8
	2.0	180A	4	18.5	111.9	16		149.9
	3.0	200A	5.9	19.6	113.8	36	27	161.4
	5.0	330A	7.5	32.9	263.7			326.7
	6.0	470A	10.7	46.9	279.4			(180) <sup>*1</sup>
	7.5	550A	14.6	54.7	357.8	(350) <sup>*2</sup>	48	390.8
	11	590A	21.7	58.6	431.7			479.7
	15	780A	29.6	78	599.0			647.0
Three-phase 400 V	0.5	1R9D	1.1	1.9	24.6	14	21	59.6
	1.0	3R5D	2.3	3.5	46.1			81.1
	1.5	5R4D	3.5	5.4	71.3			106.3
	2.0	8R4D	4.5	8.4	77.9	28	25	130.9
	3.0	120D	7.1	11.9	108.7			161.7
	5.0	170D	11.7	16.5	161.1	36	24	221.1
	6.0	210D	12.4	20.8	172.7			(180) <sup>*3</sup>
	7.5	260D	14.4	25.7	218.6	(350) <sup>*4</sup>	30	245.6
	11	280D	21.9	28.1	294.6			324.6
15	370D	30.6	37.2	403.8	433.8			

\*1: For the optional JUSP-RA04-E regenerative resistor unit.

\*2: For the optional JUSP-RA05-E regenerative resistor unit.

\*3: For the optional JUSP-RA18-E regenerative resistor unit.

\*4: For the optional JUSP-RA19-E regenerative resistor unit.

Notes: 1 SGD V-R70F, -R90F, -2R1F, -2R8F, -R70A, -R90A, -1R6A, and -2R8A SERVOPACKs do not have built-in regenerative resistors.

If the regenerative energy exceeds the specified value, connect an external regenerative resistor (optional).

2 SGD V-470A, -550A, -590A, -780A, -210D, -260D, -280D, -370D SERVOPACKs do not have built-in regenerative resistors.

Be sure to connect a regenerative resistor unit (optional) or an external regenerative resistor (optional).

3 Regenerative resistor power losses are allowable losses. Take the following action if this value is exceeded.

- Remove the lead or short bar that is short-circuiting the SERVOPACK main circuit terminal B2 and B3.

(SGDV-3R8A, -5R5A, -7R6A, -120A, -180A, -200A, -330A, or 400-V class SERVOPACKs.)

- Install an external regenerative resistor (optional).

External Dimensions Units: mm

● Base-mounted SERVOPACKS

(1) Single-phase 100 VAC, Model: SGDV-R70F2□A, -R90F2□A, and -2R1F2□A

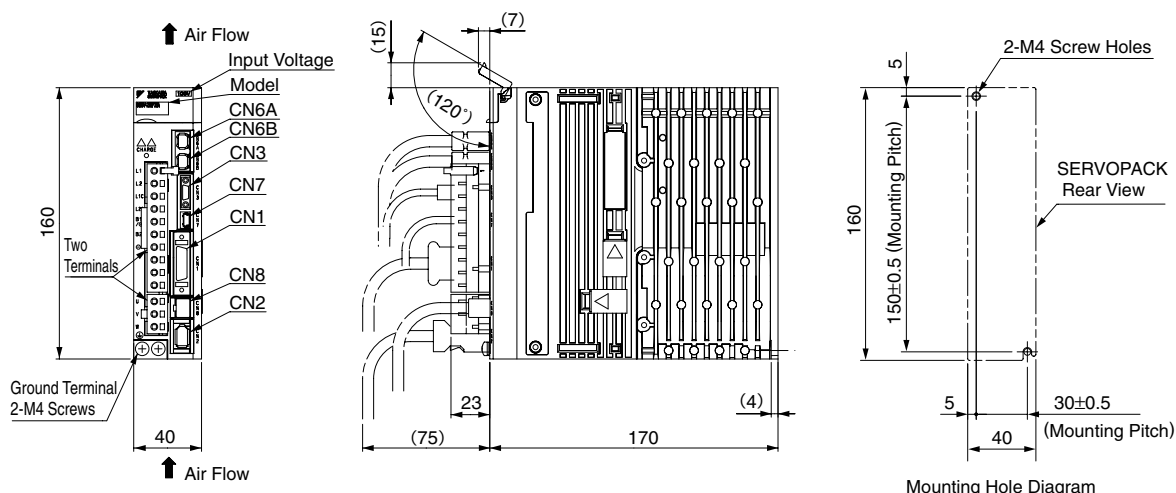

Mounting Hole Diagram

Approx. Mass: 1.0 kg

(2) Single-phase 100 VAC, Model: SGDV-2R8F2□A

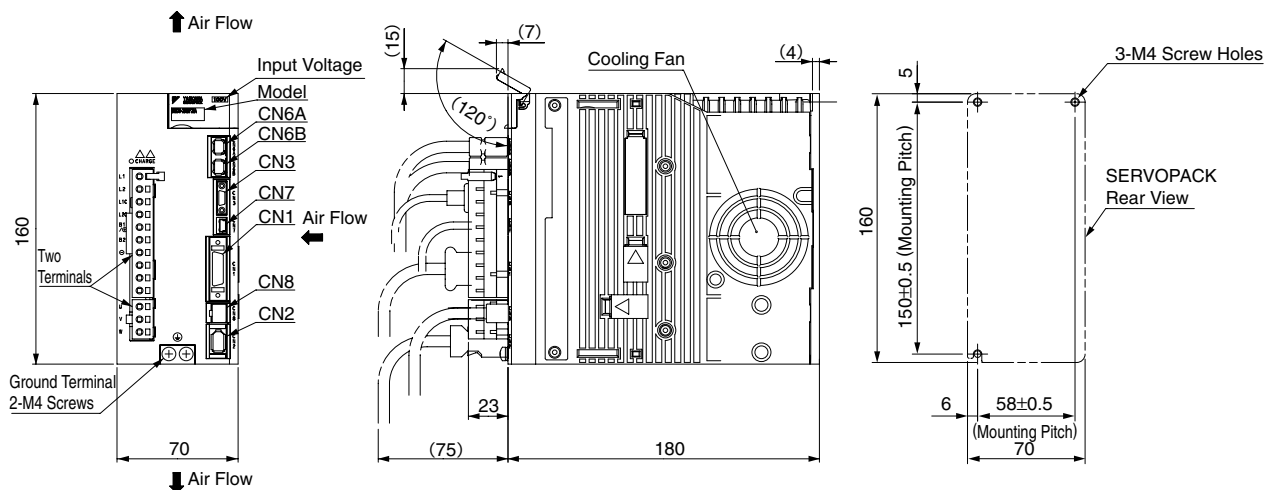

Mounting Hole Diagram

Approx. Mass: 1.5 kg

(3) Three-phase 200 VAC, Model: SGDV-R70A2□B, -R90A2□B, and -1R6A2□B

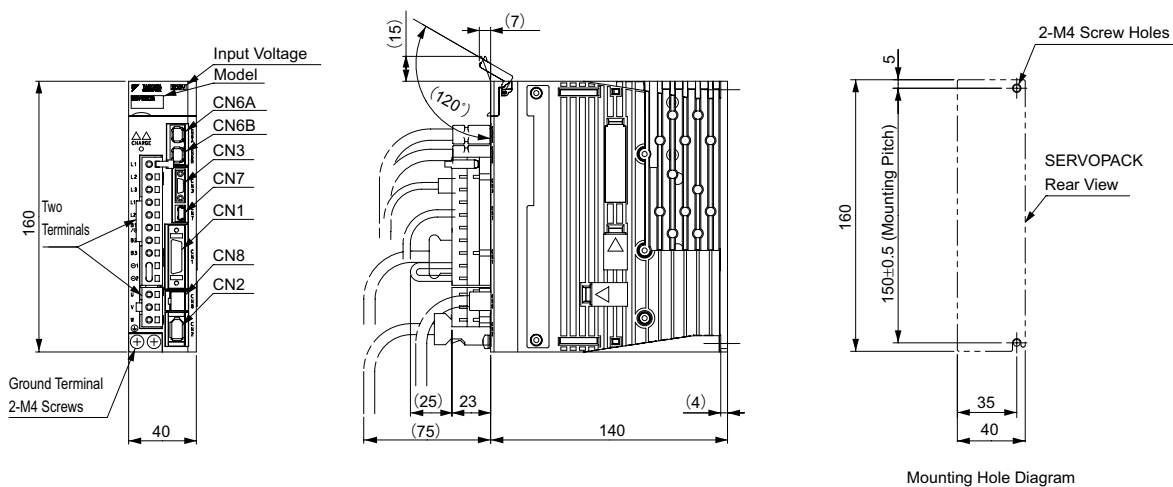

Mounting Hole Diagram

Approx. Mass: 0.9 kg

**External Dimensions** Units: mm

(4) Three-phase 200 VAC, Model: SGDV-2R8A2□B

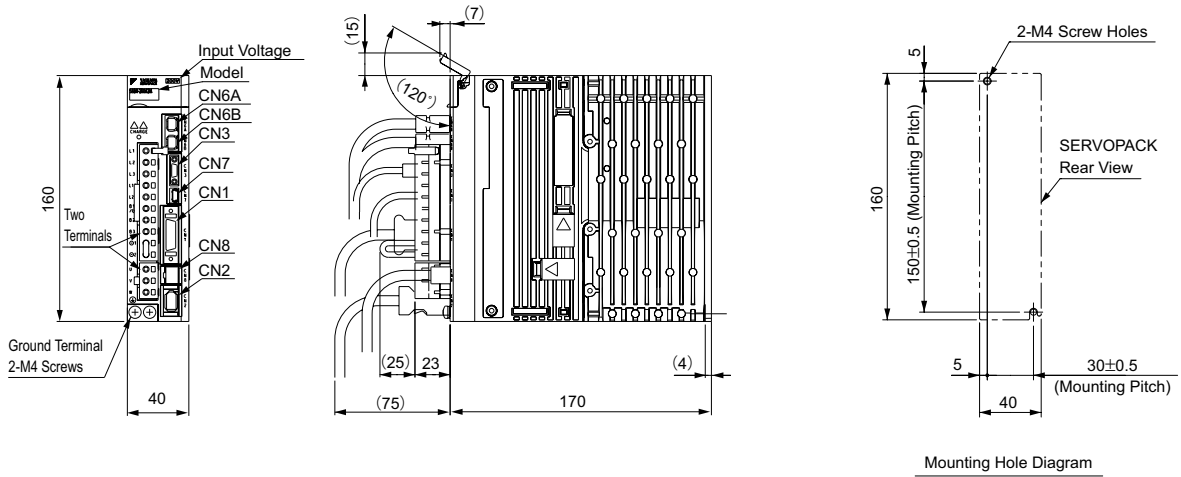

Approx. Mass: 1.0 kg

(5) Three-phase 200 VAC, Model: SGDV-3R8A2□A, -5R5A2□A, and -7R6A2□A

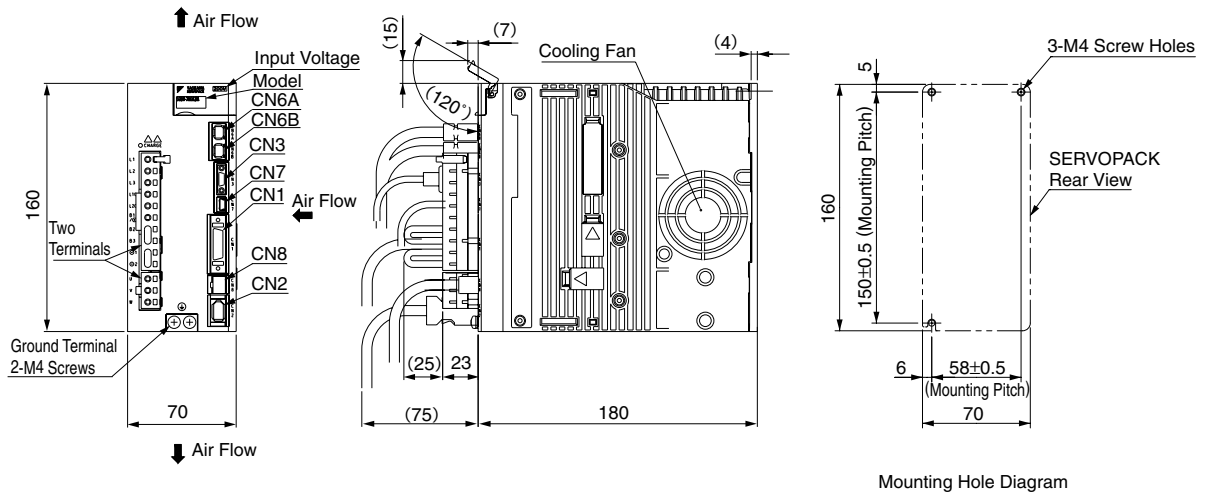

Approx. Mass: 1.5 kg

(6) Three-phase 200 VAC, Model: SGDV-120A2□A

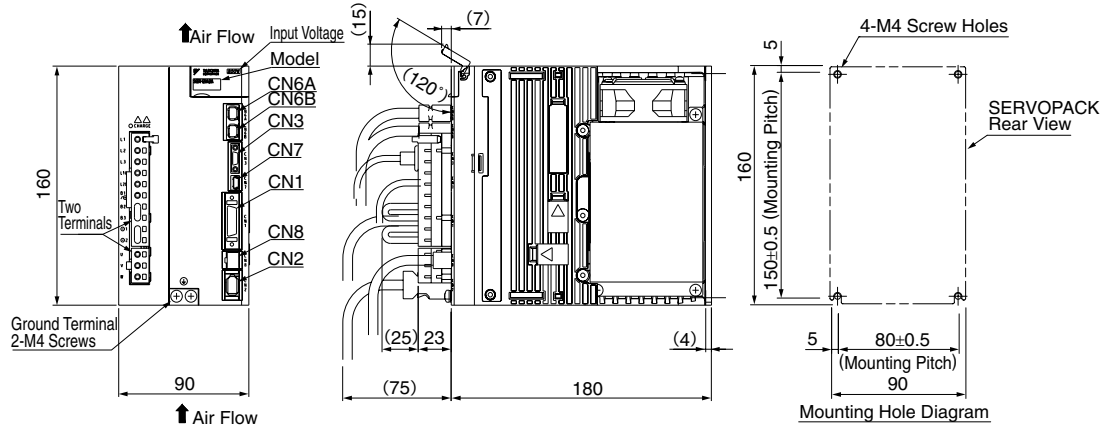

Approx. Mass: 2.4 kg

External Dimensions Units: mm

(7) Three-phase 200 VAC, Model: SGDV-180A2□A and -200A2□A

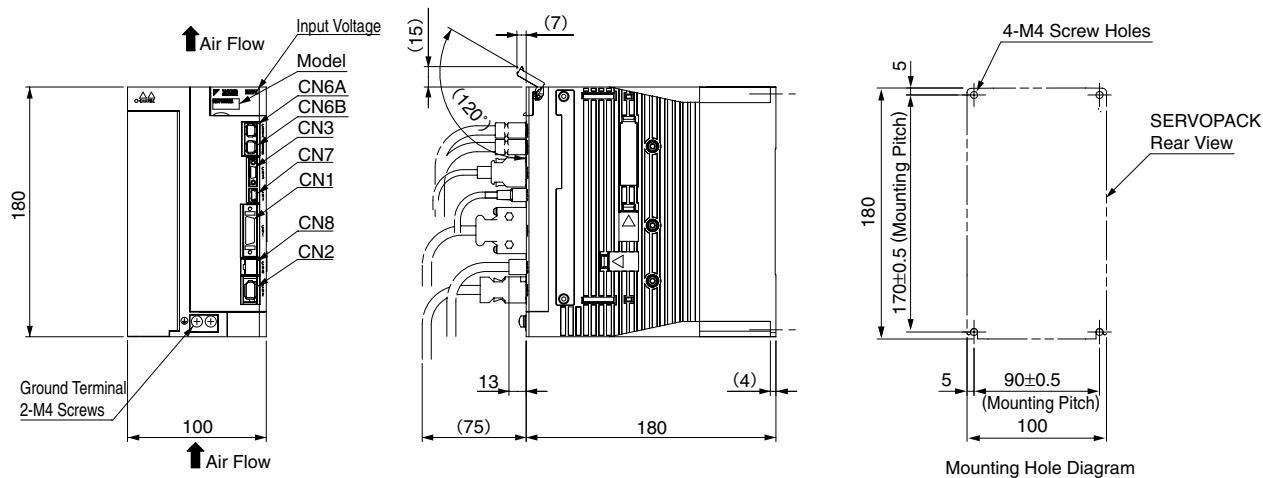

Approx. Mass: 2.8 kg

(8) Three-phase 200 VAC, Model: SGDV-330A2□A

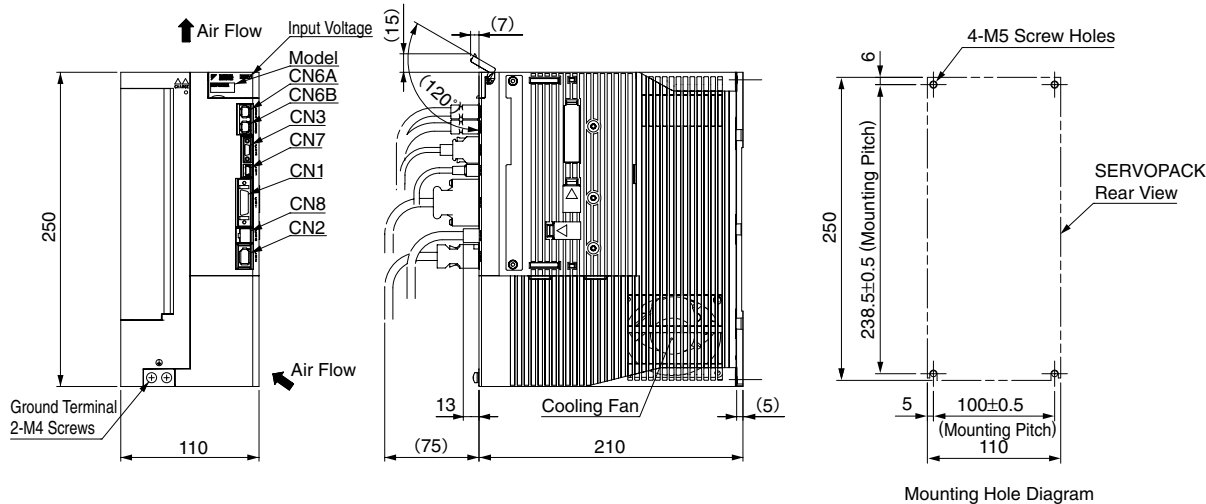

Approx. Mass: 4.6 kg

(9) Three-phase 400 VAC, Model: SGDV-1R9D2□A, -3R5D2□A, and -5R4D2□A

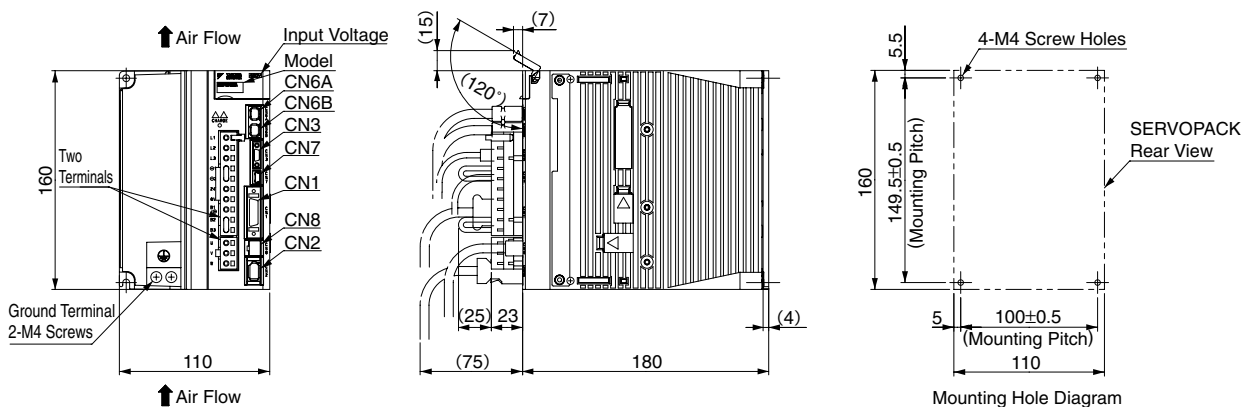

Approx. Mass: 2.7 kg



## External Dimensions Units: mm

(10) Three-phase 400 VAC, Model: SGDV-8R4D2□A and -120D2□A

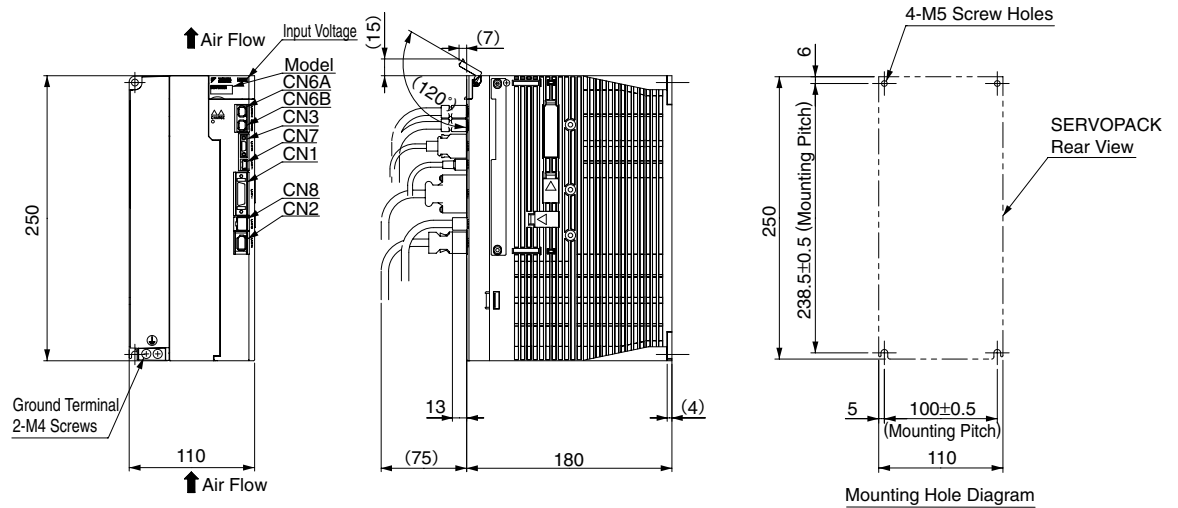

Approx. Mass: 3.7 kg

(11) Three-phase 400 VAC, Model: SGDV-170D2□A

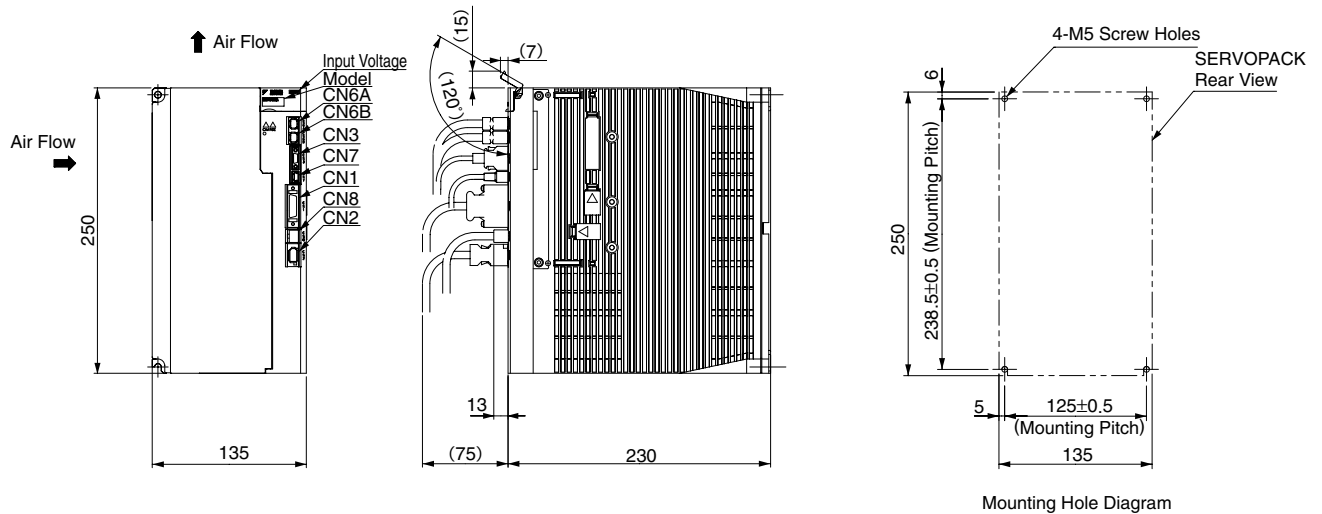

Approx. Mass: 5.6 kg

### Connectors for Base-mounted SERVOPACKs

Port	Model	Pin	Manufacturer
CN1	10226-52A2PL	26	Sumitomo 3M Ltd.
CN2	53984-0671	6	Molex Japan Co., Ltd.
CN3	HDR-EC14LFDTN-SLE-PLUS	14	Honda Tsushin Kogyo Co., Ltd.
CN6A	1981386-1	8	Tyco Electronics AMP K.K.
CN6B	1981386-1	8	Tyco Electronics AMP K.K.
CN7	MNC23-5K5H00	5	ADVANCED-CONNECTEK INC.
CN8	1981080-1	8	Tyco Electronics AMP K.K.

Note: The connectors above or their equivalents are used for SERVOPACKs.

Selecting Cables

- Cables for **CN1** **CN3** **CN5** **CN6** **CN7** **CN8** (MECHATROLINK-III Communications Reference Type SERVOPACKs)

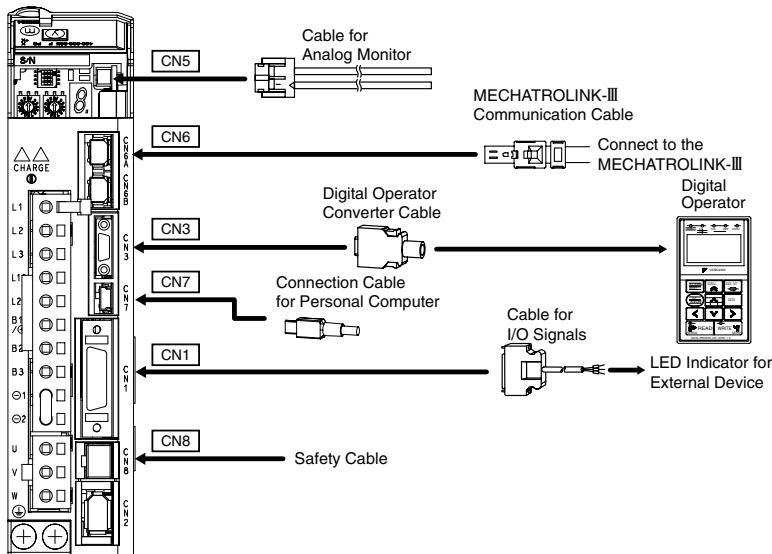

Name	Length	Order No.	Specifications	Details	
<b>CN1</b> Cables for I/O Signals	Connector Kit		JZSP-CSI9-2-E	Soldered	(1)
	Connector Terminal Converter Unit	0.5 m	SBK-U-VBA-A5	Terminal Block and 0.5 m Connection Cable	(2)
		1 m	SBK-U-VBA-01		
		3 m	SBK-U-VBA-03		
	Cable with Loose wire at One End	1 m	JZSP-CSI02-1-E		(3)
		2 m	JZSP-CSI02-2-E		
3 m		JZSP-CSI02-3-E			
<b>CN3</b>	Digital Operator		JUSP-OP05A-1-E	With Connection Cable (1 m)	(4)
	Digital Operator Converter Cable*1	0.3 m	JZSP-CVS05-A3-E	Cable with Connectors at Both Ends	(5)
<b>CN7</b>	Connection Cables for Personal Computer	2.5 m	JZSP-CVS06-02-E	Cable with Connectors at Both Ends	(6)
<b>CN6A</b> <b>CN6B</b> MECHATROLINK-III Communication Cable	Cables with Connectors at Both Ends (Without Ferrite Core)	0.2 to 50 m	JEPMC-W6012-□□-E		(7)
	Cables with Connectors at Both Ends (With Ferrite Core)*2	10 to 75 m	JEPMC-W6013-□□-E		(8)
	Cable with Loose Wire at One End	0.5 to 50 m	JEPMC-W6014-□□-E		(9)
<b>CN5</b> Cables for Analog Monitor	1 m	JZSP-CA01-E	SERVOPACK End	(10)	
<b>CN8</b> Cables for Safety Functions	Cables with Connector*3	3 m	JZSP-CVH03-03-E		(11)
	Connector kit*4		Contact Tyco Electronics AMP K.K. Product name : Industrial Mini I/O D-shape Type1 Plug Connector Kit Model : 2013595-1		

\*1 : A converter cable is required to use  $\Sigma$ -III series digital operators (model: JUSP-OP05A) for  $\Sigma$ -V series SERVOPACKs.  
 \*2 : Currently in pre-release. Will be available soon.  
 \*3 : When using the safety function, connect this cable to the safety devices.  
 Even when not using the safety function, use SERVOPACKs with the Safe Jumper Connector (model: JZSP-CVH05-E) connected.  
 \*4 : Use the connector kit when you make cables yourself.

## Selecting Cables Units: mm

### (1) Connector Kit for CN1

Use the following connector and cable to assemble the cable. The CN1 connector kit includes one case and one connector.

Connector Kit		Case		Connector	
Model		Model	Qty	Model	Qty
JZSP-CS19-2-E		10326-52A0-008*	1 set	10126-3000PE* (Soldered)	1

\* : Manufactured by Sumitomo 3M Ltd.

#### Cable Size

Item	Specifications
Cable	Use twisted-pair or twisted-pair shielded wire.
Applicable Wires	AWG24 □ 26 □ 28 □ 30
Cable Finished Diameter	16 dia. max.

#### Dimensional Drawings of Case

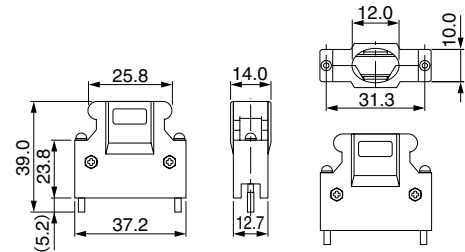

#### Dimensional Drawings of Connector

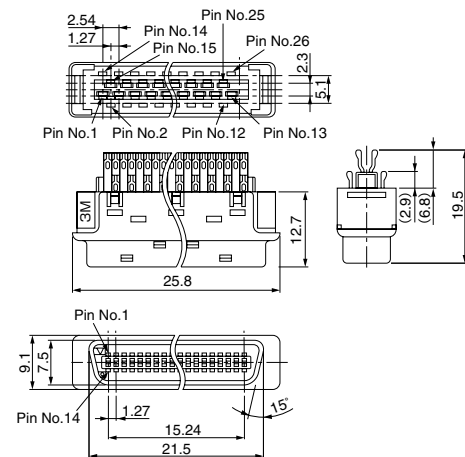

### (2) Connector Terminal Converter Unit for CN1 (SBK-U-VBA-xx)

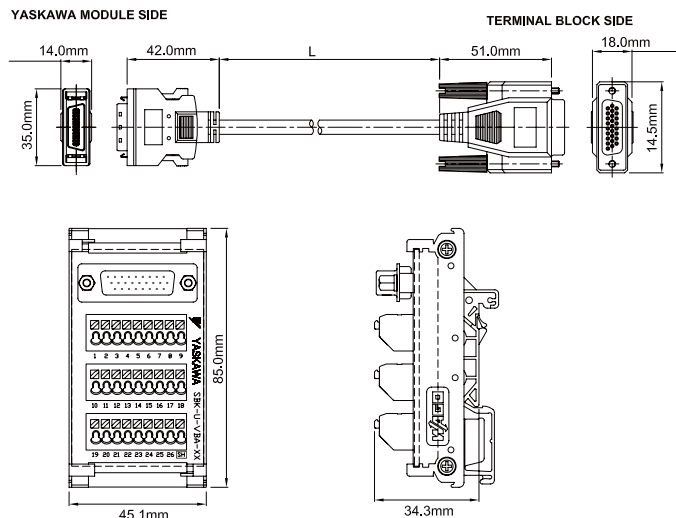

CABLE SPECIFICATION (mm)	
OUTER DIAMETER	6.5 +/- 0.2mm
BENDING RADIUS	6 x O.D. MINIMUM 15 x O.D. FOR LONG TERM RELIABILITY

ITEM#	L = LENGTH (mm)
SBK-U-VBA-A5	500 +/- 38.1
SBK-U-VBA-01	1000 +/- 38.1
SBK-U-VBA-03	3000 +/- 38.1

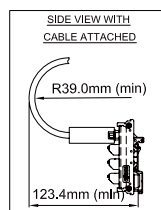

#### SBK-U-VBA-xx Function Chart for SGDV Servo Amplifier

Pin No.	SGDV Mechatrolink-II type / SGDV Option type	
	Signal	Function
1	/BK+ (/SO1+)	Brake interlock output (+) (General purpose output 1 (+))
2	/BK- (/SO1-)	Brake interlock output (-) (General purpose output 1 (-))
3	ALM+	Servo alarm output (+)
4	ALM-	Servo alarm output (-)
5	-	
6	+24VIN	Control power supply for sequence signal input
7	P-OT (/SI1)	Forward run prohibited input (General purpose input 1)
8	N-OT (/SI2)	Reverse run prohibited input (General purpose input 2)
9	/DEC (/SI3)	Zero-point return deceleration switch input (General purpose input 3)
10	/EXT1 (/SI4)	External latch signal 1 input (General purpose input 4)
11	/EXT2 (/SI5)	External latch signal 2 input (General purpose input 5)
12	/EXT3 (/SI6)	External latch signal 3 input (General purpose input 6)
13	/SI0	General purpose input 0
14	BAT (+)	Battery (+) input
15	BAT (-)	Battery (-) input
16	SG	Signal ground
17	PAO	Phase-A pulse output (+)
18	/PAO	Phase-A pulse output (-)
19	PBO	Phase-B pulse output (+)
20	/PBO	Phase-B pulse output (-)
21	PCO	Phase-C pulse output (+)
22	/PCO	Phase-C pulse output (-)
23	/SO2+	General purpose output 2 (+)
24	/SO2-	General purpose output 2 (-)
25	/SO3+	General purpose output 3 (+)
26	/SO3-	General purpose output 3 (-)

Note: General purpose input and output signals are shown with their default signals assigned - signal assignment may have been changed by parameter

Selecting Cables Units: mm

(3) Cable with Loose Wires at One End for CN1  
Dimensional Drawings of Cable

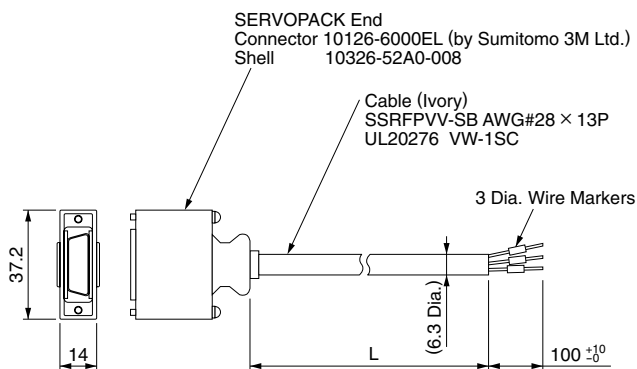

Model	Cable Length
JZSP-CSI02-1-E	1 m
JZSP-CSI02-2-E	2 m
JZSP-CSI02-3-E	3 m

● Cable with Loose Wires at One End for CN1  
Connection Diagram of JZSP-CSI02-□-E Cable

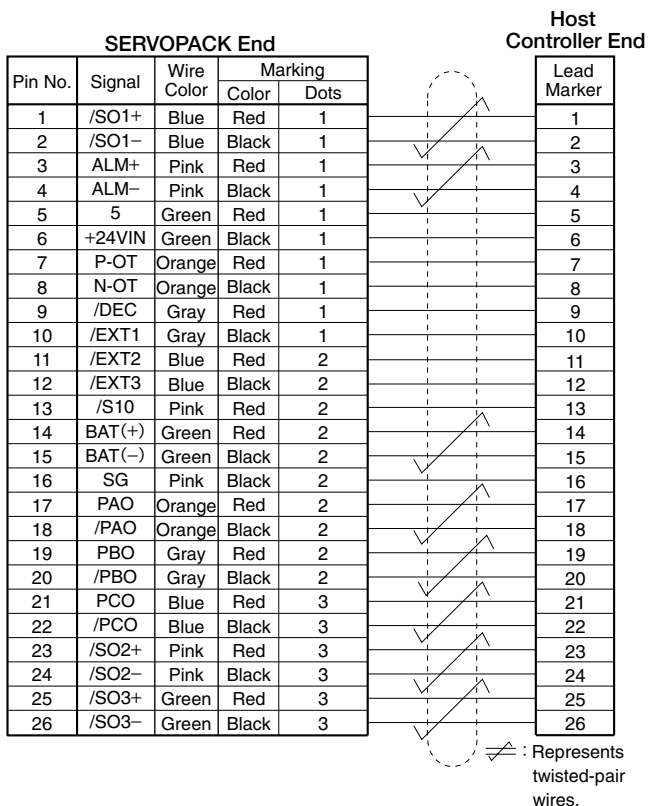

(4) Digital Operator (Model: JUSP-OP05A-1-E)

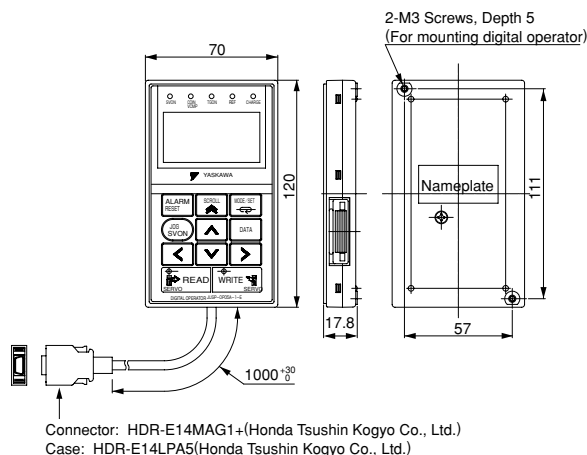

(5) Digital Operator Converter Cable for CN3  
(Model: JZSP-CVS05-A3-E)

A converter cable is required to use  $\Sigma$ -III series digital operators (model: JUSP-OP05A) for  $\Sigma$ -V series SERVOPACKs.

· Dimensional Drawings

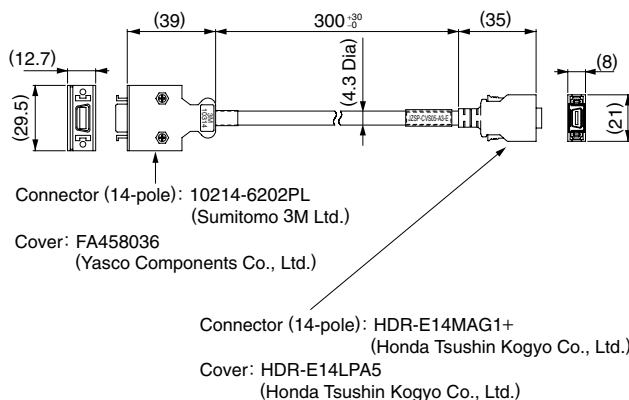

## Selecting Cables Units: mm

### (6) Connection Cable for Personal Computer for CN7 (Model: JZSP-CVS06-02-E)

· Dimensional Drawings

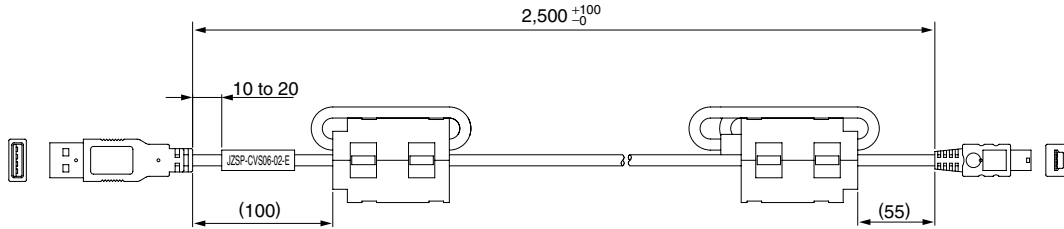

**IMPORTANT** Use a cable specified by Yaskawa.  
When using other cables, operation cannot be guaranteed.

### (7) MECHATROLINK-III Communications Cable for CN6 (Model: JEPMC-W6012-□□-E)

· Dimensional Drawings

Cables with Connectors at Both Ends (Without Ferrite Core)

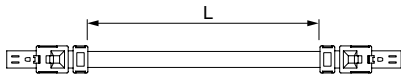

Model	Cable Length (L)
JEPMC-W6012-A2-E	0.2 m
JEPMC-W6012-A5-E	0.5 m
JEPMC-W6012-01-E	1 m
JEPMC-W6012-02-E	2 m
JEPMC-W6012-03-E	3 m
JEPMC-W6012-04-E	4 m
JEPMC-W6012-05-E	5 m
JEPMC-W6012-10-E	10 m
JEPMC-W6012-20-E	20 m
JEPMC-W6012-30-E	30 m
JEPMC-W6012-50-E	50 m

### (8) MECHATROLINK-III Communications Cable for CN6 (Model: JEPMC-W6013-□□-E)

· Dimensional Drawings

Cables with Connectors at Both Ends (With Ferrite Core)

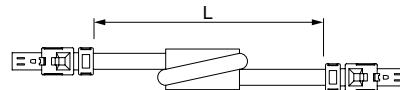

Model	Cable Length (L)
JEPMC-W6013-10-E	10 m
JEPMC-W6013-20-E	20 m
JEPMC-W6013-30-E	30 m
JEPMC-W6013-50-E	50 m
JEPMC-W6013-75-E	75 m

### (9) MECHATROLINK-III Communications Cable for CN6 (Model: JEPMC-W6014-□□-E)

· Dimensional Drawings

Cable with Loose Wire at One End

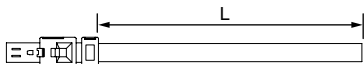

Model	Cable Length (L)
JEPMC-W6014-A5-E	0.5 m
JEPMC-W6014-01-E	1 m
JEPMC-W6014-03-E	3 m
JEPMC-W6014-05-E	5 m
JEPMC-W6014-10-E	10 m
JEPMC-W6014-30-E	30 m
JEPMC-W6014-50-E	50 m

**IMPORTANT** Use a MECHATROLINK-III communications cable specified by Yaskawa. When using other cables, noise resistance may be reduced, and operation cannot be guaranteed.

## Selecting Cables Units: mm

### (10) Cable for Analog Monitor for CN5 (Model: JZSP-CA01-E)

#### · Dimensional Drawings

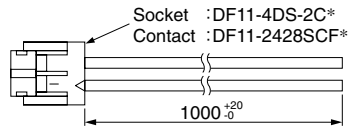

\* : Manufactured by Hirose Electric Corporation.

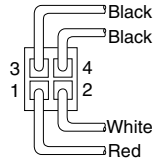

View from Cable End

#### · Specifications

Pin No.	Cable Color	Signal	Standard Settings
1	Red	Analog Monitor 2	Motor speed : 1V/1000 min <sup>-1</sup>
2	White	Analog Monitor 1	Torque reference : 1V/100 □ rated torque
3, 4	Black (2 cables)	GND(0V)	-

Note : The specifications above are factory settings. Monitor specifications can be changed by changing parameters Pn006 and Pn007.

### (11) Cable with Connector for CN8 (Model: JZSP-CVH03-03-E)

#### · Dimensional Drawings

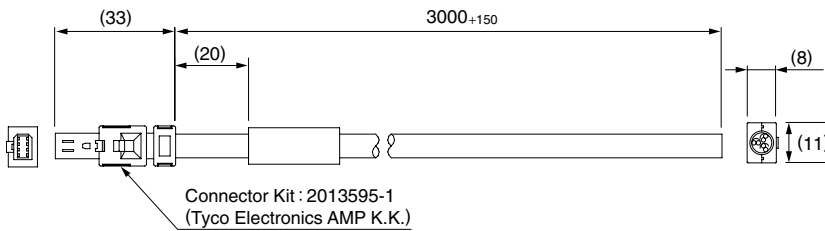

#### · Specifications

Pin No.	Signal	Lead Color	Marking Color
1	Not used	-	-
2	Not used	-	-
3	/HWBB1-	White	Black
4	/HWBB1+	White	Red
5	/HWBB2-	Gray	Black
6	/HWBB2+	Gray	Red
7	EDM1-	Orange	Black
8	EDM1+	Orange	Red

# SERVOPACK with Additional Options



## Model Designations

■ Limited Stock Items

SGDV R70 A 0 1 B 002 00 0 001

Σ-V Series SGDV SERVOPACK  
Current

Voltage	Code	Applicable Servomotor Max. Capacity kW
100 V	R70	0.05
	R90	0.1
	2R1	0.2
	2R8	0.4
200 V	R70 <sup>*3</sup>	0.05
	R90 <sup>*3</sup>	0.1
	1R6 <sup>*3</sup>	0.2
	2R8 <sup>*3</sup>	0.4
	3R8	0.5
	5R5 <sup>*3</sup>	0.75
	7R6	1.0
	120 <sup>*4</sup>	1.5
	180	2.0
	200	3.0
	330	5.0
	470	6.0
	550	7.5
	590	11
780	15	
400V	1R9	0.5
	3R5	1.0
	5R4	1.5
	8R4	2.0
	120	3.0
	170	5.0
	210	6.0
	260	7.5
	280	11
	370	15

\*3: These amplifiers can be powered with single or three-phase.

\*4: SGDV-120A□1A008000, a special version of the 1.5kW amplifier can be used for single-phase operation.

### Option Function

Code	Specifications
001 <sup>*1</sup>	Fully-closed loop
010 <sup>*1</sup>	Functional Safety
100 <sup>*2</sup>	Indexer
101 <sup>*2</sup>	Indexer and Fully-closed loop
200 <sup>*2</sup>	EtherCAT (CoE) communications reference
201 <sup>*2</sup>	EtherCAT (CoE) communications reference and Fully-closed loop control
210 <sup>*2</sup>	EtherCAT (CoE) communications reference and Functional Safety
300 <sup>*2</sup>	MP2600iec Single Axis Controller

\*1 This option only available with interface types 0 and 1.

\*2 This option only available with interface type E

### Options

Code	Specifications
002000	Base-mounted, varnish(standard)
008000	Single-phase, 200VAC Input (model: SGDV-120A01A008000)

### Design Revision

Code	Specifications
B	Standard

### Motor Type

Code	Specifications
1	Rotary Servomotors
5 <sup>*5</sup>	Linear Servomotors

\*5 Fully Closed Loop option not available with linear style amps.

### Interface Options

Code	Specifications
0	Analog voltage/pulse train reference type
1	MECHATROLINK-II communication reference type
E	Other control architecture type (i.e. MP2600iec)

### Voltage

Code	Specifications
F	100 VAC
A	200 VAC
D	400 VAC

## Additional Options

### MP2600iec Single Axis Controller Option

- IEC61131-3 standardized programming for the Sigma-5 servo system
- Scalable with the MP2000iec multi-axis controller platform via the common programming environment, MotionWorks IEC
- Built in Ethernet/IP and Modbus TCP/IP (master and slave) allow for connection to most PLC's and expansion I/O
- PLCopen function blocks with MotionWorks IEC simplify programming, while a diagnostic web server reduces field maintenance time
- Optional OPC server allows for data exchange with Windows based HMI and SCADA systems

### Full Closed Loop Option

- Allows the user to close the position loop around a secondary feedback device placed near the load
- Helps to eliminate the effects of mechanical compliance and thermal variances of mechanical components allowing for more precise control and improved machine performance

### EtherCAT (CoE) Option

- Implements the EtherCAT open EtherNet based real-time communication protocol
- Compatibility with any EtherCAT master that adheres to the CAN over EtherCAT (CoE) device profile specification (CiA402)
- Variety of different system architectures: cascade, line star, ring
- Seven different control modes available

### Indexer Option

- Provides point-to-point positioning without complex programming
- Up to 256 programmable positioning points
- Simple wizard-based setup with SigmaWin+ software

### Functional Safety Option

- TUV Sud certified compliance with the latest standards
- Safety standards: Safe Torque Off (STO), Safe Stop 1 (SS1), Safe Stop 2 (SS2), Safely Limited Stop (SLS)

## Product Labeling

The three digit option function code allows for expandability of the servo amplifier's functionality. Each digit of the code defines a different type of option

- First Digit (Control Architecture): compatible with various communication interfaces or single-axis control architectures.
- Second Digit (Safety): compatible with EN60204-1 stop category 1 and 2 (stop category 0 is standard)
- Third Digit (Feedback): compatible with fully-closed loop control

NOTE: Amplifiers with Interface Options 0 and 1 can accommodate option modules that utilize the 2nd and 3rd digits of the Option Module Code (the first digit will always be 0 for these amplifiers). Amplifiers with Interface Option E can accommodate option modules that utilize all 3 digits of the Option Module Code.

Combination Example:

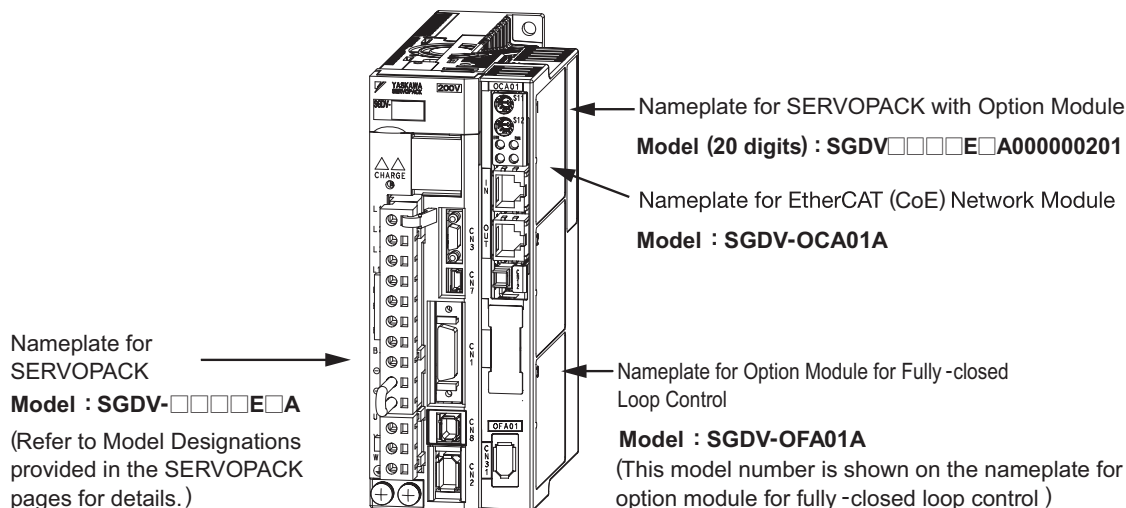



## Ratings

### Single-phase 100 V

SERVOPACK Model	SGDV□□□□	R70F	R90F	2R1F	2R8F
Applicable Servomotor Max. Capacity	kW	0.05	0.1	0.2	0.4
Continuous Output Current	$A_{rms}$	0.66	0.91	2.1	2.8
Max. Output Current	$A_{rms}$	2.1	2.9	6.5	9.3
Main Circuit (Single Phase)	100 to 115 VAC +10% to -15% 50/60 Hz				
Control Circuit (Single Phase)	100 to 115 VAC +10% to -15% 50/60 Hz				

### Single-phase 200 V

SERVOPACK Model	SGDV□□□□	R70A	R90A	1R6A	2R8A	5R5A	120
Applicable Servomotor Max. Capacity	kW	0.05	0.1	0.2	0.4	0.75	1.5
Continuous Output Current	$A_{rms}$	0.66	0.91	1.6	2.8	5.5	11.6
Max. Output Current	$A_{rms}$	2.1	2.9	6.5	9.3	16.9	28
Main Circuit (Single Phase)	220 to 230 VAC +10% to -15% 50/60 Hz						
Control Circuit (Single Phase)	220 to 230 VAC +10% to -15% 50/60 Hz						

### Three-phase 200 V

SERVOPACK Model	SGDV□□□□	R70A	R90A	1R6A	2R8A	3R8A	5R5A	7R6A	120A	180A	200A	330A	470A	550A	590A	780A
Applicable Servomotor Max. Capacity	kW	0.05	0.1	0.2	0.4	0.5	0.75	1.0	1.5	2.0	3.0	5.0	6	7.5	11	15
Continuous Output Current	$A_{rms}$	0.66	0.91	1.6	2.8	3.8	5.5	7.6	11.6	18.5	19.6	32.9	46.9	54.7	58.6	78
Max. Output Current	$A_{rms}$	2.1	2.9	6.5	9.3	11	16.9	17	28	42	56	84	110	130	140	170
Main Circuit	Three-phase 200 to 230 VAC +10% to -15% 50/60 Hz															
Control Circuit	Single-phase 200 to 230 VAC +10% to -15% 50/60 Hz															

### Three-phase 400 V

SERVOPACK Model	SGDV□□□□	1R9D	3R5D	5R4D	8R4D	120D	170D	210D	260D	280D	370D
Applicable Servomotor Max. Capacity	kW	0.5	1.0	1.5	2.0	3.0	5.0	6	7.5	11	15
Continuous Output Current	$A_{rms}$	1.9	3.5	5.4	8.4	11.9	16.5	20.8	25.4	28.1	37.2
Max. Output Current	$A_{rms}$	5.5	8.5	14	20	28	42	55	65	70	85
Main Circuit	Three-phase 380 to 480 VAC +10% to -15% 50/60 Hz										
Control Circuit	24 VDC ±15%										

## ● SERVOPACK Overload Characteristics

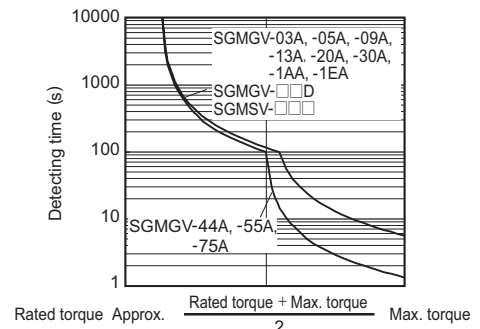
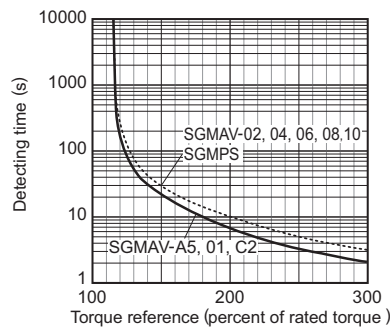
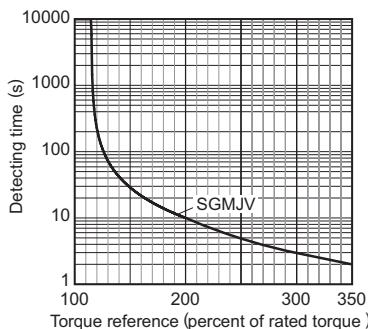

Note: Overload characteristics shown above do not guarantee continuous duty of 100% or more output. Use a servomotor with effective torque within the continuous duty zone of *Torque-Motor Speed Characteristics*.

## Specifications

Items	Specifications
Control Method	IGBT PWM control, sine-wave driven
Feedback	Rotary Servomotors Serial encoder: 13-bit (incremental encoder) : 17-bit (incremental/absolute encoder) : 20-bit (incremental/absolute encoder)
	Linear Servomotors <sup>*)</sup> Serial converter or serial data
Operating Conditions	Surrounding/Storage Temperature Surrounding temperature: 0 to +55°C, storage temperature: -20 to +85°C
	Ambient/Storage Humidity 90%RH or less (no condensation)
	Vibration/Shock Resistance Vibration resistance: 4.9 m/s <sup>2</sup> , Shock resistance: 19.8 m/s <sup>2</sup>
	Protection class/Pollution degree Protection class: IP 1X, pollution degree: 2 Do not use SERVOPACKs in the following locations: ·Locations subject to corrosive or flammable gases ·Locations subject to exposure to water, oil, or chemicals ·Locations subject to dust, including iron dust, and salts
Others	Do not use SERVOPACKs in the following locations: ·Locations subject to static electricity noise, strong electromagnetic/magnetic fields, radioactivity
Elevation	1000 m or less

## Specifications

Items		Specifications		
Compliant Standards		UL508C EN50178, EN55011/A2 group1 classA, EN61000-6-2, EN61800-3, EN61800-5-1, EN954-1, IEC61508-1 to 4		
Configuration		Standard: Base-mounted; Optional: Rack-mounted, Duct-ventilated		
Performance	Speed Control Range		1:5000 (The lowest speed of the speed control range is the speed at which the servomotor will not stop with a rated torque load.)	
	Speed Regulation <sup>2</sup>	Load Regulation	0% to 100% load: ±0.01% max. (at rated speed)	
		Voltage Regulation	Rated voltage: ±10% : 0% (at rated speed)	
		Temperature Regulation	25±25°C : ±0.1% max. (at rated speed)	
Torque Control Tolerance (Repeatability)		±1%		
I/O Signals	Encoder Output Pulses		Phase A, phase B, phase C: line driver output The number of dividing pulse: Any setting ratio is available.	
	Sequence Input	Input Signals which can be allocated	No. of Channels	7 channels
			Functions	The signal allocation and positive/negative logic can be modified. Forward run prohibited (/P-OT), reverse run prohibited (/N-OT), forward torque limit (/P-CL), reverse torque limit (/N-CL), general-purpose input signal (/SI0 to /SI6) <sup>3</sup>
	Sequence Output	Output Signals which can be allocated	Fixed Output	Servo alarm (ALM)
			No. of Channels	3 channels
	Functions	The signal allocation and positive/negative logic can be modified. Positioning completion (/COIN), speed coincidence detection(/V-CMP), servomotor rotation detection (/TGON), servo ready(/S-RDY), torque limit detection (/CLT), speed limit detection(/VLT), brake (/BK), warning (/WARN), near (/NEAR)		
Communications	RS-422A Communications	Interface	Digital operator, RS-422A port of personal computers etc.	
		1:N communications	RS-422A port: N= 15 max. available	
		Axis address setting	Set by parameters	
	USB Communications	Interface	Personal computers (application: engineering tool SigmaWin+)	
		Communications Standard	Compliant with USB 1.1 standard (12 Mbps)	
Display		CHARGE and POWER (seven-segment display)		
Analog Monitor		Number of points: 2 Output voltage: ±10 VDC (linearity effective range ±8 V) Resolution: 16 bit Accuracy: ±20 mV (Typ) Max. output current: ±10 mA Settling time (±1%): 1.2 ms (Typ)		
Dynamic Brake (DB)		Activated when the power supply for the main circuit or the SERVOPACK is OFF, when overtravel (OT) or a servo alarm occurs, or during a hardwired base block.		
Regenerative Processing		100 VAC model: External regenerative resistor (optional) 200 VAC SGD V-R70A, -R90A, -1R6A, -2R8A: External regenerative resistor (optional) 200 VAC SGD V-470A, -550A, -590A, -780A: External regenerative resistor unit (optional) 200 VAC models other than shown above: Built-in regenerative resistor 400 VAC SGD V-210D, -260D, -280D, -370D: External regenerative resistor unit (optional) 400 VAC models other than shown above: Built-in regenerative resistor		
Overtravell (OT) Prevention		Dynamic brake stop at P-OT or N-OT, deceleration to a stop, or free run to a stop		
Protective Functions		Overcurrent, Overvoltage, low voltage, overload, regeneration error		
Utility Functions		Gain adjustment, alarm history, JOG operation, origin search, etc.		
Safety Functions	Input	/HWBB1, /HWBB2: Baseblock signal for power module		
	Output	EDM1: Status monitor (fixed output) of built-in safety circuit		
Option Modules		Fully-closed option module, EtherCAT (CoE)		

\*1: Under development

\*2: Speed regulation is defined as follows:

$$\text{Speed regulation} = \frac{\text{No-load motor speed} - \text{Total load motor speed}}{\text{Rated motor speed}} \times 100\%$$

The motor speed may change due to voltage variations or temperature variation. The ratio of speed changes to the rated speed represent speed regulation due to voltage and temperature variations.

\*3: For details on the functions of the general-purpose input signals /SI0 to /SI6, refer to the manual of the command (option) module being used.

## Power Supply Capacities and Power Losses

The following table shows SERVOPACK's power supply capacities and power losses at the rated output.

Main Circuit Power Supply	Applicable Servomotor Max. Capacity kW	SERVOPACK Model SGD V	Power Supply Capacity kVA	Output Current A	Main Circuit Power Loss W	Regenerative Resistor Power Loss W	Control Circuit Power Loss W	Total Power Loss W
Signal-phase 100 V	0.05	R70F	0.2	0.66	5.4	—	17	22.4
	0.1	R90F	0.3	0.91	7.8			24.8
	0.2	2R1F	0.7	2.1	14.4			31.4
	0.4	2R8F	1.4	2.8	25.6			42.6
Single-phase 200 V	0.05	R70A	0.2	0.66	5.2	—	17	22.2
	0.1	R90A	0.3	0.91	7.4			24.4
	0.2	1R6A	0.7	1.6	13.7			30.7
	0.4	2R8A	1.2	2.8	24.9			41.9
	0.75	5R5A	1.9	5.5	52.7	8	77.7	
	1.5	120A	4	11.6	68.2	10	22	100.2
Three-phase 200 V	0.05	R70A	0.2	0.66	5.1	—	17	22.1
	0.1	R90A	0.3	0.91	7.3			24.3
	0.2	1R6A	0.6	1.6	13.5			30.5
	0.4	2R8A	1	2.8	24.0			41.0
	0.5	3R8A	1.4	3.8	20.1	8	17	45.1
	0.75	5R5A	1.6	5.5	43.8			68.8
	1.0	7R6A	2.3	7.6	53.6	10	17	78.6
	1.5	120A	3.2	11.6	65.8			97.8
	2.0	180A	4	18.5	111.9	16	22	149.9
	3.0	200A	5.9	19.6	113.8			161.4
	5.0	330A	7.5	32.9	263.7	36	27	326.7
	6.0	470A	10.7	46.9	279.4	(180) <sup>*1</sup>	33	312.4
	7.5	550A	14.6	54.7	357.8	(350) <sup>*2</sup>		390.8
	11	590A	21.7	58.6	431.7		48	479.7
15	780A	29.6	78	599.0	647.0			
Three-phase 400 V	0.5	1R9D	1.1	1.9	24.6	14	21	59.6
	1.0	3R5D	2.3	3.5	46.1			81.1
	1.5	5R4D	3.5	5.4	71.3			106.3
	2.0	8R4D	4.5	8.4	77.9	28	25	130.9
	3.0	120D	7.1	11.9	108.7			161.7
	5.0	170D	11.7	16.5	161.1	36	24	221.1
	6.0	210D	12.4	20.8	172.7	(180) <sup>*3</sup>	27	199.7
	7.5	260D	14.4	25.7	218.6			245.6
	11	280D	21.9	28.1	294.6	(350) <sup>*4</sup>	30	324.6
15	370D	30.6	37.2	403.8	433.8			

\*1: For the optional JUSP-RA04-E regenerative resistor unit.

\*2: For the optional JUSP-RA05-E regenerative resistor unit.

\*3: For the optional JUSP-RA18-E regenerative resistor unit.

\*4: For the optional JUSP-RA19-E regenerative resistor unit.

Notes: 1 SGDVR70F, R90F, 2R1F, 2R8F, R70A, R90A, 1R6A, and 2R8A SERVOPACKs do not have built-in regenerative resistors.

If the regenerative energy exceeds the specified value, connect an external regenerative resistor (optional).

2 SGDVR470A, 550A, 590A, 780A, 210D, 260D, 280D, 370D SERVOPACKs do not have built-in regenerative resistors.

Be sure to connect a regenerative resistor unit (optional) or an external regenerative resistor (optional).

3 Regenerative resistor power losses are allowable losses. Take the following action if this value is exceeded.

· Remove the lead or short bar that is short-circuiting the SERVOPACK main circuit terminal B2 and B3.

(SGDV3R8A, 5R5A, 7R6A, 120A, 180A, 200A, 330A, or 400 V class SERVOPACKs.)

· Install an external regenerative resistor (optional).

**External Dimensions** Units: mm (for Analog Voltage/Pulse Train Reference Type SERVOPACKs)

The following drawings illustrate the external dimensions of SERVOPACKs with Interface Options 0 and 1 with option modules.

● **Base-mounted SERVOPACKs**

- (1) Single-phase 100 VAC, Model:SGDVR70F0□A002000□□□, SGDVR90F0□A002000□□□, and SGDV2R1F0□A002000□□□

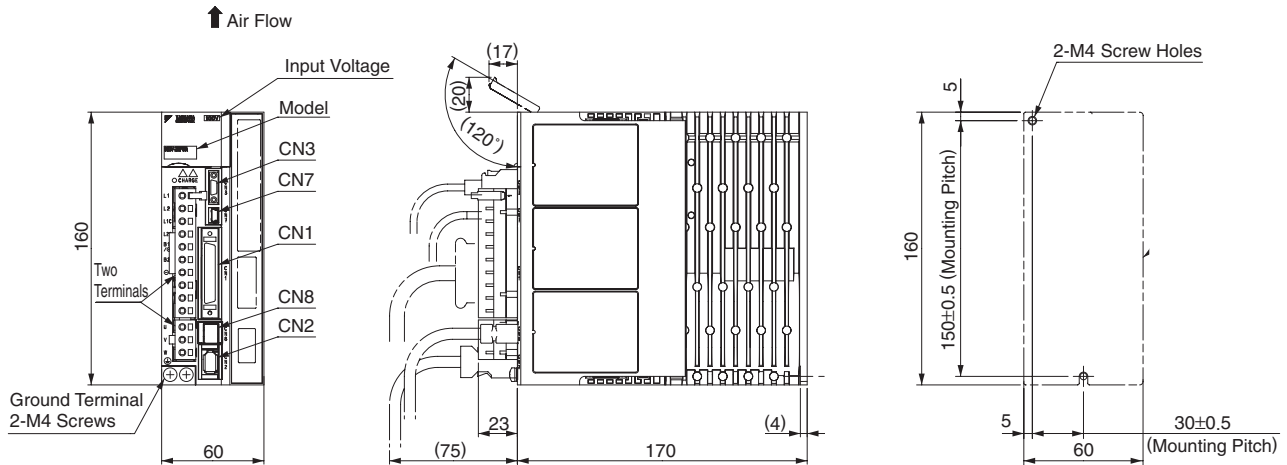

Mounting Hole Diagram

Approx. Mass: 1.1 kg

- (2) Single-phase 100 VAC, Model: SGDV2R8F0□A002000□□□

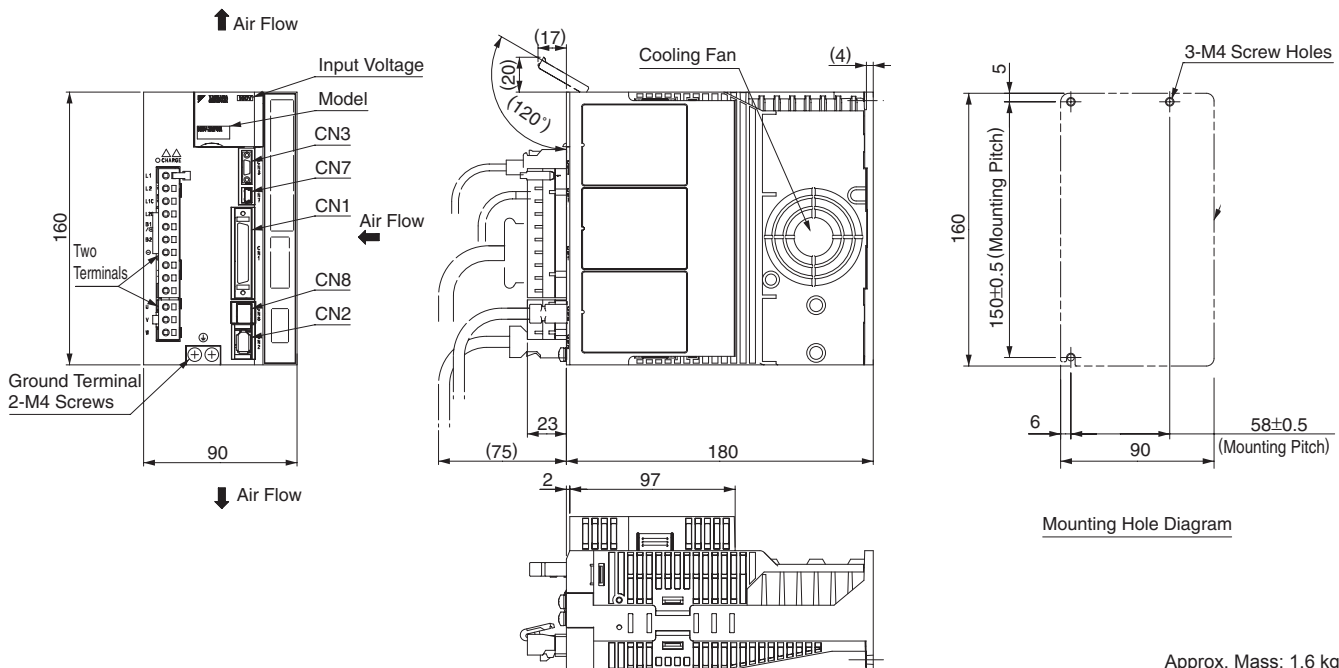

Mounting Hole Diagram

Approx. Mass: 1.6 kg

**External Dimensions** Units: mm (for Analog Voltage/Pulse Train Reference Type SERVOPACKs)

(3) Three-phase 200 VAC, Model: SGDVR70A0□B002000□□□, SGDVR90A0□B002000□□□, and SGDV1R6A0□B002000□□□

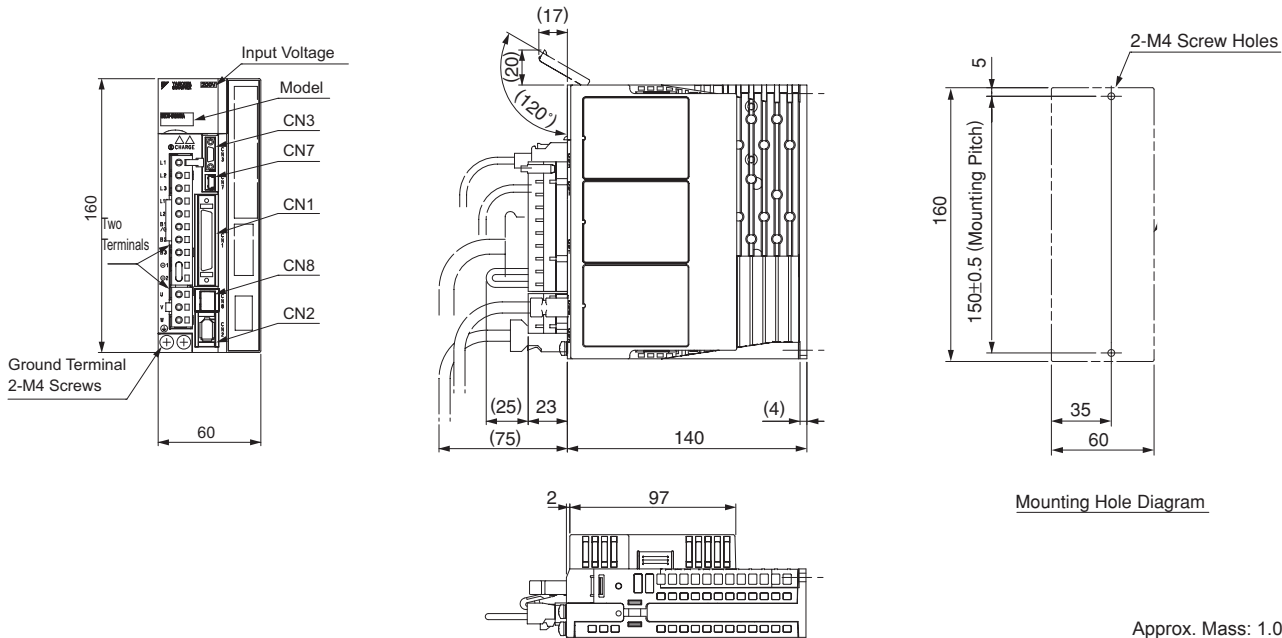

(4) Three-phase 200 VAC, Model: SGDV2R8A0□B002000□□□

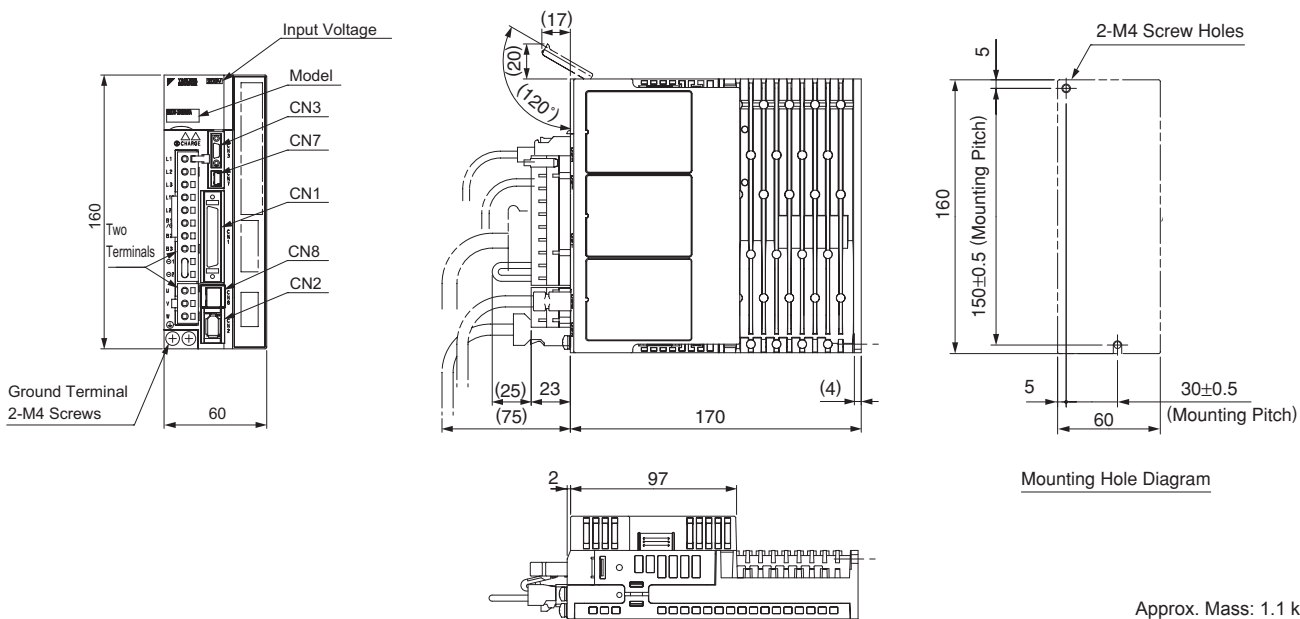

**External Dimensions** Units: mm (for Analog Voltage/Pulse Train Reference Type SERVOPACKs)

(5) Three-phase 200 VAC, Model: SGD V3R8A0□A002000□□□, SGD V5R5A0□A000000□□□, and SGD V7R6A0□A002000□□□

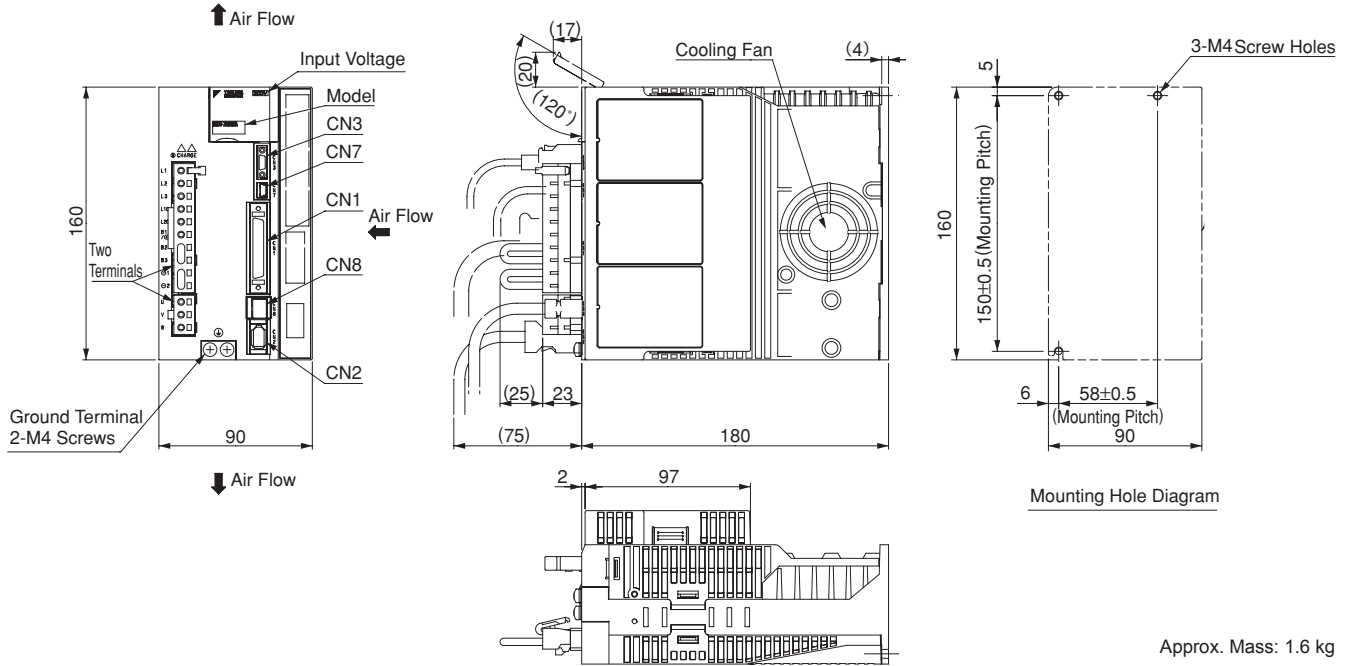

(6) Three-phase 200 VAC, Model: SGD V120A0□A002000□□□

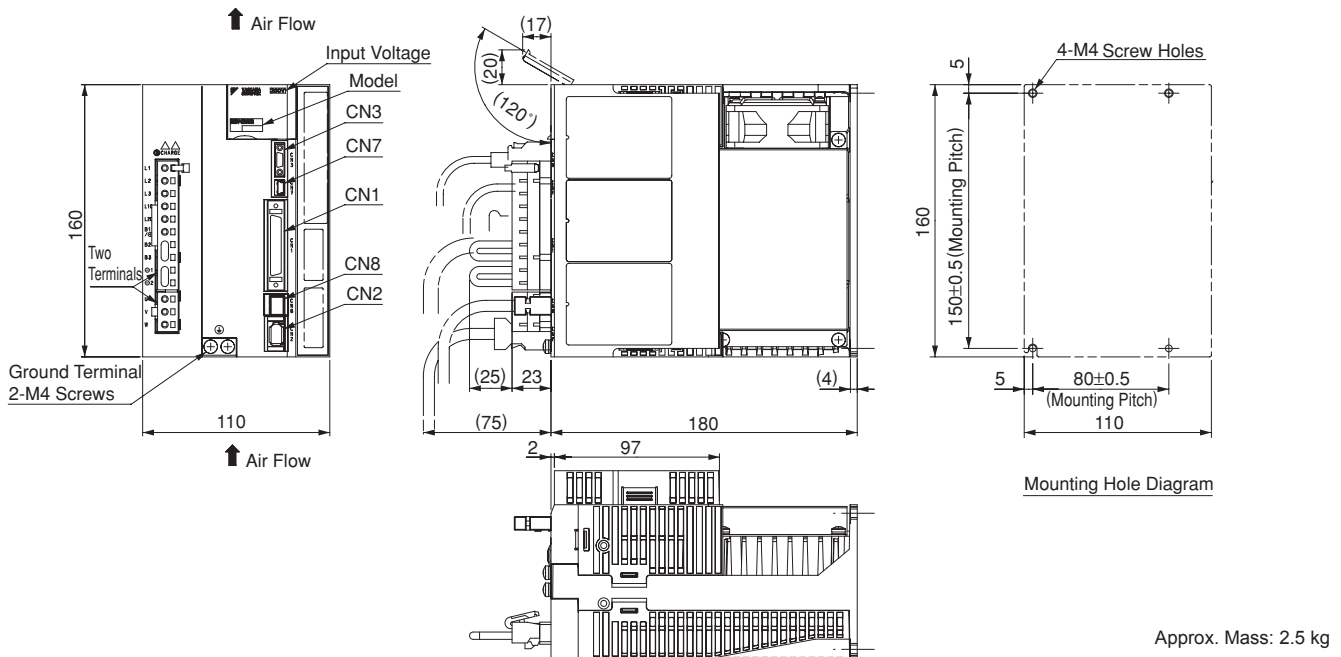

External Dimensions Units: mm (for Analog Voltage/Pulse Train Reference Type SERVOPACKs)

- (7) Single-phase 200 VAC, Model: SGDV120A0□A008000□□□ (1.5 kW, single-phase input type)  
 Three-phase 200 VAC, Model: SGDV180A0□A002000□□□, and SGDV200A0□A002000□□□

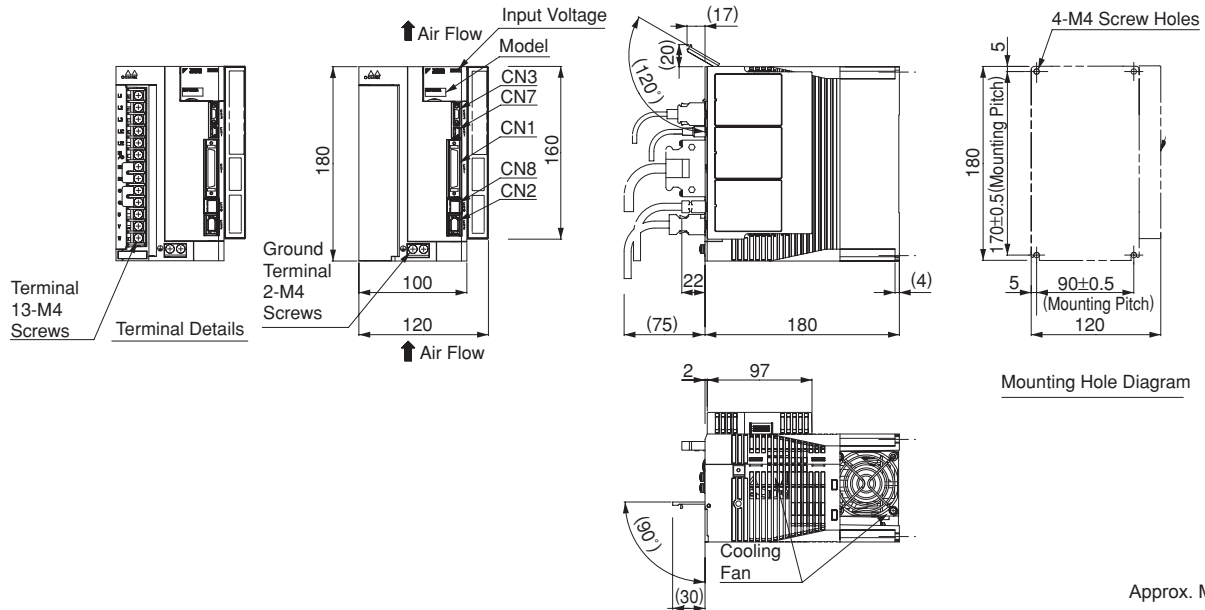

- (8) Three-phase 200 VAC, Model: SGDV330A0□A002000□□□

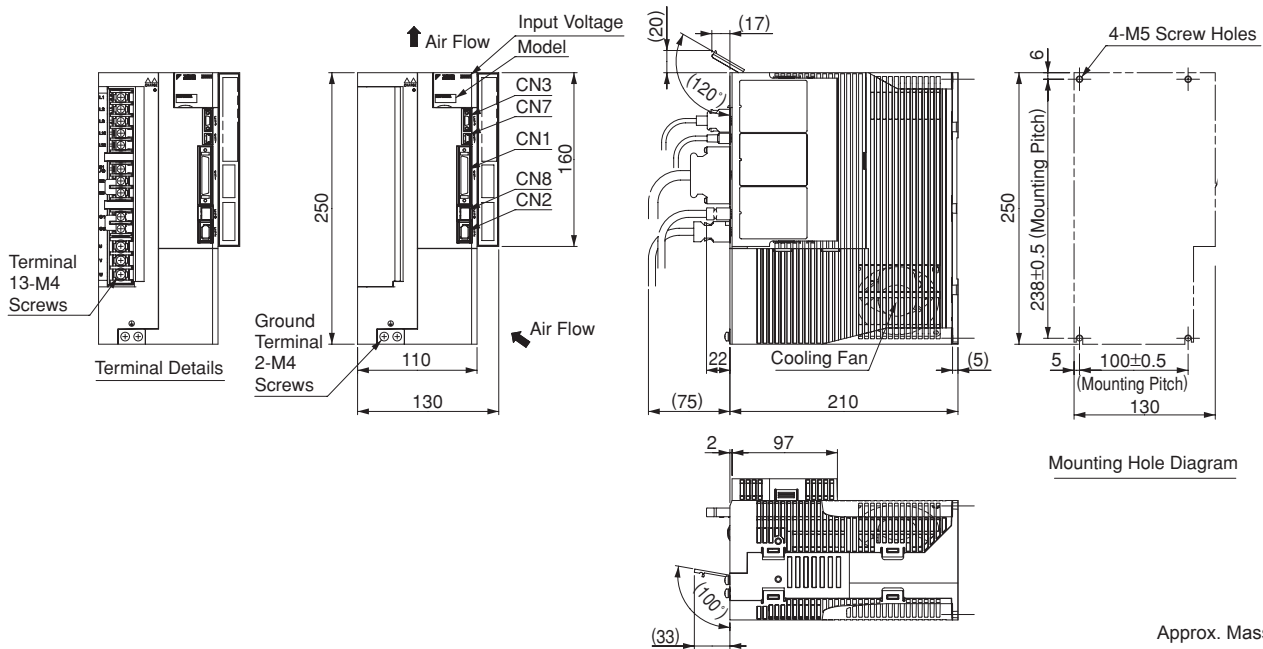

**External Dimensions** Units: mm (for Analog Voltage/Pulse Train Reference Type SERVOPACKs)

(9) Three-phase 200 VAC, Model: SGDV470A0□A002000□□□, SGDV550A0□A000000□□□

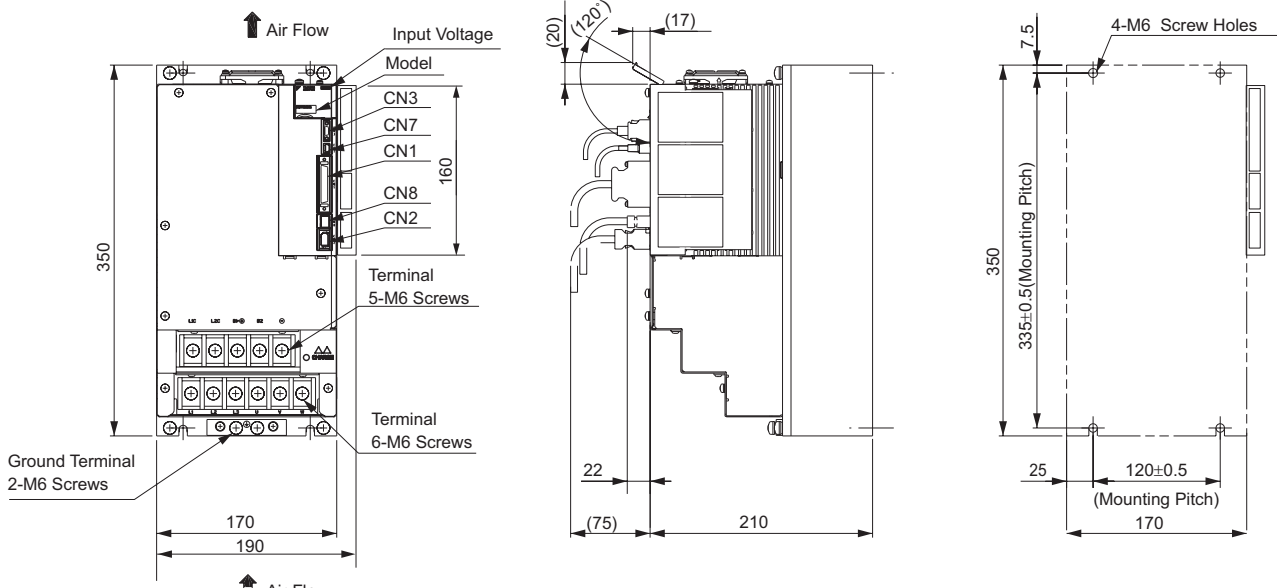

Approx. Mass: 1.6 kg

(10) Three-phase 200 VAC, Model: SGDV590A0□A002000□□□, SGDV780A0□A002000□□□

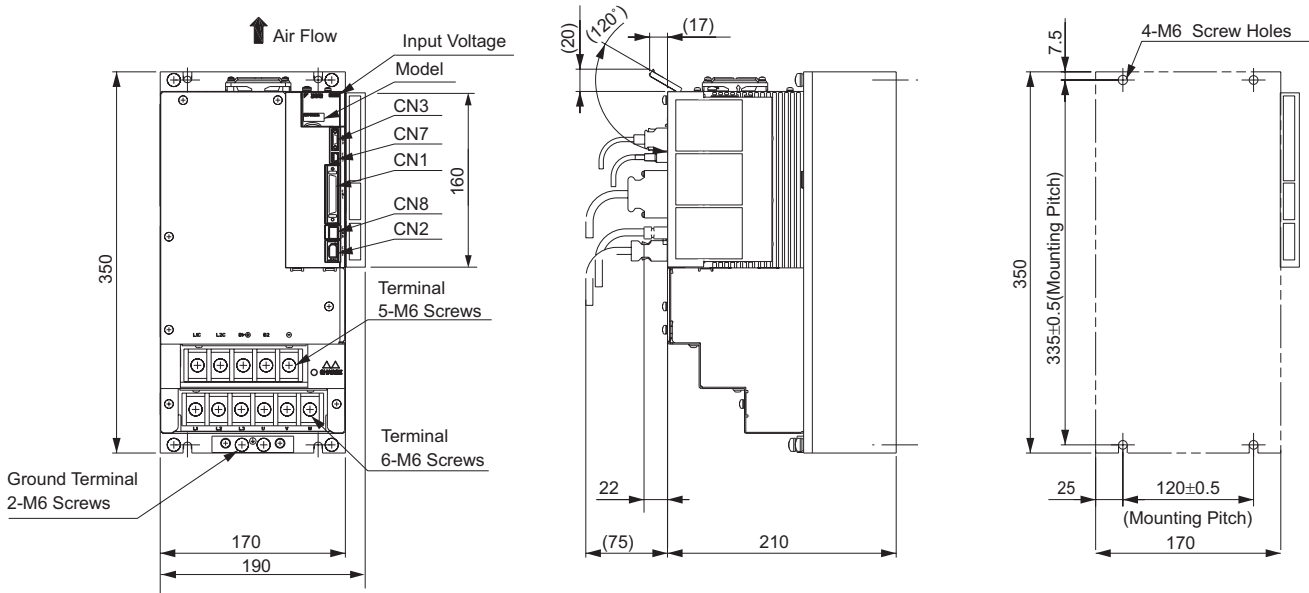

Approx. Mass: 2.5 kg



External Dimensions Units: mm (for Analog Voltage/Pulse Train Reference Type SERVOPACKs)

(11) Three-phase 400 VAC, Model: SGDV1R9D0□A002000□□□, 3R5D0□A002000□□□, and 5R4D0□A002000□□□

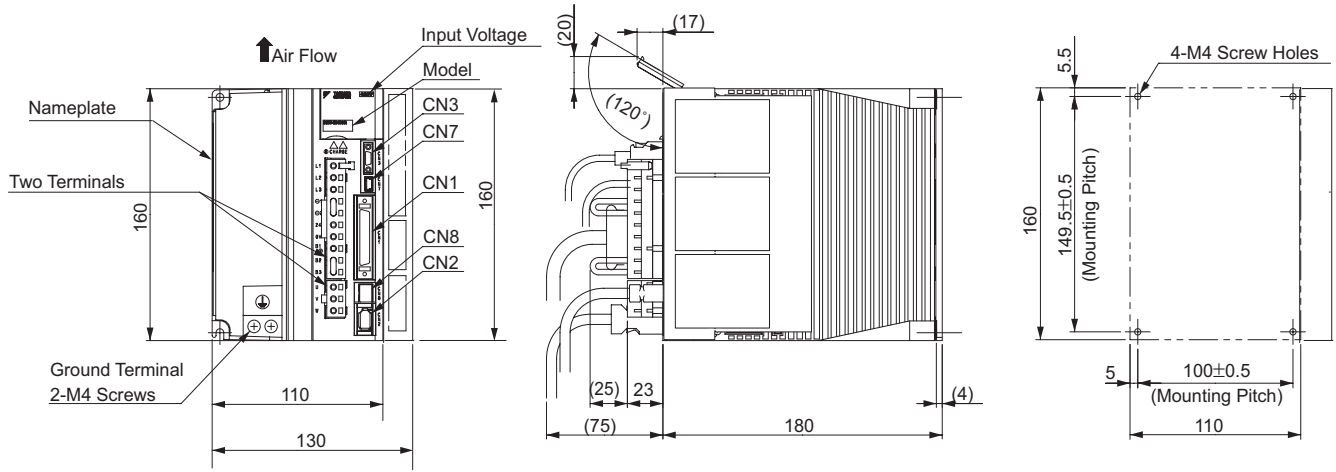

Approx. Mass: 2.7 kg

(12) Three-phase 400 VAC, Model: SGDV8R4D0□A002000□□□ and 120D0□A002000□□□,

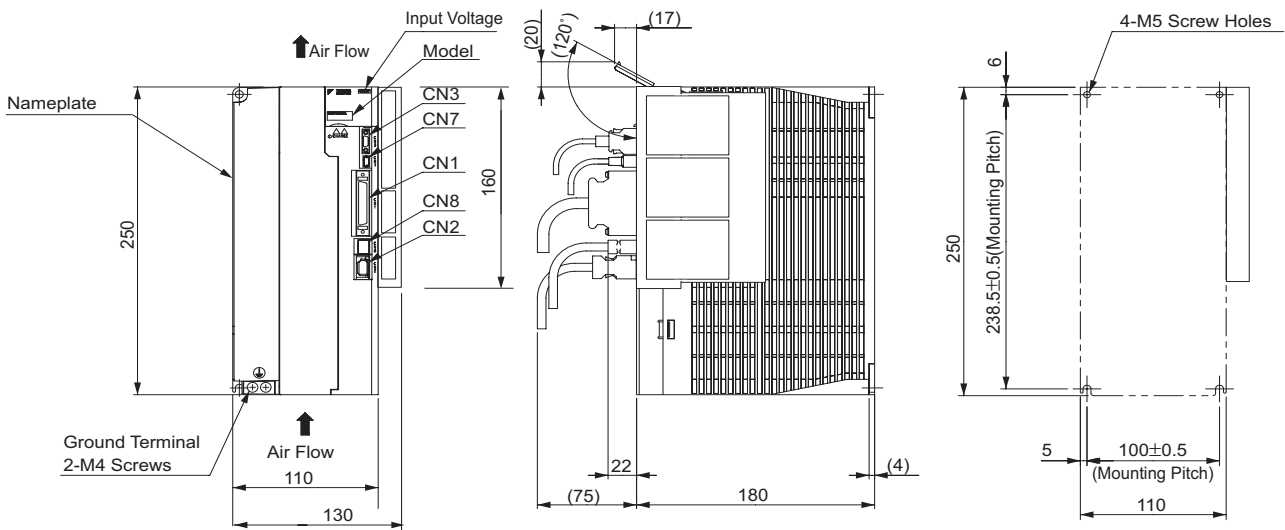

Approx. Mass: 3.7 kg

(13) Three-phase 400 VAC, Model: SGDV170D0□A002000□□□

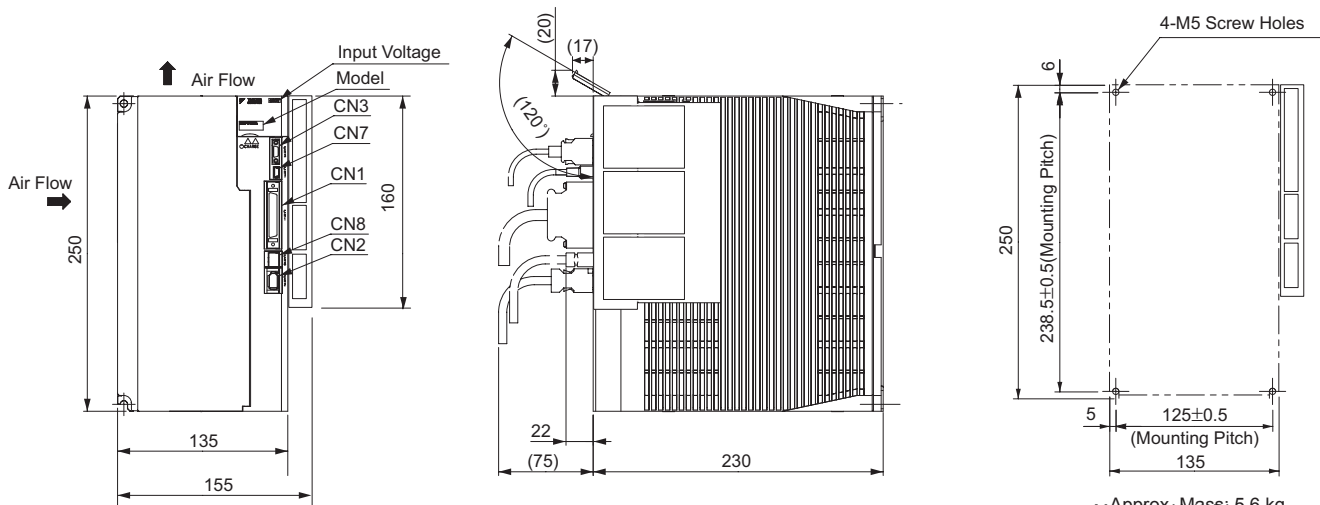

Approx. Mass: 5.6 kg

## External Dimensions Units: mm (for Analog Voltage/Pulse Train Reference Type SERVOPACKs)

(14) Three-phase 400 VAC, Model: SGDV210D0□A002000□□□□ and 260D0□A002000□□□□

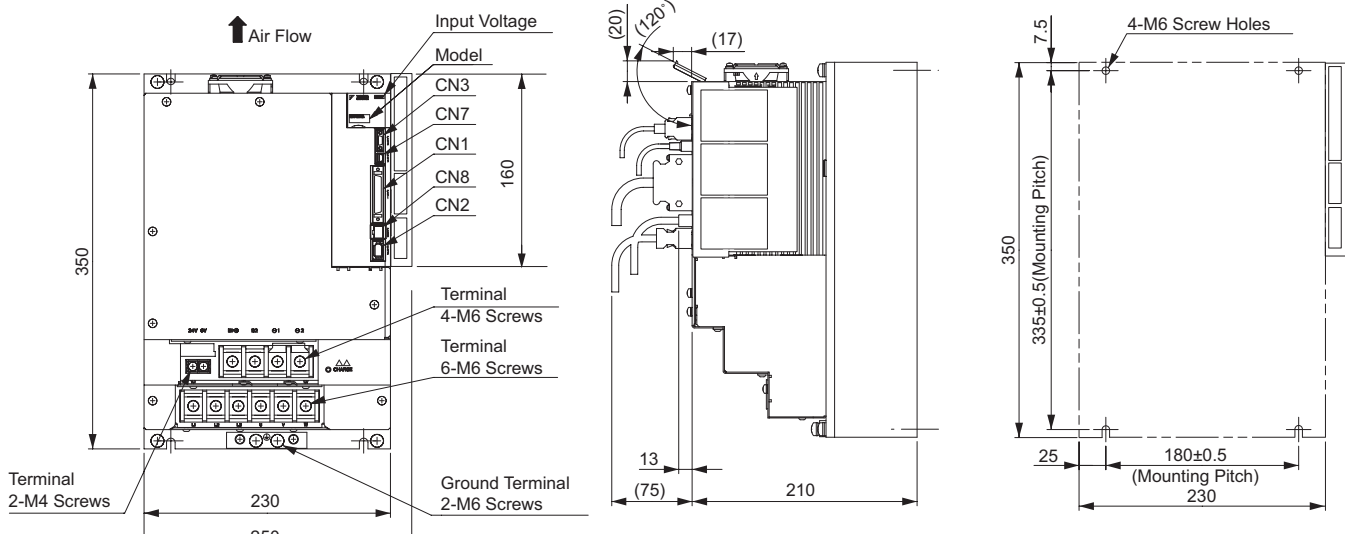

Approx. Mass: 11.3 kg

(15) Three-phase 400 VAC, Model: SGDV280D0□A002000□□□□ and 370D0□A002000□□□□

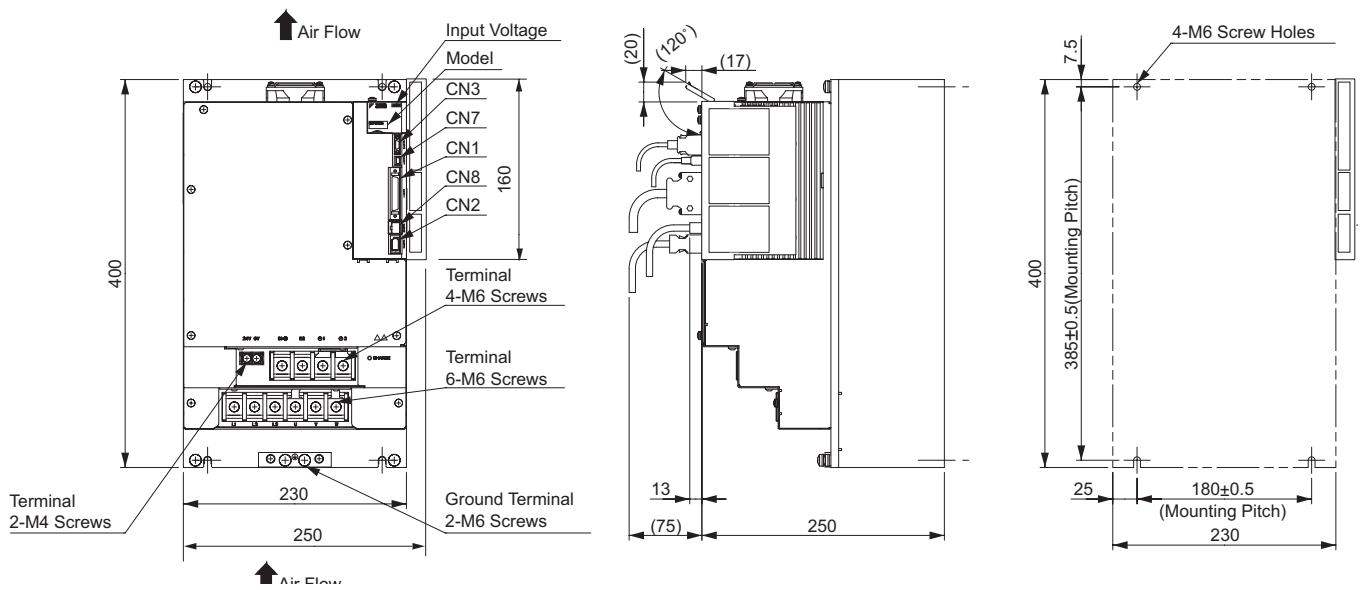

Approx. Mass: 16.2 kg

## Connectors for Base-mounted SERVOPACKs

Port	Model	Pin	Manufacturer
CN1	10250-52A2PL	50	Sumitomo 3M Ltd.
CN2	53984-0671	6	Molex Japan Co., Ltd.
CN3	HDR-EC14LFDTN-SLE-PLUS	14	Honda Tsushin Kogyo Co., Ltd.
CN7	MNC23-5K5H00	5	ADVANCED-CONNECTEK INC.
CN8	1981080-1	8	Tyco Electronics AMP K.K.

Note: The connectors above or their equivalents are used for SERVOPACKs.

External Dimensions Units: mm (for MECHATROLINK-II Communications Reference Type SERVOPACKS)

● Base-mounted SERVOPACKS

- (1) Single-phase 100 VAC, Model: SGDVR70F1□A000000□□□□, SGDVR90F1□A002000□□□□, and SGDV2R1F1□A002000□□□□

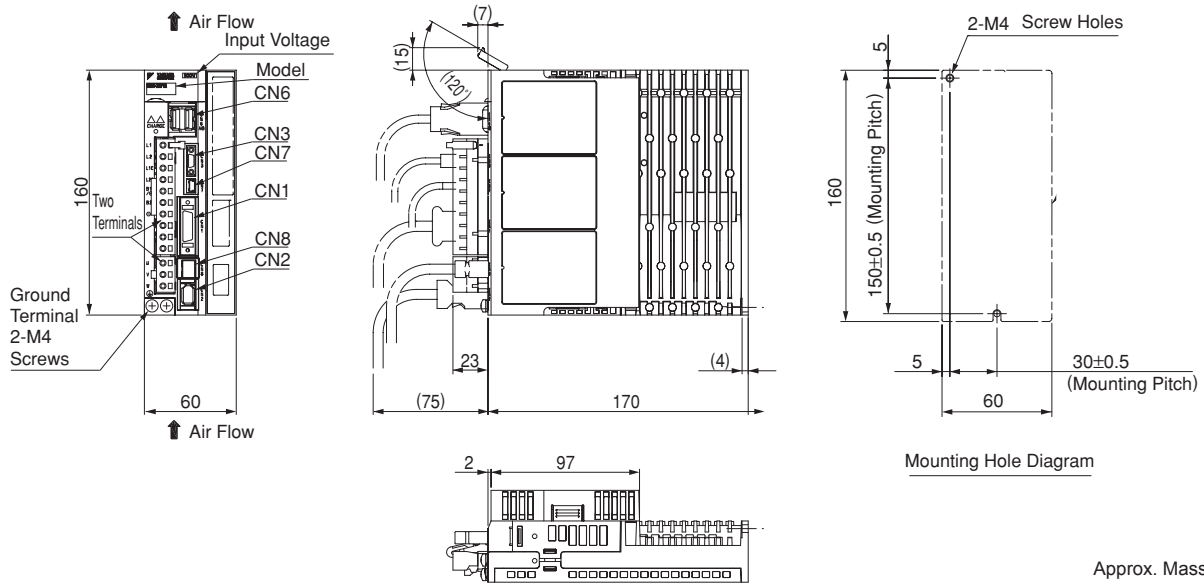

Approx. Mass: 1.1 kg

- (2) Single-phase 100 VAC, Model: SGDV2R8F1□A002000□□□□

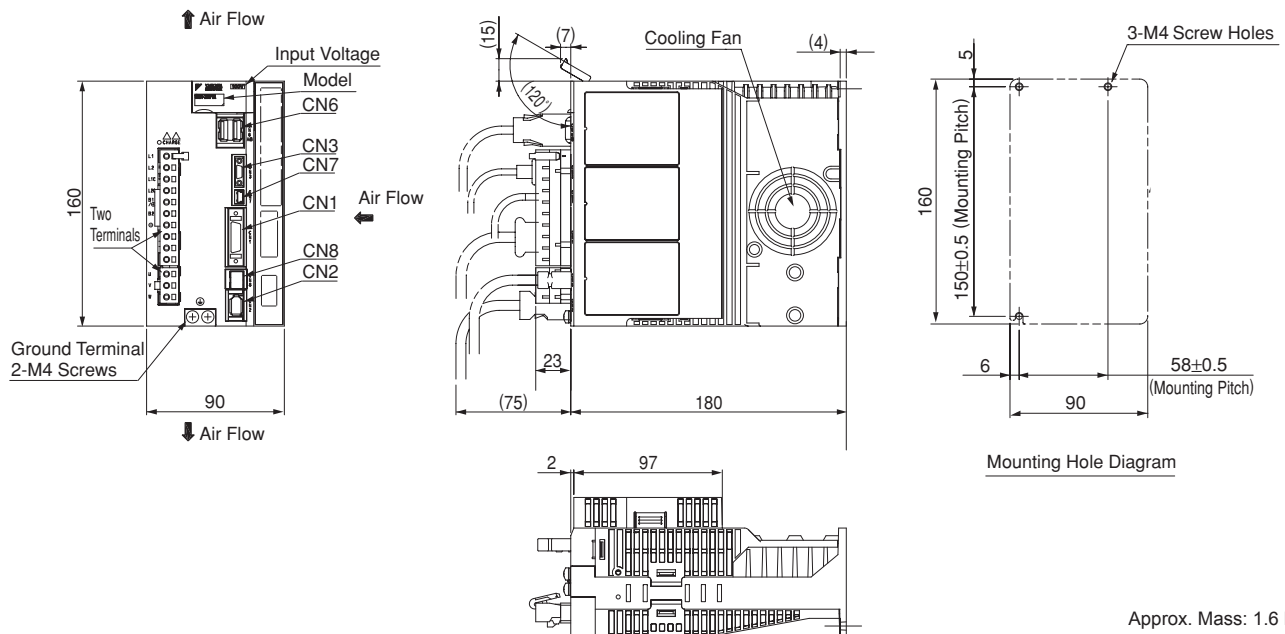

Approx. Mass: 1.6 kg

External Dimensions Units: mm (for MECHATROLINK-II Communications Reference Type SERVOPACKs)

(3) Three-phase 200 VAC, Model: SGDV-R70A1□B00200□□□, SGDV-R90A1□B00200□□□, and SGDV1R6A1□B00200□□□

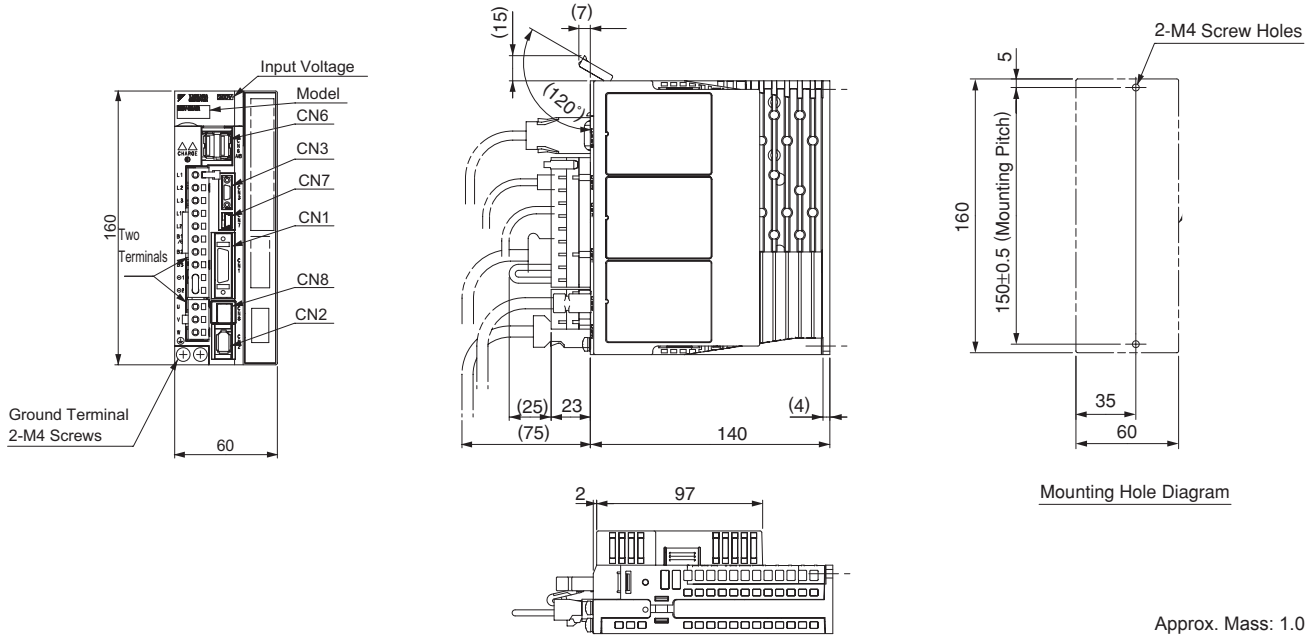

(4) Three-phase 200 VAC, Model: SGDV2R8A1□B00200□□□

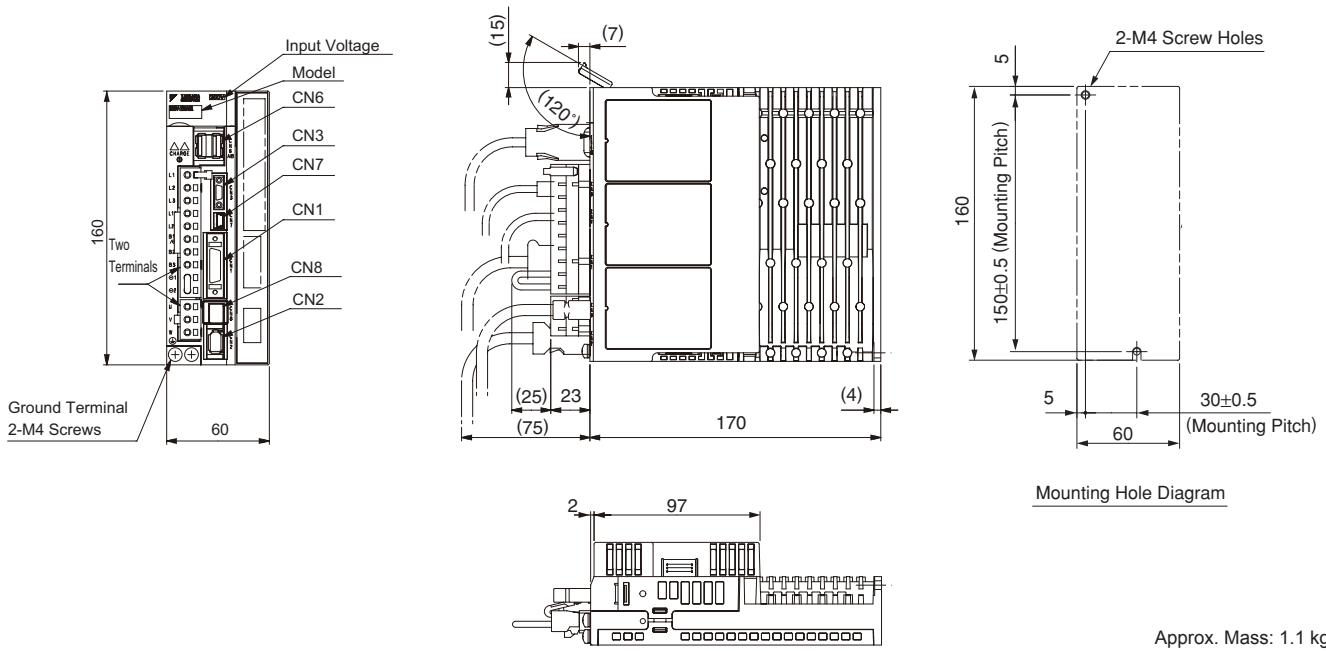

External Dimensions Units: mm (for MECHATROLINK-II Communications Reference Type SERVOPACKs)

(5) Three-phase 200 VAC, Model: SGDV3R8A1□A002000□□□, SGDV5R5A1□A002000□□□, and SGDV7R6A1□A002000□□□

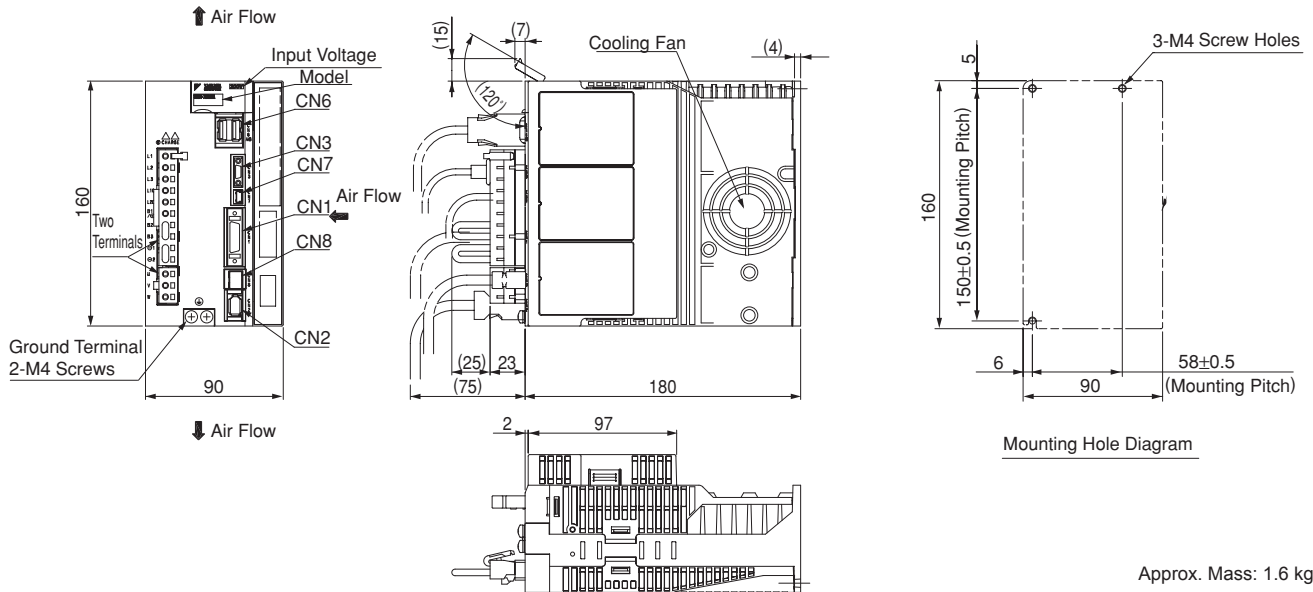

(6) Three-phase 200 VAC, Model: SGDV120A1□A002000□□□

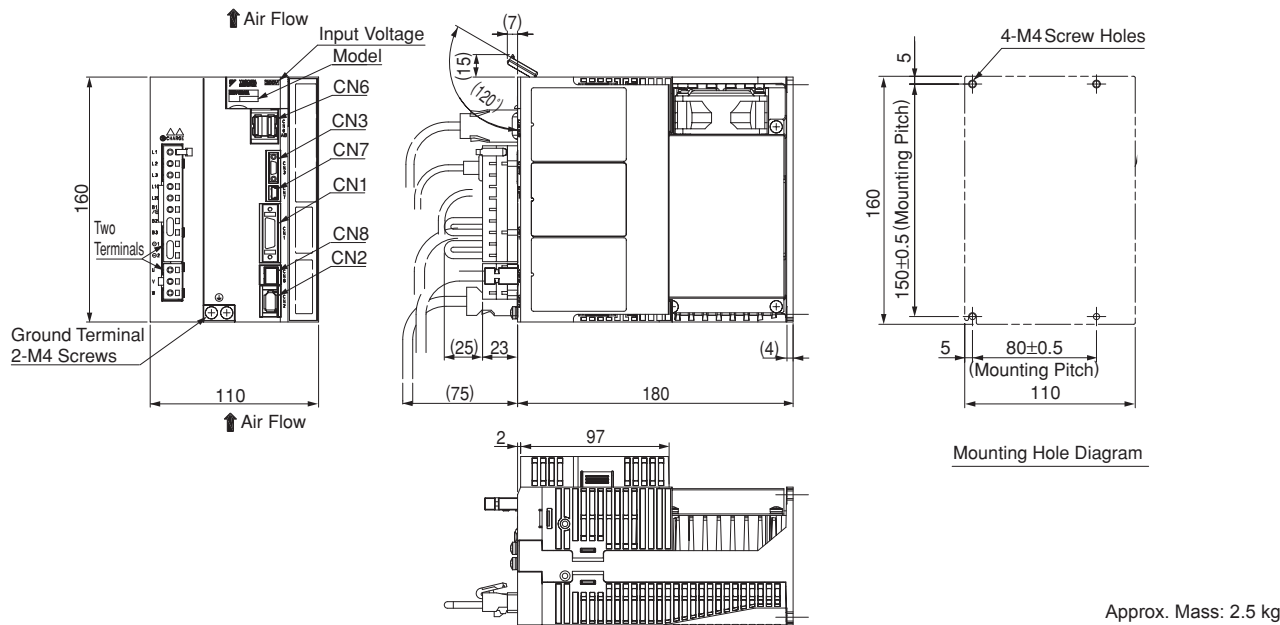

External Dimensions Units: mm (for MECHATROLINK-II Communications Reference Type SERVOPACKs)

- (7) Single-phase 200 VAC, Model: SGDV120A1□A008000□□□ (1.5 kW, single-phase input type)
- Three-phase 200 VAC, Model: SGDV180A1□A002000□□□, and SGDV200A1□A002000□□□

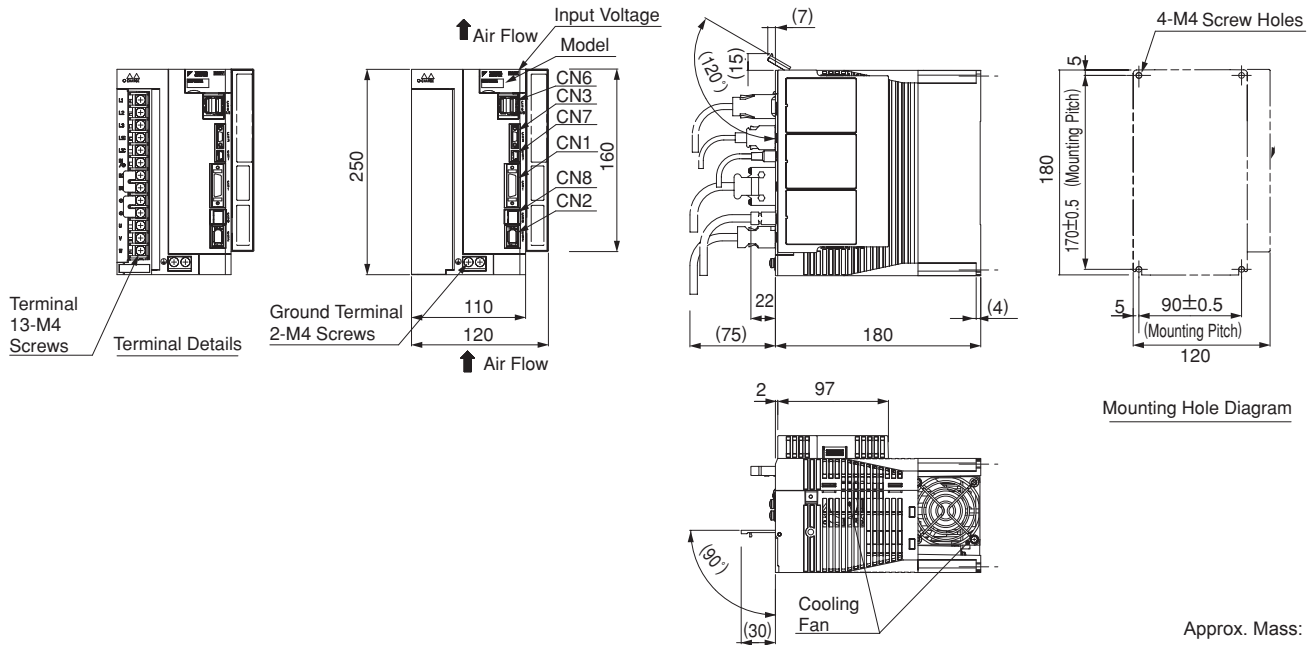

- (8) Three-phase 200 VAC, Model: SGDV330A1□A002000□□□

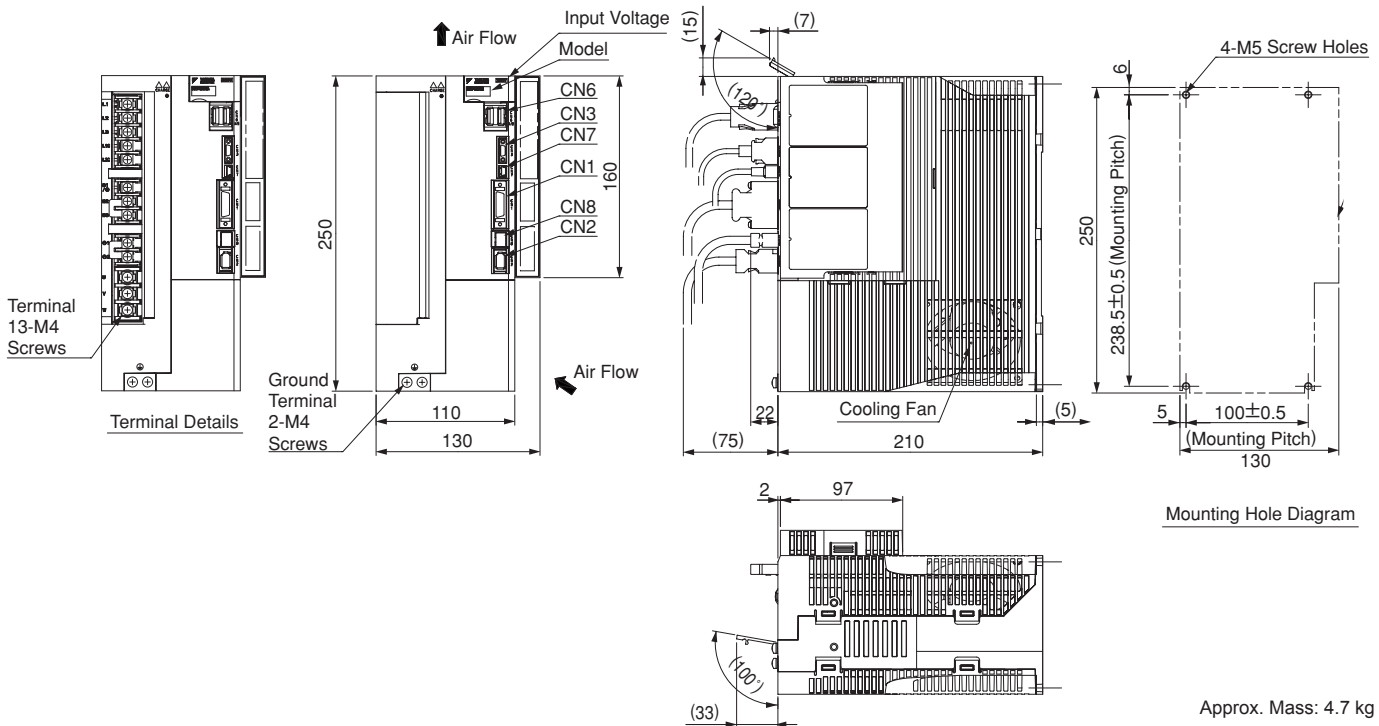

External Dimensions Units: mm (for MECHATROLINK-II Communications Reference Type SERVOPACKs)

(9) Three-phase 200 VAC, Model: SGD V470A1□A00200□□□, SGD V550A1□A00200□□□

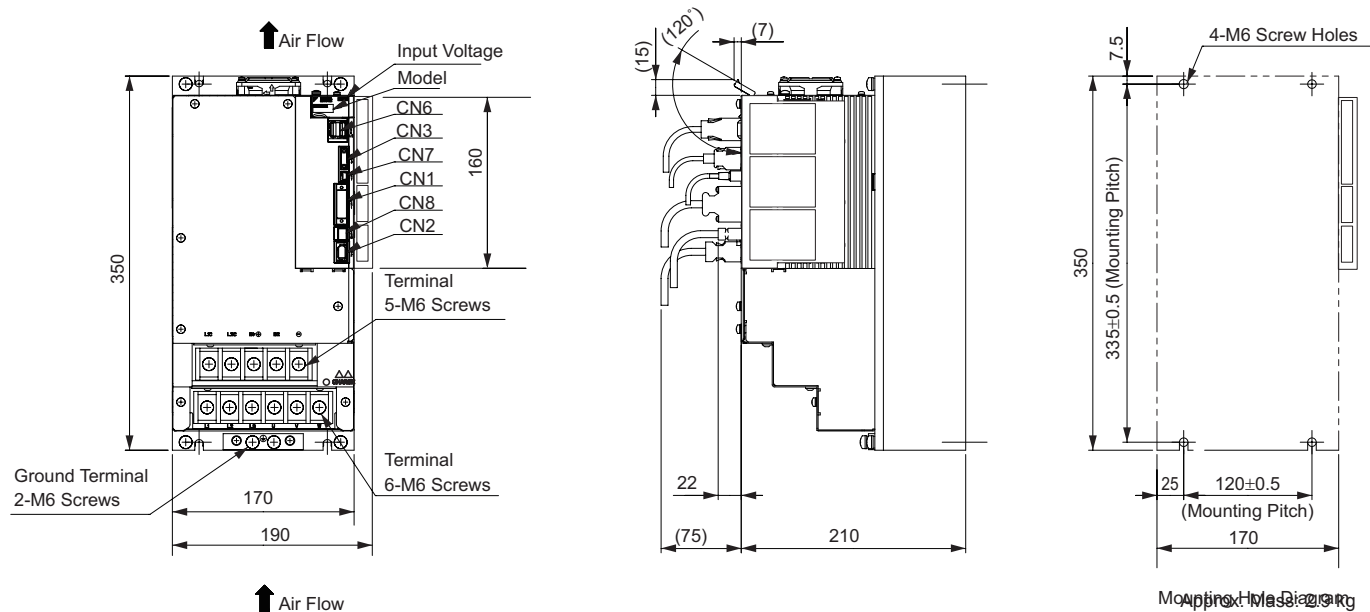

(10) Three-phase 200 VAC, Model: SGD V590A1□A00200□□□, SGD V780A1□A00200□□□

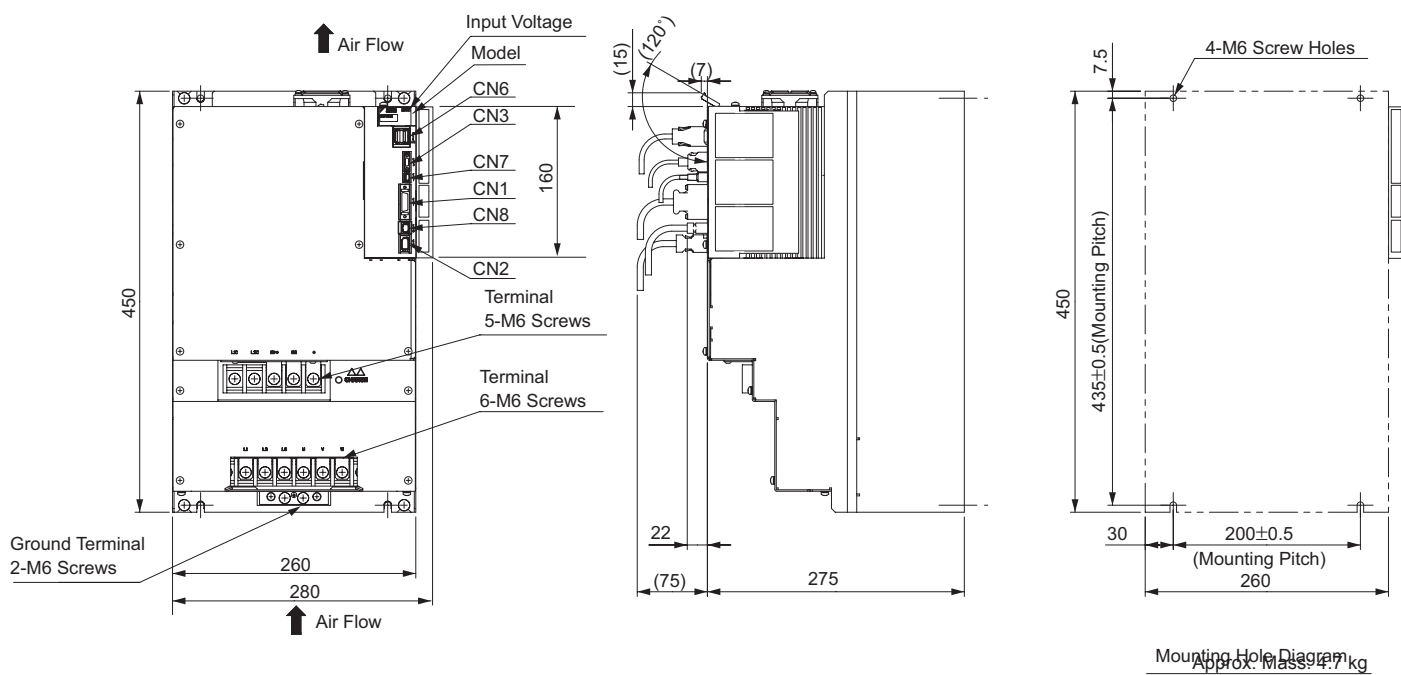

External Dimensions Units: mm (for MECHATROLINK-II Communications Reference Type SERVOPACKs)

(11) Three-phase 400 VAC, Model: SGD1V1R9D1□A002000□□□, 3R5D1□A000000□□□, and 5R4D1□A000000□□□

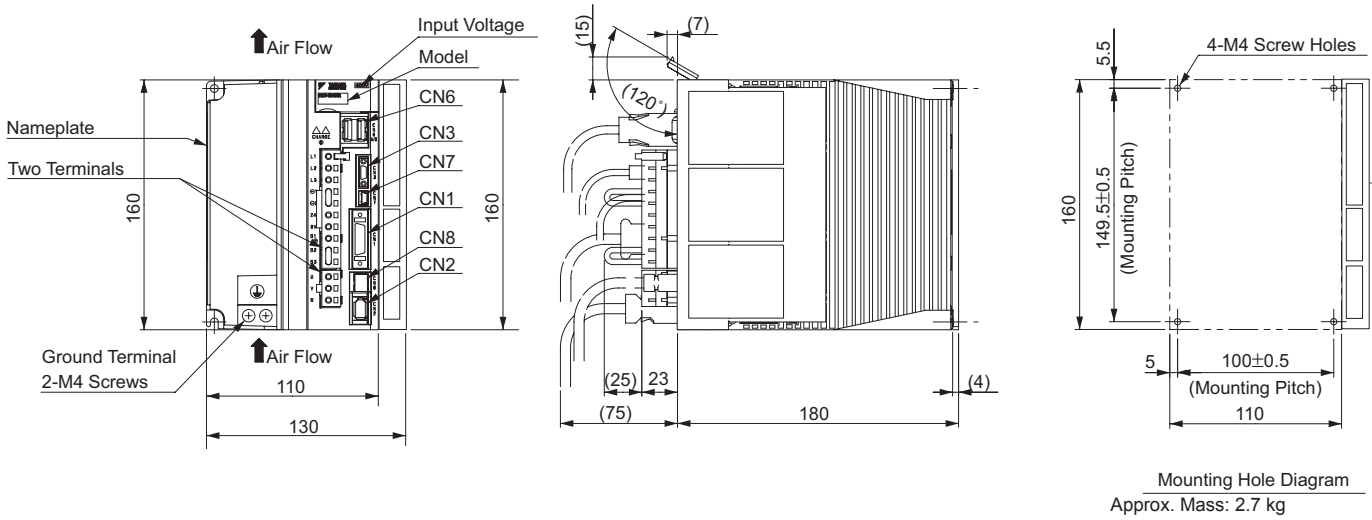

(12) Three-phase 400 VAC, Model: SGD1V8R4D1□A002000□□□ and 120D1□A000000□□□,

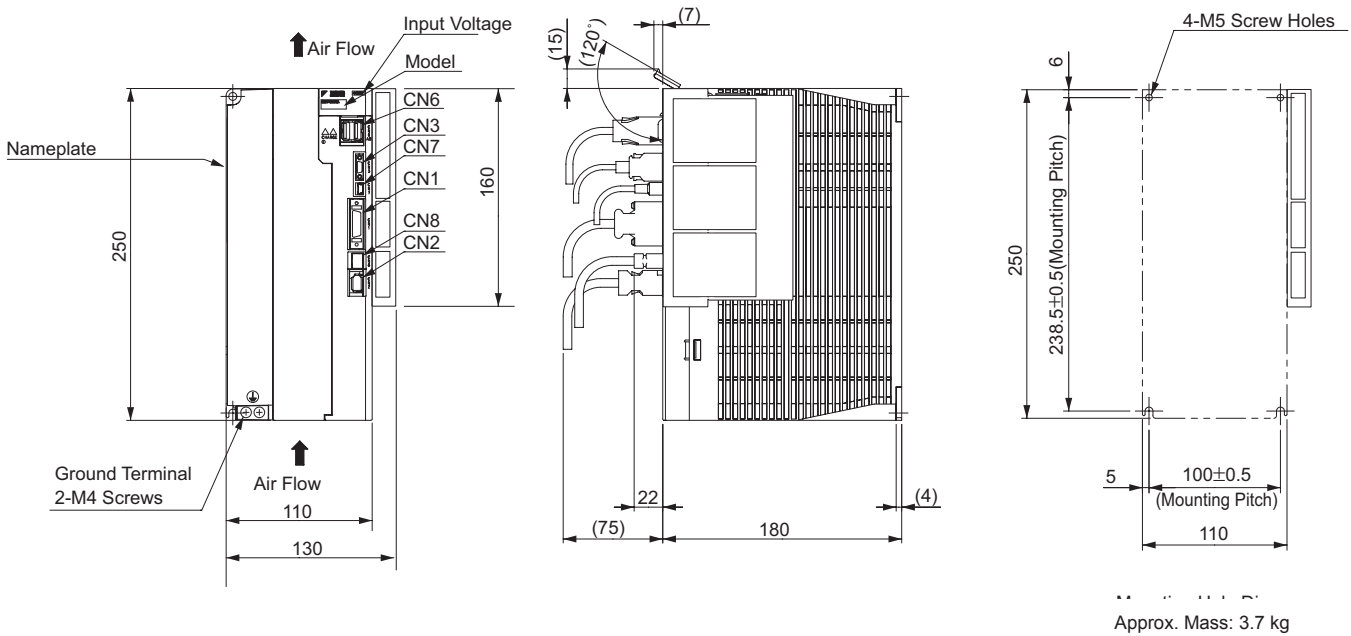



External Dimensions Units: mm (for MECHATROLINK-II Communications Reference Type SERVOPACKs)

(13) Three-phase 400 VAC, Model: SGDV170D1□A00200□□□

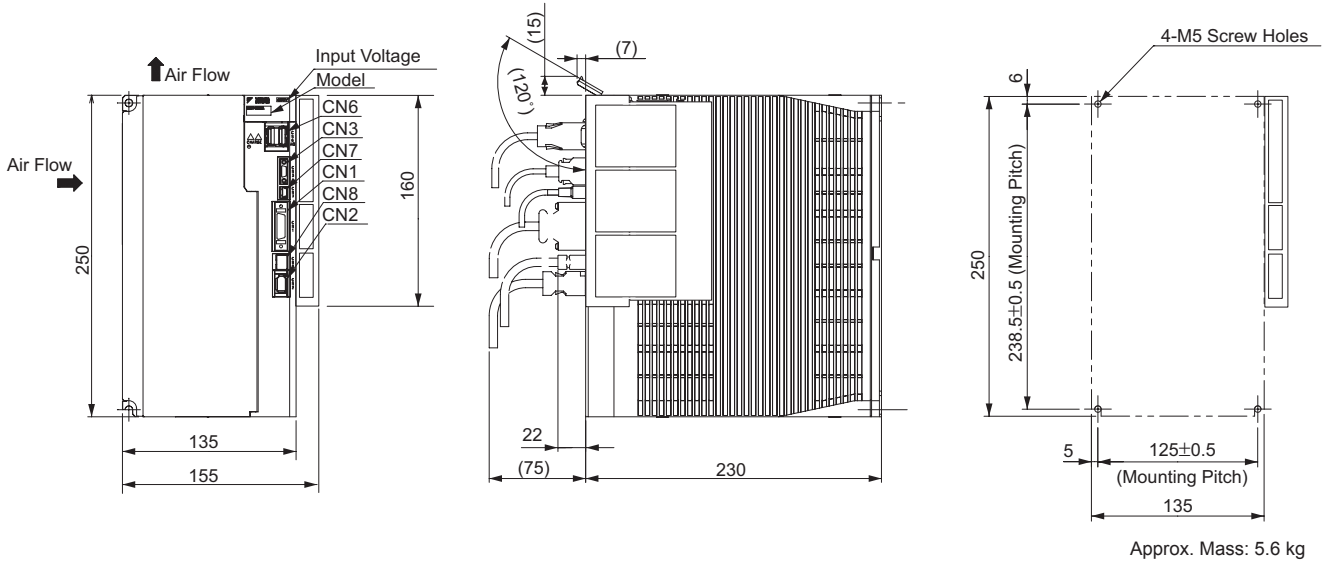

(14) Three-phase 400 VAC, Model: SGDV210D1□A00200□□□ and 260D1□A00200□□□

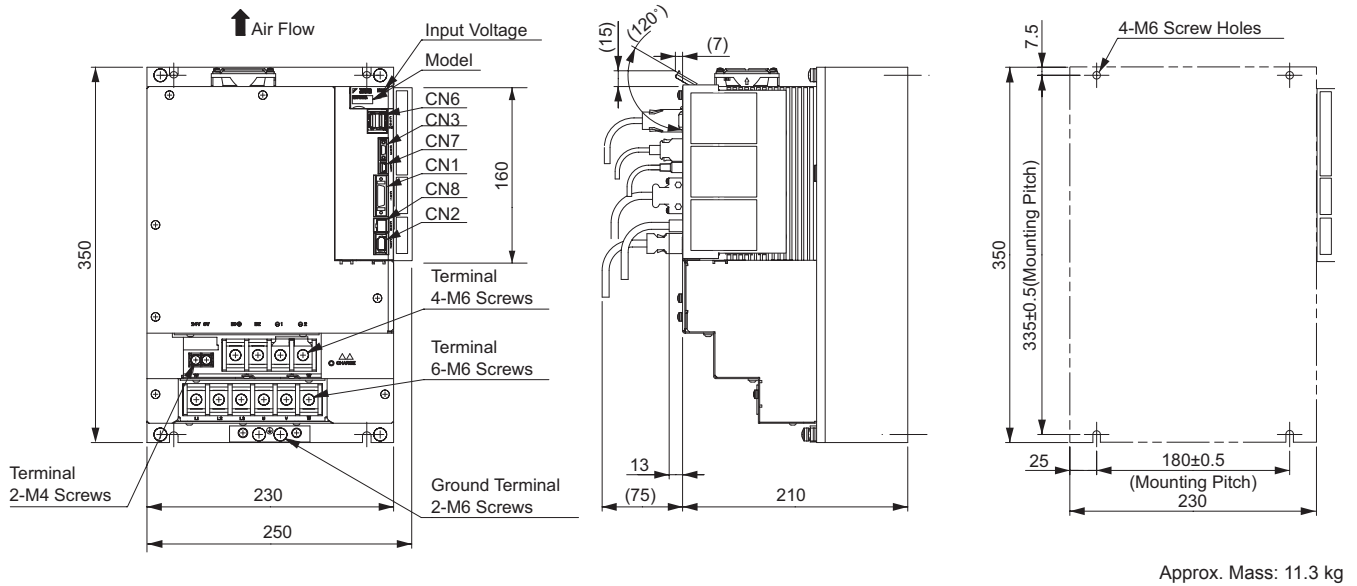

External Dimensions Units: mm (for MECHATROLINK-II Communications Reference Type SERVOPACKs)

(15) Three-phase 400 VAC, Model: SGDV280D1□A00200□□□ and 370D1□A000000□□□

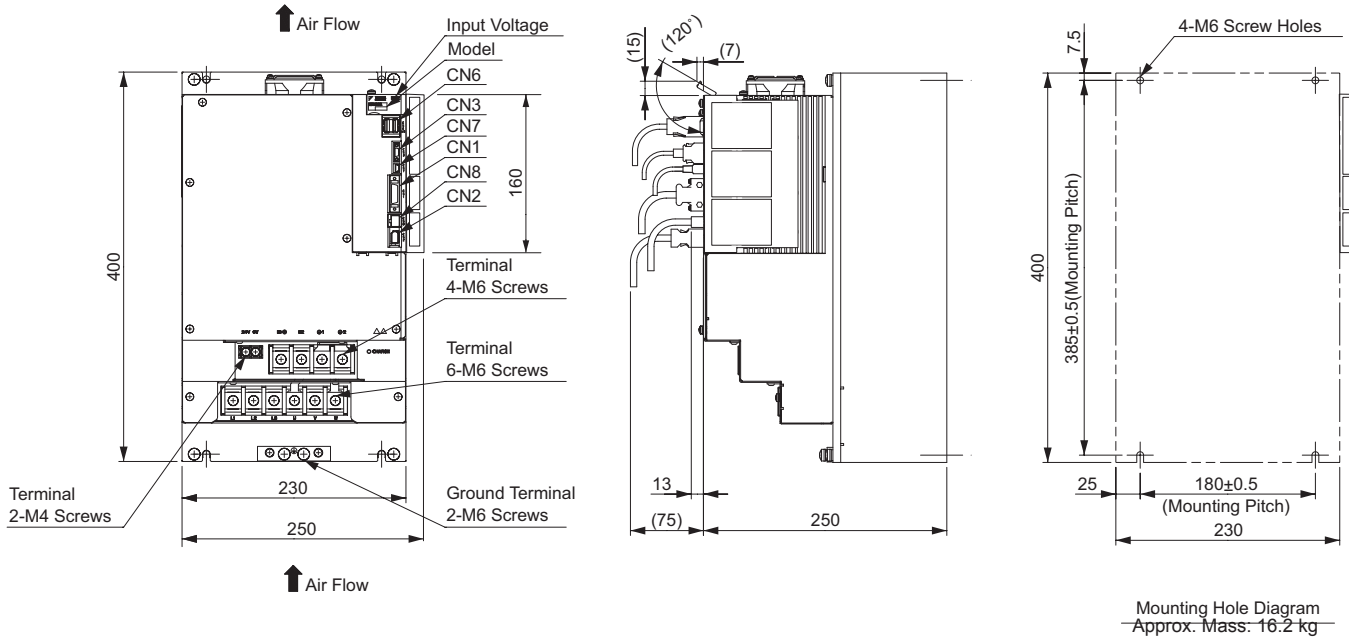

Connectors for Base-mounted SERVOPACKs

Port	Model	Pin	Manufacturer
CN1	10226-52A2PL	26	Sumitomo 3M Ltd.
CN2	53984-0671	6	Molex Japan Co., Ltd.
CN3	HDR-EC14LFDTN-SLE-PLUS	14	Honda Tsushin Kogyo Co., Ltd.
CN6	1903815-1	8	Tyco Electronics AMP K.K.
CN7	MNC23-5K5H00	5	ADVANCED-CONNECTEK INC.
CN8	1981080-1	8	Tyco Electronics AMP K.K.

Note: The connectors above or their equivalents are used for SERVOPACKs.

**External Dimensions** Units: mm (for Other Control Architecture Type SERVOPACKs)

The following drawings illustrate the external dimensions of SERVOPACKs with Interface Option E with option modules.

● **Base-mounted SERVOPACKs**

- (1) Single-phase 100 VAC, Model: SGDVR70FE□A00200□□□, SGDVR90FE□A00200□□□, and SGDVR2R1FE□A00200□□□

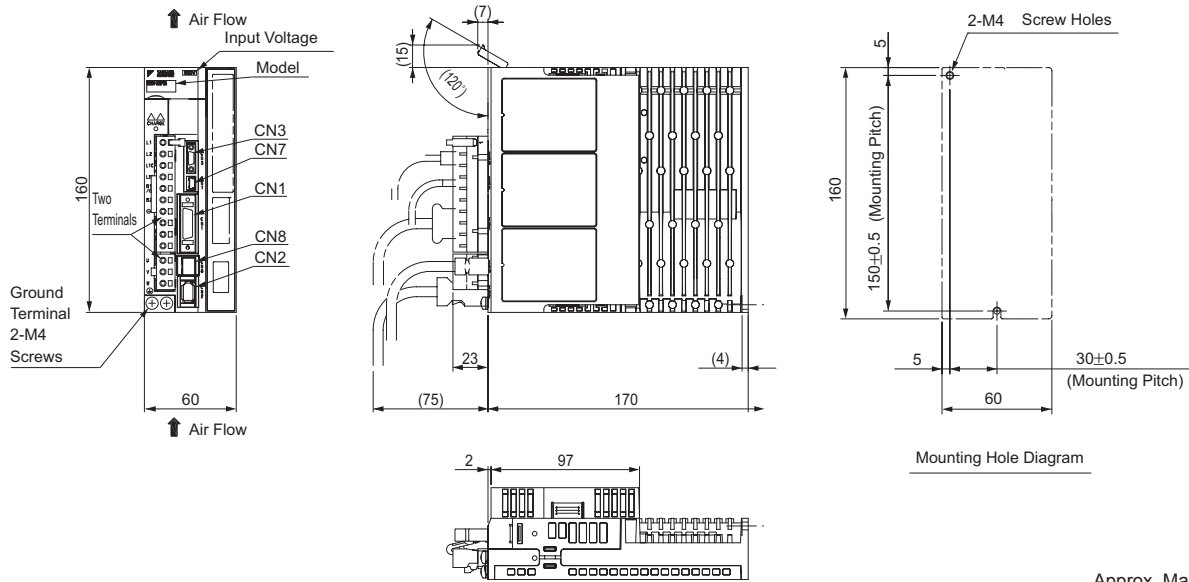

Approx. Mass: 1.1 kg

- (2) Single-phase 100 VAC, Model: SGDVR2R8FE□A000200□□□

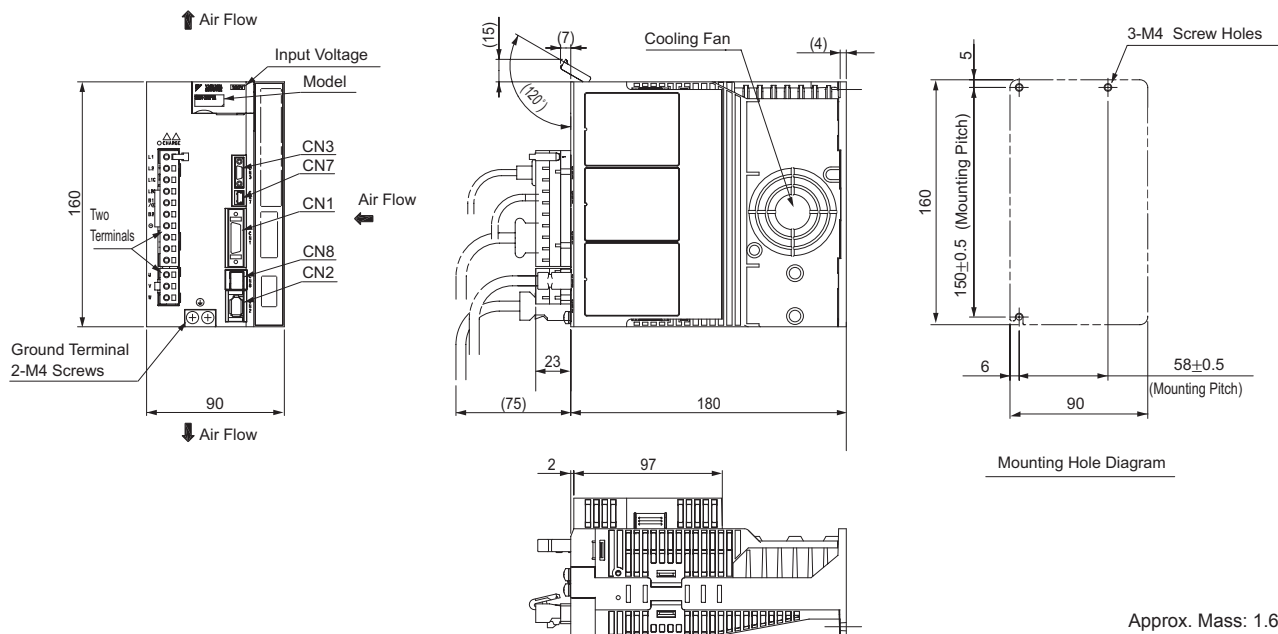

Approx. Mass: 1.6 kg

External Dimensions Units: mm (for Other Control Architecture Type SERVOPACKs)

(3) Three-phase 200 VAC, Model: SGDV-R70AE□A002000□□□, SGDV-R90AE□A002000□□□, and SGDV1R6AE□A002000□□□

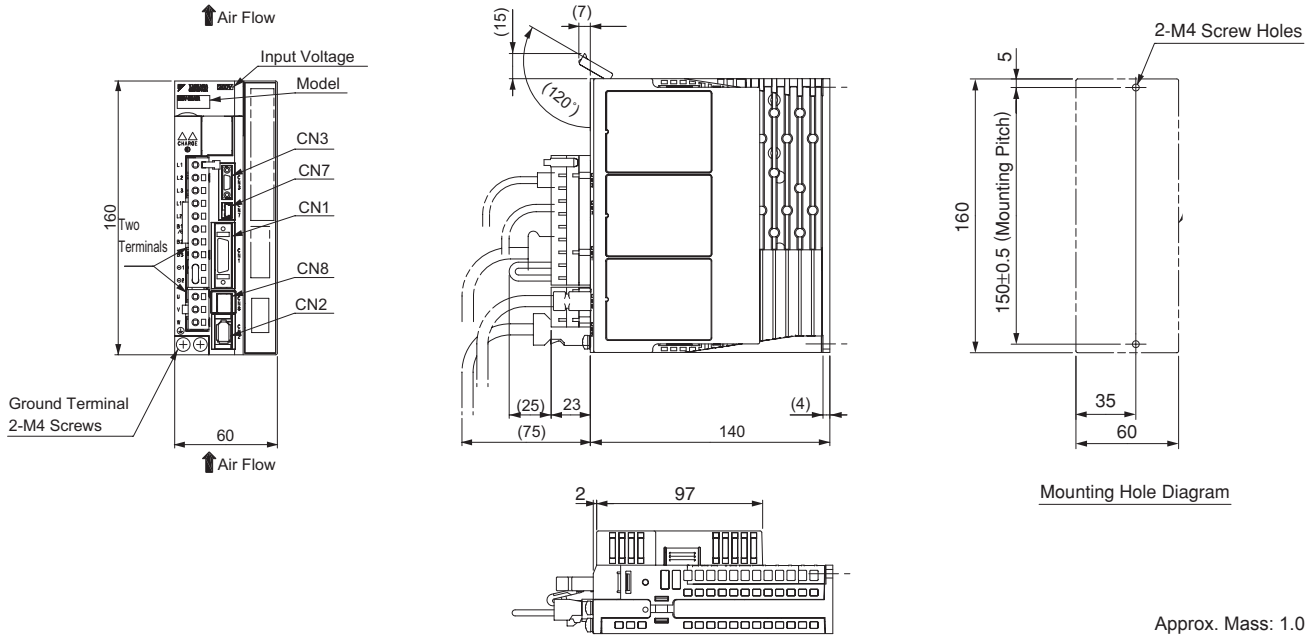

(4) Three-phase 200 VAC, Model: SGDV2R8AE□A002000□□□

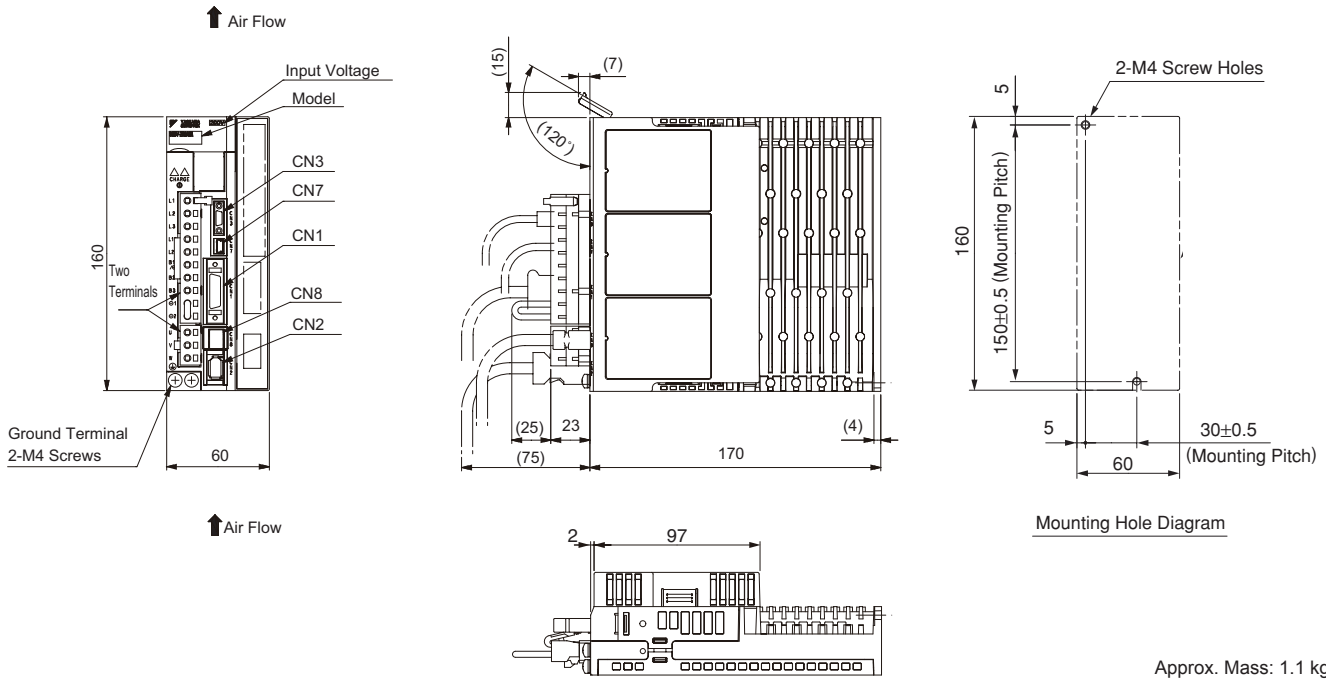

External Dimensions Units: mm (for Other Control Architecture Type SERVOPACKs)

(5) Three-phase 200 VAC, Model: SGDV3R8AE□A00200□□□, SGDV5R5AE□A00200□□□, and SGDV7R6AE□A00200□□□

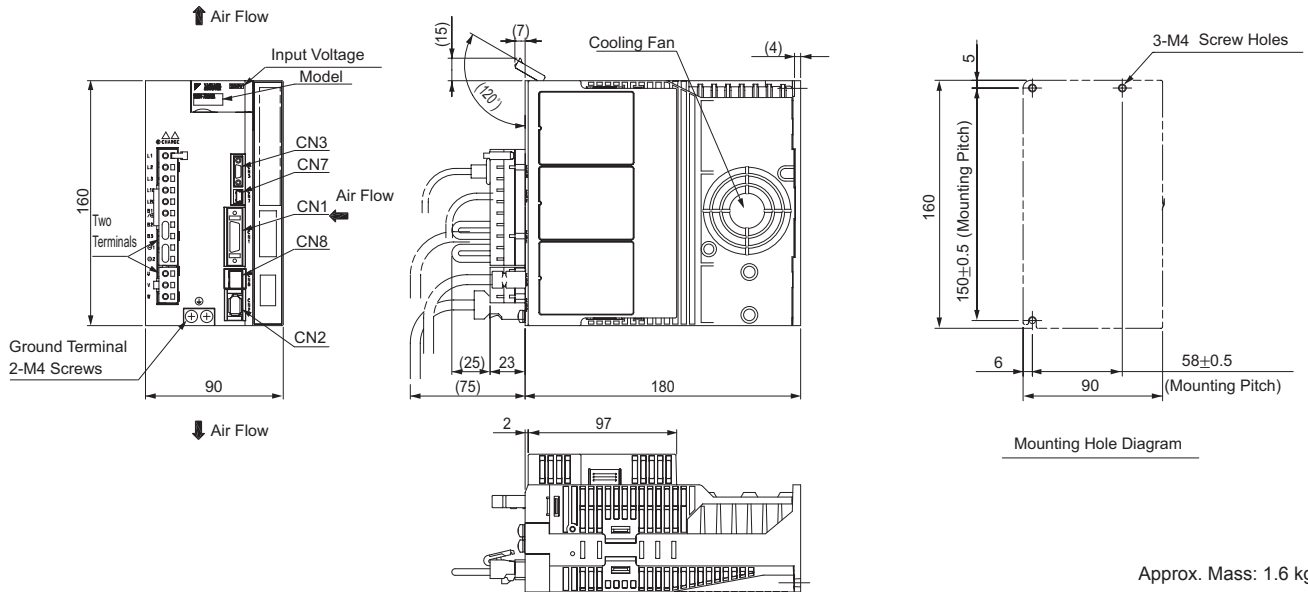

(6) Three-phase 200 VAC, Model: SGDV120AE□A00200□□□

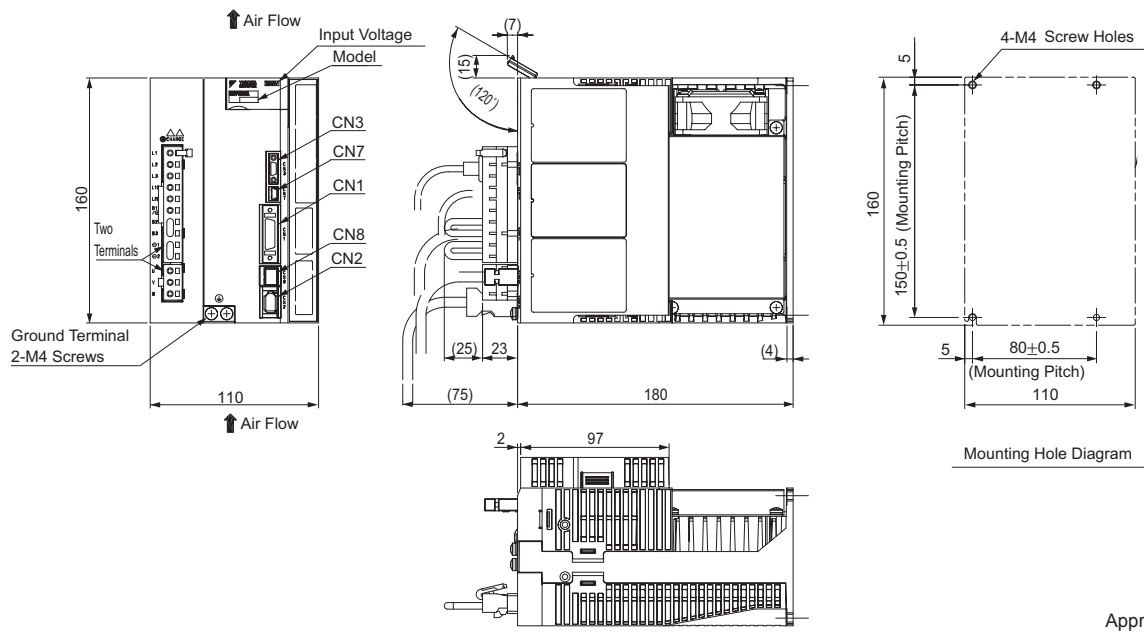

External Dimensions Units: mm (for Other Control Architecture Type SERVOPACKs)

- (7) Single-phase 200 VAC, Model: SGDV120AE□A008000□□□ (1.5 kW, single-phase input type)  
 Three-phase 200 VAC, Model: SGDV180AE□A002000□□□, and SGDV200AE□A002000□□□

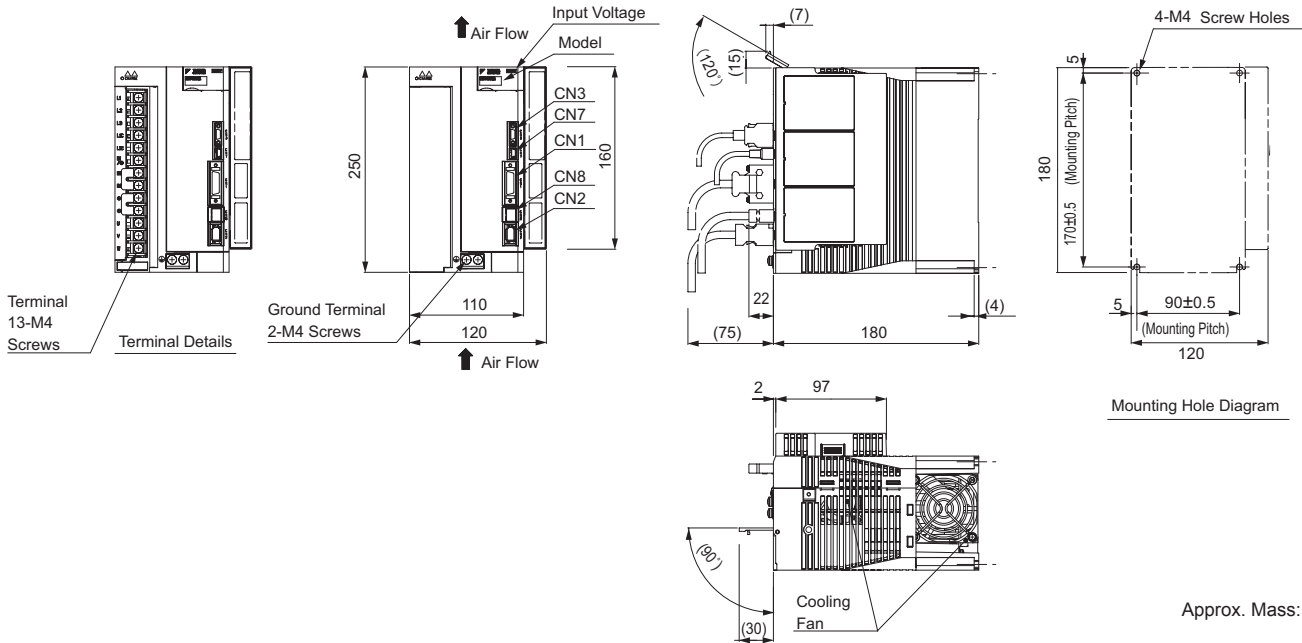

- (8) Three-phase 200 VAC, Model: SGDV330AE□A000000□□□

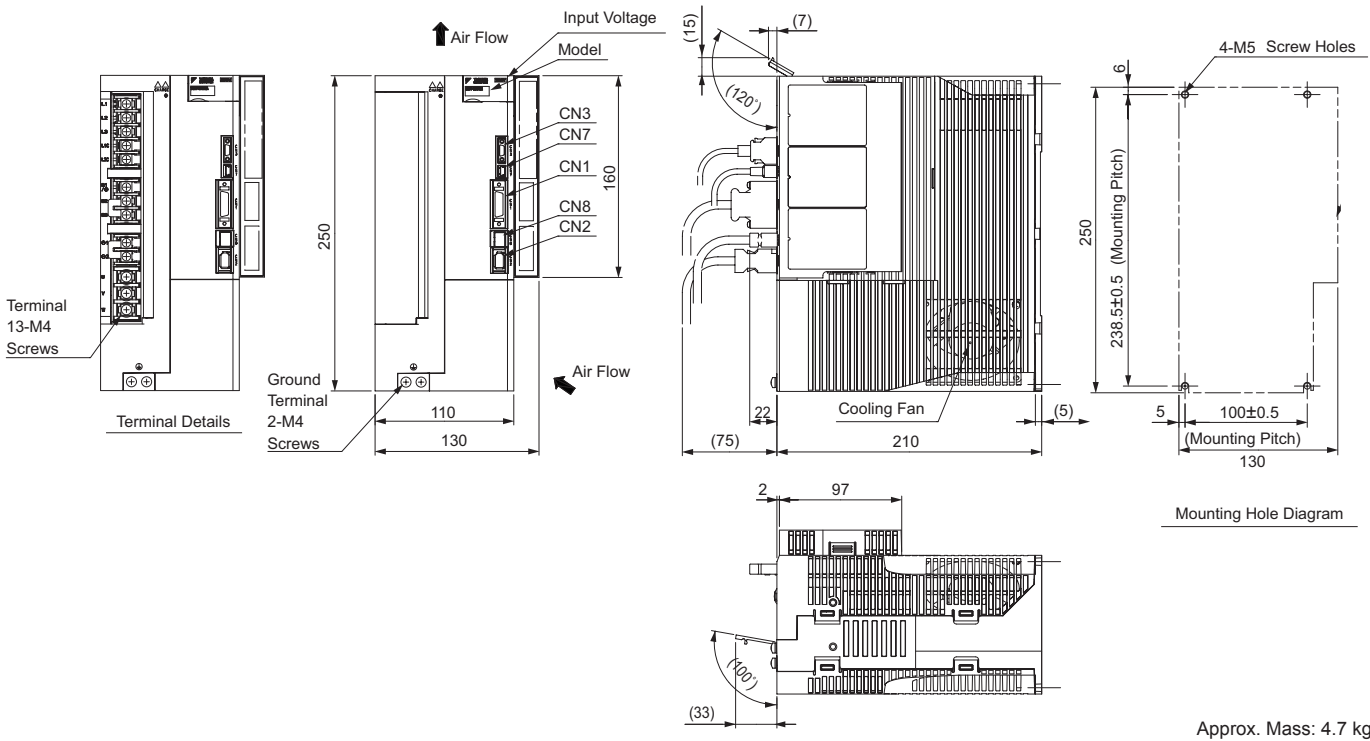

External Dimensions Units: mm (for Other Control Architecture Type SERVOPACKs)

(9) Three-phase 200 VAC, Model: SGD V470AE□A002000□□□, SGD V550AE□A002000□□□

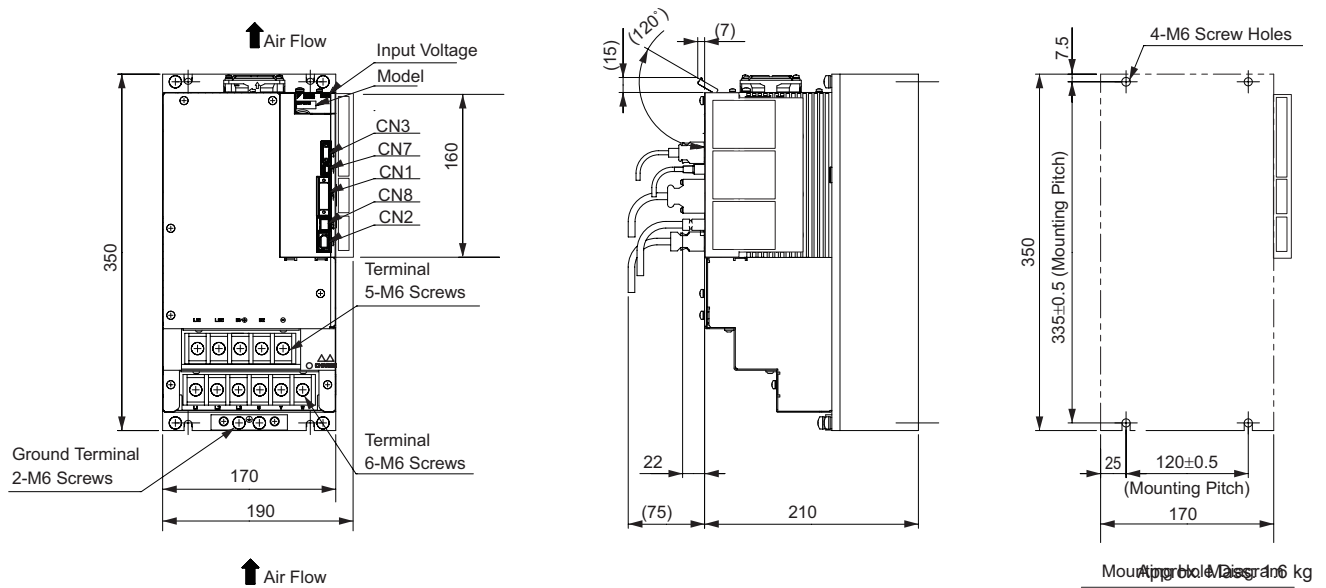

(10) Three-phase 200 VAC, Model: SGD V590AE□A002000□□□, SGD V780AE□A002000□□□

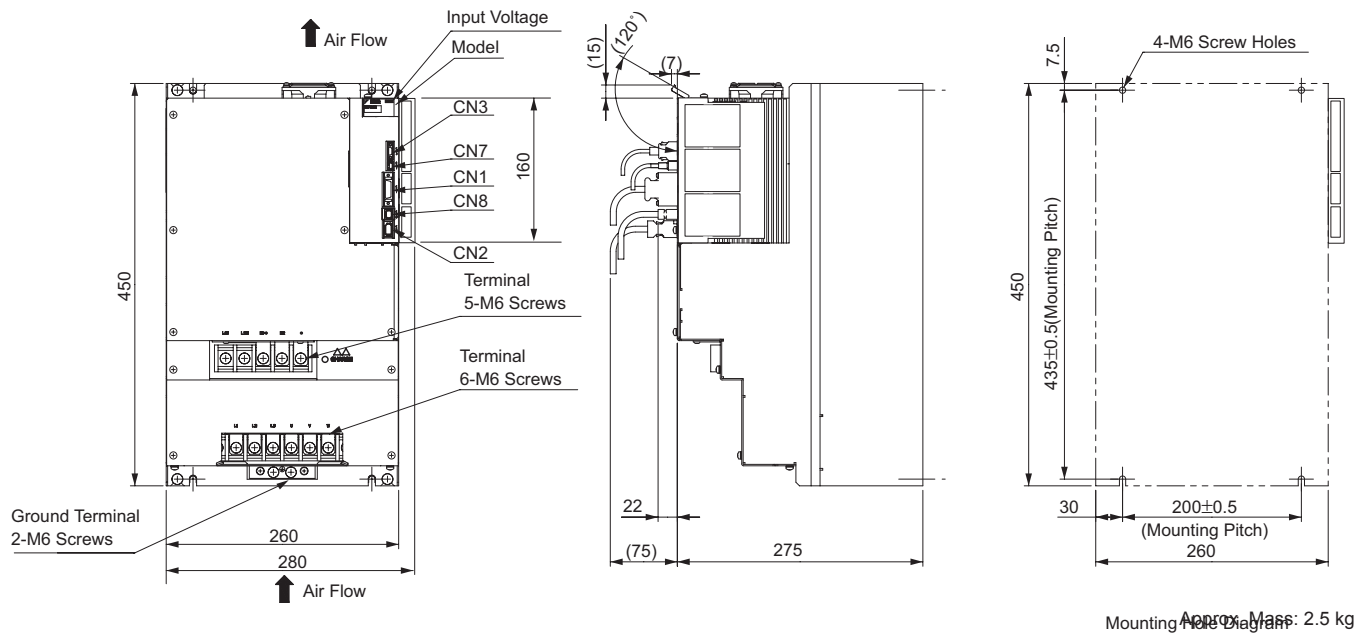

**External Dimensions** Units: mm (for Other Control Architecture Type SERVOPACKs)

(11) Three-phase 400 VAC, Model: SGDV1R9DE□A00200□□□, 3R5DE□A00200□□□, and 5R4DE□A00200□□□

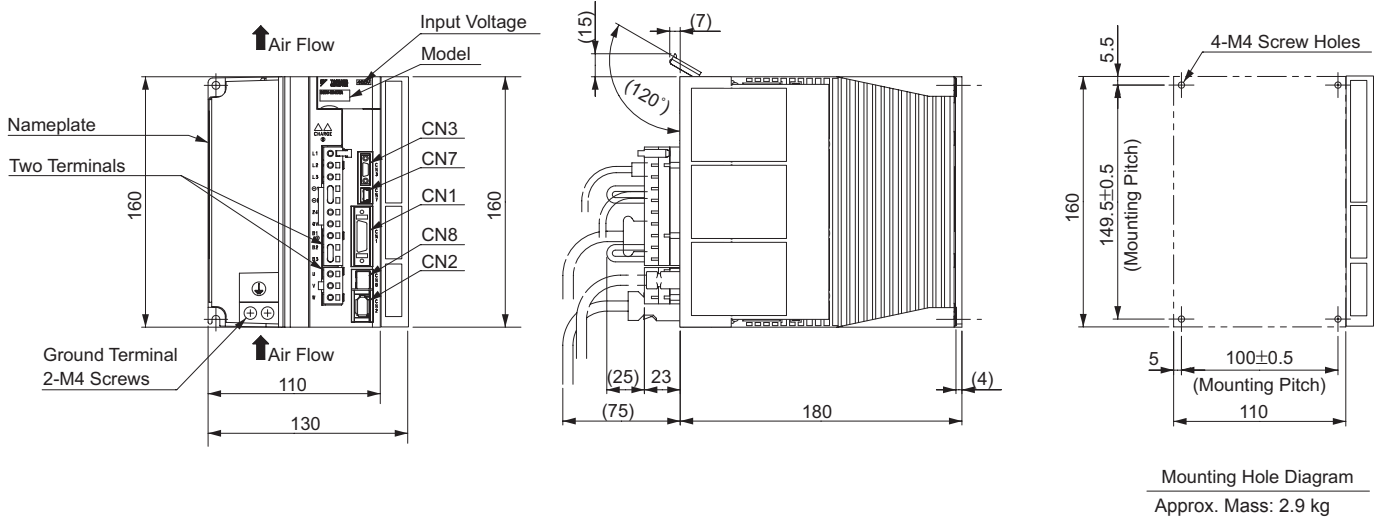

(12) Three-phase 400 VAC, Model: SGDV8R4DE□A00200□□□ and 120DE□A00200□□□,

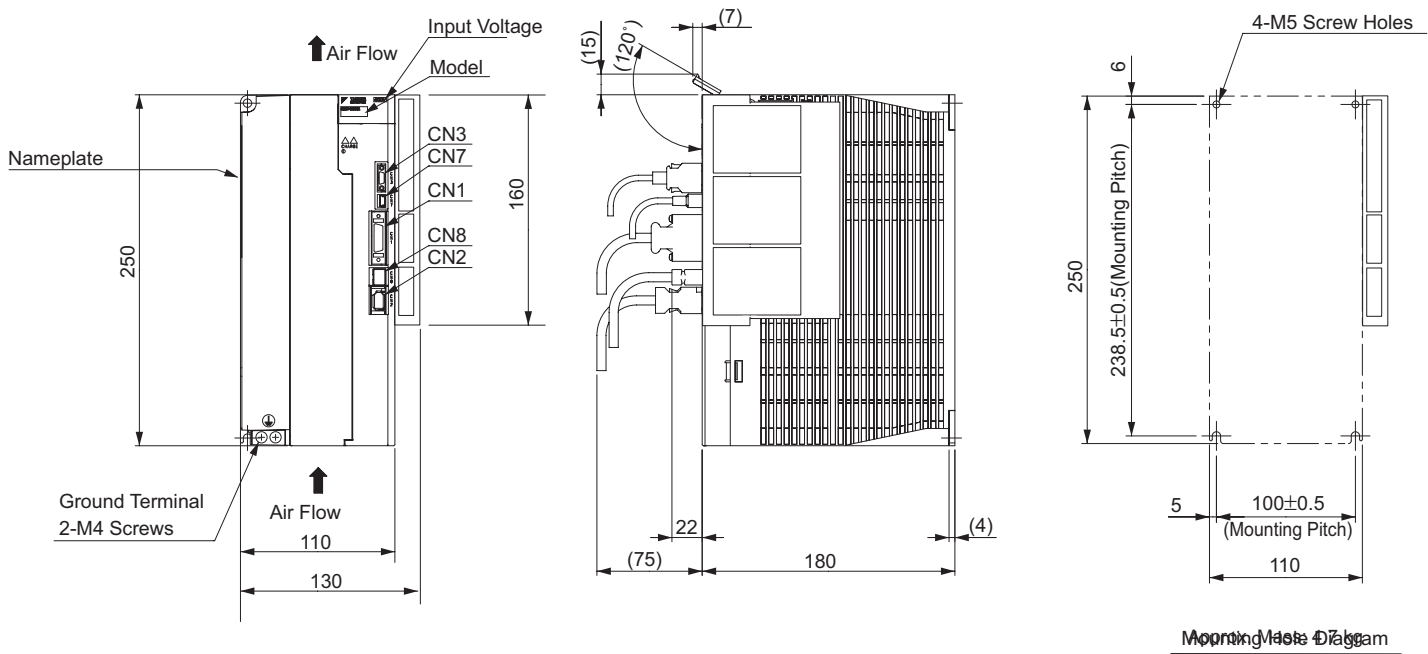

SERVOPACKs with Additional Options



External Dimensions Units: mm (for Other Control Architecture Type SERVOPACKs)

(13) Three-phase 400 VAC, Model: SGDV170DE□A002000□□□

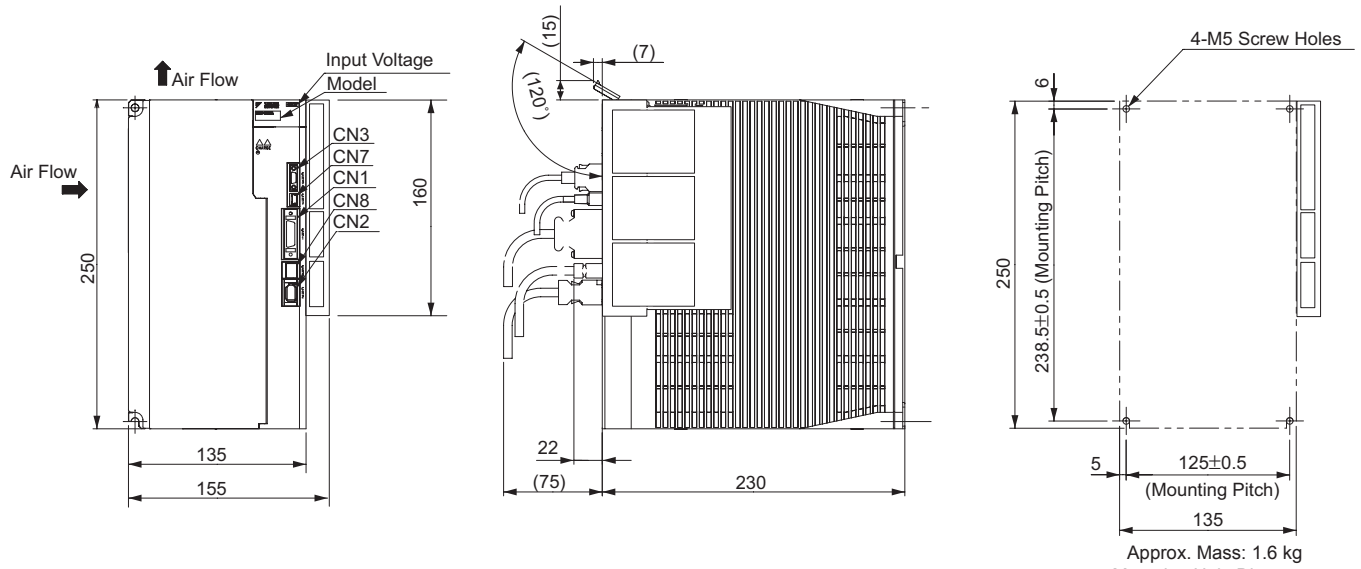

(14) Three-phase 400 VAC, Model: SGDV210DE□A002000□□□ and 260DE□A002000□□□

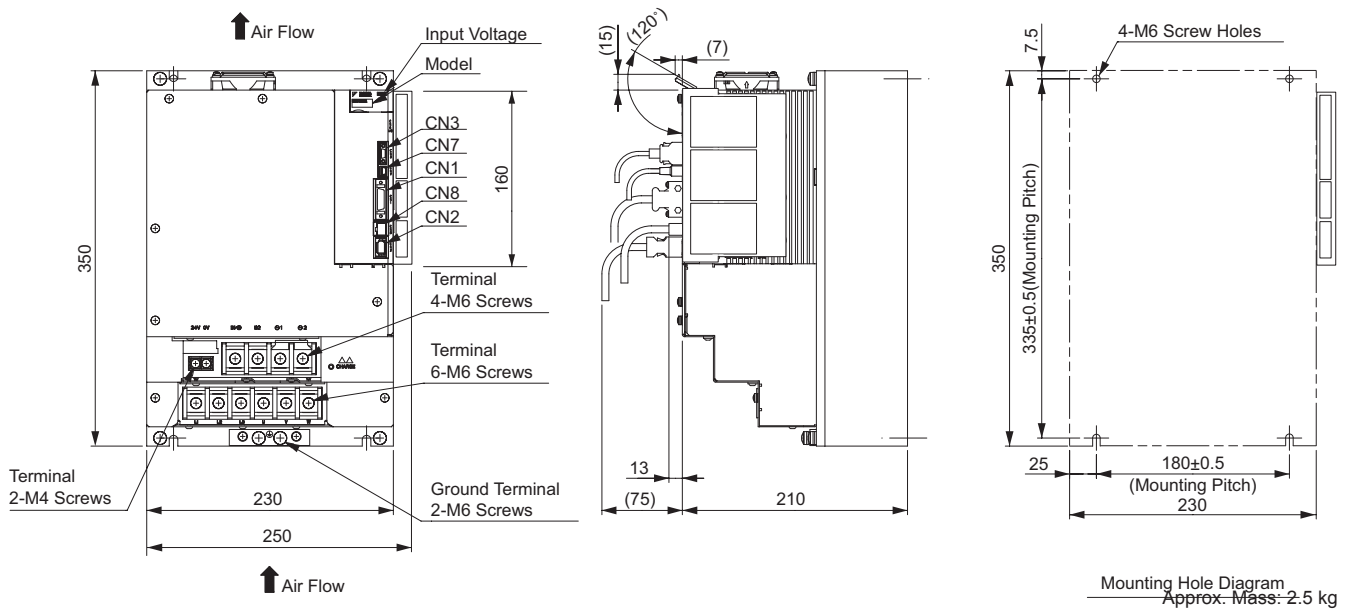

External Dimensions Units: mm (for Other Control Architecture Type SERVOPACKs)

(15) Three-phase 400 VAC, Model: SGDV280DE□A002000□□□ and 370DE□A002000□□□

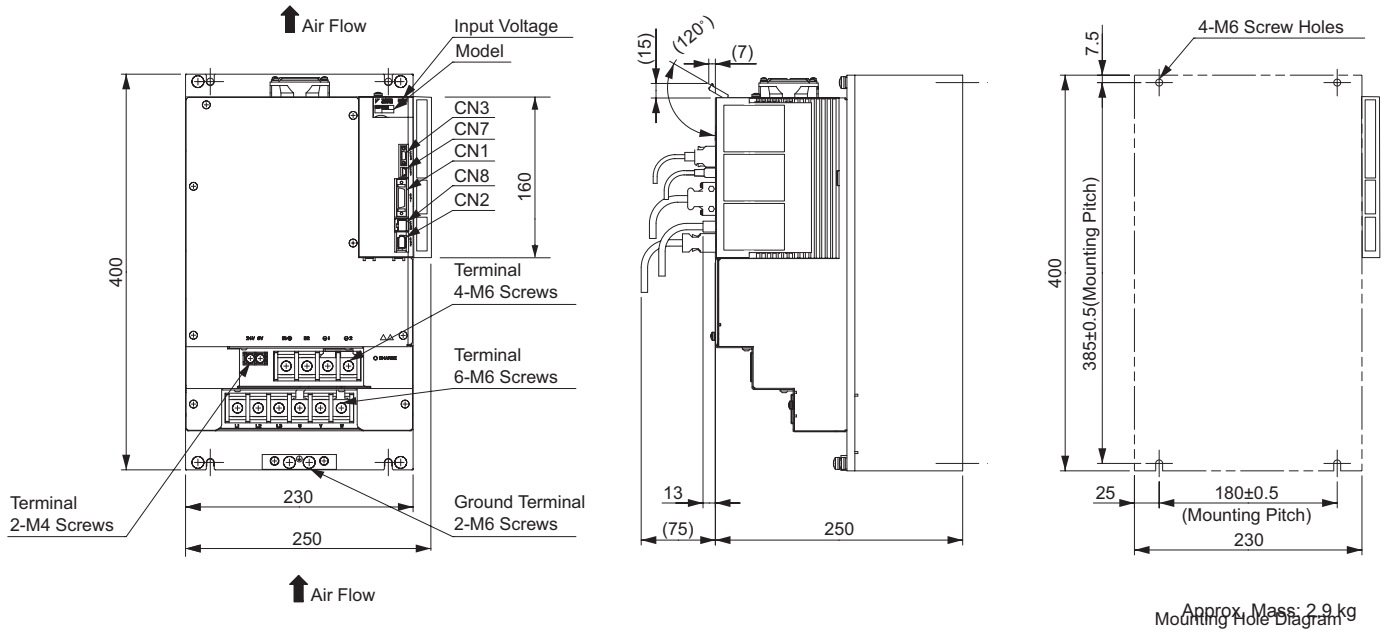

Connectors for Base-mounted SERVOPACKs





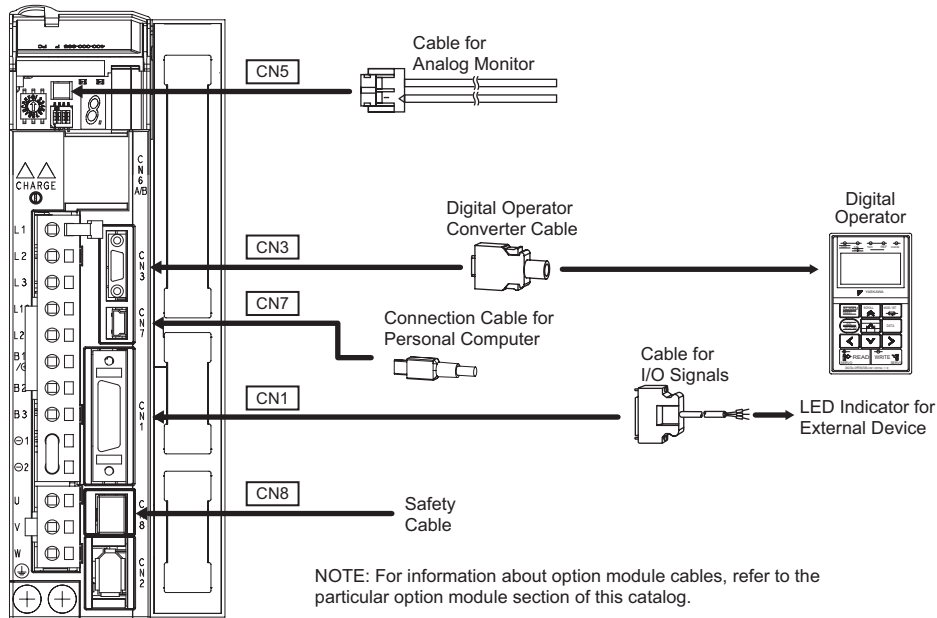

Port	Model	Pin	Manufacturer
CN1	10226-52A2PL	26	Sumitomo 3M Ltd.
CN2	53984-0671	6	Molex Japan Co., Ltd.
CN3	HDR-EC14LFDTN-SLE-PLUS	14	Honda Tsushin Kogyo Co., Ltd.
CN7	MNC23-5K5H00	5	ADVANCED-CONNECTEK INC.
CN8	1981080-1	8	Tyco Electronics AMP K.K.

Note: The connectors above or their equivalents are used for SERVOPACKs.

## Selecting Cables

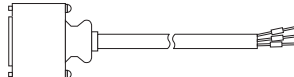
- Cables for **CN1** **CN3** **CN5** **CN7** **CN8** **CN11** for SERVOPACKs with additional options

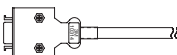

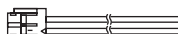
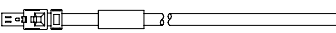
Name	Length	Order No.	Specifications	Details	
<b>CN1</b> Cables for I/O Signals	Connector Kit	JZSP-CSI9-2-E	Soldered 	(1)	
	Connector Terminal Converter Unit	0.5 m	SBK-U-VBA-A5	Terminal Block and 0.5 m Connection Cable 	(2)
		1 m	SBK-U-VBA-01		
		3 m	SBK-U-VBA-03		
	Cable with Loose wire at One End	1 m	JZSP-CSI02-1-E		(3)
		2 m	JZSP-CSI02-2-E		
3 m		JZSP-CSI02-3-E			
<b>CN3</b>	Digital Operator	JZSP-OP05A-1-E	With Connection Cable (1 m) 	(4)	
	Digital Operator Converter Cable <sup>*1</sup>	0.3 m	JZSP-CVS05-A3-E	Cable with Connectors at Both Ends 	(5)
<b>CN7</b> Connection Cables for Personal Computer	2.5 m	JZSP-CVS06-02-E	Cable with Connectors at Both Ends 	(6)	
<b>CN5</b> Cables for Analog Monitor	1 m	JZSP-CA01-E	SERVOPACK End 	(7)	
<b>CN8</b> Cables for Safety Functions	Cables with Connector <sup>*2</sup>	3 m	JZSP-CVH03-03-E		(8)
	Connector kit <sup>*3</sup>	Contact Tyco Electronics AMP K.K. Product name : Industrial Mini I/O D-shape Type1 Plug Connector Kit Model : 2013595-1			

\*1 : A converter cable is required to use  $\Sigma$ -III series digital operators (model: JZSP-OP05A) for  $\Sigma$ -V series SERVOPACKs.

\*2 : When using the safety function, connect this cable to the safety devices.

Even when not using the safety function, use SERVOPACKs with the Safe Jumper Connector (model: JZSP-CVH05-E) connected.

\*3 : Use the connector kit when you make cables yourself.

Selecting Cables

(1) Connector Kit for CN1

Use the following connector and cable to assemble the cable. The CN1 connector kit includes one case and one connector.

Connector Kit		Case		Connector	
Model	Model	Qty	Model	Model	Qty
JZSP-CSI9-2-E	10326-52A0-008*	1 set	10126-3000PE* (Soldered)		1

\* : Manufactured by Sumitomo 3M Ltd.

· Cable Size

Item	Specifications
Cable	Use twisted-pair or twisted-pair shielded wire.
Applicable Wires	AWG24, 26, 28, 30
Cable Finished Diameter	16 dia. max.

· Dimensional Drawings of Case

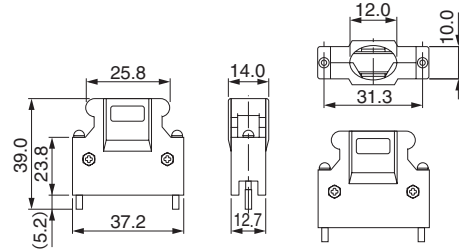

· Dimensional Drawings of Connector

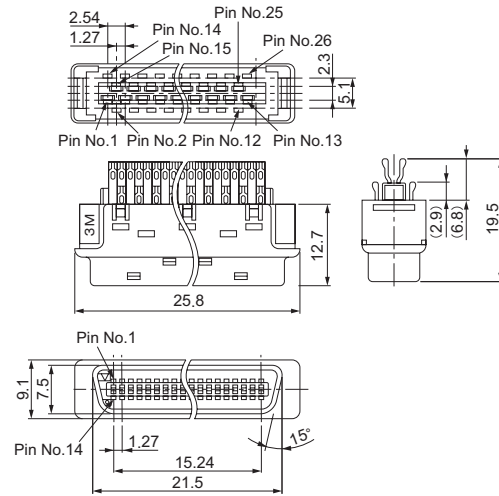

(2) Connector Terminal Converter Unit for CN1 (SBK-U-VBA-xx)

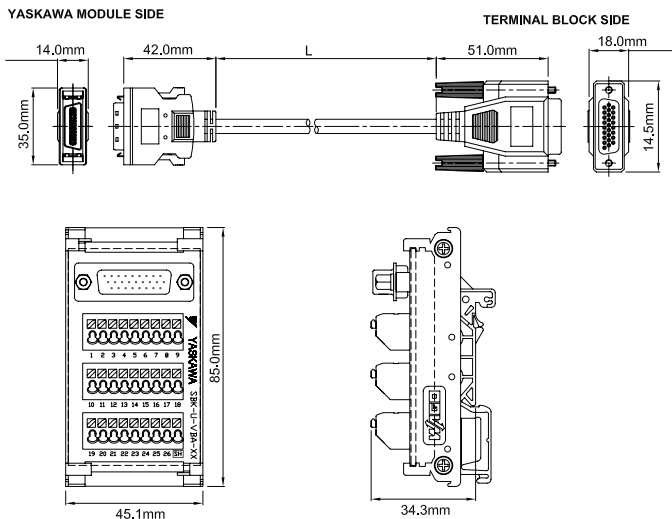

CABLE SPECIFICATION (mm)	
OUTER DIAMETER	6.5 +/- 0.2mm
BENDING RADIUS	6 x O.D. MINIMUM 15 x O.D. FOR LONG TERM RELIABILITY

ITEM#	L = LENGTH (mm)
SBK-U-VBA-A5	500 +/- 38.1
SBK-U-VBA-01	1000 +/- 38.1
SBK-U-VBA-03	3000 +/- 38.1

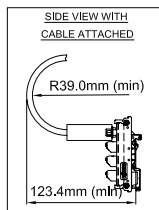

SBK-U-VBA-xx Function Chart for SGDV Servo Amplifier

Pin No.	SGDV Mechatrolink-II type / SGDV Option type	
	Signal	Function
1	/BK+ (/SO1+)	Brake interlock output (+) (General purpose output 1 (+))
2	/BK- (/SO1-)	Brake interlock output (-) (General purpose output 1 (-))
3	ALM+	Servo alarm output (+)
4	ALM-	Servo alarm output (-)
5		
6	+24VIN	Control power supply for sequence signal input
7	P-OT (/SI1)	Forward run prohibited input (General purpose input 1)
8	N-OT (/SI2)	Reverse run prohibited input (General purpose input 2)
9	/DEC (/SI3)	Zero-point return deceleration switch input (General purpose input 3)
10	/EXT1 (/SI4)	External latch signal 1 input (General purpose input 4)
11	/EXT2 (/SI5)	External latch signal 2 input (General purpose input 5)
12	/EXT3 (/SI6)	External latch signal 3 input (General purpose input 6)
13	/SI0	General purpose input 0
14	BAT (+)	Battery (+) input
15	BAT (-)	Battery (-) input
16	SG	Signal ground
17	PAO	Phase-A pulse output (+)
18	/PAO	Phase-A pulse output (-)
19	PBO	Phase-B pulse output (+)
20	/PBO	Phase-B pulse output (-)
21	PCO	Phase-C pulse output (+)
22	/PCO	Phase-C pulse output (-)
23	/SO2+	General purpose output 2 (+)
24	/SO2-	General purpose output 2 (-)
25	/SO3+	General purpose output 3 (+)
26	/SO3-	General purpose output 3 (-)

Note: General purpose input and output signals are shown with their default signals assigned - signal assignment may have been changed by parameter

## Selecting Cables

### Selecting Cables Units: mm

#### (3) Cable with Loose Wires at One End for CN1 Dimensional Drawings of Cable

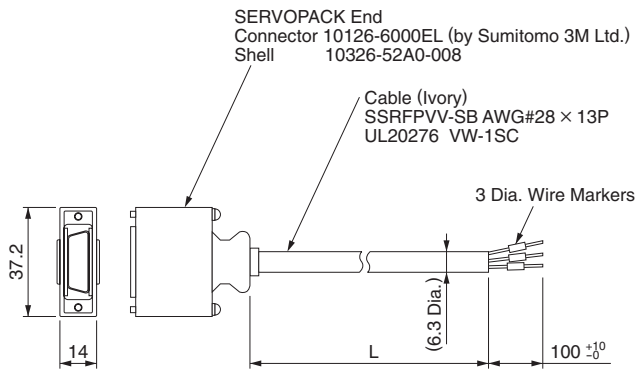

Model	Cable Length
JZSP-CSI02-1-E	1 m
JZSP-CSI02-2-E	2 m
JZSP-CSI02-3-E	3 m

#### ● Cable with Loose Wires at One End for CN1 Connection Diagram of JZSP-CSI02-□-E Cable

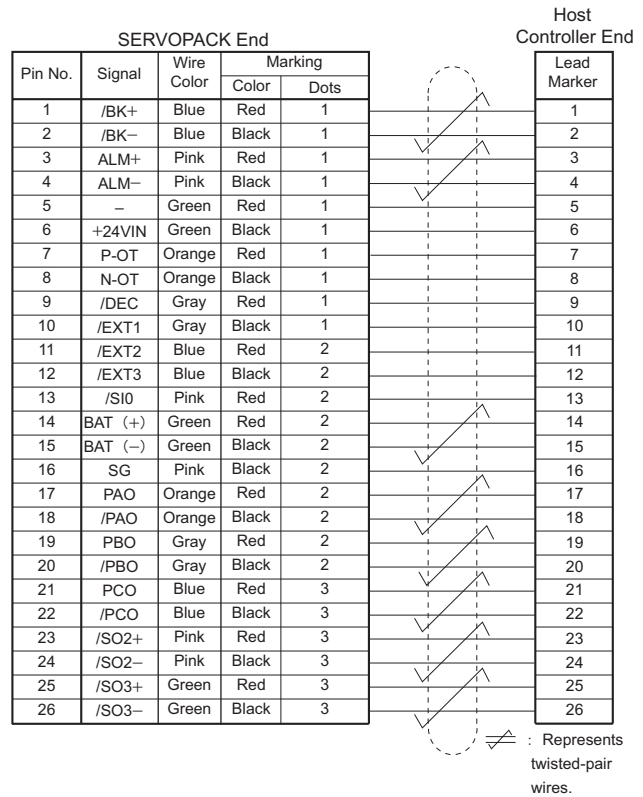

#### (4) Digital Operator (Model: JUSP-OP05A-1-E)

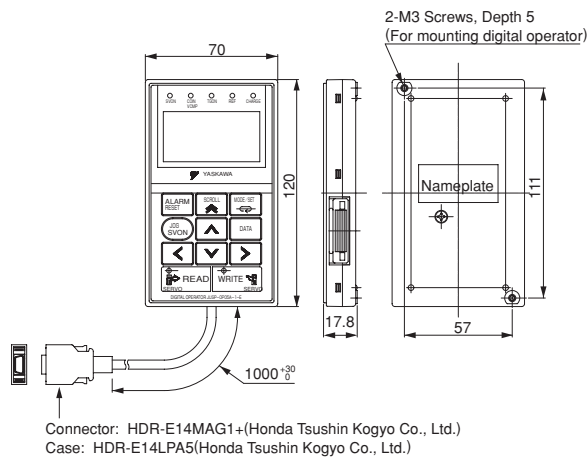

#### (5) Digital Operator Converter Cable for CN3

(Model: JZSP-CVS05-A3-E)

A converter cable is required to use  $\Sigma$ -III series digital operators (model: JUSP-OP05A) for  $\Sigma$ -V series SERVOPACKS.

· Dimensional Drawings

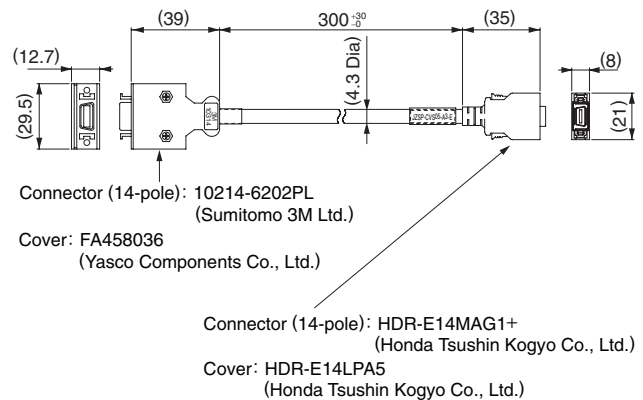

## Selecting Cables

### (6) Connection Cable for Personal Computer for CN7 (Model: JZSP-CVS06-02-E)

#### · Dimensional Drawings

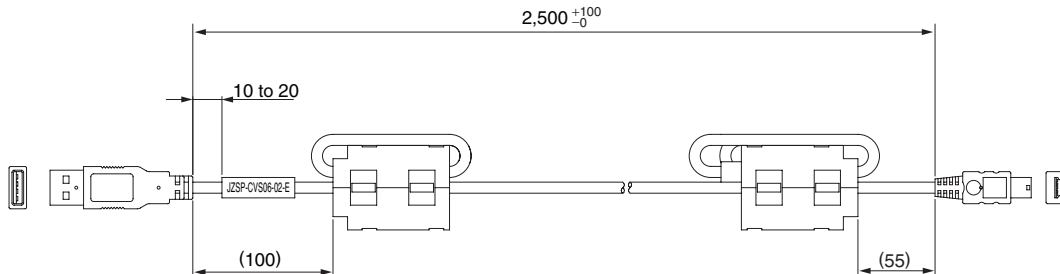

#### IMPORTANT

Use a cable specified by Yaskawa.  
When using other cables, operation cannot be guaranteed.

### (7) Cable for Analog Monitor for CN5 (Model: JZSP-CA01-E)

#### · Dimensional Drawings

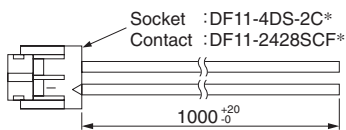

\* : Manufactured by Hirose Electric Corporation.

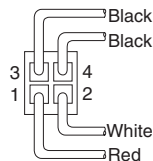

View from Cable End

#### · Specifications

Pin No.	Cable Color	Signal	Standard Settings
1	Red	Analog Monitor 2	Motor speed : 1V/1000 min <sup>-1</sup>
2	White	Analog Monitor 1	Torque reference : 1V/100% rated torque
3, 4	Black (2 cables)	GND(0V)	-

Note : The specifications above are factory settings. Monitor specifications can be changed by changing parameters Pn006 and Pn007.

### (8) Cable with Connector for CN8 (Model: JZSP-CVH03-03-E)

#### · Dimensional Drawings

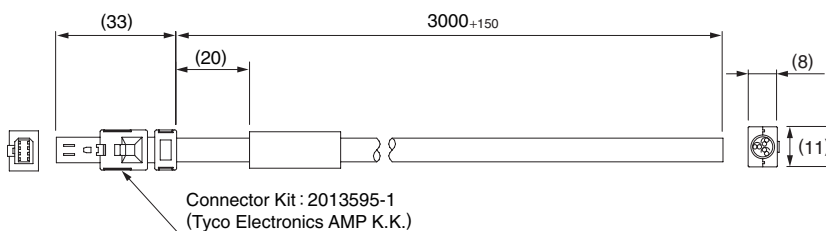

#### · Specifications

Pin No.	Signal	Lead Color	Marking Color
1	Not used	-	-
2	Not used	-	-
3	/HWBB1-	White	Black
4	/HWBB1+	White	Red
5	/HWBB2-	Gray	Black
6	/HWBB2+	Gray	Red
7	EDM1-	Orange	Black
8	EDM1+	Orange	Red



# Fully-Closed Loop Control Option

## ● System Configuration for Fully-Closed Loop Control

When using rotary servomotors with Fully-Closed loop control, use SERVOPACKs with option module for Fully-Closed loop control.

SERVOPACK with Fully-Closed Loop Control Option

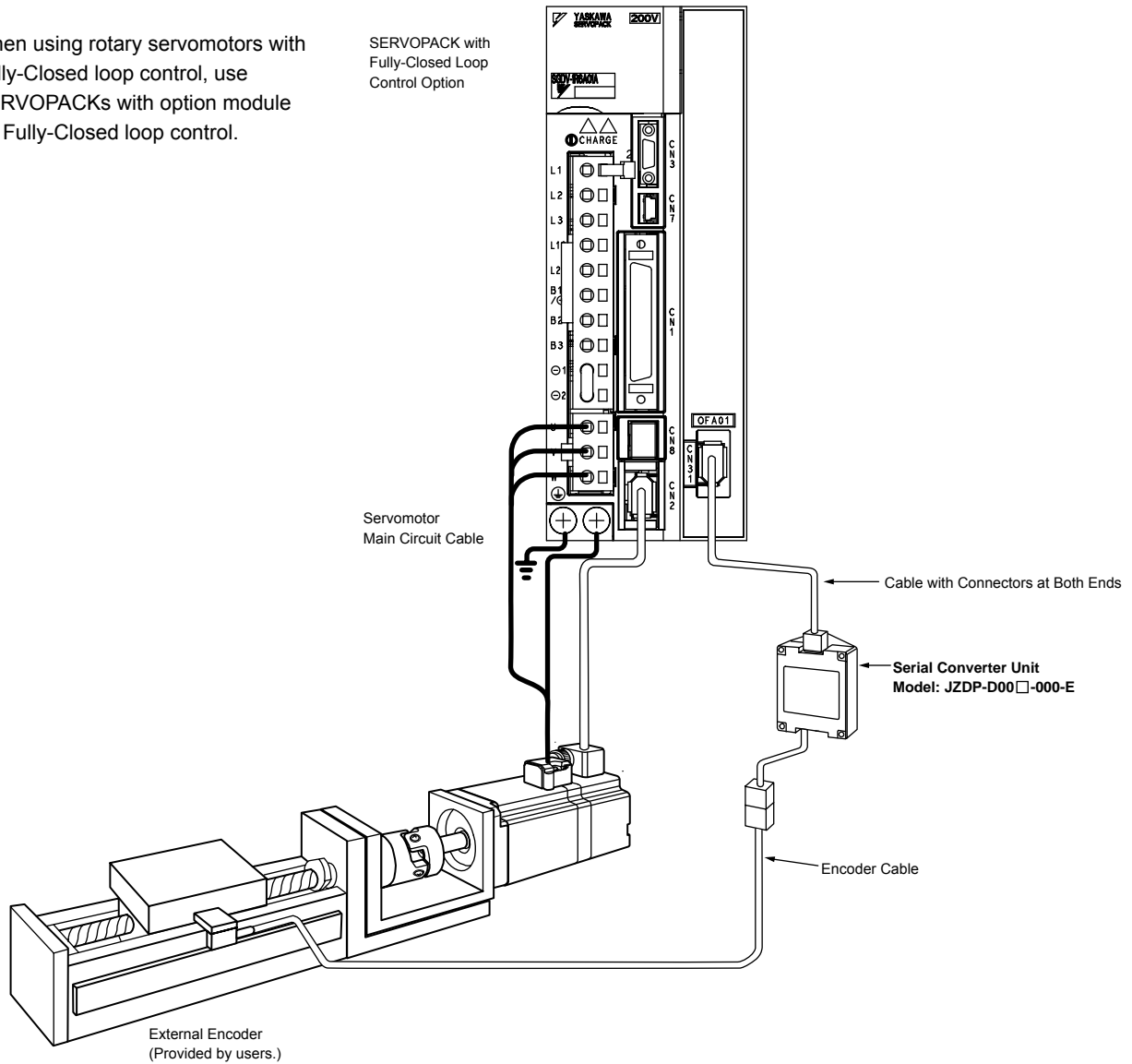

## ● Model Designations

JZDP - D00□ - 000 - E

Serial Converter Unit Model

Code	Appearance	Applicable External Encoder	Hall Sensor
D003		Manufactured by HEIDENHAIN Corporation	None
D005		Manufactured by Renishaw plc.	None

Heidenhain serial converters are non-stock.

Note: Using the serial converter unit JZDP-A□□□ with SGD V SERVOPACK will void our guarantee.

Option Module for Fully-Closed Loop Control

● External Dimensions Units: mm

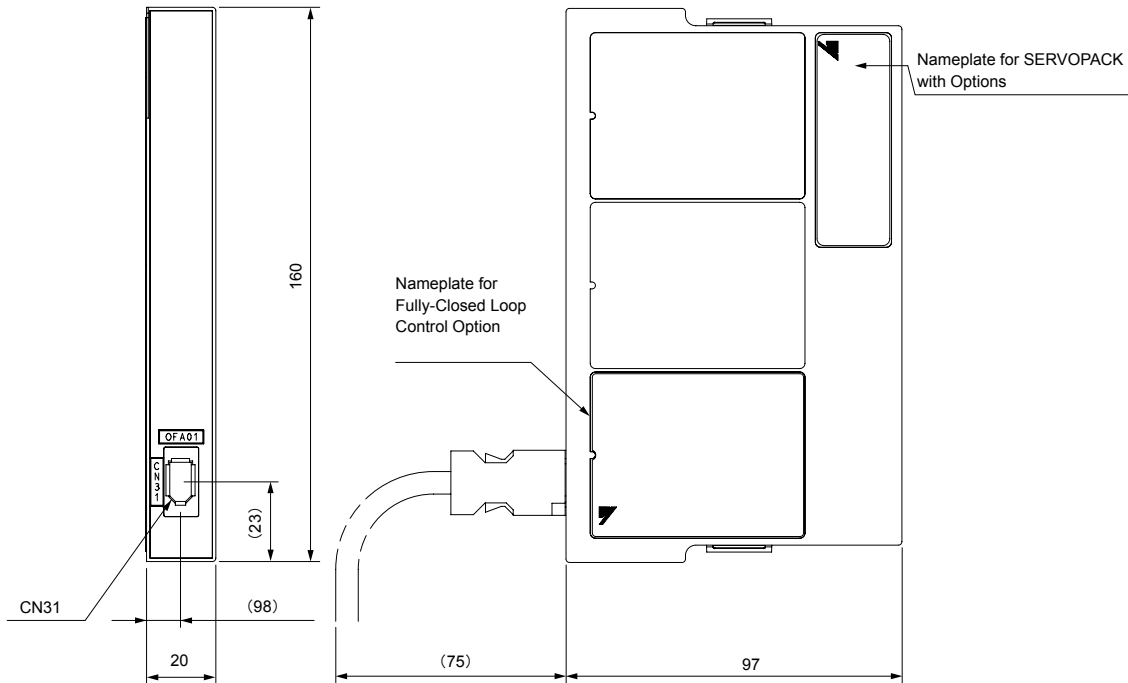

Approx. Mass: 0.1 kg

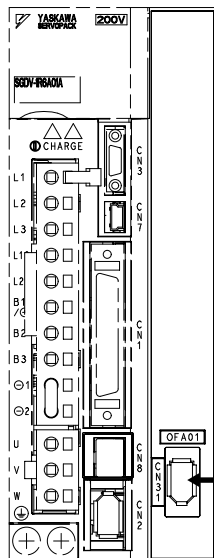

Connector

Port	Model	Pin	Manufacturer
CN31	53984-0671	6	Molex Japan Co., Ltd.

Note: The connectors above or their equivalents are used for SERVOPACKs.

Connection Cable Between Fully Closed Loop Connector and Serial Converter Unit (see page 314).

Front View (mounted on analog and pulse train type SERVOPACK)



# Serial Converter Units

## ● Characteristics and Specifications

Items	Specifications	
Electrical Characteristics	Power Supply Voltage	+5.0 V $\pm$ 5%, ripple content 5% max.
	Current Consumption <sup>*1</sup>	120 mA typ. 350 mA max.
	Signal Resolution	Input two-phase sine wave: 1/256 pitch
	Max. Response Frequency	250 kHz
	Analog Input Signals <sup>*2</sup> (cos, sin, Ref)	Differential input amplitude: 0.4 to 1.2 V Input signal level: 1.5 to 3.5 V
	Output Signal <sup>*3</sup>	Position data, alarms
	Output Method	Serial data communications [HDLC (High-level Data Link Control) protocol format with Manchester codes]
	Output Circuit	Balanced type transceiver (SN75LBC176 or the equivalent), internal terminating resistor: 120 $\Omega$
Mechanical Characteristics	Approx. Mass	150 g
	Vibration Resistance	98 m/s <sup>2</sup> max. (10 to 2500 Hz) in three directions
	Impact Resistance	980 m/s <sup>2</sup> , (11 ms) two times in three directions
Environmental Conditions	Surrounding Air Temperature	0 to 55°C
	Storage Temperature	-20 to 80°C
	Humidity	20% to 90%RH (no condensation)

\*1: The current consumption of the external encoder is not included in this value.

The current consumption of the external encoder must be taken into consideration for the current capacity of host controller that supplies the power.

\*2: Input a value within the specified range. Otherwise, incorrect position information is output, and the device may be damaged.

\*3: The transmission is enabled 100 to 300 ms after the power turns on.

## ● Analog Signal Input Timing

The following figure shows the input timing of the analog signals.

When the cos and sin signals are shifted 180 degrees, the differential signals are the /cos and /sin signals.

The specifications of the cos, /cos, sin, and /sin signals are identical except for the phase.

Input the signals Ref and /Ref so that they shall cross each other as shown in the figure because they are input into the converter. When they are crossed, the output data will be counted up.

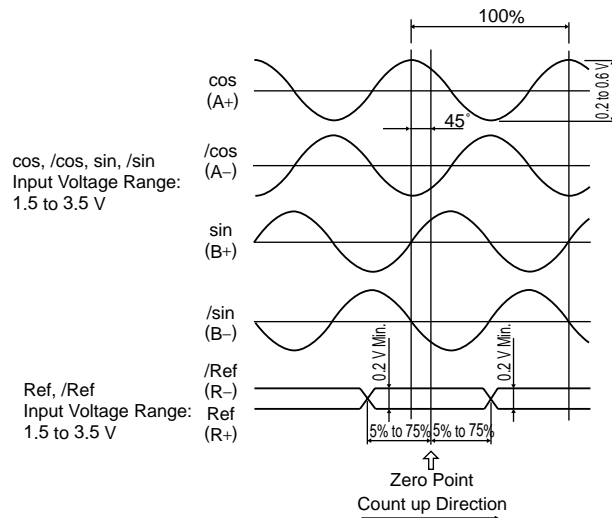

### IMPORTANT

#### ■ Precautions

- 1 Never perform insulation resistance and withstand voltage tests.
- 2 When analog signals are input to the serial converter unit, noise influence on the analog signals affects the unit's ability to output correct position information. The analog cable must be as short as possible and shielded.
- 3 Do not connect or disconnect the unit while power is being supplied, or the unit may be damaged.
- 4 When using multiple axes, use a shield cable for each axis. Do not use a shield cable for multiple axes.

**Serial Converter Units** Units: mm

● External Dimensions

(1) Model: JZDP-D003-□□□-E

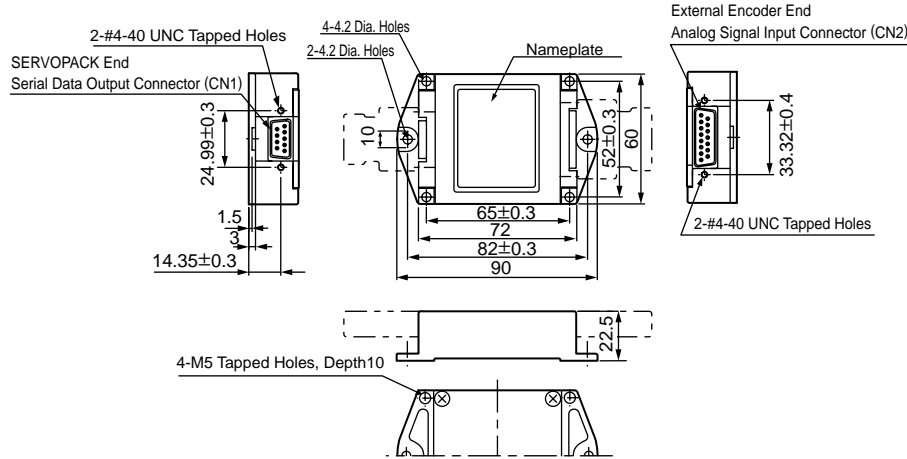

(2) Model: JZDP-D005-□□□-E

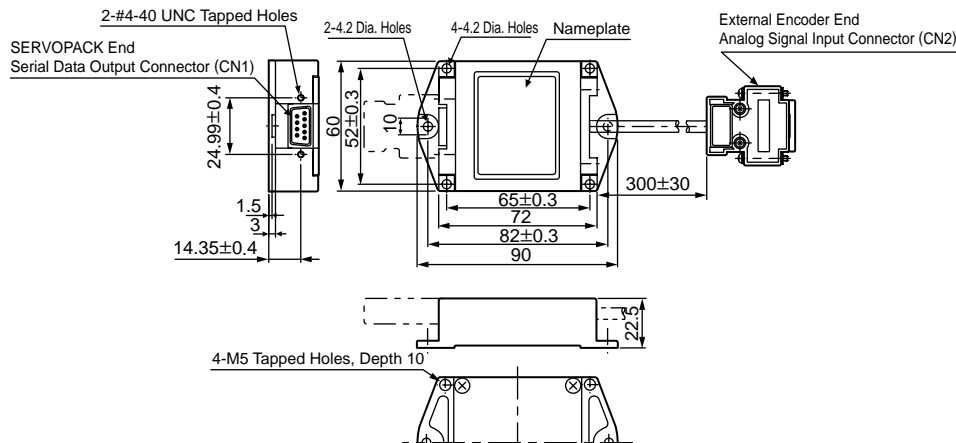

● Connection Cables

● Recommended Cables

Name	Application	Model	Length
Cables with Connectors at Both Ends	Connection between SERVOPACK (Option module for Fully-Closed loop control ) connector CN31 and serial converter unit	JZSP-CLP70-03-E	3 m
		JZSP-CLP70-05-E	5 m
		JZSP-CLP70-10-E	10 m
		JZSP-CLP70-15-E	15 m
		JZSP-CLP70-20-E	20 m

● Dimensional Drawing

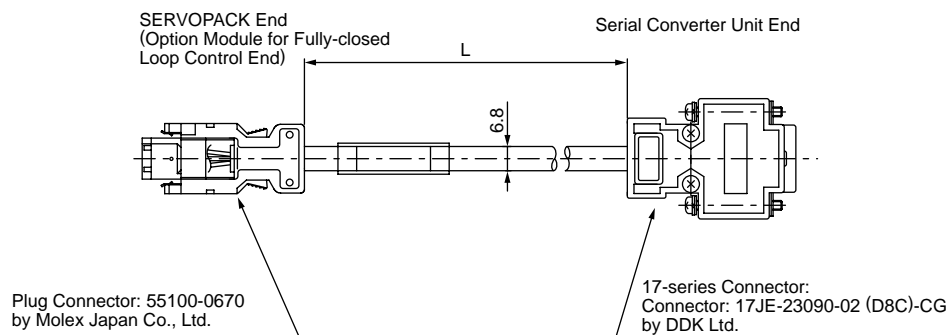

# Serial Converter Units

## ● Connection Examples

### (1) Connection Example with External Encoder by HEIDENHAIN Corporation

Model: JZDP-D003-□□□-E

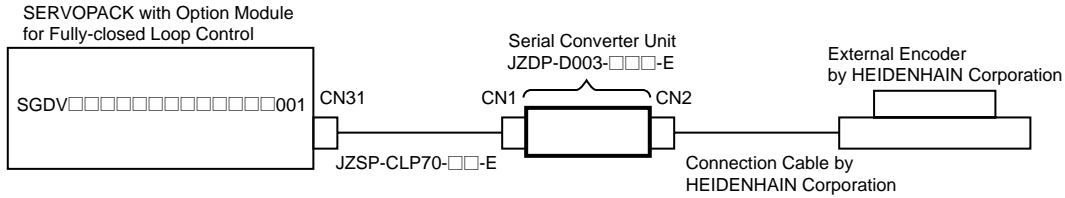

Pin No.	Signal
1	+5V
2	Phase S output
3	Not used
4	Not used
5	0V
6	Phase /S output
7	Not used
8	Not used
9	Not used
Case	Shield

**CN1**  
SERVOPACK End  
Serial Data Output

17-series Connector:  
17LE-13090-27-FA  
(Socket) by DDK Ltd.

Pin No.	Signal
1	cos input (A+)
2	0V
3	sin input (B+)
4	+5V
5	Not used
6	Not used
7	/Ref input (R-)
8	Not used
9	/cos input (A-)
10	0V sensor
11	/sin input (B-)
12	5V sensor
13	Not used
14	Ref input (R+)
15	Not used
Case	Shield

**CN2**  
External Encoder End  
Analog Signal Input

17-series Connector:  
17LE-13150-27-FA  
(Socket) by DDK Ltd.

Notes: 1 Do not use the unused pins.  
2 The external encoder (analog 1 Vp-p output, D-sub 15-pin) by HEIDENHAIN Corporation can be directly connected.

### (2) Connection Example with External Encoder by Renishaw plc.

Model : JZDP-D005-□□□-E

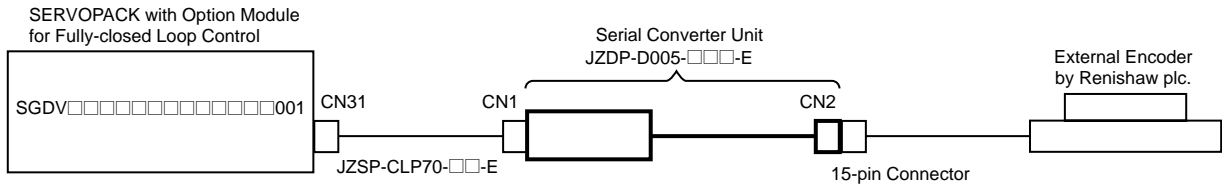

Pin No.	Signal
1	+5V
2	Phase S output
3	Not used
4	Not used
5	0V
6	Phase /S output
7	Not used
8	Not used
9	Not used
Case	Shield

**CN1**  
SERVOPACK End  
Serial Data Output

17-series Connector:  
17LE-13090-27-FA  
(Socket) by DDK Ltd.

Pin No.	Signal
1	/cos input (V1-)
2	/sin input (V2-)
3	Ref input (V0+)
4	+5V
5	5Vs
6	Not used
7	Not used
8	Not used
9	cos input (V1+)
10	sin input (V2+)
11	/Ref input (V0-)
12	0V
13	0Vs
14	Not used
15	Inner (0V)
Case	Shield

**CN2**  
External Encoder End  
Analog Signal Input

17-series Connector:  
17JE-13150-02 (D8C) A-CG  
(Socket) by DDK Ltd.

SERVOPACK does not have the function to process Vq signals.

Notes: 1 Do not use the unused pins.  
2 The external encoder (analog 1 Vp-p output, D-sub 15-pin) by Renishaw plc. can be directly connected. However, the BID and DIR signals are not connected.  
3 Use the external encoder-end connector to change the home position specifications of the external encoder.

Serial Converter Units

(3) Connection Example with External Encoder by Mitutoyo Corporation (Model: ABS ST78□A)  
When using these external encoders, serial converter units are not required.

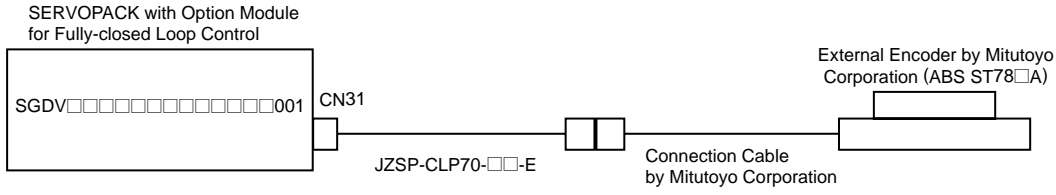

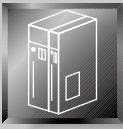

# EtherCAT(CoE) Communication Reference Option

## ● System Configuration for EtherCAT (CoE) Communication Reference

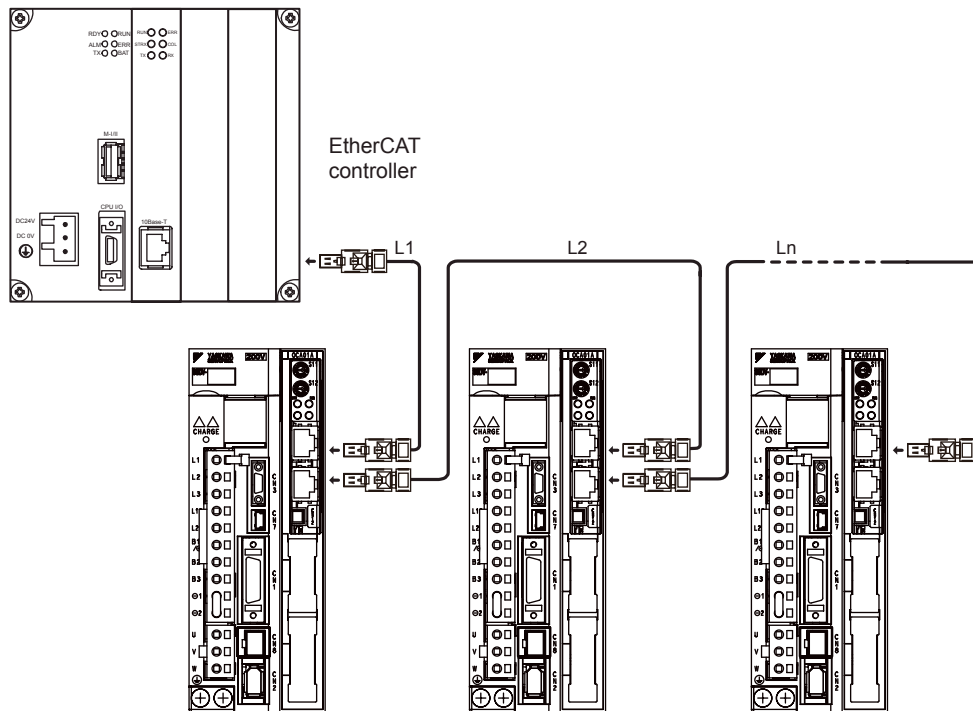

### EtherCAT Connector (RJ45)

Connector	Description
CN11A	EtherCAT signal input
CN11B	EtherCAT signal output

#### • Connector Pin Arrangement

Pin No.	Signal Name	Remarks
1	TD+	Send data
2	TD-	
3	RD+	Receive data
4	—	N.C.*
5	—	N.C.*
6	RD-	Receive data
7	—	N.C.*
8	—	N.C.*

\* Pins denoted as N.C. do not connect to any signal.

**EtherCAT (CoE) Communication Reference Option**

● External Dimensions Units: mm

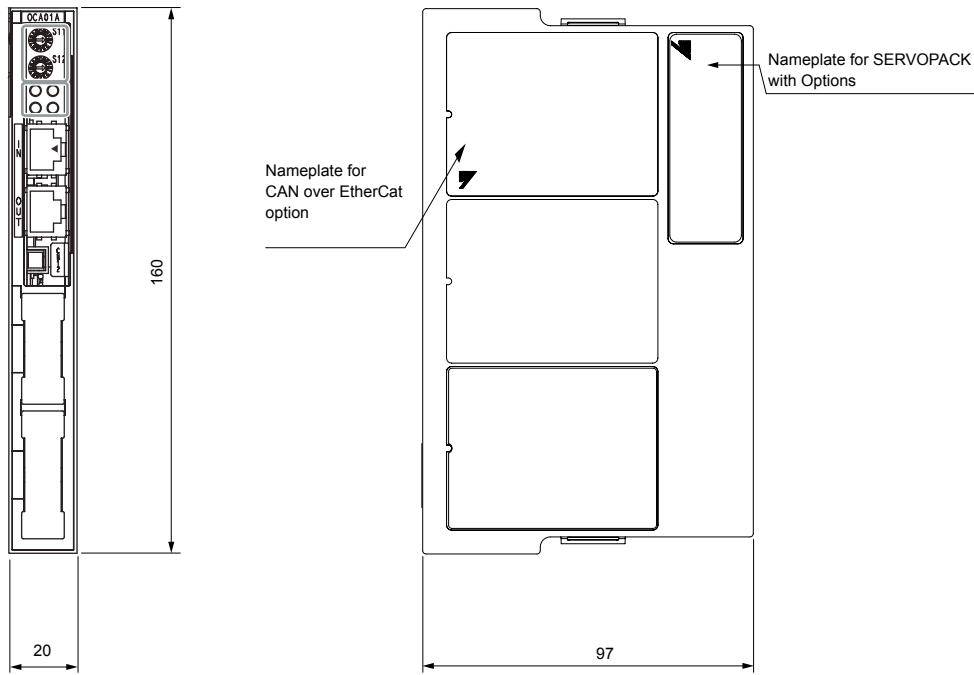

Approx. Mass: 0.1 kg

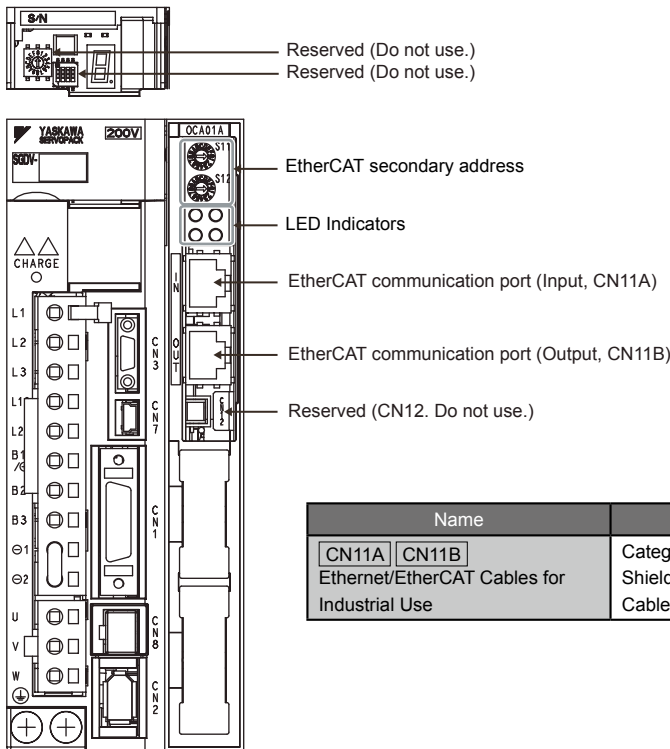

Front View: With front cover open

Name	Specifications
CN11A   CN11B Ethernet/EtherCAT Cables for Industrial Use	Category: CAT5e Shield specifications: S/UTP or S/STP Cable length: 50 m maximum

## Specifications of the EtherCAT(CoE) Communication Reference Option

### ● Specifications

Items		Specifications
Power Specification	Power Supply Method	Supplied from the control power supply of the servo amplifier
Operating Conditions	Surrounding Air/Storage Temperature	Surrounding air temperature: 0 to 55°C, Storage temperature: -20 to 85°C
	Ambient/Storage Humidity	90% RH or less (with no condensation)
	Vibration/Shock Resistance	Vibration resistance: 4.9 m/s <sup>2</sup> , Shock resistance: 19.6 m/s <sup>2</sup>
	Protection Class/ Pollution Degree	Protection class: IP10, pollution degree: 2 Do not use SERVOPACKs in the following locations: <ul style="list-style-type: none"> <li>• Locations subject to corrosive or flammable gases</li> <li>• Locations subject to exposure to water, oil, or chemicals</li> <li>• Locations subject to dust, including iron dust, and salts</li> </ul>
	Altitude	1000 m or less
	Others	Do not use SERVOPACKs in the following locations: <ul style="list-style-type: none"> <li>• Locations subject to static electricity noise, strong electromagnetic/magnetic fields, radioactivity</li> </ul>
Conformance Standards		UL508C EN50178, EN55011/A2 Group1 Class A, EN61000-6-2 EN61800-3, EN61800-5-1, EN954-1, IEC61508-1 ~ 4
RoHS Directive		Compliant
Baud Rate		100Mbps
Max. No. of Stations		65536 stations
Transmission Cycle		125 μs or more
Cable Length between Nodes		50 m max
Topology		Cascade, star, ring, line
Connector		RJ-45
Profile		CANopen(CoE) IEC61800-7 CiA402 Drive Profile
Control Mode		<ul style="list-style-type: none"> <li>• Homing mode</li> <li>• Profile position mode</li> <li>• Interpolated position mode</li> <li>• Profile velocity mode</li> <li>• Profile Torque mode</li> <li>• Cyclic sync position mode</li> <li>• Cyclic sync velocity mode</li> <li>• Cyclic sync torque mode</li> </ul>
SERVOPACK Performance and Functions		Response frequency: 1.6 kHz Various adjustment functions are available.
Display		EtherCAT RUN indicator (RUN) × 1 EtherCAT ERR indicator (ERR) × 1 EtherCAT Link/Activity indicator × 2
Rotary Switch		Secondary Address : × 2







# MP2600iec Single-Axis Motion Controller Option

The MP2600iec Single Axis Motion Controller Option for the Sigma-5 amplifier provides a compact, all-in-one, servo/controller package with the following features:

- IEC61131-3 standardized programming environment with PLCopen function blocks for motion control.
- Self-tuning, anti-vibration, and other high performance, easy-to-implement servo control features
- Ethernet/IP, Modbus TCP/IP, and OPC Server, which provide connectivity to PLCs, HMIs, SCADA, MES, and ERP
- Scalability with the multi-axis MP2000iec controller platform via the common programming environment, MotionWorks IEC
- Web server that allows for maintenance diagnostics and troubleshooting
- I/O features:
  - 15 digital inputs
  - 11 digital outputs
  - 1 analog input
  - 1 analog output
  - 1 external encoder input
  - 1 external encoder latch

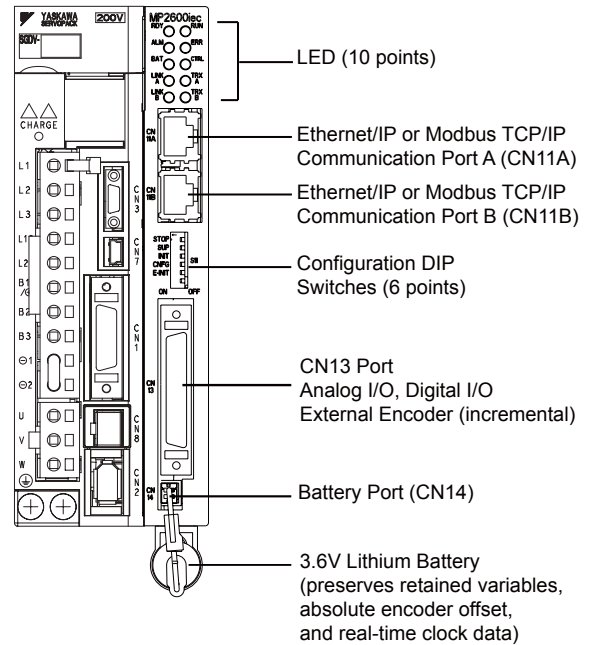

## ● External Dimensions Units: mm

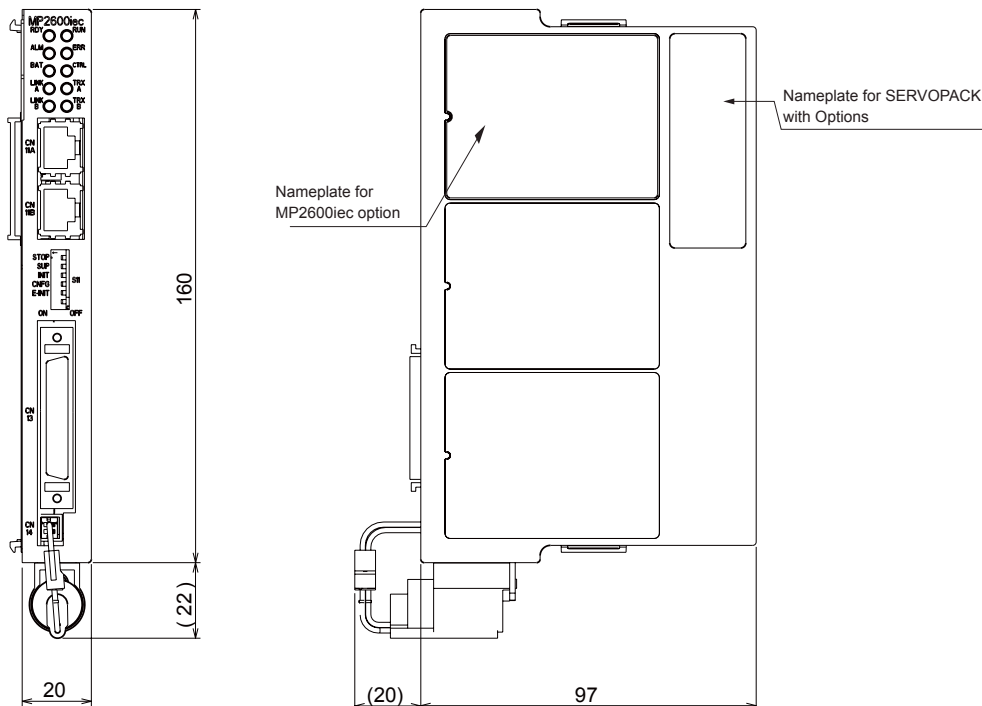

Dimensions in mm.

## Specifications of the MP2600iec Single Axis Machine Controller Option

### ● General Specifications

Items		Specifications
Environmental Conditions	Ambient Operating Temperature	0 to 55°C
	Ambient Storage Temperature	-20°C to +85°C
	Ambient Operating Humidity	90% RH or less (with no condensation)
	Ambient Storage Humidity	90% RH or less (with no condensation)
	Protection Class/Pollution Degree	Protection class: IP10, Pollution degree: 2 An environment that satisfies the following conditions. <ul style="list-style-type: none"> <li>• Free of corrosive or explosive gases</li> <li>• Free of exposure to water, oil or chemicals</li> <li>• Free of dust, salts or iron dust</li> </ul>
	Operating Altitude	1,000 m above sea level or lower
Mechanical Operating Conditions	Vibration Resistance	4.9 m/s <sup>2</sup>
	Shock Resistance	19.6 m/s <sup>2</sup>
	Others	Free of static electricity, strong electromagnetic fields, magnetic fields or exposure to radioactivity



### ● Hardware Specifications

Items		Specifications		
CPU		200 MHz, 32 bit, ARM 9		
Memory	SDRAM	32 MB		
	SRAM	512 kB with battery backup		
	Flash	4 MB flash. Code and parameter storage		
Operator interface		LED	10 LEDs (red and green - operating mode, communication and error status)	
		User Configuration	6x DIP switch (operating mode and communication configuration)	
User I/O	Controller Side (CN13)	Network	2x 100baseTX Ethernet	
		Digital input	8 programmable inputs	
		Digital output	8 programmable outputs	
		Analog input	1 ch., +/- 10V, 16 bit	
		Analog output	1 ch., +/- 10V, 16 bit	
		Pulse Counter	RS-422-compatible pulse counter input (quadrature, pulse and direction, and up/down counter modes) with 5, 12, and 24V position latch inputs	
	Servo Side (CN1)	Sequence Input	Allocated	Number of Inputs: 7 Functions: The signal allocation and positive/negative logic can be modified. Forward run prohibited (/P-OT), reverse run prohibited (/N-OT), forward torque limit (/P-CL), reverse torque limit (/N-CL), general-purpose input signal (/SI0 to /SI6)
			Fixed	Servo Alarm (ALM)
		Sequence Output	Allocated	Number of Outputs: 3 Functions: The signal allocation and positive/negative logic can be modified. Positioning completion (/COIN), speed coincidence detection(/V-CMP), servomotor rotation detection (/TGON), servo ready (/S-RDY), torque limit detection (/CLT), speed limit detection (VLT), brake (/BK), warning (/WARN), near (/NEAR)
			Fixed	
Network capability		OPC (Client and Server required) Ethernet/IP Modbus/TCP		
Programming standards		IEC61131/PLCopen		
Diagnostic and configuration interface		Web interface		
Motion control performance		1 controlled axis and one external position input at a trajectory update rate of 1 kHz		
Servo-Side Safety Functions	Input	/HWBB1, /HWBB2: Baseblock signal for power module		
	Output	EDM1: Status monitor (fixed output) of built-in safety circuit		

\* Allocated I/O can also be used as programmable I/O.

# Selecting Cables

## ● Cable Selection

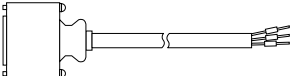
Name	Length	Order No.	Specifications	Details	
<b>CN13</b> Cables for I/O Signals	Connector Kit		JZSP-CSI9-1-E	Soldered 	(1)
	Connector Terminal Converter Unit	0.5 m	CBK-U-MP2B-A5	Terminal Block and 0.5 m Connection Cable 	(2)
		1 m	CBK-U-MP2B-01		
		3 m	CBK-U-MP2B-03		
	Flying Lead Cable	0.5 m	CFC-U-MP2B-A5		(3)
		1 m	CFC-U-MP2B-01		
3 m		CFC-U-MP2B-03			
CN14 Battery Kit		SGDV-OZC02A	3.6V Lithium Battery, cable with connector, and mounting bracket for MP2600*		
<b>CN11A</b> <b>CN11B</b> Ethernet/EtherCAT Cables for Industrial Use		Category: CAT5e Shield specifications: S/UTP or S/STP Cable length: 50 m maximum			

\* : This battery kit ships with the Sigma-5 amplifier when ordered with the MP2600 option.

### (1) Connector Kit for CN13

Use the following connector and cable to assemble the cable. The CN13 connector kit includes one case and one connector.

Connector Kit Model	Case		Connector	
	Model	Qty	Model	Qty
JZSP-CSI9-1-E	10350-52Z0-008*	1 set	10150-3000PE* (Soldered)	1

\* : Manufactured by Sumitomo 3M Ltd.

#### · Cable Size

Item	Specifications
Cable	Use twisted-pair or twisted-pair shielded wire.
Applicable Wires	AWG 24, 26, 28, 30
Cable Finished Diameter	16 dia. max.

#### · Dimensional Drawings of Case

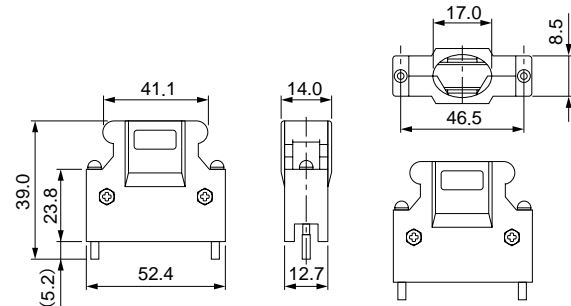

#### · Dimensional Drawings of Connector

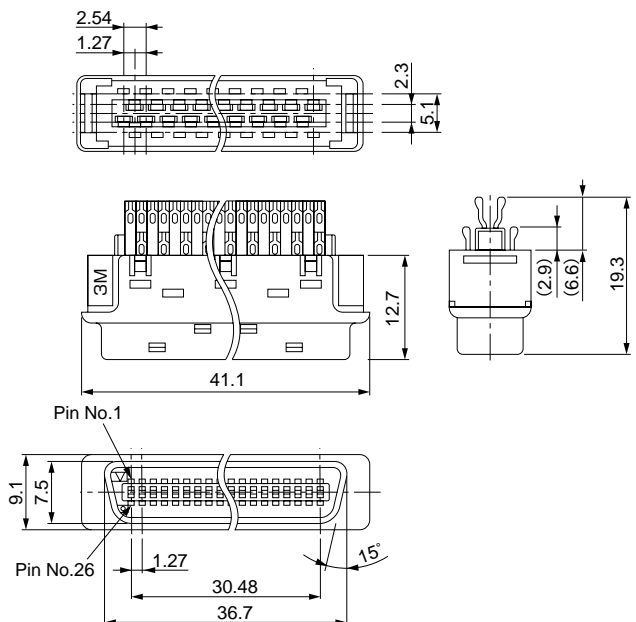

## Selecting Cables

### (2) Connector Terminal Converter Unit for CN13

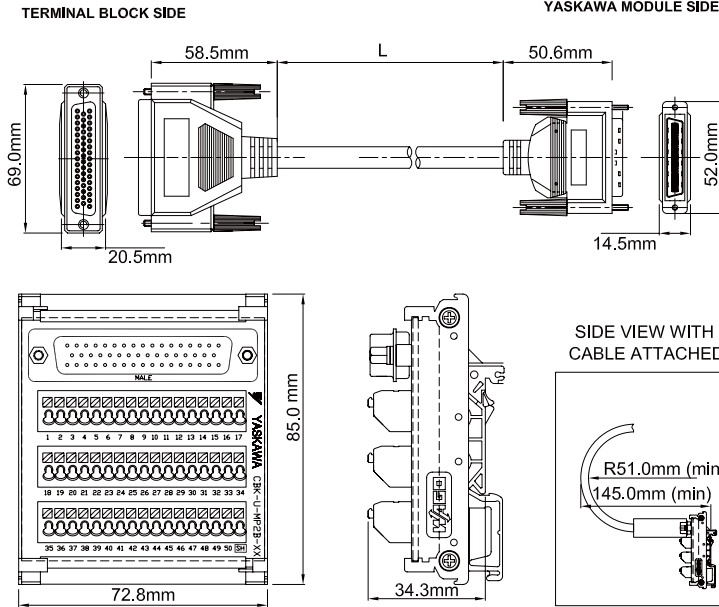

ITEM#	L = LENGTH (mm)
CBK-U-MP2B-A5	500 +/- 38.1
CBK-U-MP2B-01	1000 +/- 38.1
CBK-U-MP2B-03	3000 +/- 38.1

CABLE SPECIFICATION (mm)	
OUTER DIAMETER	8.5 +/- 0.1mm
BENDING RADIUS	6 x O.D. MINIMUM 15 x O.D. FOR LONG TERM RELIABILITY

CBK-U-MP2B-XX Function Chart for MP2600iec

Pin No.	Signal Name	I/O	Function
1	AO	O	Analog output
2	AI	I	Analog input
3	-	-	-
4	PA+	I	Phase A pulse (+)
5	PA-	I	Phase A pulse (-)
6	GND	P	Encoder input ground
7	BAT+	P	Controller SRAM Battery (+)
8	-	-	-
9	PILC5V	I	Phase-C latch pulse (-) for 5VDC input
10	PILC24V	I	Phase-C latch pulse (-) for 24VDC input
11	DO 00-	O	Digital output 0 (-)
12	DO 02-	O	Digital output 2 (-)
13	DICOM	I	Digital input common
14	DI 00	I	Digital input 0
15	DI 02	I	Digital input 2
16	DI 04	I	Digital input 4
17	DI 06	I	Digital input 6
18	DO 04-	O	Digital output 4 (-)
19	DO 06-	O	Digital output 6 (-)
20	-	-	-
21	DO 00+	O	Digital output 0 (+)
22	DO 02+	O	Digital output 2 (+)
23	DO 04+	O	Digital output 4 (+)
24	DO 06+	O	Digital output 6 (+)
25	-	-	-
26	AO GND	O	Analog output ground
27	AI GND	I	Analog input ground
28	-	-	-
29	PB+	I	Phase B pulse (+)
30	PB-	I	Phase B pulse (-)
31	GND	P	Encoder input ground
32	BAT-	P	Controller SRAM Battery (-)
33	-	-	-
34	PILC12V	I	Phase-C latch pulse (-) for 12VDC input
35	PIL	I	Phase-C latch pulse (+)
36	DO 01-	O	Digital output 1 (-)
37	DO 03-	O	Digital output 3 (-)
38	DICOM	I	Digital input common
39	DI 01	I	Digital input 1 - shared with pulse latch input
40	DI 03	I	Digital input 3
41	DI 05	I	Digital input 5
42	DI 07	I	Digital input 7
43	DO 05-	O	Digital output 5 (-)
44	DO 07-	O	Digital output 7 (-)
45	-	-	-
46	DO 01+	O	Digital output 1 (+)
47	DO 03+	O	Digital output 3 (+)
48	DO 05+	O	Digital output 5 (+)
49	DO 07+	O	Digital output 7 (+) - shared w/ position agreement COIN signal
50	-	-	-

I = Input, O = Output, P = Power

### (3) Flying Lead Cable for CN13

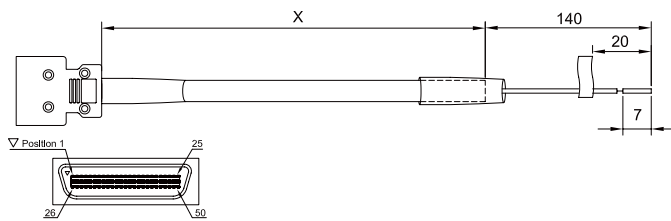

ITEM NUMBER	X = LENGTH (mm)
CFC-U-MP2B-A5	500
CFC-U-MP2B-01	1000
CFC-U-MP2B-03	3000

CABLE SPECIFICATION (mm)	
OUTER DIAMETER	8.1
BENDING RADIUS	12 O.D.

CFC-U-MP2B-XX Function Chart for MP2600iec

Pin No.	Color (Solid/Band)	Signal Name	I/O	Function
1	BLK/RED	AO	O	Analog output
2	BLK/WHT	AI	I	Analog input
3	RED/GRN	-	-	-
4	BLK/BLU	PA+	I	Phase A pulse (+)
5	BLU/BLK	PA-	I	Phase A pulse (-)
6	RED/BLU	GND	P	Encoder input ground
7	RED/WHT	BAT+	P	Controller SRAM Battery (+)
8	BLK/GRN	-	-	-
9	BLK/YEL	PILC5V	I	Phase-C latch pulse (-) for 5VDC input
10	BLK/ORG	PILC24V	I	Phase-C latch pulse (-) for 24VDC input
11	RED/YEL	DO 00-	O	Digital output 0 (-)
12	RED/GRN	DO 02-	O	Digital output 2 (-)
13	RED/ORG	DICOM	I	Digital input common
14	GRN/WHT	DI 00	I	Digital input 0
15	GRN/BLU	DI 02	I	Digital input 2
16	GRN/YEL	DI 04	I	Digital input 4
17	GRN/BRN	DI 06	I	Digital input 6
18	GRN/ORG	DO 04-	O	Digital output 4 (-)
19	WHT/BLU	DO 06-	O	Digital output 6 (-)
20	WHT/YEL	-	-	-
21	YEL/RED	DO 00+	O	Digital output 0 (+)
22	BRN/RED	DO 02+	O	Digital output 2 (+)
23	ORG/GRN	DO 04+	O	Digital output 4 (+)
24	BLU/WHT	DO 06+	O	Digital output 6 (+)
25	WHT/BRN	-	-	-
26	RED/BLK	AO GND	O	Analog output ground
27	WHT/BLK	AI GND	I	Analog input ground
28	GRN/RED	-	-	-
29	BLK/BRN	PB+	I	Phase B pulse (+)
30	BRN/BLK	PB-	I	Phase B pulse (-)
31	BLU/RED	GND	P	Encoder input ground
32	WHT/RED	BAT-	P	Controller SRAM Battery (-)
33	GRN/BLK	-	-	-
34	ORG/BLK	PILC12V	I	Phase-C latch pulse (-) for 12VDC input
35	YEL/BLK	PIL	I	Phase-C latch pulse (+)
36	WHT/ORG	DO 01-	O	Digital output 1 (-)
37	BLU/YEL	DO 03-	O	Digital output 3 (-)
38	ORG/RED	DICOM	I	Digital input common
39	WHT/GRN	DI 01	I	Digital input 1 - shared with pulse latch input
40	BLU/GRN	DI 03	I	Digital input 3
41	YEL/GRN	DI 05	I	Digital input 5
42	BRN/GRN	DI 07	I	Digital input 7
43	BLU/BRN	DO 05-	O	Digital output 5 (-)
44	BLU/ORG	DO 07-	O	Digital output 7 (-)
45	YEL/WHT	-	-	-
46	ORG/WHT	DO 01+	O	Digital output 1 (+)
47	YEL/BLU	DO 03+	O	Digital output 3 (+)
48	BRN/BLU	DO 05+	O	Digital output 5 (+)
49	ORG/BLU	DO 07+	O	Digital output 7 (+) - shared w/ position agreement COIN signal
50	BRN/WHT	-	-	-

I = Input, O = Output, P = Power



# Sigma-5 Indexer Option

The Sigma-5 SERVOPACK with indexer option provides point to point positioning capability without complex programming. With this plug-and-play system, even the automation novice will be able to develop a high performance application solution with minimal effort..

- The configuration tool SigmaWin+ provides a wizard that will interact with you in a dialog format to help you setup and change the settings for your application.
- Up to 256 positioning points can be programmed in an easy to edit program table.
- A wide range of functions such as positioning, jogging, homing, registration, backlash compensation, and programmable signal outputs are available.
- The amplifier package comes with 19 digital inputs and 16 digital outputs.
- Interface with host controller or PLC via discrete I/O or ASCII serial commands (RS-422 or RS-485).

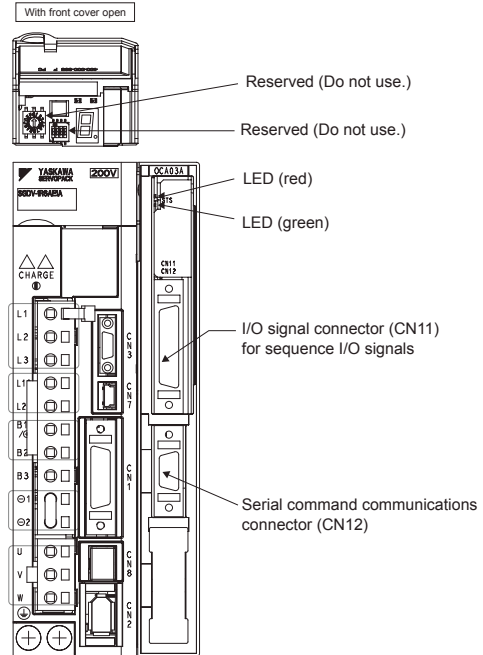

## ● External Dimensions Units: mm

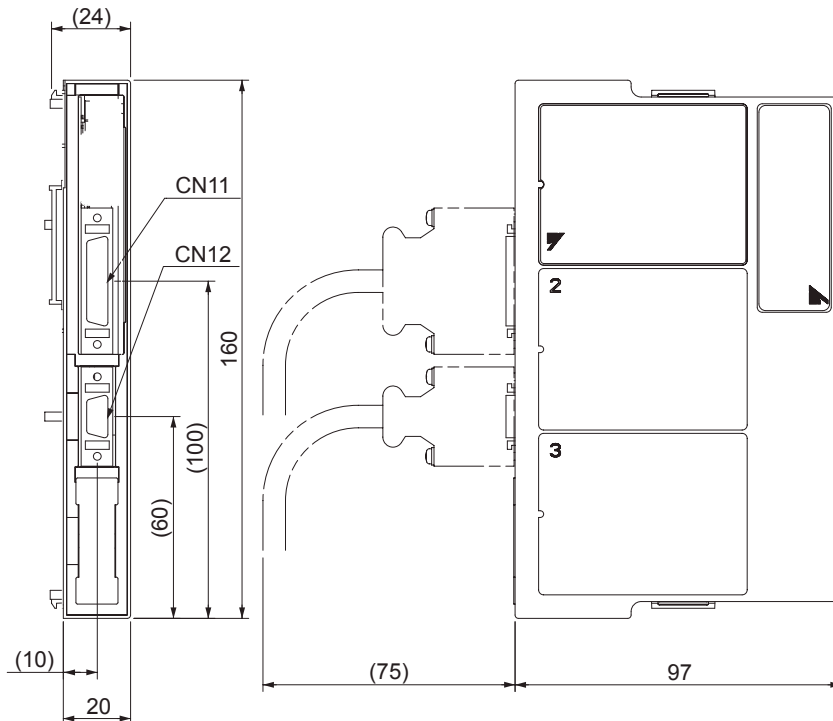

Dimensions in mm.

## Specifications of the Indexer Module

## ● INDEXER Module

Items		Specifications			
Control Method	Program Table Method	Program table positioning in which steps are executed sequentially by commands given through contact input or serial communications Positioning in which station numbers are specified by commands given through contact input or serial communications			
		Max. Number of Steps	256		
		Max. Number of Tables	256		
	Max. Number of Stations	256			
	Serial Communications Method	Serial command by 1-channel ASCII code Communications specifications: RS-422/485 (50 m max.) Connection topology: Multi-drop connection (16 axes max.) Baud rate: 9600, 19200, 38400 bps			
Other Functions		Registration (positioning by external signal), homing			
Display	LED	Lit during parameter setting, monitoring, executing utility functions, etc.			
I/O Signal	Input	SERVOPACK End	<ul style="list-style-type: none"> <li>Servo ON (/S-ON)</li> <li>Forward run prohibited (P-OT), reverse run prohibited (N-OT)</li> <li>Homing deceleration limit switch (/DEC)</li> <li>Alarm reset (/ALM-RST)</li> <li>Registration latch (/RGRT)</li> </ul>		
		Module End	Mode selection (/MODE0/1)		
			<table border="1"> <thead> <tr> <th>Mode 0</th> <th>Mode 1</th> </tr> </thead> <tbody> <tr> <td> <ul style="list-style-type: none"> <li>Starts or interrupts program table operation (/START-STOP)</li> <li>Resets program table operation (/PGMRES)</li> <li>Program table selection 0 (/SEL0) to Program table selection 7 (/SEL7)</li> </ul> </td> <td> <ul style="list-style-type: none"> <li>Starts homing (/HOME)</li> <li>Starts forward JOG operation (/JOGP)</li> <li>Starts reverse JOG operation (/JOGN)</li> <li>JOG speed table selection 0 (/JOG0) to JOG speed table selection 3 (/JOG3)</li> </ul> </td> </tr> </tbody> </table>	Mode 0	Mode 1
	Mode 0	Mode 1			
	<ul style="list-style-type: none"> <li>Starts or interrupts program table operation (/START-STOP)</li> <li>Resets program table operation (/PGMRES)</li> <li>Program table selection 0 (/SEL0) to Program table selection 7 (/SEL7)</li> </ul>	<ul style="list-style-type: none"> <li>Starts homing (/HOME)</li> <li>Starts forward JOG operation (/JOGP)</li> <li>Starts reverse JOG operation (/JOGN)</li> <li>JOG speed table selection 0 (/JOG0) to JOG speed table selection 3 (/JOG3)</li> </ul>			
	Output	SERVOPACK End	<ul style="list-style-type: none"> <li>Servo alarm (ALM)</li> <li>Error/warning (/WARN)</li> <li>Braking (/BK)</li> </ul>		
Module End		<ul style="list-style-type: none"> <li>Servo ready (/S-RDY)</li> <li>Alarm code output 0 to 2 (ALO0 to ALO2)</li> </ul>			
		<ul style="list-style-type: none"> <li>Positioning completed (/INPOSITION)</li> <li>Programmable output 0 to 7 (/POUT0 to /POUT7)</li> </ul>			

## Program Table Functions

Function	Setting Range	Setting Unit	Description
PGMSTEP	Program step	-	Program step number (0 to 255)
POS	Target position	-99,999,999 to +99,999,999	Reference unit Specifies the target position. Absolute position (A), relative distance (I), infinite length (INFINITE), Stop (STOP), no motion command (-)
SPD	Positioning speed	1 to 99,999,999	×1000 reference units/min Specifies the positioning speed.
RDST	External positioning distance	0 to 99,999,999	Reference unit Specifies registration distance. For no registration, set "-".
RSPD	External positioning speed	1 to 99,999,999	×1000 reference units/min Specifies registration speed.
ACC	Acceleration	1 to 99,999,999	×1000 reference units/min/ms Specifies acceleration for positioning or registration. To continue with the acceleration specified in the previously executed program step, set "-".
DEC	Deceleration	1 to 99,999,999	×1000 reference units/min/ms Specifies deceleration for positioning or registration. To continue with the deceleration specified in the previously executed program step, set "-".
POUT	Programmable output signals	-	- Specifies the operation of programmable output signals /POUT0 to /POUT7. Active (A), inactive (N), ZONE signal (Z), maintain previous condition ( : )
EVENT	Pass condition	0 to 99,999 (Waiting time settings)	ms Sets waiting time (Tn) and any one of the following in tandem: Positioning completion signal (I), position reference distribution completed signal (D), positioning near signal (N), or selection signal (SELn)
LOOP	Number of executions	1 to 99,999	- Specifies the number of executions from positioning start to pass condition (EVENT).
NEXT	Program step to be executed next	0 to 255	- Specifies the program step (PGMSTEP) to be executed next. To end program table operation, set "END".

## Selecting Cables

### ● Cables for CN11 CN12 (INDEXER Module)

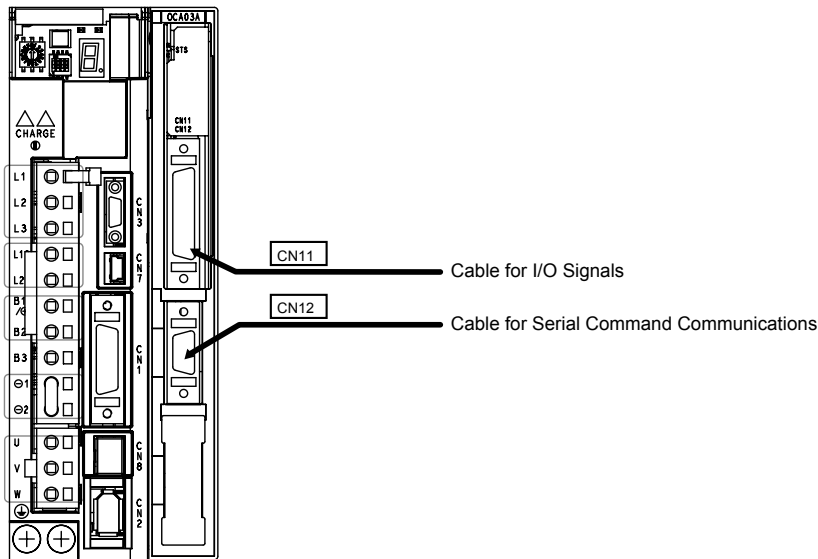

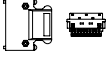
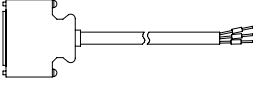
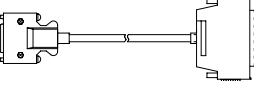
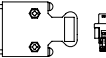
Name		Length	Order No.	Specifications	Details
<span style="border: 1px solid black; padding: 2px;">CN11</span> Cable for I/O Signals	Connector Kit		DP9420007-E		(1)
	Cable with Loose wire at One End	1 m	JZSP-CVI01-1-E		(2)
		2 m	JZSP-CVI01-2-E		
		3 m	JZSP-CVI01-3-E		
	Cable with Terminal Block at One End	0.5 m	JUSP-TA36V-E		(3)
		1 m	JUSP-TA36V-1-E		
2 m		JUSP-TA36V-2-E			
<span style="border: 1px solid black; padding: 2px;">CN12</span> Cable for Serial Command Communications	Connector kit <sup>*1</sup>		JZSP-CHI9-1		(4)

\*1 Use the connector kit when you make cables yourself.

# Indexer Option

## Selecting Cables

### (1) Connector Kit for CN11

Use the following connector and cable to assemble the cable. The CN11 connector kit includes one case and one connector.

Connector Kit Model	Case		Connector	
	Model	Qty	Model	Qty
DP9420007-E	10336-52A0-008*	1 set	10136-3000PE* (Soldered)	1

\* : Manufactured by Sumitomo 3M Ltd.

#### • Cable Size

Item	Specifications
Cable	Use twisted-pair or twisted-pair shielded wire.
Applicable Wires	AWG24, 26, 28, 30
Cable Finished Diameter	16 dia. max.

#### • External Dimensions of Case (Units: mm)

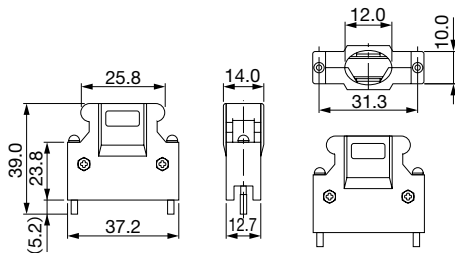

#### • External Dimensions of Connector (Units: mm)

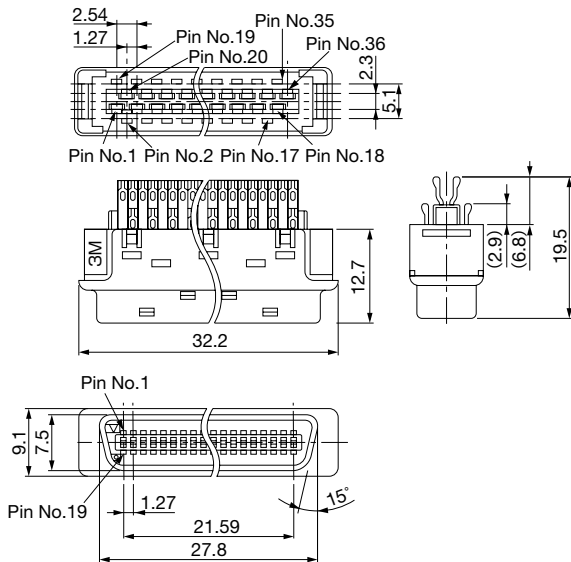

### (2) Cable with Loose Wires at One End for CN11 External Dimensions of Cable (Units: mm)

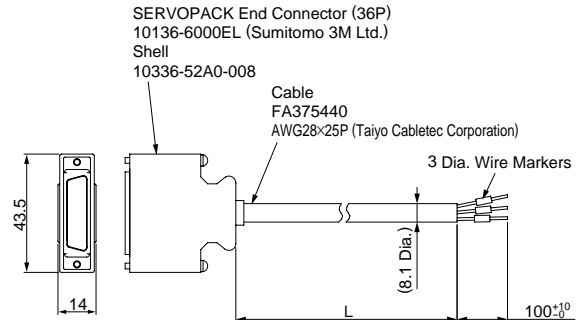

Model	Cable Length
JZSP-CVI01-1-E	1 m
JZSP-CVI01-2-E	2 m
JZSP-CVI01-3-E	3 m

### • Cable with Loose Wires at One End for CN11 Connection Diagram of JZSP-CVI01-□-E Cable

SERVOPACK End					Host Controller End
Pin No.	Signal	Wire Color	Marking Color	Marking Dots	
1	COM+	Orange	Red	1	Lead Marker 1
2	-	-	-	-	-
3	/MODE0/1	Gray	Red	1	3
4	-	-	-	-	-
5	STR-STP /HOME	White	Red	1	5
6	-	-	-	-	-
7	PGMRES /JOGP	Yellow	Red	1	7
8	-	-	-	-	-
9	SEL0 /JOGN	Pink	Red	1	9
10	-	-	-	-	-
11	SEL1 /JOG0	Orange	Red	2	11
12	-	-	-	-	-
13	SEL2 /JOG1	Gray	Red	2	13
14	SEL5	White	Red	2	14
15	SEL3 /JOG2	Yellow	Red	2	15
16	SEL6	Pink	Red	2	16
17	SEL4 /JOG4	Orange	Red	3	17
18	SEL7	Gray	Red	3	18
19	INPOS+	White	Red	3	19
20	INPOS-	White	Black	3	20
21	POUT0+	Yellow	Red	3	21
22	POUT0-	Yellow	Black	3	22
23	POUT1+	Pink	Red	3	23
24	POUT1-	Pink	Black	3	24
25	POUT2+	Orange	Red	4	25
26	POUT2-	Orange	Black	4	26
27	POUT3+	Gray	Red	4	27
28	POUT3-	Gray	Black	4	28
29	POUT4+	White	Red	4	29
30	POUT4-	White	Black	4	30
31	POUT5+	Yellow	Red	4	31
32	POUT5-	Yellow	Black	4	32
33	POUT6+	Pink	Red	4	33
34	POUT6-	Pink	Black	4	34
35	POUT7+	Orange	Red	5 or more	35
36	POUT7-	Orange	Black	5 or more	36
Case	Shield	-	-	-	-

↗ : Represents twisted-pair wires.



## Selecting Cables

### (3) Cable with Terminal Block at One End (for CN11)

- Configurations

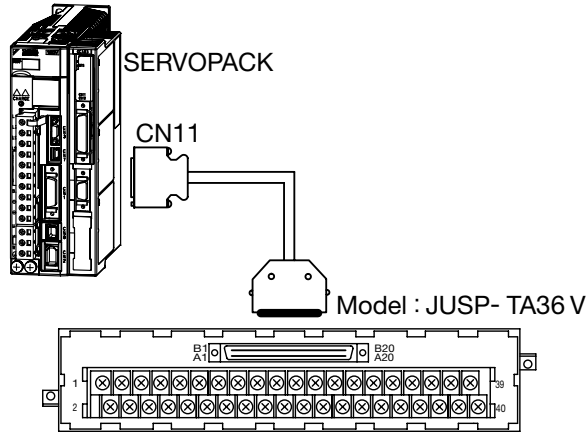

- External Dimensions of Terminal Block (Units: mm)

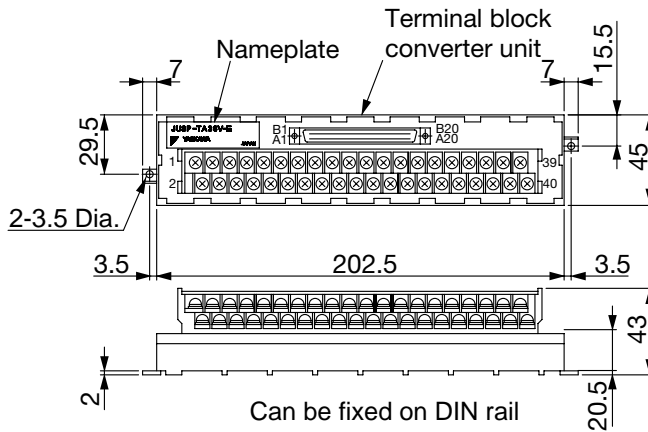

- External Dimensions of Cable (Units: mm)

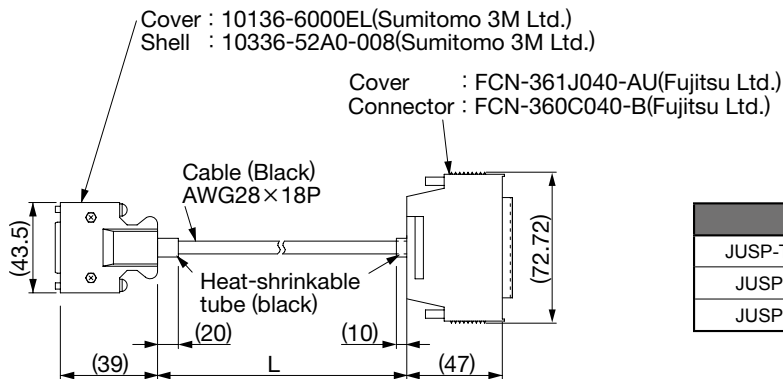

Model	Cable Length (L)	Approx. Mass
JUSP-TA36V-E	0.5 m	100 g
JUSP-TA36V-1-E	1 m	200 g
JUSP-TA36V-2-E	2 m	400 g

Note: The pin number in the SERVOPACK connector and the pin number in the terminal block are the same.  
Pin numbers 1 to 36 are used in the terminal block.

Do not use a pin number of 37 or higher.

If assembling cables, refer to the •Cable with Loose Wires at One End for CN11 Connection Diagram of JZSP-CV101-□-E Cable on the previous page.

## Selecting Cables

### (4) Connector Kit for CN12

Use the following connector and cable to assemble the cable. The CN12 connector kit includes one case and one connector.

Connector Kit Model	Case		Connector	
	Model	Qty	Model	Qty
JZSP-CHI9-1	10314-52A0-008*	1 set	10114-3000PE* (Soldered)	1

\* : Manufactured by Sumitomo 3M Ltd.

#### • Cable Size

Item	Specifications
Cable	Use twisted-pair or twisted-pair shielded wire.
Applicable Wires	AWG24, 26, 28, 30
Cable Finished Diameter	16 dia. max.

#### • External Dimensions of Connector (Units: mm)

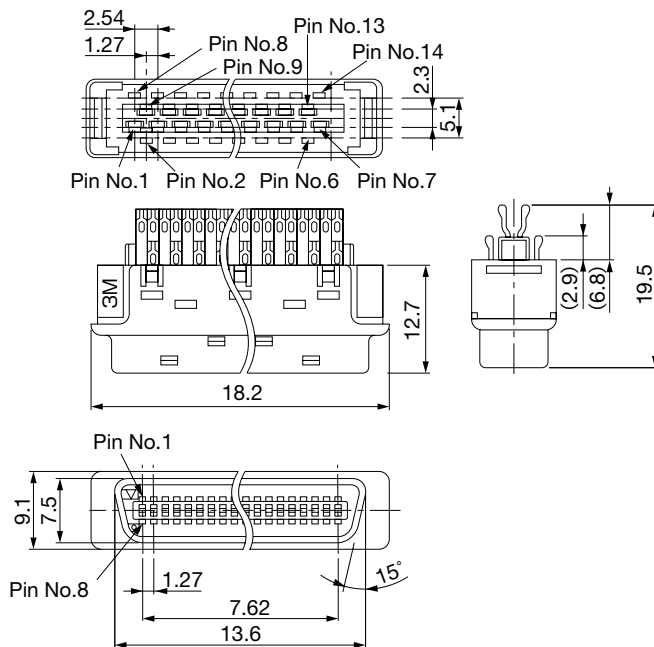

#### • External Dimensions of Case (Units: mm)

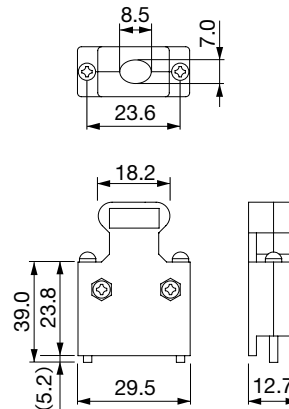



# Sigma-5 Functional Safety Option

The functional safety option for the Sigma-5 SERVOPACK provides the functionality necessary to handle the different safe machine states required in your application

- The STO (Safe Torque Off) function is integrated into the standard SERVOPACK.
- Additional functions SS1 (Safe Stop 1), SS2 (Safe Stop 2), and SLS (Safe Limited Speed) can be accessed by choosing the advanced safety option

Safe Torque Off (STO)

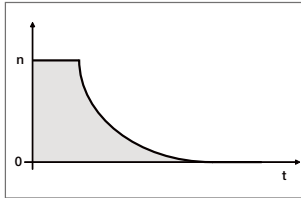

Safe Stop 1 (SS1)

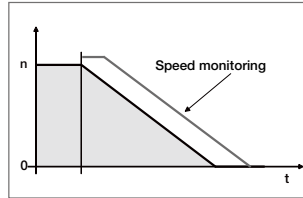

Safe Stop 2 (SS2)

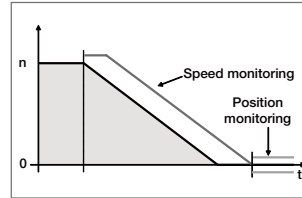

Safely Limited Speed (SLS)

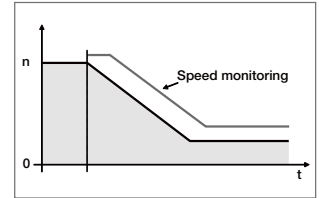

The Sigma-5 SERVOPACKs are certified by TUV SUD and comply with the following safety standards:



Description	Standard	Performance
Safety Integrity Level	IEC 61508	SIL 2
	IEC 62061	SILCL2
Performance Level	EN ISO 13849-1	PL-d
Stop functions	IEC 60204-1	Stop category 0/1/2
Functional Safety	IEC 61800-5-2	STO/SS1/SS2/SLS

● External Dimensions Units: mm

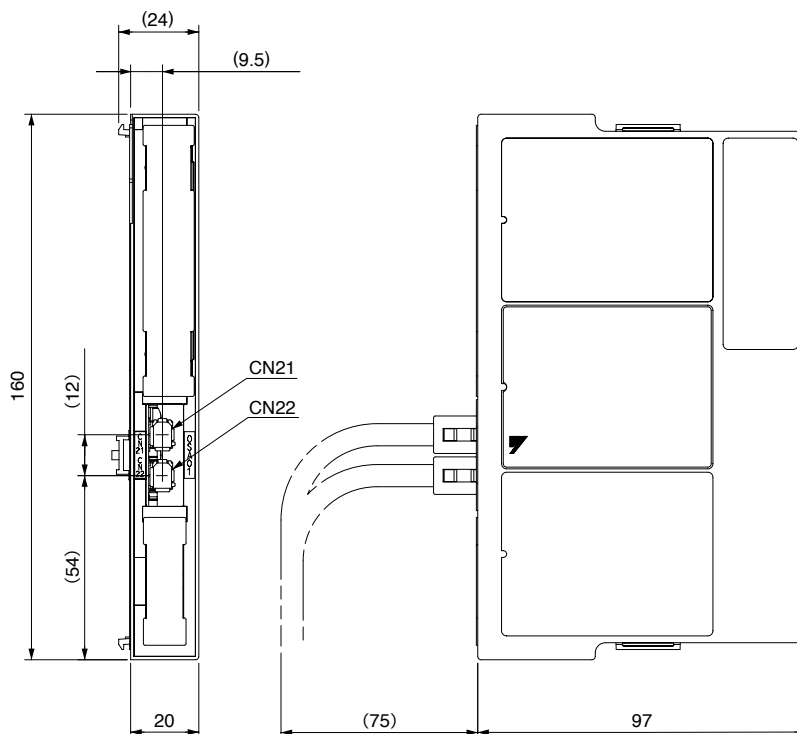

Approx. Mass: 0.11 kg

## Specifications of the Functional Safety Option

Items		Specifications		
Operating Conditions	Ambient Temperature	0 to +55°C		
	Storage Temperature	-20 to +85°C		
	Ambient Humidity	90% RH or less	With no freezing or condensation	
	Storage Humidity	90% RH or less		
	Vibration Resistance	4.9 m/s <sup>2</sup>		
	Shock Resistance	19.6 m/s <sup>2</sup>		
	Protection Class	IP10	An environment that satisfies the following conditions. <ul style="list-style-type: none"> <li>• Free of corrosive or flammable gases</li> <li>• Free of exposure to water, oil, or chemicals</li> <li>• Free of dust, salts, or iron dust</li> </ul>	
	Pollution Degree	2		
	Altitude	1000 m or less		
	Others	Do not use SERVOPACKs in the following locations: <ul style="list-style-type: none"> <li>• Locations subject to static electricity noise, strong electromagnetic/magnetic fields, radioactivity</li> </ul>		
Compliance with North American Safety Standards, European Directives, and Safety Standards (SERVOPACK + Safety Module)				
North American Safety Standards		UL508C (E147823)		
European Directives	Machinery Directive (2006/42/EC)	EN ISO 13849-1: 2008 EN 954-1		
	EMC Directive (2004/108/EC)	EN 55011/A2 group 1, class A EN 61000-6-2 EN 61800-3		
	Low Voltage Directive (2006/95/EC)	EN 50178 EN 61800-5-1		
Safety Standards	Safety of Machinery	EN ISO 13849-1, EN 954-1, IEC 60204-1		
	Functional Safety	IEC 61508-1 to -7, IEC 62061, IEC 61800-5-2		
	EMC Directive	IEC 61326-3-1		
Safety Function		IEC 61800-5-2	IEC 60204-1	
		Safe Torque Off (STO)	Stop Category 0	
		Safe Stop 1 (SS1)	Stop Category 1	
		Safe Stop 2 (SS2)	Stop Category 2	
		Safely Limited Speed (SLS)		
	Number of Function	2		
	Safety Function A	Input signal: Two channels (redundant signals), output signal: one channel		
Safety Function B	Input signal: Two channels (redundant signals), output signal: one channel			
Safe Performance				
	Safety Integrity Level	SIL2, SILCL2		
	Probability of Dangerous Failure per Hour	PFH $\leq$ 3.3 [1/h]		
	Category	Cat3		
	Performance Level	PLd (Category 2)		
	Mean Time to Dangerous Failure of Each Channel	MTTFd: High		
	Average Diagnostic Coverage	DCave: Medium		
	Proof Test Interval	10 years		

# Selecting Cables

● **CN21** **CN22** Cable for Functional Safety Option

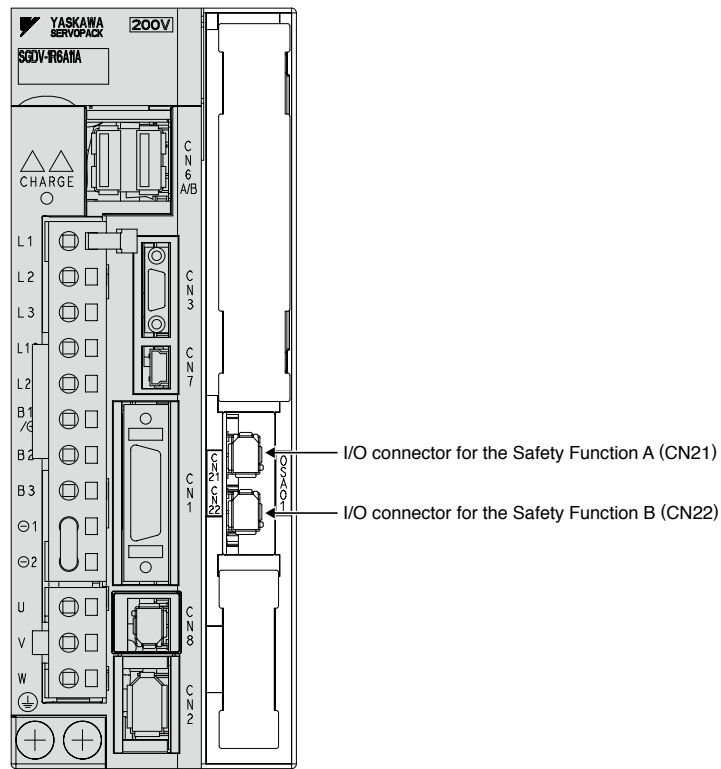

Name	Length	Order No.	Specifications	Details
<b>CN21</b> <b>CN22</b> Cable with Connector <sup>*1</sup>	3 m	JZSP-CVH03-03-E		(1)
<b>CN21</b> <b>CN22</b> Cable for Functional Safety Option	Connector Kit <sup>*2</sup>	Contact Tyco Electronics AMP K.K. Product name: Industrial Mini I/O D-shape Type1 Plug Connector Kit Model: 2013595-1		

\*1: When using the safety function, connect this cable to the safety devices.  
 \*2: Use the connector kit when you make cables yourself.

(1) Cable with Connector for CN21 and CN22  
 (Model: JZSP-CVH03-03-E)

• External Dimensions (Units: mm)

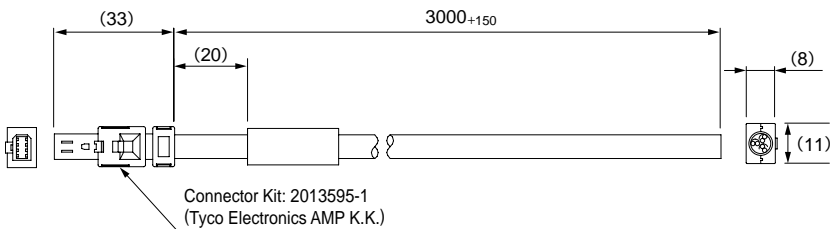

• Specifications

Pin No.	Signal	Lead Color	Marking Color
1	Not used	-	-
2	Not used	-	-
3	/SRI-□1-	White	Black
4	/SRI-□1+	White	Red
5	/SRI-□2-	Gray	Black
6	/SRI-□2+	Gray	Red
7	EDM-□-	Orange	Black
8	EDM-□+	Orange	Red

Note: The signal name varies in accordance with the connector used.

Connector CN21: □=A  
 Connector CN22: □=B





# Wiring Main Circuit and Peripheral Devices

## Wiring Main Circuit

### ● Typical Main Circuit Wiring Examples

This section describes the typical main circuit wiring examples.

### ⚠ WARNING

After turning OFF the power, do not touch the power terminals while charge indicator is still ON. High residual voltage may still remain in the SERVOPACK. When the voltage is discharged, the charge indicator will turn OFF. Make sure the charge indicator is OFF before starting wiring or inspection.

#### ● Single-phase 100 V

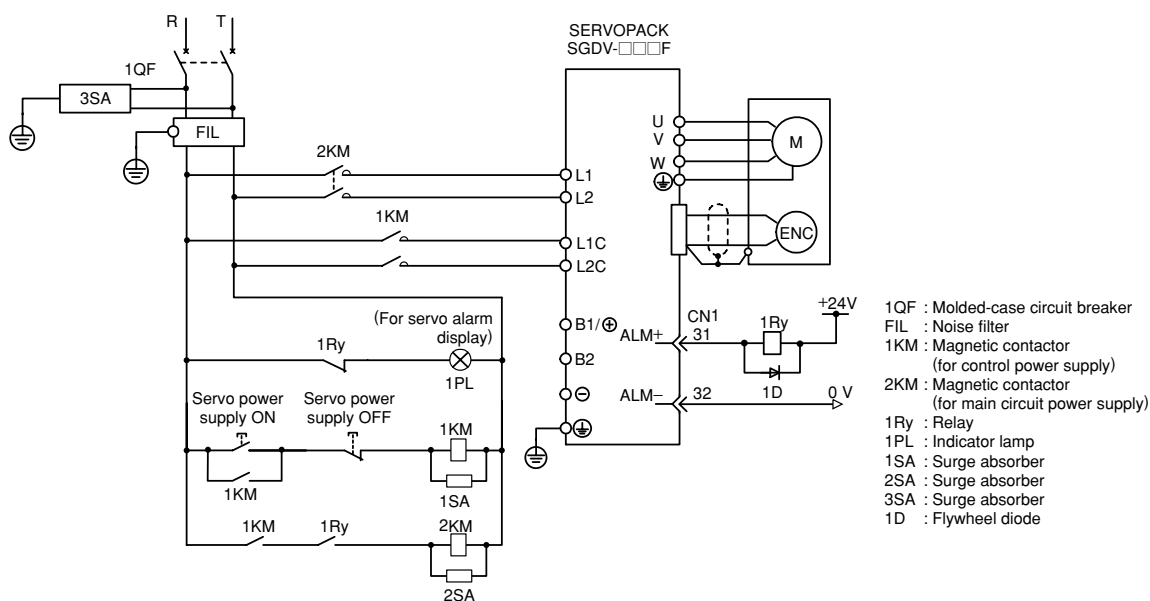

#### ● Three-phase 200 V

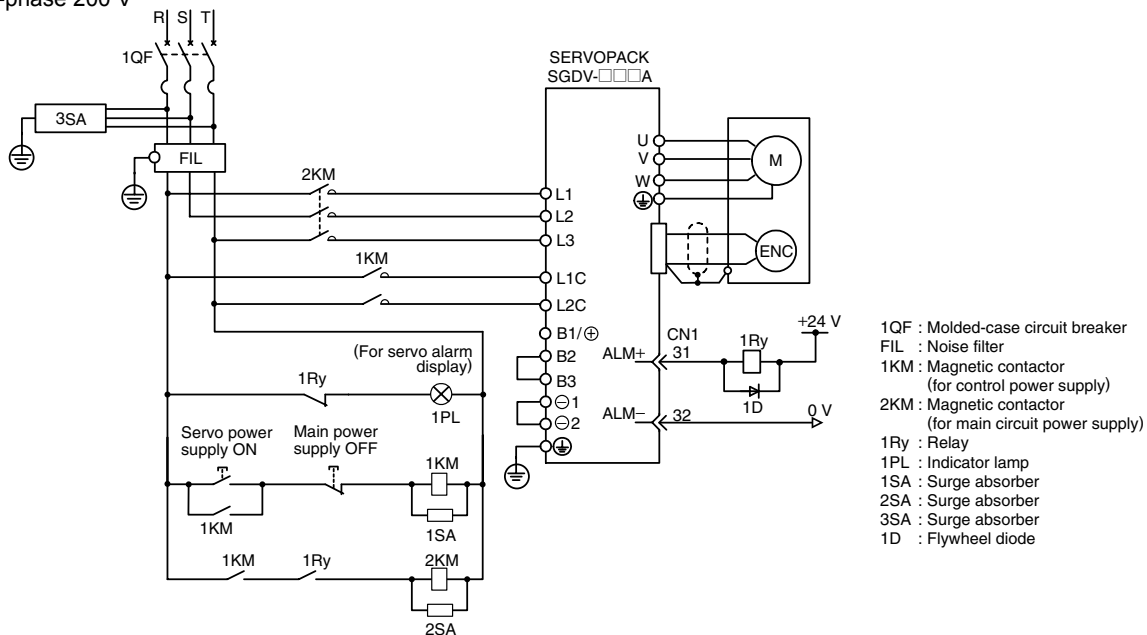

Note: Every SERVOPACK of SGDV-470A, -550A, -590A and -780A requires a specified external regenerative unit.

## Wiring Main Circuit

- Three-phase 400 V

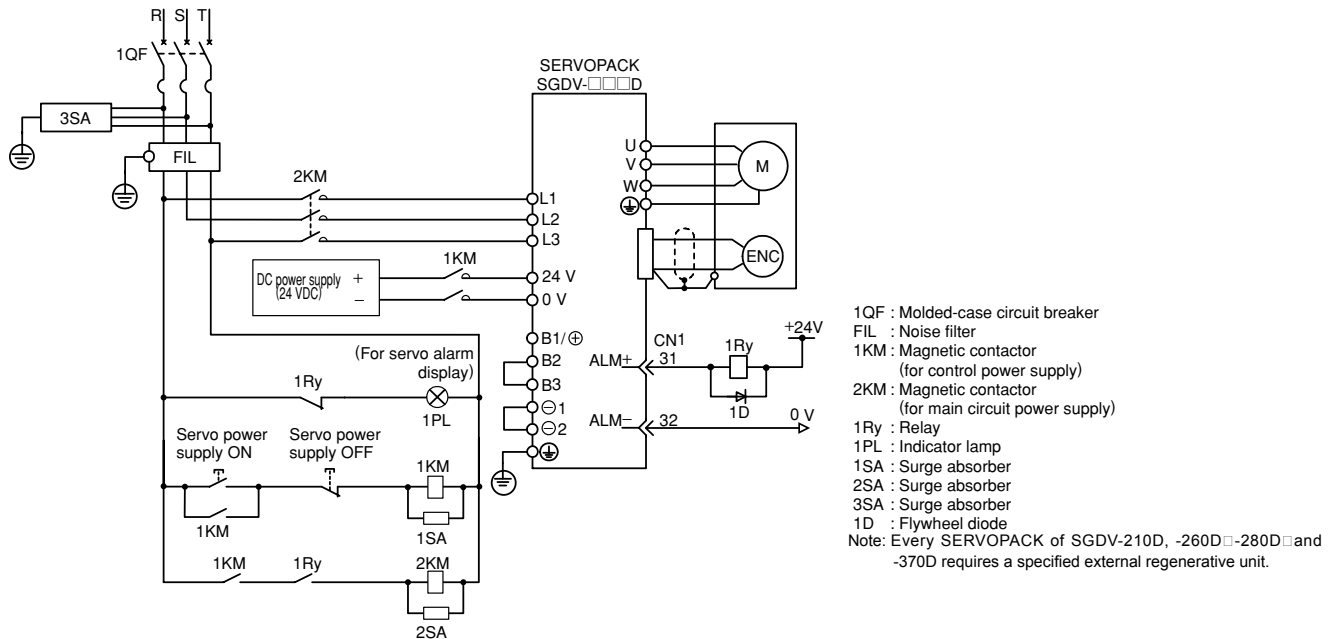

## ● General Precautions for Wiring

### IMPORTANT

- Use a molded-case circuit breaker (QF) or fuse to protect the Main Circuit.  
 The SERVOPACK connects directly to a commercial power supply; it is not isolated by a transformer or other device.  
 Always use a molded-case circuit breaker (QF) or fuse to protect the servo system from accidents involving different power system voltages or other accidents.
- Install a ground fault detector.  
 The SERVOPACK does not have a built-in protective circuit for grounding. To configure a safer system, install a ground fault detector against overloads and short-circuiting, or install a ground fault detector combined with a molded-case circuit breaker.
- Do not turn power ON and OFF frequently.  
 The power supply in the SERVOPACK contains a capacitor, which causes a high charging current to flow when power is turned ON. Frequently turning power ON and OFF will cause the main circuit elements in the SERVOPACK to deteriorate.

To ensure safe, stable application of the servo system, observe the following precautions when wiring.

Observe the following precautions when wiring the main circuit.

- Use shielded twisted-pair wires or shielded multi-core twisted-pair wires for signal lines and encoder lines.
- The maximum wiring length is 3 m for signal lines and 50 m for encoder lines.

Observe the following precautions when wiring the ground.

- Use a cable as thick as possible (at least 2.0 mm<sup>2</sup>)
- Ground the 100-V and the 200-V SERVOPACK to a resistance of 100 Ω or less. Ground the 400-V SERVOPACK to a resistance of 10 Ω or less.
- Be sure to ground at only one point.
- Ground the servomotor directly if the servomotor is insulated from the machine.

The signal cable conductors are as thin as 0.2 mm or 0.3 mm. Do not impose excessive bending force or tension.

## ● Precautions When Using the SERVOPACK with a DC Power Input

When using the SERVOPACK with a DC power input, refer to 3.1.5 Precautions When using the SERVOPACK with a DC power input on "AC Servodrive  $\Sigma$ -V Series USER'S MANUAL Design and Maintenance." (manual no. SIEP S800000 45)



## Wiring Main Circuit

### ● Precautions When Using More Than One SERVOPACK

This section shows an example of the wiring when more than one SERVOPACK is used and the precautions.

#### ● Wiring Example

Connect the alarm output (ALM) terminals for the three SERVOPACKs in series to enable alarm detection relay 1RY to operate.

When a SERVOPACK alarm is activated, the ALM output signal transistor is turned OFF.

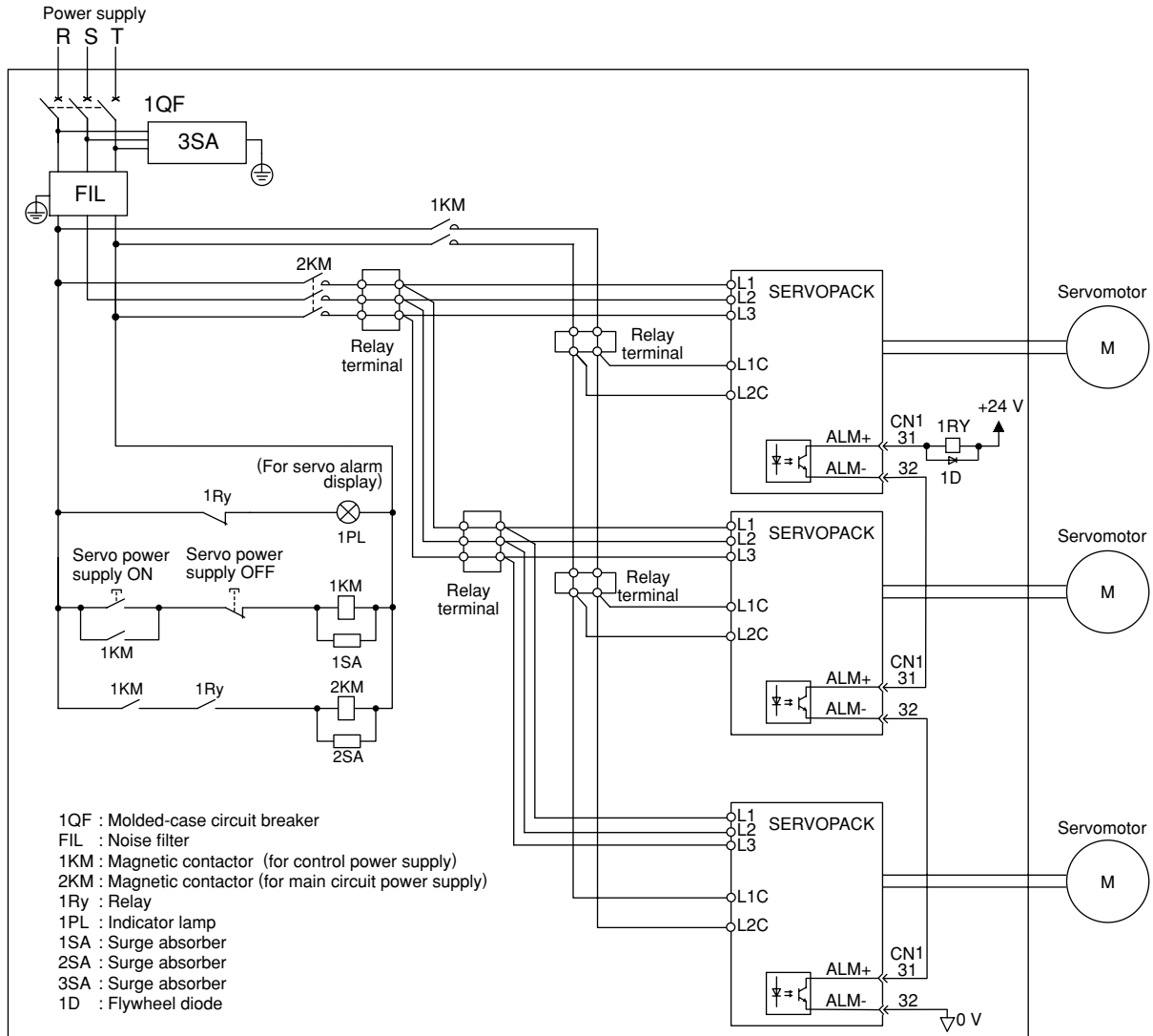

#### ● Precautions

Multiple servos can share a single molded-case circuit breaker (QF) or noise filter. Always select a QF or noise filter that has enough capacity for the total power capacity (load conditions) of those servos.

## SERVOPACK Main Circuit Wire

## ● Single-phase, 100 V

Cables	Terminal Symbol	SERVOPACK Model SGD-V-			
		R70F	R90F	2R1F	2R8F
Main Circuit Power Cable	L1, L2	HIV1.25		HIV2.0	
Servomotor Main Circuit Cable	U, V, W	HIV1.25			
Control Power Cable	L1C, L2C	HIV1.25			
External Regenerative Resistor Cable	B1(⊕), B2	HIV1.25			
Ground Cable	⊖	HIV2.0 min.			

## ● Three-phase, 200 V

Cables	Terminal Symbol	SERVOPACK Model SGD-V-														
		R70A	R90A	1R6A	2R8A	3R8A	5R5A	7R6A	120A	180A	200A	330A	470A	550A	590A	780A
Main Circuit Power Cable	L1, L2, L3	HIV1.25			HIV2.0				HIV3.5		HIV5.5	HIV8	HIV14	HIV22		
Servomotor Main Circuit Cable	U, V, W	HIV1.25			HIV2.0				HIV3.5	HIV5.5	HIV8.0	HIV14		HIV22		
Control Power Cable	L1C, L2C	HIV1.25														
External Regenerative Resistor Cable	B1(⊕), B2	HIV1.25						HIV2.0	HIV3.5	HIV5.5	HIV8		HIV22			
Ground Cable	⊖	HIV2.0 min.														

## ● Three-phase, 400 V

Cables	Terminal Symbol	SERVOPACK Model SGD-V-										
		1R9D	3R5D	5R4D	8R4D	120D	170D	210D	260D	280D	370D	
Main Circuit Power Cable	L1, L2, L3	HIV1.25			HIV2.0		HIV3.5		HIV5.5	HIV8	HIV14	
Servomotor Main Circuit Cable	U, V, W	HIV1.25			HIV2.0		HIV3.5	HIV5.5		HIV8	HIV14	
Control Power Cable	24V, 0V	HIV1.25										
External Regenerative Resistor Cable	B1(⊕), B2	HIV1.25					HIV2.0	HIV3.5		HIV5.5	HIV8	
Ground Cable	⊖	HIV2.0 min.										

## ● Wire Type

Wire Type		Allowable Conductor Temperature °C
Code	Name	
PVC	Polyvinyl chloride insulated wire	—
IV	600 V polyvinyl chloride insulated wire	60
HIV	600 V grade heat-resistant polyvinyl chloride insulated wire	75

## ● HIV Conversion Chart

HIV	Cross-Sectional Area (mm <sup>2</sup> ) *1	AWG
HIV 1.25	1.25	16
HIV 2.0	2.0	14
HIV 3.5	3.5	12
HIV 5.5	5.5	10
HIV 8.0	8.0	8
HIV 14	14	6
HIV 22	22	4

\*1 Cross-sectional area applies to solid wires

## SERVOPACK Main Circuit Wire

The following table shows the size and allowable currents for the wires. Use a wire whose specifications meet or are less than the values in the table.

### ● 600 V grade heat-resistant polyvinyl chloride insulated wires

Nominal Cross Section Diameter mm <sup>2</sup>	AWG size	Allowable Current at Ambient Temperatures A		
		30°C	40°C	50°C
0.5	20	6.6	5.6	4.5
0.75	–	8.8	7.0	5.5
0.9	18	9.0	7.7	6.0
1.25	17 to 16	12.0	11.0	8.5
2.0	14	23	20	16
3.5	12 to 11	33	29	24
5.5	10 to 9	43	38	31
8.0	8	55	49	40
14.0	6 to 5	79	70	57
22.0	4 to 3	91	81	66

Note: The values in the table are only for reference.

#### IMPORTANT

- 1 Wire sizes are selected for three cables per bundle at 40°C ambient temperature with the rated current.
- 2 Use a wire with a minimum withstand voltage of 600 V for the main circuit.
- 3 If wires are bundled in PVC or metal ducts, take into account the reduction of the allowable current.
- 4 Use a heat-resistant wire under high ambient or panel temperatures, where polyvinyl chloride insulated wires will rapidly deteriorate.

## Molded-case Circuit Breaker and Fuse Capacity

Main Circuit Power Supply	Applicable Servomotor Max. Capacity kW	SERVOPACK Model SGD V-	Power Supply Capacity per SERVOPACK kVA	Current Capacity		Inrush Current	
				Main Circuit $A_{rms}$	Control Circuit $A_{rms}$	Main Circuit $A_{0-p}$	Control Circuit $A_{0-p}$
Single-phase 100 V	0.05	R70F	0.2	1.5	0.38	16.5	35
	0.1	R90F	0.3	2.5			
	0.2	2R1F	0.7	5			
	0.4	2R8F	1.4	10			
Three-phase 200 V	0.05	R70A	0.2	1.0	0.2	33	70
	0.1	R90A	0.3	1.0			
	0.2	1R6A	0.6	2.0			
	0.4	2R8A	1	3.0			
	0.5	3R8A	1.4	3.0			
	0.75	5R5A	1.6	6.0			
	1.0	7R6A	2.3	6.0	0.25	33	
	1.5	120A	3.2	7.3			
	2.0	180A	4	9.7			
	3.0	200A	5.9	15			
	5.0	330A	7.5	25			
	6.0	470A	10.7	29			
	7.5	550A	14.6	37			
	11	590A	21.7	54			0.45
15	780A	29.6	73				
Three-phase 400 V	0.5	1R9D	1.1	1.4	1.2	17	-
	1.0	3R5D	2.3	2.9			
	1.5	5R4D	3.5	4.3			
	2.0	8R4D	4.5	5.8	1.4	34	
	3.0	120D	7.1	8.6			
	5.0	170D	11.7	14.5			
	6.0	210D	12.4	17.4	1.5	34	
	7.5	260D	14.4	21.7			
	11	280D	21.9	31.8	1.7	68	
15	370D	30.6	43.4				

Notes: 1 To comply with the low voltage directive, connect a fuse to the input side. Select the fuse or molded-case circuit breaker for the input side from among models that are compliant with UL standards.

The table above also provides the net values of current capacity and inrush current. Select a fuse and a molded-case circuit breaker which meet the breaking characteristics shown below.

- Main circuit, control circuit: No breaking at three-times the current values of the table for 5 s.
- Inrush current: No breaking at the same current values of the table for 20 ms.

2 In accordance with UL standards, the following restrictions apply. Install fuses or circuit breakers listed in accordance with the guidelines of NEC.

SERVOPACK SGD V-	Restrictions
180A,200A	Available rated current for molded-case circuit breaker: 40 A or less
330A	<ul style="list-style-type: none"> <li>· Available rated current for non-time delay fuse: 70 A or less</li> <li>· Available rated current for time delay fuse: 40 A or less</li> <li>· Do not use single wires.</li> </ul>
470A, 550A	<ul style="list-style-type: none"> <li>· Available rated current for molded-case circuit breaker: 60A or less</li> <li>· Available rated current for non-time delay fuse: 60 A or less</li> </ul>
590A, 780A	<ul style="list-style-type: none"> <li>· Available rated current for molded-case circuit breaker: 100 A or less</li> <li>· Available rated current for non-time delay fuse or time delay fuse: 100 A or less (Available rated current for class J non-time delay or faster fuse: 125 A or less)</li> </ul>
210D, 260D	<ul style="list-style-type: none"> <li>· Available rated current for molded-case circuit breaker: 60 A or less</li> <li>· Available rated current for non-time delay fuse: 60 A or less</li> <li>· Available rated current for time delay fuse: 35 A or less</li> </ul>
280D, 370D	<ul style="list-style-type: none"> <li>· Available rated current for molded-case circuit breaker: 80 A or less</li> <li>· Available rated current for non-time delay fuse: 125 A or less</li> <li>· Available rated current for time delay fuse: 75 A or less</li> </ul>

## Noise Filters

### ● Noise Filter Selection

Main Circuit Power Supply	SERVOPACK Model SGDV-	Recommended Noise Filter			Details
		Model	Specifications	Leakage Current	
Single-phase 100 V	R70F,R90F	FN2070-6/07	Single-phase 250V 6A	0.734 mA 230VAC/50Hz	(1)
	2R1F	FN2070-10/07	Single-phase 250V 10A		
	2R8F	FN2070-16/07	Single-phase 250V 16A		
Single-phase 200 V	R70A, R90A, 1R6A	FN2070-6/07	Single-phase 250V 6A	0.734 mA 230VAC/50Hz	
	2R8A	FN2070-10/07	Single-phase 250V 10A		
	5R5A	FN2070-16/07	Single-phase 250V 16A		
	120A	FN350-30/33	Single-phase 250V 30A	5.4 mA 230VAC/50Hz	
Three-phase 200 V	R70A,R90A,1R6A 2R8A,3R8A	FN258L-7/07	Three-phase 480V 7A	0.5 mA 440VAC/50Hz	(2)
	5R5A,7R6A	FN258L-16/07	Three-phase 480V 16A	0.8 mA 440VAC/50Hz	
	120A,180A	HF3020C-UQC	Three-phase 480V 20A	10 mA 440VAC/50Hz	
	200A	HF3030C-UQC	Three-phase 480V 30A		
	330A, 470A	HF3050C-UQC	Three-phase 480V 50A		
	550A	HF3060C-UQC	Three-phase 480V 60A		
	590A, 780A	HF3100C-UQB	Three-phase 480V 100A		(3)
Three- phase 400 V	1R9D,3R5D,5R4D	FN258L-7/07	Three-phase 480V 7A	0.8 mA 440VAC/50Hz	(2)
	8R4D,120D	FN258L-16/07	Three-phase 480V 16A	160 mA 440VAC/50Hz	(3)
	170D	FMAC-0934-5010	Three-phase 480V 35A	10 mA 440VAC/50Hz	(2)
	210D, 260D	HF3050C-UQC	Three-phase 480V 50A	10 mA 440VAC/50Hz	(2)
	280D, 370D	HF3080C-UQB	Three-phase 480V 80A	10 mA 440VAC/50Hz	(3)

Note: RoHS-compliant models are not available. Contact the manufactures when in need of an RoHS-compliant model.

#### IMPORTANT

Some noise filters have large leakage currents. The grounding measures taken also affect the extent of the leakage current. If necessary, select an appropriate leakage current detector or leakage current breaker taking into account the grounding measures that are used and leakage current from the noise filter. Contact the manufacturer of the noise filter for details

## Noise Filters

- External Dimensions (Units: mm)
- (1) FN Type (by Schaffner EMC, Inc.)

Model		FN2070-6/07	FN2070-10/07	FN2070-16/07	
Dimensional Drawings					
		Connection Lead P/N/E			
External Dimensions	Code	Dimensions			
	A	113.5±1	156±1	119±0.5	
	B	57.5±1		85.5±1	
	C	45.4±1.2		57.6±1	
	D	94±1	130.5±1	98.5±1	
	F	103±0.3	143±0.3	109±0.3	
	J	25±0.2		40±0.2	
	K	8.4±0.5		8.6±0.5	
	L	32.4±0.5		-	
	M	4.4±0.1	5.3±0.1	4.4±0.1	
	N	6±0.1		7.4±0.1	
	P	0.9±0.1		1.2±0.1	
	Q	-		66±0.3	
R	-		51±0.2		
S	38±0.5		-		

Model	FN350-30/33
Dimensional Drawings	

# Noise Filters

## (2) FN Type and HF Type

Model	FN Type [by Schaffner EMC, Inc.]		HF Type [by SOSHIN ELECTRIC CO., LTD.]		
	FN258L-7/07	FN258L-16/07	HF3020C-UQC HF3030C-UQC	HF3050C-UQC HF3060C-UQC	
Dimensional Drawings					
External Dimensions mm	Code	Dimensions		Dimensions	
	A	225±1	305±1	236	256
	B	126±0.8	142±0.8	221	241
	C	50±0.6	55±0.6	206	226
	D	225±0.8	275±0.8	184	204
	E	240±0.5	290±0.5	105	115
	F	25±0.3	30±0.3	90	100
	G	6.5±0.2		76	86
	H	300±10		122	127
	J	1±0.1		5.5×7 Dia.	5.5×7 Dia.
	K	-		M5	M5
	L	9±1		M5	M5
	M	-		16	16
	N	-		13	13
O	M5		51.4	51.4	
P	AWG16	AWG14	13	13	
Q	-		61.1	61.1	

## (3) HF Type and FS Type

Model	HF Type [by SOSHIN ELECTRIC CO., LTD.]	FMAC Type [by Schurter, Inc.]
	HF3080C-UQB HF3100C-UQB	FMAC-0934-5010
External Dimensions mm		

## Surge Absorber

### ● Surge Absorber Selection

The surge absorber (for lightning surge) absorbs lightning surge and prevents faulty operation in or damage to electronic circuits.

Main Circuit Power Supply	SERVOPACK Model SGDV-	Recommended Surge Absorber
Single-phase 100 V	□□□F	LT-C12G801WS
Three-phase 200 V	□□□A	LT-C32G801WS
Three-phase 400 V	□□□D	LT-C35G102WS

### ● External Dimensions (Units: mm)

Model: LT-C32G801WS, LT-C35G102WS, LT-C12G801WS [by SOSHIN ELECTRIC CO., LTD.]

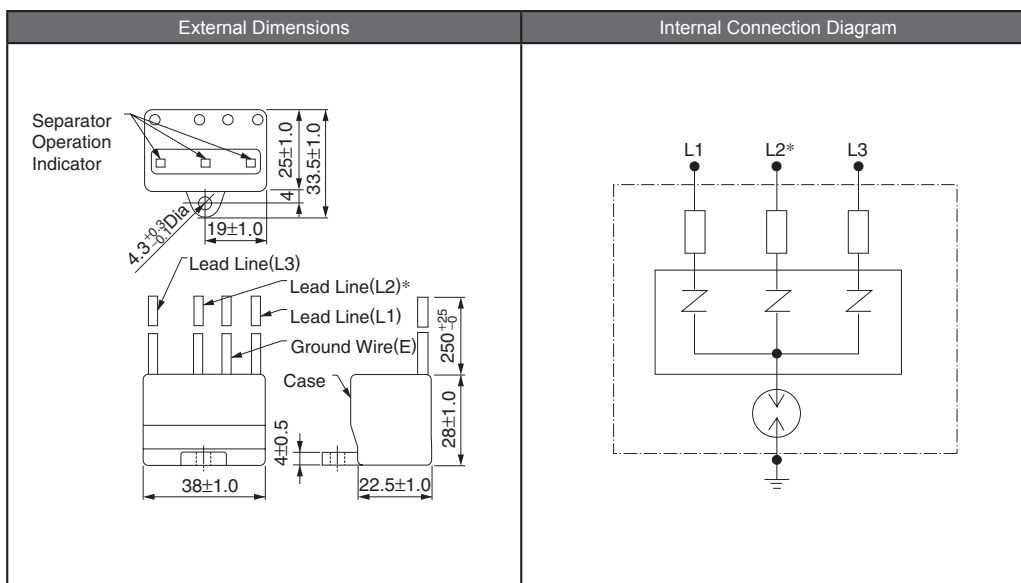

\*: No L2 is on the LT-C12G801WS surge absorber.



# Magnetic Contactors

## ● Magnetic Contactor Selection

A magnetic contactor is required to make the AC power to SERVOPACK ON/OFF sequence externally. Be sure to attach a surge absorber (for switching surge) (surge absorber unit etc.) to the excitation coil of the magnetic contactor.

Main Circuit Power Supply	SERVOPACK Model SGDV-	Magnetic Contactor	
		Model	Specifications
Single-phase 100 V	R70F,R90F,2R1F	SC-03	(RoHS)
	2R8F	SC-4-1	(RoHS)
Three-phase 200 V	R70A,R90A,1R6A,2R8A,3R8A	SC-03	(RoHS)
	5R5A,7R6A,120A	SC-4-1	(RoHS)
	180A,200A	SC-5-1	(RoHS)
	330A, 470A	SC-N1	(RoHS)
	550A	SC-N2	(RoHS)
	590A	SC-N2S	(RoHS)
Three-phase 400 V	780A	SC-N3	(RoHS)
	1R9D,3R5D,5R4D	SC-4-1/G	Coil 24 VDC (RoHS)
	8R4D,120D	SC-5-1/G	Coil 24 VDC (RoHS)
	170D, 260D	SC-N1/G	Coil 24 VDC (RoHS)
	280D, 370D	SC-N2S/G	Coil 24 VDC (RoHS)

Note: Contact Fuji Electric FA Components & Systems Co., Ltd.

## ● External Dimensions (Units: mm)

### · SC-03

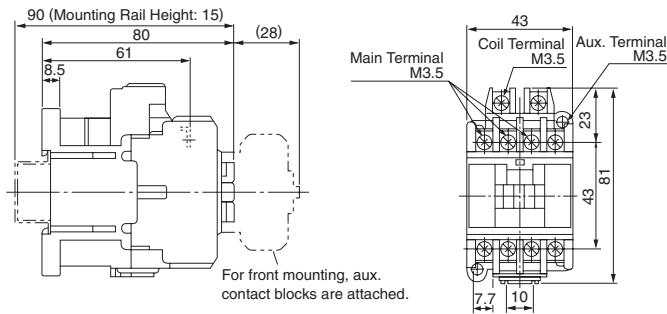

### Mounting Hole Dimensions

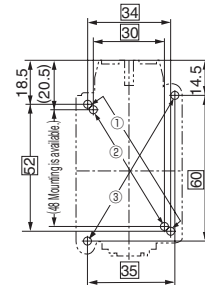

Aux. Contact	Structure
1a	
1b	

● Mounting methods : The following methods ①, ②, ③ are available.

- ① ...34 × (48 to) 52
- ② ...30 × 48
- ③ ...35 × 60

● Mounting screw : 2-M4

Use the two mounting holes on the diagonal line to mount a contactor.

Approx. Mass : 0.32 kg

### · SC-4-1

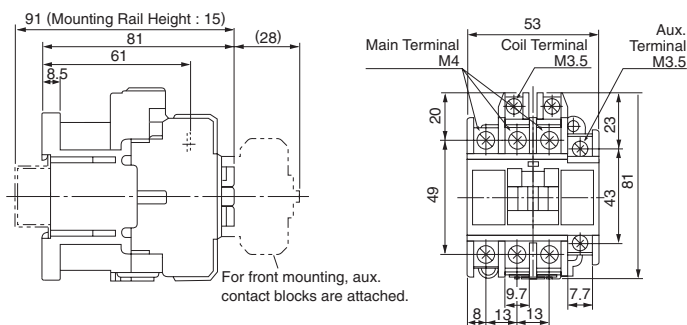

### Mounting Hole Dimensions

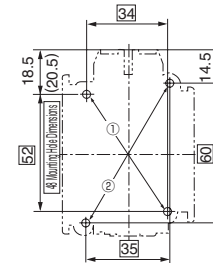

Aux. Contact	Structure
1a	
1b	

● Mounting methods : The following methods ①, w are available.

- ① ...34 × (48 to) 52
- w ...35 × 60

● Mounting screw : 2-M4

Use the two mounting holes on the diagonal line to mount a contactor.

Approx. Mass : 0.36 kg

Magnetic Contactor

· SC-5-1

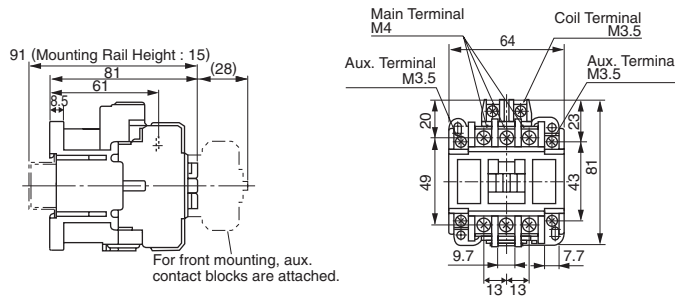

Mounting Hole Dimensions

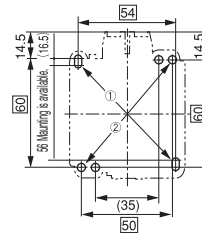

Aux. Contact	Structure
2a	
1a1b	
2b	

• Mounting methods : The following methods ①, ② are available.

①...54 × (56 to) 60

②...50 × 60

• Mounting screw : 2-M4

Use the two mounting holes on the diagonal line to mount a contactor.

Approx. Mass: 0.38 kg

· SC-4-1/G

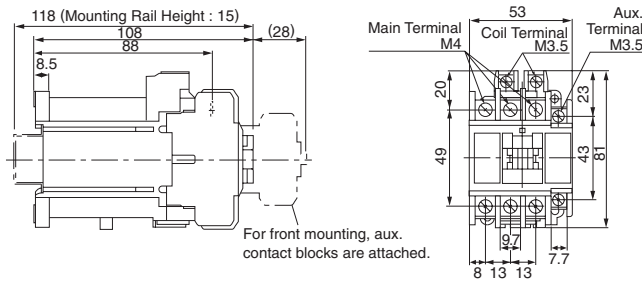

Mounting Hole Dimensions

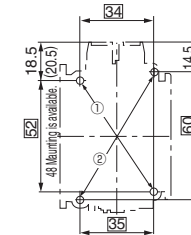

Aux. Contact	Structure
1a	
1b	

• Mounting methods : The following methods ①, ② are available.

①...34 × (48 to) 52

②...35 × 60

• Mounting screw : 2-M4

Use the two mounting holes on the diagonal line to mount a contactor.

Approx. Mass : 0.6 kg

· SC-5-1/G

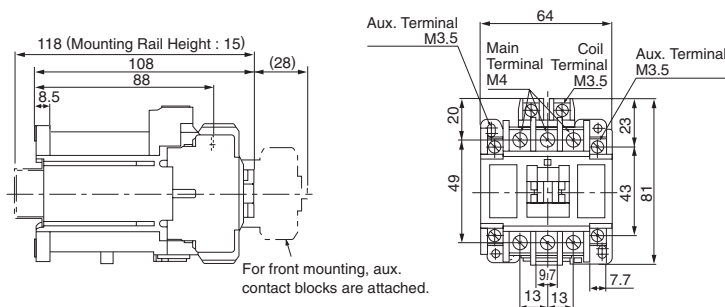

Mounting Hole Dimensions

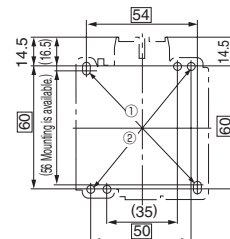

Aux. Contact	Structure
2a	
1a1b	
2b	

• Mounting methods : The following methods ①, ② are available.

①...54 × (56 to) 60

②...50 × 60

• Mounting screw : 2-M4

Use the two mounting holes on the diagonal line to mount a contactor.

Approx. Mass : 0.62 kg

# Magnetic Contactor

## SC-N2S/G

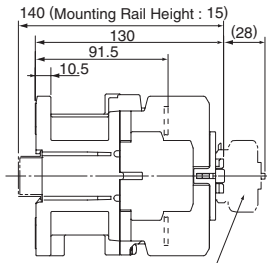

For front mounting, aux. contact blocks are attached.

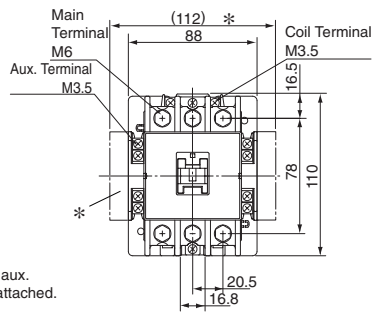

\*: For two side mounting, aux. contact blocks are attached.

### Mounting Hole Dimensions

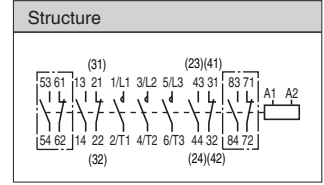
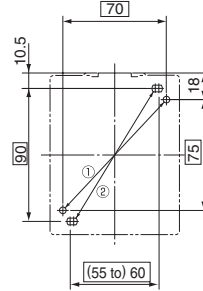

Approx. Mass: 1.4 kg

● Mounting methods : The following methods ①, ② are available.

①...70 × 75 ②... (55 to) 65 × 90

● Mounting screw : 2-M4

Use the two mounting holes on the diagonal line to mount a contactor.

## SC-N1, SC-N2

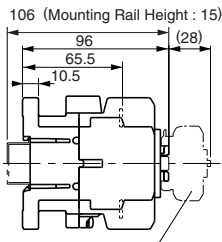

For front mounting, aux. contact blocks are attached.

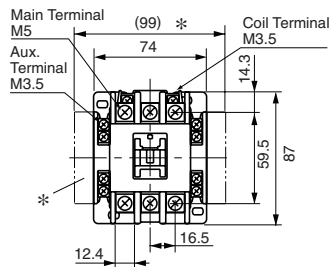

\*: For two side mounting, aux. contact blocks attached.

### Mounting Hole Dimensions

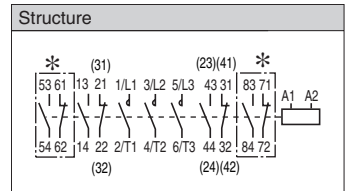
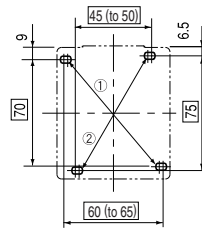

\*: These contacts are used if the auxiliary contacts consist of four normally open (NO) and four normally close (NC) contacts.

Note: The terminals of the auxiliary contacts are numbered differently than conventional terminals. The numbers in parentheses use the conventional method.

Approx. Mass: 0.59 kg

● Mounting methods :

The following methods ①, ② are available.

①...70 × 75 ②... (55 to) 65 × 90

● Mounting screw : 2-M4

Use the two mounting holes on the diagonal line to mount a contactor.

## SC-N2S, SC-N3

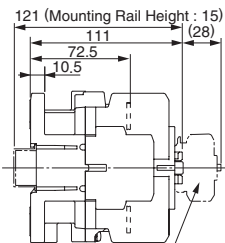

For front mounting, aux. contact blocks are attached.

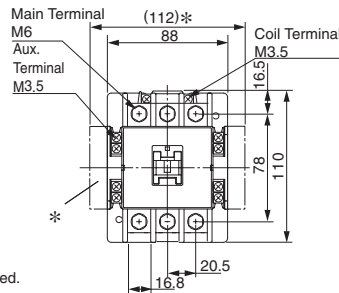

\*: For two side mounting, aux. contact blocks attached.

### Mounting Hole Dimensions

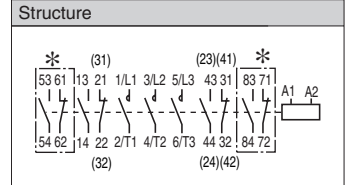
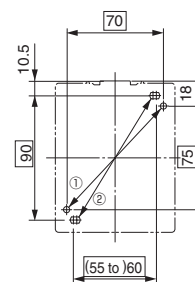

\*: These contacts are used if the auxiliary contacts consist of four normally open (NO) and four normally close (NC) contacts.

Note: The terminals of the auxiliary contacts are numbered differently than conventional terminals. The numbers in parentheses use the conventional method.

Approx. Mass: 1.1 kg

● Mounting methods :

The following methods ①, ② are available.

①...70 × 75 ②... (55 to) 60 × 90

● Mounting screw : 2-M4

Use the two mounting holes on the diagonal line to mount a contactor.

## SC-N1/G

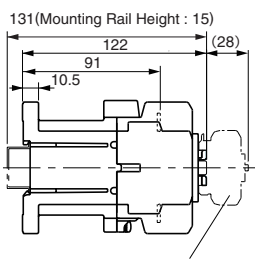

For front mounting, aux. contact blocks are attached.

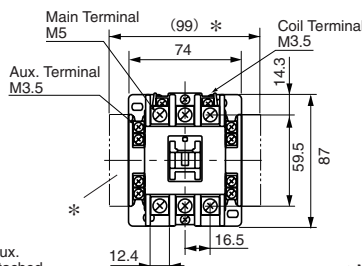

\*: For two side mounting, aux. contact blocks attached.

### Mounting Hole Dimensions

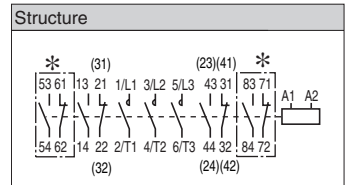
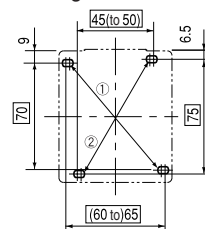

\*: These contacts are used if the auxiliary contacts consist of four normally open (NO) and four normally close (NC) contacts.

Note: The terminals of the auxiliary contacts are numbered differently than conventional terminals. The numbers in parentheses use the conventional method.

Approx. Mass: 0.82 kg

● Mounting methods :

The following methods ①, ② are available

①... (60 to) 65 × 70 ②... 45 (to 50) × 70

● Mounting screw : 2-M4

Use the two mounting holes on the diagonal line to mount a contactor.

## AC/DC Reactors

## ● Selection

If power supply harmonic suppression is needed, connect a DC reactor between the three-phase 200 V or three-phase 400 V SERVOPACK main circuit terminals ⊖1 and ⊖2. Also, connect an AC reactor to single-phase 100 V SERVOPACK main circuit terminal L1 in series.

Select AD/DC reactors according to the SERVOPACK ratings.

Main Circuit Power Supply	SERVOPACK SGD V-	AC/DC Reactor Model	Inductance mH	Rated Current A
Single-phase 100 V	R70F	X5053	20.0	2.0
	R90F			
	2R1F	X5054	5.0	3.0
	2R8F	X5056	2.0	5.0
Three-phase 200 V	R70A	X5061	2.0	4.8
	R90A			
	1R6A			
	2R8A			
	3R8A			
	5R5A			
	7R6A			
	120A	X5060	1.5	8.8
	180A			
	200A	X5059	1.0	14.0
	330A	X5068	0.47	26.8
	470A	-	-	-
550A				
590A				
780A				
Three-phase 400 V	1R9D	X5074	4.7	1.5
	3R5D	X5075	3.3	4.5
	5R4D			
	8R4D	X5076	2.2	8.6
	120D			
	170D	X5077	1.5	14.1
	210D	-	-	-
	260D			
	280D			
370D				

Note: RoHS-compliant models are not available. The last digit of an RoHS-compliant model number is R. Contact the manufacturers when selecting an RoHS-compliant model.

## ● External Dimensions (Units: mm)

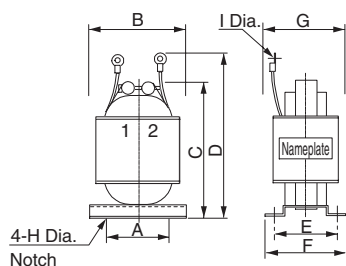

AC/DC Reactor Model	External Dimensions									Approx. Mass kg
	A	B	C	D	E	F	G	H Dia.	I Dia.	
X5053	35	52	90	105	35	45	50	4	4.3	0.6
X5054	35	52	80	95	30	40	45	4	4.5	0.4
X5056	35	52	80	95	30	40	45	4	4.3	0.4
X5059	50	74	125	140	35	45	60	5	5.3	1.1
X5060	40	59	105	140	35	45	60	5	5.3	1.1
X5061	35	52	80	95	35	45	50	4	4.3	0.5
X5068	50	74	125	155	53	66	75	5	6.4	1.9
X5074	30	47	70	85	28	38	45	4	4.3	0.3
X5075	40	59	100	120	40	50	55	4	4.3	0.9
X5076	50	74	125	140	35	45	60	5	4.3	1.1
X5077	50	74	125	155	53	66	75	5	5.3	1.9

# Holding Brake Power Supply Unit

## ● Holding Brake Power Supply Unit

### IMPORTANT

- We recommend opening or closing the circuit for the holding brake's power supply so that switching will occur on the DC side of the holding brake power supply unit. This will reduce brake operation time compared to switching on the AC side.
- When switching on the DC side, install an extra surge absorber (for lightning surge) apart from the surge absorber (for lightning surge) built in the brake circuit near the brake coil, in order to prevent damage to the brake coil from surge voltage.
- Holding brake power supply units for 24 VDC are not provided by Yaskawa. Please obtain these from other manufacturers. Do not connect holding brake power supply units for different output voltages to SERVOPACKs. Overcurrent may result in burning.

### ● Model

200 V input: LPSE-2H01-E  
100 V input: LPDE-1H01-E

### ● Specifications

Rated output voltage: 90 VDC  
Maximum output current: DC 1.0 A  
Lead wire length: 500 mm each  
Maximum ambient temperature: 60°C  
Lead wires: Color coded (refer to the table below)

AC input		Brake end
100 V	200 V	
Blue/white	Yellow/white	Red/black

### ● External Dimensions (Units: mm)

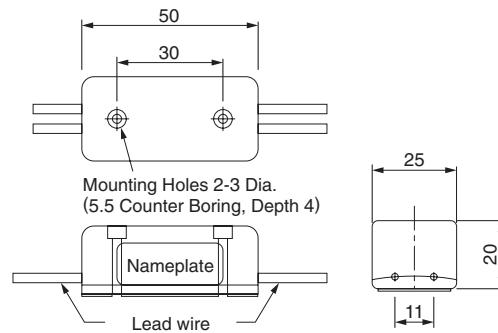

### ● Internal Circuits

We recommend opening or closing the circuit for the holding brake's power supply so that switching will occur on the DC side of the holding brake power supply unit. This will reduce brake operation time compared to switching on the AC side. When switching on the DC side, install an extra surge absorber apart from the surge absorber built in the brake circuit near the brake coil, in order to prevent damage to the brake coil from surge voltage.

#### Brake Power Supply for 200 VAC

Internal Circuit for Model: LPSE-2H01-E

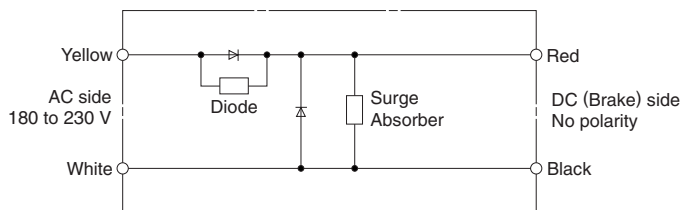

#### Brake Power Supply for 100 VAC

Internal Circuit for Model: LPDE-1H01-E

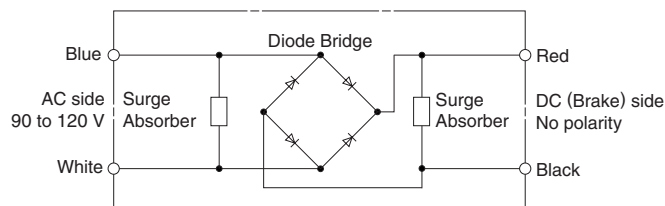

## Regenerative Resistors

### ● Regenerative Power and Regenerative Resistance

The rotational energy of driven machine such as servomotor is returned to the SERVOPACK. This is called regenerative power. The regenerative power is absorbed by charging the smoothing capacitor, but when the chargeable energy is exceeded, the regenerative power is further consumed by the regenerative resistor.

The servomotor is driven in regeneration state in the following circumstances:

- While decelerating to a stop during acceleration and deceleration operation.
- Continuous operation on the vertical axis.
- During continuous operation with the servomotor rotated from the load side (negative load).

A servomotor may not be operated with an overhanging load, which tends to continuously rotate the motor. following figures show a typical example of such a load.

● DO NOT use the servomotor with the Vertical Axis Motor Drive without Counterweight

● DO NOT use the servomotor with the Feeding Motor Drive

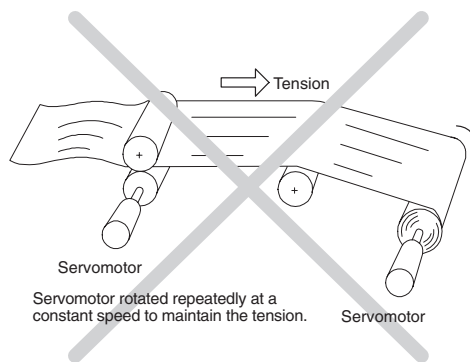
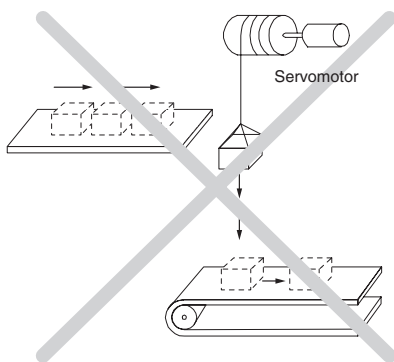

### IMPORTANT

- Never operate servomotors with an overhanging load. Doing so will cause the SERVOPACKs' regenerative brake to be applied continuously and the regenerative energy of the load may exceed the allowable range causing damage to the SERVOPACK.
- The regenerative brake capacity of the SGD V SERVOPACKs is rated for short-term operation approximately equivalent to the time it takes to decelerate to a stop.

External regenerative resistors are sometimes required by the AC servo drive capacity selection program SigmaJunmaSize+. When using an external regenerative resistor, parameter Pn600 must be set.

For details, refer to 3.6.2 Setting Regenerative Resistor Capacity on “ $\Sigma$ -V Series User's Manual Design and Maintenance.” (manual no. SIEP S800000 45)

### ● Regenerative Resistor Selection

Select regenerative resistors in the following manner. External resistors are to be provided by users.

Voltage	SERVOPACK Model SGD V-	Built-in Regenerative Resistor	Necessity of External Regenerative Resistors	Necessity of External Regenerative Resistors
Single-phase 100 V	□□□F	None	Basically Not Required	No built-in regenerative resistor is provided, however, normally an external regenerative resistor is not required. Install external regenerative resistors when the smoothing capacitor in SERVOPACK cannot process all the regenerative power.
Three-phase 200 V	R70A, R90A, 1R6A, 2R8A	Standard Equipment <sup>*1</sup>	Basically Not Required	A built-in regenerative resistor is provided as standard. Install external regenerative resistors when the built-in regenerative resistor cannot process all the regenerative power.
	3R8A, 5R5A, 7R6A 120A, 180A, 200A, 330A			
Three-phase 400 V	470A, 550A 590A, 780A	None	Required <sup>*2</sup>	No built-in regenerative resistor is provided, so the external regenerative resistor is required. If the external resistor is not connected with the SERVOPACK, the alarm 300 is detected as a regeneration error alarm.
	1R9D, 3R5D, 5R4D 8R4D, 120D, 170D	Standard Equipment <sup>*1</sup>	Basically Not Required	A built-in regenerative resistor is provided as standard. Install external regenerative resistors when the built-in regenerative resistor cannot process all the regenerative power.
Three-phase 400 V	210D, 260D, 280D, 370D	None	Required <sup>*2</sup>	No built-in regenerative resistor is provided, so the external regenerative resistor is required. If the external resistor is not connected with the SERVOPACK, the alarm 300 is detected as a regeneration error alarm.

\*1: For specifications of built-in regenerative resistors, refer to the next page.

\*2: Regenerative resistor units are available.

# Regenerative Resistors

## ● Specifications of Built-in Regenerative Resistor

The following table shows the specifications of the SERVOPACK's built-in resistor and the amount of regenerative power (average values) that it can process.

Applicable SERVOPACK SGDV-	Specifications of Built-in Resistor		Regenerative Power Processed by Built-in Resistor <sup>1</sup> W	Minimum Allowable Resistance Ω	
	Resistance Ω	Capacity W			
Single-phase 100 V	□□□F	-	-	40	
Three-phase 200 V	R70A, R90A, 1R6A, 2R8A	-	-	40	
	3R8A, 5R5A, 7R6A	50	40	8	
	120A	20	50	10	
	180A, 200A	12	80	16	
	330A	8	180	36	
	470A	(6.25) <sup>2</sup>	(880) <sup>2</sup>	(180) <sup>2</sup>	5.8
	550A, 590A, 780A	(3.13) <sup>3</sup>	(1760) <sup>3</sup>	(350) <sup>3</sup>	2.9
Three-phase 400 V	1R9D, 3R5D, 5R4D	108	70	14	
	8R4D, 120D	45	140	28	
	170D	32	180	36	
	210D, 260D	(18) <sup>4</sup>	(880) <sup>4</sup>	(180) <sup>4</sup>	18
	280D, 370D	(14.25) <sup>5</sup>	(1760) <sup>5</sup>	(350) <sup>5</sup>	14.25

\*1: The average regenerative power that can be handled is 20% of the rated capacity of the regenerative resistor built into the SERVOPACK.

\*2: For the optional JUSP-RA04-E regenerative resistor unit.

\*3: For the optional JUSP-RA05-E regenerative resistor unit.

\*4: For the optional JUSP-RA18-E regenerative resistor unit.

\*5: For the optional JUSP-RA19-E regenerative resistor unit.

## ● References for External Resistor (by Iwaki Musen Kenkyusho Co., Ltd.)

Model	Specifications
RH120	70 W, 1 to 100 Ω
RH150	90 W, 1 to 100 Ω
RH220□	120 W, 1 to 100 Ω
RH300C	200 W, 1 to 10 kΩ
RH500	300 W, 1 to 30 Ω

Notes: 1 Contact the manufacturers when in need of an RoHS-compliant model.  
2 When using an external regenerative resistor, parameter Pn600 must be set.  
For details, refer to 3.6.2 Setting Regenerative Resistor Capacity on "J-V Series User's Manual Design and Maintenance." (manual no. SIEP S800000 45)

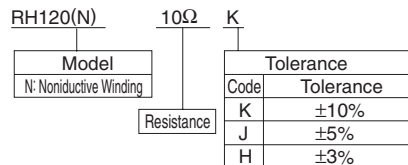

## ● Specifications

Resistance Tolerance	K : ±10% J : ±5% H : ±3%
Temperature Resistance Characteristics	±400PPM / °C (20 Ω max.), ±260PPM / °C (20 Ω min.)
Withstand Voltage	2000 VAC / min. ΔR: ± (0.1%+0.05 Ω)
Insulation Resistance	500 VDC, 20 MΩ min.
Short-time Overload	When 10 times of rated power is applied for five seconds, ΔR: ± (2%+0.05 Ω)
Life	1000 hours of repeating the operation ON for 90 minutes and OFF for 30 minutes, ΔR: ± (5%+0.05 Ω)
Heat Resistance	Not ignite after having applied 10 times of rated power for one minute
Operating temperature	-25°C to +150°C

## ● External Dimensions (Units: mm)

RH120, 150, 220	RH220B																																												
<table border="1"> <thead> <tr> <th>Model</th> <th>Rated Power</th> <th>Resistance</th> </tr> </thead> <tbody> <tr> <td>RH120</td> <td>70 W</td> <td>1Ω to 100Ω</td> </tr> <tr> <td>RH150</td> <td>90 W</td> <td>1Ω to 100Ω</td> </tr> <tr> <td>RH220</td> <td>120 W</td> <td>1Ω to 100Ω</td> </tr> </tbody> </table> <table border="1"> <thead> <tr> <th>Dimensions</th> <th>A</th> <th>B</th> <th>C</th> <th>D</th> <th>E</th> <th>F</th> <th>G</th> </tr> </thead> <tbody> <tr> <td>RH120</td> <td>182</td> <td>150</td> <td>172</td> <td>16</td> <td>42</td> <td>22</td> <td>20</td> </tr> <tr> <td>RH150</td> <td>212</td> <td>180</td> <td>202</td> <td>16</td> <td>44</td> <td>24</td> <td>30</td> </tr> <tr> <td>RH220</td> <td>230</td> <td>200</td> <td>220</td> <td>15</td> <td>60</td> <td>24</td> <td>20</td> </tr> </tbody> </table>	Model	Rated Power	Resistance	RH120	70 W	1Ω to 100Ω	RH150	90 W	1Ω to 100Ω	RH220	120 W	1Ω to 100Ω	Dimensions	A	B	C	D	E	F	G	RH120	182	150	172	16	42	22	20	RH150	212	180	202	16	44	24	30	RH220	230	200	220	15	60	24	20	<p>Lead wire length : L = 500 Rated power : 120 W Resistance : 1 Ω to 100 Ω</p>
Model	Rated Power	Resistance																																											
RH120	70 W	1Ω to 100Ω																																											
RH150	90 W	1Ω to 100Ω																																											
RH220	120 W	1Ω to 100Ω																																											
Dimensions	A	B	C	D	E	F	G																																						
RH120	182	150	172	16	42	22	20																																						
RH150	212	180	202	16	44	24	30																																						
RH220	230	200	220	15	60	24	20																																						
<p>Lead wire length : L = 300 Rated power : 200 W Resistance : 1 Ω to 10 kΩ</p>	<p>Lead wire length : L = 450 Rated power : 300 W Resistance : 1 Ω to 30 Ω</p>																																												

## External Regenerative Resistor

### ● Regenerative Resistor Unit

SERVOPACK Model SGD V-	Regenerative Resistor Unit Model	Specifications	Allowable Power Loss
470A	JUSP-RA04-E	6.25 $\Omega$ , 880 W	180 W
550A, 590A, 780A	JUSP-RA05-E	3.13 $\Omega$ , 1760 W	350 W
210D, 260D	JUSP-RA18-E	18 $\Omega$ , 880 W	180 W
280D, 370D	JUSP-RA19-E	14.25 $\Omega$ , 1760 W	350 W

Note: Only when using the regenerative resistors above, parameter Pn600 does not need to be set.

### ● External Dimensions

#### (1) JUSP-RA04-E, -RA05-E

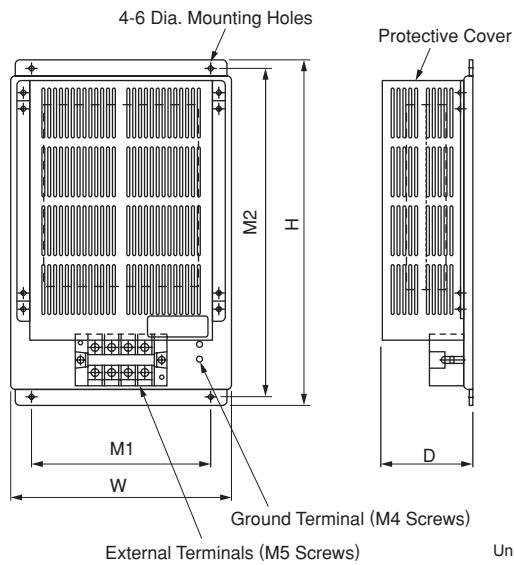

Units: mm

Model	W	H	D	M1	M2	Approx. Mass
JUSP-RA04-E	220	350	92	180	335	4 kg
JUSP-RA05-E	300	350	95	250	335	7 kg

#### (2) JUSP-RA18-E

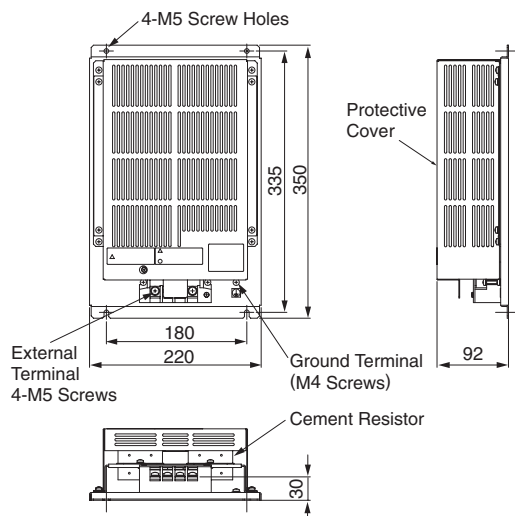

#### (3) JUSP-RA19-E

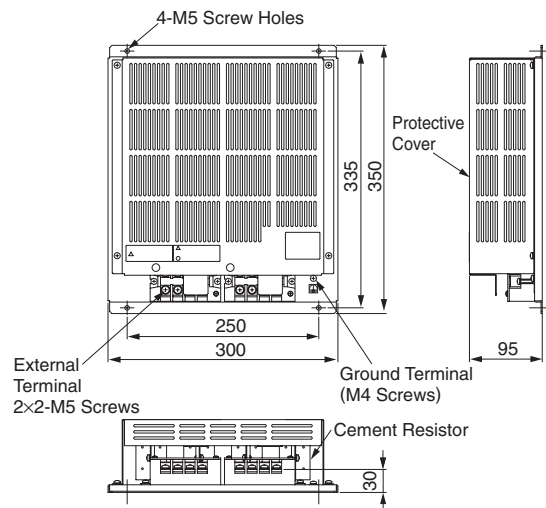



# Analog Voltage Reference SERVOPACKs Pulse Train Reference SERVOPACKs

## SGDV-□□□ES1

(Analog Voltage Reference)

## SGDV-□□□EP1

(Pulse Train Reference)



### Model Designations

S G D V - 2R9 E S1 A 002 00 0

Σ-V Series  
SGDV  
SERVOPACKs  
with DC Power Input

1st+2nd+3rd digits

4th digit

5th+6th digits

7th digit

8th+9th+10th digits

11th+12th digits

13th digit

1st+2nd+3rd digits Current

Voltage	Code	Applicable Servomotor Max. Capacity kW
24 VDC/	1R7	0.011
48 VDC	2R9	0.030

4th digit Power Supply Voltage

Code	Specifications
E	48 VDC*

5th+6th digits Interface

Code	Specifications
S1	Analog Voltage Reference (For Rotary Servomotors)
P1	Pulse Train Reference (For Rotary Servomotors)

7th digit Design Revision Order

A, B...

8th+9th+10th digits Options (hardware)

Code	Specifications
002	Base-mounted, varnish(standard)

11th+12th digits Options (software)

Code	Specifications
00	Standard

13th digit Options (parameter)

Code	Specifications
0	Standard

\*: Either a 24-VDC or a 48-VDC power supply can be used for the main circuit. The control power supply must be 24 VDC.  
Note: If the option codes digits 8 to 13 are all zeros, they are omitted.

# Features

## ● Compact design

With compact SERVOPACKs using less space, you can make effective use of limited space and make controller panels and systems smaller.

## ● Applications with DC power

These compact, high-performance SERVOPACKs can be powered by batteries so they can improve the performance of battery-operated equipment for handling & transfer systems, such as robots used in clean rooms and automated guided vehicles (AGVs).

Two different power supplies provide power for the control circuit and for the main circuit. Troubleshooting can be performed by shutting off the power to the main circuit if any alarm occurs.

Either a 24-VDC or 48-VDC power supply can be used for the main circuit. Use of a 48-VDC power supply can improve the torque-motor speed characteristics (For the control circuit, only a 24-VDC power supply can be used). Degree to which the characteristics can be improved depends on which motor is used.

## ● Improved usability with state-of-the-art technology

New advanced autotuning lets you adjust your system quickly for best performance. A wide variety of functions are provided: the model follow-up control function that reduces positioning time, the vibration suppression function that suppresses vibration of machines, friction compensation function that can exert its ability in applications with load fluctuations, and the new tuning-less function most suitable for systems that require a long startup time or that involve a large load fluctuation.

# Ratings

SERVOPACK Model SGD□-□□□□		1R7E		2R9E	
Applicable Servomotor Max. Capacity	kW	0.011		0.030	
Continuous Output Current	Arms	1.7		2.9	
Max. Output Current	Arms	4.1		8.6	
Regenerative Resistors		None			
Main Circuit*		24 VDC±15%	48 VDC±15%	24 VDC±15%	48 VDC±15%
Control Circuit		24 VDC±15%			

\*: Either a 24-VDC or a 48-VDC power supply can be used for the main circuit. When a 24-VDC power supply is used, the torque-motor speed characteristics for a 48 VDC cannot be achieved.

## ● SERVOPACK Overload Characteristics

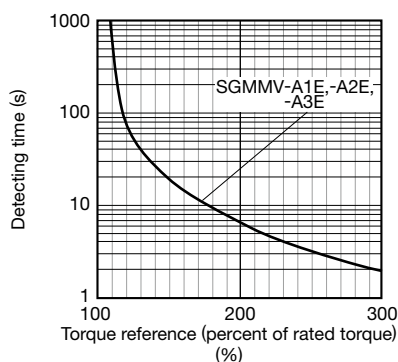
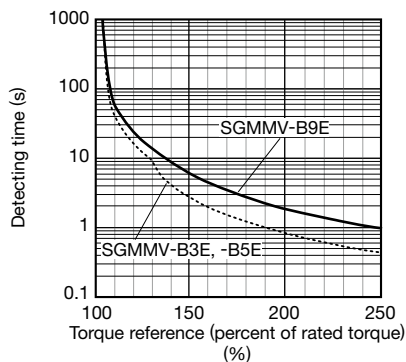

Note: Overload characteristics shown above do not guarantee continuous duty of 100% or more output. Use a servomotor with effective torque within the continuous duty zone of Torque-Motor Speed Characteristics.

DC

Analog/Pulse Type SERVOPACKs

# Specifications

Items		Specifications	
Control Method		PWM control, sine-wave driven	
Feedback		Serial encoder: 17-bit (incremental/absolute)	
Operating Conditions	Ambient Temperature	0 to +55°C	
	Storage Temperature	-20 to +85°C	
	Ambient Humidity	90%RH or less	With no freezing or condensation
	Storage Humidity	90%RH or less	
	Vibration Resistance	4.9 m/s <sup>2</sup>	
	Shock Resistance	19.6 m/s <sup>2</sup>	
	Protection Class	IP10	An environment that satisfies the following conditions. <ul style="list-style-type: none"> <li>• Free of corrosive or flammable gases</li> <li>• Free of exposure to water, oil, or chemicals</li> <li>• Free of dust, salts, or iron dust</li> </ul>
	Pollution Degree	2	
	Altitude	1000 m or less	
Others	Do not use SERVOPACKs in the following locations: <input type="checkbox"/> Locations subject to static electricity noise, strong electromagnetic/magnetic fields, radioactivity		
Applicable Standards		UL508C EN55011/A1, EN61000-6-2, EN61800-3, EN61800-5-1	
Mounting		Base-mounted	
Performance	Speed Control Range	1:5000 (The lower limit of the speed control range must be lower than the point at which the rated torque does not cause the servomotor to stop.)	
	Speed Regulation <sup>*1</sup>	Load Fluctuation	0% to 100% load: ±0.01% max. (at rated speed)
		Voltage Fluctuation	Rated voltage: ±10% : 0% (at rated speed)
		Temperature Fluctuation	25±25°C : ±0.1% max. (at rated speed)
	Torque Control Tolerance (Repeatability)	±1%	
Soft Start Time Setting	0 to 10 s (can be set individually for acceleration and deceleration.)		
I/O Signal	Encoder Output Pulses	Phase A, phase B, phase C: line driver output The number of dividing pulse: Any setting ratio is available. <sup>*2</sup>	
	Sequence Input	Number of Channels	7 channels
		Functions	<ul style="list-style-type: none"> <li>• Servo ON (/S-ON)</li> <li>• Control selection(/C-SEL)</li> <li>• Proportional control (/P-CON)</li> <li>• SEN signal (/SEN)</li> <li>• Forward run prohibited (P-OT), reverse run prohibited (N-OT)</li> <li>• Zero clamping (/ZCLAMP)</li> <li>• Reference pulse inhibit (/INHIBIT)</li> <li>• Alarm reset (/ALM-RST)</li> <li>• Gain selection (/G-SEL)</li> <li>• Forward external torque limit (/P-CL), reverse external torque limit (/N-CL)</li> <li>• Reference pulse input multiplication switching (/PSEL)</li> <li>• Internal set speed selection (/SPD-D, /SPD-A, /SPD-B)</li> <li>• Positive and negative logic can be changed.</li> </ul>
	Sequence Output	Fixed Output	Servo alarm (ALM)
Output Signals which can be allocated		Number of Channels	3 channels
		Functions	<ul style="list-style-type: none"> <li>• Positioning completion (/COIN)</li> <li>• Brake (/BK)</li> <li>• Speed coincidence detection (/V-CMP)</li> <li>• Warning (/WARN)</li> <li>• Rotation detection (/TGON)</li> <li>• Near (/NEAR)</li> <li>• Servo ready (/S-RDY)</li> <li>• Reference pulse input multiplication switching output (/PSELA)</li> <li>• Torque limit detection (/CLT)</li> <li>• Speed limit detection (/VLT)</li> <li>• Positive and negative logic can be changed.</li> </ul>

\*1: Speed regulation is defined as follows:

$$\text{Speed regulation} = \frac{\text{No-load motor speed} - \text{Total load motor speed}}{\text{Rated motor speed}} \times 100\%$$

The motor speed may change due to voltage fluctuation or temperature fluctuation.

The ratio of speed changes to the rated speed represent speed regulation due to voltage and temperature fluctuations.

\*2: For details, refer to 5.3.7 Setting Encoder Output Pulse in the AC Servo Drives DC Power Input  $\Sigma$ -V Series USER'S MANUAL Design and Maintenance

(Cont'd)

## Specifications

Items		Specifications			
Communications	Digital Operator	Compatible with the digital operator for $\Sigma$ -V SERVOPACKs (Model: JUSP-OP05A-1-E). The digital operator must be connected with the SERVOPACK via the analog monitor unit (Model: JUSP-PC001-E) or the digital operator's relay cable (Model: JZSP-CF1S00-A3-E).			
	Computer (USB)	Compatible with SigmaWin+. Compliant with the USB1.1 standard (12 Mbps)			
Display		Servo alarm (ALM): red; servo ready (RDY): green			
Analog Monitor		Number of points: 2 Output voltage: $\pm 10$ VDC (linearity effective range: $\pm 8$ V) Output through the analog monitor unit (model: JUSP-PC001-E)			
Dynamic Brake (DB)		Not available			
Regenerative Processing		Not available			
Overtravelling (OT) Prevention		Decelerate to a stop or coast to a stop when overtraveling is detected and an overtravel signal (P-OT or N-OT) is input.			
Protective Functions		Overcurrent, Overvoltage, low voltage, overload, etc.			
Utility Functions		Gain adjustment, alarm history, JOG operation, origin search, etc.			
Analog Voltage Reference	Speed Control	Soft Start Time Setting		0 to 10 s (can be set individually for acceleration and deceleration.)	
		Input Signals	Reference Voltage	Max. input voltage: $\pm 12$ V (forward speed reference with positive reference) Factory setting: 6 VDC at rated speed (Input gain setting can be changed.)	
			Input Impedance	About 14 k $\Omega$	
	Circuit Time Constant		30 $\mu$ s		
	Internal Set Speed Control	Rotation Direction Selection	With P control signal		
		Speed Selection	With forward/reverse external torque limit signal (speed 1 to 3 selection). Servomotor stops or another control method is used when both are OFF.		
	Torque Control	Input Signals	Reference Voltage	Max. input voltage: $\pm 12$ V (forward torque reference with positive reference) Factory setting: 3 VDC at rated torque (Input gain setting can be changed.)	
			Input Impedance	About 14 k $\Omega$	
			Circuit Time Constant	16 $\mu$ s	
	Pulse Train Reference	Feedforward Compensation		0 to 100%	
Positioning Completed Width Setting		0 to 1073741824 reference units			
Position Control		Input Signals	Reference Pulse	Type	Select one of them: Sign + pulse train, CW + CCW pulse train, or two-phase pulse train with 90° phase differential
				Form	For line driver, open collector
			Max. Input Pulse Frequency*	Line driver	Sign + pulse train, CW + CCW pulse train: 4 Mpps Two-phase pulse train with 90° phase differential: 1 Mpps
				Open Collector	Sign + pulse train, CW + CCW pulse train: 200 kpps Two-phase pulse train with 90° phase differential: 200 kpps
Reference pulse input multiplication switching		1 to 100 times			
Clear Signal		Position error clear For line driver, open collector			

\*: If the maximum reference frequency exceeds 1 Mpps, use a shielded cable for I/O signals and ground both ends of the shield.  
Connect the shield at the SERVOPACK to the connector shell.

DC

Analog/Pulse Type SERVOPACKs

## Power Supply Capacities and Power Losses

The following table shows SERVOPACK's power supply capacities and power losses at the rated output.

Main Circuit Power Supply	Applicable Servomotor Max. Capacity W	SERVOPACK Model SGDV-	Main Circuit Power Supply Capacity per SERVOPACK W	Output Current Arms	Main Circuit Power Loss W	Regenerative Resistor Power Loss W	Control Circuit Power Loss W	Total Power Loss W
24 VDC	11	1R7E	108	1.7	3.4	-	7.2	10.6
	30	2R9E	165	2.9	6.9			14.1
48 VDC	11	1R7E	169	1.7	3.4	-	7.2	10.6
	30	2R9E	411	2.9	6.9			14.1

Note: These power supply capacities are net values at instantaneous maximum loads.

## Selecting Cables

- Cables for **CN1** **CN3** **CN5** **CN7** (Analog Voltage Reference/Pulse Train Reference SERVOPACKs)

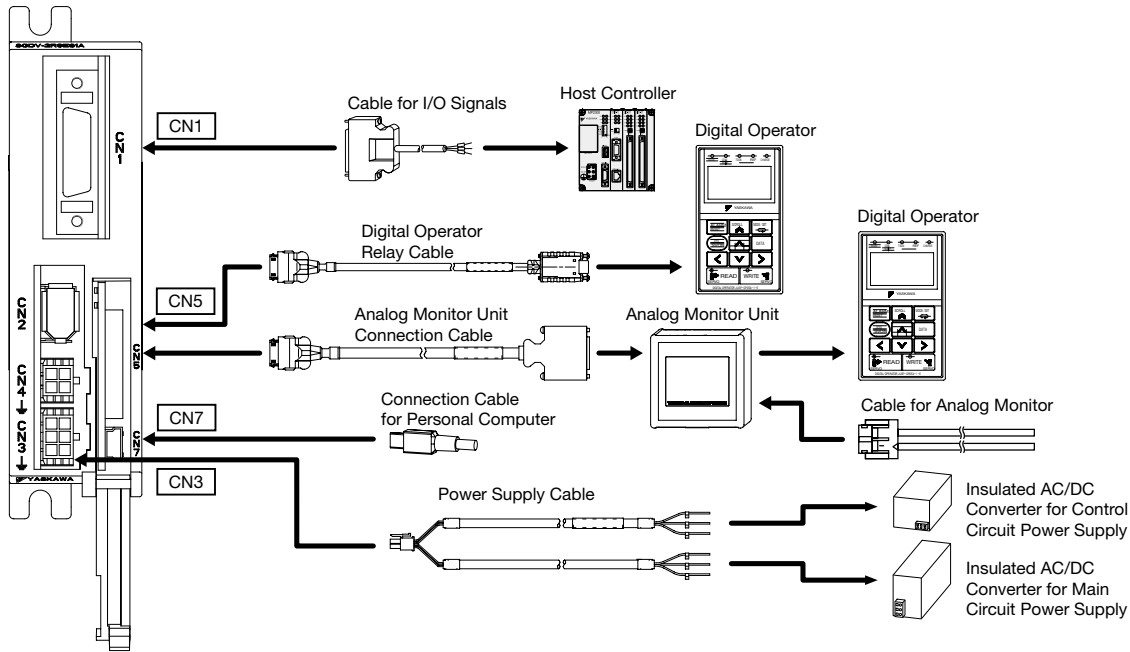

Name	Length	Order No.	Specifications	Details	
<b>CN1</b> Cables for I/O Signals	Connector Kit	JZSP-CS19-2-E	Soldered	(1)	
	Connector Terminal Converter Unit	0.5 m	SBK-U-VBA-A5	Terminal Block and Connection Cable	(2)
		1 m	SBK-U-VBA-01		
		3 m	SBK-U-VBA-03		
Cable with Loose wire at One End	1 m	JZSP-CSI02-1-E		(3)	
	2 m	JZSP-CSI02-2-E			
	3 m	JZSP-CSI02-3-E			
<b>CN3</b> Power Supply Cables	Cable with Loose wire at One End	1 m	JZSP-CF1G00-01-E	SERVOPACK End      Power Supply End	(4)
		2 m	JZSP-CF1G00-02-E		
		3 m	JZSP-CF1G00-03-E		
		4 m	JZSP-CF1G00-04-E		
		5 m	JZSP-CF1G00-05-E		
		6 m	JZSP-CF1G00-06-E		
		7 m	JZSP-CF1G00-07-E		
		8 m	JZSP-CF1G00-08-E		
		9 m	JZSP-CF1G00-09-E		
		10 m	JZSP-CF1G00-10-E		
<b>CN5</b> Cables for Digital Operator/Analog Monitor Unit	Digital Operator	JZSP-OP05A-1-E	With Connection Cable (1 m)	(5)	
	Digital Operator Relay Cable	0.3 m	JZSP-CF1S00-A3-E	SERVOPACK End      Digital Operator End	(6)
	Analog Monitor Unit		JZSP-PC001-E		(7)
	Analog Monitor Unit Connection Cable	0.3 m	JZSP-CF1S05-A3-E	SERVOPACK End      Analog Monitor Unit End	(8)
	Cables for Analog Monitor	1 m	JZSP-CA01-E	Analog Monitor Unit End	(9)
<b>CN7</b> Connection Cables for Personal Computer	2.5 m	JZSP-CVS06-02-E	Cable with Connectors at Both Ends	(10)	

DC

Analog/Pulse Type SERVOPACKs

# Selecting Cables

## (1) Connector Kit for CN1

Use the following connector and cable to assemble the cable. The CN1 connector kit includes one case and one connector.

Connector Kit Model	Case		Connector	
	Model	Qty	Model	Qty
JZSP-CSI9-2-E	10326-52A0-008*	1 set	10126-3000PE* (Soldered)	1

\* : Manufactured by Sumitomo 3M Ltd.

### • Cable Size

Item	Specifications
Cable	Use twisted-pair or twisted-pair shielded wire.
Applicable Wires	AWG24,26,28,30
Cable Finished Diameter	16 dia. max.

### □ External Dimensions of Case (Units: mm)

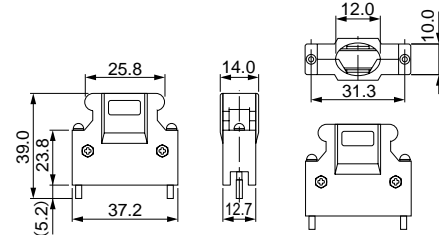

### □ External Dimensions of Connector (Units: mm)

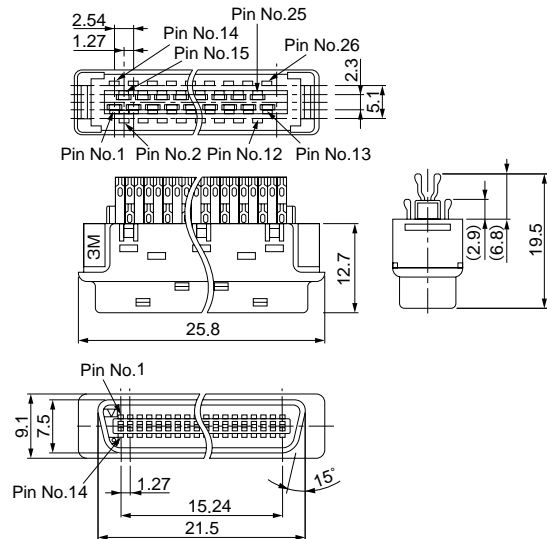

## (2) Connector Terminal Converter Unit for CN1

### • Configurations

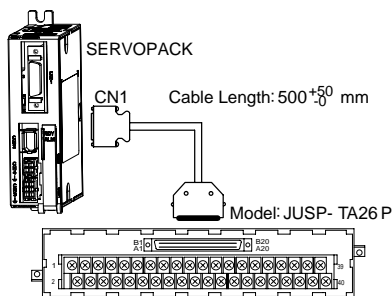

### • External Dimensions of Terminal Block (Units: mm)

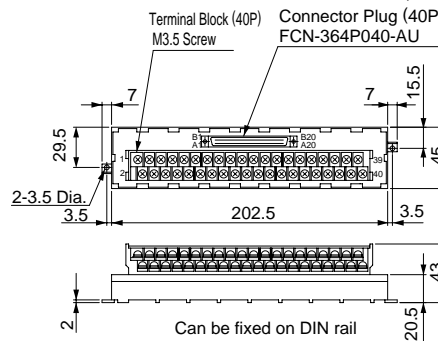

### • External Dimensions of Cable (Units: mm)

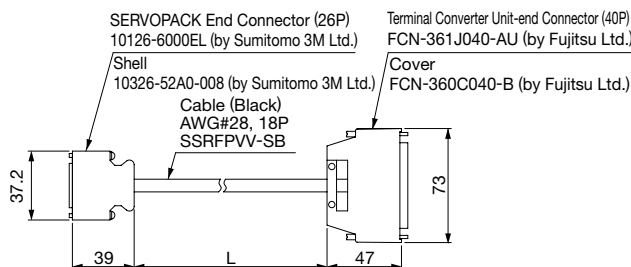

Model	Cable Length (L)	Approx. Mass
JUSP-TA26P-E	0.5 m	100 g
JUSP-TA26P-1-E	1 m	200 g
JUSP-TA26P-2-E	2 m	400 g

Note: The pin number in the SERVOPACK connector and the pin number in the terminal block are the same. Pin numbers 1 to 26 are used in the terminal block. Do not use a pin number of 27 or higher.

If assembling cables, refer to ●Cable with Loose Wires at One End for CN1 Connection Diagram of JZSP-CSI02-□-E Cable on the next page.

## Selecting Cables

- (3) Cable with Loose Wires at One End for CN1  
 • External Dimensions (Units: mm)

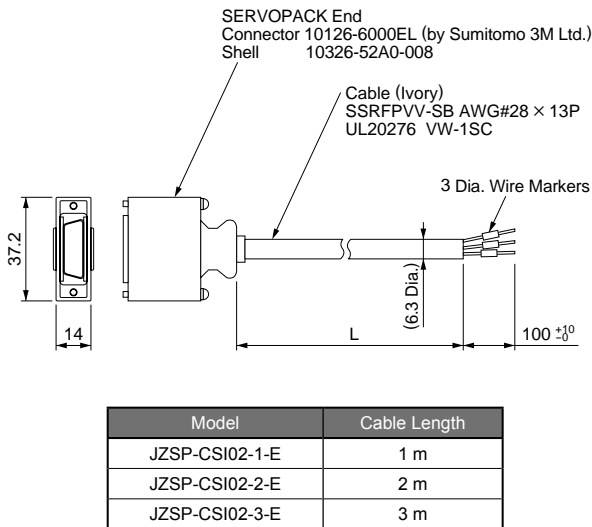

- Cable with Loose Wires at One End for CN1  
 Connection Diagram of JZSP-CSI02-□-E Cable

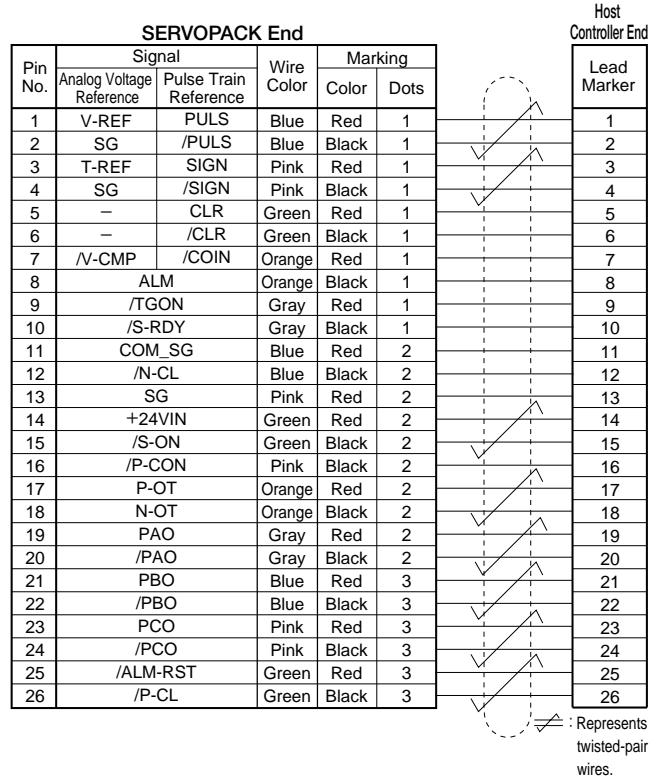

- (4) Cable with Loose Wires at One End for CN3  
 (Model: JZSP-CF1G00-□□-E)

- External Dimensions (Units: mm)

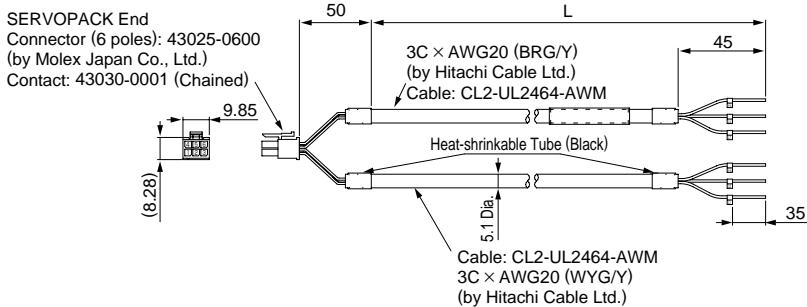

- Specifications

Pin No.	Cable Color	Signal
1	Green/yellow	FG
2	Green/yellow	FG
3	Blue	L2
4	White	C2
5	Yellow	C1
6	Red	L1

DC

Analog/Pulse Type SERVOPACKS



## Selecting Cables

### (5) Digital Operator (Model: JUSP-OP05A-1-E) (Units: mm)

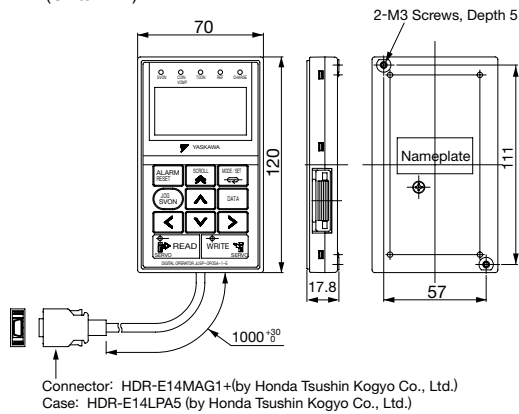

### (6) Digital Operator Relay Cable for CN5 (Model: JZSP-CF1S00-A3-E)

#### • External Dimensions (Units: mm)

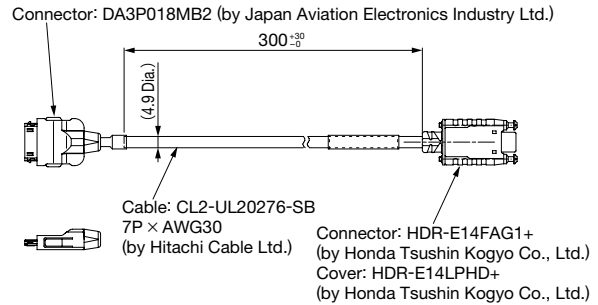

### (7) Analog Monitor Unit (Model: JUSP-PC001-E)

#### • External Dimensions (Units: mm)

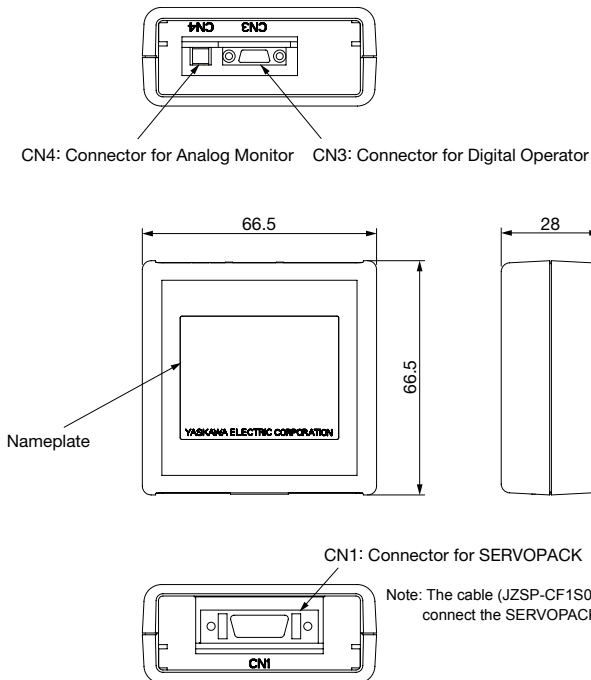

### (8) Analog Monitor Unit Connection Cable for CN5 (Model: JZSP-CF1S05-A3-E)

#### • External Dimensions (Units: mm)

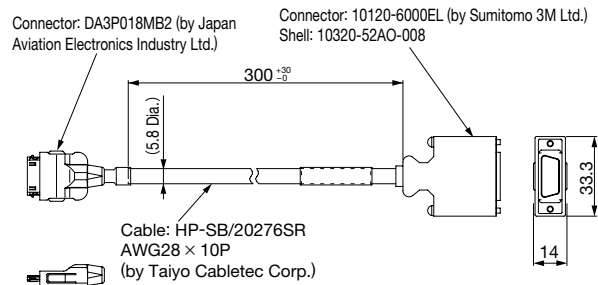

## Selecting Cables

### (9) Analog Monitor Unit Cable for CN4 (Model: JZSP-CA01-E)

#### • External Dimensions (Units: mm)

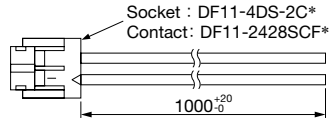

\* : Manufactured by Hirose Electric Corporation.

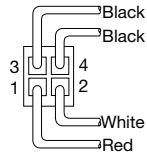

View from Cable End

#### □ Specifications

Pin No.	Cable Color	Signal	Standard Settings
1	Red	Analog Monitor 2	Motor speed : 1V/1000 min-1
2	White	Analog Monitor 1	Torque reference : 1V/100□ rated torque
3, 4	Black (2 cables)	GND(0V)	-

Note : The specifications above are factory settings. Monitor specifications can be changed by changing parameters Pn006 and Pn007.

### (10) Connection Cable for Personal Computer for CN7 (Model: JZSP-CVS06-02-E)

#### • External Dimensions (Units: mm)

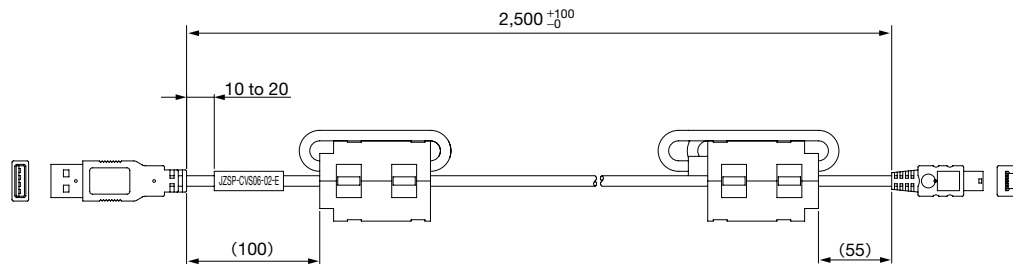

**IMPORTANT** Use a cable specified by Yaskawa.  
When using other cables, operation cannot be guaranteed.

DC

Analog/Pulse Type SERVOPACKs

# MECHATROLINK-II Communications Reference SERVOPACKs

## SGDV-□□□E11 (For Rotary Servomotors)



### Model Designations

Σ-V Series  
SGDV  
SERVOPACKs  
with DC Power Input
1st+2nd+3rd digits
4th digit
5th+6th digits
7th digit
8th+9th+10th digits
11th+12th digits
13th digit

S G D V - 2R9 E 11 A 002 00 0

**1st+2nd+3rd digits** Current

Voltage	Code	Applicable Servomotor Max. Capacity kW
24 VDC/	1R7	0.011
48 VDC	2R9	0.030

**4th digit** Power Supply Voltage

Code	Specifications
E	48 VDC*

**5th+6th digits** Interface

Code	Specifications
11	MECHATROLINK-II communications Reference (for rotary servomotors)

**7th digit** Design Revision Order

A, B...

**8th+9th+10th digits** Options (hardware)

Code	Specifications
002	Base-mounted, varnish(standard)

**11th+12th digits** Options (software)

Code	Specifications
00	Standard

**13th digit** Options (parameter)

Code	Specifications
0	Standard

\*: Either a 24-VDC or a 48-VDC power supply can be used for the main circuit. The control power supply must be 24 VDC.  
Note: If the option codes digits 8 to 13 are all zeros, they are omitted.

## Features

### ● Real-time communications

MECHATROLINK-II communications enable high-speed control for 30 stations at a maximum transmission speed of 10 Mbps in a transmission cycle from 250  $\mu$ s to 4 ms (set by the host controller). Such a high transmission speed allows real-time transmission of various data required for control.

### ● Cost savings

Thirty stations can be connected to a single MECHATROLINK-II transmission line, so wiring costs and time are greatly reduced. Also, only one signal connector is required on the host controller. And, the all-digital network eliminates the need for conversion from digital to analog for speed/torque references and for a pulse generator to generate position references.

### ● High-precision motion control

The SGD V SERVOPACK when connected to the host controller in the MECHATROLINK-II network provides not only torque, position, and speed control but also synchronized phase control that requires advanced control technology. The control mode can be changed online so that the machine can move smoothly in complex motions with great efficiency.

## Ratings

SERVOPACK Model SGD V-□□□□	1R7E		2R9E	
Applicable Servomotor Max. Capacity kW	0.011		0.030	
Continuous Output Current Arms	1.7		2.9	
Max. Output Current Arms	4.1		8.6	
Regenerative Resistors	None			
Main Circuit*	24 VDC $\pm$ 15%	48 VDC $\pm$ 15%	24 VDC $\pm$ 15%	48 VDC $\pm$ 15%
Control Circuit	24 VDC $\pm$ 15%			

\*: Either a 24-VDC or a 48-VDC power supply can be used for the main circuit. When a 24-VDC power supply is used, the torque-motor speed characteristics for a 48 VDC cannot be achieved. For details, refer to Torque-Motor Speed Characteristics on page 6.

### ● SERVOPACK Overload Characteristics

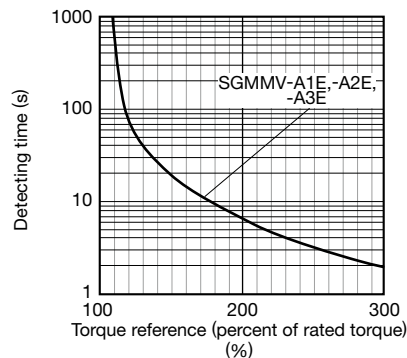
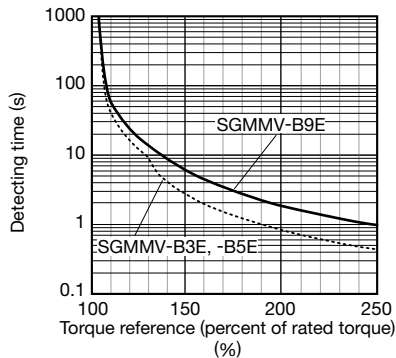

Note: Overload characteristics shown above do not guarantee continuous duty of 100% or more output. Use a servomotor with effective torque within the continuous duty zone of Torque-Motor Speed Characteristics.

# Specifications

Items		Specifications		
Control Method		PWM control, sine-wave driven		
Feedback		Serial encoder: 17-bit (incremental/absolute)		
Operating Conditions	Ambient Temperature	0 to +55°C		
	Storage Temperature	-20 to +85°C		
	Ambient Humidity	90%RH or less	With no freezing or condensation	
	Storage Humidity	90%RH or less		
	Vibration Resistance	4.9 m/s <sup>2</sup>		
	Shock Resistance	19.6 m/s <sup>2</sup>		
	Protection Class	IP10	An environment that satisfies the following conditions. <ul style="list-style-type: none"> <li>• Free of corrosive or flammable gases</li> <li>• Free of exposure to water, oil, or chemicals</li> <li>• Free of dust, salts, or iron dust</li> </ul>	
	Pollution Degree	2		
	Altitude	1000 m or less		
Others	Do not use SERVOPACKs in the following locations: <ul style="list-style-type: none"> <li>• Locations subject to static electricity noise, strong electromagnetic/magnetic fields, radioactivity</li> </ul>			
Applicable Standards		UL508C EN55011/A1, EN61000-6-2, EN61800-3, EN61800-5-1		
Mounting		Base-mounted		
Performance	Speed Control Range		1 : 5000 (The lower limit of the speed control range must be lower than the point at which the rated torque does not cause the servomotor to stop.)	
	Speed Regulation <sup>*1</sup>	Load Fluctuation	0% to 100% load: ±0.01% max. (at rated speed)	
		Voltage Fluctuation	Rated voltage: ±10% : 0% (at rated speed)	
		Temperature Fluctuation	25±25°C : ±0.1% max. (at rated speed)	
	Torque Control Tolerance (Repeatability)		±1%	
Soft Start Time Setting <sup>*2</sup>		0 to 10 s (can be set individually for acceleration and deceleration.)		
I/O Signal	Sequence Input	Input Signals which can be allocated	Number of Channels	3 channels
			Functions	<ul style="list-style-type: none"> <li>• Homing deceleration switch signal (/DEC)</li> <li>• External latch signals (/EXT 1)</li> <li>• Forward run prohibited (P-OT), reverse run prohibited (N-OT)</li> <li>• Forward external torque limit (/P-CL), reverse external torque limit (/N-CL)</li> </ul> Positive and negative logic can be changed.
	Sequence Output	Output Signals which can be allocated	Fixed Output	Servo alarm (ALM)
			Number of Channels	3 channels
		Functions	<ul style="list-style-type: none"> <li>• Positioning completion (/COIN)</li> <li>• Speed limit detection (/VLT)</li> <li>• Speed coincidence detection (/V-CMP)</li> <li>• Brake (/BK)</li> <li>• Rotation detection (/TGON)</li> <li>• Warning (/WARN)</li> <li>• Servo ready (/S-RDY)</li> <li>• Near (/NEAR)</li> <li>• Torque limit detection (/CLT)</li> </ul> Positive and negative logic can be changed.	
Communications	Computer (USB)	Compatible with SigmaWin+. Compliant with the USB1.1 standard (12 Mbps)		
Display		Servo alarm (ALM): red; servo ready (RDY): green; communications(COM): green		
DIP Switches for MECHATROLINK-II Communication Settings		DIP switches: SW1 and SW2	Number of poles: 4/DIP switch (two DIP switches)*3	
Analog Monitor		Number of points: 2 Output voltage: ±10 VDC (linearity effective range: ±8 V) Output through the analog monitor unit (model: JUSP-PC001-E)		

\*1: Speed regulation is defined as follows:

$$\text{Speed regulation} = \frac{\text{No-load motor speed} - \text{Total load motor speed}}{\text{Rated motor speed}} \times 100\%$$

The motor speed may change due to voltage fluctuation or temperature fluctuation.

The ratio of speed changes to the rated speed represent speed regulation due to voltage and temperature fluctuations.

\*2 : For information on soft start, refer to 4.2.10 Velocity Control (VELCTRL: 3CH) in the AC Servo Drives  $\Sigma$ -V Series USER'S MANUAL MECHATROLINK-II Commands

\*3 : For details, refer to 4.1.1 Setting Switches SW1 and SW2 in the AC Servo Drives DC Power Input  $\Sigma$ -V Series USER'S MANUAL Design and Maintenance

(Cont'd)

## Specifications

Items	Specifications	
Dynamic Brake (DB)	Not available	
Regenerative Processing	Not available	
Overtravelling (OT) Prevention	Decelerate to a stop or coast to a stop when overtraveling is detected and an overtravel signal (P-OT or N-OT) is input.	
Protective Functions	Overcurrent, Overvoltage, low voltage, overload, etc.	
Utility Functions	Gain adjustment, alarm history, JOG operation, origin search, etc.	
MECHATROLINK-II Communications	Communications Protocol	MECHATROLINK-II
	Station Address	41H to 5FH (max. number of slaves: 30) Set station addresses with combinations of SW1 and SW2 settings.
	Transmission Speed	10 Mbps, 4 Mbps Set by using the SW2 DIP switch.
	Transmission Cycle	250 $\mu$ s or 0.5 ms to 4.0 ms (increments of 0.5 ms)
	Number of Transmission Bytes	Can be switched between 17 bytes /station and 32 bytes / station. Set by using the SW2 DIP switch.
Command Method	Performance	Position control, speed control, and torque control through MECHATROLINK-II communications
	Command Input	MECHATROLINK-II commands (for sequence, motion, data setting/reference, monitoring, adjustment, and other commands.)

## Power Supply Capacities and Power Losses

The following table shows SERVOPACK's power supply capacities and power losses at the rated output.

Main Circuit Power Supply	Applicable Servomotor Max. Capacity W	SERVOPACK Model SGDV-	Main Circuit Power Supply Capacity per SERVOPACK W	Output Current Arms	Main Circuit Power Loss W	Regenerative Resistor Power Loss W	Control Circuit Power Loss W	Total Power Loss W
24 VDC	11	1R7E	108	1.7	3.4	-	7.2	10.6
	30	2R9E	165	2.9	6.9			14.1
48 VDC	11	1R7E	169	1.7	3.4	-	7.2	10.6
	30	2R9E	411	2.9	6.9			14.1

Note: These power supply capacities are net values at instantaneous maximum loads.

## Selecting Cables

- Cables for **CN1** **CN3** **CN5** **CN6** **CN7** (MECHATROLINK-II Communications Reference SERVOPACKs)

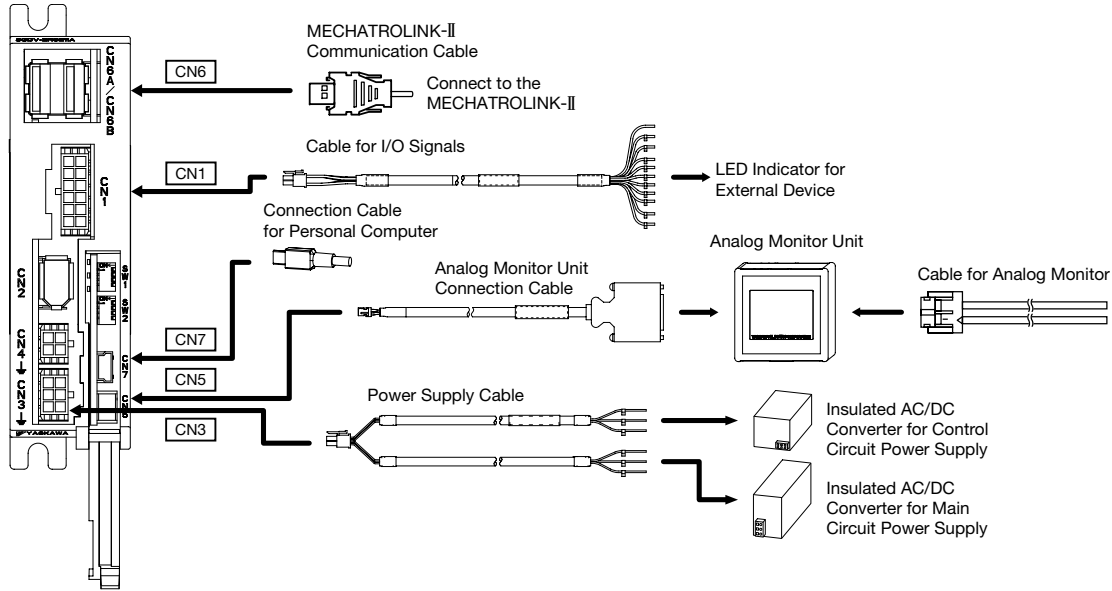

Name	Length	Order No.	Specifications	Details
<b>CN1</b> Cables for I/O Signals	1 m	JZSP-CF1I02-1-E		(1)
	2 m	JZSP-CF1I02-2-E		
	3 m	JZSP-CF1I02-3-E		
<b>CN3</b> Power Supply Cables	1 m	JZSP-CF1G00-01-E		(2)
	2 m	JZSP-CF1G00-02-E		
	3 m	JZSP-CF1G00-03-E		
	4 m	JZSP-CF1G00-04-E		
	5 m	JZSP-CF1G00-05-E		
	6 m	JZSP-CF1G00-06-E		
	7 m	JZSP-CF1G00-07-E		
	8 m	JZSP-CF1G00-08-E		
	9 m	JZSP-CF1G00-09-E		
	10 m	JZSP-CF1G00-10-E		
<b>CN5</b> Analog Monitor Unit Cable	Analog Monitor Unit			(3)
	Analog Monitor Unit Connection Cable	0.3 m	JZSP-CF1S06-A3-E	(4)
	Cables for Analog Monitor	1 m	JZSP-CA01-E	(5)
<b>CN6A</b> <b>CN6B</b> MECHATROLINK-II Communication Cable	Cables with Connectors at Both Ends	0.5 to 50 m	JEPMC-W6002-□□-E	(6)
	Cables with Connectors at Both Ends (with Ferrite Core)	0.5 to 50 m	JEPMC-W6003-□□-E	(7)
	Terminator		JEPMC-W6022-E	(8)
<b>CN7</b> Connection Cables for Personal Computer	2.5 m	JZSP-CVS06-02-E		(9)

DC

MECHATROLINK-II Type SERVOPACKS



## Selecting Cables

### (1) Cable with Loose Wires at One End for CN1

(Model: JZSP-CF1102-□-E)

- External Dimensions (Units: mm)

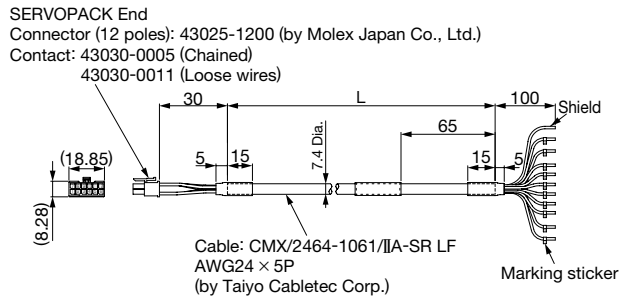

Model	Cable Length
JZSP-CF1102-1-E	1 m
JZSP-CF1102-2-E	2 m
JZSP-CF1102-3-E	3 m

### ● Cable with Loose Wires at One End for CN1

Connection Diagram of JZSP-CF1102-□-E Cable

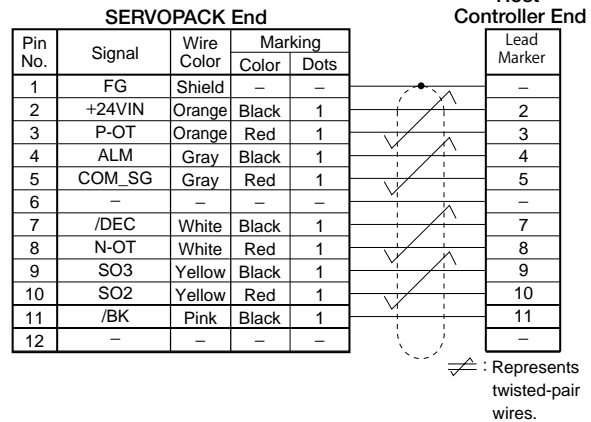

### (2) Cable with Loose Wires at One End for CN3

(Model: JZSP-CF1G00-□□-E)

- External Dimensions (Units: mm)

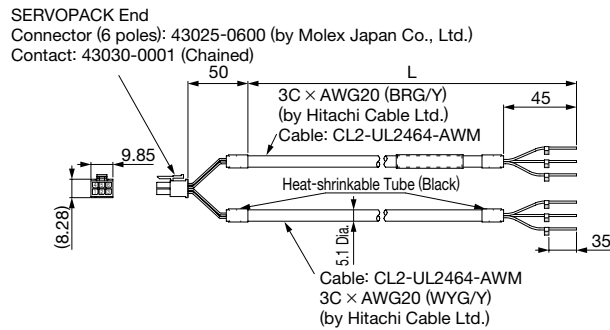

Model	Cable Length
JZSP-CF1G00-01-E	1 m
JZSP-CF1G00-02-E	2 m
JZSP-CF1G00-03-E	3 m
JZSP-CF1G00-04-E	4 m
JZSP-CF1G00-05-E	5 m
JZSP-CF1G00-06-E	6 m
JZSP-CF1G00-07-E	7 m
JZSP-CF1G00-08-E	8 m
JZSP-CF1G00-09-E	9 m
JZSP-CF1G00-10-E	10 m

### • Specifications

Pin No.	Cable Color	Signal
1	Green/yellow	FG
2	Green/yellow	FG
3	Blue	L2
4	White	C2
5	Yellow	C1
6	Red	L1

## Selecting Cables

### (3) Analog Monitor Unit

(Model: JUSP-PC001-E)

- External Dimensions (Units: mm)

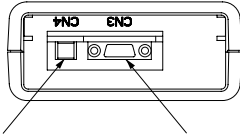

CN4: Connector for Analog Monitor    CN3: Connector for Digital Operator

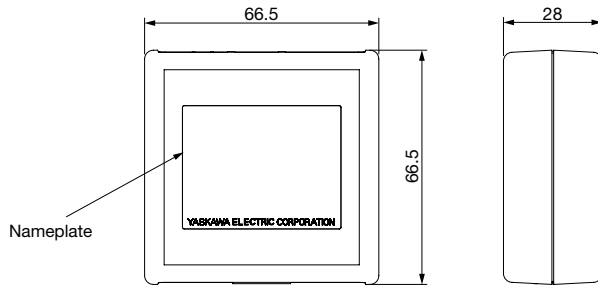

CN1: Connector for SERVOPACK

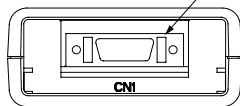

Note: The cable (JZSP-CF1S06-A3-E) to connect the SERVOPACK is not included.

### (4) Analog Monitor Unit Connection Cable for CN5

(Model: JZSP-CF1S06-A3-E)

- External Dimensions (Units: mm)

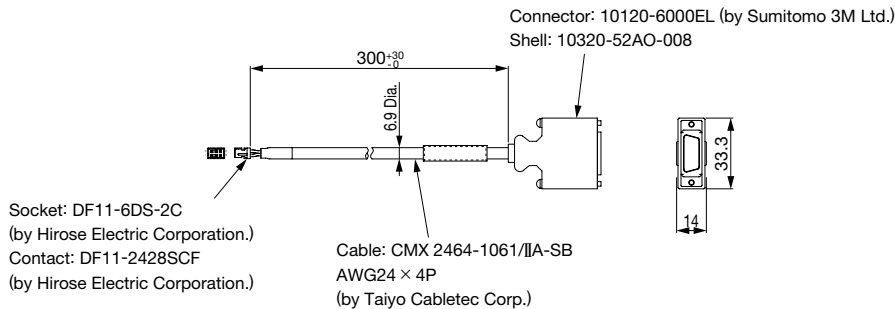

DC

MECHATROLINK-II Type SERVOPACKs

## Selecting Cables

### (5) Analog Monitor Unit Cable for CN4 (Model: JZSP-CA01-E)

- External Dimensions (Units: mm)

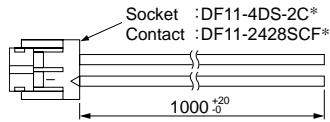

\* : Manufactured by Hirose Electric Corporation.

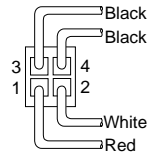

View from Cable End

- Specifications

Pin No.	Cable Color	Signal	Standard Settings
1	Red	Analog Monitor 2	Motor speed : 1V/1000 min-1
2	White	Analog Monitor 1	Torque reference : 1V/100% rated torque
3, 4	Black (2 cables)	GND (0V)	-

Note : The specifications above are factory settings. Monitor specifications can be changed by changing parameters Pn006 and Pn007.

### (6) Cable with Connectors at Both Ends for CN6

(Model: JEPMC-W6002-□□-E)

- External Dimensions (Units: mm)

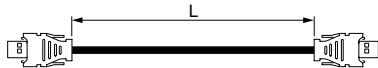

Model	Cable Length (L)
JEPMC-W6002-A5-E	0.5 m
JEPMC-W6002-01-E	1.0 m
JEPMC-W6002-03-E	3.0 m
JEPMC-W6002-05-E	5.0 m
JEPMC-W6002-10-E	10.0 m
JEPMC-W6002-20-E	20.0 m
JEPMC-W6002-30-E	30.0 m
JEPMC-W6002-40-E	40.0 m
JEPMC-W6002-50-E	50.0 m

### (7) Cable with Connectors at Both Ends (with Ferrite Core) for CN6

(Model: JEPMC-W6003-□□-E)

- External Dimensions (Units: mm)

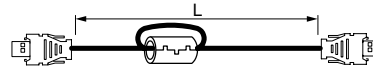

Model	Cable Length (L)
JEPMC-W6003-A5-E	0.5 m
JEPMC-W6003-01-E	1.0 m
JEPMC-W6003-03-E	3.0 m
JEPMC-W6003-05-E	5.0 m
JEPMC-W6003-10-E	10.0 m
JEPMC-W6003-20-E	20.0 m
JEPMC-W6003-30-E	30.0 m
JEPMC-W6003-40-E	40.0 m
JEPMC-W6003-50-E	50.0 m

**IMPORTANT** Use a MECHATROLINK-II communications cable specified by Yaskawa. When using other cables, noise resistance may be reduced, and operation cannot be guaranteed.

### (8) MECHATROLINK-II Terminator for CN6 (Model : JEPMC-W6022-E)

- External Dimensions (Units: mm)

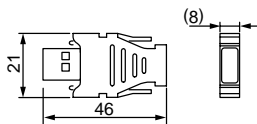

## Selecting Cables

(9) Connection Cable for Personal Computer for CN7  
(Model: JZSP-CVS06-02-E)

- External Dimensions (Units: mm)

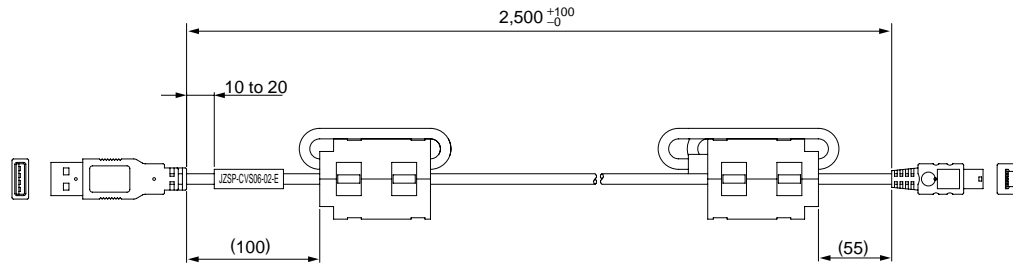

**IMPORTANT** Use a cable specified by Yaskawa.  
When using other cables, operation cannot be guaranteed.

# MECHATROLINK-III Communications Reference SERVOPACKs

## SGDV-□□□E21 (For Rotary Servomotors)



### Model Designations

S G D V - 2R9 E 21 A 002 00 0

Σ-V Series  
SGDV  
SERVOPACKs  
with DC Power Input

1st+2nd+3rd digits

4th digit

5th+6th digits

7th digit

8th+9th+10th digits

11th+12th digits

13th digit

1st+2nd+3rd digits Current

Voltage	Code	Applicable Servomotor Max. Capacity kW
24 VDC/	1R7	0.011
48 VDC	2R9	0.030

4th digit Power Supply Voltage

Code	Specifications
E	48 VDC*

5th+6th digits Interface

Code	Specifications
21	MECHATROLINK-III communications Reference (for rotary servomotors)

7th digit Design Revision Order

A, B...

8th+9th+10th digits Options (hardware)

Code	Specifications
002	Base-mounted, varnish(standard)

11th+12th digits Options (software)

Code	Specifications
00	Standard

13th digit Options (parameter)

Code	Specifications
0	Standard

\*: Either a 24-VDC or a 48-VDC power supply can be used for the main circuit. The control power supply must be 24 VDC.  
Note: If the option codes digits 8 to 13 are all zeros, they are omitted.

## Features

### ● Real-time communications

MECHATROLINK-III communications enable high-speed control for 62 stations at a transmission speed of 100 Mbps in a transmission cycle from 125  $\mu$ s to 4 ms (set by the host controller). Such a high transmission speed allows real-time transmission of various data required for control.

### ● Cost savings

The 62 stations can be connected to a single MECHATROLINK-III transmission line, so wiring costs and time are greatly reduced. Also, only one signal connector is required on the host controller. And, the all-digital network eliminates the need for conversion from digital to analog for speed/torque references and for a pulse generator to generate position references.

### ● High-precision motion control

The SGD V SERVOPACK when connected to the host controller in the MECHATROLINK-III network provides not only torque, position, and speed control but also synchronized phase control that requires advanced control technology. The control mode can be changed online so that the machine can move smoothly in complex motions with great efficiency.

## Ratings

SERVOPACK Model SGD V-□□□□	1R7E		2R9E	
Applicable Servomotor Max. Capacity kW	0.011		0.030	
Continuous Output Current Arms	1.7		2.9	
Max. Output Current Arms	4.1		8.6	
Regenerative Resistors	None			
Main Circuit*	24 VDC $\pm$ 15□	48 VDC $\pm$ 15□	24 VDC $\pm$ 15□	48 VDC $\pm$ 15□
Control Circuit	24 VDC $\pm$ 15□			

\*: Either a 24-VDC or a 48-VDC power supply can be used for the main circuit. When a 24-VDC power supply is used, the torque-motor speed characteristics for a 48 VDC cannot be achieved.

### ● SERVOPACK Overload Characteristics

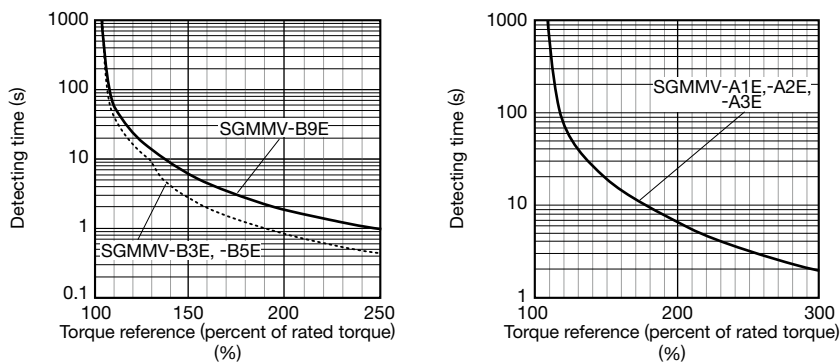

Note: Overload characteristics shown above do not guarantee continuous duty of 100% or more output. Use a servomotor with effective torque within the continuous duty zone of Torque-Motor Speed Characteristics.

# Specifications

Items		Specifications		
Control Method		PWM control, sine-wave driven		
Feedback		Serial encoder: 17-bit (incremental/absolute)		
Operating Conditions	Ambient Temperature	0 to +55°C		
	Storage Temperature	-20 to +85°C		
	Ambient Humidity	90%RH or less	With no freezing or condensation	
	Storage Humidity	90%RH or less		
	Vibration Resistance	4.9 m/s <sup>2</sup>		
	Shock Resistance	19.6 m/s <sup>2</sup>		
	Protection Class	IP10	An environment that satisfies the following conditions. <ul style="list-style-type: none"> <li>• Free of corrosive or flammable gases</li> <li>• Free of exposure to water, oil, or chemicals</li> <li>• Free of dust, salts, or iron dust</li> </ul>	
	Pollution Degree	2		
	Altitude	1000 m or less		
Others	Do not use SERVOPACKs in the following locations: <ul style="list-style-type: none"> <li>• Locations subject to static electricity noise, strong electromagnetic/magnetic fields, radioactivity</li> </ul>			
Applicable Standards		UL508C EN55011/A1 □ EN61000-6-2 □ EN61800-3 □ EN61800-5-1		
Mounting		Base-mounted		
Performance	Speed Control Range		1 : 5000 (The lower limit of the speed control range must be lower than the point at which the rated torque does not cause the servomotor to stop.)	
	Speed Regulation**	Load Fluctuation	0% to 100% load: ±0.01% max. (at rated speed)	
		Voltage Fluctuation	Rated voltage: ±10% : 0% (at rated speed)	
		Temperature Fluctuation	25±25°C : ±0.1% max. (at rated speed)	
	Torque Control Tolerance (Repeatability)		±1%	
Soft Start Time Setting		0 to 10 s (can be set individually for acceleration and deceleration.)		
I/O Signal	Sequence Input	Input Signals which can be allocated	Number of Channels	3 channels
			Functions	<ul style="list-style-type: none"> <li>• Homing deceleration switch signal (/DEC)</li> <li>• External latch signals (/EXT 1)</li> <li>• Forward run prohibited (P-OT), reverse run prohibited (N-OT)</li> <li>• Forward external torque limit (/P-CL), reverse external torque limit (/N-CL)</li> </ul> Positive and negative logic can be changed.
	Sequence Output	Output Signals which can be allocated	Fixed Output	Servo alarm (ALM)
			Number of Channels	3 channels
		Functions	<ul style="list-style-type: none"> <li>• Positioning completion (/COIN)</li> <li>• Speed limit detection (/VLT)</li> <li>• Speed coincidence detection (/V-CMP)</li> <li>• Brake (/BK)</li> <li>• Rotation detection (/TGON)</li> <li>• Warning (/WARN)</li> <li>• Servo ready (/S-RDY)</li> <li>• Near (/NEAR)</li> <li>• Torque limit detection (/CLT)</li> </ul> Positive and negative logic can be changed.	
Communications	Computer (USB)	Compatible with SigmaWin+. Compliant with the USB1.1 standard (12 Mbps)		
Display		Servo alarm (ALM): red, servo ready (RDY): green, link 1 (LK1): green, link 2 (LK2): green, communications (COM): green		
DIP Switches for MECHATROLINK-III Communication Settings		S1 DIP switch	Number of poles: 8 <sup>2</sup>	
		S2 DIP switch	Number of poles: 4 <sup>2</sup>	
Analog Monitor		Number of points: 2 Output voltage: ±10 VDC (linearity effective range: ±8 V) Output through the analog monitor unit (model: JUSP-PC001-E)		

\*1: Speed regulation is defined as follows:

$$\text{Speed regulation} = \frac{\text{No-load motor speed} - \text{Total load motor speed}}{\text{Rated motor speed}} \times 100\%$$

The motor speed may change due to voltage fluctuation or temperature fluctuation.

The ratio of speed changes to the rated speed represent speed regulation due to voltage and temperature fluctuations.

\*2: For details, refer to 4.1.1 Setting Switches S1 and S2 in the AC Servo Drives DC Power Input Σ-V Series USER'S MANUAL Design and Maintenance

(Cont'd)

## Specifications

Items	Specifications	
Dynamic Brake (DB)	Not available	
Regenerative Processing	Not available	
Overtravelling (OT) Prevention	Decelerate to a stop or coast to a stop when overtraveling is detected and an overtravel signal (P-OT or N-OT) is input.	
Protective Functions	Overcurrent, Overvoltage, low voltage, overload, etc.	
Utility Functions	Gain adjustment, alarm history, JOG operation, origin search, etc.	
MECHATROLINK-III Communications	Communications Protocol	MECHATROLINK-III
	Station Address	03H to EFH (max. number of slaves: 62) Set by using the S1 DIP switch.
	Transmission Speed	100 Mbps
	Transmission Cycle	125 $\mu$ s, 250 $\mu$ s, 500 $\mu$ s, 750 $\mu$ s, 1 ms to 4 ms (increments of 0.5 ms)
	Number of Transmission Bytes	Can be switched between 16 bytes/station, 32 bytes/station, or 48 bytes/station Set by using the S2 DIP switch.
Command Method	Performance	Position control, speed control, and torque control through MECHATROLINK-III communications
	Command Input	MECHATROLINK commands (for sequence, motion, data setting/reference, monitoring, adjustment, and other commands.)
	Profile	MECHATROLINK-II compatible profile MECHATROLINK-III standard servo profile



## Power Supply Capacities and Power Losses

The following table shows SERVOPACK's power supply capacities and power losses at the rated output.

Main Circuit Power Supply	Applicable Servomotor Max. Capacity W	SERVOPACK Model SGD V-	Main Circuit Power Supply Capacity per SERVOPACK W	Output Current Arms	Main Circuit Power Loss W	Regenerative Resistor Power Loss W	Control Circuit Power Loss W	Total Power Loss W
24 VDC	11	1R7E	108	1.7	3.4	-	7.2	10.6
	30	2R9E	165	2.9	6.9			14.1
48 VDC	11	1R7E	169	1.7	3.4	-	7.2	10.6
	30	2R9E	411	2.9	6.9			14.1

Note: These power supply capacities are net values at instantaneous maximum loads.

## Selecting Cables

- Cables for **CN1** **CN3** **CN5** **CN6** **CN7** (MECHATROLINK-III Communications Reference SERVOPACKs)

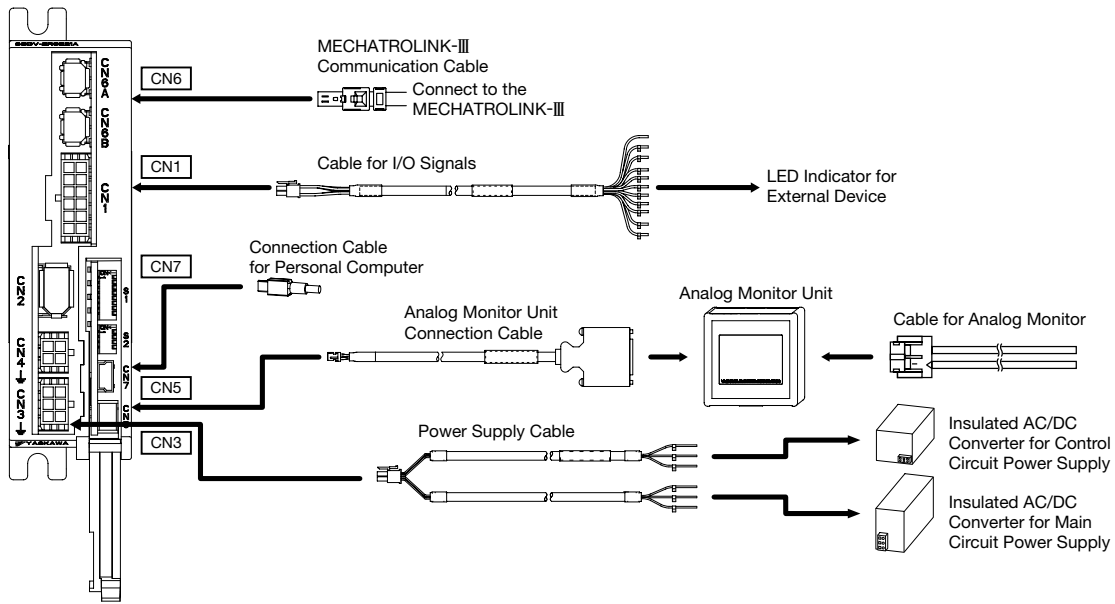

Name	Length	Order No.	Specifications	Details	
<b>CN1</b> Cables for I/O Signals	1 m	JZSP-CF1102-1-E		(1)	
	2 m	JZSP-CF1102-2-E			
	3 m	JZSP-CF1102-3-E			
<b>CN3</b> Power Supply Cables	1 m	JZSP-CF1G00-01-E	SERVOPACK End      Power Supply End 	(2)	
	2 m	JZSP-CF1G00-02-E			
	3 m	JZSP-CF1G00-03-E			
	4 m	JZSP-CF1G00-04-E			
	5 m	JZSP-CF1G00-05-E			
	6 m	JZSP-CF1G00-06-E			
	7 m	JZSP-CF1G00-07-E			
	8 m	JZSP-CF1G00-08-E			
	9 m	JZSP-CF1G00-09-E			
	10 m	JZSP-CF1G00-10-E			
<b>CN5</b> Analog Monitor Unit Cable	Analog Monitor Unit			(3)	
	Analog Monitor Unit Connection Cable	0.3 m	JZSP-CF1S06-A3-E	SERVOPACK End      Analog Monitor Unit End 	(4)
	Cables for Analog Monitor	1 m	JZSP-CA01-E	Analog Monitor Unit End 	(5)
<b>CN6A</b> <b>CN6B</b> MECHATROLINK-III Communication Cable	Cables with Connectors at Both Ends	0.2 to 50 m	JEPMC-W6012-□□-E		(6)
	Cables with Connectors at Both Ends (with Ferrite Core)	10 to 50 m	JEPMC-W6013-□□-E		(7)
	Cable with Loose wire at One End	0.5 to 50 m	JEPMC-W6014-□□-E		(8)
<b>CN7</b> Connection Cables for Personal Computer	2.5 m	JZSP-CVS06-02-E	Cable with Connectors at Both Ends 	(9)	

DC

MECHATROLINK-III Type SERVOPACKs

## Selecting Cables

### (1) Cable with Loose Wires at One End for CN1

(Model: JZSP-CF1102-□-E)

- External Dimensions (Units: mm)

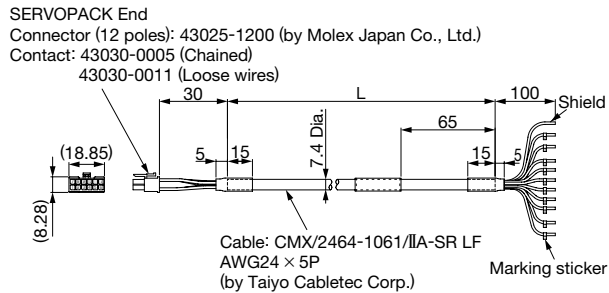

Model	Cable Length
JZSP-CF1102-1-E	1 m
JZSP-CF1102-2-E	2 m
JZSP-CF1102-3-E	3 m

### ● Cable with Loose Wires at One End for CN1

Connection Diagram of JZSP-CF1102-□-E Cable

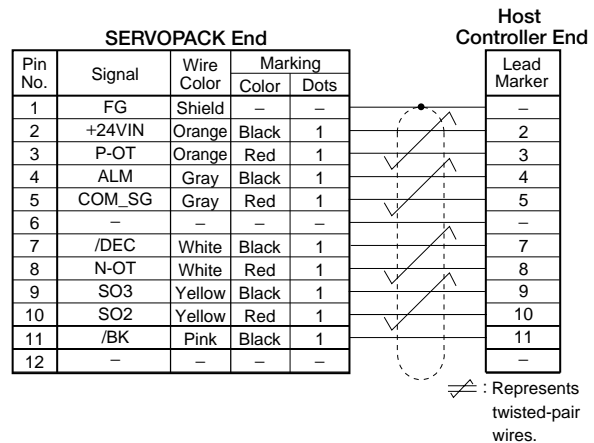

### (2) Cable with Loose Wires at One End for CN3

(Model: JZSP-CF1G00-□□-E)

- External Dimensions (Units: mm)

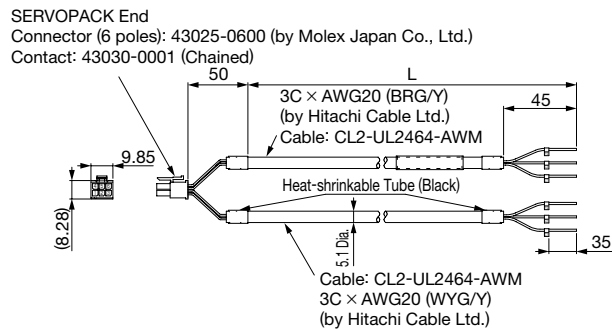

Model	Cable Length
JZSP-CF1G00-01-E	1 m
JZSP-CF1G00-02-E	2 m
JZSP-CF1G00-03-E	3 m
JZSP-CF1G00-04-E	4 m
JZSP-CF1G00-05-E	5 m
JZSP-CF1G00-06-E	6 m
JZSP-CF1G00-07-E	7 m
JZSP-CF1G00-08-E	8 m
JZSP-CF1G00-09-E	9 m
JZSP-CF1G00-10-E	10 m

### • Specifications

Pin No.	Cable Color	Signal
1	Green/yellow	FG
2	Green/yellow	FG
3	Blue	L2
4	White	C2
5	Yellow	C1
6	Red	L1

## Selecting Cables

### (3) Analog Monitor Unit (Model: JUSP-PC001-E)

- External Dimensions (Units: mm)

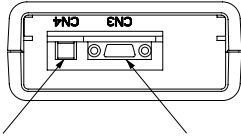

CN4: Connector for Analog Monitor    CN3: Connector for Digital Operator

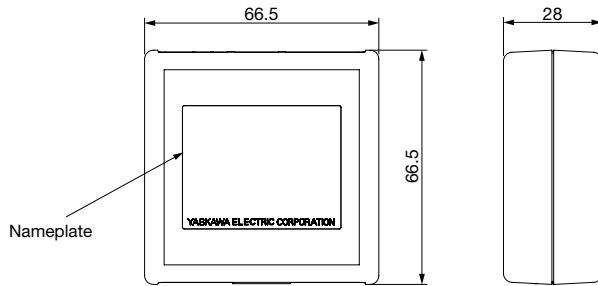

CN1: Connector for SERVOPACK

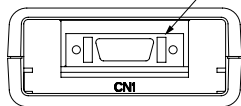

Note: The cable (JZSP-CF1S06-A3-E) to connect the SERVOPACK is not included.

### (4) Analog Monitor Unit Connection Cable for CN5 (Model: JZSP-CF1S06-A3-E)

- External Dimensions (Units: mm)

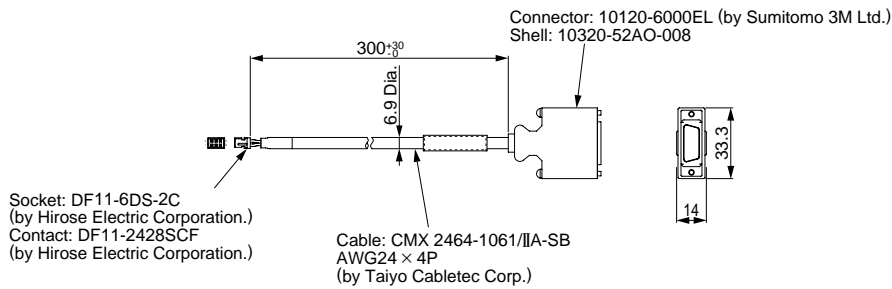

DC

MECHATROLINK-III Type SERVOPACKs

## Selecting Cables

### (5) Analog Monitor Unit Cable for CN4 (Model: JZSP-CA01-E)

- External Dimensions (Units: mm)

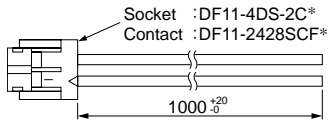

\* : Manufactured by Hirose Electric Corporation.

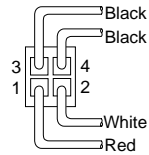

View from Cable End

- Specifications

Pin No.	Cable Color	Signal	Standard Settings
1	Red	Analog Monitor 2	Motor speed : 1V/1000 min <sup>-1</sup>
2	White	Analog Monitor 1	Torque reference : 1V/100□ rated torque
3, 4	Black (2 cables)	GND (0V)	-

Note : The specifications above are factory settings. Monitor specifications can be changed by changing parameters Pn006 and Pn007.

### (6) Cables with Connectors at Both Ends for CN6

(Model: JEPMC-W6012-□□-E)

- External Dimensions (Units: mm)

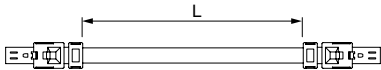

Model	Cable Length (L)
JEPMC-W6012-A2-E	0.2 m
JEPMC-W6012-A5-E	0.5 m
JEPMC-W6012-01-E	1 m
JEPMC-W6012-02-E	2 m
JEPMC-W6012-03-E	3 m
JEPMC-W6012-04-E	4 m
JEPMC-W6012-05-E	5 m
JEPMC-W6012-10-E	10 m
JEPMC-W6012-20-E	20 m
JEPMC-W6012-30-E	30 m
JEPMC-W6012-50-E	50 m

### (7) Cables with Connectors at Both Ends (With Ferrite Core) for CN6

(Model: JEPMC-W6013-□□-E)

- External Dimensions (Units: mm)

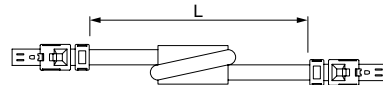

Model	Cable Length (L)
JEPMC-W6013-10-E	10 m
JEPMC-W6013-20-E	20 m
JEPMC-W6013-30-E	30 m
JEPMC-W6013-50-E	50 m

### (8) Cable with Loose Wire at One End for CN6

(Model: JEPMC-W6014-□□-E)

- External Dimensions (Units: mm)

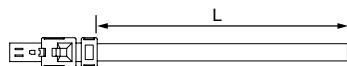

Model	Cable Length (L)
JEPMC-W6014-A5-E	0.5 m
JEPMC-W6014-01-E	1 m
JEPMC-W6014-03-E	3 m
JEPMC-W6014-05-E	5 m
JEPMC-W6014-10-E	10 m
JEPMC-W6014-30-E	30 m
JEPMC-W6014-50-E	50 m

#### IMPORTANT

Use a MECHATROLINK-III communications cable specified by Yaskawa. When using other cables, noise resistance may be reduced, and operation cannot be guaranteed.

## Selecting Cables

(9) Connection Cable for Personal Computer for CN7  
(Model: JZSP-CVS06-02-E)

- External Dimensions (Units: mm)

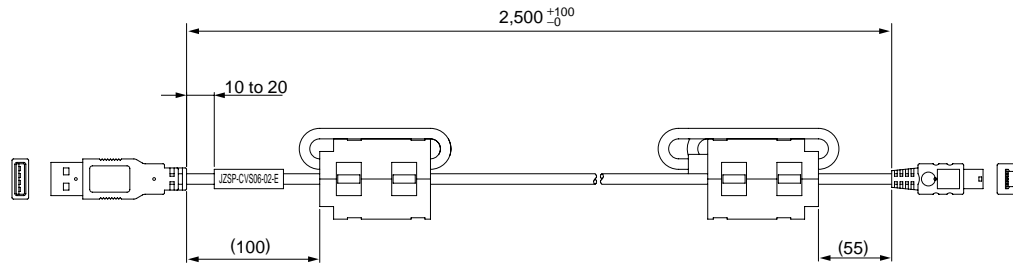

**IMPORTANT** Use a cable specified by Yaskawa.  
When using other cables, operation cannot be guaranteed.



# DC SERVOPACK External Dimensions

External Dimensions Units: mm

## ● Base-Mounted SERVOPACKS

(1) Analog Voltage Reference, Model: SGDV-1R7ES1A, -2R9ES1A

Pulse Train Reference, Model: SGDV-1R7EP1A, -2R9EP1A

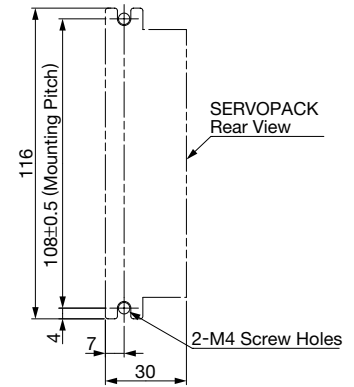
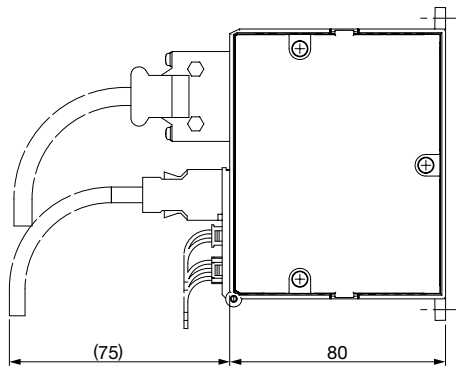
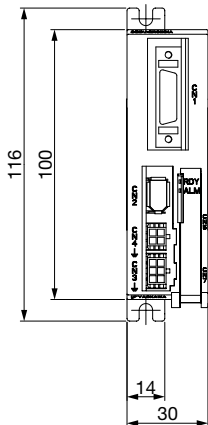

Mounting Hole Diagram

Approx. Mass: 0.3 kg

(2) MECHATROLINK-II Communications Reference, Model: SGDV-1R7E11A, -2R9E11A

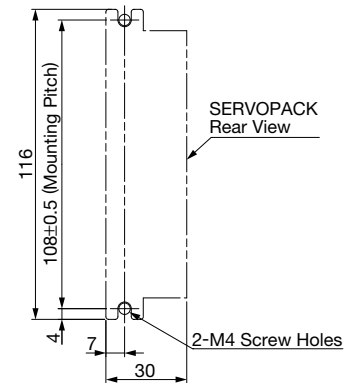
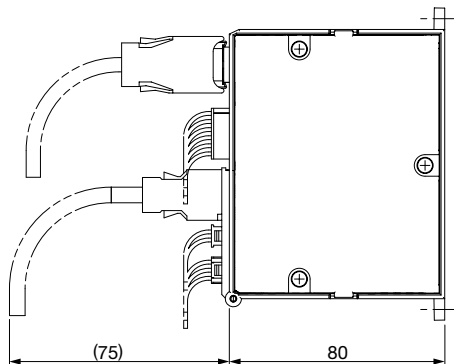
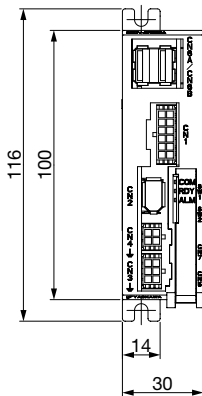

Mounting Hole Diagram

Approx. Mass: 0.3 kg

(3) MECHATROLINK-III Communications Reference, Model: SGDV-1R7E21A, -2R9E21A

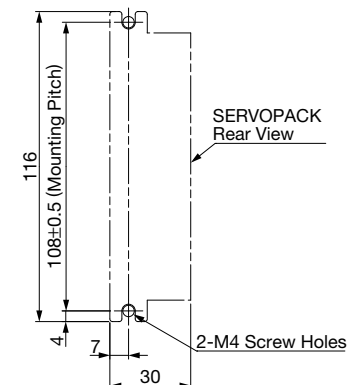
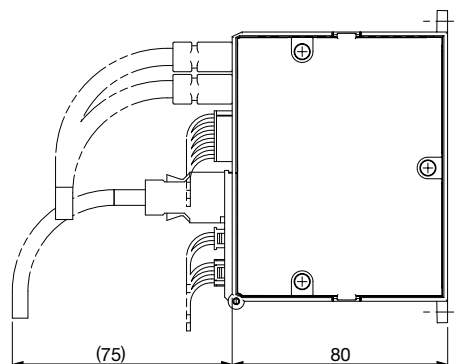
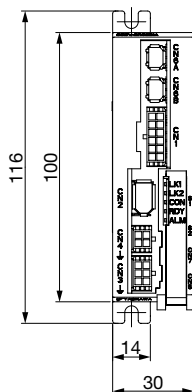

Mounting Hole Diagram

Approx. Mass: 0.3 kg

**Cover Dimensions and Connectors**

(1) Analog Voltage Reference /Pulse Train Reference

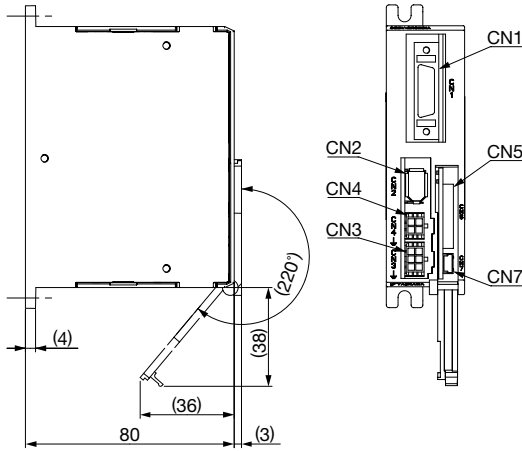

Port	Model	Pin	Manufacturer
CN1	10226-52A2PL	26	Sumitomo 3M Ltd.
CN2	3E106-0220KV	6	Sumitomo 3M Ltd.
CN3	43045-0600	6	Molex Japan Co., Ltd.
CN4	43045-0400	4	Molex Japan Co., Ltd.
CN5	DA3R018HB1	18	Japan Aviation Electronics Industry, Ltd.
CN7	UX60SC-MB-5S8□80□	5	Hirose Electric Corporation.

Note: The connectors above or their equivalents are used for SERVOPACKs.

(2) MECHATROLINK-II Communications Reference

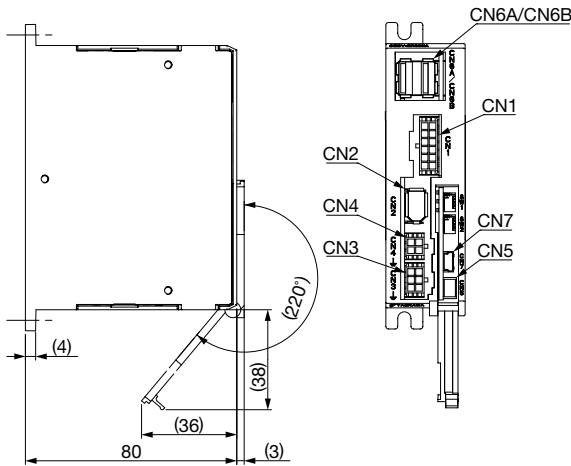

Port	Model	Pin	Manufacturer
CN1	43045-1201	12	Molex Japan Co., Ltd.
CN2	3E106-0220KV	6	Sumitomo 3M Ltd.
CN3	43045-0600	6	Molex Japan Co., Ltd.
CN4	43045-0400	4	Molex Japan Co., Ltd.
CN5	DF11-6DP-2DS□52□	6	Hirose Electric Corporation.
CN6A/ CN6B	1903815-1	8	Tyco Electronics Japan G.K.
CN7	UX60SC-MB-5S8□80□	5	Hirose Electric Corporation.

Note: The connectors above or their equivalents are used for SERVOPACKs.

(3) MECHATROLINK-III Communications Reference

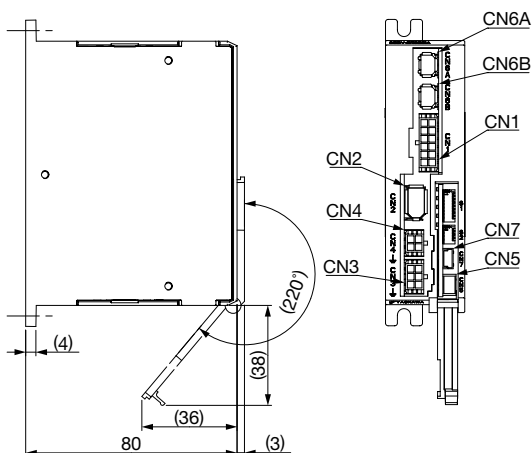

Port	Model	Pin	Manufacturer
CN1	43045-1201	12	Molex Japan Co., Ltd.
CN2	3E106-0220KV	6	Sumitomo 3M Ltd.
CN3	43045-0600	6	Molex Japan Co., Ltd.
CN4	43045-0400	4	Molex Japan Co., Ltd.
CN5	DF11-6DP-2DS□52□	6	Hirose Electric Corporation.
CN6A/ CN6B	1981386-1	8	Tyco Electronics Japan G.K.
CN7	UX60SC-MB-5S8□80□	5	Hirose Electric Corporation.

Note: The connectors above or their equivalents are used for SERVOPACKs.

DC

SERVOPACK External Dimensions





# Wiring Main Circuit and Peripheral Devices

## Wiring Main Circuit

### Typical Main Circuit Wiring Examples

This section shows an example of the typical wiring for the main circuit.



**WARNING**

High voltage may still remain in the SERVOPACK after the power has been turned OFF. To avoid electric shocks, do not touch the power supply terminals. Be sure that the remaining voltage has been discharged before wiring and inspecting.

#### IMPORTANT

- Turn ON the power supplies for the control and for the main circuit at the same time, or first turn ON the control power and then the power for the main circuit power. When turning OFF the power, first turn OFF the power for the main circuit and then control power.
- Use separate power supplies for the main circuit AC/DC power supply and control AC/DC power supply. Use power supplies with double or reinforced insulation and that have also been certified for safety standards.
- Do not connect the following devices to the control power line: motors, solenoids, or other devices with large load fluctuations, and contactors or other devices that generate surge voltage. If connected, internal elements may deteriorate or a fuse may melt.

### SERVOPACKs with Analog Voltage Reference/Pulse Train Reference

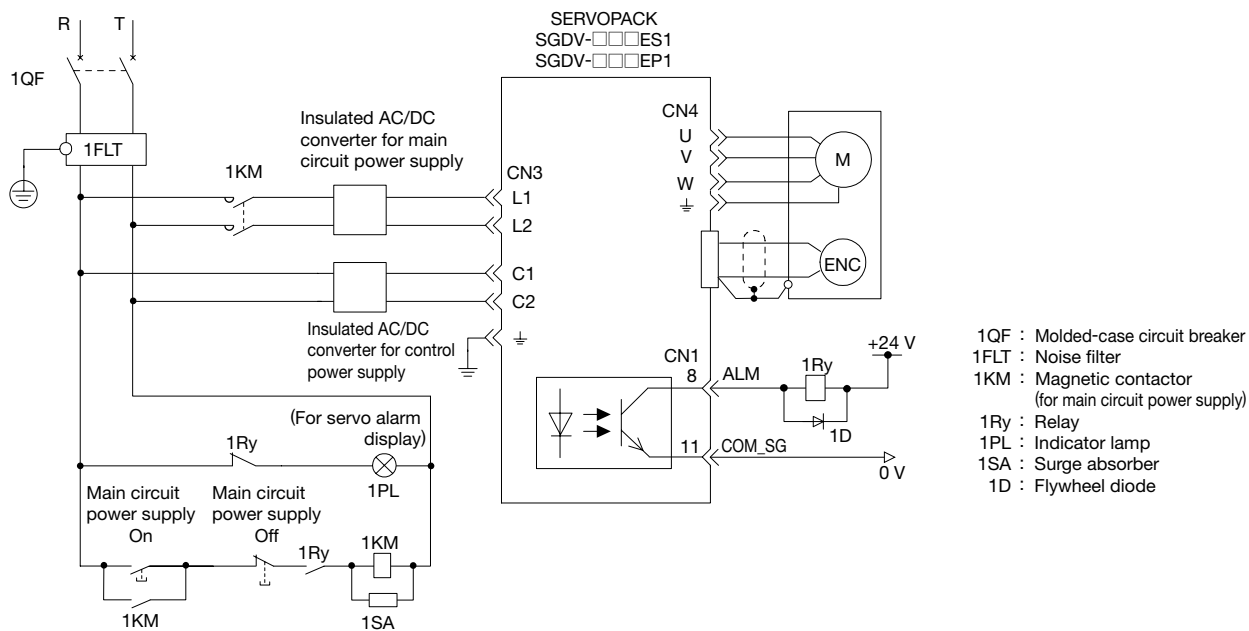

## Wiring Main Circuit

● SERVOPACKs with MECHATROLINK-II or -III Communications Reference

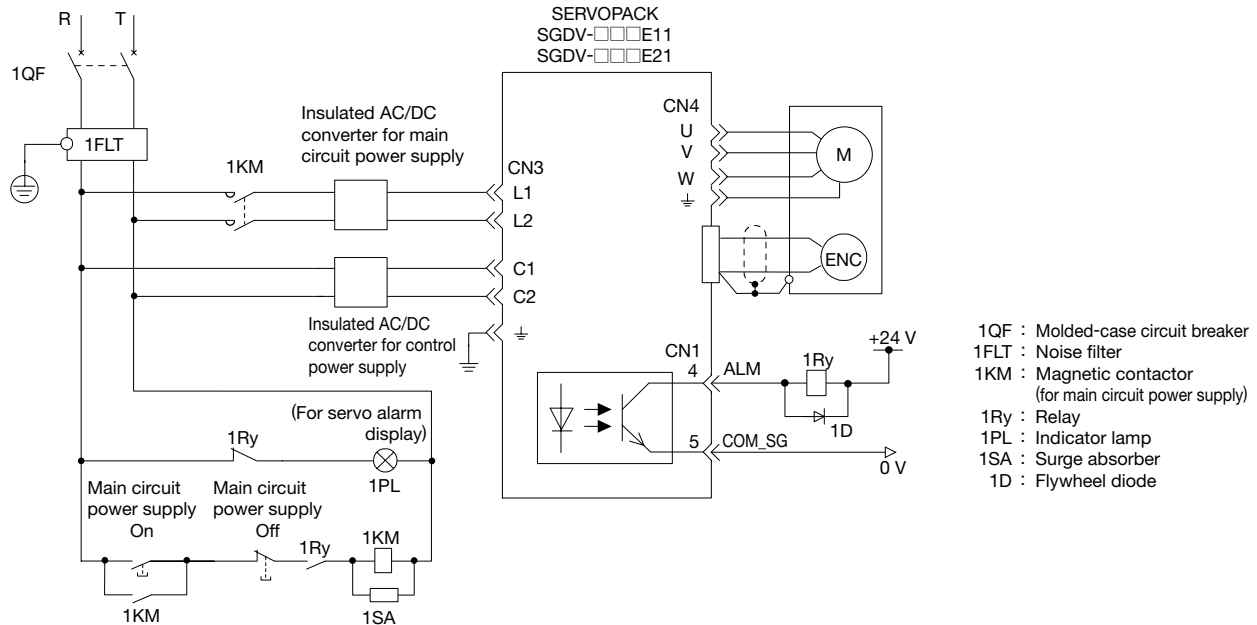

● General Precautions for Wiring

**IMPORTANT**

- Use a molded-case circuit breaker (1QF) or a fuse to protect the servo system.  
 Always use a molded-case circuit breaker or a fuse to protect the servo system from accidents involving different power voltages or other accidents.
- Install a ground fault detector.  
 The SERVOPACK does not have a built-in protective circuit for grounding. For a safer system, install a ground fault detector to protect against overloads and short circuits, or install a ground fault detector that is combined with a molded-case circuit breaker.
- Do not turn the power OFF and ON more than necessary.
- Do not use the SERVOPACK for applications that require the power to be frequently turned OFF and ON. Such applications will cause elements in the SERVOPACK to deteriorate.
- As a guideline, wait at least one hour before restarting the power after turning OFF the power during operation.

To ensure safe, stable application of the servo system, observe the following precautions when wiring.

Observe the following precautions when wiring the main circuit.

- Use shielded twisted-pair wires or shielded, multi-core, twisted-pair wires for I/O signal cables and the encoder cables.
- The maximum wiring length is 3 m for I/O signal cables, 50 m for encoder cables or servomotor main circuit cables, and 10 m for control power and main circuit power cables.

Observe the following precautions when grounding.

- Use a cable that is as thick as possible.
- Ground the SERVOPACK to a resistance of 100 Ω or less.
- Be sure to ground at only one point.
- Ground the servomotor directly if the servomotor is insulated from the machine.

The signal cable conductors are as thin as 0.2 mm<sup>2</sup> or 0.3 mm<sup>2</sup>. Do not impose excessive bending force or tension.

## Wiring Main Circuit

### ● Precautions When Using More Than One SERVOPACK

This section shows an example of wiring and precautions when more than one SERVOPACK is used.

#### ● Wiring Example

Wire the circuit so that each alarm detection relay (1 Ry, 2 Ry, 3 Ry) can be separately activated to issue an alarm.

After a SERVOPACK alarm is activated, the ALM output signal transistor is turned OFF.

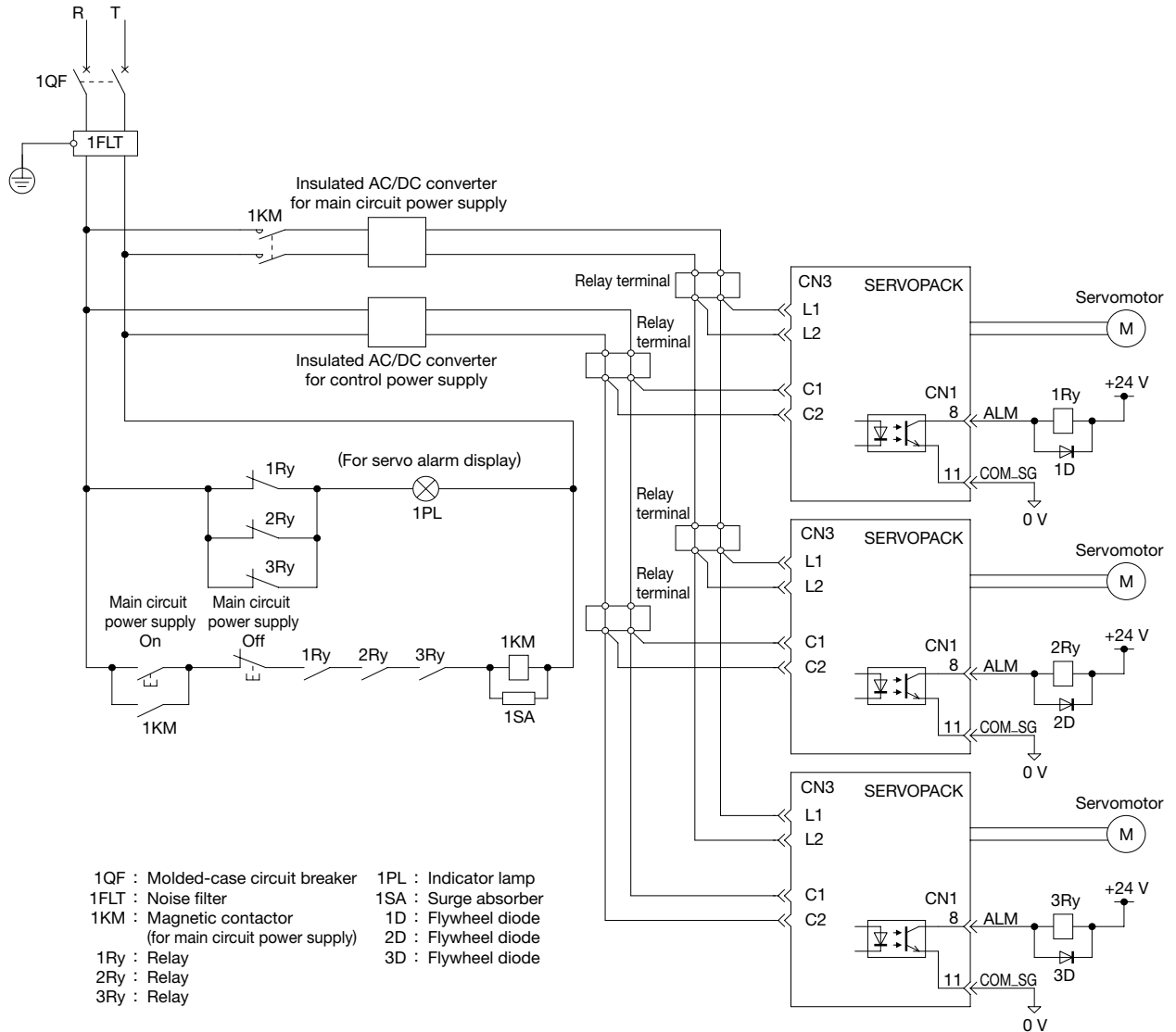

#### ● Precautions

- Multiple SERVOPACKs can share a single molded-case circuit breaker (1QF) and a single noise filter. Always select a molded-case circuit breaker and a noise filter that have a large enough capacity to handle all SERVOPACKs used. When selecting a breaker and a filter, also consider load conditions.
- When using SERVOPACKs with DC power, four signals for the sequencing of one SERVOPACK are connected at only one location (COM\_SG) for common signal grounding. If alarm signals for multiple SERVOPACKs are connected in series, an alarm signal may not be received correctly when an alarm is issued.

**SERVOPACK Main Circuit Wire**

● For 48 VDC and 24 VDC

Cables	Terminal Symbol	SERVOPACK Model SGD V-		Remarks
		1R7E	2R9E	
Power Supply Cable	L1, L2, C1, C2, $\pm$	JZSP-CF1G00-□□-E		For details, refer to Selecting Cables for SERVOPACKs with DC Power Input on page 13.
Servomotor Main Circuit Cable	U, V, W, $\pm$	JZSP-CF1M00-□□-E (For motors without brakes) JZSP-CF1M10-□□-E (For motors with brakes) JZSP-CF1M20-□□-E (Flexible type cable for motors without brakes) JZSP-CF1M30-□□-E (Flexible type cable for motors with brakes)		For details, refer to Selecting Cables on page 415, page 425, and page 435.

If assembling a main circuit cable for the SERVOPACK, observe the following conditions.

**IMPORTANT**

- The specified wire sizes are for use when the three lead cables are bundled and when the rated electric current is applied with a surrounding air temperature of 40°C
- Use a wire with a minimum withstand voltage of 100 V.
- Use insulated wire with an outer diameter of 1.85 mm or smaller. The wire size is restricted due to the specifications of the contact used.
- If cables are bundled in PVC pipes or metal ducts, remember to consider resulting reduction of the allowable current.
- Use heat-resistant wire for high surrounding air or panel temperatures.
- Use a cable with a maximum length of 10 m for the main circuit's power and one with a maximum length of 50 m for the motor's main circuit.

Cables	SERVOPACK Model SGD V-		Remarks
	1R7E	2R9E	
CN3 For Main Circuit Power	Connector	43025-0600 (by Molex Japan Co., Ltd.)	6 poles
	Contact	43030-0001 (by Molex Japan Co., Ltd.)	-
	Wire for Main Circuit Power (L1, L2, $\pm$ )	UL1007, AWG20	Rated voltage: 300 V; rated temperature: 80°C
	Wire for Control Power (C1, C2, $\pm$ )	UL1007, AWG20-24	Rated voltage: 300 V; rated temperature: 80°C
CN4 For Motor Main Circuit	Connector (SERVOPACK End)	43025-0400 (by Molex Japan Co., Ltd.)	4 poles
	Contact (SERVOPACK End)	43030-0001 (by Molex Japan Co., Ltd.)	-
	Connector (for a servomotor without brake)	43020-0401 (by Molex Japan Co., Ltd.)	4 poles
	Connector (for a servomotor with brake)	43020-0601 (by Molex Japan Co., Ltd.)	6 poles
	Contact (Servomotor End)	43031-0001 (by Molex Japan Co., Ltd.)	-
	Wire for Servomotor Main Circuit (U, V, W, brake power, $\pm$ )	UL1007, AWG20	Rated voltage: 300 V; rated temperature: 80°C

DC

## Molded-case Circuit Breaker and Fuse Capacity

### ● Input Power Capacity

Main Circuit Power Supply	Applicable Servomotor Max. Capacity W	SERVOPACK Model SGD V-	Main Circuit Power Supply Capacity per SERVOPACK W	Input Current Capacity		
				Main Circuit Continuous Rated Current A	Main Circuit Instantaneous Maximum Current A	Control Circuit A
24 VDC	11	1R7E	108	2.0	5.5	0.3
	30	2R9E	165	3.5	8.5	
48 VDC	11	1R7E	169	1.0	4.5	
	30	2R9E	411	2.0	10.5	

Note: The power supply capacities indicated in the table are values at an instantaneous maximum load. The main circuit's power supply capacity and the input current capacity are indicated in net values.

### ● Molded-case Circuit Breaker and Fuse Capacity

Power Supply	Output Voltage	SERVOPACK Model SGD V-	Current Capacity of MCCB or Fuse (Main + Control Circuit)	
			Power Supply Voltage at 100 VAC Arms	Power Supply Voltage at 200 VAC Arms
Main Circuit Power Supply	24 VDC	1R7E	5.5	2.9
	48 VDC		9.0	4.8
Control Circuit Power Supply	24 VDC	2R9E	–	–

Note: Select an MCCB or a fuse that satisfies the following braking characteristics.  
 •No braking at the inrush current value of the used power supply for 20 ms.

### ● AC/DC Power Supply

Use an AC/DC power supply that is appropriate for the voltage of the main circuit and the model of the SERVOPACK and servomotor. The recommended AC/DC power supplies are shown in the following table.

Main Circuit Power Supply	SERVOPACK Model	Servomotor Model	Recommended AC/DC Power Supply*	
			Model	Manufacturer
24 VDC	SGDV-1R7E□1A	SGMMV-B3E2A□□	HWS150-24	TDK-Lambda Corp.
		SGMMV-B5E2A□□		
		SGMMV-B9E2A□□		
	SGDV-2R9E□1A	SGMMV-A1E2A□□	HWS300-24	
		SGMMV-A2E2A□□		
		SGMMV-A3E2A□□		
48 VDC	SGDV-1R7E□1A	SGMMV-B3E2A□□	HWS300-48	
		SGMMV-B5E2A□□		
		SGMMV-B9E2A□□		
	SGDV-2R9E□1A	SGMMV-A1E2A□□	HWS300P-48	
		SGMMV-A2E2A□□		
		SGMMV-A3E2A□□		

\*: Use double-insulated power supplies certified for the following international safety standards: UL60950 or EN60950.

## Noise Filters

### ● Noise Filter Selection

Use of the following noise filter is recommended for the AC side.

Power Supply AC Side Voltage	SERVOPACK Model SGDV-	Recommended Noise Filter		
		Model	Specifications	Leakage Current
100 VAC/ 200 VAC	1R7E, 2R9E	FN2070-6/07	Single-phase 250V 6A	0.734 mA 230 VAC/50 Hz

Note: RoHS-compliant models are not available. Contact the manufacturers when in need of an RoHS-compliant model.

#### IMPORTANT

Some noise filters have large amounts of leakage current. The grounding measures taken also affect the extent of the leakage current. If necessary, select an appropriate leakage current detector or leakage current breaker taking into account the grounding measures that are used and leakage current from the noise filter. Contact the manufacturer of the noise filter for details.

### ● External Dimensions (Units: mm)

FN Type (by Schaffner EMC, Inc.)

Model	FN2070-6/07
Dimensional Drawings	<div style="display: flex; justify-content: space-around;"> <div style="text-align: center;"> <p>Top View</p> </div> <div style="text-align: center;"> <p>Side View</p> </div> </div>
	<p>Connection Lead P/N/E</p>

# Magnetic Contactors

## ● Magnetic Contactor Selection

A magnetic contactor is required when external sequence circuit is used to turn the power of a SERVOPACK OFF and ON. The magnetic contactor shown in the following table is recommended on the AC side of the main circuit's power supply. Be sure to attach a surge absorber (surge absorber unit etc.) to the excitation coil of the magnetic contactor.

Power Supply AC Side Voltage	SERVOPACK Model SGDV-	Magnetic Contactor	
		Model	Specifications
100 VAC/ 200 VAC	1R7E, 2R9E	SC-03	(RoHS)

Note: Contact Fuji Electric FA Components & Systems Co., Ltd.

## ● External Dimensions (Units: mm)

### • SC-03

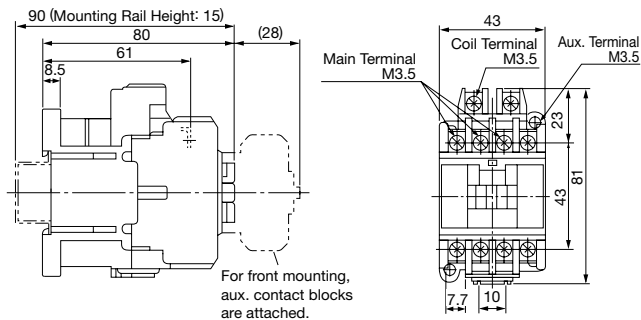

### Mounting Hole Dimensions

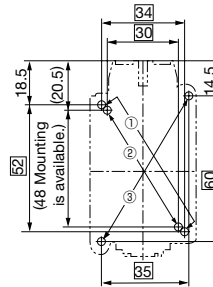

Aux. Contact	Structure
1a	
1b	

● Mounting methods: The following methods 1, 2, 3 are available.





- 1...34 × 48 to 52
- 2...30 × 48
- 3...35 × 60

● Mounting screw: 2-M4

Use the two mounting holes on the diagonal line to mount a contactor.

Approx. Mass : 0.32 kg

## Others

<b>Selecting Servomotor Capacity and Regenerative Capacity</b>	<b>450</b>	
Servomotor Capacity Selection Examples		
Selecting Regenerative Resistors		
<b>Connection to Host Controller</b>	<b>466</b>	
Example of Connection to Machine Controller MP2□□□		
Example of Connection to SVA-01 Motion Module for MP2200/MP2300		
Example of Connection to OMRON's Motion Control Unit		
Example of Connection to OMRON's Position Control Unit		
Example of Connection to Mitsubishi's QD75D□ Positioning Unit (SERVOPACK in Position Control)		
<b>International Standards</b>	<b>471</b>	
<b>Warranty</b>	<b>472</b>	





# Selecting Servomotor Capacity and Regenerative Capacity

## Servomotor Capacity Selection Examples

Use the AC servo drive capacity selection program SigmaJunmaSize+ to select servomotor capacity. The program can be downloaded for free from our web site (<http://www.e-mechatronics.com/>).

### ● Selection Example for Speed Control

#### Mechanical Specifications

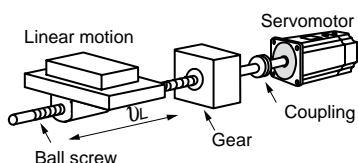

- Load speed:  $v_L = 15$  m/min
- Linear motion section mass:  $m = 250$  kg
- Ball screw length:  $\ell_B = 1.0$  m
- Ball screw diameter:  $d_B = 0.02$  m
- Ball screw lead:  $P_B = 0.01$  m
- Ball screw material density:  $\rho = 7.87 \times 10^3$  kg/m<sup>3</sup>
- Gear ratio:  $1/2$  ( $R = 2$ )

- Gear + coupling moment of inertia :  $J_G = 0.40 \times 10^{-4}$  kg·m<sup>2</sup>
- Feeding times:  $n = 40$  times/min
- Feeding distance:  $\ell = 0.275$  m
- Feeding time:  $tm = 1.2$  s max.
- Friction coefficient:  $\mu = 0.2$
- Mechanical efficiency:  $\eta = 0.9$  (90%)

#### (1) Speed Diagram

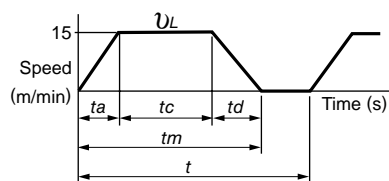

$$t = \frac{60}{n} = \frac{60}{40} = 1.5 \text{ (s)}$$

where  $t_a = t_d$

$$t_a = tm - \frac{60\ell}{v_L} = 1.2 - \frac{60 \times 0.275}{15} = 1.2 - 1.1 = 0.1 \text{ (s)}$$

$$t_c = 1.2 - 0.1 \times 2 = 1.0 \text{ (s)}$$

#### (2) Rotation Speed

· Load axis rotation speed  $n_L = \frac{v_L}{P_B} = \frac{15}{0.01} = 1500 \text{ (min}^{-1}\text{)}$

· Motor shaft rotation speed Gear ratio  $1/R = 1/2$  ( $R=2$ )  
Therefore,  $n_M = n_L \cdot R = 1500 \times 2 = 3000 \text{ (min}^{-1}\text{)}$

#### (3) Load torque

$$T_L = \frac{9.8\mu \cdot m \cdot P_B}{2\pi R \cdot \eta} = \frac{9.8 \times 0.2 \times 250 \times 0.01}{2\pi \times 2 \times 0.9} = 0.43 \text{ (N} \cdot \text{m)}$$

#### (4) Load Moment of Inertia

· Linear motion section  $J_{L1} = m \left( \frac{P_B}{2\pi R} \right)^2 = 250 \times \left( \frac{0.01}{2\pi \times 2} \right)^2 = 1.58 \times 10^{-4} \text{ (kg} \cdot \text{m}^2\text{)}$

· Ball screw  $J_B = \frac{\pi}{32} \rho \cdot \ell_B \cdot d_B^4 \cdot \frac{1}{R^2} = \frac{\pi}{32} \times 7.87 \times 10^3 \times 1.0 \times (0.02)^4 \cdot \frac{1}{2^2} = 0.31 \times 10^{-4} \text{ (kg} \cdot \text{m}^2\text{)}$

· Coupling  $J_G = 0.40 \times 10^{-4} \text{ (kg} \cdot \text{m}^2\text{)}$

· Load moment of inertia at motor shaft  $J_L = J_{L1} + J_B + J_G = (1.58 + 0.31 + 0.40) \times 10^{-4} = 2.29 \times 10^{-4} \text{ (kg} \cdot \text{m}^2\text{)}$

#### (5) Load Moving Power

$$P_O = \frac{2\pi n_M \cdot T_L}{60} = \frac{2\pi \times 3000 \times 0.43}{60} = 135 \text{ (W)}$$

## Servomotor Capacity Selection Examples

### (6) Load Acceleration Power

$$P_a = \left( \frac{2\pi}{60} n_M \right)^2 \frac{J_L}{ta} = \left( \frac{2\pi}{60} \times 3000 \right)^2 \times \frac{2.29 \times 10^{-4}}{0.1} = 226 \text{ (W)}$$

### (7) Servomotor Provisional Selection

- (a) Selecting Conditions
- $T_L \leq$  Motor rated torque
  - $\frac{(P_o + P_a)}{2} <$  Provisionally selected servomotor rated output  $< (P_o + P_a)$
  - $n_M \leq$  Motor rated speed
  - $J_L \leq$  Allowable load moment of inertia

The followings satisfy the conditions.

· Servomotor SGMJV-02A

### (b) Specifications of the Provisionally Selected Servomotor

- Rated output : 200 (W)
- Rated motor speed : 3000 ( $\text{min}^{-1}$ )
- Rated torque : 0.637 ( $\text{N}\cdot\text{m}$ )
- Instantaneous peak torque : 2.23 ( $\text{N}\cdot\text{m}$ )
- Servomotor moment of inertia :  $0.259 \times 10^{-4}$  ( $\text{kg}\cdot\text{m}^2$ )
- Allowable load moment of inertia :  $0.259 \times 10^{-4} \times 15 = 3.885 \times 10^{-4}$  ( $\text{kg}\cdot\text{m}^2$ )

### (8) Verification on the Provisionally Selected Servomotor

$$\begin{aligned} \cdot \text{Required acceleration torque: } T_P &= \frac{2\pi n_M (J_M + J_L)}{60ta} + T_L = \frac{2\pi \times 3000 \times (0.259 + 2.29) \times 10^{-4}}{60 \times 0.1} + 0.43 \\ &\cong 1.23 \text{ (N}\cdot\text{m)} < \text{Instantaneous peak torque} \dots \text{Satisfactory} \end{aligned}$$

$$\begin{aligned} \cdot \text{Required deceleration torque: } T_S &= \frac{2\pi n_M (J_M + J_L)}{60td} - T_L = \frac{2\pi \times 3000 \times (0.259 + 2.29) \times 10^{-4}}{60 \times 0.1} - 0.43 \\ &\cong 0.37 \text{ (N}\cdot\text{m)} < \text{Instantaneous peak torque} \dots \text{Satisfactory} \end{aligned}$$

$$\begin{aligned} \cdot \text{Torque effective value: } T_{rms} &= \sqrt{\frac{T_P^2 \cdot ta + T_L^2 \cdot tc + T_S^2 \cdot td}{t}} = \sqrt{\frac{(1.23)^2 \times 0.1 + (0.43)^2 \times 1.0 + (0.37)^2 \times 0.1}{1.5}} \\ &\cong 0.483 \text{ (N}\cdot\text{m)} < \text{Rated torque} \dots \text{Satisfactory} \end{aligned}$$

### (9) Result

The provisionally selected servomotor is confirmed to be applicable.

The torque diagram is shown below.

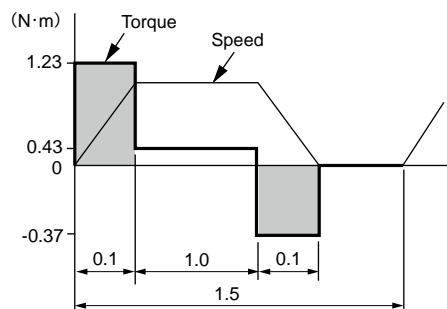

## Servomotor Capacity Selection Examples

Use the AC servo drive capacity selection program SigmaJunmaSize+ to select servomotor capacity.  
The program can be downloaded for free from our web site (<http://www.e-mechatronics.com/>).

### ● Selection Example for Position Control

#### Mechanical Specifications

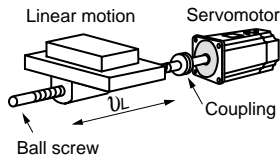

- Load speed:  $v_L = 15$  m/min
- Linear motion section mass:  $m = 80$  kg
- Ball screw length:  $l_B = 0.8$  m
- Ball screw diameter:  $d_B = 0.016$  m
- Ball screw lead:  $P_B = 0.005$  m
- Ball screw material density:  $\rho = 7.87 \times 10^3$  kg/m<sup>3</sup>
- Coupling mass:  $mc = 0.3$  kg
- Coupling outer diameter:  $dc = 0.03$  m
- Positioning times:  $n = 40$  times/min
- Positioning distance:  $l = 0.25$  m
- Positioning time:  $tm = 1.2$  s max.
- Electrical stop accuracy:  $\delta = \pm 0.01$  mm
- Friction coefficient:  $\mu = 0.2$
- Mechanical efficiency:  $\eta = 0.9$  (90%)

#### (1) Speed Diagram

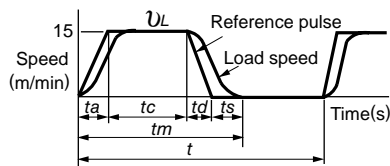

$$t = \frac{60}{n} = \frac{60}{40} = 1.5(\text{s})$$

$$\text{Where } t_a = t_d, t_s = 0.1(\text{s})$$

$$t_a = tm - t_s - \frac{60l}{v_L} = 1.2 - 0.1 - \frac{60 \times 0.25}{15} = 0.1(\text{s})$$

$$t_c = 1.2 - 0.1 \times 2 = 1.0(\text{s})$$

#### (2) Rotation Speed

$$\cdot \text{Load axis rotation speed } n_L = \frac{v_L}{P_B} = \frac{15}{0.005} = 3000(\text{min}^{-1})$$

· Motor shaft rotation speed with direct coupling: Gear ratio  $1/R = 1/1$

$$\text{Therefore, } n_M = n_L \cdot R = 3000 \times 1 = 3000 (\text{min}^{-1})$$

#### (3) Load Torque

$$T_L = \frac{9.8\mu \cdot m \cdot P_B}{2\pi R \cdot \eta} = \frac{9.8 \times 0.2 \times 80 \times 0.005}{2\pi \times 1 \times 0.9} = 0.139(\text{N}\cdot\text{m})$$

#### (4) Load Moment of Inertia

$$\cdot \text{Liner motion section } J_{L1} = m \left( \frac{P_B}{2\pi R} \right)^2 = 80 \times \left( \frac{0.005}{2\pi \times 1} \right)^2 = 0.507 \times 10^{-4}(\text{kg}\cdot\text{m}^2)$$

$$\cdot \text{Ball screw } J_B = \frac{\pi}{32} \rho \cdot l_B \cdot d_B^4 = \frac{\pi}{32} \times 7.87 \times 10^3 \times 0.8 \times (0.016)^4 = 0.405 \times 10^{-4}(\text{kg}\cdot\text{m}^2)$$

$$\cdot \text{Coupling } J_C = \frac{1}{8} mc \cdot dc^4 = \frac{1}{8} \times 0.3 \times (0.03)^2 = 0.338 \times 10^{-4}(\text{kg}\cdot\text{m}^2)$$

· Load moment of inertia at the motor shaft

$$J_L = J_{L1} + J_B + J_C = 1.25 \times 10^{-4} (\text{kg} \cdot \text{m}^2)$$

## Servomotor Capacity Selection Examples

### (5) Load Moving Power

$$P_o = \frac{2\pi n_M \cdot T_L}{60} = \frac{2\pi \times 3000 \times 0.139}{60} = 43.7(\text{W})$$

### (6) Load Acceleration Power

$$P_a = \left( \frac{2\pi}{60} n_M \right)^2 \frac{J_L}{ta} = \left( \frac{2\pi}{60} \times 3000 \right)^2 \times \frac{1.25 \times 10^{-4}}{0.1} = 123.4(\text{W})$$

### (7) Provisionally Servomotor Selection

(a) Selecting Conditions      ·  $T_L \leq$  Motor rated torque

$$\cdot \frac{(P_o + P_a)}{2} < \text{Provisionally selected servomotor rated output} < (P_o + P_a)$$

·  $n_M \leq$  Motor rated speed

·  $J_L \leq$  Allowable load moment of inertia

The followings satisfy the conditions.

· Servomotor SGMJV-01A

### (b) Specifications of Servomotor

· Rated output	: 100 (W)
· Rated motor speed	: 3000 (min <sup>-1</sup> )
· Rated torque	: 0.318 (N·m)
· Instantaneous peak torque	: 1.11 (N·m)
· Servomotor rotor moment of inertia	: $0.0665 \times 10^{-4}$ (kg·m <sup>2</sup> )
· Allowable load moment of inertia	: $0.0665 \times 10^{-4} \times 20 = 1.33 \times 10^{-4}$ (kg·m <sup>2</sup> )
· Encoder resolution	: 20 bit (1048576P/rev)

### (8) Verification on Provisionally Selected Servomotor

$$\begin{aligned} \cdot \text{Required acceleration torque: } T_P &= \frac{2\pi n_M (J_M + J_L)}{60ta} + T_L = \frac{2\pi \times 3000 \times (0.0665 + 1.25) \times 10^{-4}}{60 \times 0.1} + 0.139 \\ &\cong 0.552 \text{ (N·m)} < \text{Instantaneous peak torque} \dots \text{Satisfactory} \end{aligned}$$

$$\begin{aligned} \cdot \text{Required deceleration torque: } T_S &= \frac{2\pi n_M (J_M + J_L)}{60td} - T_L = \frac{2\pi \times 3000 \times (0.0665 + 1.25) \times 10^{-4}}{60 \times 0.1} - 0.139 \\ &\cong 0.275 \text{ (N·m)} < \text{Instantaneous peak torque} \dots \text{Satisfactory} \end{aligned}$$

$$\begin{aligned} \cdot \text{Torque effective value: } T_{rms} &= \sqrt{\frac{T_P^2 \cdot ta + T_L^2 \cdot tc + T_S^2 \cdot td}{t}} = \sqrt{\frac{(0.552)^2 \times 0.1 + (0.139)^2 \times 0.9 + (0.275)^2 \times 0.1}{1.5}} \\ &\cong 0.192 \text{ (N·m)} < \text{Rated torque} \dots \text{Satisfactory} \end{aligned}$$

The above confirms that the provisionally selected servomotor is sufficient. In the next step, their performance in position control are checked.

## Servomotor Capacity Selection Examples

(9) PG Feedback Pulse Dividing Ratio: Setting of Electronic Gear Ratio

$$\left(\frac{B}{A}\right)$$

As the electrical stop accuracy  $\delta = \pm 0.01\text{mm}$ , take the position detection unit  $\Delta\ell = 0.01\text{mm/pulse}$ .

$$\frac{P_B}{\Delta\ell} \times \left(\frac{B}{A}\right) = \frac{5}{0.01} \times \left(\frac{B}{A}\right) = 1048576$$

$$k = \left(\frac{B}{A}\right) = \frac{1048576}{500}$$

(10) Reference Pulse Frequency

$$v_s = \frac{1000v_L}{60 \times \Delta\ell} = \frac{1000 \times 15}{60 \times 0.01} = 25,000(\text{pps})$$

(11) Error Counter Pulses

Position loop gain  $K_P = 40$  (1/s)

$$\varepsilon = \frac{v_s}{K_P} = \frac{25,000}{40} = 625(\text{pulse})$$

(12) Electrical Stop Accuracy

$$\pm \Delta\varepsilon = \pm \frac{\varepsilon}{(\text{SERVOPACK control range}) \times \frac{n_M}{n_R}} = \pm \frac{625}{5000 \times \frac{3000}{3000}} = \pm 0.125 < \pm 1(\text{pulse}) = \pm 0.01(\text{mm})$$

The above results confirm that the selected servomotor is applicable for the position control.

## Selecting Regenerative Resistors

### (1) Simple Calculation

When driving a servomotor with the horizontal axis, check the external regenerative resistor requirements using the calculation method shown below.

#### (a) SGD V-□□□F, -R70A, -R90A, -1R6A, and -2R8A SERVOPACKs

These SERVOPACKs do not have built-in regenerative resistors. The energy that can be charged with capacitors is shown in the following table. If the rotational energy in the servomotor exceeds these values, then connect an external regenerative resistor.

Voltage	Applicable SERVOPACK	Regenerative Energy that Can be Processed (joules)	Remarks
Single-phase 100 V	SGDV-R70F, R90F, 2R1F	26.4	Value when main circuit input voltage is 100 VAC
	SGDV-2R8F	44.1	
Three-phase 200V	SGDV-R70A, -R90A, -1R6A	24.2	Value when main circuit input voltage is 200 VAC
	SGDV-2R8A	31.7	

Calculate the rotational energy ( $E_s$ ) in the servomotor from the following equation:

$$E_s = J \times (nM)^2 / 182 \text{ (joules)}$$

$$J = J_M + J_L$$

- $J_M$ : Servomotor rotor moment of inertia (kg·m<sup>2</sup>)
- $J_L$ : Load converted to shaft moment of inertia (kg·m<sup>2</sup>)
- $nM$ : Rotation speed used by servomotor (min<sup>-1</sup>)

#### (b) SERVOPACKs other than (a)

SERVOPACKs other than SGD V-□□□F, -R70A, -R90A, -1R6A, and -2R8A have built-in regenerative resistors. The allowable frequencies for just the servomotor in acceleration and deceleration operation, during the rotation speed cycle from 0 (min<sup>-1</sup>) to the maximum rotation speed to 0, are summarized in the following table.

Convert the data into the values obtained with actual rotation speed and load moment of inertia to determine whether an external regenerative resistor is needed.

Voltage	Servomotor Model	Allowable Frequencies in Regenerative Mode (time/min)													
		03	05	06	08	09	10	13	15	20	25	30	40	44	50
Three-phase 200 V	SGMJV-□□	-	-	-	15	-	-	-	-	-	-	-	-	-	-
	SGMAV-□□	-	-	74	31	-	20	-	-	-	-	-	-	-	-
	SGMPS-□□	-	-	-	11	-	-	-	7	-	-	-	-	-	-
	SGMGV-□□A	39	29	-	-	6	-	6	-	7	-	9*	-	6	-
	SGMSV-□□A	-	-	-	-	-	13	-	21	28	21	10	16	-	12
Three-phase 400V	SGMGV-□□D	68	51	-	-	10	-	8	-	13	-	7	-	6	-
	SGMSV-□□D	-	-	-	-	-	24	-	30	49	38	17	16	-	12

\*: This value is "4," when used in combination with SGD V-200A SERVOPACK.

## Selecting Regenerative Resistors

### Operating Conditions for Allowable Regenerative Frequency Calculation

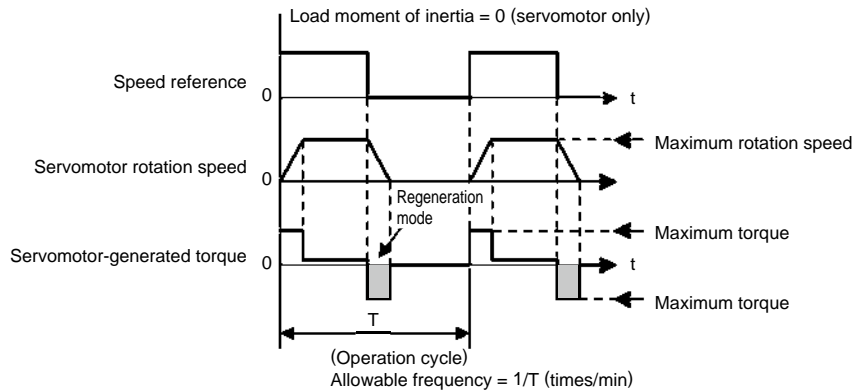

Use the following equation to calculate the allowable frequency for regeneration mode operation

$$\text{Allowable frequency} = \frac{\text{Allowable frequency for Servomotor only}}{(1+n)} \times \left( \frac{\text{Max. rotation speed}}{\text{Rotation speed}} \right)^2 (\text{time/min})$$

$$\cdot n = J_L / J_M$$

·  $J_M$ : Servomotor rotor moment of inertia ( $\text{kg}\cdot\text{m}^2$ )

·  $J_L$ : Load converted to shaft moment of inertia ( $\text{kg}\cdot\text{m}^2$ )

#### (c) SGD V-470A, -550A, -590A, -780A SERVOPACKs

These SERVOPACKs do not have built-in regenerative resistors. The following table shows the allowable regenerative frequencies when the JUSP-RA04-E or JUSP-RA05-E regenerative resistor is used together with an applicable SERVOPACK.

The servomotor driving conditions and the conversion equation for the allowable regenerative frequencies to the rotation speed and load moment of inertia are the same as that shown in (b) on the previous page.

Voltage	Servomotor Model	Allowable Frequencies in Regenerative Mode (time/min)				
		55	70	75	1A	1E
Three-phase 200 V	SGMGV-□□A	24	—	34	39	31
	SGMSV-□□A	—	124	—	—	—

## Selecting Regenerative Resistors

### (2) Calculating the Regenerative Energy

This section shows the procedure for calculating the regenerative resistor capacity when acceleration and deceleration operation is as shown in the following diagram

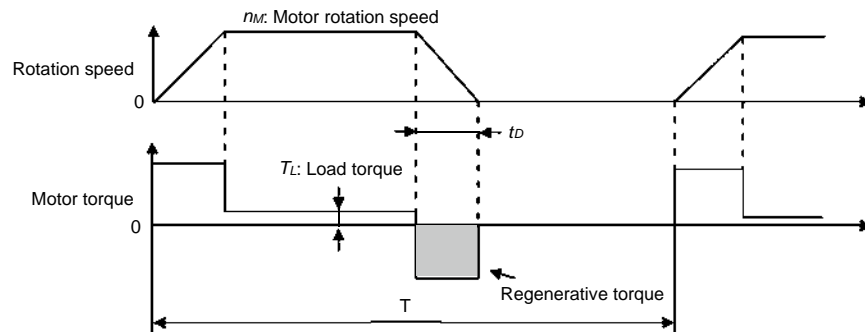

#### ● Calculation Procedure

The procedure for calculating the regenerative capacity is as follows:

Step	Item	Symbol	Equation
1	Calculate the rotational energy of the servomotor.	$E_s$	$E_s = JnM^2 / 182$
2	Calculate the energy consumed by load loss during the deceleration period	$E_L$	$E_L = (\pi / 60)nMT_L t_d$
3	Calculate the energy lost from servomotor winding resistance.	$E_M$	(Value calculated from (4) Servomotor Winding Resistance Loss diagrams) $\times t_d$
4	Calculate the SERVOPACK energy that can be absorbed.	$E_C$	Calculate from (3) SERVOPACK's Absorbable Energy diagrams.
5	Calculate the energy consumed by the regenerative resistor.	$E_K$	$E_K = E_s - (E_L + E_M + E_C)$
6	Calculate the required regenerative resistor capacity (W).	$W_K$	$W_K = E_K / (0.2 \times T)$

Note: 1 The "0.2" in the equation for calculating  $W_K$  is the value for when the regenerative resistor's utilized load ratio is 20%.

2 The units for the various symbols are as follows:

$E_s$  to  $E_K$ : Energy joules (J)

$W_K$ : Regenerative resistor required capacity (W)

$J$ : ( $= J_M + J_L$ ) (kg·m<sup>2</sup>)

$nM$ : Servomotor rotation speed (min<sup>-1</sup>)

$T_L$ : Load torque (N·m)

$t_d$ : Deceleration stopping time (s)

$T$ : Servomotor repeat operation period (s)

If the above calculation determines that the amount of regenerative power ( $W_K$ ) processed by the built-in resistor is not exceeded, then an external regenerative resistor is not required. Refer to Specifications of Built-in Regenerative Resistor for regenerative resistors built into SERVOPACKs. If the amount of regenerative power that can be processed by the built-in resistor is exceeded, then install an external regenerative resistor for the capacity obtained from the above calculation.

If the energy consumed by load loss (in step 2 above) is unknown, then perform the calculation using  $E_L = 0$ .

When the operation period in regeneration mode is continuous, add the following items to the above calculation procedure in order to find the required capacity (W) for the regenerative resistor.

- Energy for continuous regeneration mode operation period:  $E_G$  (joules)
- Energy consumed by regenerative resistor:  $E_K = E_s - (E_L + E_M + E_C) + E_G$
- Required capacity of regenerative resistor:  $W_K = E_K / (0.2 \times T)$

Here,  $E_G = (2\pi / 60) nMG T_G t_G$

- $T_G$  : Servomotor's generated torque in continuous regeneration mode operation period (N·m)
- $nMG$  : Servomotor rotation speed for same operation period as above (min<sup>-1</sup>)
- $t_G$  : Same operation period as above(s)



## Selecting Regenerative Resistors

### (3) SERVOPACK's Absorbable Energy

The following diagrams show the relationship between the SERVOPACK's input power supply voltage and its absorbable energy.

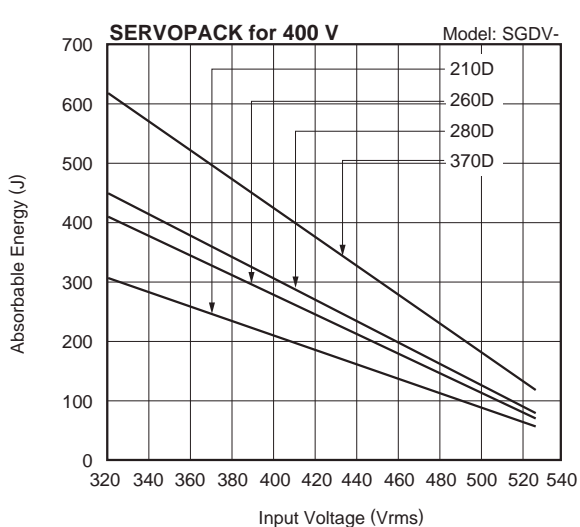
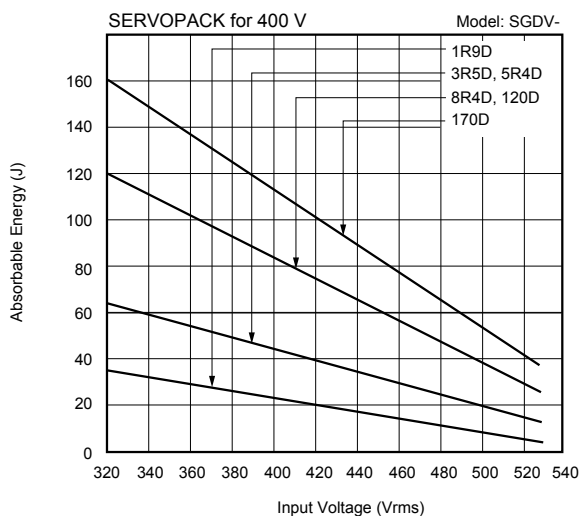
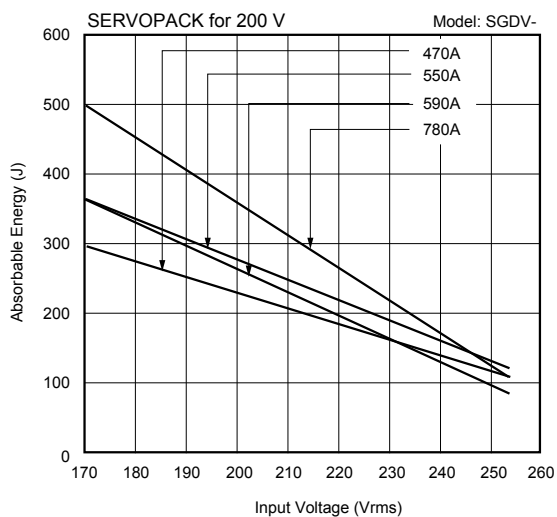
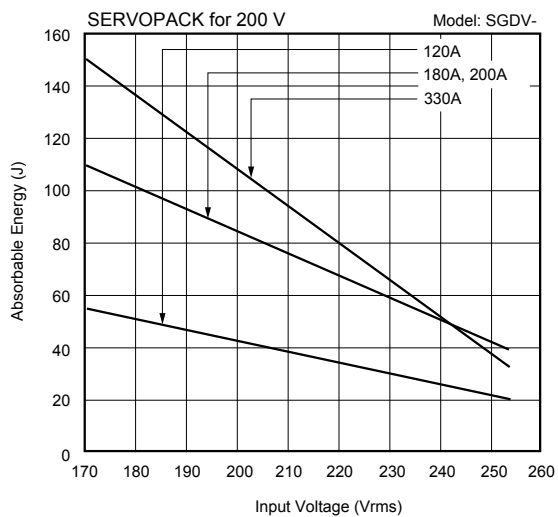
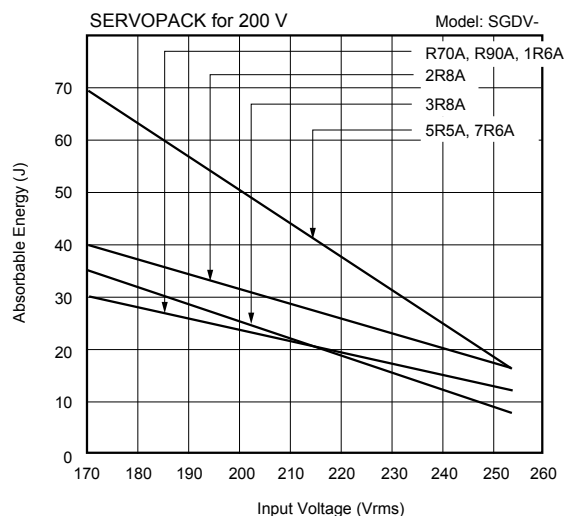
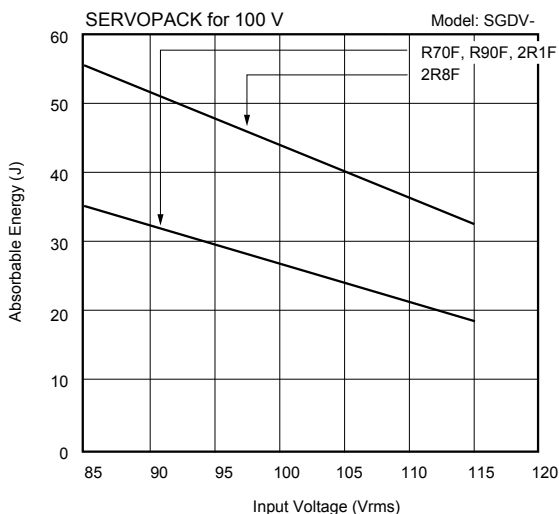

## Selecting Regenerative Resistors

### (4) Servomotor Winding Resistance Loss

The following diagrams show the relationship, for each servomotor, between the servomotor's generated torque and the winding resistance loss.

#### (a) SGMJV Rotary Servomotors

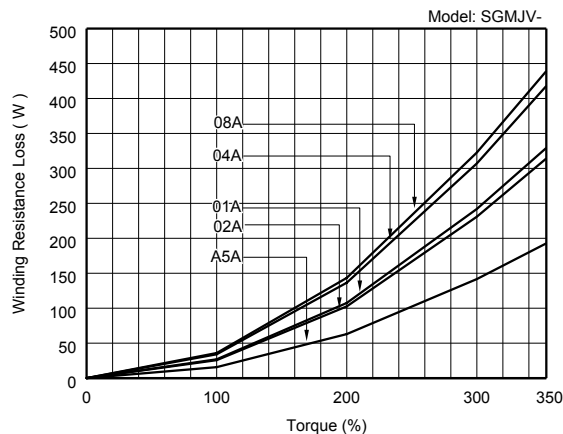

#### (b) SGMAV Rotary Servomotors

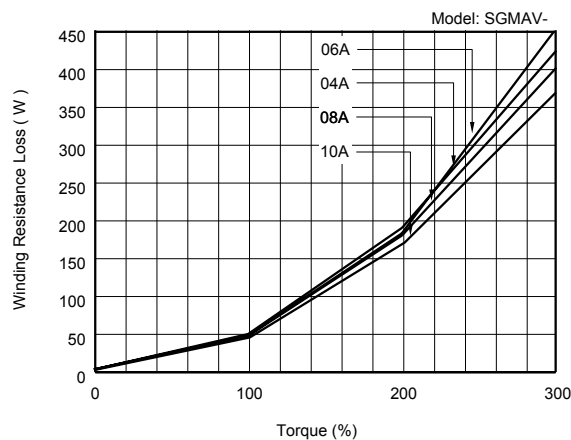
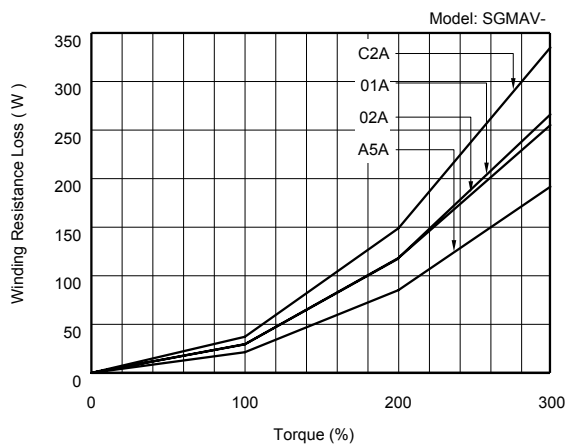

#### (c) SGMPS Rotary Servomotors

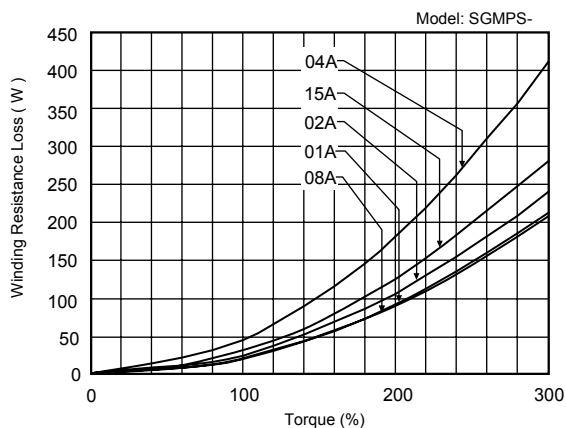

# Selecting Regenerative Resistors

(d) SGMGV Rotary Servomotors

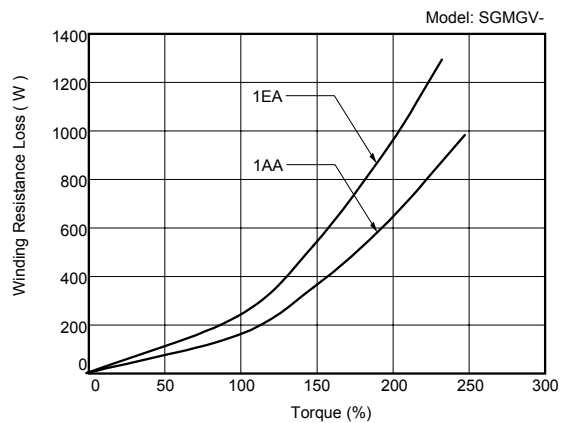
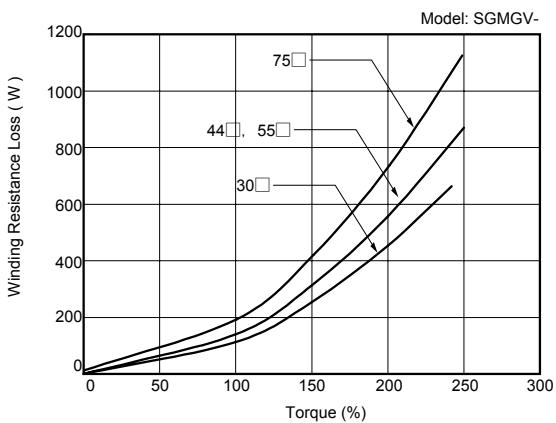
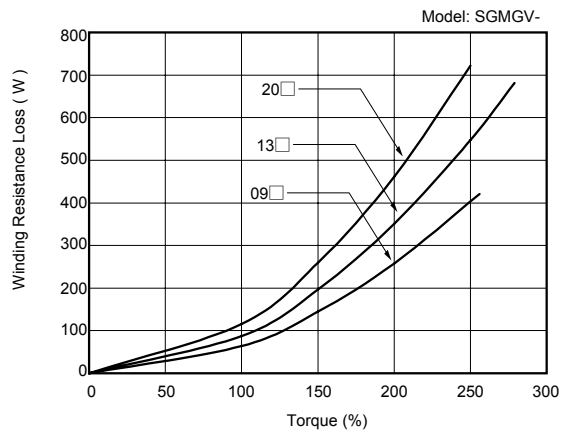
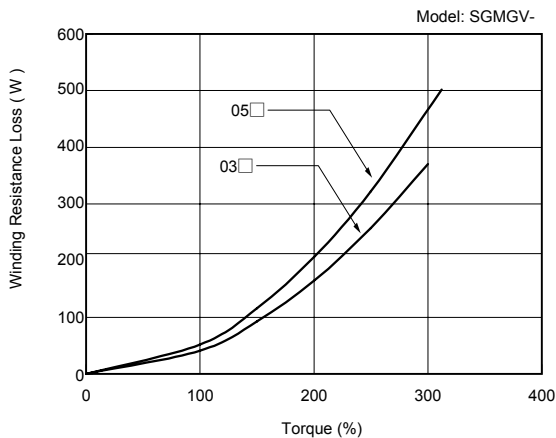

(e) SGMSV Rotary Servomotors

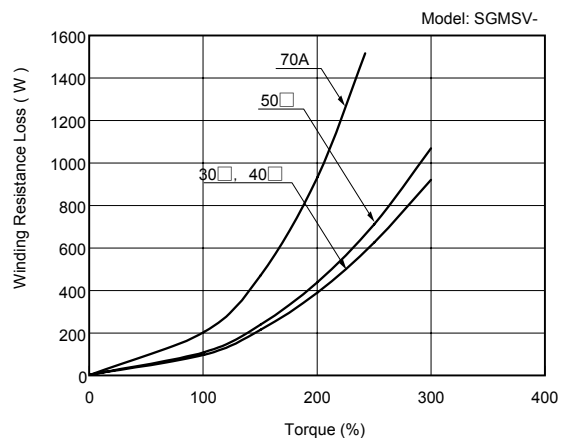
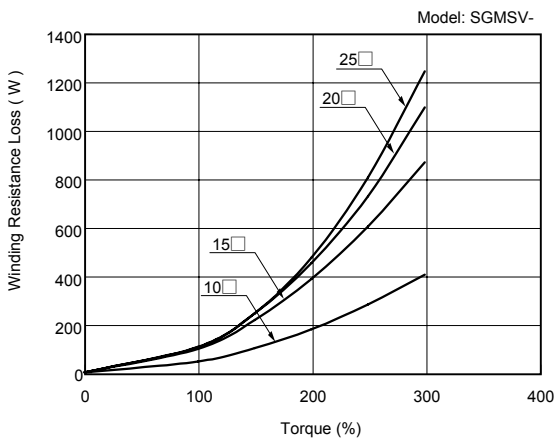

Selecting Regenerative Resistors

(f) SGMCS Direct Drive Servomotors

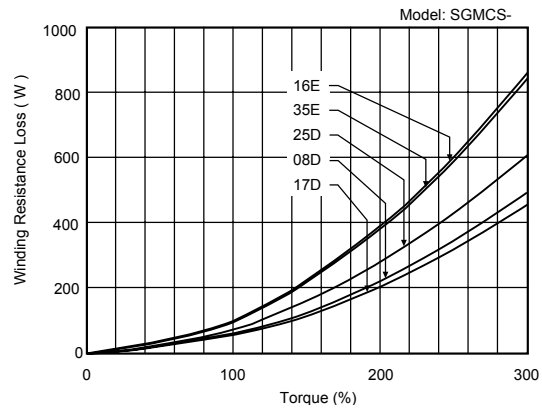
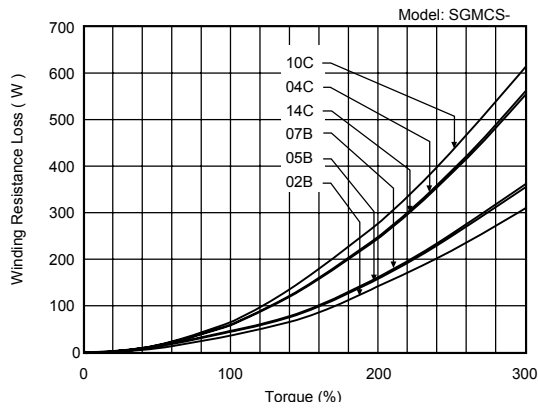

(g) SGLGW Linear Servomotors

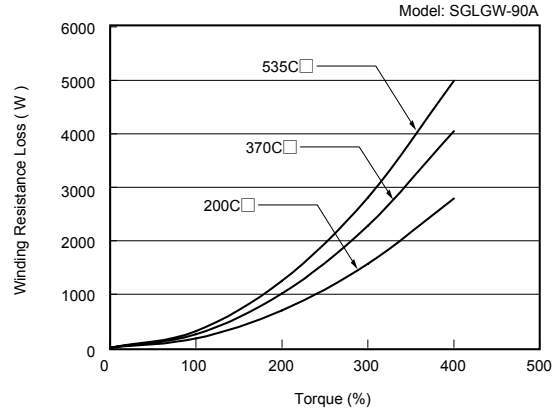
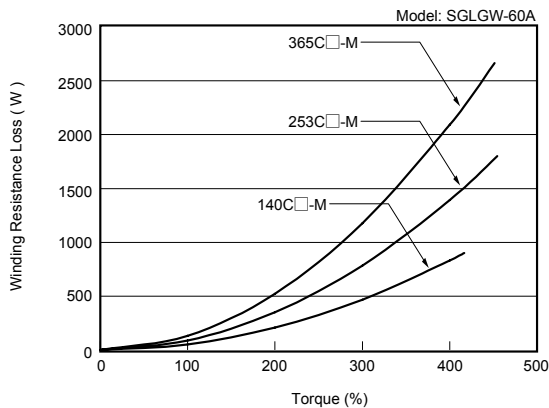
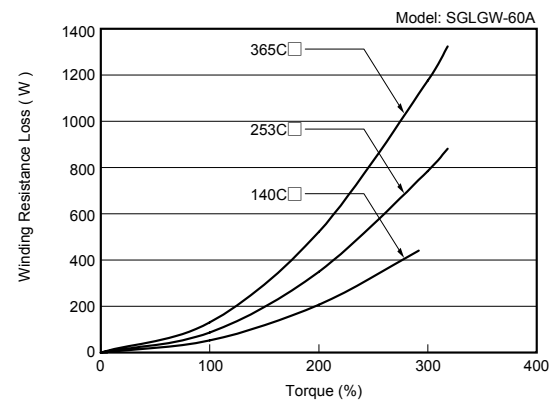
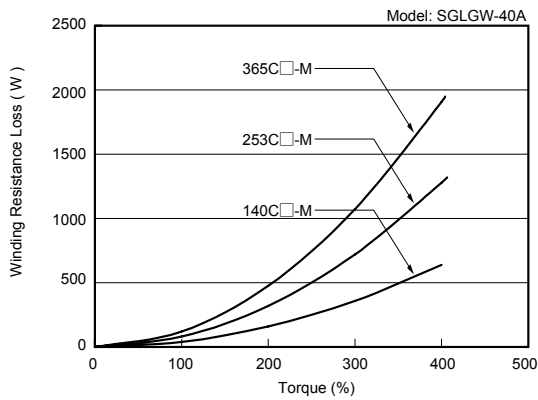
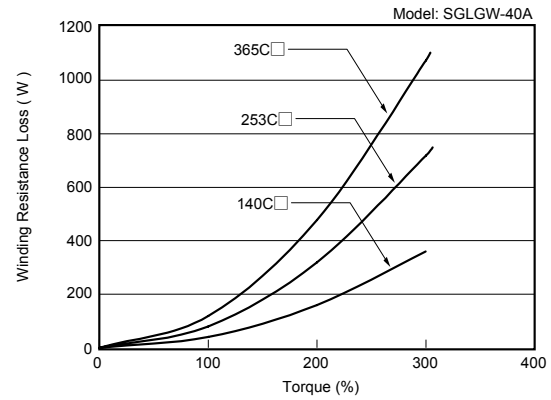
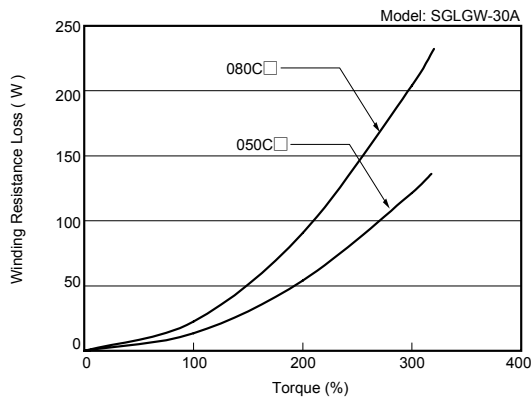

# Selecting Regenerative Resistors

## (h) SGLFW Linear Servomotors

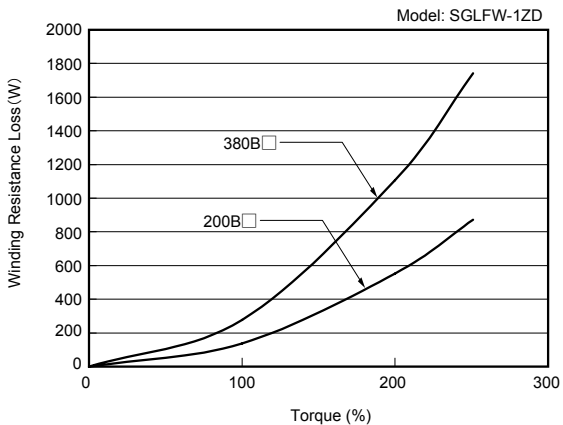
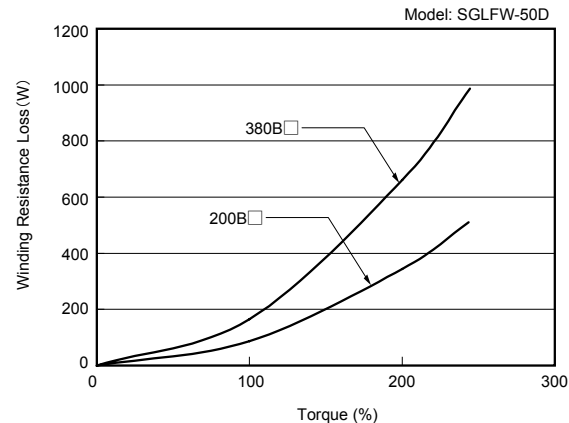
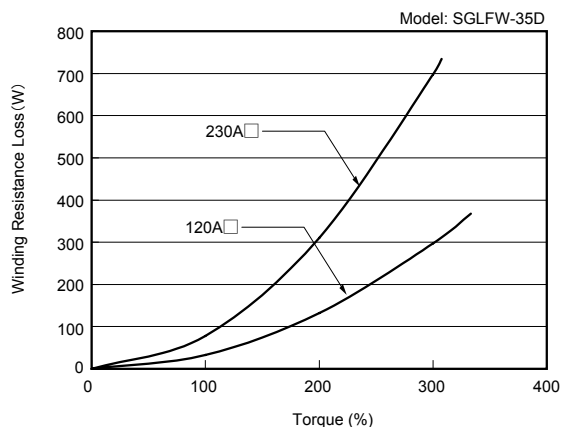
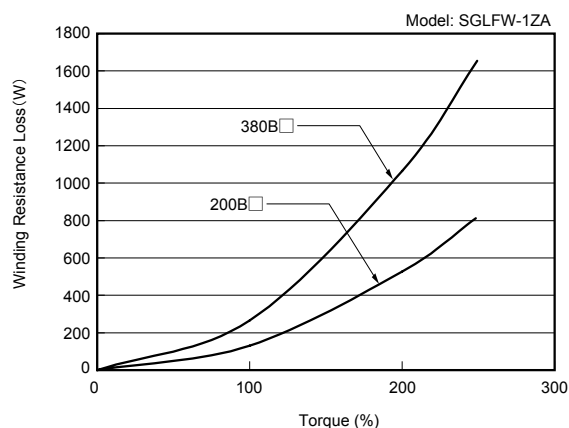
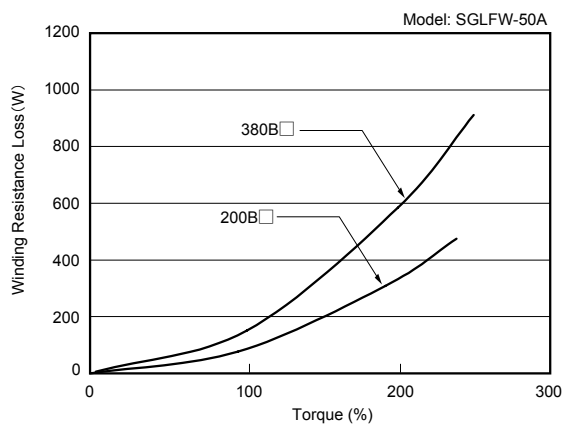
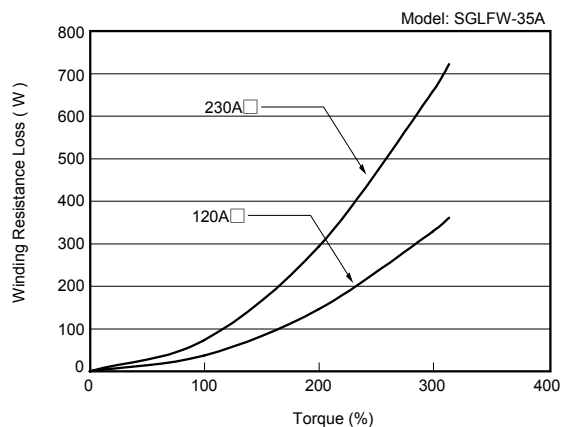
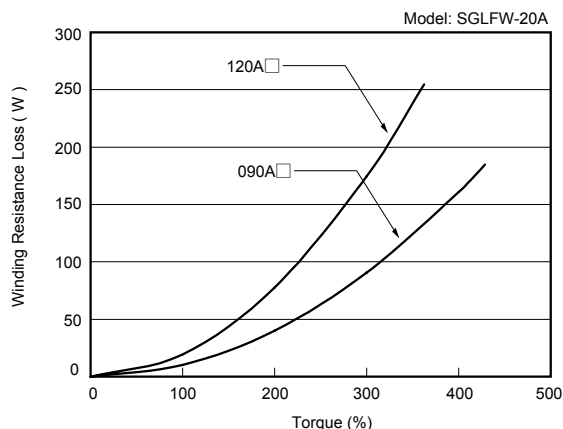

Selecting Regenerative Resistors

(i) SGLTW Linear Servomotors

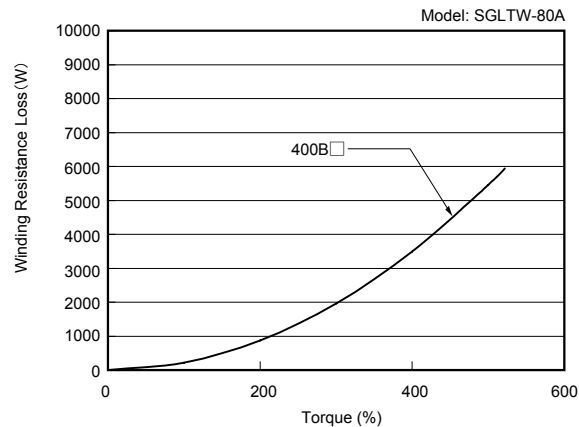
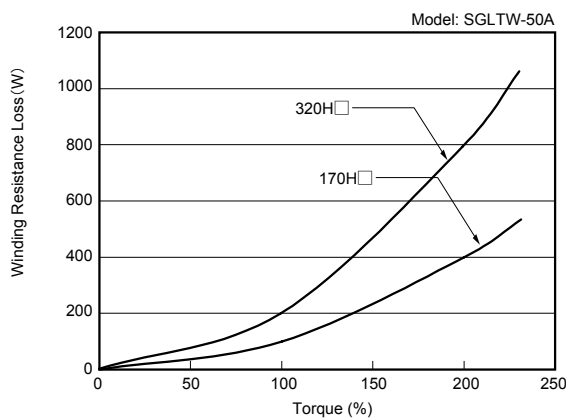
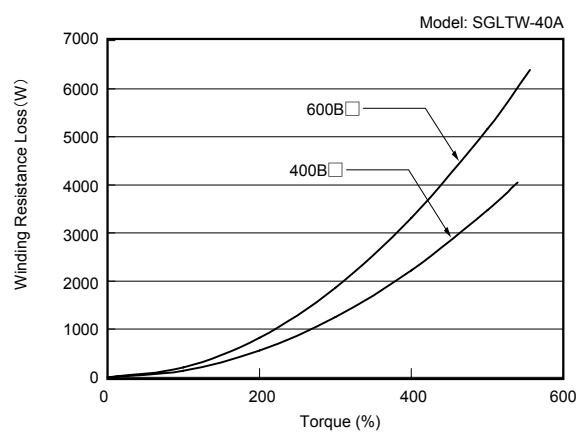
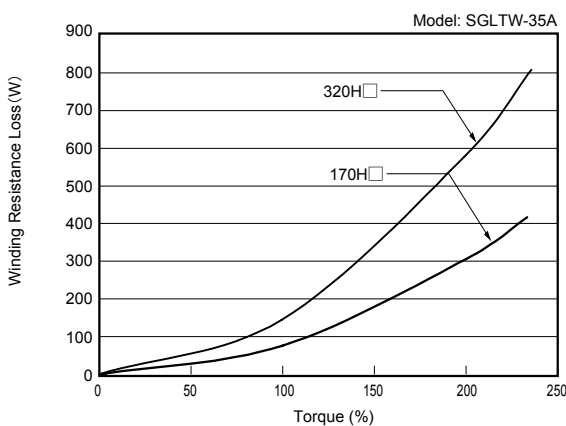
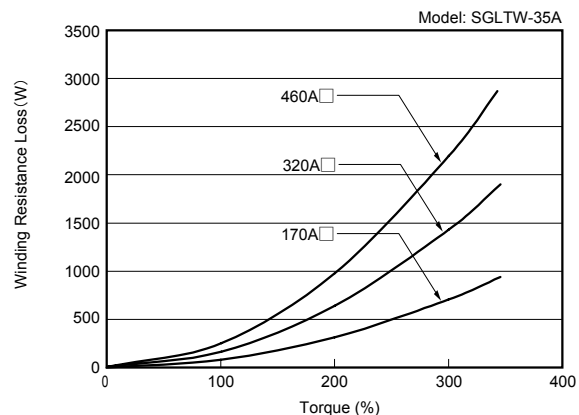
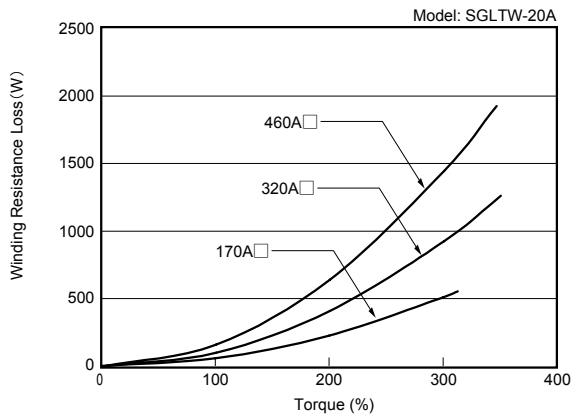

# Selecting Regenerative Resistors

## (i) SGLTW Linear Servomotors (cont'd)

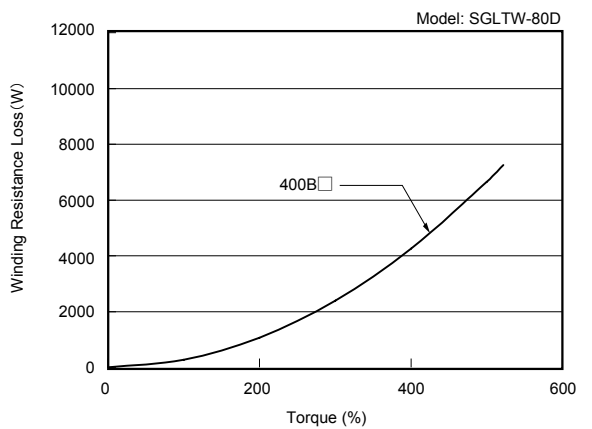
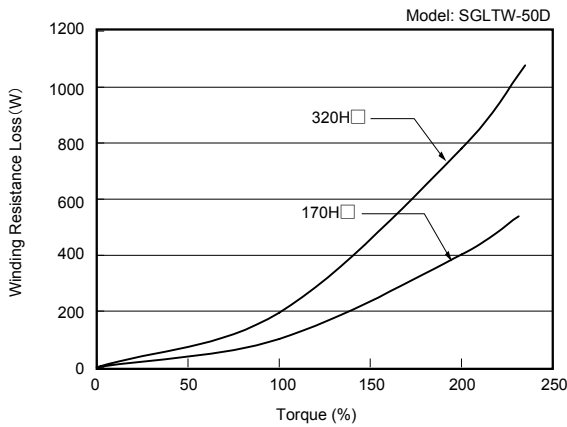
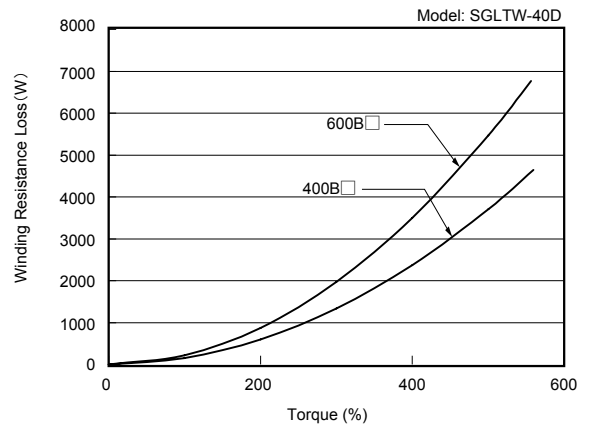
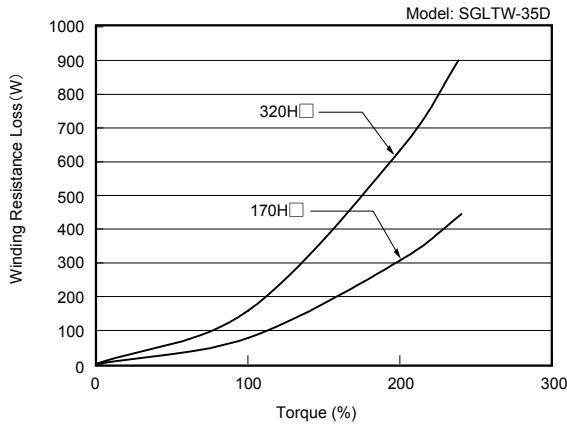

## (j) SGLCW Cylinder Type Linear Servomotors

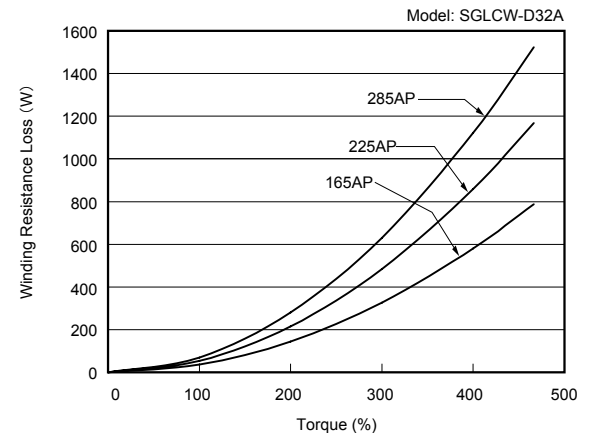
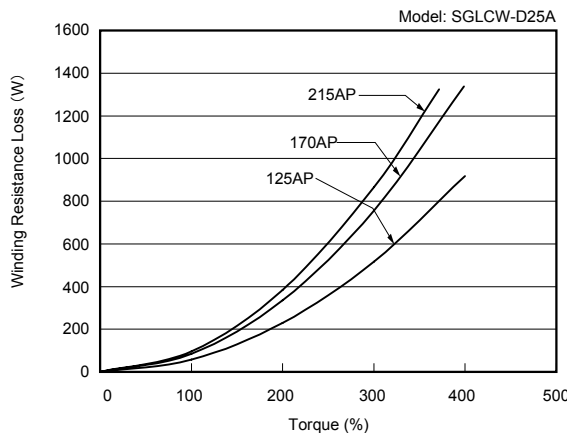
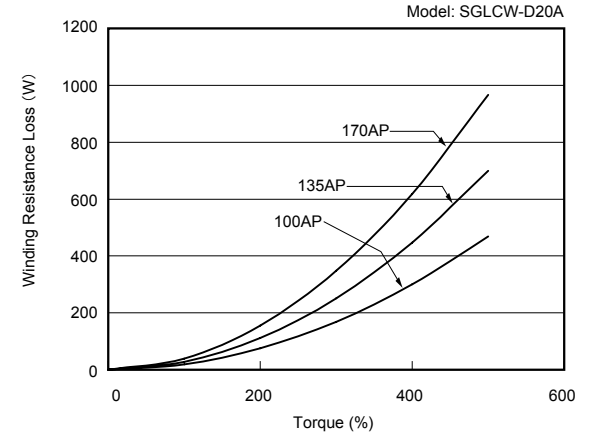
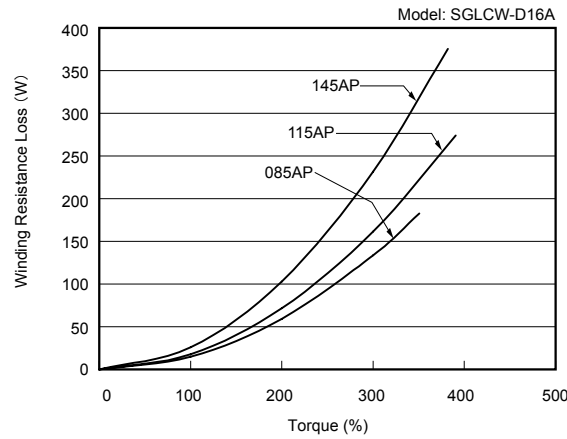

Selecting Regenerative Resistors

(k) SGT Linear Sliders

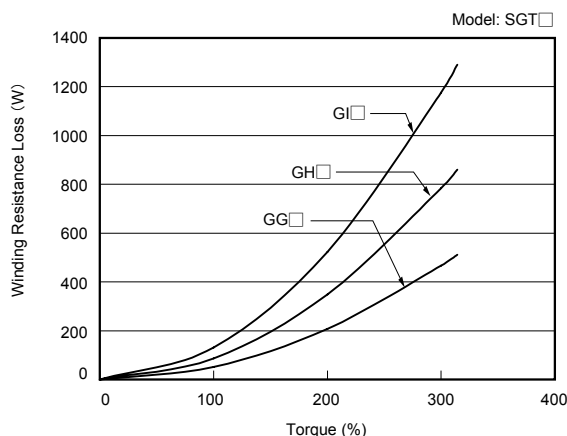
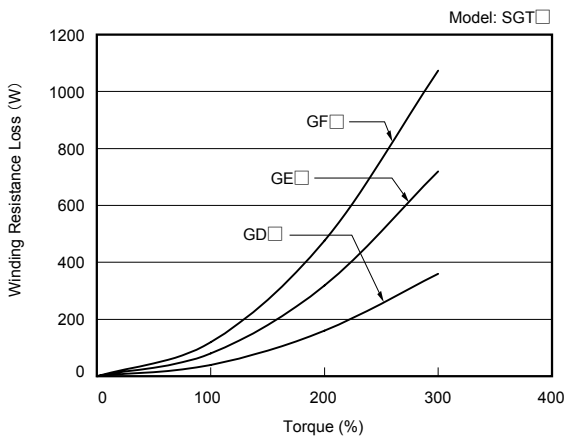
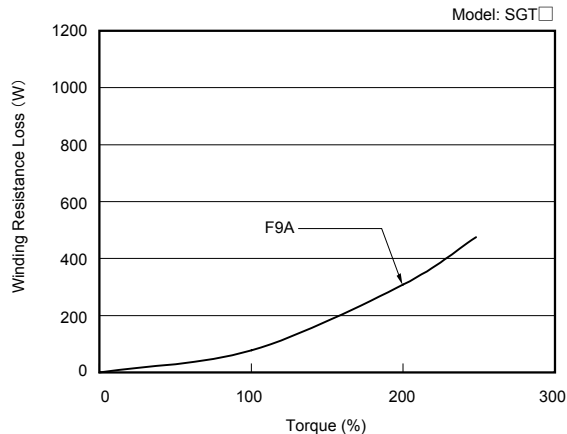
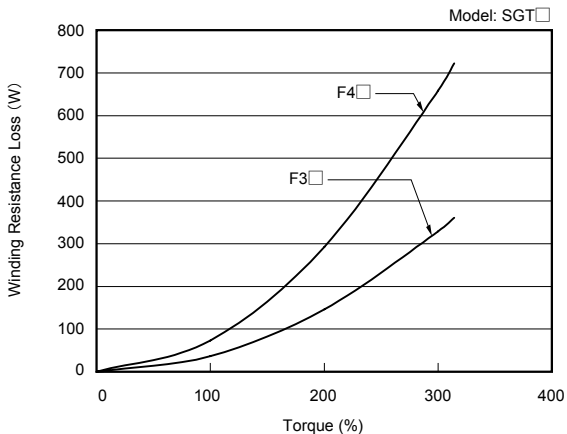





# Connection to Host Controller

## Example of Connection to Machine Controller MP2□□□

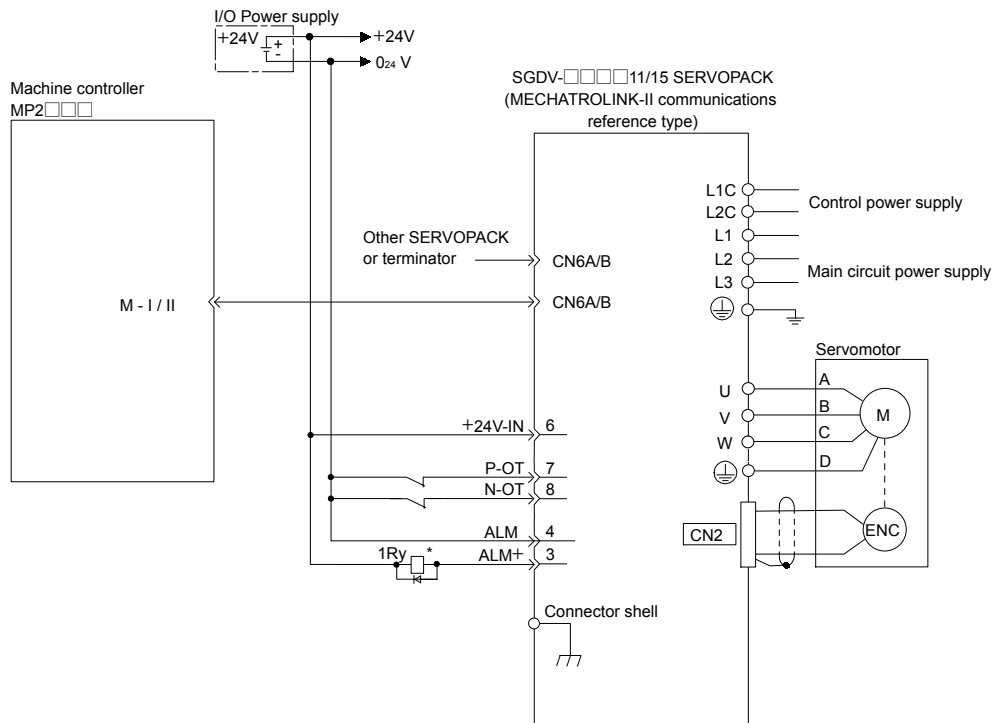

\*: The ALM signal is output for five seconds or less when the power is turned ON. Take this into consideration when designing the power ON sequence. The ALM signal actuates the alarm detection relay "1Ry" to stop the main circuit power supply to the SERVOPACK.

- Notes:
- 1 Only signals applicable to Machine Controller MP2□□□ and Yaskawa's SGD SERVOPACK are shown in the diagram.
  - 2 The main circuit power supply is a three-phase 200 VAC SERVOPACK input in the example.
  - 3 Note that incorrect connection will cause damage to the Machine Controller and SERVOPACK. Take particular care to wire correctly.
  - 4 Open the signal lines not to be used.
  - 5 The above connection diagram shows only X-axis connection. When using another axes, make connection to the SERVOPACK in the same way.
  - 6 The normally closed (N.C.) input terminals not to be used at the Machine Controller I/O connector section must be short-circuited at the connector.
  - 7 Make the setting so that the servo can be turned ON/OFF by the /S-ON signal.
  - 8 The SERVOPACK has a built-in safety function to protect prevent anyone in the vicinity from being injured by unexpected motion. But, in order to use the function, the circuit for CN8 is required to be configured. When not using the function, use SERVOPACKs with the Safety Jumper Connector connected.

## Example of Connection to MP2200 / MP2300 Motion Module SVA-01

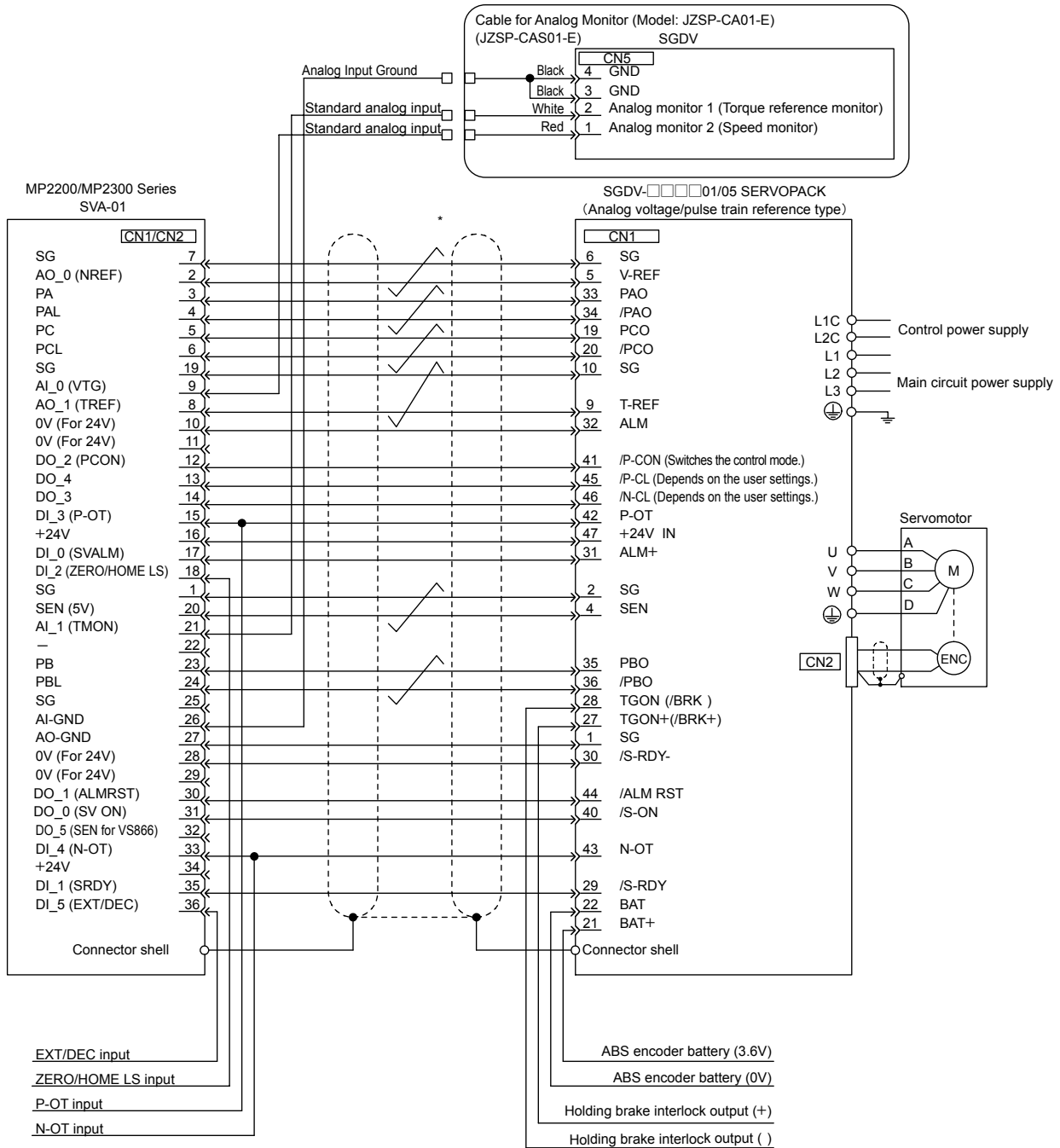

\*: represents twisted-pair wires.

- Notes:
- 1 Connection cables (model: JEPMC-W 2040-□□) to connect the SERVOPACK to the MP2200/MP2300 are provided by Yaskawa. For details, see "Machine Controller MP2200/MP2300 Motion Module User's Manual" (manual no. YEA-SIEPC88070016).
  - 2 Only signals applicable to MP2200 / MP2300 Motion Module SVA-01 and Yaskawa's SGD Servopack are shown in the diagram.
  - 3 The main circuit power supply is a three-phase 200 VAC SERVOPACK input in the example.
  - 4 Note that incorrect connection will cause damage to the Machine Controller and SERVOPACK. Take particular care to wire correctly.
  - 5 Open the signal lines not to be used.
  - 6 The above connection diagram shows only X-axis connection. When using another axes, make connection to the SERVOPACK in the same way.
  - 7 The normally closed (N.C.) input terminals not to be used at the Machine Controller I/O connector section must be short-circuited at the connector.
  - 8 Make the setting so that the servo can be turned ON/OFF by the /S-ON signal.
  - 9 The SERVOPACK has a built-in safety function to protect prevent anyone in the vicinity from being injured by unexpected motion. But, in order to use the function, the circuit for CN8 is required to be configured. When not using the function, use SER VOPACKs with the Safety Jumper Connector connected.

## Example of Connection to MP920 4-axis Analog Module SVA-01

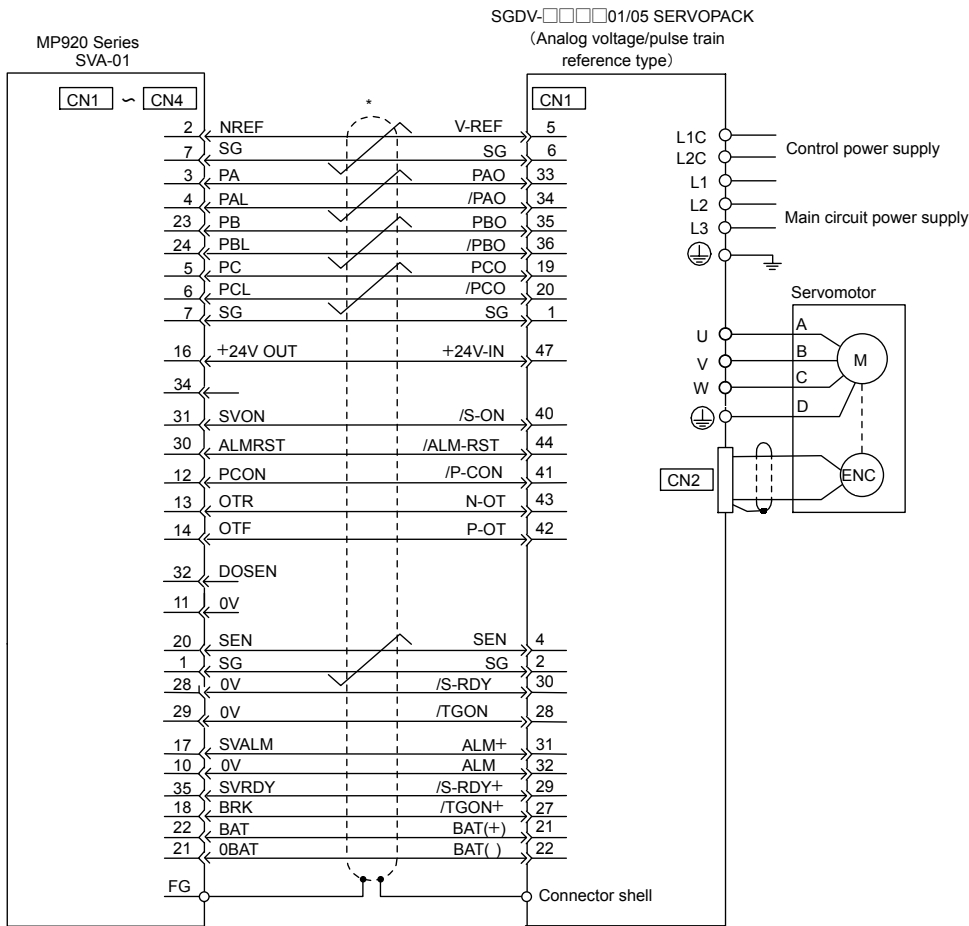

\*: represents twisted-pair wires.

- Notes:
- 1 Connection cables (model: JEPMC-W6050-□□) to connect the SER VOPACK to the MP920 are provided by Yaskawa. For details, see "Machine Controller MP920 User's Manual Design and Maintenance" (manual no. SIEZ-C887-2.1).
  - 2 Only signals applicable to MP920 4-axes Analog Module SVA-01 and Yaskawa's SGDV SERVOPACK are shown in the diagram.
  - 3 The main circuit power supply is a three-phase 200 VAC SERVOPACK input in the example.
  - 4 Note that incorrect connection will cause damage to the Machine Controller and SERVOPACK. Take particular care to wire correctly.
  - 5 Open the signal lines not to be used.
  - 6 The above connection diagram shows only X-axis connection. When using another axes, make connection to the SERVOPACK in the same way.
  - 7 The normally closed (N.C.) input terminals not to be used at the Machine Controller/I/O connector section must be short-circuited at the connector.
  - 8 Make the setting so that the servo can be turned ON/OFF by the /S-ON signal.
  - 9 The SERVOPACK has a built-in safety function to protect prevent anyone in the vicinity from being injured by unexpected motion. But, in order to use the function, the circuit for CN8 is required to be configured. When not using the function, use SERVOPACKs with the Safety Jumper Connector connected.

## Example of Connection to OMRON's Motion Control Unit

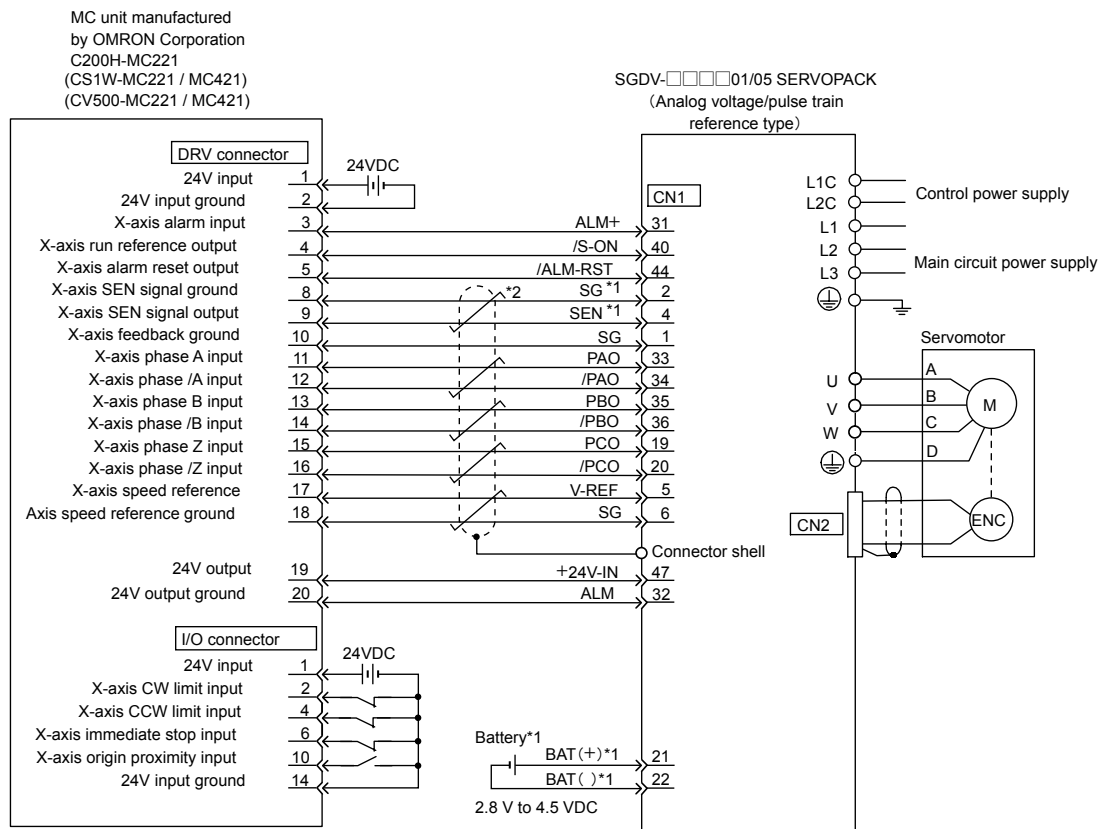

\*1: Use a battery when using an absolute encoder.

No battery is needed for CN1 (between 21, 22) when using an encoder cable with a battery.

- Battery for CN1 : ER6VC3N (3.6 V, 2000 mA)
- Battery for battery unit : JUSP-BA01-E (3.6 V, 1000 mA)

\*2:  represents twisted-pair wires.

Notes: 1 Only signals applicable to OMRON Corporation's MC unit and Yaskawa's SGDV SERVOPACK are shown in the diagram.

2 The main circuit power supply is a three-phase 200 VAC SERVOPACK input in the example.

3 Note that incorrect connection will cause damage to the MC unit and SERVOPACK.

Take particular care to wire correctly.

4 Open the signal lines not to be used.

5 The above connection diagram shows only X-axis connection. When using another axes, make connection to the SERVOPACK in the same way.

6 The normally closed (N.C.) input terminals not to be used at the motion control unit I/O connector section must be short-circuited at the connector.

7 Make the setting so that the servo can be turned ON/OFF by the /S-ON signal.

8 The SERVOPACK has a built-in safety function to prevent anyone in the vicinity from being injured by unexpected motion. But, in order to use the function, the circuit for CN8 is required to be configured. When not using the function, use SERVOPACKs with the Safety Jumper Connector connected.

## Example of Connection to OMRON's Position Control Unit

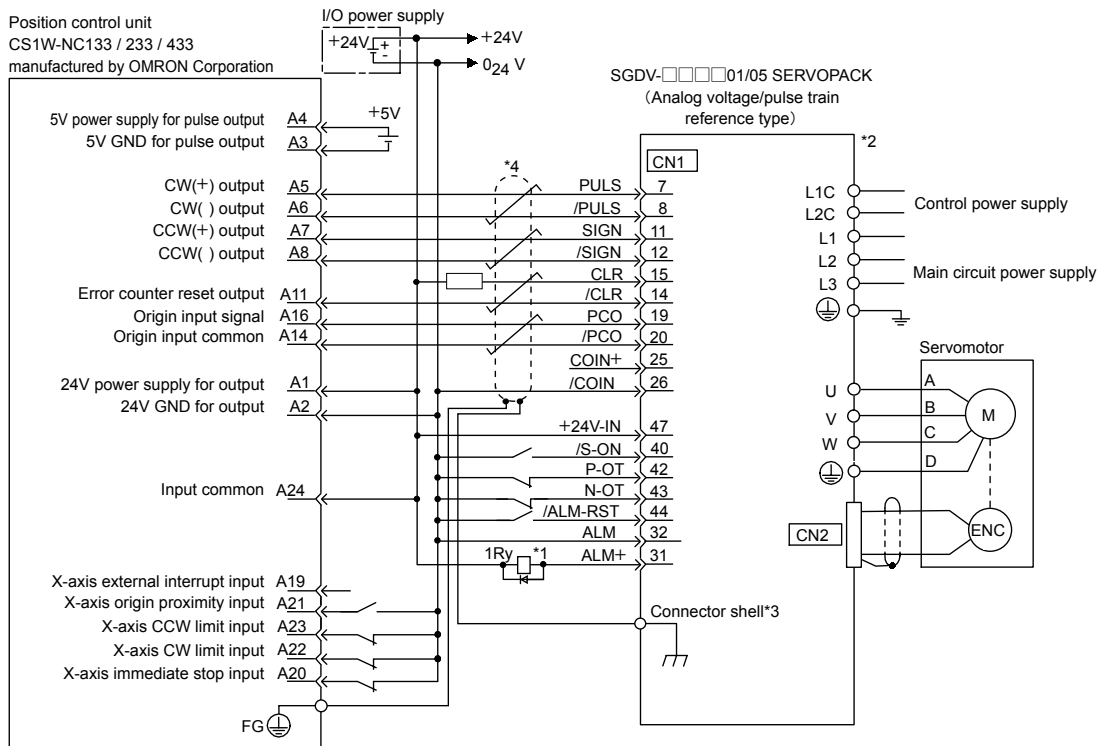

\*1: The ALM signal is output for five seconds or less when the power is turned ON. Take this into consideration when designing the power ON sequence. The ALM signal actuates the alarm detection relay "1Ry" to stop the main circuit power supply to the SERVOPACK.

\*2: Set parameter Pn200.0 = 1 or 6.

\*3: Connect the shield wire to the connector shell.

\*4  represents twisted-pair wires.

Notes: 1 Only signals applicable to OMRON Corporation's position control unit and Yaskawa's SGD-V SERVOPACK are shown in the diagram.

2 The main circuit power supply is a three-phase 200 VAC SERVOPACK input in the example.

3 Note that incorrect connection will cause damage to the position control unit and SERVOPACK. Take particular care to wire correctly.

4 Open the signal lines not to be used.

5 The above connection diagram shows only X-axis connection. When using another axes, make connection to the SERVOPACK in the same way.

6 The normally closed (N.C.) input terminals not to be used at the position control unit I/O connector section must be short-circuited at the connector.

7 Make the setting so that the servo can be turned ON/OFF by the /S-ON signal.

8 The SERVOPACK has a built-in safety function to prevent anyone in the vicinity from being injured by unexpected motion. But, in order to use the function, the circuit for CN8 is required to be configured. When not using the function, use SERVOPACKs with the Safety Jumper Connector connected.

## Example of Connection to Mitsubishi's AD72 Positioning Unit (SERVOPACK in Speed Control)

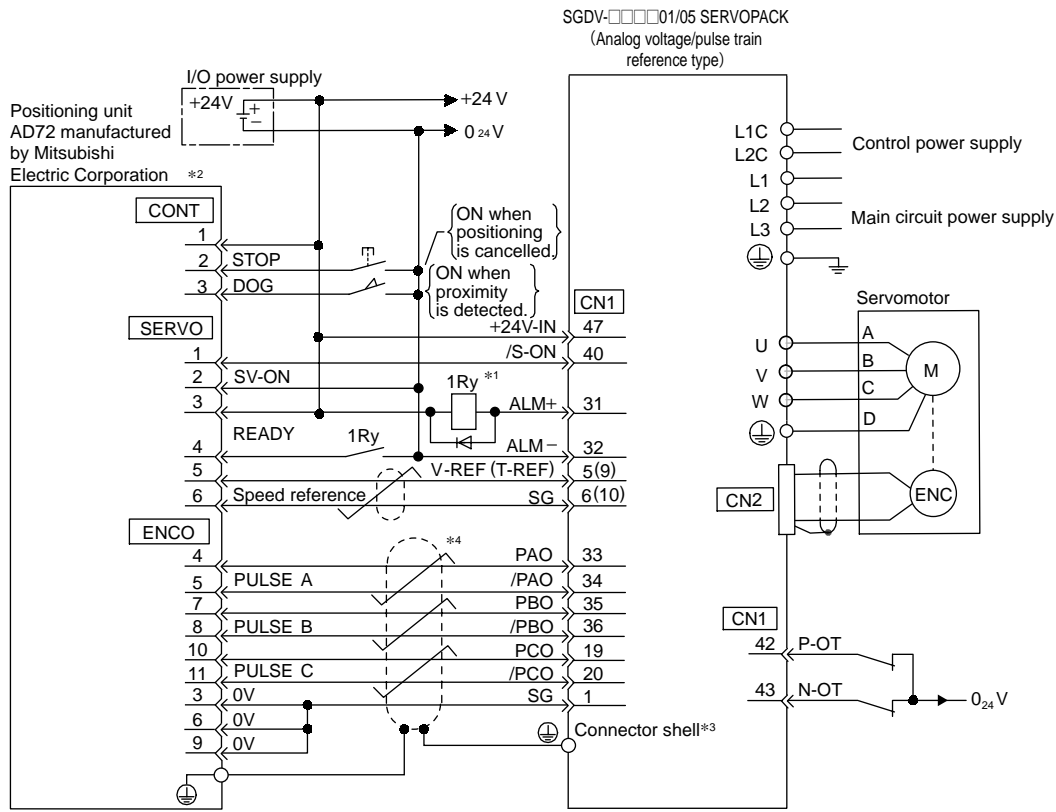

\*1: The ALM signal is output for five seconds or less when the power is turned ON. Take this into consideration when designing the power ON sequence. The ALM signal actuates the alarm detection relay "1Ry" to stop the main circuit power supply to the SERVOPACK.

\*2: Pin numbers are the same both for X-axis and Y-axis.

\*3: Connect the shield wire to the connector shell.

\*4:  represents twisted-pair wires.

Notes: 1 Only signals applicable to Mitsubishi Electric Corporation's AD72 positioning unit and Yaskawa's SGDV SERVOPACK are shown in the diagram.

2 The main circuit power supply is a three-phase 200 VAC SERVOPACK input in the example.

3 Note that incorrect connection will cause damage to the positioning unit and SERVOPACK. Take particular care to wire correctly.

4 Open the signal lines not to be used.

5 The above connection diagram shows only X-axis connection. When using another axes, make connection to the SERVOPACK in the same way.

6 The normally closed (N.C.) input terminals not to be used at the positioning unit I/O connector section must be short-circuited at the connector.

7 Make the setting so that the servo can be turned ON/OFF by the /S-ON signal.

8 The SERVOPACK has a built-in safety function to prevent anyone in the vicinity from being injured by unexpected motion. But, in order to use the function, the circuit for CN8 is required to be configured. When not using the function, use SERVOPACKs with the Safety Jumper Connector connected.

## Example of Connection to Mitsubishi's AD75 Positioning Unit (SERVOPACK in Position Control)

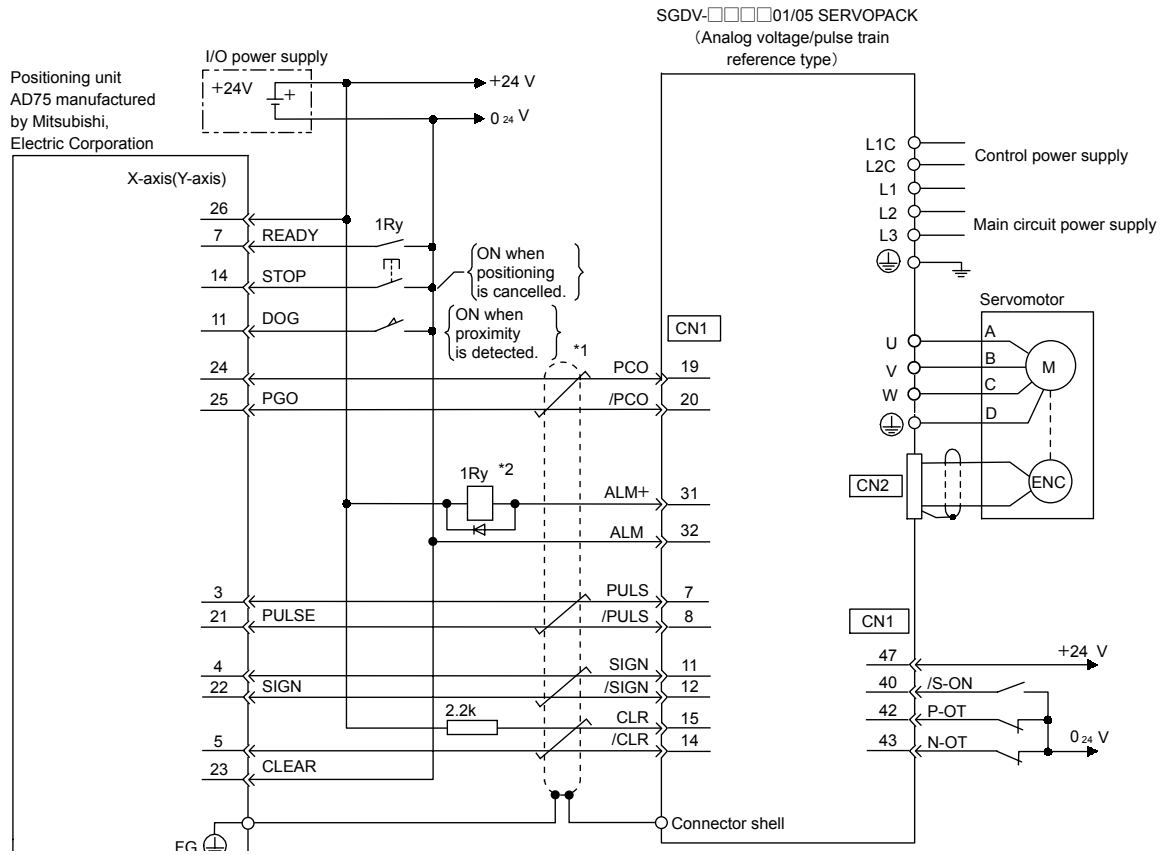

\*1: represents twisted-pair wires.

\*2: The ALM signal is output for five seconds or less when the power is turned ON. Take this into consideration when designing the power ON sequence. The ALM signal actuates the alarm detection relay "1Ry" to stop the main circuit power supply to the SERVOPACK.

Notes: 1 Only signals applicable to Mitsubishi Electric Corporation's AD75 positioning unit and Yaskawa's SGDV SERVOPACK are shown in the diagram.

2 The main circuit power supply is a three-phase 200 VAC SERVOPACK input in the example.

3 Note that incorrect connection will cause damage to the positioning unit and SERVOPACK. Take particular care to wire correctly.

4 Open the signal lines not to be used.

5 The above connection diagram shows only X-axis connection. When using another axes, make connection to the SERVOPACK in the same way.

6 The normally closed (N.C.) input terminals not to be used at the positioning unit I/O connector section must be short-circuited at the connector.

7 Make the setting so that the servo can be turned ON/OFF by the /S-ON signal.

8 The SERVOPACK has a built-in safety function to prevent anyone in the vicinity from being injured by unexpected motion. But, in order to use the function, the circuit for CN8 is required to be configured. When not using the function, use SERVOPACKs with the Safety Jumper Connector connected.

## Example of Connection to Mitsubishi's QD75D Positioning Unit (SERVOPACK in Positioning Control)

Positioning unit  
QD75D manufactured  
by Mitsubishi  
Electric Corporation

SGDV-000001/05 SERVOPACK  
(Analog voltage/pulse train  
reference type)

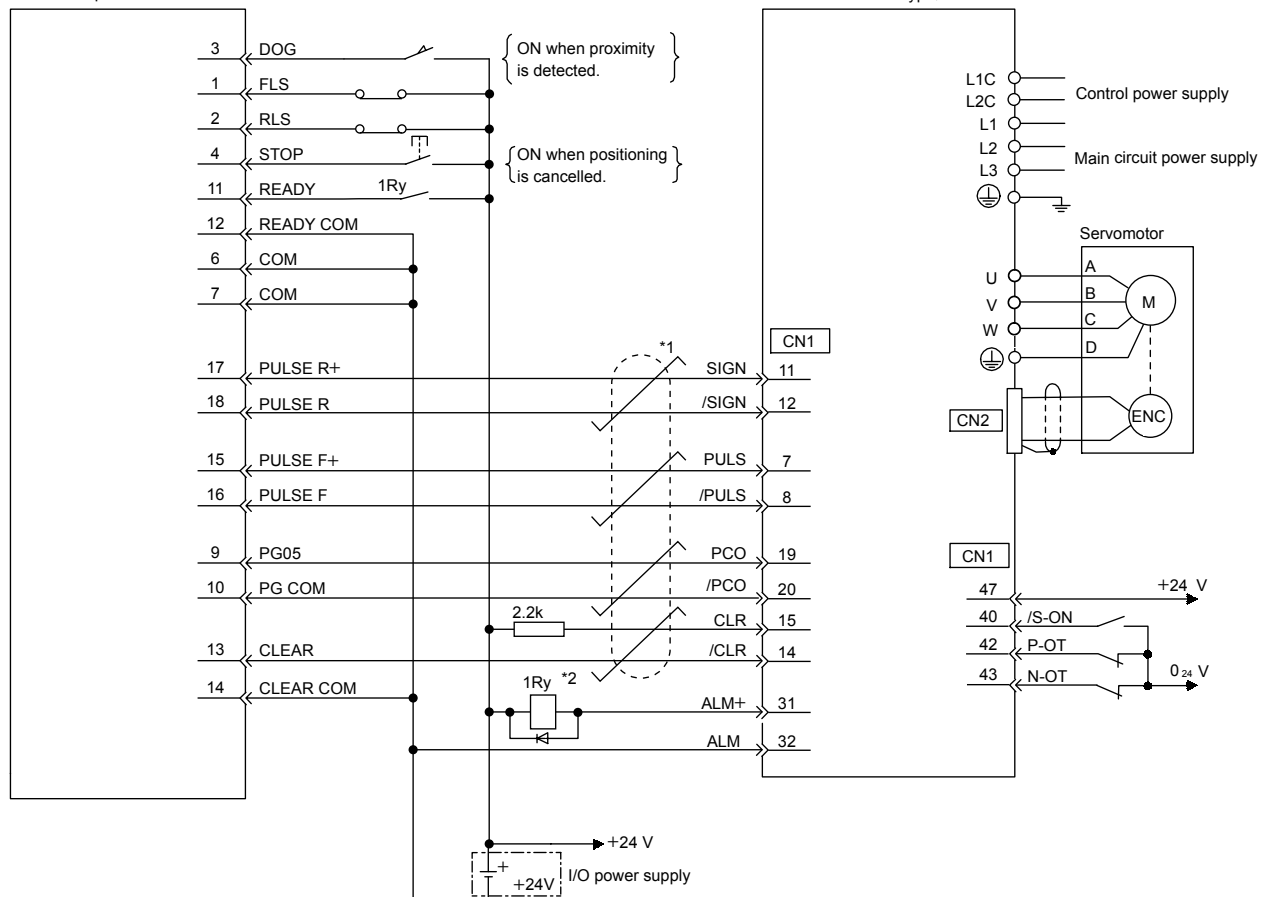

\*1:  represents twisted-pair wires.

\*2: The ALM signal is output for five seconds or less when the power is turned ON. Take this into consideration when designing the power ON sequence. The ALM signal actuates the alarm detection relay "1Ry" to stop the main circuit power supply to the SERVOPACK.

Notes: 1 Only signals applicable to Mitsubishi Electric Corporation's QD75D positioning unit and Yaskawa's SGDV SERVOPACK are shown in the diagram.

2 The main circuit power supply is a three-phase 200 VAC SERVOPACK input in the example.

3 Note that incorrect connection will cause damage to the positioning unit and SERVOPACK. Take particular care to wire correctly.

4 Open the signal lines not to be used.

5 The above connection diagram shows only X-axis connection. When using another axes, make connection to the SERVOPACK in the same way.

6 The normally closed (N.C.) input terminals not to be used at the positioning unit I/O connector section must be short-circuited at the connector.

7 Make the setting so that the servo can be turned ON/OFF by the /S-ON signal.

8 The SERVOPACK has a built-in safety function to prevent anyone in the vicinity from being injured by unexpected motion. But, in order to use the function, the circuit for CN8 is required to be configured. When not using the function, use SERVOPACKs with the Safety Jumper Connector connected.



# YASKAWA



**Yaskawa America, Inc.**  
Drives & Motion Division

2121 Norman Drive South  
Waukegan, IL 60085  
Tel: 1-800-YASKAWA (927-5292) • Fax: 1-847-887-7310  
MotionSupport@yaskawa.com • www.yaskawa.com

Document YEA-KAEPS80000042 • Rev: K-12 • 5/1/2017 • © 2011-2017