

YASKAWA

# SIGMA-7 SERVO SYSTEMS

AC SERVO DRIVES AND MOTORS  
TECHNICAL SUPPLEMENT

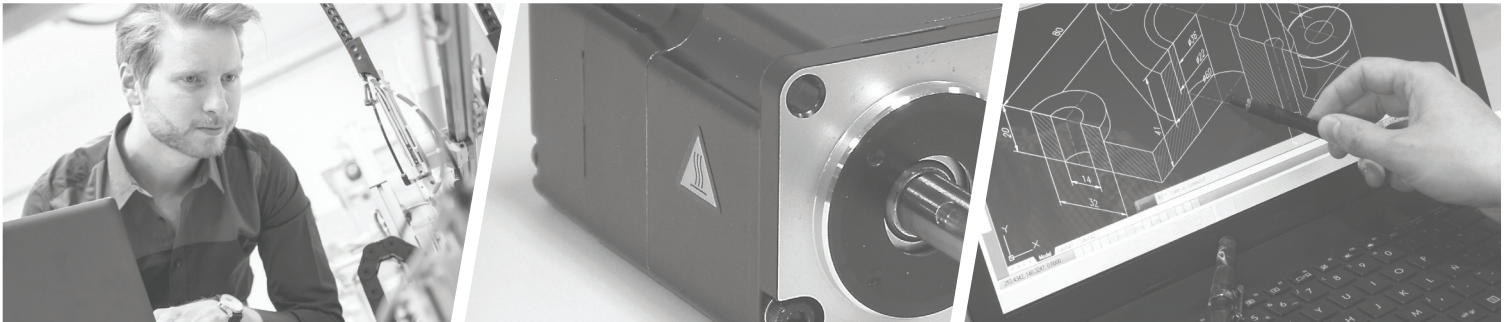

---

NEW SERVO TECHNOLOGY  
LIFTS SPEED,  
PRECISION AND  
PRODUCTIVITY TO  
THE NEXT LEVEL



# Product Lineup

## Servomotors

### ◆ Rotary Servomotors



SGMMV (Low inertia, ultra-small capacity)  
10 W to 30 W



SGM7J (Medium inertia, high speed)  
50 W to 1.5 kW



SGM7A (Low inertia, high speed)  
50 W to 7 kW

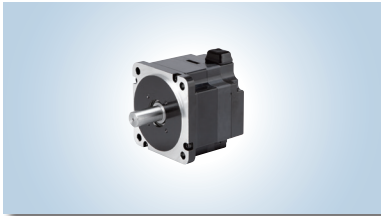

SGM7P (Medium inertia, flat type)  
100 W to 1.5 kW



SGM7G (Medium inertia, large torque)  
300 W to 15 kW

### ◆ Direct Drive Servomotors

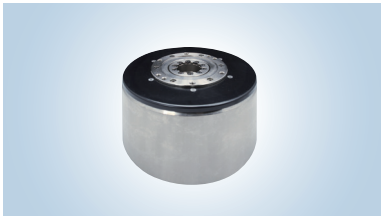

Small capacity, with core, inner rotor (SGM7F)  
2 Nm to 35 Nm

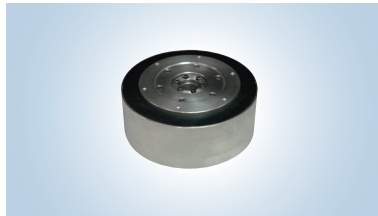

Small capacity, coreless (SGMCS)  
2 Nm to 35 Nm

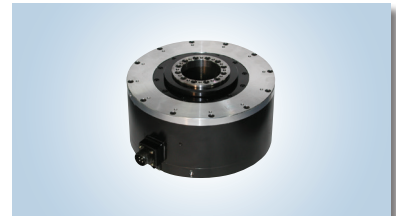

Medium capacity, with core (SGMCS)  
45 Nm to 200 Nm

### ◆ Linear Servomotors



SGLG (Coreless model)  
12.5 N to 750 N

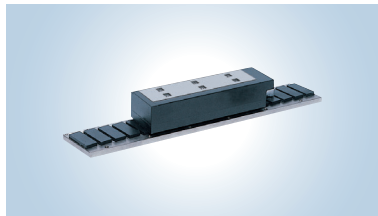

SGLFW (Model with F-type iron core)  
25 N to 1120 N



SGLT (Model with T-type iron core)  
130 N to 900 N

## SERVOPACKs

- ◆ Single-axis MECHATROLINK-III Communications Reference



SGD7S-□□□□30A

- ◆ Two-axis MECHATROLINK-III Communications Reference



SGD7W-□□□A30A

- ◆ Single-axis EtherCAT Communications Reference



SGD7S-□□□□A0A

- ◆ Single-axis Analog Voltage/Pulse Train Reference



SGD7S-□□□□00A

## Additional Options

- ◆ Fully-Closed Module



SGDV-OFA01A

- ◆ Advanced Safety Module



SGDV-OA01A

- ◆ Single-Axis Control Option (Sigma-7Siec)



SGD7S-□□□AM0A000F50

- ◆ 1.5 Axis Control Option (MP2600iec)



SGD7S-□□□AE0A000300

- ◆ Network Indexer Option (SigmaLogic7 Compact)



SGD7S-□□□AQ0A000F51

- ◆ Special Purpose Options (FT Options)



SGD7S-□□□A□0A000F□□

- F19: Less Deviation Control
- F79: Built-in Indexer
- F81: Harmonic Drive SHA Actuators



# System Configuration Example

## Combination of $\Sigma$ -7S SERVOPACK and Rotary Servomotor/Direct Drive Servomotor

- For MECHATROLINK-III Communications  
Three-phase 200 VAC

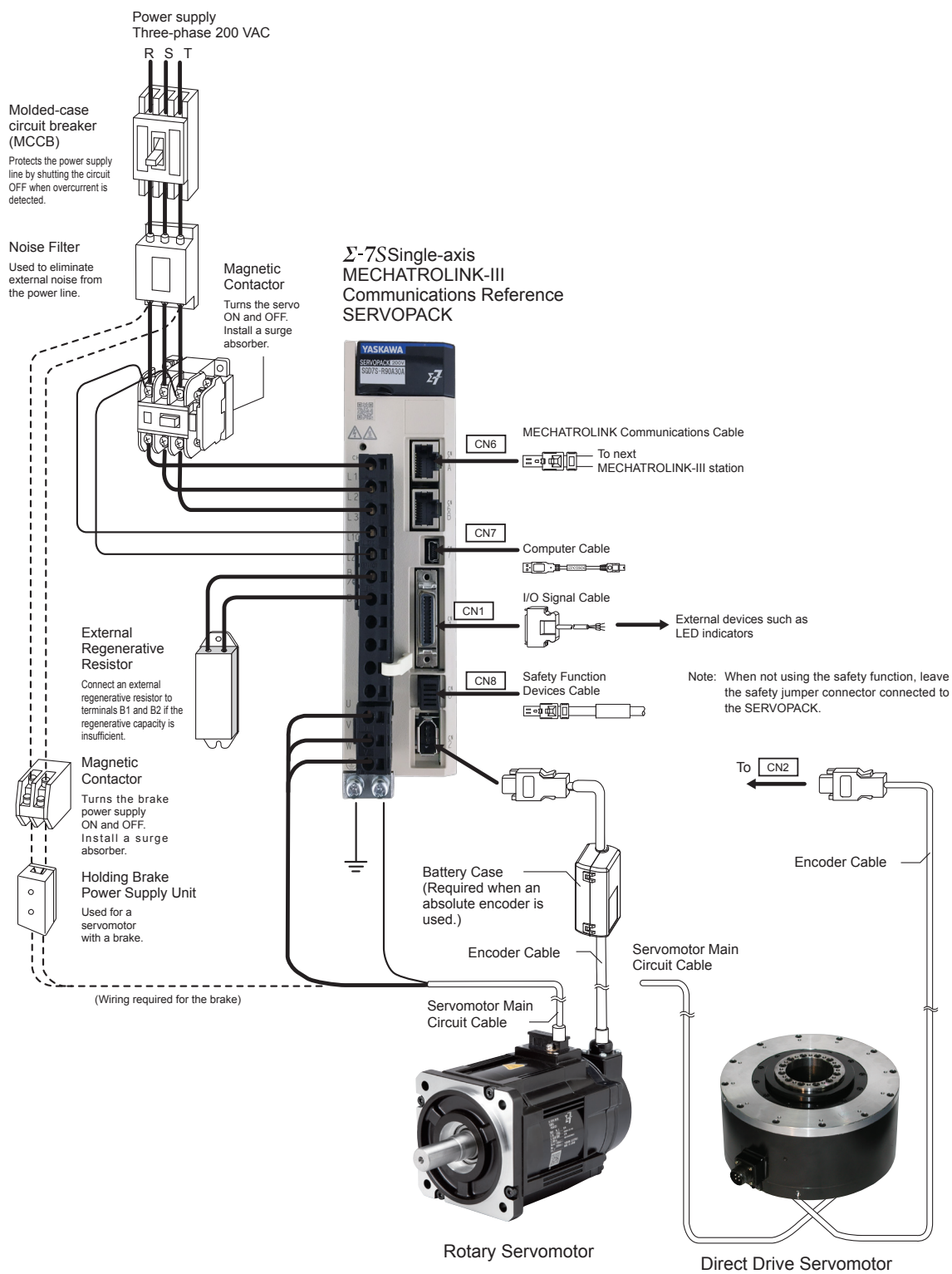

## Combination of $\Sigma$ -7S SERVOPACK and Linear Servomotor

### ● For MECHATROLINK-III Communications Three-phase 200 VAC

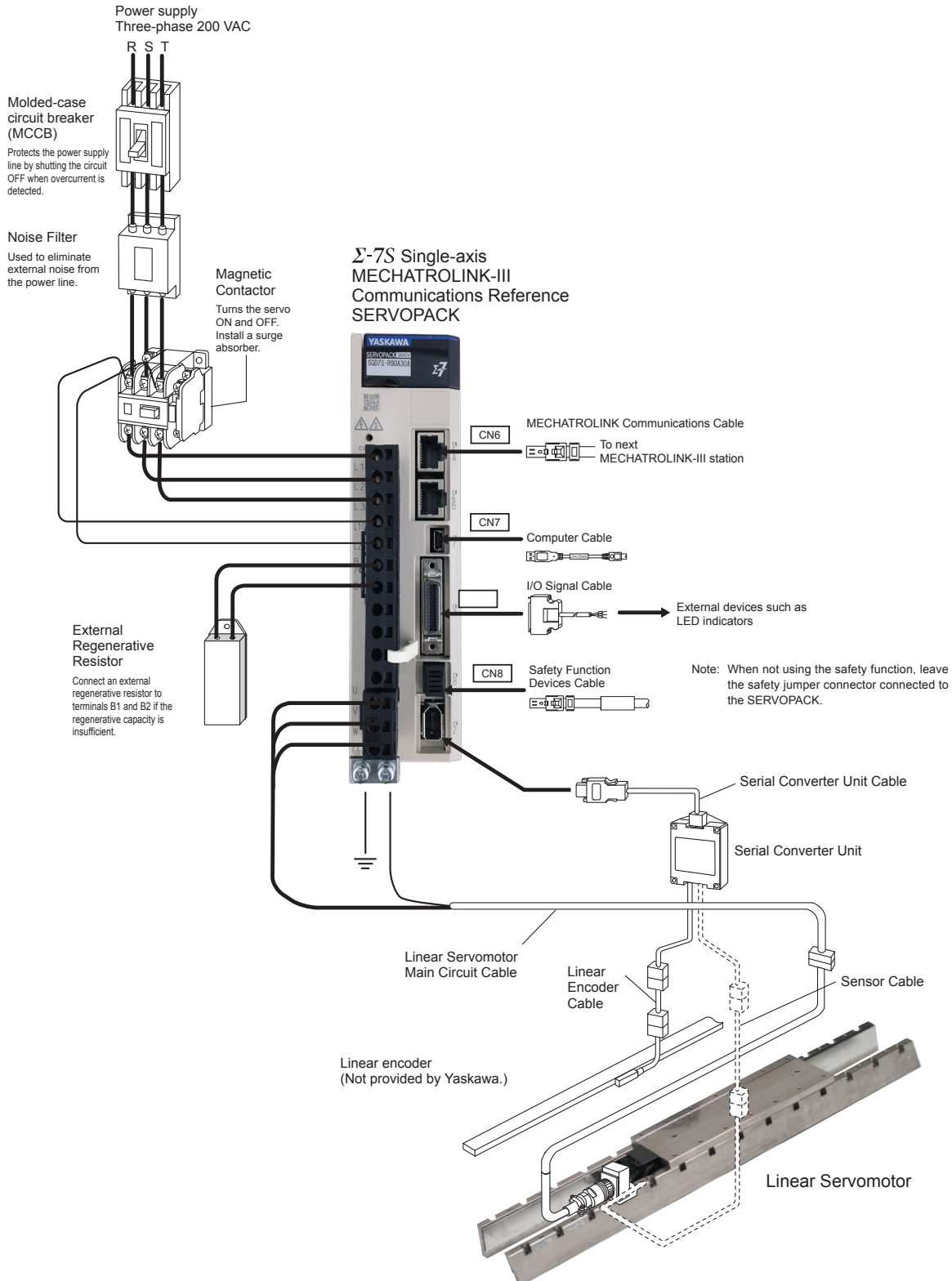



# System Configuration Example

Combination of  $\Sigma$ -7W SERVOPACK and Rotary Servomotor/Direct Drive Servomotor

- For MECHATROLINK-III Communications  
Three-phase 200 VAC

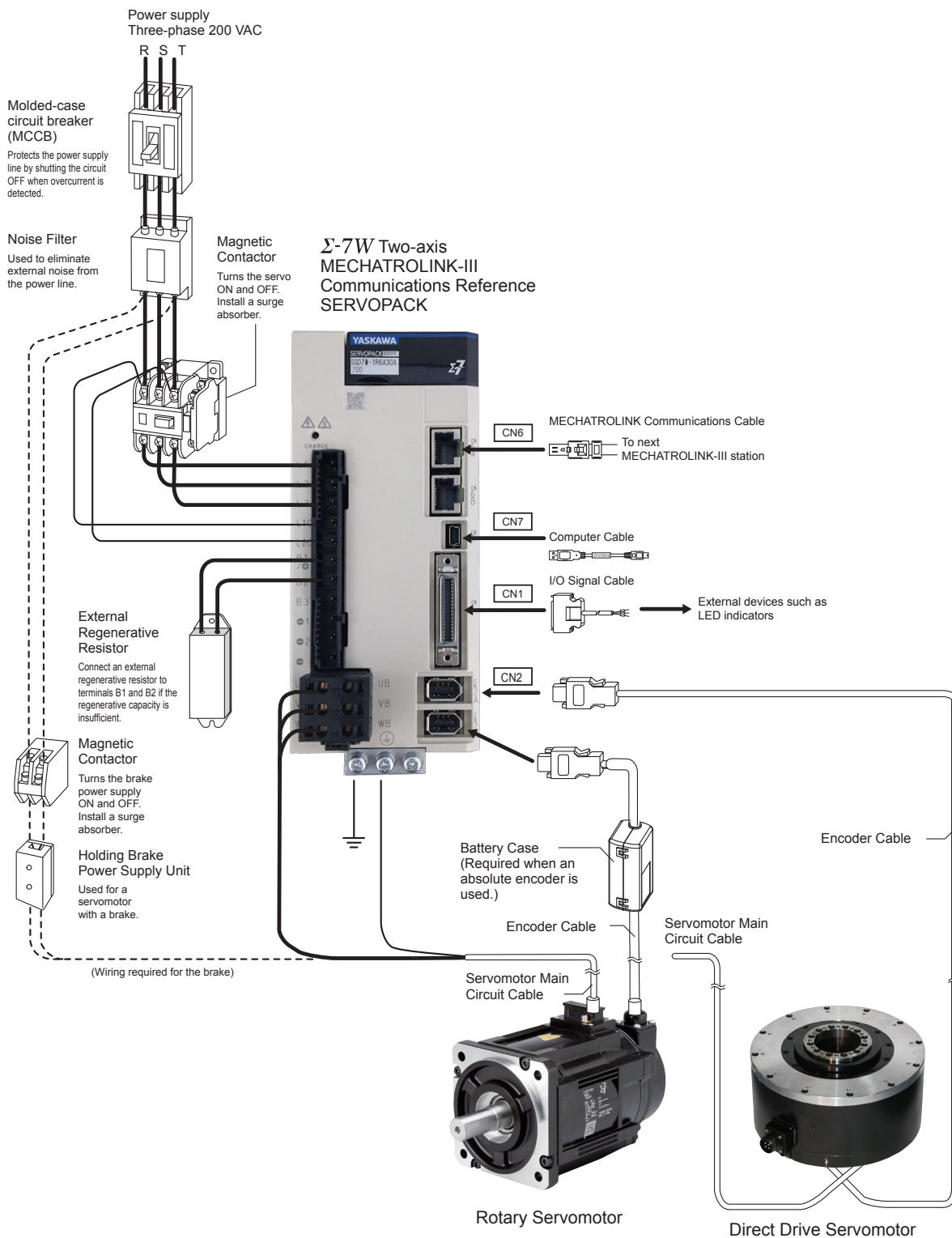

## Stock Status Definitions

The product selection tables in this catalog contain stock status codes, which are subject to change. The codes are defined below:

**S**

### **Stock Item**

Normally 3 to 5 days leadtime for most order quantities. 3 to 5 weeks maximum if temporary outages occur. For critical lead time or large quantity shipments, check with your Yaskawa sales representative.

**LS**

### **Limited Stock Item**

Typically small quantities are available from stock. Items may become stock items as demand increases.

**NS**

### **Non-Stock Item**

Non-stock items typically carry a 12 - 16 week delivery time.



## Σ-7 Series Combination

### ● Combination of Rotary Servomotors and SERVOPACKs

Rotary Servomotor Model		Rated Output	Sigma-7 SERVOPACK Model		Sigma-5 SERVOPACK Model
			SGD7S-□□□□	SGD7W-□□□□	SGDV-□□□□
SGMMV (Low inertia, ultra-small capacity) 6000 RPM	SGMMV-B3E	3.3 W	N/A	N/A	1R7E
	SGMMV-B5E	5.5 W			
	SGMMV-B9E	11 W			
	SGMMV-A1A	10 W	R90A, R90F		2R9E
	SGMMV-A2A	20 W			
SGMMV-A3A	30 W	1R6A, 2R1F			
SGM7J (Medium inertia, high speed) 3000 RPM	SGM7J-A5A	50 W	R70A, R70F	1R6A <sup>*1</sup> , 2R8A <sup>*1</sup>	N/A
	SGM7J-01A	100 W	R90A, R90F		
	SGM7J-C2A	150 W	1R6A, 2R1F		1R9D
	SGM7J-02□	200 W			
	SGM7J-04□	400 W	2R8A, 2R8F	2R8A, 5R5A <sup>*1</sup> , 7R6A <sup>*1</sup>	N/A
	SGM7J-06A	600 W	5R5A	5R5A, 7R6A	3R5D
	SGM7J-08□	750 W			5R4D
	SGM7J-15D	750 W	N/A	N/A	
SGM7A (Low inertia, high speed) 3000 RPM	SGM7A-A5A	50 W	R70A, R70F	1R6A <sup>*1</sup> , 2R8A <sup>*1</sup>	N/A
	SGM7A-01A	100 W	R90A, R90R		
	SGM7A-C2A	150 W	1R6A, 2R1F	1R6A, 2R8A <sup>*1</sup>	1R9D
	SGM7A-02□	200 W			
	SGM7A-04□	400 W	2R8A, 2R8F	2R8A, 5R5A <sup>*1</sup> , 7R6A <sup>*1</sup>	N/A
	SGM7A-06A	600 W	5R5A	5R5A, 7R6A	3R5D
	SGM7A-08□	750 W			5R4D
	SGM7A-10□	1.0 kW	120A		
	SGM7A-15A	1.5 kW	180A		
	SGM7A-20A	2.0 kW	200A		
	SGM7A-25A	2.5 kW			
	SGM7A-30A	3.0 kW			
	SGM7A-40A	4.0 kW	330A		
	SGM7A-50A	5.0 kW			
	SGM7A-70A	7.0 kW	550A		
SGM7P (Medium inertia, flat type) 3000 RPM	SGM7P-01A	100 W	R90A, R90F	1R6A <sup>*1</sup> , 2R8A <sup>*1</sup>	N/A
	SGM7P-02A	200 W	2R8A, 2R8F	2R8A, 5R5A <sup>*1</sup> , 7R6A <sup>*1</sup>	
	SGM7P-04A	400 W			
	SGM7P-08A	750 W	5R5A	5R5A, 7R6A	
	SGM7P-15A	1.5 kW	120A		
SGM7G (Medium inertia, large torque) 1500 min-1	SGM7G-03A	300 W	3R8A	5R5A <sup>*1</sup> , 7R6A <sup>*1</sup>	N/A
	SGM7G-05A	450 W			
	SGM7G-09A	850 W	7R6A	7R6A	
	SGM7G-13A	1.3 kW	120A		
	SGM7G-20A	1.8 kW	180A		
	SGM7G-30A	2.9 kW <sup>*2</sup>	330A		
	SGM7G-44A	4.4 kW			
	SGM7G-55A	5.5 kW	470A		
	SGM7G-75A	7.5 kW	550A		
	SGM7G-1AA	11 kW	590A		
	SGM7G-1EA	15 kW	780A		

\*1. If you use this combination, performance may not be as good, e.g., the control gain may not increase, in comparison with using a Σ-7S SERVOPACK.

\*2. The rated output is 2.4 kW if you combine the SGM7G-30A with the SGD7S-200A.



## Σ-7 Series Combination

### ● Combination of Direct Drive Servomotors and SERVOPACKs

Direct Drive Servomotor Model		Rated Torque Nm	Instantaneous Max. Torque Nm	SERVOPACK Model	
				SGD7S-□□□□	SGD7W-□□□□
SGM7F (With core, inner rotor)	SGM7F-02A	2	6	2R8A, 2R1F	2R8A
	SGM7F-05A	5	15		
	SGM7F-07A	7	21		
	SGM7F-04B	4	12		
	SGM7F-10B	10	30	2R8A, 2R8F	
	SGM7F-14B	14	42		
	SGM7F-08C	8	24	5R5A	
	SGM7F-17C	17	51	2R8A, 2R8F	2R8A
	SGM7F-25C	25	75	5R5A	
	SGM7F-16D	16	48	7R6A	
SGM7F-35D	35	105	5R5A		
Small capacity, coreless (SGMCS)	SGMCS-02B	2	6	7R6A, 120A	7R6A
	SGMCS-05B	5	15		
	SGMCS-07B	7	21		
	SGMCS-04C	4	12		
	SGMCS-10C	10	30		
	SGMCS-14C	14	42		
	SGMCS-08D	8	24		
	SGMCS-17D	17	51		
	SGMCS-25D	25	75	2R8A	
	SGMCS-16E	16	48	5R5A	
SGMCS-35E	35	105	7R6A		
Medium capacity, with core (SGMCS)	SGMCS-45M	45	135	7R6A	
	SGMCS-80M	80	240	120A	-
	SGMCS-80N	80	240		
	SGMCS-1AM	110	330	180A	
	SGMCS-1EN	150	450	200A	
	SGMCS-2ZN	200	600		



## Σ-7 Series Combination

### ● Combination of Linear Servomotors and SERVOPACKs

Linear Servomotor Model		Rated Force N	Max. Force N	SERVOPACK Model	
				SGD7S-□□□□	SGD7W-□□□□
SGLG (Coreless model, with standard magnetic way)	SGLGW-30A050C	12.5	40	R70A	1R6A
	SGLGW-30A080C	25	80	R90A	1R6A
	SGLGW-40A140C	47	140		
	SGLGW-40A253C	93	280	1R6A	
	SGLGW-40A365C	140	420	2R8A	
	SGLGW-60A140C	70	220	1R6A	
	SGLGW-60A253C	140	440	2R8A	
	SGLGW-60A365C	210	660	5R5A	
	SGLGW-90A200C	325	1300	120A	-
SGLGW-90A370C	550	2200	180A		
SGLGW-90A535C	750	3000	200A		
SGLG (Coreless model, with high-force magnetic way)	SGLGW-40A140C	57	230	1R6A	
	SGLGW-40A253C	114	460	2R8A	
	SGLGW-40A365C	171	690	3R8A	5R5A
	SGLGW-60A140C	85	360	1R6A	
	SGLGW-60A253C	170	720	3R8A	5R5A
	SGLGW-60A365C	255	1080	7R6A	
SGLF (Model with F-type iron core)	SGLFW-20A090A	25	86	1R6A	
	SGLFW-20A120A	40	125		
	SGLFW-35A120A	80	220		
	SGLFW-35A230A	160	440	3R8A	5R5A
	SGLFW-50A200B	280	600	5R5A	
	SGLFW-50A380B	560	1200	120A	-
	SGLFW-1ZA200B				
SGLFW-1ZA380B	1120	2400	200A		
SGLT (Model with T-type iron core)	SGLTW-20A170A	130	380	3R8A	5R5A
	SGLTW-20A320A	250	760	7R6A	
	SGLTW-20A460A	380	1140	120A	-
	SGLTW-35A170A	220	660	5R5A	
	SGLTW-35A170H	300	600		
	SGLTW-35A320A	440	1320	120A	-
	SGLTW-35A320H	600	1200		
	SGLTW-35A460A	670	2000	180A	-
	SGLTW-40A400B	670	2600		
	SGLTW-40A600B	1000	4000	330A	-
	SGLTW-50A170H	450	900	5R5A	
	SGLTW-50A320H	900	1800	120A	-
	SGLTW-80A400B	1300	5000	330A	
SGLTW-80A600B	2000	7500	550A		

# Recommended Encoders

## ● Incremental Linear Encoders

✓ : Possible

Output Signal	Manufacturer	Linear Encoder Type	Model			Linear Encoder Pitch μm	Resolution nm	Maximum Speed <sup>3</sup> m/s	Support for Polarity Sensor Input	Application to Linear Motors	Application to Fully-Closed Loop Control
			Scale	Sensor Head	Interpolator (Serial Converter Unit)						
1 Vp-p Analog Voltage <sup>1</sup>	Heidenhain Corporation	Exposed	LIDA48□		JZDP-D003/-D006 <sup>5</sup>	20	78.1	5	✓	✓	✓
					JZDP-G003/-G006 <sup>5</sup>		4.9	2	✓	✓	–
			LIF48□		JZDP-D003/-D006 <sup>5</sup>	4	15.6	1	✓	✓	✓
					JZDP-G003/-G006 <sup>5</sup>		1.0	0.4	✓	✓	–
	Renishaw plc <sup>4</sup>	Exposed	RGS20	RGH22B	JZDP-D005/-D008 <sup>5</sup>	20	78.1	5	✓	✓	✓
					JZDP-G005/-G008 <sup>5</sup>		4.9	2	✓	✓	–
Encoder for Yaskawa's Serial Interface <sup>2</sup>	Magnascale Co., Ltd.	Exposed	SL7□0	PL101-RY <sup>6</sup>		800	97.7	5	–	✓	✓
				PL101	MJ620-T13 <sup>7</sup>				✓	✓	–
		Sealed	SR75-□□□□LF	–	80	9.8	3.33	–	✓	✓	
			SR75-□□□□MF	–	80	78.1	3.33	–	✓	✓	
			SR85-□□□□LF	–	80	9.8	3.33	–	✓	✓	
			SR85-□□□□MF	–	80	78.1	3.33	–	✓	✓	

## ● Absolute Linear Encoder

✓ : Possible

Output Signal	Manufacturer	Linear Encoder Type	Model			Linear Encoder Pitch μm	Resolution nm	Maximum Speed <sup>3</sup> m/s	Support for Polarity Sensor Input	Application to Linear Motors	Application to Fully-Closed Loop Control
			Scale	Sensor Head	Interpolator (Serial Converter Unit)						
Encoder for Yaskawa's Serial Interface <sup>2</sup>	Magnascale Co., Ltd.	Sealed	SR77-□□□□LF	–	–	80	9.8	3.33	–	✓	✓
			SR77-□□□□MF	–	–	80	78.1	3.33	–	✓	✓
			SR87-□□□□LF	–	–	80	9.8	3.33	–	✓	✓
			SR87-□□□□MF	–	–	80	78.1	3.33	–	✓	✓
	Mitutoyo Corporation	Exposed	ST781A	–	–	256	500	5	–	✓	✓
			ST782A	–	–	256	500	5	–	✓	✓
			ST783A	–	–	51.2	100	5	–	✓	✓
			ST784A	–	–	51.2	100	5	–	✓	✓
			ST788A	–	–	51.2	100	5	–	✓	✓
	ST789A <sup>9</sup>	–	–	25.6	50	5	–	✓	✓		
	Heidenhain Corporation	Exposed	LIC4100 series	–	EIB3391Y	–	5	5	–	✓	✓

\*1. You must also use a Yaskawa Serial Converter Unit. The output signal will be multiplied by 8 bits (256 divisions) or 12 bits (4,096 divisions) in the Serial Converter Unit.

\*2. The multiplier (number of divisions) depends on the Linear Encoder. Also, you must write the motor constant file to the Linear Encoder in advance.

\*3. The maximum speeds given in the above table are the maximum applicable speeds of the encoders when combined with a Yaskawa SERVOPACK.

The actual speed will be restricted by either the maximum speed of the Linear Servomotor or the maximum speed of the Linear Encoder (given above).

\*4. If you use the origin signals with a Linear Encoder from Renishaw plc, the origin may sometimes be falsely detected. If that occurs, use the BID/DIR signal to output the origin signal only in one direction.

\*5. Use this model number to purchase the Serial Converter Unit.

\*6. Contact Magnascale Corporation for details on linear motors.

\*7. Contact Magnascale Corporation for details on linear motors.

\*8. Contact your Yaskawa representative.

\*9. Contact Mitutoyo Corporation for details on the Linear Encoders.

Note: Confirm detailed specifications, such as the tolerances, dimensions, and operating environment, with the manufacturer of the Encoder before you use it.

## ● Absolute Rotary Encoder

Output Signal	Manufacturer	Linear Encoder Type	Model			Resolution Bits	Maximum Speed* min-1
			Scale	Sensor Head	Interpolator (Serial Converter Unit)		
Encoder for Yaskawa's Serial Interface	Magnascale Co., Ltd.	Sealed	RU77-4096ADF			20	2000
			RU77-4096AFFT01			22	2000

\*. The maximum speeds given in the above table are the maximum applicable speeds of the encoders when combined with a Yaskawa SERVOPACK.

The actual speed will be restricted by either the maximum speed of the Linear Servomotor or the maximum speed of the Linear Encoder (given above).

Note: Confirm detailed specifications, such as the tolerances, dimensions, and operating environment, with the manufacturer of the Encoder before you use it.



## Related Documents

The documents that are related to the MP3300 Machine Controllers and  $\Sigma$ -7 series AC Servo Drives are shown in the following table. Refer to these documents as required.

Brochure/Catalog Name (Document No.)	Manual Name (Manual No.)	Description of Document
Yaskawa Motion Product Brochure: Confident, Consistent, Capable (BL.MTN.01)	–	This brochure presents an introduction to Yaskawa America Motion Products and services, with an emphasis on AC Servo, Machine Controller, and IO products.
	MP3300iec Machine Controller Hardware Manual (YAI-SIA-IEC-7)	Provides detailed information on selection and installation MP3300iec machine controller components/accessories.
$\Sigma$ -7 Series AC Servo Drives and Motors Technical Supplement (YAI-KAEPS80000123)	$\Sigma$ -7S SERVOPACK with MECHATROLINK-III Communications References Product Manual (SIEPS80000128)	Provides detailed information on selecting $\Sigma$ -7-Series SERVOPACKs and information on installing, connecting, setting, performing trial operation for, tuning, and monitoring the Servo Drives.
	$\Sigma$ -7S SERVOPACK with Analog Voltage/Pulse Train References Product Manual (SIEPS80000126)	
	$\Sigma$ -7S SERVOPACK with EtherCAT (CoE) Communication References Product Manual (SIEPS80000155)	
	$\Sigma$ -7W SERVOPACK with MECHATROLINK-III Communications References Product Manual (SIEPS80000129)	
	$\Sigma$ -V -Series/ $\Sigma$ -V -Series for Large- Capacity Models/ $\Sigma$ -7-Series User's Manual Safety Module (SIEPC72082906)	Provides details information required for the design and maintenance of a Safety Module.
	Rotary Servomotor Product Manual (SIEPS80000136)	Provide detailed information on selecting, installing, and connecting the $\Sigma$ -7-Series Servomotors.
	Linear Servomotor Product Manual (SIEPS80000137)	
	Direct Drive Servomotor Product Manual (SIEPS80000138)	
	Peripheral Device Selection Manual (SIEPS80000132)	Describes the peripheral devices for a $\Sigma$ -7-Series Servo System.
	MECHATROLINK-III Communications Standard Servo Profile Command Manual (SIEPS80000131)	Provides detailed information on the MECHATROLINK-III communications standard servo profile commands that are used for a $\Sigma$ -7- Series Servo System.
Digital Operator Operating Manual (SIEPS80000133)	Describes the operating procedures for a Digital Operator for a $\Sigma$ -7-Series Servo System.	
Engineering Tool SigmaWin+ Online Manual $\Sigma$ -7 Component (SIEPS80000148)	Provides detailed operating procedures for the SigmaWin+ Engineering Tool for a $\Sigma$ -7-Series Servo System.	



# CONTENTS

<b>Rotary Servo Motors</b>	
SGMMV	4
SGM7J	18
SGM7A	48
SGM7P	90
SGM7G	108
<b>Direct Drive Servo Motors</b>	
SGM7F (With Core, Inner Rotor)	136
SGMCS (Small Capacity, Coreless or Medium Capacity, with Core)	152
<b>Linear Servo Motors</b>	
SGLG (Coreless Models)	178
SGLF (Models with F-type Iron Cores)	209
SGLT (Models with T-type Iron Cores)	234
Serial Converter Units	264
Recommended Linear Encoders	266
<b>SERVOPACKs</b>	
$\Sigma$ -7S Single-axis Analog Voltage/Pulse Train Reference SERVOPACKs	278
$\Sigma$ -7S Single-axis MECHATROLINK-III Communications Reference SERVOPACKs	288
$\Sigma$ -7S Single-axis EtherCAT Communications Reference SERVOPACKs	298
$\Sigma$ -7W Two-axis MECHATROLINK-III Communications Reference SERVOPACKs	308
SERVOPACK External Dimensions	316
<b>Option Modules</b>	
Feedback Option Module	326
Safety Option Module	332
Sigma-7Siec Option	336
MP2600iec Option	338
SigmaLogic7 Compact Option	344
FT19 Option - Less Deviation Control	348
FY79 Option - Built-in Indexer	350
FT81 Option - Support for Harmonic Drive SHA Series Actuators	352
<b>Cables and Peripheral Devices</b>	
Cables for SERVOPACKs	356
Peripheral Devices	364

## Appendices

Capacity Selection for Servo Motors	392
Capacity Selection for Regenerative Resistors	402
International Standards	418
Warranty	420

# Rotary Servo Motors

---

SGMMV .....	4
SGM7J .....	18
SGM7A .....	48
SGM7P .....	90
SGM7G .....	108

# SGMMV

## Model Designations

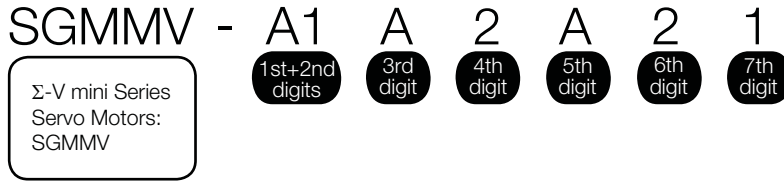

**1st+2nd digits** Rated Output

Code	Specification
A1	10 W
A2	20 W
A3	30 W

**3rd digit** Power Supply Voltage

Code	Specification
A	200 VAC

**4th digit** Serial Encoder

Code	Specification
2	17-bit absolute

**5th digit** Design Revision Order

A

**6th digit** Shaft End

Code	Specification
2	Straight
A	Straight with flat seats

**7th digit** Options

Code	Specification
1	Without options
C	With holding brake (24 VDC)

■ Non Stock Items



## Specifications and Ratings

### Specifications

Voltage		200 V		
Model SGMMV-		A1A	A2A	A3A
Time Rating		Continuous		
Thermal Class		B		
Insulation Resistance		500 VDC, 10 MΩmin.		
Withstand Voltage		1,500 VAC for 1 minute		
Excitation		Permanent magnet		
Mounting		Flange-mounted		
Drive Method		Direct drive		
Rotation Direction		Counterclockwise (CCW) for forward reference when viewed from the load side		
Vibration Class*1		V15		
Environmental Conditions	Surrounding Air Temperature	0°C to 40°C		
	Surrounding Air Humidity	20% to 80% relative humidity (with no condensation)		
	Installation Site	<ul style="list-style-type: none"> <li>• Must be indoors and free of corrosive and explosive gases.</li> <li>• Must be well-ventilated and free of dust and moisture.</li> <li>• Must facilitate inspection and cleaning.</li> <li>• Must have an altitude of 1,000 m or less.</li> <li>• Must be free of strong magnetic fields.</li> </ul>		
	Storage Environment	Store the Servo Motor in the following environment if you store it with the power cable disconnected. Storage Temperature: -20°C to 60°C (with no freezing) Storage Humidity: 20% to 80% relative humidity (with no condensation)		
Shock Resistance*2	Impact Acceleration Rate at Flange	490 m/s <sup>2</sup>		
	Number of Impacts	2 times		
Vibration Resistance*3	Vibration Acceleration Rate at Flange	49 m/s <sup>2</sup>		
Applicable SERVOPACKs	SGD7S-	R90A, R90F		1R6A, 2R1F
	SGD7W-	1R6A*4, 2R8A*4		1R6A, 2R8A*4

\*1. A vibration class of V15 indicates a vibration amplitude of 15 μm maximum on the Servo Motor without a load at the rated motor speed.

\*2. The shock resistance for shock in the vertical direction when the Servo Motor is mounted with the shaft in a horizontal position is given in the above table.

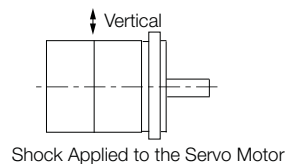

## Rotary Servo Motors

### SGMMV

---

- \*3. The vertical, side-to-side, and front-to-back vibration resistance for vibration in three directions when the Servo Motor is mounted with the shaft in a horizontal position is given in the above table. The strength of the vibration that the Servo Motor can withstand depends on the application. Always check the vibration acceleration rate that is applied to the Servo Motor with the actual equipment.

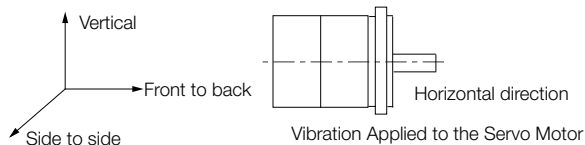

- \*4. If you use a S-7W SERVOPACK, the control gain may not increase as much as with a S-7S SERVOPACK and other performances may be lower than those achieved with a S-7S SERVOPACK.

## Servo Motor Ratings

Voltage		200 V			
Model SGMMV-		A1A	A2A	A3A	
Rated Output <sup>*1</sup>	W	10	20	30	
Rated Torque <sup>*1, *2</sup>	N•m	0.0318	0.0637	0.0955	
Instantaneous Maximum Torque <sup>*1</sup>	N•m	0.0955	0.191	0.286	
Rated Current <sup>*1</sup>	Arms	0.70	0.66	0.98	
Instantaneous Maximum Current <sup>*1</sup>	Arms	2.0	1.9	2.9	
Rated Motor Speed <sup>*1</sup>	min <sup>-1</sup>	3000			
Maximum Motor Speed <sup>*1</sup>	min <sup>-1</sup>	6000			
Torque Constant	N•m/Arms	0.0516	0.107		
Motor Moment of Inertia	×10 <sup>-7</sup> kg•m <sup>2</sup>	2.72 (4.07)	4.66 (6.02)	6.68 (8.04)	
Rated Power Rate <sup>*1</sup>	kW/s	3.72	8.71	13.7	
Rated Angular Acceleration Rate <sup>*1</sup>	rad/s <sup>2</sup>	117000	137000	143000	
Heat Sink Size (Aluminum)	mm	150 x 50 x 3	250 x 250 x 6		
Protective Structure <sup>*3</sup>		Totally enclosed, self-cooled, IP55 (except for shaft opening)			
Holding Brake Specifications <sup>*4</sup>	Rated Voltage	V	24 VDC <sup>+10%</sup> <sub>0</sub>		
	Capacity	W	2.0	2.6	
	Holding Torque	N•m	0.0318	0.0637	0.0955
	Coil Resistance	Ω (at 20°C)	320	221.5	
	Rated Current	A (at 20°C)	0.075	0.108	
	Time Required to Release Brake	ms	40		
	Time Required to Brake	ms	100		
Allowable Load Moment of Inertia (Motor Moment of Inertia Ratio)		30 times			
	With External Regenerative Resistor and Dynamic Brake Resistor	30 times			
Allowable Shaft Loads <sup>*5</sup>	LF	mm	16		
	Allowable Radial Load	N	34	44	
	Allowable Thrust Load	N	14.5		

\*1. These values are for operation in combination with a SERVOPACK when the temperature of the armature winding is 20°C. These are typical values.

\*2. The rated torques are the continuous allowable torque values with an aluminum or steel heat sink of the dimensions given in the table.

\*3. This does not apply to the shaft opening. Protective structure specifications apply only when the special cable is used.

\*4. Observe the following precautions if you use a Servo Motor with a Holding Brake.

- The holding brake cannot be used to stop the Servo Motor.
- The time required to release the brake and the time required to brake depend on which discharge circuit is used. Confirm that the operation delay time is appropriate for the actual equipment.
- The 24-VDC power supply is not provided by Yaskawa.

\*5. The allowable shaft loads are illustrated in the following figure. Design the mechanical system so that the thrust and radial loads applied to the Servo Motor shaft end during operation do not exceed the values given in the table.

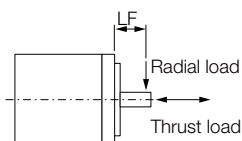

Note: The values in parentheses are for Servo Motors with Holding Brakes.

## Torque-Motor Speed Characteristics

- A** : Continuous duty zone
- B** : Intermittent duty zone\*

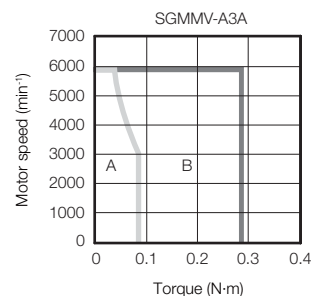
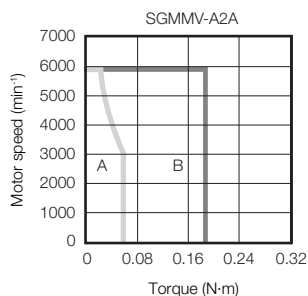
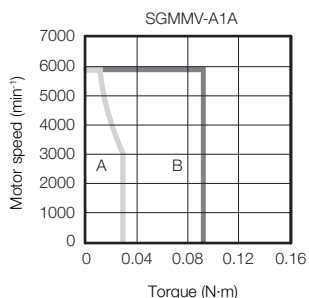

\* The characteristics are the same for three-phase 200 V, single-phase 200 V, and single-phase 100 V input.

Note: 1. These values are for operation in combination with a SERVOPACK when the temperature of the armature winding is 20°C. These are typical values.

2. The characteristics in the intermittent duty zone depend on the power supply voltage.
3. If the effective torque is within the allowable range for the rated torque, the Servo Motor can be used within the intermittent duty zone.
4. If you use a Servo Motor Main Circuit Cable that exceeds 20 m, the intermittent duty zone in the torque-motor speed characteristics will become smaller because the voltage drop increases.

## Servo Motor Overload Protection Characteristics

The overload detection level is set for hot start conditions with a Servo Motor surrounding air temperature of 40°C.

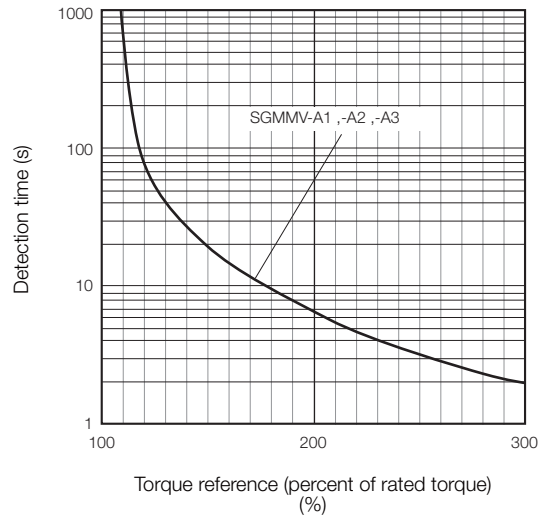

Note: The above overload protection characteristics do not mean that you can perform continuous duty operation with an output of 100% or higher. Use the Servo Motor so that the effective torque remains within the continuous duty zone given in *Torque-Motor Speed Characteristics* (page 8).

## Load Moment of Inertia

The load moment of inertia indicates the inertia of the load. The larger the load moment of inertia, the worse the response. If the moment of inertia is too large, operation will become unstable.

The allowable size of the load moment of inertia ( $J_L$ ) for the Servo Motor is restricted. Refer to *Servo Motor Ratings* (page 7). This value is provided strictly as a guideline and results depend on Servo Motor driving conditions.

An Overvoltage Alarm (A.400) is likely to occur during deceleration if the load moment of inertia exceeds the allowable load moment of inertia. SERVOPACKs with a built-in regenerative resistor may generate a Regenerative Overload Alarm (A.320). Perform one of the following steps if this occurs.

- Reduce the torque limit.
- Reduce the deceleration rate.
- Reduce the maximum motor speed.
- Install an External Regenerative Resistor if the alarm cannot be cleared using the above steps.

Regenerative resistors are not built into SERVOPACKs for 400-W Servo Motors or smaller Servo Motors. Even for SERVOPACKs with built-in regenerative resistors, an External Regenerative Resistor is required if the energy that results from the regenerative driving conditions exceeds the allowable loss capacity (W) of the built-in regenerative resistor.

## Allowable Load Moment of Inertia Scaling Factor for SERVOPACKs without Built-in Regenerative Resistors

The following graphs show the allowable load moment of inertia scaling factor of the motor speed for SERVOPACKs\* without built-in regenerative resistors when an External Regenerative Resistor is not connected.

If the Servo Motor exceeds the allowable load moment of inertia, an overvoltage alarm may occur in the SERVOPACK.

These graphs provide reference data for deceleration at the rated torque or higher.

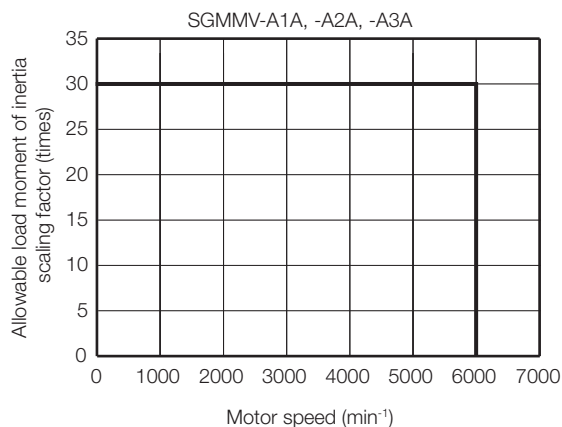

\* Applicable SERVOPACK models: SGD7S-R90A, -1R6A, -R90F, and -2R1F

## Servo Motor Heat Dissipation Conditions

The Servo Motor ratings are the continuous allowable values when a heat sink is installed on the Servo Motor. If the Servo Motor is mounted on a small device component, the Servo Motor temperature may rise considerably because the surface for heat dissipation becomes smaller. Refer to the following graphs for the relation between the heat sink size and derating rate.

When using Servo Motors with derating, change the detection timing of overload warnings and overload alarms by referring to the motor overload detection level described in the following manual.

📖 *Σ-7-Series AC Servo Drive Rotary Servo Motor Product Manual* (Manual No.: S1EP S800001 36)

Note: The derating rates are applicable only when the average motor speed is less than or equal to the rated motor speed.  
If the average motor speed exceeds the rated motor speed, consult with your Yaskawa representative.



Important

The actual temperature rise depends on how the heat sink (i.e., the Servo Motor mounting section) is attached to the installation surface, what material is used for the Servo Motor mounting section, and the motor speed. Always check the Servo Motor temperature with the actual equipment.

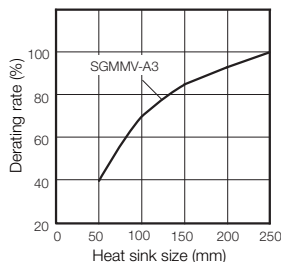
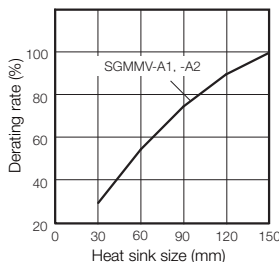

## External Dimensions

### Servo Motors without Holding Brakes

#### ◆ SGMMV-A1, -A2 and -A3

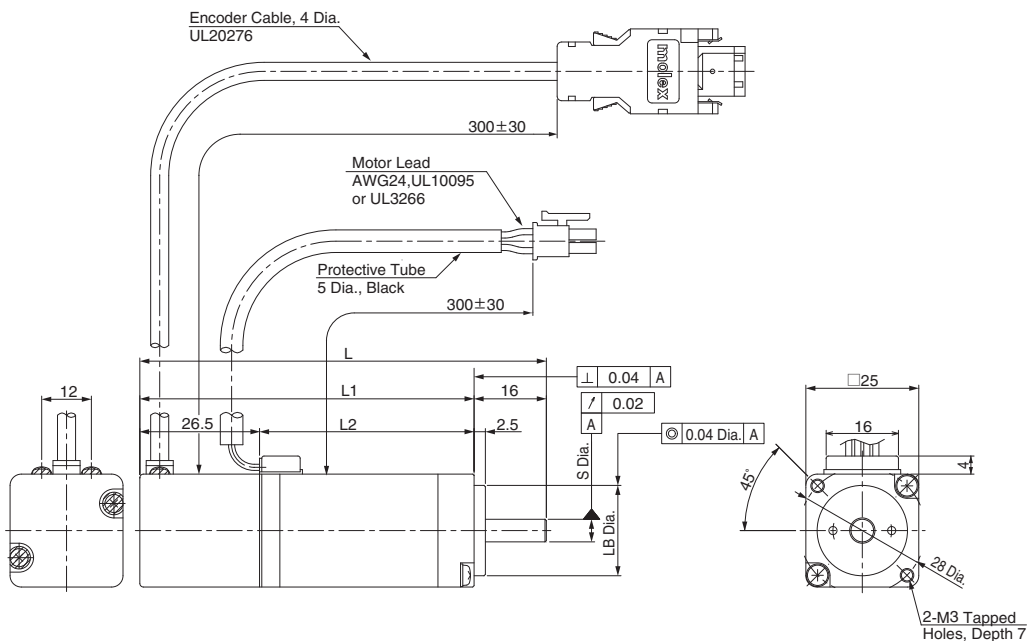

Model SGMMV-	L	L1	L2	Flange Dimensions		Approx. Mass [kg]
				S	LB	
A1A2A□1	70	54	27.5	5 <sup>0</sup> <sub>-0.008</sub>	20 <sup>0</sup> <sub>-0.021</sub>	0.13
A2A2A□1	80	64	37.5	5 <sup>0</sup> <sub>-0.008</sub>	20 <sup>0</sup> <sub>-0.021</sub>	0.17
A3A2A□1	90	74	47.5	5 <sup>0</sup> <sub>-0.008</sub>	20 <sup>0</sup> <sub>-0.021</sub>	0.21

Refer to the following section for information on connectors.

◆ SGMMV-A1, -A2, and -A3 without Holding Brakes (page 14)

#### ■ Shaft End Specification

- Straight with Flat Seats

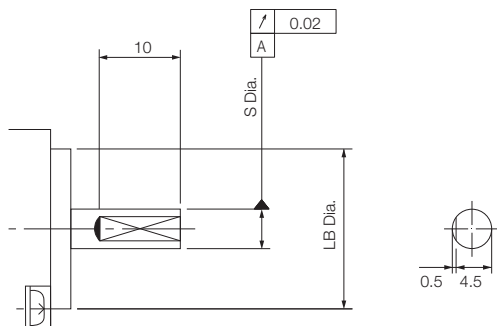



## Servo Motors with Holding Brakes

### ◆ SGMMV-A1, -A2 and -A3

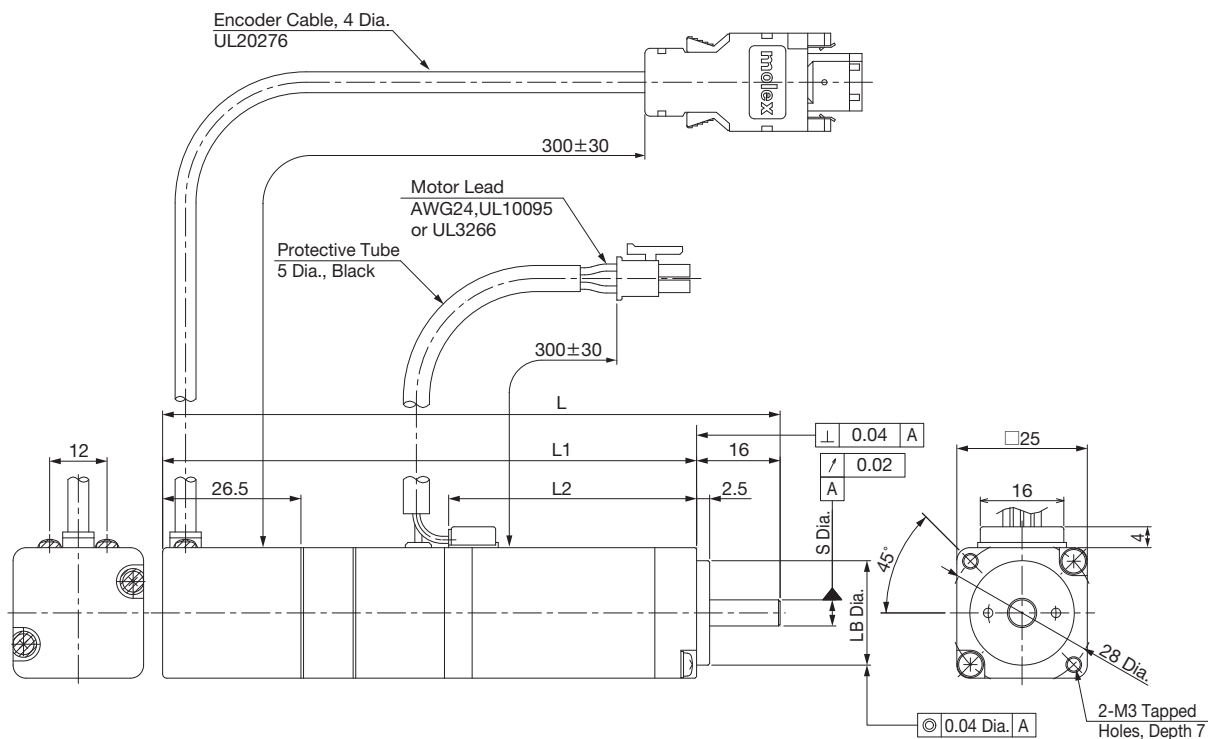

Model SGMMV-	L	L1	L2	Flange Dimensions		Approx. Mass [kg]
				S	LB	
A1A2A□C	94.5	78.5	27.5	5 <sup>U</sup> <sub>-0.01</sub>	20 <sup>U</sup> <sub>-0.02</sub>	0.215
A2A2A□C	108.5	92.5	37.5	5 <sup>U</sup> <sub>-0.01</sub>	20 <sup>U</sup> <sub>-0.02</sub>	0.27
A3A2A□C	118.5	102.5	47.5	5 <sup>U</sup> <sub>-0.01</sub>	20 <sup>U</sup> <sub>-0.02</sub>	0.31

Refer to the following section for information on connectors.

👉 ◆ SGMMV-A1, -A2, and -A3 with Holding Brakes (page 14)

### ■ Shaft End Specification

- Straight with Flat Seats

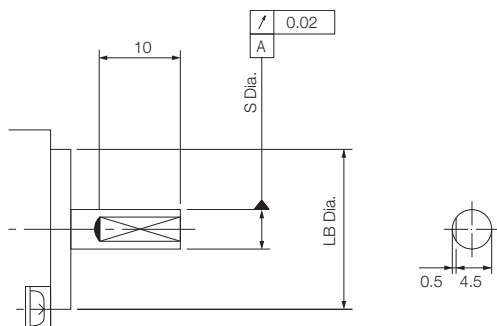

## Connector Specifications

### ◆ SGMMV-A1, -A2, and -A3 without Holding Brakes

- Encoder Connector Specifications

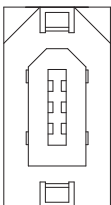

Model: 55102-0600  
Manufacturer: Molex Japan LLC

Mating connector: 54280-0609

- Servo Motor Connector Specifications

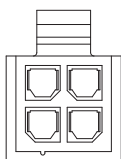

Receptacle: 43025-0400  
Manufacturer: Molex Japan LLC

### ◆ SGMMV-A1, -A2, and -A3 with Holding Brakes

- Encoder Connector Specifications (24-bit Encoder)

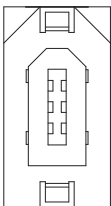

Model: 55102-0600  
Manufacturer: Molex Japan LLC

Mating connector: 54280-0609

- Servo Motor Connector Specifications

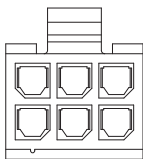

Receptacle: 43025-0600  
Manufacturer: Molex Japan LLC

## Selecting Cables

### ◆ Cable Configurations

The cables shown below are required to connect a Servo Motor to a SERVOPACK.

Encoder Cable of 20 m or Less

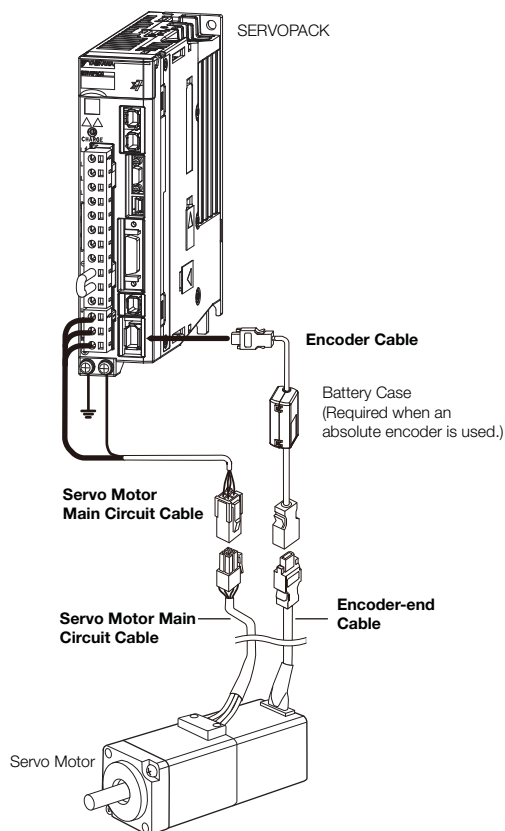

Encoder Cable of 30 m to 50 m (Relay Cable)

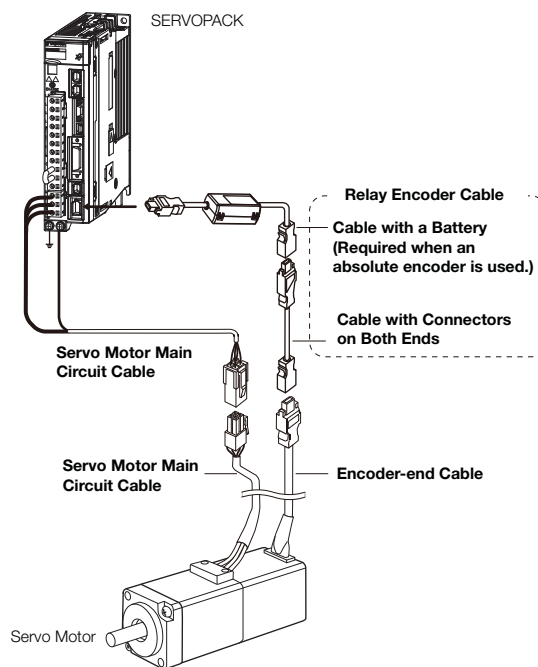

Note: 1. If the cable length exceeds 20 m, be sure to use a Relay Encoder Cable.

2. If you use a Servo Motor Main Circuit Cable that exceeds 20 m, the intermittent duty zone in the torque-motor speed characteristics will become smaller because the voltage drop increases.

3. Refer to the following manual for the following information.

- Cable dimensional drawings and cable connection specifications
- Order numbers and specifications of individual connectors for cables
- Order numbers and specifications for wiring materials

📖 *Σ-7-Series AC Servo Drive Peripheral Device Selection Manual* (Manual No.: SIEP S80001 32)

## Servo Motor Main Circuit Cables

Servo Motor Model	Name	Length (L)	Order Number		Appearance
			Standard Cable	Flexible Cable <sup>*1*2</sup>	
SGMMV -A1, -A2, and -A3  10 W, 20 W, 30 W	For Servo Motors without Holding Brakes	3 m	JZSP-CF2M00-03-E	JZSP-CF2M20-03-E	
		5 m	JZSP-CF2M00-05-E	JZSP-CF2M20-05-E	
		10 m	JZSP-CF2M00-10-E	JZSP-CF2M20-10-E	
		15 m	JZSP-CF2M00-15-E	JZSP-CF2M20-15-E	
		20 m	JZSP-CF2M00-20-E	JZSP-CF2M20-20-E	
		30 m	JZSP-CF2M00-30-E	JZSP-CF2M20-30-E	
		40 m	JZSP-CF2M00-40-E	JZSP-CF2M20-40-E	
		50 m	JZSP-CF2M00-50-E	JZSP-CF2M20-50-E	
	For Servo Motors with Holding Brakes	3 m	JZSP-CF2M03-03-E	JZSP-CF2M23-03-E	
		5 m	JZSP-CF2M03-05-E	JZSP-CF2M23-05-E	
		10 m	JZSP-CF2M03-10-E	JZSP-CF2M23-10-E	
		15 m	JZSP-CF2M03-15-E	JZSP-CF2M23-15-E	
		20 m	JZSP-CF2M03-20-E	JZSP-CF2M23-20-E	
		50 m	JZSP-CF2M03-50-E	JZSP-CF2M23-50-E	

\*1. Use Flexible Cables for moving parts of machines, such as robots.

\*2. The recommended bending radius (R) is 90 mm or larger.

## Encoder Cables of 20 m or Less

Servo Motor Model	Name	Length (L)	Order Number		Appearance
			Standard Cable	Flexible Cable <sup>*1*2</sup>	
All SGMMV models	Cables with Connectors on Both Ends (for incremental encoder)	3 m	JZSP-CMP00-03-E	JZSP-CMP10-03-E	
		5 m	JZSP-CMP00-05-E	JZSP-CMP10-05-E	
		10 m	JZSP-CMP00-10-E	JZSP-CMP10-10-E	
		15 m	JZSP-CMP00-15-E	JZSP-CMP10-15-E	
		20 m	JZSP-CMP00-20-E	JZSP-CMP10-20-E	
	Cables with Connectors on Both Ends (for absolute encoder: With Battery Case)	3 m	JZSP-CSP19-03-E	JZSP-CSP29-03-E	
		5 m	JZSP-CSP19-05-E	JZSP-CSP29-05-E	
		10 m	JZSP-CSP19-10-E	JZSP-CSP29-10-E	
		15 m	JZSP-CSP19-15-E	JZSP-CSP29-15-E	
		20 m	JZSP-CSP19-20-E	JZSP-CSP29-20-E	

\*1. Use Flexible Cables for moving parts of machines, such as robots.

\*2. The recommended bending radius (R) is 68 mm or larger.

## Relay Encoder Cables of 30 m to 50 m

Servo Motor Model	Name	Length (L)	Order Number for Standard Cable	Appearance
All SGMMV models	Cables with Connectors on Both Ends (for incremental or absolute encoder)	30 m	JZSP-UCMP00-30-E	
		40 m	JZSP-UCMP00-40-E	
		50 m	JZSP-UCMP00-50-E	
	Cable with a Battery Case (Required when an absolute encoder is used.)*	0.3 m	JZSP-CSP12-E	

\*This Cable is not required if a battery is connected to the host controller.

# SGM7J

## SGM7J Servo Motors (without Gear Box)

### Model Designations

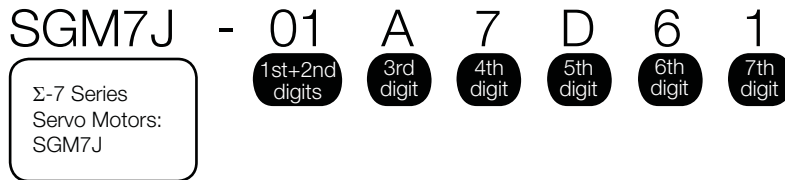

**1st+2nd digits** Rated Output

Code	Specification
A5	50 W
01	100 W
C2	150 W
02	200 W
04	400 W
06	600 W
08	750 W

**3rd digit** Power Supply Voltage

Code	Specification
A	200 VAC
D	400 VAC

**4th digit** Serial Encoder

Code	Specification
7	24-bit absolute
F	24-bit incremental

**5th digit** Design Revision Order

- D: Global design revision (200 V)
- F: Global design revision (400 V)

**6th digit** Shaft End

Code	Specification
2	Straight without key
6	Straight with key and tap
B	With two flat seats

**7th digit** Options

Code	Specification
1	Without options
C	With holding brake (24 VDC)
E	With oil seal and holding brake (24 VDC)
S	With oil seal

■ Non Stock Items

# SGM7J

## SGM7J Gear Motors

The SGM7J gear motor product family pairs SGM7J servo motors with high precision, low backlash inline planetary gear heads resulting in a portfolio of rotary actuators fit for a wide range of applications. The family of gear motors has been thoroughly tested and adheres to the high levels of quality and performance expected from Yaskawa.

The high precision gear heads offer a variety of application advantages:

- ① **Quiet operation** – helical cut gears contribute toward reduced vibration and noise
- ② **High precision** – a standard backlash of 5 arc-min make this gear head ideal for the most accurate applications
- ③ **High rigidity and torque capacity** – achieved with a design which incorporates uncaged needle roller bearings
- ④ **Optimized adapter bushing** – minimizes inertia allowing for more output torque to be realized
- ⑤ **No leakage through the seal** – high viscosity, anti-separation grease does not liquefy and does not migrate away from the gears
- **Maintenance-free** – no need to replace the grease for the life of the unit. The reducer can be positioned in any orientation

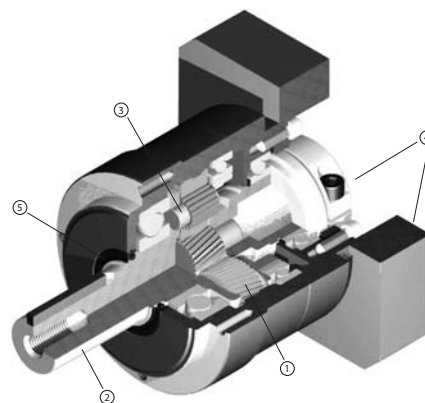

## Model Designations

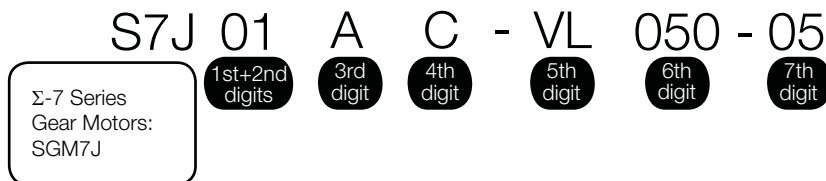

**1st+2nd digits** Rated Output

Code	Specification
01	100 W
02	200 W
04	400 W
08	750 W
15	1.5 kW

**3rd digit** Power Supply Voltage

Code	Specification
A	200 VAC
D	400 VAC

**4th digit** Brake Option

Code	Specification
Blank	No brake
C	24 V Brake

**5th digit** Gear box backlash

Code	Specification
VL	5 arc-min backlash

**6th digit** Gear head frame size

Code	Specification
050	50 mm
070	70 mm
090	90 mm
120	120 mm
155	155 mm

**7th digit** Gear Ratio

Code	Specification
03	3:1 Ratio
05	5:1 Ratio
10	10:1 Ratio
25	25:1 Ratio
50	50:1 Ratio

## Specifications and Ratings

### Specifications (200 V Models)

Voltage		200 VS						
Model SGM7J-		A5A	01A	C2A	02A	04A	06A	08A
Time Rating		Continuous						
Thermal Class		UL: B, CE: B						
Insulation Resistance		500 VDC, 10 MΩmin.						
Withstand Voltage		1,500 VAC for 1 minute						
Excitation		Permanent magnet						
Mounting		Flange-mounted						
Drive Method		Direct drive						
Rotation Direction		Counterclockwise (CCW) for forward reference when viewed from the load side						
Vibration Class <sup>*1</sup>		V15						
Environmental Conditions	Surrounding Air Temperature	0°C to 40°C (With derating, usage is possible between 40°C and 60°C.) <sup>*4</sup>						
	Surrounding Air Humidity	20% to 80% relative humidity (with no condensation)						
	Installation Site	<ul style="list-style-type: none"> <li>• Must be indoors and free of corrosive and explosive gases.</li> <li>• Must be well-ventilated and free of dust and moisture.</li> <li>• Must facilitate inspection and cleaning.</li> <li>• Must have an altitude of 1,000 m or less. (With derating, usage is possible between 1,000 m and 2,000 m.)<sup>*5</sup></li> <li>• Must be free of strong magnetic fields.</li> </ul>						
	Storage Environment	Store the Servo Motor in the following environment if you store it with the power cable disconnected. Storage Temperature: -20°C to 60°C (with no freezing) Storage Humidity: 20% to 80% relative humidity (with no condensation)						
Shock Resistance <sup>*2</sup>	Impact Acceleration Rate at Flange	490 m/s <sup>2</sup>						
	Number of Impacts	2 times						
Vibration Resistance <sup>*3</sup>	Vibration Acceleration Rate at Flange	49 m/s <sup>2</sup>						
Applicable SERVO-PACKs	SGD7S-	R70A	R90A	1R6A	2R8A	5R5A		
	SGD7W-	1R6A <sup>*6</sup> , 2R8A <sup>*6</sup>		1R6A, 2R8A <sup>*6</sup>	2R8A 5R5A <sup>*6</sup> 7R6A <sup>*6</sup>	5R5A, 7R6A		

\*1. A vibration class of V15 indicates a vibration amplitude of 15 μm maximum on the Servo Motor without a load at the rated motor speed.

\*2. The shock resistance for shock in the vertical direction when the Servo Motor is mounted with the shaft in a horizontal position is given in the above table.

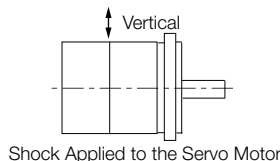



- \*3. The vertical, side-to-side, and front-to-back vibration resistance for vibration in three directions when the Servo Motor is mounted with the shaft in a horizontal position is given in the above table. The strength of the vibration that the Servo Motor can withstand depends on the application. Always check the vibration acceleration rate that is applied to the Servo Motor with the actual equipment.

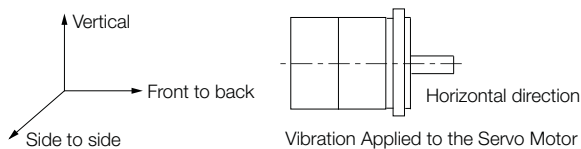

- \*4. If the surrounding air temperature will exceed 40°C, refer to the following section.

■ Applications Where the Surrounding Air Temperature of the Servo Motor Exceeds 40°C (page 31)

- \*5. If the altitude will exceed 1,000 m, refer to the following section.

■ Applications Where the Altitude of the Servo Motor Exceeds 1,000 m (page 32)

- \*6. If you use the Servo Motor together with a S-7W SERVOPACK, the control gain may not increase as much as with a  $\Sigma$ -7S SERVOPACK and other performances may be lower than those achieved with a  $\Sigma$ -7S SERVOPACK.

## Specifications (400 V Models)

Voltage		400 V			
Model SGM7J-		02D	04D	08D	15D
Time Rating		Continuous			
Thermal Class		UL: B, CE: B			
Insulation Resistance		500 VDC, 10 MΩmin.			
Withstand Voltage		1,800 VAC for 1 minute			
Excitation		Permanent magnet			
Mounting		Flange-mounted			
Drive Method		Direct drive			
Rotation Direction		Counterclockwise (CCW) for forward reference when viewed from the load side			
Vibration Class <sup>*1</sup>		V15			
Environmental Conditions	Surrounding Air Temperature	0°C to 40°C (With derating, usage is possible between 40°C and 60°C.) <sup>*4</sup>			
	Surrounding Air Humidity	20% to 80% relative humidity (with no condensation)			
	Installation Site	<ul style="list-style-type: none"> <li>• Must be indoors and free of corrosive and explosive gases.</li> <li>• Must be well-ventilated and free of dust and moisture.</li> <li>• Must facilitate inspection and cleaning.</li> <li>• Must have an altitude of 1,000 m or less. (With derating, usage is possible between 1,000 m and 2,000 m.)<sup>*5</sup></li> <li>• Must be free of strong magnetic fields.</li> </ul>			
	Storage Environment	Store the Servo Motor in the following environment if you store it with the power cable disconnected. Storage Temperature: -20°C to 60°C (with no freezing) Storage Humidity: 20% to 80% relative humidity (with no condensation)			
Shock Resistance <sup>*2</sup>	Impact Acceleration Rate at Flange	490 m/s <sup>2</sup>			
	Number of Impacts	2 times			
Vibration Resistance <sup>*3</sup>	Vibration Acceleration Rate at Flange	49 m/s <sup>2</sup>			
Applicable SERVO-PACKs	SGDV--	1r9		3R5	5R4

\*1. A vibration class of V15 indicates a vibration amplitude of 15 μm maximum on the Servo Motor without a load at the rated motor speed.

\*2. The shock resistance for shock in the vertical direction when the Servo Motor is mounted with the shaft in a horizontal position is given in the above table.

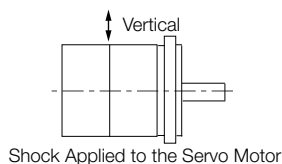

- \*3. The vertical, side-to-side, and front-to-back vibration resistance for vibration in three directions when the Servo Motor is mounted with the shaft in a horizontal position is given in the above table. The strength of the vibration that the Servo Motor can withstand depends on the application. Always check the vibration acceleration rate that is applied to the Servo Motor with the actual equipment.

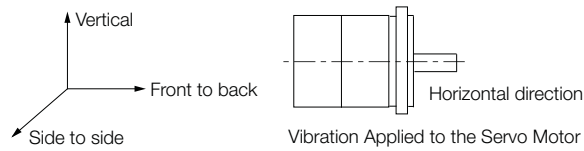

- \*4. If the surrounding air temperature will exceed 40°C, refer to the following section.

■ Applications Where the Surrounding Air Temperature of the Servo Motor Exceeds 40°C (page 31)

- \*5. If the altitude will exceed 1,000 m, refer to the following section.

■ Applications Where the Altitude of the Servo Motor Exceeds 1,000 m (page 32).

## Ratings of Servo Motors (200 V Models)

Voltage		200 V							
Model SGM7J-		A5A	01A	C2A	02A	04A	06A	08A	
Rated Output <sup>*1</sup>	W	50	100	150	200	400	600	750	
Rated Torque <sup>*1, *2</sup>	N•m	0.159	0.318	0.477	0.637	1.27	1.91	2.39	
Instantaneous Maximum Torque <sup>*1</sup>	N•m	0.557	1.11	1.67	2.23	4.46	6.69	8.36	
Rated Current <sup>*1</sup>	Arms	0.55	0.85	1.6	1.6	2.5	4.2	4.4	
Instantaneous Maximum Current <sup>*1</sup>	Arms	2.0	3.1	5.7	5.8	9.3	15.3	16.9	
Rated Motor Speed <sup>*1</sup>	min <sup>-1</sup>	3000							
Maximum Motor Speed <sup>*1</sup>	min <sup>-1</sup>	6000							
Torque Constant	N•m/Arms	0.316	0.413	0.321	0.444	0.544	0.493	0.584	
Motor Moment of Inertia	×10 <sup>-4</sup> kg•m <sup>2</sup>	0.0395 (0.0475)	0.0659 (0.0739)	0.0915 (0.0995)	0.263 (0.333)	0.486 (0.556)	0.800 (0.870)	1.59 (1.77)	
Rated Power Rate <sup>*1</sup>	kW/s	6.40 (5.32)	15.3 (13.6)	24.8 (22.8)	15.4 (12.1)	33.1 (29.0)	45.6 (41.9)	35.9 (32.2)	
Rated Angular Acceleration Rate <sup>*1</sup>	rad/s <sup>2</sup>	40200 (33400)	48200 (43000)	52100 (47900)	24200 (19100)	26100 (22800)	23800 (21900)	15000 (13500)	
Derating Rate for Servo Motor with Oil Seal	%	80	90			95			
Heat Sink Size (Aluminum)	mm	200 × 200 × 6			250 × 250 × 6				
Protective Structure <sup>*3</sup>	Totally enclosed, self-cooled, IP67								
Holding Brake Specifications <sup>*4</sup>	Rated Voltage	V	24 VDC±10%						
	Capacity	W	5.5			6		6.5	
	Holding Torque	N•m	0.159	0.318	0.477	0.637	1.27	1.91	2.39
	Coil Resistance	Ω(at 20°C)	104.8±10%			96±10%		88.6±10%	
	Rated Current	A (at 20°C)	0.23			0.25		0.27	
	Time Required to Release Brake	ms	60					80	
	Time Required to Brake	ms	100						
Allowable Load Moment of Inertia (Motor Moment of Inertia Ratio)			35 times			15 times	10 times	20 times	12 times
Allowable Shaft Loads <sup>*5</sup>	LF	mm	20			25		35	
	Allowable Radial Load	N	78			245		392	
	Allowable Thrust Load	N	54			74		147	

Note: The values in parentheses are for Servo Motors with Holding Brakes.

\*1. These values are for operation in combination with a SERVOPACK when the temperature of the armature winding is 100°C. The values for other items are at 20°C. These are typical values.

\*2. The rated torques are the continuous allowable torque values at a surrounding air temperature of 40°C with an aluminum heat sink of the dimensions given in the table.

\*3. This does not apply to the shaft opening. Protective structure specifications apply only when the special cable is used.

\*4. Observe the following precautions if you use a Servo Motor with a Holding Brake.

- The holding brake cannot be used to stop the Servo Motor.
- The time required to release the brake and the time required to brake depend on which discharge circuit is used. Confirm that the operation delay time is appropriate for the actual equipment.
- The 24-VDC power supply is not provided by Yaskawa.

\*5. The allowable shaft loads are illustrated in the following figure. Design the mechanical system so that the thrust and radial loads applied to the Servo Motor shaft end during operation do not exceed the values given in the table.

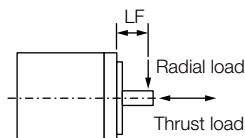

## Ratings of Servo Motors (400 V Models)

Voltage		400 V				
Model SGM7J-		02D	04D	08D	15D	
Rated Output <sup>*1</sup>	W	200	400	750	1500	
Rated Torque <sup>*1, *2</sup>	N•m	0.637	1.27	2.39	4.77	
Instantaneous Maximum Torque <sup>*1</sup>	N•m	2.23	4.46	8.36	14.3	
Rated Current <sup>*1</sup>	Arms	1.5	1.4	2.2	4.5	
Instantaneous Maximum Current <sup>*1</sup>	Arms	5.5	5.3	8.2	14.0	
Rated Motor Speed <sup>*1</sup>	min <sup>-1</sup>	3000				
Maximum Motor Speed <sup>*1</sup>	min <sup>-1</sup>	6000				
Torque Constant	N•m/Arms	0.461	0.965	1.17	1.13	
Motor Moment of Inertia	×10 <sup>-4</sup> kg•m <sup>2</sup>	0.263 (0.333)	0.486 (0.556)	1.59 (1.77)	4.02 (4.90)	
Rated Power Rate <sup>*1</sup>	kW/s	15.4 (12,1)	33.1 (29.0)	35.9 (32.2)	56.6 (46.6)	
Rated Angular Acceleration Rate <sup>*1</sup>	rad/s <sup>2</sup>	24200 (19100)	26100 (22800)	15000 (13500)	11900 (9700)	
Heat Sink Size (Aluminum)	mm	250 × 250 × 6			300 × 300 × 12	
Protective Structure <sup>*3</sup>		Totally enclosed, self-cooled, IP67				
Holding Brake Specifications <sup>*4</sup>	Rated Voltage	V	24 VDC±10%			
	Capacity	W	6.0	6.5	7.5	
	Holding Torque	N•m	0.637	1.27	2.39	4.77
	Coil Resistance	Ω (at 20°C)	96±10%		88.6±10%	76.8±10%
	Rated Current	A (at 20°C)	0.25		0.27	0.31
	Time Required to Release Brake	ms	60		80	
	Time Required to Brake	ms	100			
Allowable Load Moment of Inertia (Motor Moment of Inertia Ratio)		25 times		15 times	12 times	
Allowable Shaft Loads <sup>*5</sup>	LF	mm	25		35	
	Allowable Radial Load	N	245		392	490
	Allowable Thrust Load	N	74		147	

Note: The values in parentheses are for Servo Motors with Holding Brakes.

\*1. These values are for operation in combination with a SERVOPACK when the temperature of the armature winding is 100°C. The values for other items are at 20°C. These are typical values.

\*2. The rated torques are the continuous allowable torque values at a surrounding air temperature of 40°C with an aluminum heat sink of the dimensions given in the table.

\*3. This does not apply to the shaft opening. Protective structure specifications apply only when the special cable is used.

\*4. Observe the following precautions if you use a Servo Motor with a Holding Brake.

- The holding brake cannot be used to stop the Servo Motor.
- The time required to release the brake and the time required to brake depend on which discharge circuit is used. Confirm that the operation delay time is appropriate for the actual equipment.
- The 24-VDC power supply is not provided by Yaskawa.

\*5. The allowable shaft loads are illustrated in the following figure. Design the mechanical system so that the thrust and radial loads applied to the Servo Motor shaft end during operation do not exceed the values given in the table.

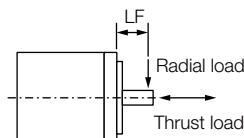

## Servo Motor Torque-Motor Speed Characteristics (200V Models)

A : Continuous duty zone      — (solid lines): With three-phase 200-V or single-phase 230-V input  
B : Intermittent duty zone      - - - (dotted lines): With single-phase 200-V input

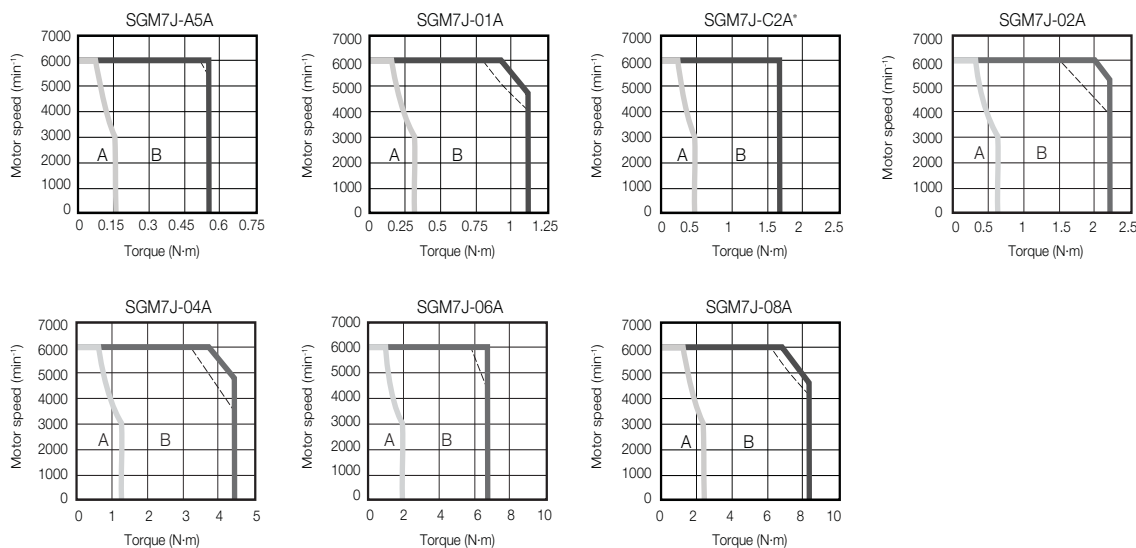

\* The characteristics are the same for three-phase 200 V and single-phase 200 V.

Note: 1. These values are for operation in combination with a SERVOPACK when the temperature of the armature winding is 100°C. These are typical values.

2. The characteristics in the intermittent duty zone depend on the power supply voltage.
3. If the effective torque is within the allowable range for the rated torque, the Servo Motor can be used within the intermittent duty zone.
4. If you use a Servo Motor Main Circuit Cable that exceeds 20 m, the intermittent duty zone in the torque-motor speed characteristics will become smaller because the voltage drop increases.



Important

The SERVOPACK speed control range is 5,000:1. If you use Servo Motors at extremely low speeds ( $0.02 \text{ min}^{-1}$  or lower at the gear output shaft), if you use Servo Motors with a one-pulse feed reference for extended periods, or under some other operating conditions, the gear bearing lubrication may be insufficient. That may cause deterioration of the bearing or increase the load ratio.

Contact your Yaskawa representative if you use a Servo Motor under these conditions.

\* The moment of inertia for the Servo Motor and gear is the value without a holding brake. You can calculate the moment of inertia for a Servo Motor with a Gear and Holding Brake with the following formula.

Motor moment of inertia for a Servo Motor with a Holding Brake from *Ratings of Servo Motors (200 V Models)* (page 24) + Moment of inertia for the gear from the above table.

## Ratings of Gear Motors (200 V Models)

Gear Motor Model Number	Base Servo Motor Model (SGM7J-)	Gear Ratio	Gearing Efficiency *1	Rated Speed (RPM)	Max Speed (RPM)	Rated Torque (Nm) <sup>*2</sup>	Peak Torque (Nm) <sup>*2</sup>	Motor Inertia (x10 <sup>-4</sup> kg-m <sup>2</sup> )	Gear-head Inertia (x10 <sup>-4</sup> kg-m <sup>2</sup> )	Allowable Radial Load (N)	Allowable Axial Load (N)	Backlash (arc-min)	Protection Class	
S7J01A□ -VL050-03	01A7D6□	3:1	95	1000	2000	0.906	3.16	0.0659 (0.0739)	0.053	710	640	5	IP65	
S7J01A□ -VL050-05		5:1		600	1200	1.51	5.27		0.036					
S7J01A□ -VL050-10		10:1		300	600	3.02	10.5		0.030					
S7J01A□ -VL050-25		25:1	90	120	240	7.16	18.0 <sup>*3</sup>		0.034	1200	1100	5		
S7J01A□ -VL070-50		50:1		60	120	14.3	50.0		0.030					
S7J02A□ -VL050-03	02A7D6□	3:1	95	1000	2000	1.82	6.36	0.2630 (0.3330)	0.091	710	640	5		
S7J02A□ -VL050-05		5:1		600	1200	3.03	10.6		0.074					
S7J02A□ -VL050-10		10:1		300	600	6.05	12.0 <sup>*3</sup>		0.140					1200
S7J02A□ -VL070-25		25:1	90	120	240	14.3	50.2		0.130					
S7J02A□ -VL070-50		50:1		60	120	28.7	50.0 <sup>*3</sup>		0.130					
S7J04A□ -VL050-03	04A7D6□	3:1	95	1000	2000	3.62	12.7	0.4860 (0.5560)	0.091	710	640			5
S7J04A□ -VL050-05		5:1		600	1200	6.03	18.0 <sup>*3</sup>		0.074					
S7J04A□ -VL070-10		10:1		300	600	12.1	35.0 <sup>*3</sup>		0.140					
S7J04A□ -VL070-25		25:1	90	120	240	28.6	50.0 <sup>*3</sup>		0.130					
S7J04A□ -VL090-50		50:1		60	120	57.2	125 <sup>*3</sup>		0.250	2400	2200			
S7J08A□ -VL070-03	08A7D6□	3:1	95	1000	2000	6.81	23.8	0.8000 (0.8700)	0.430	1200	1100		5	
S7J08A□ -VL070-05		5:1		600	1200	11.4	39.7		0.360					
S7J08A□ -VL090-10		10:1		300	600	22.7	79.4		0.750					
S7J08A□ -VL090-25		25:1	90	120	240	53.8	125 <sup>*3</sup>		0.710					
S7J08A□ -VL120-50		50:1		60	120	108	330 <sup>*3</sup>		0.730	4300	3900			

Note: The values in parentheses are for Servo Motors with Holding Brakes (indicated by value of □ in model numbers).

\*1. The gear efficiency depends on operating conditions such as the output torque, motor speed, and temperature.

\*2. The gear motor output torque is expressed by the following formula: Output Torque = (Servo Motor Output Torque) x (Gearing Ratio) x (Gearing Efficiency). The values in the table are typical values for the rated torque, rated motor speed, and a surrounding air temperature of 25°C. They are reference values only.

\*3. The output torque of the gear motor is limited by the mechanical limit of the gear head. Operation above this limit could result in premature failure of the gear motor.



Important

During operation of the gear motor, losses due to inefficiencies of the gearing mechanism are generated. The losses vary as the conditions for gear motor torque and speed change. Temperature rise can vary based on the mechanical inefficiencies and the heat dissipation conditions. For heat dissipation conditions, check the gear and motor temperatures with the actual equipment. If operating temperatures are too high, implement the following measures.

- Decrease the load ratio.
- Change the heat dissipation conditions.
- Use forced-air cooling for the motor with a cooling fan or other means.

## Ratings of Gear Motors (400 V Models)

Gear Motor Model Number	Base Servo Motor Model (SGM7J-)	Gear Ratio	Gearing Efficiency *1	Rated Speed (RPM)	Max Speed (RPM)	Rated Torque (Nm) <sup>*2</sup>	Peak Torque (Nm) <sup>*2</sup>	Motor Inertia (x10 <sup>-4</sup> kg-m <sup>2</sup> )	Gear-head Inertia (x10 <sup>-4</sup> kg-m <sup>2</sup> )	Allowable Radial Load (N)	Allowable Axial Load (N)	Backlash (arc-min)	Protection Class
S7J02D□ -VL050-03	02D7F6□	3:1	95	1000	2000	1.82	6.36	0.263 (0.333)	0.091	710	640	5	IP65
S7J02D□ -VL050-05		5:1		600	1200	3.03	10.6		0.074				
S7J02D□ -VL050-10		10:1		300	600	6.05	12.0 <sup>*3</sup>		0.140				
S7J02D□ -VL070-25		25:1	90	120	240	14.3	50.2		0.130				
S7J02D□ -VL070-50		50:1		60	120	28.7	50.0 <sup>*3</sup>		0.130				
S7J04D□ -VL050-03	04D7F6□	3:1	95	1000	2000	3.62	12.7	0.486 (0.556)	0.091	710	640		
S7J04D□ -VL050-05		5:1		600	1200	6.03	18.0 <sup>*3</sup>		0.074				
S7J04D□ -VL070-10		10:1		300	600	12.1	35.0 <sup>*3</sup>		0.140				
S7J04D□ -VL070-25		25:1	90	120	240	28.6	50.0 <sup>*3</sup>		0.130				
S7J04D□ -VL090-50		50:1		60	120	57.2	125 <sup>*3</sup>		0.250	2400	2200		
S7J08D□ -VL070-03	08D7F6□	3:1	95	1000	2000	6.81	23.8	1.59 (1.77)	0.091	1200	1100		
S7J08D□ -VL070-05		5:1		600	1200	11.4	39.7		0.074				
S7J08D□ -VL090-10		10:1		300	600	22.7	79.4		0.140				
S7J08D□ -VL090-25		25:1	90	120	240	53.8	125 <sup>*3</sup>		0.130				
S7J08D□ -VL120-50		50:1		40 <sup>*3</sup>	80 <sup>*3</sup>	108	330 <sup>*3</sup>		0.250	4300	3900		
S7J15D□ -VL090-03	15D7F6□	3:1	95	1000	2000	13.6	40.8	4.02 (4.9)	0.430	2400	2200		
S7J15D□ -VL090-05		5:1		600	1200	22.7	67.9		0.360				
S7J15D□ -VL090-10		10:1		300	600	45.3	80 <sup>*3</sup>		0.750				
S7J15D□ -VL120-25		25:1	90	120	240	107	322		0.710	4300	3900		
S7J15D□ -VL155-50		50:1		40 <sup>*3</sup>	80 <sup>*3</sup>	215	644		0.730	9100	8200		

Note: The values in parentheses are for Servo Motors with Holding Brakes (indicated by value of □ in model numbers).

\*1. The gear efficiency depends on operating conditions such as the output torque, motor speed, and temperature.

\*2. The gear motor output torque is expressed by the following formula: Output Torque = (Servo Motor Output Torque) x (Gearing Ratio) x (Gearing Efficiency). The values in the table are typical values for the rated torque, rated motor speed, and a surrounding air temperature of 25°C. They are reference values only.

\*3. The output torque of the gear motor is limited by the mechanical limit of the gear head. Operation above this limit could result in premature failure of the gear motor.



Important

During operation of the gear motor, losses due to inefficiencies of the gearing mechanism are generated. The losses vary as the conditions for gear motor torque and speed change. Temperature rise can vary based on the mechanical inefficiencies and the heat dissipation conditions. For heat dissipation conditions, check the gear and motor temperatures with the actual equipment. If operating temperatures are too high, implement the following measures.

- Decrease the load ratio.
- Change the heat dissipation conditions.
- Use forced-air cooling for the motor with a cooling fan or other means.



## Servo Motor Overload Protection Characteristics

The overload detection level is set for hot start conditions with a Servo Motor surrounding air temperature of 40°C.

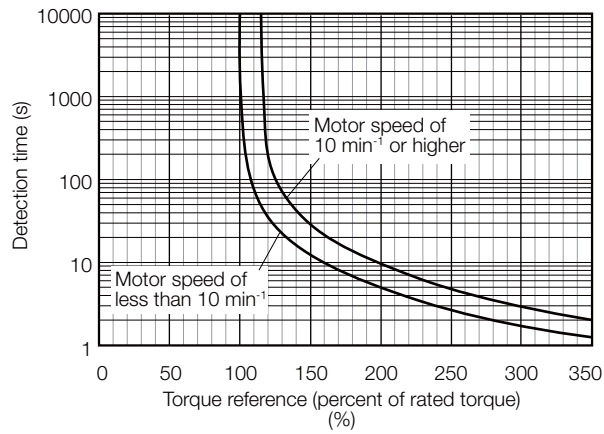

Note: The above overload protection characteristics do not mean that you can perform continuous duty operation with an output of 100% or higher.

Use the Servo Motor so that the effective torque remains within the continuous duty zone given in *Ratings of Servo Motors (400 V Models)* on page 25.

## Allowable Load Moment of Inertia Scaling Factor for SERVOPACKs without Built-in Regenerative Resistors

The following graphs show the allowable load moment of inertia scaling factor of the motor speed for SERVOPACKs\* without built-in regenerative resistors when an External Regenerative Resistor is not connected.

If the Servo Motor exceeds the allowable load moment of inertia, an overvoltage alarm may occur in the SERVOPACK.

These graphs provide reference data for deceleration at the rated torque or higher with a 200-VAC power supply input.

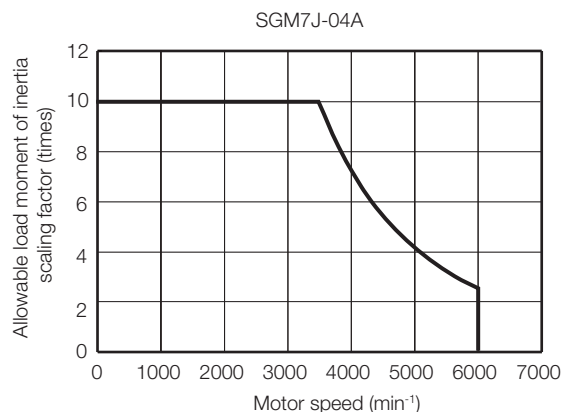
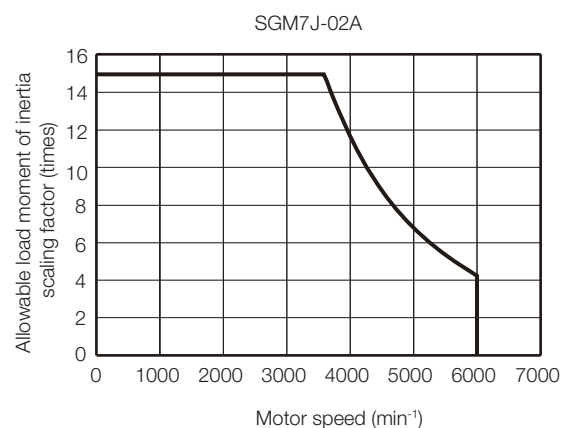
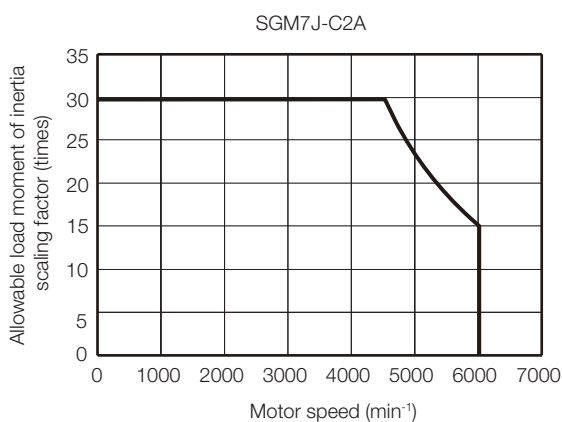
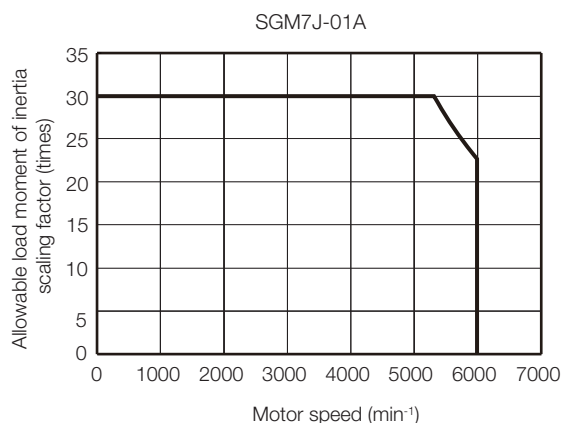
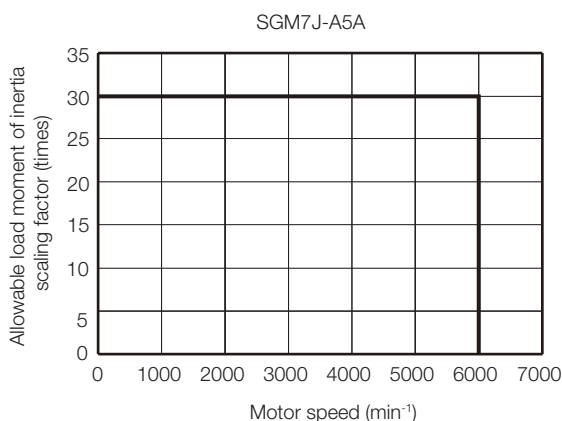

\* Applicable SERVOPACK models: SGD7S-R70A, -R90A, -1R6A, or -2R8A

## Servo Motor Heat Dissipation Conditions

The Servo Motor ratings are the continuous allowable values at a surrounding air temperature of 40°C when a heat sink is installed on the Servo Motor. If the Servo Motor is mounted on a small device component, the Servo Motor temperature may rise considerably because the surface for heat dissipation becomes smaller. Refer to the following graphs for the relation between the heat sink size and derating rate.

When using Servo Motors with derating, change the detection timing of overload warnings and overload alarms by referring to the motor overload detection level described in the following manual.

☞ *Σ-7-Series AC Servo Drive Rotary Servo Motor Product Manual* (Manual No.: SIEP S800001 36)

Note: The derating rates are applicable only when the average motor speed is less than or equal to the rated motor speed. If the average motor speed exceeds the rated motor speed, consult with your Yaskawa representative.



Important

The actual temperature rise depends on how the heat sink (i.e., the Servo Motor mounting section) is attached to the installation surface, what material is used for the Servo Motor mounting section, and the motor speed. Always check the Servo Motor temperature with the actual equipment.

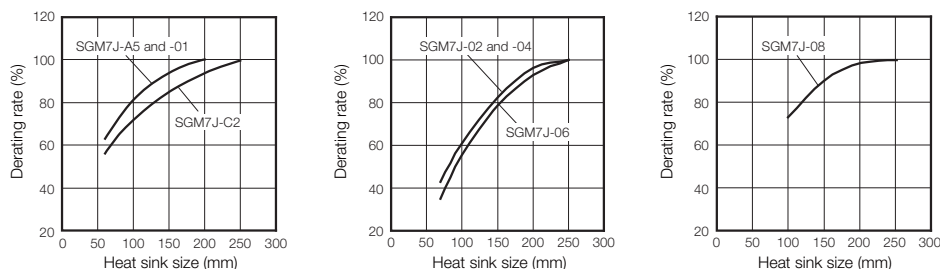

## Applications Where the Surrounding Air Temperature of the Servo Motor Exceeds 40°C

The Servo Motor ratings are the continuous allowable values at a surrounding air temperature of 40°C. If you use a Servo Motor at a surrounding air temperature that exceeds 40°C (60°C max.), apply a suitable derating rate from the following graphs.

When using Servo Motors with derating, change the detection timing of overload warnings and overload alarms by referring to the motor overload detection level described in the following manual.

☞ *Σ-7-Series AC Servo Drive Rotary Servo Motor Product Manual* (Manual No.: SIEP S800001 36)

Note: 1. Use the combination of the SERVOPACK and Servo Motor so that the derating conditions are satisfied for both the SERVOPACK and Servo Motor.

2. The derating rates are applicable only when the average motor speed is less than or equal to the rated motor speed. If the average motor speed exceeds the rated motor speed, consult with your Yaskawa representative.

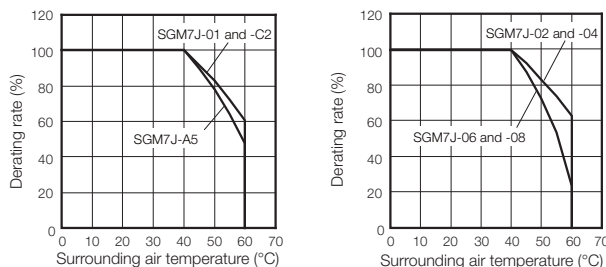

## Applications Where the Altitude of the Servo Motor Exceeds 1,000 m

The Servo Motor ratings are the continuous allowable values at an altitude of 1,000 m or less. If you use a Servo Motor at an altitude that exceeds 1,000 m (2,000 m max.), the heat dissipation effect of the air is reduced. Apply the appropriate derating rate from the following graphs.

When using Servo Motors with derating, change the detection timing of overload warnings and overload alarms by referring to the motor overload detection level described in the following manual.

📖 *Σ-7-Series AC Servo Drive Rotary Servo Motor Product Manual* (Manual No.: SIEP S800001 36)

Note: 1. Use the combination of the SERVOPACK and Servo Motor so that the derating conditions are satisfied for both the SERVOPACK and Servo Motor.

2. The derating rates are applicable only when the average motor speed is less than or equal to the rated motor speed. If the average motor speed exceeds the rated motor speed, consult with your Yaskawa representative.

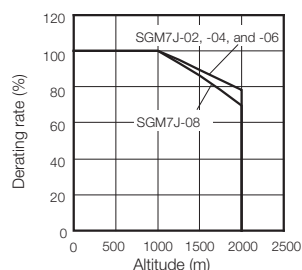
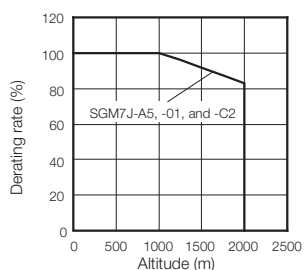

## External Dimensions

### ◆ 200 V Models: SGM7J-A5, -01, and -C2

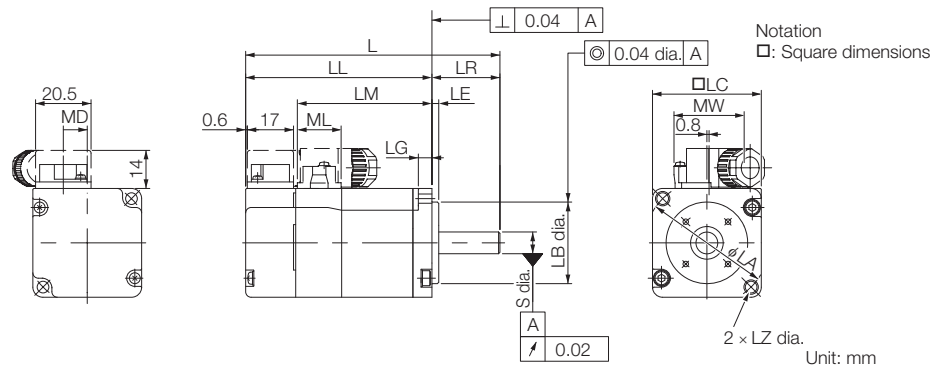

Model SGM7J-	L	LL	LM	Flange Dimensions							S
				LR	LE	LG	LC	LA	LB	LZ	
A5A□A2□	81.5 (122)	56.5 (97)	37.9	25	2.5	5	40	46	30 <sup>0</sup> <sub>-0.021</sub>	4.3	8 <sup>0</sup> <sub>-0.009</sub>
01A□A2□	93.5 (134)	68.5 (109)	49.9	25	2.5	5	40	46	30 <sup>0</sup> <sub>-0.021</sub>	4.3	8 <sup>0</sup> <sub>-0.009</sub>
C2A□A2□	105.5 (153.5)	80.5 (128.5)	61.9	25	2.5	5	40	46	30 <sup>0</sup> <sub>-0.021</sub>	4.3	8 <sup>0</sup> <sub>-0.009</sub>

Model SGM7J-	MD	MW	ML	Approx. Mass [kg]
A5A□A2□	8.8	25.8	16.1	0.3 (0.6)
01A□A2□	8.8	25.8	16.1	0.4 (0.7)
C2A□A2□	8.8	25.8	16.1	0.5 (0.8)

Note: 1. The values in parentheses are for Servo Motors with Holding Brakes.

2. Refer to the following section for detailed shaft end specifications.

👉 400 V Models: SGM7J-02, -04 (page 35)

### ■ Specifications of Options

- Oil Seal

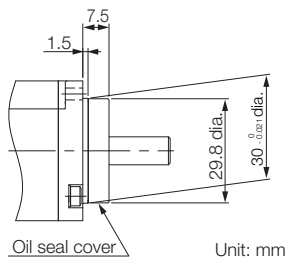

◆ 200 V Models: SGM7J-02, -04, -06, and -08

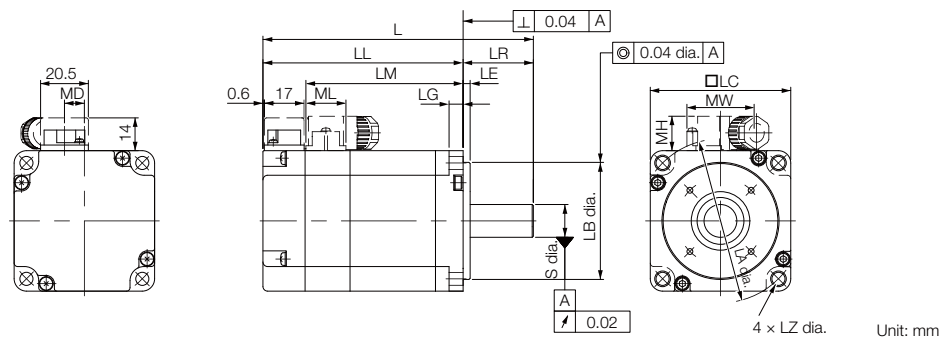

Model SGM7J-	L	LL	LM	Flange Dimensions							S
				LR	LE	LG	LC	LA	LB	LZ	
02A□A2□	99.5 (140)	69.5 (110)	51.2	30	3	6	60	70	50 <sup>0</sup> <sub>-0.025</sub>	5.5	14 <sup>0</sup> <sub>-0.011</sub>
04A□A2□	115.5 (156)	85.5 (126)	67.2	30	3	6	60	70	50 <sup>0</sup> <sub>-0.025</sub>	5.5	14 <sup>0</sup> <sub>-0.011</sub>
06A□A2□	137.5 (191.5)	107.5 (161.5)	89.2	30	3	6	60	70	50 <sup>0</sup> <sub>-0.025</sub>	5.5	14 <sup>0</sup> <sub>-0.011</sub>
08A□A2□	137 (184)	97 (144)	78.5	40	3	8	80	90	70 <sup>0</sup> <sub>-0.030</sub>	7	19 <sup>0</sup> <sub>-0.013</sub>

Model SGM7J-	MD	MW	MH	ML	Approx. Mass [kg]
02A□A2□	8.5	28.7	14.7	17.1	0.8 (1.4)
04A□A2□	8.5	28.7	14.7	17.1	1.1 (1.7)
06A□A2□	8.5	28.7	14.7	17.1	1.6 (2.2)
08A□A2□	13.6	38	14.7	19.3	2.2 (2.8)

Note: 1. The values in parentheses are for Servo Motors with Holding Brakes.

2. Refer to the following section for detailed shaft end specifications.

■ 400 V Models: SGM7J-02, -04 (page 35)

■ Specifications of Options

- Oil Seal

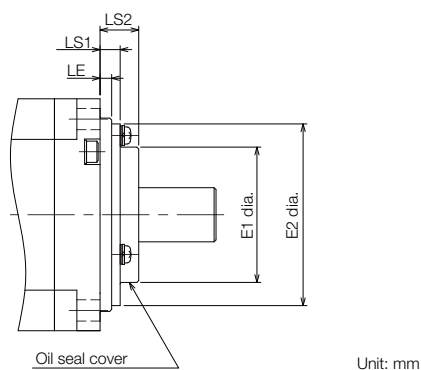

Model SGM7J-	Dimensions with Oil Seal			
	E1	E2	LS1	LS2
02A, 04A, 06A	35	47	5.2	10
08A	47	61	5.5	11

◆ 400 V Models: SGM7J-02, -04

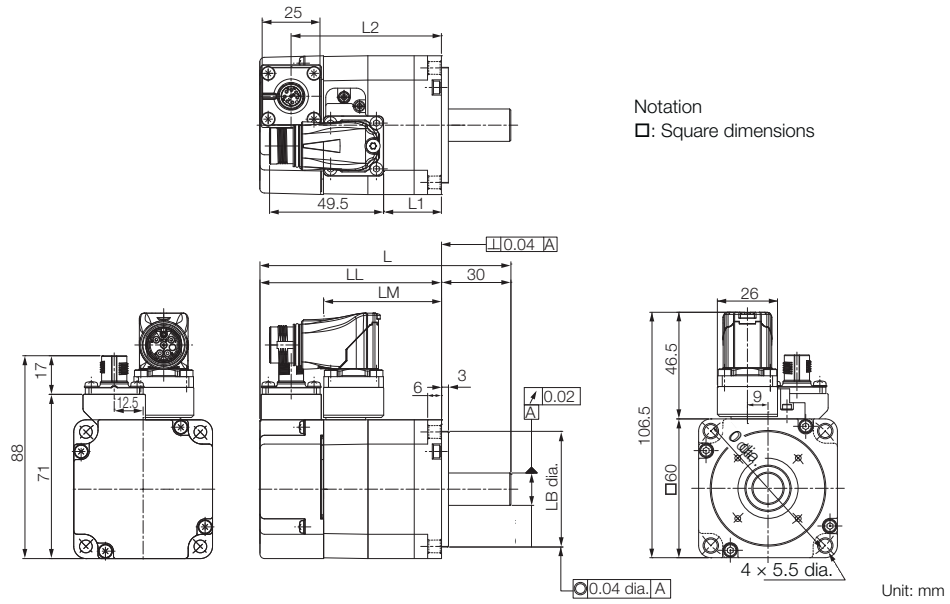

Model SGM7J-	L	LL	LM	LB	S	L1	L2	Approx. Mass [kg]
02D□F2□	108.5 (148.5)	78.5 (118.5)	51.2	50 <sup>0</sup> <sub>-0.025</sub>	14 <sup>0</sup> <sub>-0.011</sub>	25	65 (105)	0.9 (1.5)
04A□F2□	125 (165)	95 (135)	67.2	50 <sup>0</sup> <sub>-0.025</sub>	14 <sup>0</sup> <sub>-0.011</sub>	41.5	81.5 (121.5)	1.2 (1.8)

Note: The values in parentheses are for Servo Motors with Holding Brakes

◆ 400 V Model: SGM7J-08

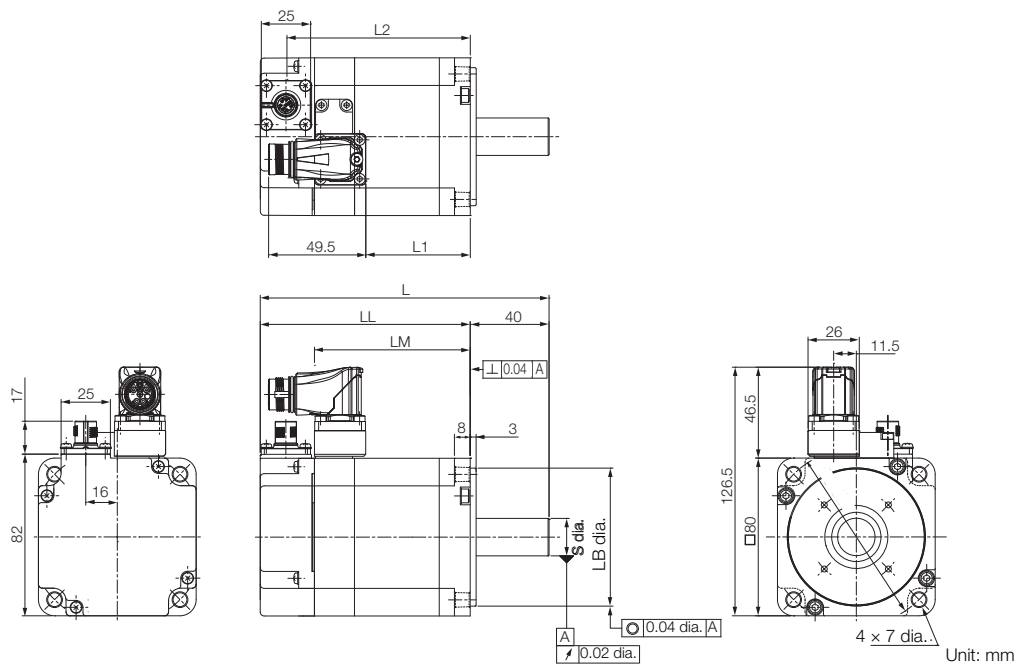

Model SGM7J-	L	LL	LM	LB	S	L1	L2	Approx. Mass [kg]
08D□F2□	146.5 (193.5)	106.5 (153.5)	79	70 <sup>0</sup> <sub>-0.030</sub>	19 <sup>0</sup> <sub>-0.013</sub>	53	93 (121.5)	2.3 (2.9)

Note: The values in parentheses are for Servo Motors with Holding Brakes.



◆ 400 V Models: SGM7J-15

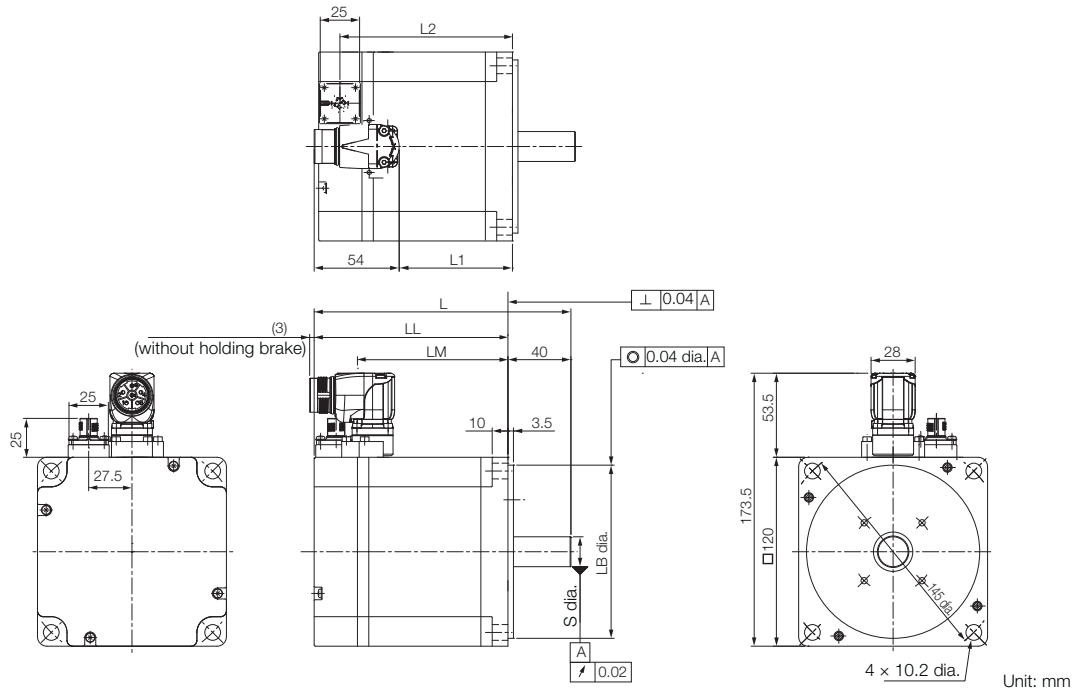

Model SGM7J-	L	LL	LM	LB	S	L1	L2	Approx. Mass [kg]
15D□F2□	163.5 (196.5)	123.5 (156.5)	95.6	110 <sup>0</sup> <sub>-0.035</sub>	19 <sup>0</sup> <sub>-0.013</sub>	72	110 (143)	6.4 (8.1)

Note: The values in parentheses are for Servo Motors with Holding Brakes.

◆ Gear Motor Models: 100W, 200W, 400W (S7J01, S7J02, S7J04)

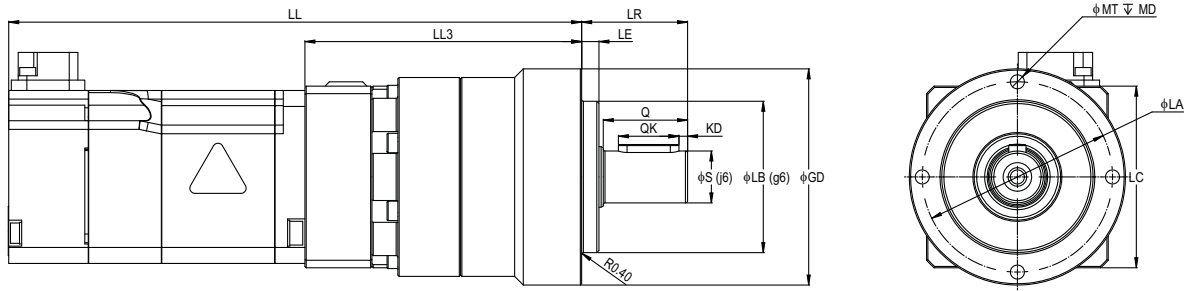

Shaft Detail (VL050 Models Only)

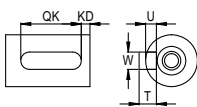

Shaft Detail (All Other Models)

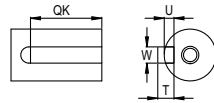

Model S7J	LL	LL3	LR	LE	φS	φLB	φGD	LC	φLA	φMT	MD	Q	QK	KD	W	U	T	
100 W Models																		
200 V	01A□ -VL050-03	133.5 (174)	65	24.5	4	12	35	50	42	44	M4	8	19.5	14	2	4	2.5	4
	01A□ -VL050-05																	
	01A□ -VL050-10																	
	01A□ -VL050-25	150 (190.5)	81.5															
01A□ -VL070-50	163.5 (204)	95	36	5	16	52	70	52	62	M5	10	28	22	0	5	3	5	
200 W Models																		
200 V	02A□ -VL050-03	137.5 (178)	68	24.5	4	12	35	50	65	44	M4	8	19.5	14	2	4	2.5	4
	02A□ -VL050-05																	
	02A□ -VL050-10																	
	02A□ -VL070-25	170.5 (211)	101	36	5	16	52	70	62	M5	10	28	22	0	5	3	5	
400 V	02D□ -VL050-03	146.5 (186.5)	68	24.5	4	12	35	50	65	44	M4	8	19.5	14	2	4	2.5	4
	02D□ -VL050-05																	
	02D□ -VL050-10																	
	02D□ -VL070-25	179.5 (219.5)	101	36	5	16	52	70	62	M5	10	28	22	0	5	3	5	
400 W Models																		
200 V	04A□ -VL050-03	153.5 (194)	68	24.5	4	12	35	50	65	44	M4	8	19.5	14	2	4	2.5	4
	04A□ -VL050-05																	
	04A□ -VL070-10																	
	04A□ -VL070-25	186.5 (227)	101	46	7	22	68	90	80	M6	12	36	28	0	6	3.5	6	
04A□ -VL090-50	204.5 (245)	119	46	7	22	68	90	80	M6	12	36	28	0	6	3.5	6		
400 V	04D□ -VL050-03	163 (203)	68	24.5	4	12	35	50	65	44	M4	8	19.5	14	2	4	2.5	4
	04D□ -VL050-05																	
	04D□ -VL070-10	175 (215)	80	36	5	16	52	70	62	M5	10	28	22	0	5	3	5	
	04D□ -VL070-25	196 (236)	101	46	7	22	68	90	80	M6	12	36	28	0	6	3.5	6	
	04D□ -VL090-50	214 (254)	119	46	7	22	68	90	80	M6	12	36	28	0	6	3.5	6	

Note: The values in parentheses are for Servo Motors with Holding Brakes.

◆ Gear Motor Models: 750W, 1.5kW (S7J08, S7J15)

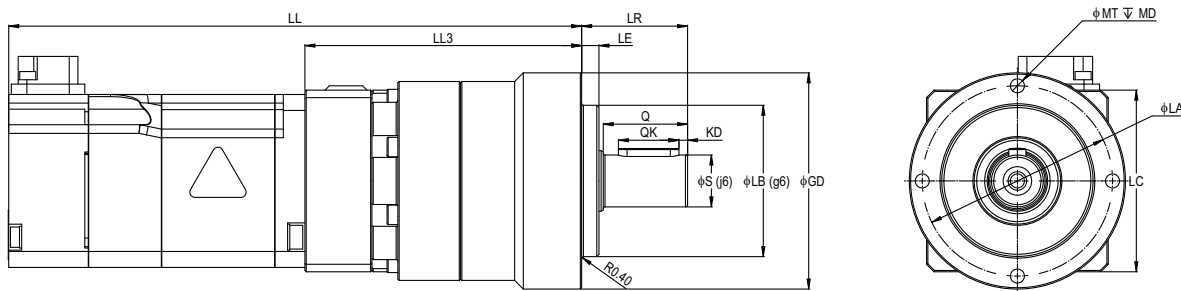

Shaft Detail (VL050 Models Only)

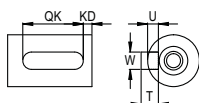

Shaft Detail (All Other Models)

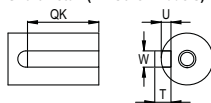

Model S7J	LL	LL3	LR	LE	φS	φLB	φGD	LC	φLA	φMT	MD	Q	QK	KD	W	U	T									
750 W Models																										
200 V	08A□ -VL070-03	191	94	36	5	16	52	70	80	M5	10	28	22	0	5	3	5									
	08A□ -VL070-05	(238)																								
	08A□ -VL090-10	204	107	46	7	22	68	90										80	M6	12	36	28	6	3.5	6	
	08A□ -VL090-25	226	129																							
08A□ -VL090-50	241.5	144.5	70	9	32	90	120	108	M8	16	58	45	10	5	8											
400 V	08D□ -VL070-03	200.5	94	36	5	16	52	70	80	M5	10	28	22	0	5	3	5									
	08D□ -VL070-05	(247.5)																								
	08A□ -VL090-10	213.5	107	46	7	22	68	90										80	M6	12	36	28	6	3.5	6	
	08D□ -VL090-25	235.5	129																							
08D□ -VL090-50	251	144.5	70	9	32	90	120	108	M8	16	58	45	10	5	8											
1.5 kW Models																										
400 V	15D□ -VL090-03	230.5	107	46	7	22	68	90	130	M6	12	36	28	0	6	3.5	6									
	15D□ -VL090-05																	(263.5)								
	15D□ -VL090-10	268	144.5	70	9	32	90	120										108	M8	16	58	45	10	5	8	
	15D□ -VL120-25																	(301)								
15D□ -VL155-50	293	169.5	97	12	40	120	155	140	M10	20	82	65	12													

Note: The values in parentheses are for Servo Motors with Holding Brakes.

# Shaft End Specifications

◆ SGM7J-□□□□□□□□



Code	Specification
2	Straight without key
6	Straight with key and tap for one location (Key slot is JIS B1301-1996 fastening type.)
B	With two flat seats

Shaft End Details	Servo Motor Model SGM7J-						
	A5	01	C2	02	04	06	08
<b>Code: 2 (Straight without Key)</b>							
	LR	25			30		40
	S	$8^{0}_{-0.009}$			$14^{0}_{-0.011}$		$19^{0}_{-0.013}$
<b>Code: 6 (Straight with Key and Tap)</b>							
	LR	25			30		40
	QK	14			14		22
	S	$8^{0}_{-0.009}$			$14^{0}_{-0.011}$		$19^{0}_{-0.013}$
	W	3			5		6
	T	3			5		6
	U	1.8			3		3.5
	P	M3 × 6L			M5 × 8L		M6 × 10L
<b>Code: B (with Two Flat Seats)</b>							
	LR	25			30		40
	QH	15			15		22
	S	$8^{0}_{-0.009}$			$14^{0}_{-0.011}$		$19^{0}_{-0.013}$
	H1	7.5			13		18
	H2	7.5			13		18

## Selecting Cables

### ◆ Cable Configurations

The cables shown below are required to connect a Servo Motor to a SERVOPACK.

Encoder Cable of 20 m or Less

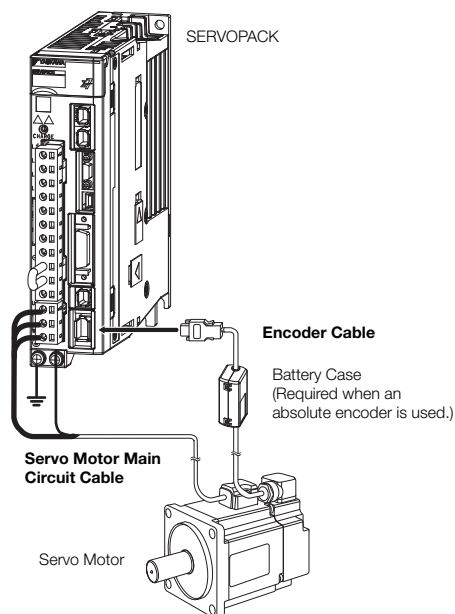

Encoder Cable of 30 m to 50 m (Relay Cable)

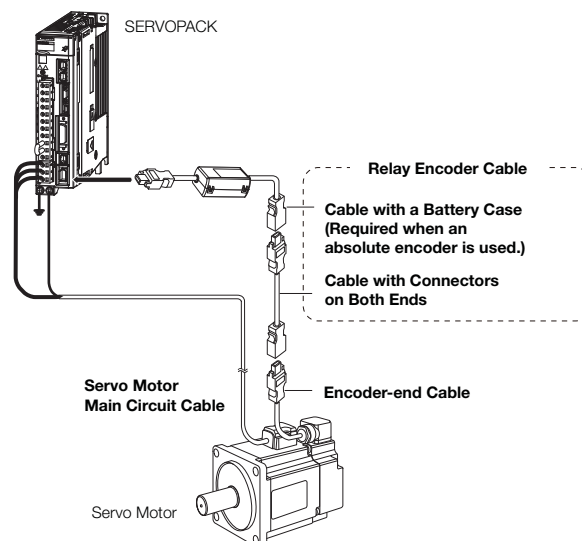

- Note: 1. Cables with connectors on both ends that are compliant with an IP67 protective structure and European Safety  
 2. If the cable length exceeds 20 m, be sure to use a Relay Encoder Cable.  
 3. If you use a Servo Motor Main Circuit Cable that exceeds 20 m, the intermittent duty zone in the torque-motor speed characteristics will become smaller because the voltage drop increases.  
 4. Refer to the following manual for the following information.
- Cable dimensional drawings and cable connection specifications
  - Order numbers and specifications of individual connectors for cables
  - Order numbers and specifications for wiring materials

📖 *Σ-7-Series AC Servo Drive Peripheral Device Selection Manual* (Manual No.: SIEP S800001 32)



Important

For the following Servo Motor models, there are different order numbers for the Servo Motor Main Circuit Cables and Encoder Cables depending on the cable installation direction. Confirm the order numbers before you order.

- All SGM7J models

Cable Installed toward Load

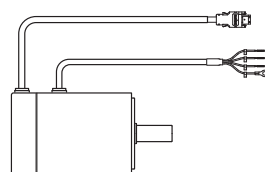

Cable Installed away from Load

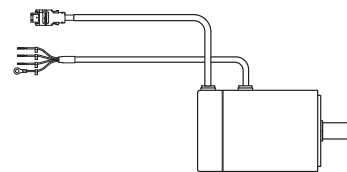

## Servo Motor Main Circuit Cables (200 V Models)

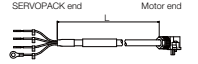
Servo Motor Model	Name	Length (L)	Order Number			Appearance
			Standard Cable	Flexible Cable*	Flexible/Shielded	
SGM7J-A5 to -C2 50 W to 150 W (200V)	Power cable for Servo Motors without Holding Brakes	3 m	JZSP-C7M10F-03-E	JZSP-C7M12F-03-E	YAI-CSM21-03-P-E	
		5 m	JZSP-C7M10F-05-E	JZSP-C7M12F-05-E	YAI-CSM21-05-P-E	
		10 m	JZSP-C7M10F-10-E	JZSP-C7M12F-10-E	YAI-CSM21-10-P-E	
		15 m	JZSP-C7M10F-15-E	JZSP-C7M12F-15-E	YAI-CSM21-15-P-E	
		20 m	JZSP-C7M10F-20-E	JZSP-C7M12F-20-E	YAI-CSM21-20-P-E	
		30 m	JZSP-C7M10F-30-E	JZSP-C7M12F-30-E	YAI-CSM21-30-P-E	
		40 m	JZSP-C7M10F-40-E	JZSP-C7M12F-40-E	YAI-CSM21-40-P-E	
SGM7J-02 to -06 200 W to 600 W (200V)	Cable installed toward load	5 m	JZSP-C7M10F-50-E	JZSP-C7M12F-50-E	YAI-CSM21-50-P-E	
		3 m	JZSP-C7M20F-03-E	JZSP-C7M22F-03-E	YAI-CSM22-03-P-E	
		5 m	JZSP-C7M20F-05-E	JZSP-C7M22F-05-E	YAI-CSM22-05-P-E	
		10 m	JZSP-C7M20F-10-E	JZSP-C7M22F-10-E	YAI-CSM22-10-P-E	
		15 m	JZSP-C7M20F-15-E	JZSP-C7M22F-15-E	YAI-CSM22-15-P-E	
		20 m	JZSP-C7M20F-20-E	JZSP-C7M22F-20-E	YAI-CSM22-20-P-E	
		30 m	JZSP-C7M20F-30-E	JZSP-C7M22F-30-E	YAI-CSM22-30-P-E	
SGM7J-08 750 W (200V)	Cable installed toward load	40 m	JZSP-C7M20F-40-E	JZSP-C7M22F-40-E	YAI-CSM22-40-P-E	
		50 m	JZSP-C7M20F-50-E	JZSP-C7M22F-50-E	YAI-CSM22-50-P-E	
		3 m	JZSP-C7M30F-03-E	JZSP-C7M32F-03-E	YAI-CSM23-03-P-E	
		5 m	JZSP-C7M30F-05-E	JZSP-C7M32F-05-E	YAI-CSM23-05-P-E	
		10 m	JZSP-C7M30F-10-E	JZSP-C7M32F-10-E	YAI-CSM23-10-P-E	
		15 m	JZSP-C7M30F-15-E	JZSP-C7M32F-15-E	YAI-CSM23-15-P-E	
		20 m	JZSP-C7M30F-20-E	JZSP-C7M32F-20-E	YAI-CSM23-20-P-E	
SGM7J-A5 to -C2 50 W to 150 W (200V)	Power cable for Servo Motors without Holding Brakes	30 m	JZSP-C7M30F-30-E	JZSP-C7M32F-30-E	YAI-CSM23-30-P-E	<p style="text-align: center;">N/A</p> 
		40 m	JZSP-C7M30F-40-E	JZSP-C7M32F-40-E	YAI-CSM23-40-P-E	
		50 m	JZSP-C7M30F-50-E	JZSP-C7M32F-50-E	YAI-CSM23-50-P-E	
		3 m	JZSP-C7M10G-03-E	JZSP-C7M12G-03-E		
		5 m	JZSP-C7M10G-05-E	JZSP-C7M12G-05-E		
		10 m	JZSP-C7M10G-10-E	JZSP-C7M12G-10-E		
		15 m	JZSP-C7M10G-15-E	JZSP-C7M12G-15-E		
SGM7J-02 to -06 200 W to 600 W (200V)	Cable installed away from load	20 m	JZSP-C7M10G-20-E	JZSP-C7M12G-20-E		
		30 m	JZSP-C7M10G-30-E	JZSP-C7M12G-30-E		
		40 m	JZSP-C7M10G-40-E	JZSP-C7M12G-40-E		
		50 m	JZSP-C7M10G-50-E	JZSP-C7M12G-50-E		
		3 m	JZSP-C7M20G-03-E	JZSP-C7M22G-03-E		
		5 m	JZSP-C7M20G-05-E	JZSP-C7M22G-05-E		
		10 m	JZSP-C7M20G-10-E	JZSP-C7M22G-10-E		
SGM7J-08 750 W (200V)	Cable installed away from load	15 m	JZSP-C7M20G-15-E	JZSP-C7M22G-15-E		
		20 m	JZSP-C7M20G-20-E	JZSP-C7M22G-20-E		
		30 m	JZSP-C7M20G-30-E	JZSP-C7M22G-30-E		
		40 m	JZSP-C7M20G-40-E	JZSP-C7M22G-40-E		
		50 m	JZSP-C7M20G-50-E	JZSP-C7M22G-50-E		
		3 m	JZSP-C7M30G-03-E	JZSP-C7M32G-03-E		
		5 m	JZSP-C7M30G-05-E	JZSP-C7M32G-05-E		
10 m	JZSP-C7M30G-10-E	JZSP-C7M32G-10-E				
15 m	JZSP-C7M30G-15-E	JZSP-C7M32G-15-E				
20 m	JZSP-C7M30G-20-E	JZSP-C7M32G-20-E				
30 m	JZSP-C7M30G-30-E	JZSP-C7M32G-30-E				
40 m	JZSP-C7M30G-40-E	JZSP-C7M32G-40-E				
50 m	JZSP-C7M30G-50-E	JZSP-C7M32G-50-E				

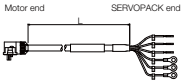
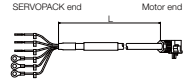
Servo Motor Model	Name	Length (L)	Order Number			Appearance		
			Standard Cable	Flexible Cable*	Flexible/Shielded			
SGM7J-A5 to -C2 50 W to 150 W (200V)	Power cable for Servo Motors with Holding Brakes	3 m	JZSP-C7M13F-03-E	JZSP-C7M14F-03-E	YAI-CSM31-03-P-E			
		5 m	JZSP-C7M13F-05-E	JZSP-C7M14F-05-E	YAI-CSM31-05-P-E			
		10 m	JZSP-C7M13F-10-E	JZSP-C7M14F-10-E	YAI-CSM31-10-P-E			
		15 m	JZSP-C7M13F-15-E	JZSP-C7M14F-15-E	YAI-CSM31-15-P-E			
		20 m	JZSP-C7M13F-20-E	JZSP-C7M14F-20-E	YAI-CSM31-20-P-E			
		30 m	JZSP-C7M13F-30-E	JZSP-C7M14F-30-E	YAI-CSM31-30-P-E			
		40 m	JZSP-C7M13F-40-E	JZSP-C7M14F-40-E	YAI-CSM31-40-P-E			
SGM7J-02 to -06 200 W to 600 W (200V)	Cable installed toward load	50 m	JZSP-C7M13F-50-E	JZSP-C7M14F-50-E	YAI-CSM31-50-P-E			
		3 m	JZSP-C7M23F-03-E	JZSP-C7M24F-03-E	YAI-CSM32-03-P-E			
		5 m	JZSP-C7M23F-05-E	JZSP-C7M24F-05-E	YAI-CSM32-05-P-E			
		10 m	JZSP-C7M23F-10-E	JZSP-C7M24F-10-E	YAI-CSM32-10-P-E			
		15 m	JZSP-C7M23F-15-E	JZSP-C7M24F-15-E	YAI-CSM32-15-P-E			
		20 m	JZSP-C7M23F-20-E	JZSP-C7M24F-20-E	YAI-CSM32-20-P-E			
		30 m	JZSP-C7M23F-30-E	JZSP-C7M24F-30-E	YAI-CSM32-30-P-E			
SGM7J-08 750 W (200V)	Cable installed toward load	40 m	JZSP-C7M23F-40-E	JZSP-C7M24F-40-E	YAI-CSM32-40-P-E			
		50 m	JZSP-C7M23F-50-E	JZSP-C7M24F-50-E	YAI-CSM32-50-P-E			
		3 m	JZSP-C7M33F-03-E	JZSP-C7M34F-03-E	YAI-CSM33-03-P-E			
		5 m	JZSP-C7M33F-05-E	JZSP-C7M34F-05-E	YAI-CSM33-05-P-E			
		10 m	JZSP-C7M33F-10-E	JZSP-C7M34F-10-E	YAI-CSM33-10-P-E			
		15 m	JZSP-C7M33F-15-E	JZSP-C7M34F-15-E	YAI-CSM33-15-P-E			
		20 m	JZSP-C7M33F-20-E	JZSP-C7M34F-20-E	YAI-CSM33-20-P-E			
SGM7J-A5 to -C2 50 W to 150 W (200V)	Power cable for Servo Motors with Holding Brakes	30 m	JZSP-C7M33F-30-E	JZSP-C7M34F-30-E	YAI-CSM33-30-P-E			
		40 m	JZSP-C7M33F-40-E	JZSP-C7M34F-40-E	YAI-CSM33-40-P-E			
		50 m	JZSP-C7M33F-50-E	JZSP-C7M34F-50-E	YAI-CSM33-50-P-E			
		SGM7J-02 to -06 200 W to 600 W (200V)	Cable installed away from load	3 m	JZSP-C7M13G-03-E		JZSP-C7M14G-03-E	N/A
				5 m	JZSP-C7M13G-05-E		JZSP-C7M14G-05-E	
				10 m	JZSP-C7M13G-10-E		JZSP-C7M14G-10-E	
				15 m	JZSP-C7M13G-15-E		JZSP-C7M14G-15-E	
20 m	JZSP-C7M13G-20-E			JZSP-C7M14G-20-E				
30 m	JZSP-C7M13G-30-E			JZSP-C7M14G-30-E				
40 m	JZSP-C7M13G-40-E			JZSP-C7M14G-40-E				
SGM7J-08 750 W (200V)	Cable installed away from load	50 m	JZSP-C7M13G-50-E	JZSP-C7M14G-50-E				
		3 m	JZSP-C7M23G-03-E	JZSP-C7M24G-03-E				
		5 m	JZSP-C7M23G-05-E	JZSP-C7M24G-05-E				
		10 m	JZSP-C7M23G-10-E	JZSP-C7M24G-10-E				
		15 m	JZSP-C7M23G-15-E	JZSP-C7M24G-15-E				
		20 m	JZSP-C7M23G-20-E	JZSP-C7M24G-20-E				
		30 m	JZSP-C7M23G-30-E	JZSP-C7M24G-30-E				
SGM7J-08 750 W (200V)	Cable installed away from load	40 m	JZSP-C7M23G-40-E	JZSP-C7M24G-40-E				
		50 m	JZSP-C7M23G-50-E	JZSP-C7M24G-50-E				
		3 m	JZSP-C7M33G-03-E	JZSP-C7M34G-03-E				
		5 m	JZSP-C7M33G-05-E	JZSP-C7M34G-05-E				
		10 m	JZSP-C7M33G-10-E	JZSP-C7M34G-10-E				
		15 m	JZSP-C7M33G-15-E	JZSP-C7M34G-15-E				
		20 m	JZSP-C7M33G-20-E	JZSP-C7M34G-20-E				
SGM7J-08 750 W (200V)	Cable installed away from load	30 m	JZSP-C7M33G-30-E	JZSP-C7M34G-30-E				
		40 m	JZSP-C7M33G-40-E	JZSP-C7M34G-40-E				
		50 m	JZSP-C7M33G-50-E	JZSP-C7M34G-50-E				

\* Use Flexible Cables for moving parts of machines, such as robots.

## Servo Motor Main Circuit Cables (400 V Models)

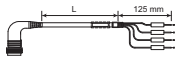
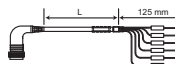
Servo Motor Model	Name	Length (L)	Order Number			Appearance
			Standard Cable	Flexible Cable*	Flexible/Shielded	
SGM7J-02 to -08 200W to 750 W (400V)	Power Cable with-out Brake. Cable installed toward load	3 m	N/A	N/A	JZSP-C7M143-03-E-G6	
		5 m	N/A	N/A	JZSP-C7M143-05-E-G6	
		10 m	N/A	N/A	JZSP-C7M143-10-E-G6	
		15 m	N/A	N/A	JZSP-C7M143-15-E-G6	
		20 m	N/A	N/A	JZSP-C7M143-20-E-G6	
SGM7J-15 1.5 kW (400V)		3 m	N/A	N/A	JZSP-C7M144-03-E-G6	
		5 m	N/A	N/A	JZSP-C7M144-05-E-G6	
		10 m	N/A	N/A	JZSP-C7M144-10-E-G6	
		15 m	N/A	N/A	JZSP-C7M144-15-E-G6	
		20 m	N/A	N/A	JZSP-C7M144-20-E-G6	
SGM7J-02 to -08 200W to 750 W (400V)	Power Cable with Brake. Cable installed toward load	3 m	N/A	N/A	JZSP-C7M343-03-E-G6	
		5 m	N/A	N/A	JZSP-C7M343-05-E-G6	
		10 m	N/A	N/A	JZSP-C7M343-10-E-G6	
		15 m	N/A	N/A	JZSP-C7M343-15-E-G6	
		20 m	N/A	N/A	JZSP-C7M343-20-E-G6	
SGM7J-15 1.5 kW (400V)		3 m	N/A	N/A	JZSP-C7M344-03-E-G6	
		5 m	N/A	N/A	JZSP-C7M344-05-E-G6	
		10 m	N/A	N/A	JZSP-C7M344-10-E-G6	
		15 m	N/A	N/A	JZSP-C7M344-15-E-G6	
		20 m	N/A	N/A	JZSP-C7M344-20-E-G6	

\* Use Flexible Cables for moving parts of machines, such as robots.



## Encoder Cables of 20 m or Less (200V Models)

Servo Motor Model	Name	Length (L)	Order Number		Appearance
			Standard Cable	Flexible Cable* <sup>1</sup>	
SGM7J-A5 to -08 50 W to 750 W	For incremental encoder  Cable installed toward load	3 m	JZSP-C7PI0D-03-E	JZSP-C7PI2D-03-E	
		5 m	JZSP-C7PI0D-05-E	JZSP-C7PI2D-05-E	
		10 m	JZSP-C7PI0D-10-E	JZSP-C7PI2D-10-E	
		15 m	JZSP-C7PI0D-15-E	JZSP-C7PI2D-15-E	
		20 m	JZSP-C7PI0D-20-E	JZSP-C7PI2D-20-E	
	For incremental encoder  Cable installed away from load	3 m	JZSP-C7PI0E-03-E	JZSP-C7PI2E-03-E	
		5 m	JZSP-C7PI0E-05-E	JZSP-C7PI2E-05-E	
		10 m	JZSP-C7PI0E-10-E	JZSP-C7PI2E-10-E	
		15 m	JZSP-C7PI0E-15-E	JZSP-C7PI2E-15-E	
		20 m	JZSP-C7PI0E-20-E	JZSP-C7PI2E-20-E	
	For absolute encoder: With Battery Case* <sup>2</sup>  Cable installed toward load	3 m	JZSP-C7PA0D-03-E	JZSP-C7PA2D-03-E	
		5 m	JZSP-C7PA0D-05-E	JZSP-C7PA2D-05-E	
		10 m	JZSP-C7PA0D-10-E	JZSP-C7PA2D-10-E	
		15 m	JZSP-C7PA0D-15-E	JZSP-C7PA2D-15-E	
		20 m	JZSP-C7PA0D-20-E	JZSP-C7PA2D-20-E	
	For absolute encoder: With Battery Case* <sup>2</sup>  Cable installed away from load	3 m	JZSP-C7PA0E-03-E	JZSP-C7PA2E-03-E	
		5 m	JZSP-C7PA0E-05-E	JZSP-C7PA2E-05-E	
		10 m	JZSP-C7PA0E-10-E	JZSP-C7PA2E-10-E	
		15 m	JZSP-C7PA0E-15-E	JZSP-C7PA2E-15-E	
		20 m	JZSP-C7PA0E-20-E	JZSP-C7PA2E-20-E	

\*1. Use Flexible Cables for moving parts of machines, such as robots.

\*2. If a battery is connected to host controller, the Battery Case is not required. If so, use a cable for incremental encoders.

## Encoder Cables of 20 m or Less (400V Models)

Servo Motor Model	Name	Length (L)	Order Number		Appearance
			Standard Cable	Flexible Cable* <sup>1</sup>	
SGM7J-02 to -15 200 W to 1.5 kW	For incremental encoder  Cable installed toward load	3 m	N/A	JZSP-C7PI2N-03-E-G6	
		5 m	N/A	JZSP-C7PI2N-03-E-G6	
		10 m	N/A	JZSP-C7PI2N-03-E-G6	
		15 m	N/A	JZSP-C7PI2N-03-E-G6	
		20 m	N/A	JZSP-C7PI2N-03-E-G6	

## Relay Encoder Cable of 30 m to 50 m

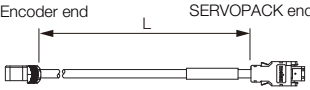
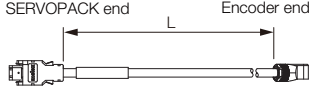
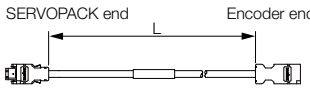
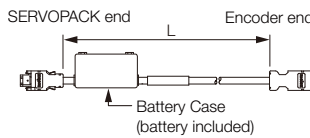
Servo Motor Model	Name	Length (L)	Order Number	Appearance
SGM7J-A5 to -08 50 W to 750 W	Encoder-end Cable (for incremental or absolute encoder) Cable installed toward load	0.3 m	JZSP-C7PRCD-E	
	Encoder-end Cable (for incremental or absolute encoder) Cable installed away from load	0.3 m	JZSP-C7PRCE-E	
	Cables with Connectors on Both Ends (for incremental or absolute encoder)	30 m	JZSP-UCMP00-30-E	
		40 m	JZSP-UCMP00-40-E	
		50 m	JZSP-UCMP00-50-E	
Cable with a Battery Case (Required when an absolute encoder is used.*)	0.3 m	JZSP-CSP12-E		

\* This Cable is not required if a battery is connected to the host controller.



# SGM7A

## SGM7A Servo Motors (without Gear Box)

### Model Designations

SGM7A - 01 A 7 D 6 1

Σ-7 Series Servo Motors: SGM7A
1st+2nd digits
3rd digit
4th digit
5th digit
6th digit
7th digit

**1st+2nd digits** Rated Output

Code	Specification
A5	50 W
01	100 W
C2	150 W
02	200 W
04	400 W
06	600 W
08	750 W
10	1.0 kW
15	1.5 kW
20	2.0 kW
25	2.5 kW
30	3.0 kW
40	4.0 kW
50	5.0 kW
70	7.0 kW

**3rd digit** Power Supply Voltage

Code	Specification
A	200 VAC
D	400 VAC

**4th digit** Serial Encoder

Code	Specification
7	24-bit absolute
F	24-bit incremental

**5th digit** Design Revision Order

D: Global design revision (200 V)  
F: Global design revision (400 V)

■ Non Stock Items

**6th digit** Shaft End

Code	Specification
2	Straight without key
6	Straight with key and tap
B*	With two flat seats

\* Code B is not supported for models with a rated output of 1.5 kW or higher.

**7th digit** Options

Code	Specification
1	Without options
C	With holding brake (24 VDC)
E	With oil seal and holding brake (24 VDC)
S	With oil seal

Note: SGM7A-70A Servo Motors with holding brakes are not available.

# SGM7A

## SGM7A Gear Motors

The SGM7A gear motor product family pairs SGM7A servo motors with high precision, low backlash inline planetary gear heads resulting in a portfolio of rotary actuators fit for a wide range of applications. The family of gear motors has been thoroughly tested and adheres to the high levels of quality and performance expected from Yaskawa.

The high precision gear heads offer a variety of application advantages:

- ① **Quiet operation** – helical cut gears contribute toward reduced vibration and noise
- ② **High precision** – a standard backlash of 5 arc-min make this gear head ideal for the most accurate applications
- ③ **High rigidity and torque capacity** – achieved with a design which incorporates uncaged needle roller bearings
- ④ **Optimized adapter bushing** – minimizes inertia allowing for more output torque to be realized
- ⑤ **No leakage through the seal** – high viscosity, anti-separation grease does not liquefy and does not migrate away from the gears
- **Maintenance-free** – no need to replace the grease for the life of the unit. The reducer can be positioned in any orientation

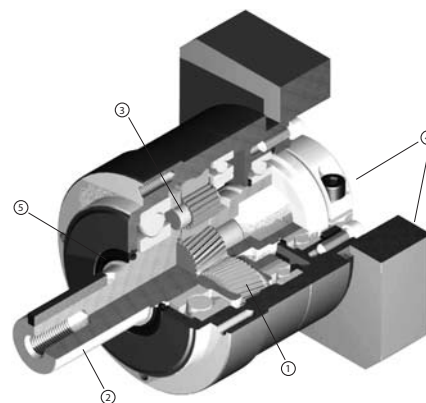

## Model Designations

S7A 01 A C - VL 050 - 05

Σ-7 Series  
Gear Motors:  
SGM7A

1st+2nd  
digits

3rd  
digit

4th  
digit

5th  
digit

6th  
digit

7th  
digit

1st+2nd digits Rated Output

Code	Specification
01	100 W
02	200 W
04	400 W
08	750 W
10	1.0 kW
15	1.5 kW
20	2.0 kW
25	2.5 kW
30	3.0 kW
40	4.0 kW
50	5.0 kW
70	7.0 kW

3rd digit Power Supply Voltage

Code	Specification
A	200 VAC
D	400 VAC

4th digit Brake Option

Code	Specification
Blank	No brake
C	24 V Brake

5th digit Gear box backlash

Code	Specification
VL	5 arc-min backlash

6th digit Gear head frame size

Code	Specification
050	50 mm
070	70 mm
090	90 mm
120	120 mm
155	155 mm
205	205mm
235	235mm

7th digit Gear Ratio

Code	Specification
03	3:1 Ratio
05	5:1 Ratio
10	10:1 Ratio
25	25:1 Ratio
50	50:1 Ratio

## Specifications and Ratings

### Specifications (200 V Models)

Voltage		200 V	
Model SGM7A-		A5A to 70A	
Time Rating		Continuous	
Thermal Class		A5A to 10A	UL: B, CE: B
		15A to 70A	UL: F, CE: F
Insulation Resistance		500 VDC, 10 MΩmin.	
Withstand Voltage		1,500 VAC for 1 minute	
Excitation		Permanent magnet	
Mounting		Flange-mounted	
Drive Method		Direct drive	
Rotation Direction		Counterclockwise (CCW) for forward reference when viewed from the load side	
Vibration Class <sup>*1</sup>		V15	
Environmental Conditions	Surrounding Air Temperature	0°C to 40°C (With derating, usage is possible between 40°C and 60°C.) <sup>*4</sup>	
	Surrounding Air Humidity	20% to 80% relative humidity (with no condensation)	
	Installation Site	<ul style="list-style-type: none"> <li>• Must be indoors and free of corrosive and explosive gases.</li> <li>• Must be well-ventilated and free of dust and moisture.</li> <li>• Must facilitate inspection and cleaning.</li> <li>• Must have an altitude of 1,000 m or less. (With derating, usage is possible between 1,000 m and 2,000 m.)<sup>*5</sup></li> <li>• Must be free of strong magnetic fields.</li> </ul>	
	Storage Environment	Store the Servo Motor in the following environment if you store it with the power cable disconnected. Storage Temperature: -20°C to 60°C (with no freezing) Storage Humidity: 20% to 80% relative humidity (with no condensation)	
Shock Resistance <sup>*2</sup>	Impact Acceleration Rate at Flange	490 m/s <sup>2</sup>	
	Number of Impacts	2 times	
Vibration Resistance <sup>*3</sup>	Vibration Acceleration Rate at Flange	A5A to 50A	49 m/s <sup>2</sup> (Models 15A to 50A: 24.5 m/s <sup>2</sup> front to back)
		70A	14.7 m/s
Applicable SERVOPACKS		Refer to the following section.  <b>Σ-7 Series Combination (page M-8)</b>	

\*1. A vibration class of V15 indicates a vibration amplitude of 15 μm maximum on the Servo Motor without a load at the rated motor speed.

\*2. The shock resistance for shock in the vertical direction when the Servo Motor is mounted with the shaft in a horizontal position is given in the above table.

\*3. The vertical, side-to-side, and front-to-back vibration resistance for vibration in three directions when the Servo Motor is mounted with the shaft in a horizontal position is given in the above table. The strength of the vibration that the Servo Motor can withstand depends on the application. Always check the vibration acceleration rate that is applied to the Servo Motor with the actual equipment.

\*4. If the surrounding air temperature will exceed 40°C, refer to the following section.

 **Applications Where the Surrounding Air Temperature of the Servo Motor Exceeds 40°C (page 63)**

\*5. If the altitude will exceed 1,000 m, refer to the following section.

 **Applications Where the Altitude of the Servo Motor Exceeds 1,000 m (page 64)**

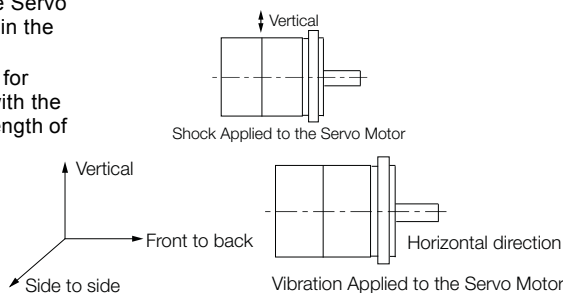

## Ratings of Servo Motors (200 V Models -A5A to -10A)

Voltage		200 V								
Model SGM7A-		A5A	01A	C2A	02A	04A	06A	08A	10A	
Rated Output <sup>*1</sup>	W	50	100	150	200	400	600	750	1000	
Rated Torque <sup>*1, *2</sup>	N•m	0.159	0.318	0.477	0.637	1.27	1.91	2.39	3.18	
Instantaneous Maximum Torque <sup>*1</sup>	N•m	0.557	1.11	1.67	2.23	4.46	6.69	8.36	11.1	
Rated Current <sup>*1</sup>	Arms	0.57	0.89	1.5	1.5	2.4	4.5	4.4	6.4	
Instantaneous Maximum Current <sup>*1</sup>	Arms	2.1	3.2	5.6	5.9	9.3	16.9	16.8	23.2	
Rated Motor Speed <sup>*1</sup>	min <sup>-1</sup>	3000								
Maximum Motor Speed <sup>*1</sup>	min <sup>-1</sup>	6000								
Torque Constant	N•m/Arms	0.304	0.384	0.332	0.458	0.576	0.456	0.584	0.541	
Motor Moment of Inertia	$\times 10^{-4}$ kg•m <sup>2</sup>	0.0217 (0.0297)	0.0337 (0.0417)	0.0458 (0.0538)	0.139 (0.209)	0.216 (0.286)	0.315 (0.385)	0.775 (0.955)	0.971 (1.15)	
Rated Power Rate <sup>*1</sup>	kW/s	11.7 (8.51)	30.0 (24.2)	49.7 (42.2)	29.2 (19.4)	74.7 (56.3)	115 (94.7)	73.7 (59.8)	104 (87.9)	
Rated Angular Acceleration Rate <sup>*1</sup>	rad/s <sup>2</sup>	73200 (53500)	94300 (76200)	104000 (88600)	45800 (30400)	58700 (44400)	60600 (49600)	30800 (25000)	32700 (27600)	
Derating Rate for Servo Motor with Oil Seal	%	80	90			95				
Heat Sink Size (Aluminum)	mm	200 × 200 × 6		250 × 250 × 6			300 × 300 × 12 <sup>*7</sup>	250 × 250 × 6	300 × 300 × 12	
Protective Structure <sup>*3</sup>	Totally enclosed, self-cooled, IP67									
Holding Brake Specifications <sup>*4</sup>	Rated Voltage	V	24 VDC±10%							
	Capacity	W	5.5			6		6.5		
	Holding Torque	N•m	0.159	0.318	0.477	0.637	1.27	1.91	2.39	3.18
	Coil Resistance	Ω(at 20°C)	104.8±10%			96±10%		88.6±10%		
	Rated Current	A (at 20°C)	0.23			0.25		0.27		
	Time Required to Release Brake	ms	60					80		
	Time Required to Brake	ms	100							
Allowable Load Moment of Inertia (Motor Moment of Inertia Ratio)			40 times		30 times	20 times		20 times		
Allowable Shaft Loads <sup>*5</sup>	LF	mm	20		25		35			
	Allowable Radial Load	N	78		245		392			
	Allowable Thrust Load	N	54		74		147			

Note: 1. The values in parentheses are for Servo Motors with Holding Brakes.

2. Refer to the following section for footnotes \*1 to \*5 and \*7.

 **Notes for Ratings of Servo Motor (page 54)**

## Torque-Motor Speed Characteristics (200 V Models -A5A to -10A)

A : Continuous duty zone      — (solid lines): With three-phase 200-V or single-phase 230-V input  
B : Intermittent duty zone      - - - - (dotted lines): With single-phase 200-V input

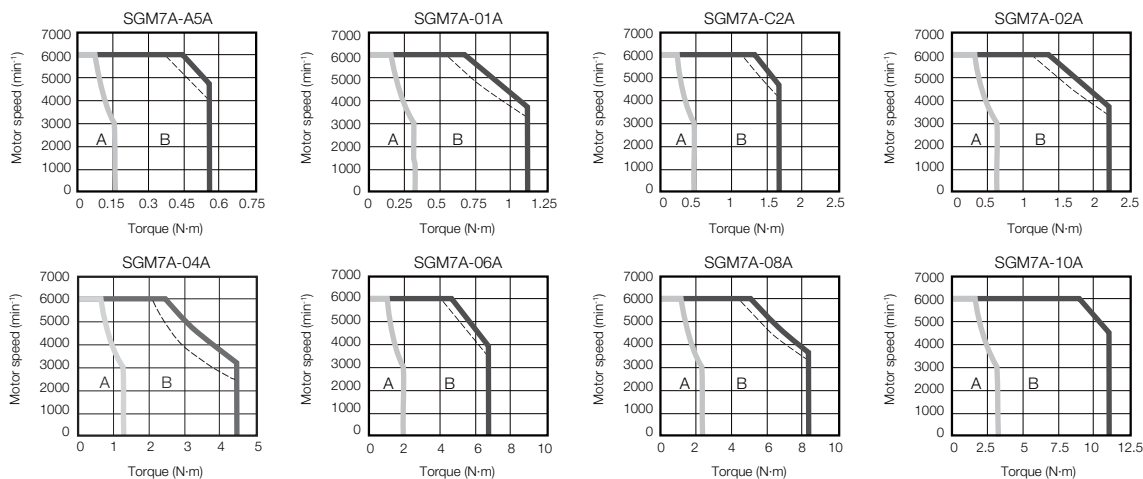

Note: 1. These values are for operation in combination with a SERVOPACK when the temperature of the armature winding is 100°C. These are typical values.

2. The characteristics in the intermittent duty zone depend on the power supply voltage.
3. If the effective torque is within the allowable range for the rated torque, the Servo Motor can be used within the intermittent duty zone.
4. If you use a Servo Motor Main Circuit Cable that exceeds 20 m, the intermittent duty zone in the torque-motor speed characteristics will become smaller because the voltage drop increases.



## Servo Motor Ratings (200 V Models -15A to -70A)

Voltage		200 V						
Model SGM7A-		15A	20A	25A	30A	40A	50A	70A
Rated Output <sup>*6</sup>	kW	1.5	2.0	2.5	3.0	4.0	5.0	7.0
Rated Torque <sup>*2, *6</sup>	N•m	4.90	6.36	7.96	9.80	12.6	15.8	22.3
Instantaneous Maximum Torque <sup>*6</sup>	N•m	14.7	19.1	23.9	29.4	37.8	47.6	54.0
Rated Current <sup>*6</sup>	Arms	9.3	12.1	15.6	17.9	25.4	27.6	38.3
Instantaneous Maximum Current <sup>*6</sup>	Arms	28	42	51	56	77	84	105
Rated Motor Speed <sup>*6</sup>	min <sup>-1</sup>	3000						
Maximum Motor Speed <sup>*6</sup>	min <sup>-1</sup>	6000 <sup>*8</sup>						
Torque Constant	N•m/Arms	0.590	0.561	0.538	0.582	0.519	0.604	0.604
Motor Moment of Inertia	×10 <sup>-4</sup> kg•m <sup>2</sup>	2.00 (2.25)	2.47 (2.72)	3.19 (3.44)	7.00 (9.20)	9.60 (11.8)	12.3 (14.5)	12.3
Rated Power Rate <sup>*6</sup>	kW/s	120 (106)	164 (148)	199 (184)	137 (104)	165 (134)	203 (172)	404
Rated Angular Acceleration Rate <sup>*6</sup>	rad/s <sup>2</sup>	24500 (21700)	25700 (23300)	24900 (23100)	14000 (10600)	13100 (10600)	12800 (10800)	18100
Heat Sink Size (Aluminum)	mm	300 × 300 × 12			400 × 400 × 20			
Protective Structure <sup>*3</sup>		Totally enclosed, self-cooled, IP67						Totally enclosed, separately cooled (with fan), IP22
Holding Brake Specifications <sup>*4</sup>	Rated Voltage	V	24 VDC <sup>+10%</sup> <sub>0</sub>					
	Capacity	W	12			10		
	Holding Torque	N•m	7.84		10		20	
	Coil Resistance	Ω (at 20°C)	48			59		
	Rated Current	A (at 20°C)	0.5			0.41		
	Time Required to Release Brake	ms	170			100		
	Time Required to Brake	ms	80					
Allowable Load Moment of Inertia (Motor Moment of Inertia Ratio)		10 times			5 times			
Allowable Shaft Loads <sup>*5</sup>	LF	mm	45			63		
	Allowable Radial Load	N	686		980		1176	
	Allowable Thrust Load	N	196			392		

Note: 1. The values in parentheses are for Servo Motors with Holding Brakes.

2. Refer to the following section for footnotes \*2 to \*6.

 **Notes for Ratings of Servo Motor (page 54)**

## Torque-Motor Speed Characteristics (200 V Models -15A to -70A)

**A** : Continuous duty zone

**B** : Intermittent duty zone

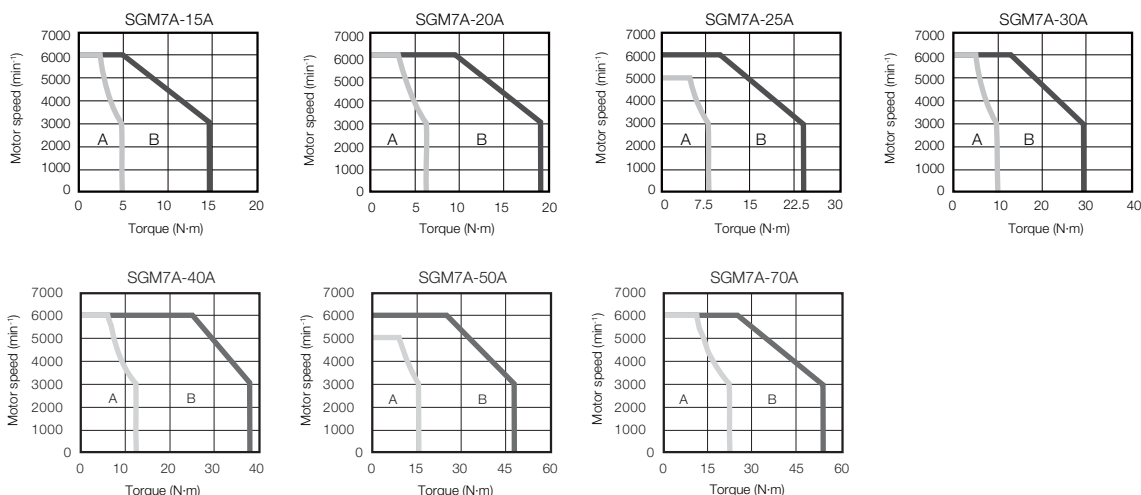

Note: 1. These values are for operation in combination with a SERVOPACK when the temperature of the armature winding is 20°C. These are typical values.

2. The characteristics in the intermittent duty zone depend on the power supply voltage.
3. If the effective torque is within the allowable range for the rated torque, the Servo Motor can be used within the intermittent duty zone.
4. If you use a Servo Motor Main Circuit Cable that exceeds 20 m, the intermittent duty zone in the torque-motor speed characteristics will become smaller because the voltage drop increases.

### ■ Notes for Ratings of Servo Motor

- \*1. These values are for operation in combination with a SERVOPACK when the temperature of the armature winding is 100°C. The values for other items are at 20°C. These are typical values.
- \*2. The rated torques are the continuous allowable torque values at a surrounding air temperature of 40°C with an aluminum heat sink of the dimensions given in the table.
- \*3. This does not apply to the shaft opening. Protective structure specifications apply only when the special cable is used.
- \*4. Observe the following precautions if you use a Servo Motor with a Holding Brake.
  - The holding brake cannot be used to stop the Servo Motor.
  - The time required to release the brake and the time required to brake depend on which discharge circuit is used. Confirm that the operation delay time is appropriate for the actual equipment.
  - The 24-VDC power supply is not provided by Yaskawa.
- \*5. The allowable shaft loads are illustrated in the following figure. Design the mechanical system so that the thrust and radial loads applied to the Servo Motor shaft end during operation do not exceed the values given in the table.

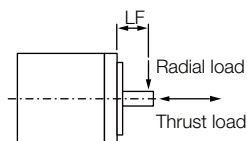

- \*6. These values are for operation in combination with a SERVOPACK when the temperature of the armature winding is 20°C. These are typical values.
- \*7. If the heat sink is 250 mm × 250 mm × 6 mm, the rated output is 550 W and the rated torque is 1.75 N·m. Refer to the following section for details.

#### Servo Motor Heat Dissipation Conditions (page 62)

- \*8. For the SGM7A-25A or SGM7A-50A, the maximum motor speed for the continuous duty zone is 5,000 min<sup>-1</sup>. Use the Servo Motor within the continuous duty zone for the average motor speed and effective torque.

## Specifications (400 V Models)

Voltage		400 V			
Model SGM7A-		02D	04D	08D	10D
Time Rating		Continuous			
Thermal Class		B			
Insulation Resistance		500 VDC, 10 MΩmin.			
Withstand Voltage		1,800 VAC for 1 minute			
Excitation		Permanent magnet			
Mounting		Flange-mounted			
Drive Method		Direct drive			
Rotation Direction		Counterclockwise (CCW) for forward reference when viewed from the load side			
Vibration Class <sup>*1</sup>		V15			
Environmental Conditions	Surrounding Air Temperature	0°C to 40°C (With derating, usage is possible between 40°C and 60°C.) <sup>*4</sup>			
	Surrounding Air Humidity	20% to 80% relative humidity (with no condensation)			
	Installation Site	<ul style="list-style-type: none"> <li>• Must be indoors and free of corrosive and explosive gases.</li> <li>• Must be well-ventilated and free of dust and moisture.</li> <li>• Must facilitate inspection and cleaning.</li> <li>• Must have an altitude of 1,000 m or less. (With derating, usage is possible between 1,000 m and 2,000 m.)<sup>*5</sup></li> <li>• Must be free of strong magnetic fields.</li> </ul>			
	Storage Environment	Store the Servo Motor in the following environment if you store it with the power cable disconnected. Storage Temperature: -20°C to 60°C (with no freezing) Storage Humidity: 20% to 80% relative humidity (with no condensation)			
Shock Resistance <sup>*2</sup>	Impact Acceleration Rate at Flange	490 m/s <sup>2</sup>			
	Number of Impacts	2 times			
Vibration Resistance <sup>*3</sup>	Vibration Acceleration Rate at Flange	49 m/s <sup>2</sup>			
Applicable SERVOPACKs		1R9D		3R5	5R4

\*1. A vibration class of V15 indicates a vibration amplitude of 15 μm maximum on the Servo Motor without a load at the rated motor speed.

\*2. The shock resistance for shock in the vertical direction when the Servo Motor is mounted with the shaft in a horizontal position is given in the above table.

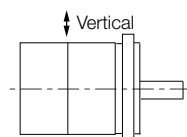

Shock Applied to the Servo Motor

\*3. The vertical, side-to-side, and front-to-back vibration resistance for vibration in three directions when the Servo Motor is mounted with the shaft in a horizontal position is given in the above table. The strength of the vibration that the Servo Motor can withstand depends on the application. Always check the vibration acceleration rate that is applied to the Servo Motor with the actual equipment.

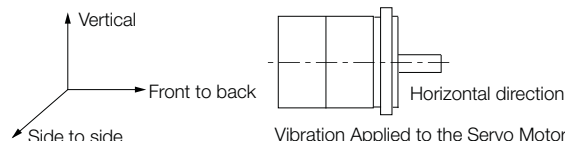

Vibration Applied to the Servo Motor

\*4. If the surrounding air temperature will exceed 40°C, refer to the following section.

 **Applications Where the Surrounding Air Temperature of the Servo Motor Exceeds 40°C (page 63)**

\*5. If the altitude will exceed 1,000 m, refer to the following section.

 **Applications Where the Altitude of the Servo Motor Exceeds 1,000 m (page 64)**

## Ratings of Servo Motors (400 V Models)

Voltage		400 V				
Model SGM7A-		02D	04D	08D	10D	
Rated Output <sup>*1</sup>	W	200	400	750	1000	
Rated Torque <sup>*1, *2</sup>	N•m	0.637	1.27	2.39	3.18	
Instantaneous Maximum Torque <sup>*1</sup>	N•m	2.23	4.46	8.36	11.1	
Rated Current <sup>*1</sup>	Arms	1.2	1.2	2.2	3.2	
Instantaneous Maximum Current <sup>*1</sup>	Arms	5.1	4.9	8.5	12.0	
Rated Motor Speed <sup>*1</sup>	min <sup>-1</sup>	3000				
Maximum Motor Speed <sup>*1</sup>	min <sup>-1</sup>	6000				
Torque Constant	N•m/Arms	0.556	1.11	1.16	1.07	
Motor Moment of Inertia	×10 <sup>-4</sup> kg•m <sup>2</sup>	0.139 (0.209)	0.216 (0.286)	0.775 (0.995)	0.971 (1.15)	
Rated Power Rate <sup>*1</sup>	kW/s	29.2 (19.4)	74.7 (56.3)	73.7 (59.8)	104 (87.9)	
Rated Angular Acceleration Rate <sup>*1</sup>	rad/s <sup>2</sup>	45800 (30400)	58700 (44400)	30800 (25000)	32700 (27600)	
Heat Sink Size (Aluminum)	mm	250 × 250 × 6			300 × 300 × 12	
Protective Structure <sup>*3</sup>		Totally enclosed, self-cooled, IP67				
Holding Brake Specifications <sup>*4</sup>	Rated Voltage	V	24 VDC±10%			
	Capacity	W	6	6.5		
	Holding Torque	N•m	0.637	1.27	2.39	3.18
	Coil Resistance	Ω(at 20°C)	96±10%		88.6±10%	
	Rated Current	A (at 20°C)	0.25		0.27	
	Time Required to Release Brake	ms	60		80	
	Time Required to Brake	ms	100			
Allowable Load Moment of Inertia (Motor Moment of Inertia Ratio)	Standard	30 times	20 times			
	With External Regenerative Resistor and Dynamic Brake Resistor Connected	30 times	20 times	30 times		
Allowable Shaft Loads <sup>*5</sup>	LF	mm	25		35	
	Allowable Radial Load	N	245		392	
	Allowable Thrust Load	N	74		147	

Note: 1. The values in parentheses are for Servo Motors with Holding Brakes.

2. Refer to the following section for footnotes \*1 to \*5

 **Notes for Ratings of Servo Motor (page 54)**

### Ratings of Gear Motors (200 V Models)

Gear Motor Model Number	Base Servo Motor Model (SGM7A-)	Gear Ratio	Gearing Efficiency % <sup>1</sup>	Rated Speed (RPM)	Max Speed (RPM)	Rated Torque (Nm) <sup>2</sup>	Peak Torque (Nm) <sup>2</sup>	Motor Inertia (x10 <sup>-4</sup> kg-m <sup>2</sup> )	Gear-head Inertia (x10 <sup>-4</sup> kg-m <sup>2</sup> )	Allowable Radial Load (N)	Allowable Axial Load (N)	Backlash (arc-min)	Protection Class	
S7A01A□ -VL050-03	01A7D6□	3:1	95	1000	2000	0.906	3.16	0.0337 (0.0447)	0.053	710	640	5	IP65	
S7A01A□ -VL050-05		5:1		600	1200	1.51	5.27		0.036					
S7A01A□ -VL050-10		10:1		300	600	3.02	10.5		0.030					
S7A01A□ -VL050-25		25:1	90	120	240	7.16	18.0 <sup>3</sup>		0.034					
S7A01A□ -VL070-50		50:1		60	120	14.3	50.0		0.030	1200	1100	5		
S7A02A□ -VL050-03	02A7D6□	3:1	95	1000	2000	1.82	6.36	0.139 (0.209)	0.091	710	640	5		
S7A02A□ -VL050-05		5:1		600	1200	3.03	10.6		0.074					
S7A02A□ -VL070-10		10:1		300	600	6.05	12.0 <sup>3</sup>		0.140					
S7A02A□ -VL070-25		25:1	90	120	240	14.3	50.2		0.130					
S7A02A□ -VL070-50		50:1		60	120	28.7	50.0 <sup>3</sup>		0.130	1200	1100			
S7A04A□ -VL050-03	04A7D6□	3:1	95	1000	2000	3.62	12.7	0.216 (0.286)	0.091	710	640			5
S7A04A□ -VL050-05		5:1		600	1200	6.03	18.0 <sup>3</sup>		0.074					
S7A04A□ -VL070-10		10:1		300	600	12.1	35.0 <sup>3</sup>		0.140					
S7A04A□ -VL070-25		25:1	90	120	240	28.6	50.0 <sup>3</sup>		0.130					
S7A04A□ -VL090-50		50:1		60	120	57.2	125 <sup>3</sup>		0.250	2400	2200			
S7A08A□ -VL070-03	08A7D6□	3:1	95	1000	2000	6.81	23.8	0.775 (0.955)	0.430	1200	1100		5	
S7A08A□ -VL070-05		5:1		600	1200	11.4	39.7		0.360					
S7A08A□ -VL090-10		10:1		300	600	22.7	79.4		0.750					
S7A08A□ -VL090-25		25:1	90	120	240	53.8	125 <sup>3</sup>		0.710					
S7A08A□ -VL120-50		50:1		60	120	108	330 <sup>3</sup>		0.730	4300	3900			
S7A10A□ -VL070-03	10A7D6□	3:1	95	1000	2000	9.06	31.6	0.971 (1.150)	0.430	1200	1100	5		
S7A10A□ -VL070-05		5:1		600	1200	15.1	52.7		0.360					
S7A10A□ -VL090-10		10:1		300	600	30.2	80 <sup>3</sup>		0.750					
S7A10A□ -VL090-25		25:1	90	120	240	71.6	125 <sup>3</sup>		0.710					
S7A10A□ -VL120-50		50:1		60	120	143	330 <sup>3</sup>		0.730	4300	3900			
S7A15A□ -VL090-03	15A7D6□	3:1	95	1000	2000	14.0	41.9	2.000 (2.250)	3.200	2400	2200			5
S7A15A□ -VL090-05		5:1		600	1200	23.3	69.8		2.900					
S7A15A□ -VL090-10		10:1		300	600	46.6	80 <sup>3</sup>		2.800					
S7A15A□ -VL120-25		25:1	90	120	240	110	331		2.800					
S7A15A□ -VL120-50		50:1		60	120	180 <sup>3</sup>	330 <sup>3</sup>		2.700	4300	3900			
S7A20A□ -VL090-03	20A7D6□	3:1	95	1000	2000	18.1	54.4	2.470 (2.720)	3.20	2400	2200		5	
S7A20A□ -VL090-05		5:1		600	1200	30.2	90.7		2.90					
S7A20A□ -VL120-10		10:1		300	600	60.4	181		3.00					
S7A20A□ -VL120-25		25:1	90	120	240	143 <sup>3</sup>	330 <sup>3</sup>		2.80					
S7A20A□ -VL155-50		50:1		40 <sup>3</sup>	80 <sup>3</sup>	286 <sup>3</sup>	700 <sup>3</sup>		2.80	9100	8200			
S7A25A□ -VL090-03	25A7D6□	3:1	95	1000	2000	22.7	68.1	3.190 (3.440)	3.20	2400	2200	5		
S7A25A□ -VL090-05		5:1		600	1200	37.8	114		2.90					
S7A25A□ -VL120-10		10:1		300	600	75.6	227		3.00					
S7A25A□ -VL120-25		25:1	90	120	240	179 <sup>3</sup>	330 <sup>3</sup>		2.80					
S7A25A□ -VL155-50		50:1		40 <sup>3</sup>	80 <sup>3</sup>	358 <sup>3</sup>	700 <sup>3</sup>		2.80	9100	8200			
S7A30A□ -VL090-03	30A7D6□	3:1	95	1000	2000	27.9	83.8	7.000 (9.200)	3.20	2400	2200			5
S7A30A□ -VL090-05		5:1		600	1200	46.6	125 <sup>3</sup>		2.90					
S7A30A□ -VL120-10		10:1		300	600	93.1	225 <sup>3</sup>		3.00					
S7A30A□ -VL120-25		25:1	90	120	240	180 <sup>3</sup>	330 <sup>3</sup>		2.80					
S7A30A□ -VL155-50		50:1		40 <sup>3</sup>	80 <sup>3</sup>	360 <sup>3</sup>	700 <sup>3</sup>		2.80	9100	8200			
S7A40A□ -VL090-03	40A7D6□	3:1	95	1000	2000	35.9	80 <sup>3</sup>	9.600 (11.80)	3.20	2400	2200		5	
S7A40A□ -VL090-05		5:1		600	1200	59.9	125 <sup>3</sup>		2.90					
S7A40A□ -VL120-10		10:1		300	600	120	225 <sup>3</sup>		3.00					
S7A40A□ -VL155-25		25:1	90	80 <sup>3</sup>	160 <sup>3</sup>	284	700 <sup>3</sup>		3.10					
S7A40A□ -VL205-50		50:1		30 <sup>3</sup>	60 <sup>3</sup>	567	1400 <sup>3</sup>		3.10	15000	14000			

## Rotary Servo Motors

### SGM7A

Gear Motor Model Number	Base Servo Motor Model (SGM7A-)	Gear Ratio	Gearing Efficiency <sup>*1</sup>	Rated Speed (RPM)	Max Speed (RPM)	Rated Torque (Nm) <sup>*2</sup>	Peak Torque (Nm) <sup>*2</sup>	Motor Inertia (x10 <sup>-4</sup> kg-m <sup>2</sup> )	Gear-head Inertia (x10 <sup>-4</sup> kg-m <sup>2</sup> )	Allowable Radial Load (N)	Allowable Axial Load (N)	Backlash (arc-min)	Protection Class		
S7A50A□ -VL090-03	50A7D6□	3:1	95	1000	2000	45.0	80 <sup>*3</sup>	12.30 (14.50)	3.20	2400	2200	5	IP65		
S7A50A□ -VL090-05		5:1		600	1200	75.1	125 <sup>*3</sup>		2.90						
S7A50A□ -VL155-10		10:1		200 <sup>*3</sup>	400 <sup>*3</sup>	150	452		2.80	9100	8200				
S7A50A□ -VL155-25		25:1	80 <sup>*3</sup>	160 <sup>*3</sup>	356	700 <sup>*3</sup>	3.10								
S7A50A□ -VL205-50		50:1	30 <sup>*3</sup>	60 <sup>*3</sup>	711	1400 <sup>*3</sup>	3.10		15000	14000					
S7A70A-VL120-03	70A7D61	3:1	95	1000	2000	63.6	154	12.30	5.30	4300	3900			5	IP65
S7A70A-VL120-05		5:1		600	1200	106	257		3.60						
S7A70A-VL155-10		10:1		200 <sup>*3</sup>	400 <sup>*3</sup>	212	513		2.80	9100	8200				
S7A70A-VL205-25		25:1	60 <sup>*3</sup>	120 <sup>*3</sup>	502	1215	4.20		15000	14000					
S7A70A-VL235-50		50:1	30 <sup>*3</sup>	60 <sup>*3</sup>	1026	2484	12.00								

Note: The values in parentheses are for Servo Motors with Holding Brakes (indicated by value of □ in model numbers).

\*1. The gear efficiency depends on operating conditions such as the output torque, motor speed, and temperature.

\*2. The gear motor output torque is expressed by the following formula: Output Torque = (Servo Motor Output Torque) x (Gearing Ratio) x (Gearing Efficiency). The values in the table are typical values for the rated torque, rated motor speed, and a surrounding air temperature of 25°C. They are reference values only.

\*3. The output torque of the gear motor is limited by the mechanical limit of the gear head. Operation above this limit could result in premature failure of the gear motor.



Important

During operation of the gear motor, losses due to inefficiencies of the gearing mechanism are generated. The losses vary as the conditions for gear motor torque and speed change. Temperature rise can vary based on the mechanical inefficiencies and the heat dissipation conditions. For heat dissipation conditions, check the gear and motor temperatures with the actual equipment. If operating temperatures are too high, implement the following measures.

- Decrease the load ratio.
- Change the heat dissipation conditions.
- Use forced-air cooling for the motor with a cooling fan or other means.

## Ratings of Gear Motors (400 V Models)

Gear Motor Model Number	Base Servo Motor Model (SGM7A-)	Gear Ratio	Gearing Efficiency *1	Rated Speed (RPM)	Max Speed (RPM)	Rated Torque (Nm) <sup>*2</sup>	Peak Torque (Nm) <sup>*2</sup>	Motor Inertia (x10 <sup>-4</sup> kg-m <sup>2</sup> )	Gear-head Inertia (x10 <sup>-4</sup> kg-m <sup>2</sup> )	Allowable Radial Load (N)	Allowable Axial Load (N)	Backlash (arc-min)	Protection Class
S7A02D□ -VL050-03	02D7F6□	3:1	95	1000	2000	1.82	6.36	0.139 (0.209)	0.091	710	640	5	IP65
S7A02D□ -VL050-05		5:1		600	1200	3.03	10.6		0.074				
S7A02D□ -VL050-10		10:1		300	600	6.05	12.0 <sup>*3</sup>		0.140				
S7A02D□ -VL070-25		25:1	90	120	240	14.3	50.2		0.130				
S7A02D□ -VL070-50		50:1		60	120	28.7	50.0 <sup>*3</sup>		0.130				
S7A04D□ -VL050-03	04D7F6□	3:1	95	1000	2000	3.62	12.7	0.216 (0.286)	0.091	710	640		
S7A04D□ -VL050-05		5:1		600	1200	6.03	18.0 <sup>*3</sup>		0.074				
S7A04D□ -VL070-10		10:1		300	600	12.1	35.0 <sup>*3</sup>		0.140				
S7A04D□ -VL070-25		25:1	90	120	240	28.6	50.0 <sup>*3</sup>		0.130				
S7A04D□ -VL090-50		50:1		60	120	57.2	125 <sup>*3</sup>		0.250	2400	2200		
S7A08D□ -VL070-03	08D7F6□	3:1	95	1000	2000	6.81	23.8	0.775 (0.955)	0.430	1200	1100		
S7A08D□ -VL070-05		5:1		600	1200	11.4	39.7		0.360				
S7A08D□ -VL090-10		10:1		300	600	22.7	79.4		0.750				
S7A08D□ -VL090-25		25:1	90	120	240	53.8	125 <sup>*3</sup>		0.710				
S7A08D□ -VL120-50		50:1		60	120	108	330 <sup>*3</sup>		0.730	4300	3900		
S7A10D□ -VL070-03	10D7F6□	3:1	95	1000	2000	9.06	31.6	0.971 (1.150)	0.430	1200	1100		
S7A10D□ -VL070-05		5:1		600	1200	15.1	52.7		0.360				
S7A10D□ -VL090-10		10:1		300	600	30.2	80 <sup>*3</sup>		0.750				
S7A10D□ -VL090-25		25:1	90	120	240	71.6	125 <sup>*3</sup>		0.710				
S7A10D□ -VL120-50		50:1		60	120	143	330 <sup>*3</sup>		0.730	4300	3900		

Note: The values in parentheses are for Servo Motors with Holding Brakes (indicated by value of □ in model numbers).

\*1. The gear efficiency depends on operating conditions such as the output torque, motor speed, and temperature.

\*2. The gear motor output torque is expressed by the following formula: Output Torque = (Servo Motor Output Torque) x (Gearing Ratio) x (Gearing Efficiency). The values in the table are typical values for the rated torque, rated motor speed, and a surrounding air temperature of 25°C. They are reference values only.

\*3. The output torque of the gear motor is limited by the mechanical limit of the gear head. Operation above this limit could result in premature failure of the gear motor.



Important

During operation of the gear motor, losses due to inefficiencies of the gearing mechanism are generated. The losses vary as the conditions for gear motor torque and speed change. Temperature rise can vary based on the mechanical inefficiencies and the heat dissipation conditions. For heat dissipation conditions, check the gear and motor temperatures with the actual equipment. If operating temperatures are too high, implement the following measures.

- Decrease the load ratio.
- Change the heat dissipation conditions.
- Use forced-air cooling for the motor with a cooling fan or other means.

## Servo Motor Overload Protection Characteristics

The overload detection level is set for hot start conditions with a Servo Motor surrounding air temperature of 40°C.

SGM7A-A5, -01, -C2, -02, -04, -06, -08, and -10

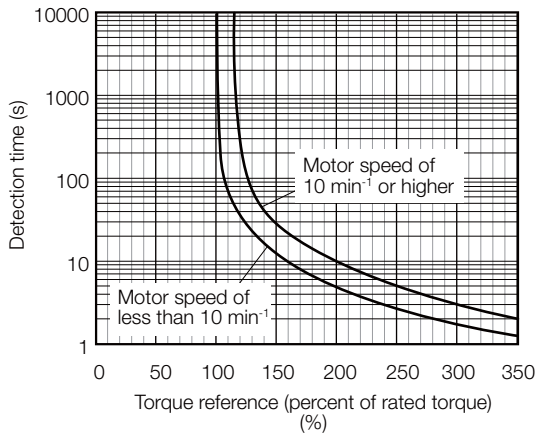

SGM7A-15, -20, -25, -30, -40, -50, and -70

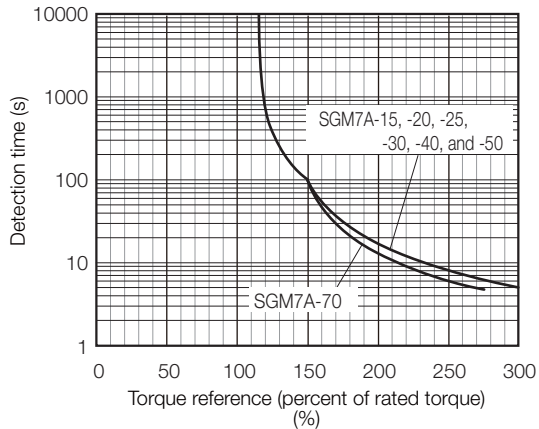

Note: The above overload protection characteristics do not mean that you can perform continuous duty operation with an output of 100% or higher. Use the Servo Motor so that the effective torque remains within the continuous duty zone given in *Torque-Motor Speed Characteristics (200 V Models -A5A to -10A)* on page 52 or in *Torque-Motor Speed Characteristics (200 V Models -15A to -70A)* on page 54.



## Allowable Load Moment of Inertia Scaling Factor for SERVOPACKs without Built-in Regenerative Resistors

The following graphs show the allowable load moment of inertia scaling factor of the motor speed for SERVOPACKs\* without built-in regenerative resistors when an External Regenerative Resistor is not connected.

If the Servo Motor exceeds the allowable load moment of inertia, an overvoltage alarm may occur in the SERVOPACK.

These graphs provide reference data for deceleration at the rated torque or higher with a 200-VAC power supply input.

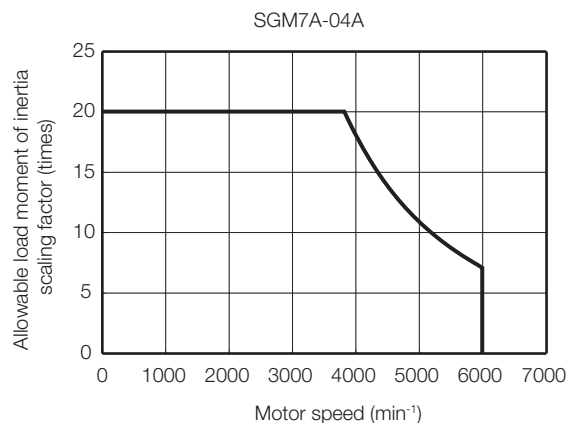
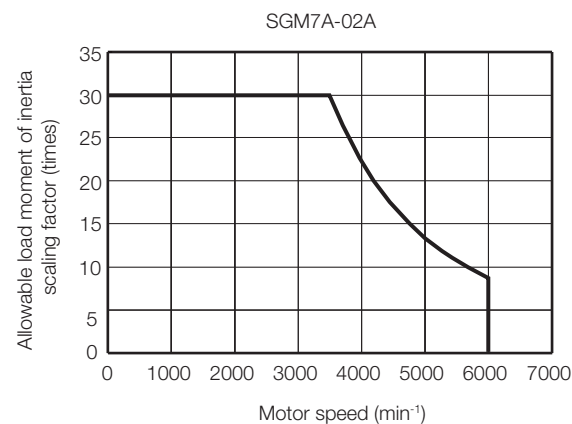
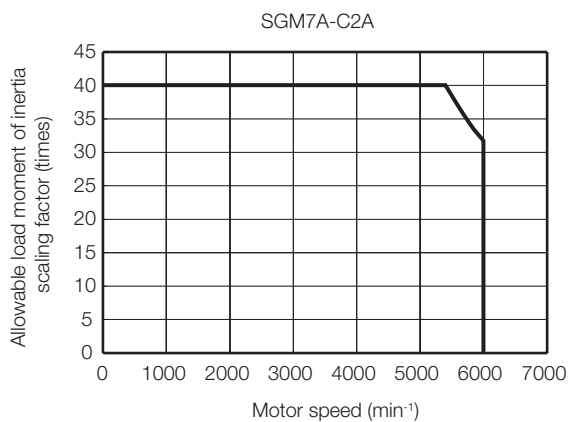
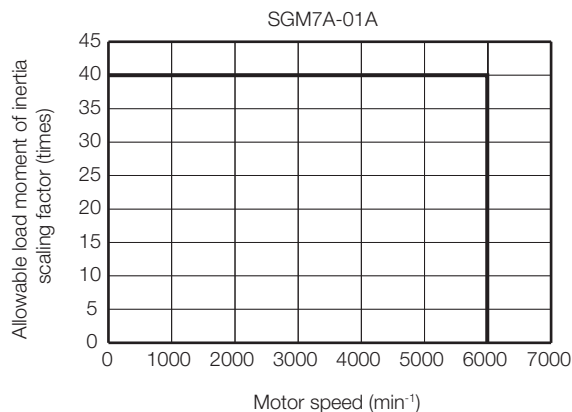
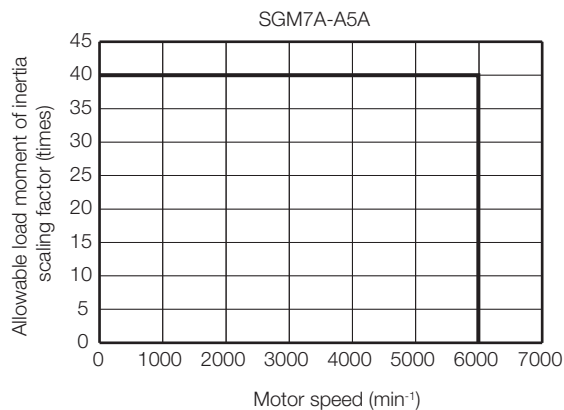

\* Applicable SERVOPACK models: SGD7S-R70A, -R90A, -1R6A, or -2R8A

## Servo Motor Heat Dissipation Conditions

The Servo Motor ratings are the continuous allowable values at a surrounding air temperature of 40°C when a heat sink is installed on the Servo Motor. If the Servo Motor is mounted on a small device component, the Servo Motor temperature may rise considerably because the surface for heat dissipation becomes smaller. Refer to the following graphs for the relation between the heat sink size and derating rate.

When using Servo Motors with derating, change the detection timing of overload warnings and overload alarms by referring to the motor overload detection level described in the following manual.

☞ *S-7-Series AC Servo Drive Rotary Servo Motor Product Manual* (Manual No.: SIEP S800001 36)

Note: The derating rates are applicable only when the average motor speed is less than or equal to the rated motor speed. If the average motor speed exceeds the rated motor speed, consult with your Yaskawa representative.



Important

The actual temperature rise depends on how the heat sink (i.e., the Servo Motor mounting section) is attached to the installation surface, what material is used for the Servo Motor mounting section, and the motor speed. Always check the Servo Motor temperature with the actual equipment.

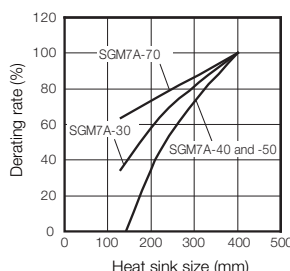
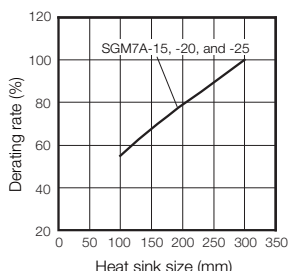
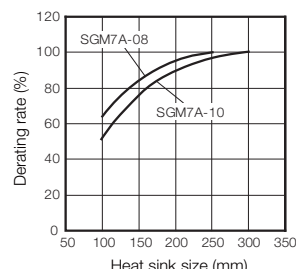
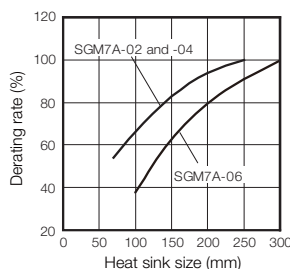
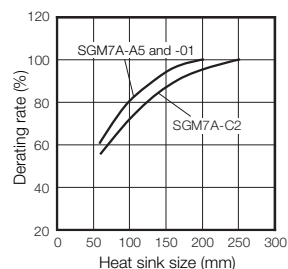

## Applications Where the Surrounding Air Temperature of the Servo Motor Exceeds 40°C

The Servo Motor ratings are the continuous allowable values at a surrounding air temperature of 40°C. If you use a Servo Motor at a surrounding air temperature that exceeds 40°C (60°C max.), apply a suitable derating rate from the following graphs.

When using Servo Motors with derating, change the detection timing of overload warnings and overload alarms by referring to the motor overload detection level described in the following manual.

📖 *Σ-7-Series AC Servo Drive Rotary Servo Motor Product Manual* (Manual No.: SIEP S800001 36)

Note: 1. Use the combination of the SERVOPACK and Servo Motor so that the derating conditions are satisfied for both the SERVOPACK and Servo Motor.

2. The derating rates are applicable only when the average motor speed is less than or equal to the rated motor speed. If the average motor speed exceeds the rated motor speed, consult with your Yaskawa representative.

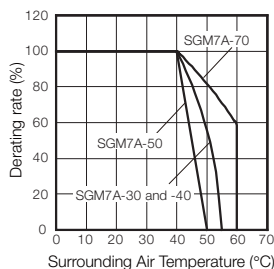
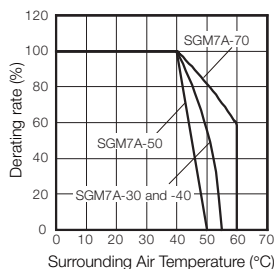
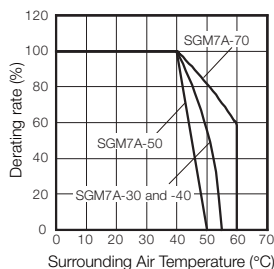
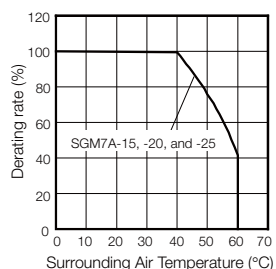
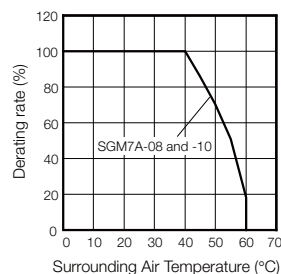
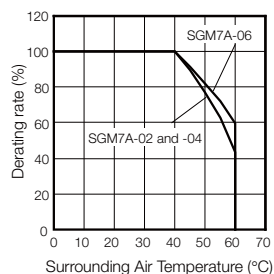
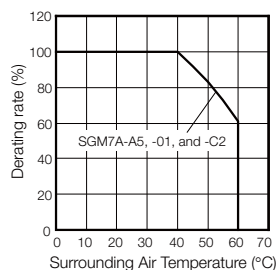

## Applications Where the Altitude of the Servo Motor Exceeds 1,000 m

The Servo Motor ratings are the continuous allowable values at an altitude of 1,000 m or less. If you use a Servo Motor at an altitude that exceeds 1,000 m (2,000 m max.), the heat dissipation effect of the air is reduced. Apply the appropriate derating rate from the following graphs.

When using Servo Motors with derating, change the detection timing of overload warnings and overload alarms by referring to the motor overload detection level described in the following manual.

☞ *Σ-7-Series AC Servo Drive Rotary Servo Motor Product Manual* (Manual No.: SIEP S80001 36)

Note: 1. Use the combination of the SERVOPACK and Servo Motor so that the derating conditions are satisfied for both the SERVOPACK and Servo Motor.

2. The derating rates are applicable only when the average motor speed is less than or equal to the rated motor speed. If the average motor speed exceeds the rated motor speed, consult with your Yaskawa representative.

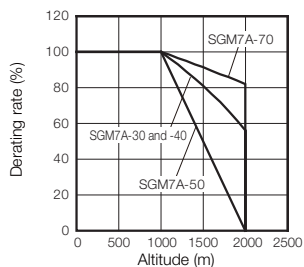
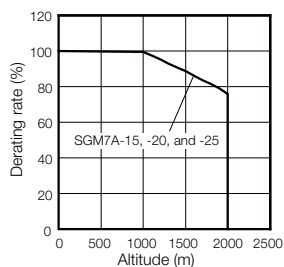
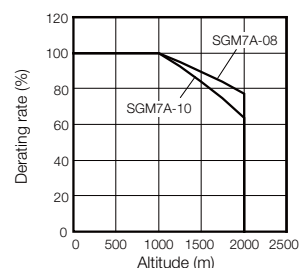
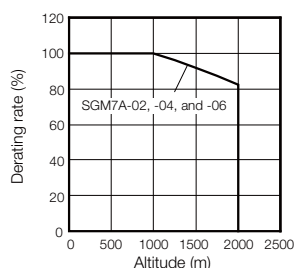
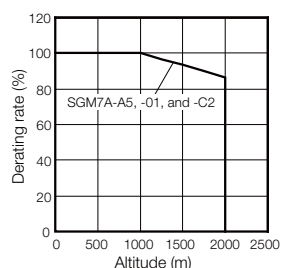

## External Dimensions

### Servo Motors

#### ◆ SGM7A-A5, -01, and -C2

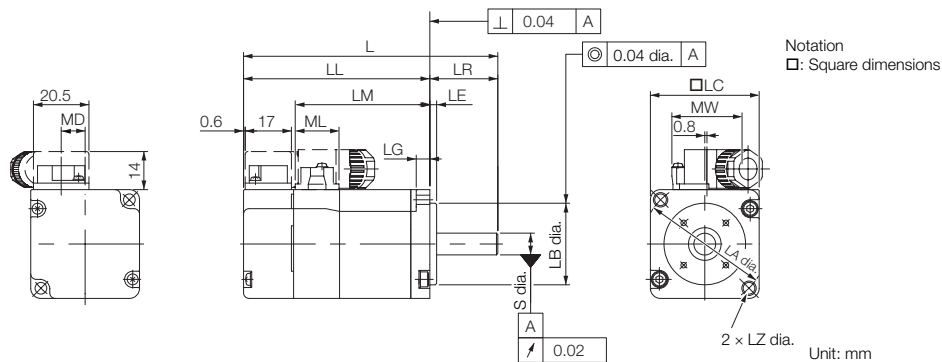

Model SGM7A-	L	LL	LM	Flange Dimensions							S
				LR	LE	LG	LC	LA	LB	LZ	
A5A□A2□	81.5 (122)	56.5 (97)	37.9	25	2.5	5	40	46	30 <sup>0</sup> <sub>-0.021</sub>	4.3	8 <sup>0</sup> <sub>-0.009</sub>
01A□A2□	93.5 (134)	68.5 (109)	49.9	25	2.5	5	40	46	30 <sup>0</sup> <sub>-0.021</sub>	4.3	8 <sup>0</sup> <sub>-0.009</sub>
C2A□A2□	105.5 (153.5)	80.5 (128.5)	61.9	25	2.5	5	40	46	30 <sup>0</sup> <sub>-0.021</sub>	4.3	8 <sup>0</sup> <sub>-0.009</sub>

Model SGM7A-	MD	MW	ML	Approx. Mass [kg]
A5A□A2□	8.8	25.8	16.1	0.3 (0.6)
01A□A2□	8.8	25.8	16.1	0.4 (0.7)
C2A□A2□	8.8	25.8	16.1	0.5 (0.8)

Note: 1. The values in parentheses are for Servo Motors with Holding Brakes.

2. Refer to the following section for detailed shaft end specifications.

☞ **Shaft End Specifications for SGM7A-A5 to -10 (200 V Models) (page 67)**

#### ■ Specifications of Options

##### • Oil Seal

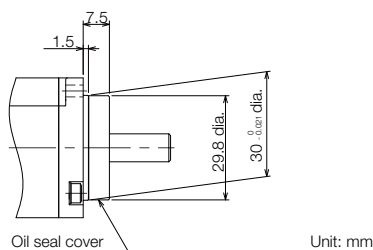

◆ SGM7A-02A to -10A (200 V Models)

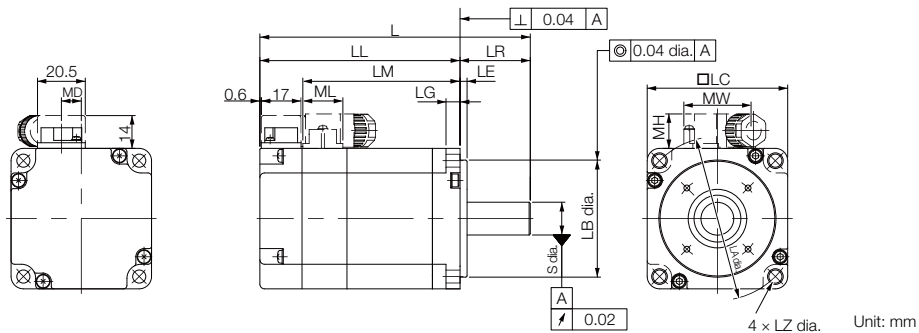

Model SGM7A-	L	LL	LM	Flange Dimensions							S
				LR	LE	LG	LC	LA	LB	LZ	
02A□A2□	99.5 (140)	69.5 (110)	51.2	30	3	6	60	70	50 <sup>0</sup> <sub>-0.025</sub>	5.5	14 <sup>0</sup> <sub>-0.011</sub>
04A□A2□	115.5 (156)	85.5 (126)	67.2	30	3	6	60	70	50 <sup>0</sup> <sub>-0.025</sub>	5.5	14 <sup>0</sup> <sub>-0.011</sub>
06A□A2□	137.5 (191.5)	107.5 (161.5)	89.2	30	3	6	60	70	50 <sup>0</sup> <sub>-0.025</sub>	5.5	14 <sup>0</sup> <sub>-0.011</sub>
08A□A2□	137 (184)	97 (144)	78.5	40	3	8	80	90	70 <sup>0</sup> <sub>-0.030</sub>	7	19 <sup>0</sup> <sub>-0.013</sub>
10A□A2□	162 (209)	122 (169)	103.5	40	3	8	80	90	70 <sup>0</sup> <sub>-0.030</sub>	7	19 <sup>0</sup> <sub>-0.013</sub>

Model SGM7A-	MD	MW	MH	ML	Approx. Mass [kg]
02A□A2□	8.5	28.7	14.7	17.1	0.8 (1.4)
04A□A2□	8.5	28.7	14.7	17.1	1.2 (1.8)
06A□A2□	8.5	28.7	14.7	17.1	1.6 (2.2)
08A□A2□	13.6	38	14.7	19.3	2.3 (2.9)
10A□A2□	13.6	38	14.7	19.3	3.1 (3.7)

Note: 1. The values in parentheses are for Servo Motors with Holding Brakes.

2. Refer to the following section for detailed shaft end specifications.

■ Shaft End Specifications for SGM7A-A5 to -10 (200 V Models) (page 67)

■ Specifications of Options

- Oil Seal

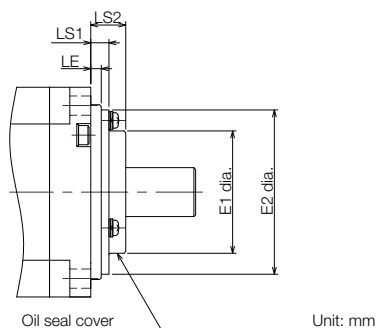

Model SGM7A-	Dimensions with Oil Seal			
	E1	E2	LS1	LS2
02A, 04A, 06A	35	47	5.2	10
08A, 10A	47	61	5.5	11

## Shaft End Specifications for SGM7A-A5 to -10 (200 V Models)

### ◆ SGM7A-□□□□□□□□

Code	Specification
2	Straight without key
6	Straight with key and tap for one location (Key slot is JIS B1301-1996 fastening type.)
B	With two flat seats

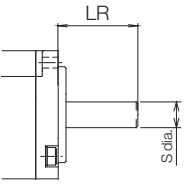
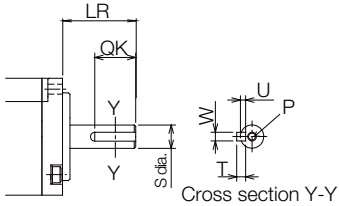
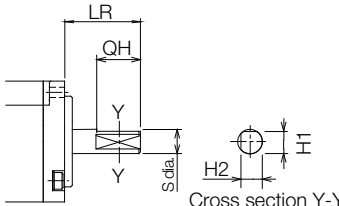
Shaft End Details	Servo Motor Model SGM7A-								
	A5	01	C2	02	04	06	08	10	
<b>Code: 2 (Straight without Key)</b>									
	LR	25			30			40	
	S	$8^{0}_{-0.009}$			$14^{0}_{-0.011}$			$19^{0}_{-0.013}$	
<b>Code: 6 (Straight with Key and Tap)</b>									
	LR	25			30			40	
	QK	14			14			22	
	S	$8^{0}_{-0.009}$			$14^{0}_{-0.011}$			$19^{0}_{-0.013}$	
	W	3			5			6	
	T	3			5			6	
	U	1.8			3			3.5	
	P	M3 × 6L			M5 × 8L			M6 × 10L	
<b>Code: B (with Two Flat Seats)</b>									
	LR	25			30			40	
	QH	15			15			22	
	S	$8^{0}_{-0.009}$			$14^{0}_{-0.011}$			$19^{0}_{-0.013}$	
	H1	7.5			13			18	
	H2	7.5			13			18	

◆ SGM7A-02D to -04D (400 V Model)

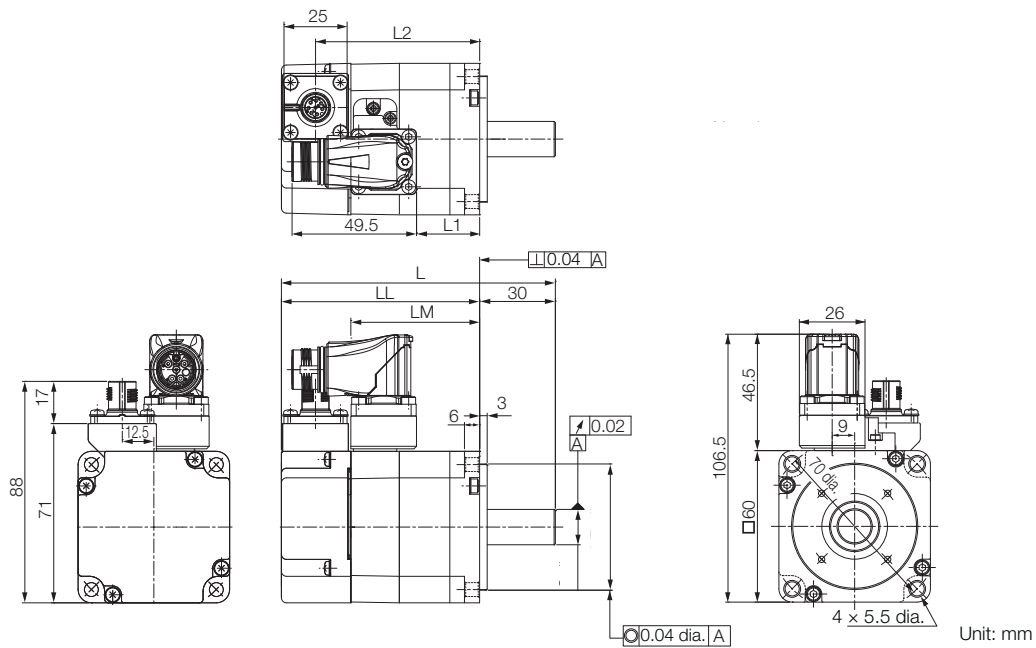

Model SGM7A-	L	LL	LM	LB	S	L1	L2	Approx. Mass [kg]
02D□F2□	108 (141.5)	78.5 (118.5)	51.2	50 <sup>0</sup> <sub>-0.025</sub>	14 <sup>0</sup> <sub>-0.011</sub>	25	65 (105)	0.9 (1.5)
04D□F2□	125 (165)	95 (135)	67.2	50 <sup>0</sup> <sub>-0.025</sub>	14 <sup>0</sup> <sub>-0.011</sub>	41.5	81.5 (121.5)	1.2 (1.8)

Note: 1. The values in parentheses are for Servo Motors with Holding Brakes.



◆ SGM7A-08D (400 V Model)

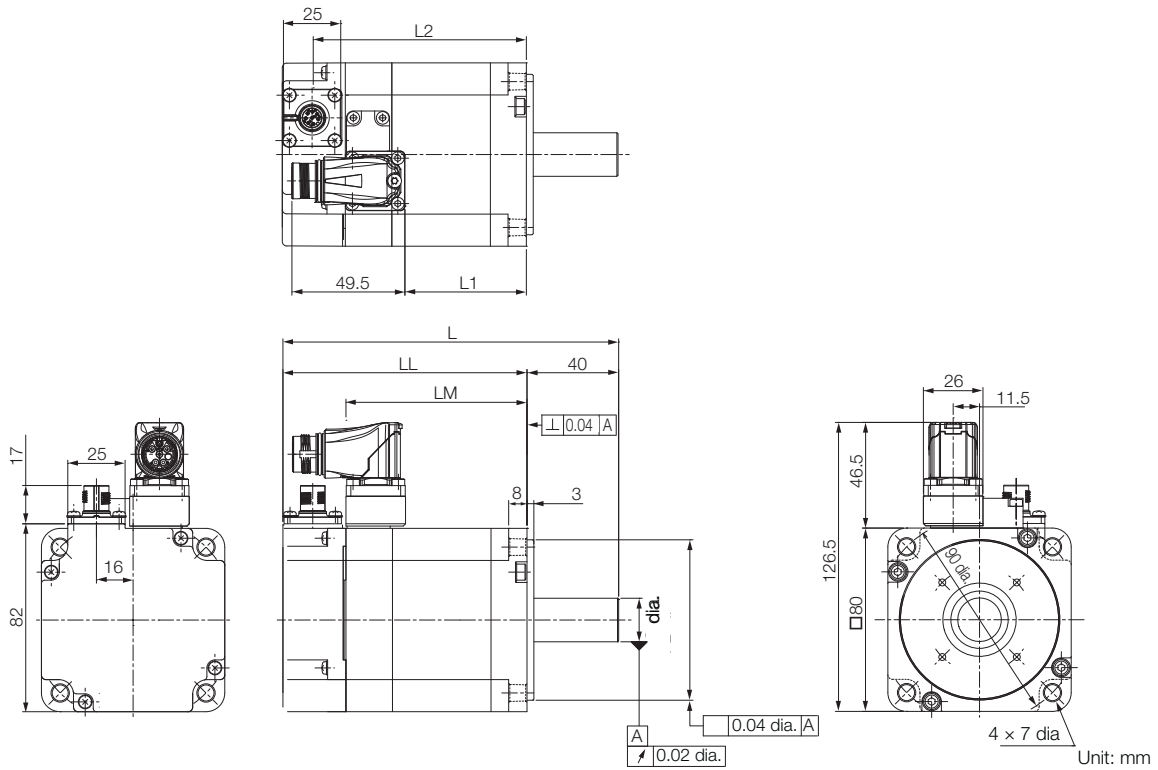

Model SGM7A-	L	LL	LM	LB	S	L1	L2	Approx. Mass [kg]
08D□F2□	146.5 (193.5)	106.5 (153.5)	79	70 <sup>0</sup> <sub>-0.030</sub>	19 <sup>0</sup> <sub>-0.013</sub>	53	93 (140)	2.4 (3.0)

Note: 1. The values in parentheses are for Servo Motors with Holding Brakes.

◆ SGM7A-10D (400 V Model)

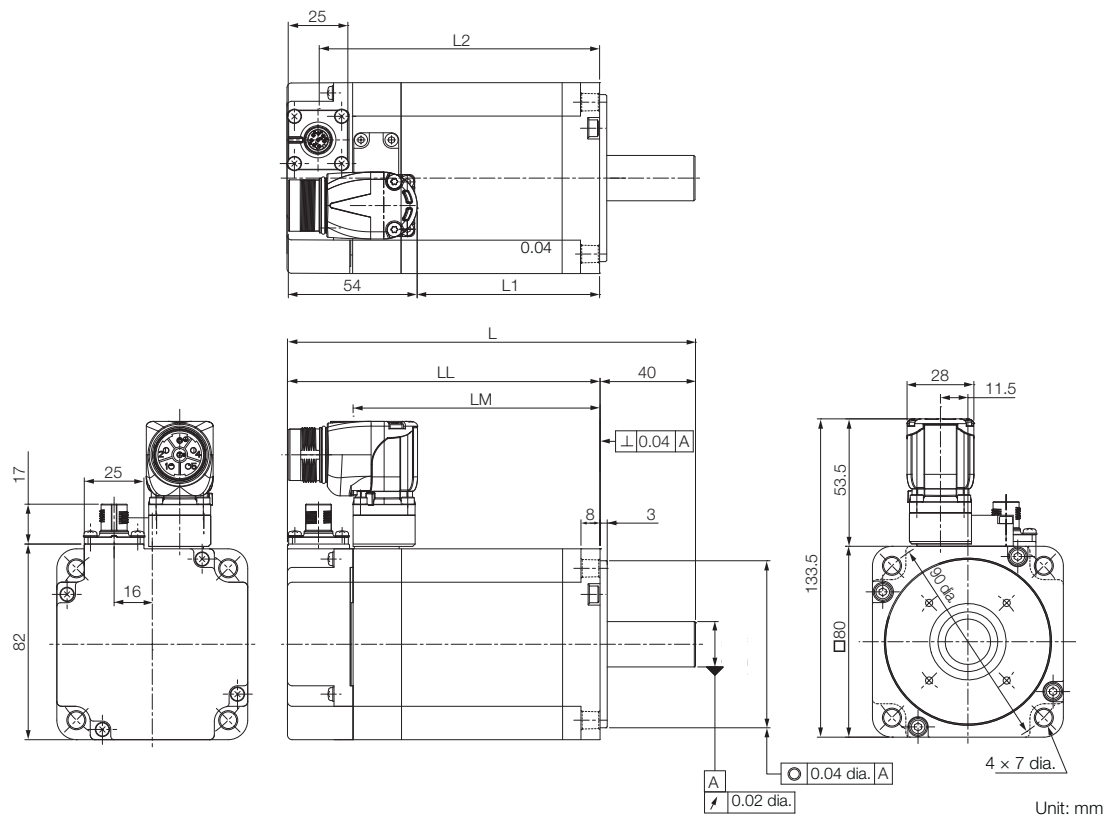

Model SGM7A-	L	LL	LM	LB	S	L1	L2	Approx. Mass [kg]
10D□F2□	171 (218)	131 (178)	103.5	70 <sup>0</sup> <sub>-0.030</sub>	19 <sup>0</sup> <sub>-0.013</sub>	77	117.5 (164.5)	3.2 (3.8)

Note: 1. The values in parentheses are for Servo Motors with Holding Brakes.

## Shaft End Specifications for SGM7A-02 to -10 (400 V Models)

### ◆ SGM7A-□□□□□□□□

Code	Specification
2	Straight without key
6	Straight with key and tap for one location (Key slot is JIS B1301-1996 fastening type.)

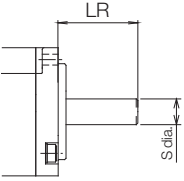
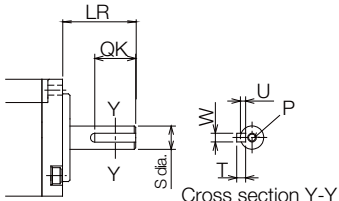
Shaft End Details	Servo Motor Model SGM7A-							
	A5	01	C2	02	04	06	08	10
Code: 2 (Straight without Key)								
	LR	25			30			40
	S	$8^{0}_{-0.009}$			$14^{0}_{-0.011}$			$19^{0}_{-0.013}$
Code: 6 (Straight with Key and Tap)								
	LR	25			30			40
	QK	14			14			22
	S	$8^{0}_{-0.009}$			$14^{0}_{-0.011}$			$19^{0}_{-0.013}$
	W	3			5			6
	T	3			5			6
	U	1.8			3			3.5
	P	M3 × 6L			M5 × 8L			M6 × 10L

## Servo Motors without Holding Brakes

### ◆ SGM7A-15, -20, and -25

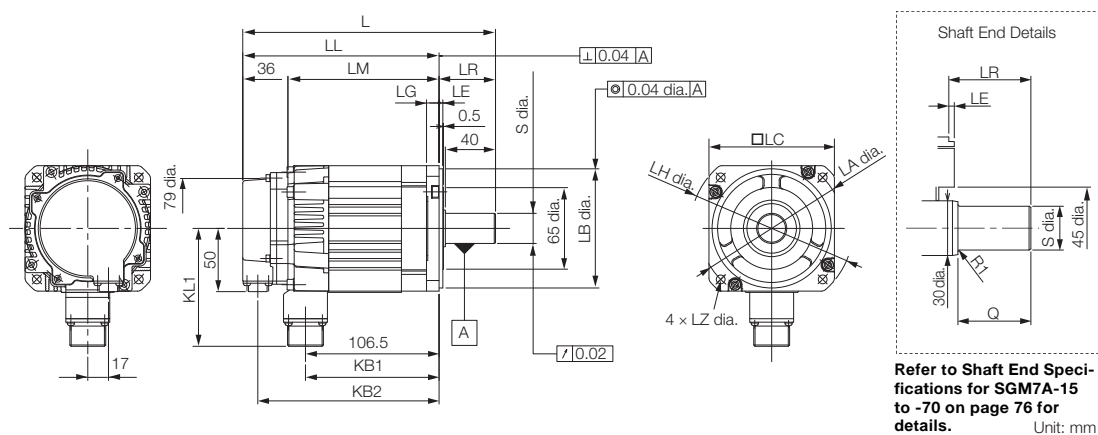

Model SGM7A-	L	LL	LM	LR	KB1	KB2	KL1
15A□A21	202	157	121	45	107	145	94
20A□A21	218	173	137	45	123	161	94
25A□A21	241	196	160	45	146	184	94

Model SGM7A-	Flange Dimensions							Shaft End Dimensions		Approx. Mass [kg]
	LA	LB	LC	LE	LG	LH	LZ	S	Q	
15A□A21	115	95 <sup>0</sup> <sub>-0.035</sub>	100	3	10	130	7	24 <sup>0</sup> <sub>-0.013</sub>	40	4.6
20A□A21	115	95 <sup>0</sup> <sub>-0.035</sub>	100	3	10	130	7	24 <sup>0</sup> <sub>-0.013</sub>	40	5.4
25A□A21	115	95 <sup>0</sup> <sub>-0.035</sub>	100	3	10	130	7	24 <sup>0</sup> <sub>-0.013</sub>	40	6.8

Note: Servo Motors with Oil Seals have the same dimensions.

◆ SGM7A-30, -40, and -50

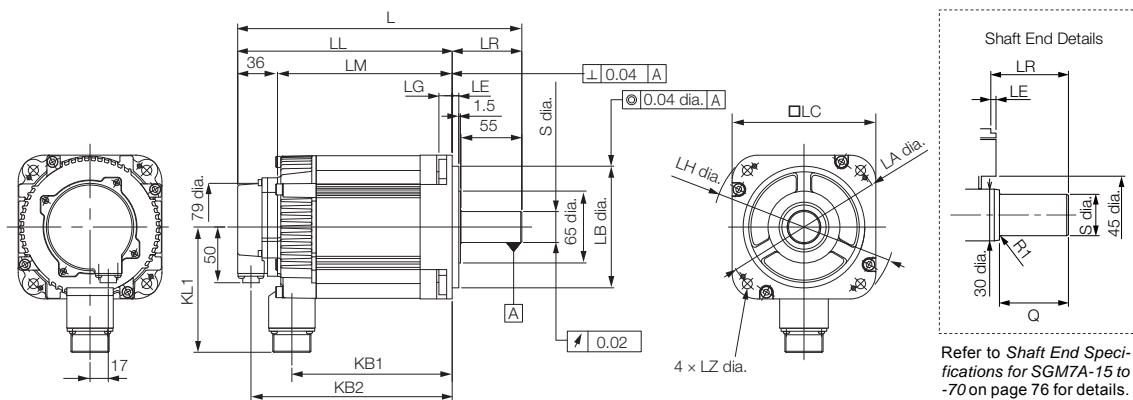

Unit: mm

Model SGM7A-	L	LL	LM	LR	KB1	KB2	KL1
30A□A21	257	194	158	63	145	182	114
40A□A21	296	233	197	63	184	221	114
50A□A21	336	273	237	63	224	261	114

Model SGM7A-	Flange Dimensions							Shaft End Dimensions		Approx. Mass [kg]
	LA	LB	LC	LE	LG	LH	LZ	S	Q	
30A□A21	145	110 <sup>0</sup> <sub>-0.035</sub>	130	6	12	165	9	28 <sup>0</sup> <sub>-0.013</sub>	55	10.5
40A□A21	145	110 <sup>0</sup> <sub>-0.035</sub>	130	6	12	165	9	28 <sup>0</sup> <sub>-0.013</sub>	55	13.5
50A□A21	145	110 <sup>0</sup> <sub>-0.035</sub>	130	6	12	165	9	28 <sup>0</sup> <sub>-0.013</sub>	55	16.5

Note: Servo Motors with Oil Seals have the same dimensions.  
Refer to the following section for information on connectors.

☞ SGM7A-15 to -50 without Holding Brakes (page 88)

◆ SGM7A-70

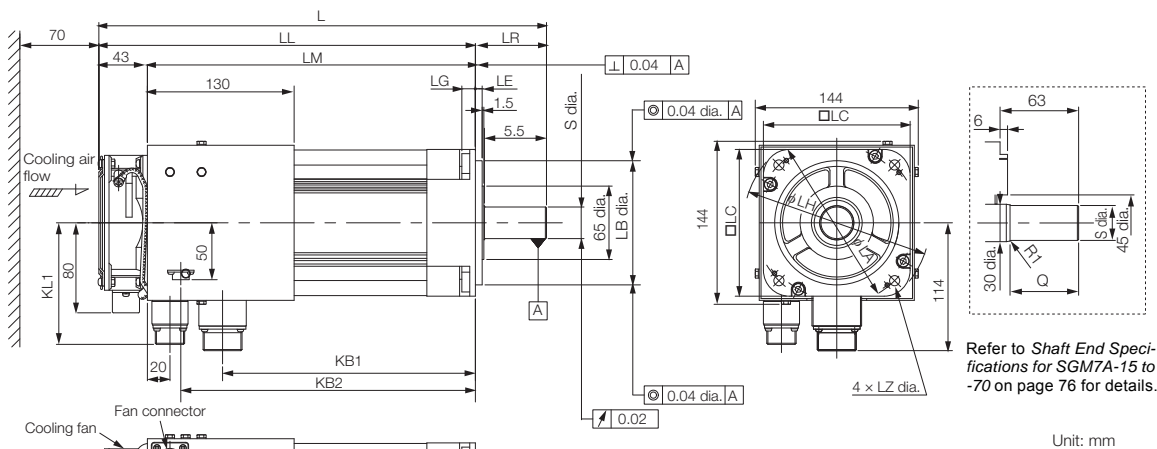

- Cooling Fan Specifications
  - Single-phase, 220 V
  - 50/60 Hz
  - 17/15 W
  - 0.11/0.09 A
- Specifications of Fan Operation Error Detector
  - Contact Capacity
    - Maximum allowable voltage: 350 V (AC/DC)
    - Maximum allowable current: 120 mA (AC/ DC)
    - Maximum controllable power: 360 mW
  - Alarm Contacts
    - ON for normal fan rotation.
    - OFF at 1,680 ± 100 min<sup>-1</sup> max.
    - OFF for 3 seconds at startup.

Model SGM7A-	L	LL	LM	LR	KB1	KB2	KL1
70A□A21	397	334	291	63	224	261	108

Model SGM7A-	Flange Dimensions							Shaft End Dimensions		Approx. Mass [kg]
	LA	LB	LC	LE	LG	LH	LZ	S	Q	
70A□A21	145	110 <sup>0</sup> <sub>-0.035</sub>	130	6	12	165	9	28 <sup>0</sup> <sub>-0.013</sub>	55	18.5

\* Leave a minimum space of 70 mm around the Servo Motor from walls and other equipment to allow for a sufficient amount of cooling air.

Note: Servo Motors with Oil Seals have the same dimensions.  
Refer to the following section for information on connectors.

◆ SGM7A-70 without Holding Brakes (page 88)

## Servo Motors with Holding Brakes

### ◆ SGM7A-15 to -50

- SGM7A-15 to -25

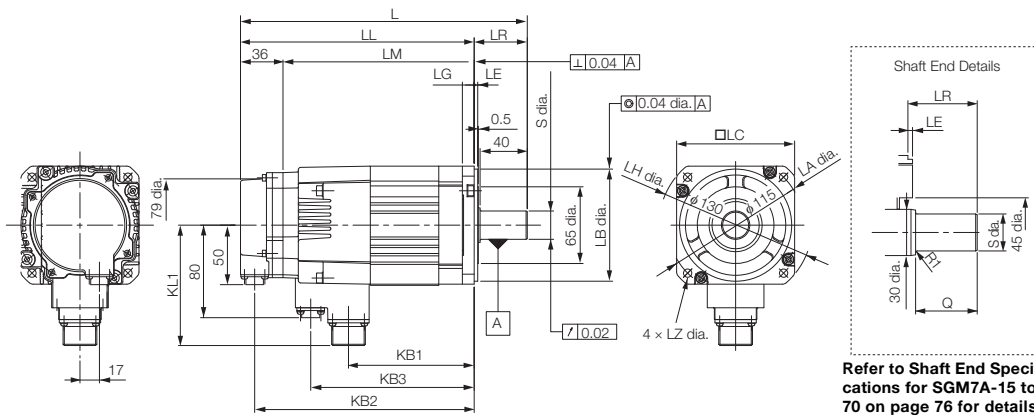

- SGM7A-30 to -50

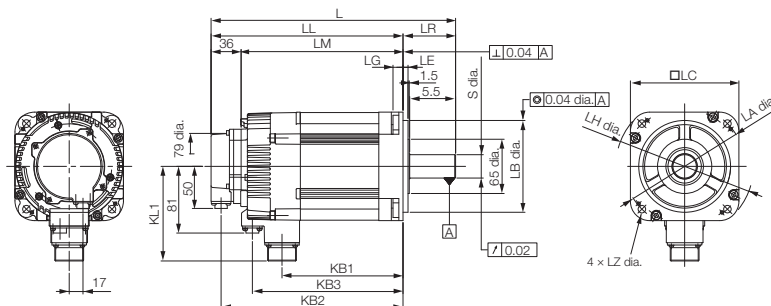

Model SGM7A-	L	LL	LM	LR	KB1	KB2	KB3	KL1
15A□A2C	243	198	162	45	107	186	139	102
20A□A2C	259	214	178	45	123	202	155	102
25A□A2C	292	247	211	45	156	235	188	102
30A□A2C	293	232	196	63	145	220	181	119
40A□A2C	332	269	233	63	184	257	220	119
50A□A2C	372	309	273	63	224	297	260	119

Model SGM7A-	Flange Dimensions							Shaft End Dimensions		Approx. Mass [kg]
	LA	LB	LC	LE	LG	LH	LZ	S	Q	
15A□A2C	115	95 <sup>0</sup> <sub>-0.035</sub>	100	3	10	130	7	24 <sup>0</sup> <sub>-0.013</sub>	40	6.0
20A□A2C	115	95 <sup>0</sup> <sub>-0.035</sub>	100	3	10	130	7	24 <sup>0</sup> <sub>-0.013</sub>	40	6.8
25A□A2C	115	95 <sup>0</sup> <sub>-0.035</sub>	100	3	10	130	7	24 <sup>0</sup> <sub>-0.013</sub>	40	8.7
30A□A2C	145	110 <sup>0</sup> <sub>-0.035</sub>	130	6	12	165	9	28 <sup>0</sup> <sub>-0.013</sub>	55	13
40A□A2C	145	110 <sup>0</sup> <sub>-0.035</sub>	130	6	12	165	9	28 <sup>0</sup> <sub>-0.013</sub>	55	16
50A□A2C	145	110 <sup>0</sup> <sub>-0.035</sub>	130	6	12	165	9	28 <sup>0</sup> <sub>-0.013</sub>	55	19

Note: Servo Motors with Oil Seals have the same dimensions.

Refer to the following section for information on connectors.

- ◆ SGM7A-15 to -50 with Holding Brakes (page 89)

## Shaft End Specifications for SGM7A-15 to -70

### ◆ SGM7A-□□□□□□□□

Code	Specification
2	Straight without key
6	Straight with key and tap for one location (Key slot is JIS B1301-1996 fastening type.)

Shaft End Details	Servo Motor Model SGM7A-						
	15	20	25	30	40	50	70
Code: 2 (Straight without Key)							
	LR	45			63		
	Q	40			55		
	S	$24^{0}_{-0.013}$			$28^{0}_{-0.013}$		
Code: 6 (Straight with Key and Tap)							
	LR	45			63		
	Q	40			55		
	QK	32			50		
	S	$24^{0}_{-0.013}$			$28^{0}_{-0.013}$		
	W	8					
	T	7					
	U	4					
	P	M8 screw, Depth: 16					



## Gear Motors

### ◆ Gear Motor Models: 100W, 200W, 400W (S7A01, S7A02, S7A04)

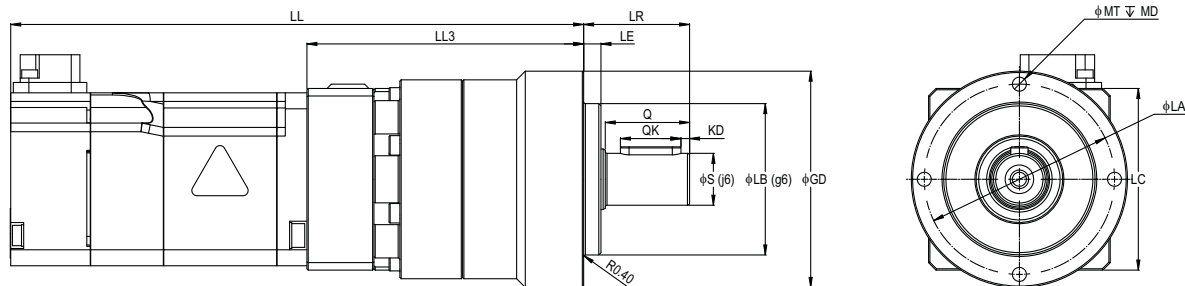

Shaft Detail (VL050 Models Only)

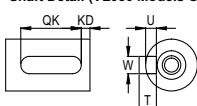

Shaft Detail (All Other Models)

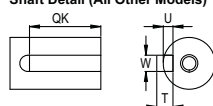

Model S7A	LL	LL3	LR	LE	φS	φLB	φGD	LC	φLA	φMT	MD	Q	QK	KD	W	U	T	
100 W Models																		
200 V	01A□ -VL050-03	133.5 (174)	65	24.5	4	12	35	50	42	44	M4	8	19.5	14	2	4	2.5	4
	01A□ -VL050-05																	
	01A□ -VL050-10																	
	01A□ -VL070-25	81.5	150 (190.5)	16	52	70	52	62	M5	10	28	22	0	5	3	5		
01A□ -VL070-50	95	163.5 (204)	36	5	16	52	70	52	62	M5	10	28	22	0	5	3	5	
200 W Models																		
200 V	02A□ -VL050-03	137.5 (178)	68	24.5	4	12	35	50	65	44	M4	8	19.5	14	2	4	2.5	4
	02A□ -VL050-05																	
	02A□ -VL070-10	80	36	5	16	52	70	62		M5	10	28	22	0	5	3	5	
	02A□ -VL070-25																	
	02A□ -VL070-50																	
400 V	02D□ -VL050-03	146.5 (186.5)	68	24.5	4	12	35	50	65	44	M4	8	19.5	14	2	4	2.5	4
	02D□ -VL050-05																	
	02D□ -VL070-10	80	36	5	16	52	70	62		M5	10	28	22	0	5	3	5	
	02D□ -VL070-25																	
	02D□ -VL070-50																	
400 W Models																		
200 V	04A□ -VL050-03	153.5 (194)	68	24.5	4	12	52	70	65	44	M4	8	19.5	14	2	4	2.5	4
	04A□ -VL050-05																	
	04A□ -VL070-10	80	36	5	16	68	90	62		M5	10	28	22	0	05	3	5	
	04A□ -VL070-25																	
	04A□ -VL090-50																	
400 V	04D□ -VL050-03	163 (203)	68	24.5	4	12	52	70	65	44	M4	8	19.5	14	2	4	2.5	4
	04D□ -VL050-05																	
	04D□ -VL070-10	80	36	5	16	68	90	62		M5	10	28	22	0	05	3	5	
	04D□ -VL070-25																	
	04D□ -VL090-50																	

Note: The values in parentheses are for Servo Motors with Holding Brakes.

◆ Gear Motor Models: 750W, 1.0kW, 1.5kW (S7A08, S7A10, S7A15)

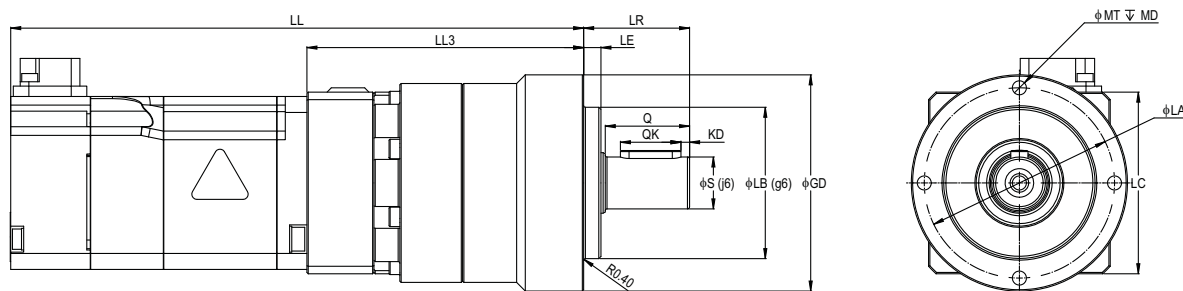

Shaft Detail (VL050 Models Only)

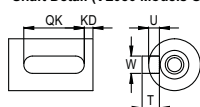

Shaft Detail (All Other Models)

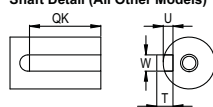

Model S7A	LL	LL3	LR	LE	φS	φLB	φGD	LC	φLA	φMT	MD	Q	QK	KD	W	U	T														
750 W Models																															
200 V	08A□ -VL070-03	191	94	36	5	16	52	70	80	M5	10	28	22	0	5	3	5														
	08A□ -VL070-05	(238)																													
	08A□ -VL090-10	204	107	46	7	22	68	90										80	M6	12	36	28		6	3.5	6					
	08A□ -VL090-25	226	129																												
	08A□ -VL120-50	241.5	144.5	70	9	32	90	120										108	M8	16	58	45		10	5	8					
400 V	08D□ -VL070-03	200.5	94	36	5	16	52	70	80	M5	10	28	22	0	5	3	5														
	08D□ -VL070-05	(247.5)																													
	08A□ -VL090-10	213.5	107	46	7	22	68	90										80	M6	12	36	28		6	3.5	6					
	08D□ -VL090-25	235.5	129																												
	08D□ -VL120-50	251	144.5	70	9	32	90	120										108	M8	16	58	45		10	5	8					
1.0 kW Models																															
200 V	10A□ -VL070-03	216	94	36	5	16	52	70	80	M5	10	28	22	0	5	3	5														
	10A□ -VL070-05	(263)																													
	10A□ -VL090-10	229	107	46	7	22	68	90										80	M6	12	36	28		6	3.5	6					
	10A□ -VL090-25	251	129																												
	10A□ -VL120-50	266.5	144.5	70	9	32	90	120										108	M8	16	58	45		10	5	8					
400 V	10D□ -VL070-03	225	94	36	5	16	52	70	80	M5	10	28	22	0	5	3	5														
	10D□ -VL070-05	(272)																													
	10A□ -VL090-10	238	107	46	7	22	68	90										80	M6	12	36	28		6	3.5	6					
	10D□ -VL090-25	(285)	129																												
	10D□ -VL120-50	260	144.5	70	9	32	90	120										108	M8	16	58	45		10	5	8					
1.5 kW Models																															
200 V	15A□ -VL090-03	276	119	46	7	22	68	90	100	M6	12	36	28	0	6	3.5	6														
	15A□ -VL090-05																	(317)													
	15A□ -VL090-10																														
	15A□ -VL090-25	313.5	156.5	70	9	32	90	120										80	M8	16	58	45		10	5	8					
	15A□ -VL120-50	(354.5)																													

Note: The values in parentheses are for Servo Motors with Holding Brakes.

◆ Gear Motor Models: 2.0 to 4.4kW (S7A20, S7A25, S7A30, S7A40)

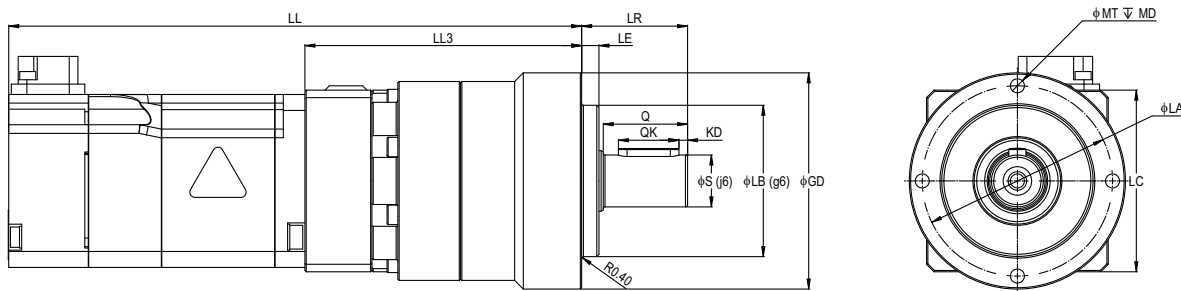

Shaft Detail (VL050 Models Only)

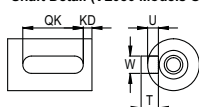

Shaft Detail (All Other Models)

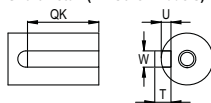

Model S7A	LL	LL3	LR	LE	φS	φLB	φGD	LC	φLA	φMT	MD	Q	QK	KD	W	U	T								
2.0 kW Models																									
200 V	20A□ -VL090-03	216 (263)	94	36	5	16	52	70	80	M5	10	28	22	0	5	3	5								
	20A□ -VL090-05	229 (276)	107	46	7	22	68	90										80	M6	12	36	28	6	3.5	6
	20A□ -VL120-10	251 (298)																							
	20A□ -VL120-25	266.5 (313.5)	144.5	70	9	32	90	120										108	M8	16	58	45	10	5	8
	20A□ -VL155-50	266.5 (313.5)																							
2.5 kW Models																									
200 V	25A□ -VL070-03	315 (366)	119	46	7	22	68	90	100	M6	12	36	28	0	6	3.5	6								
	25A□ -VL070-05	325 (376)	129	70	9	32	90	120										108	M8	16	58	45	10	5	8
	25A□ -VL090-10	352.5 (403.5)																							
	25A□ -VL090-25	377.5 (428.5)	181.5	97	12	40	120	155										140	M10	20	82	65	12	5	8
	25A□ -VL120-50	377.5 (428.5)																							
3.0 kW Models																									
200 V	30A□ -VL090-03	318 (356)	124	46	7	22	68	90	130	M6	12	36	28	0	6	3.5	6								
	30A□ -VL090-05	328 (366)	134	70	9	32	90	120										108	M8	16	58	45	10	5	8
	30A□ -VL120-10	355.5 (393.5)																							
	30A□ -VL120-25	380.5 (418.5)	186.5	97	12	40	120	155										140	M10	20	82	65	12	5	8
	30A□ -VL155-50	380.5 (418.5)																							
4.0 kW Models																									
200 V	40A□ -VL090-03	357 (393)	124	46	7	22	68	90	130	M6	12	36	28	0	6	3.5	6								
	40A□ -VL090-05	367 (403)	134	70	9	32	90	120										108	M8	16	58	45	10	5	8
	40A□ -VL120-10	419.5 (455.5)																							
	40A□ -VL155-25	449 (485)	216	100	15	55	160	205										184	M12	22	82	65	16	6	10
	40A□ -VL205-50	449 (485)																							

Note: The values in parentheses are for Servo Motors with Holding Brakes. 7.0kW motors not available with brake.

◆ Gear Motor Models: 5.0 to 7.0kW (S7A50, S7A70)

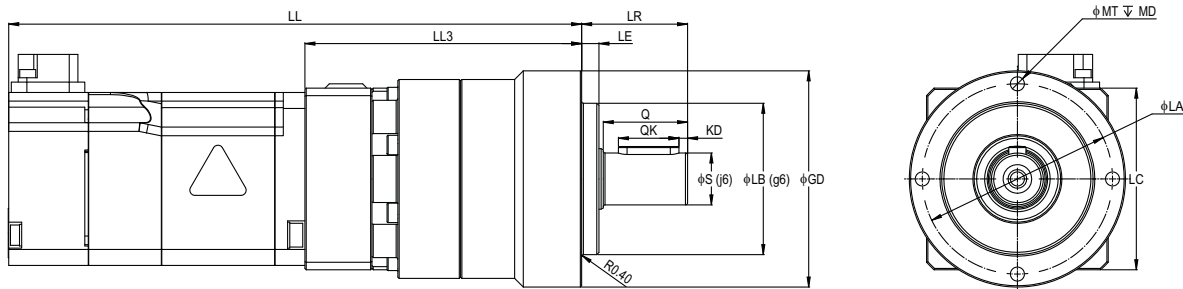

Shaft Detail (VL050 Models Only)

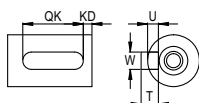

Shaft Detail (All Other Models)

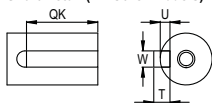

Model S7A	LL	LL3	LR	LE	φS	φLB	φGD	LC	φLA	φMT	MD	Q	QK	KD	W	U	T												
5.0 kW Models																													
200 V	50A□ -VL090-03	397	124	46	7	22	68	130	80	M6	12	36	28	0	6	3.5	6												
	50A□ -VL090-05	(433)	152	97	12	40	120		155	140	M10	20	82		65	12	5	8											
	50A□ -VL155-10	425																	186.5	15	55	160	205	184	M12	22	16	6	10
	50A□ -VL155-25	459.5																											
50A□ -VL205-50	489	216	100	15	55	160	205	184	M12	22	16	6	10																
7.0 kW Models																													
200 V	70A□ -VL120-03	468	134	70	9	32	90	130	108	M8	16	58	45	0	10	5	8												
	70A□ -VL120-05								140	M10	20	82	65		12														
	70A□ -VL155-10	486	152	97	12	40	120								155	184	M12	22	16	6	10								
	70A□ -VL205-25	550	216	100	15	55	160								205	210	M16	28	105	85	20	7.5	12						
70A□ -VL235-50	559.5	225.5	126	18	75	180	235	210	M16	28	105	85	20	7.5	12														

Note: The values in parentheses are for Servo Motors with Holding Brakes. 7.0kW motors not available with brake.

## Selecting Cables

### ◆ Cable Configurations

The cables shown below are required to connect a Servo Motor to a SERVOPACK.

Encoder Cable of 20 m or Less

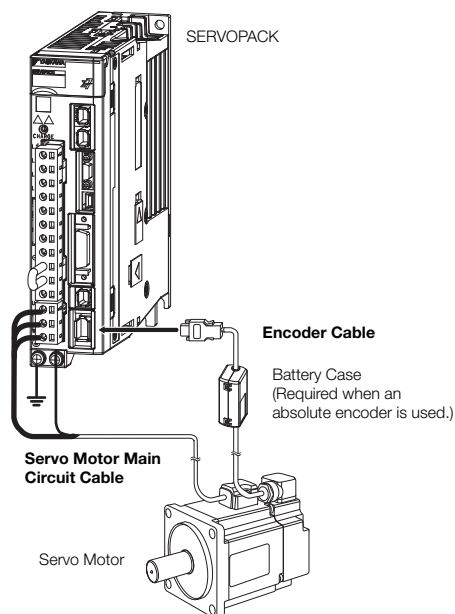

Encoder Cable of 30 m to 50 m (Relay Cable)

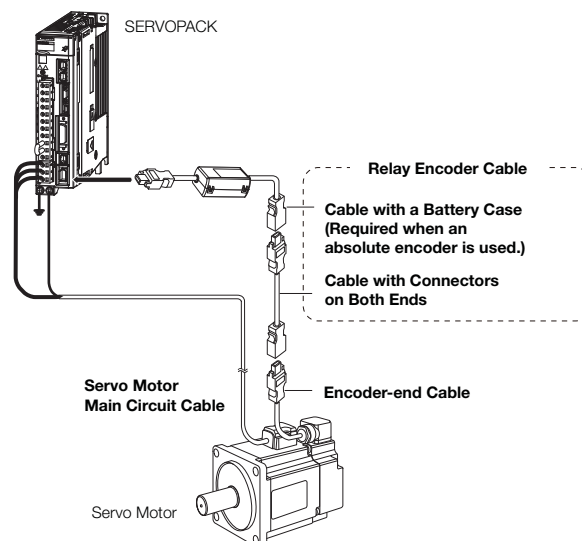

Note: 1. Cables with connectors on both ends that are compliant with an IP67 protective structure and European Safety Standards are not available from Yaskawa for the SGM7A-15A to SGM7A-30A Servo Motors. You must make such a cable yourself. Use the Connectors specified by Yaskawa for these Servo Motors. (These Connectors are compliant with the standards.) Yaskawa does not specify what wiring materials to use.

2. If the cable length exceeds 20 m, be sure to use a Relay Encoder Cable.
3. If you use a Servo Motor Main Circuit Cable that exceeds 20 m, the intermittent duty zone in the torque-motor speed characteristics will become smaller because the voltage drop increases.
4. Refer to the following manual for the following information.
  - Cable dimensional drawings and cable connection specifications
  - Order numbers and specifications of individual connectors for cables
  - Order numbers and specifications for wiring materials

📖 *Σ-7-Series AC Servo Drive Peripheral Device Selection Manual* (Manual No.: SIEP S800001 32)

 **Important** For the following Servo Motor models, there are different order numbers for the Servo Motor Main Circuit Cables and Encoder Cables depending on the cable installation direction. Confirm the order numbers before you order.

- SGM7A models SGM7A-A5 to SGM7A-10

Cable Installed toward Load

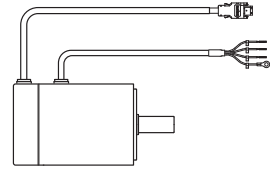

Cable Installed away from Load

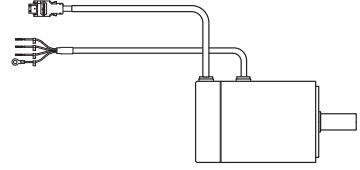

## Servo Motor Main Circuit Cables (200 V Models)

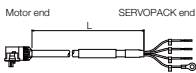
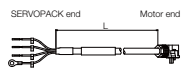
Servo Motor Model	Name	Length (L)	Order Number			Appearance		
			Standard Cable	Flexible Cable*	Flexible/Shielded			
SGM7A-A5 to -C2  50 W to 150 W (200V)	Power cable for Servo Motors without Holding Brakes	3 m	JZSP-C7M10F-03-E	JZSP-C7M12F-03-E	YAI-CSM21-03-P-E			
		5 m	JZSP-C7M10F-05-E	JZSP-C7M12F-05-E	YAI-CSM21-05-P-E			
		10 m	JZSP-C7M10F-10-E	JZSP-C7M12F-10-E	YAI-CSM21-10-P-E			
		15 m	JZSP-C7M10F-15-E	JZSP-C7M12F-15-E	YAI-CSM21-15-P-E			
		20 m	JZSP-C7M10F-20-E	JZSP-C7M12F-20-E	YAI-CSM21-20-P-E			
		30 m	JZSP-C7M10F-30-E	JZSP-C7M12F-30-E	YAI-CSM21-30-P-E			
		40 m	JZSP-C7M10F-40-E	JZSP-C7M12F-40-E	YAI-CSM21-40-P-E			
SGM7A-02 to -06  200 W to 600 W (200V)	Cable installed toward load	50 m	JZSP-C7M10F-50-E	JZSP-C7M12F-50-E	YAI-CSM21-50-P-E			
		3 m	JZSP-C7M20F-03-E	JZSP-C7M22F-03-E	YAI-CSM22-03-P-E			
		5 m	JZSP-C7M20F-05-E	JZSP-C7M22F-05-E	YAI-CSM22-05-P-E			
		10 m	JZSP-C7M20F-10-E	JZSP-C7M22F-10-E	YAI-CSM22-10-P-E			
		15 m	JZSP-C7M20F-15-E	JZSP-C7M22F-15-E	YAI-CSM22-15-P-E			
		20 m	JZSP-C7M20F-20-E	JZSP-C7M22F-20-E	YAI-CSM22-20-P-E			
		30 m	JZSP-C7M20F-30-E	JZSP-C7M22F-30-E	YAI-CSM22-30-P-E			
SGM7A-08 and -10  750 W, 1.0 kW (200V)	Cable installed toward load	40 m	JZSP-C7M20F-40-E	JZSP-C7M22F-40-E	YAI-CSM22-40-P-E			
		50 m	JZSP-C7M20F-50-E	JZSP-C7M22F-50-E	YAI-CSM22-50-P-E			
		3 m	JZSP-C7M30F-03-E	JZSP-C7M32F-03-E	YAI-CSM23-03-P-E			
		5 m	JZSP-C7M30F-05-E	JZSP-C7M32F-05-E	YAI-CSM23-05-P-E			
		10 m	JZSP-C7M30F-10-E	JZSP-C7M32F-10-E	YAI-CSM23-10-P-E			
		15 m	JZSP-C7M30F-15-E	JZSP-C7M32F-15-E	YAI-CSM23-15-P-E			
		20 m	JZSP-C7M30F-20-E	JZSP-C7M32F-20-E	YAI-CSM23-20-P-E			
SGM7A-A5 to -C2  50 W to 150 W (200V)	Power cable for Servo Motors without Holding Brakes	30 m	JZSP-C7M30F-30-E	JZSP-C7M32F-30-E	YAI-CSM23-30-P-E			
		40 m	JZSP-C7M30F-40-E	JZSP-C7M32F-40-E	YAI-CSM23-40-P-E			
		50 m	JZSP-C7M30F-50-E	JZSP-C7M32F-50-E	YAI-CSM23-50-P-E			
		SGM7A-02 to -06  200 W to 600 W (200V)	Cable installed away from load	3 m	JZSP-C7M10G-03-E		JZSP-C7M12G-03-E	N/A
				5 m	JZSP-C7M10G-05-E		JZSP-C7M12G-05-E	
				10 m	JZSP-C7M10G-10-E		JZSP-C7M12G-10-E	
				15 m	JZSP-C7M10G-15-E		JZSP-C7M12G-15-E	
20 m	JZSP-C7M10G-20-E			JZSP-C7M12G-20-E				
30 m	JZSP-C7M10G-30-E			JZSP-C7M12G-30-E				
40 m	JZSP-C7M10G-40-E			JZSP-C7M12G-40-E				
SGM7A-08 and -10  750 W, 1.0 kW (200V)	Cable installed away from load	50 m	JZSP-C7M10G-50-E	JZSP-C7M12G-50-E				
		3 m	JZSP-C7M20G-03-E	JZSP-C7M22G-03-E				
		5 m	JZSP-C7M20G-05-E	JZSP-C7M22G-05-E				
		10 m	JZSP-C7M20G-10-E	JZSP-C7M22G-10-E				
		15 m	JZSP-C7M20G-15-E	JZSP-C7M22G-15-E				
		20 m	JZSP-C7M20G-20-E	JZSP-C7M22G-20-E				
		30 m	JZSP-C7M20G-30-E	JZSP-C7M22G-30-E				
SGM7A-08 and -10  750 W, 1.0 kW (200V)	Cable installed away from load	40 m	JZSP-C7M20G-40-E	JZSP-C7M22G-40-E				
		50 m	JZSP-C7M20G-50-E	JZSP-C7M22G-50-E				
		3 m	JZSP-C7M30G-03-E	JZSP-C7M32G-03-E				
		5 m	JZSP-C7M30G-05-E	JZSP-C7M32G-05-E				
		10 m	JZSP-C7M30G-10-E	JZSP-C7M32G-10-E				
		15 m	JZSP-C7M30G-15-E	JZSP-C7M32G-15-E				
		20 m	JZSP-C7M30G-20-E	JZSP-C7M32G-20-E				
SGM7A-08 and -10  750 W, 1.0 kW (200V)	Cable installed away from load	30 m	JZSP-C7M30G-30-E	JZSP-C7M32G-30-E				
		40 m	JZSP-C7M30G-40-E	JZSP-C7M32G-40-E				
		50 m	JZSP-C7M30G-50-E	JZSP-C7M32G-50-E				

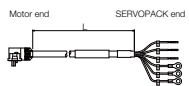
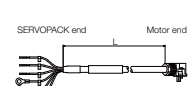
Servo Motor Model	Name	Length (L)	Order Number			Appearance		
			Standard Cable	Flexible Cable*	Flexible/Shielded			
SGM7A-A5 to -C2  50 W to 150 W (200V)	Power cable for Servo Motors with Holding Brakes	3 m	JZSP-C7M13F-03-E	JZSP-C7M14F-03-E	YAI-CSM31-03-P-E			
		5 m	JZSP-C7M13F-05-E	JZSP-C7M14F-05-E	YAI-CSM31-05-P-E			
		10 m	JZSP-C7M13F-10-E	JZSP-C7M14F-10-E	YAI-CSM31-10-P-E			
		15 m	JZSP-C7M13F-15-E	JZSP-C7M14F-15-E	YAI-CSM31-15-P-E			
		20 m	JZSP-C7M13F-20-E	JZSP-C7M14F-20-E	YAI-CSM31-20-P-E			
		30 m	JZSP-C7M13F-30-E	JZSP-C7M14F-30-E	YAI-CSM31-30-P-E			
		40 m	JZSP-C7M13F-40-E	JZSP-C7M14F-40-E	YAI-CSM31-40-P-E			
SGM7A-02 to -06  200 W to 600 W (200V)	Cable installed toward load	50 m	JZSP-C7M13F-50-E	JZSP-C7M14F-50-E	YAI-CSM31-50-P-E			
		3 m	JZSP-C7M23F-03-E	JZSP-C7M24F-03-E	YAI-CSM32-03-P-E			
		5 m	JZSP-C7M23F-05-E	JZSP-C7M24F-05-E	YAI-CSM32-05-P-E			
		10 m	JZSP-C7M23F-10-E	JZSP-C7M24F-10-E	YAI-CSM32-10-P-E			
		15 m	JZSP-C7M23F-15-E	JZSP-C7M24F-15-E	YAI-CSM32-15-P-E			
		20 m	JZSP-C7M23F-20-E	JZSP-C7M24F-20-E	YAI-CSM32-20-P-E			
		30 m	JZSP-C7M23F-30-E	JZSP-C7M24F-30-E	YAI-CSM32-30-P-E			
SGM7A-08 and -10  750 W, 1.0 kW (200V)	Cable installed toward load	40 m	JZSP-C7M23F-40-E	JZSP-C7M24F-40-E	YAI-CSM32-40-P-E			
		50 m	JZSP-C7M23F-50-E	JZSP-C7M24F-50-E	YAI-CSM32-50-P-E			
		3 m	JZSP-C7M33F-03-E	JZSP-C7M34F-03-E	YAI-CSM33-03-P-E			
		5 m	JZSP-C7M33F-05-E	JZSP-C7M34F-05-E	YAI-CSM33-05-P-E			
		10 m	JZSP-C7M33F-10-E	JZSP-C7M34F-10-E	YAI-CSM33-10-P-E			
		15 m	JZSP-C7M33F-15-E	JZSP-C7M34F-15-E	YAI-CSM33-15-P-E			
		20 m	JZSP-C7M33F-20-E	JZSP-C7M34F-20-E	YAI-CSM33-20-P-E			
SGM7A-A5 to -C2  50 W to 150 W (200V)	Power cable for Servo Motors with Holding Brakes	30 m	JZSP-C7M33F-30-E	JZSP-C7M34F-30-E	YAI-CSM33-30-P-E	<p style="text-align: center;">N/A</p> 		
		40 m	JZSP-C7M33F-40-E	JZSP-C7M34F-40-E	YAI-CSM33-40-P-E			
		50 m	JZSP-C7M33F-50-E	JZSP-C7M34F-50-E	YAI-CSM33-50-P-E			
		SGM7A-02 to -06  200 W to 600 W (200V)	Cable installed away from load	3 m	JZSP-C7M13G-03-E		JZSP-C7M14G-03-E	
				5 m	JZSP-C7M13G-05-E		JZSP-C7M14G-05-E	
				10 m	JZSP-C7M13G-10-E		JZSP-C7M14G-10-E	
				15 m	JZSP-C7M13G-15-E		JZSP-C7M14G-15-E	
20 m	JZSP-C7M13G-20-E			JZSP-C7M14G-20-E				
30 m	JZSP-C7M13G-30-E			JZSP-C7M14G-30-E				
40 m	JZSP-C7M13G-40-E			JZSP-C7M14G-40-E				
SGM7A-08 and -10  750 W, 1.0 kW (200V)	Cable installed away from load	50 m	JZSP-C7M13G-50-E	JZSP-C7M14G-50-E				
		3 m	JZSP-C7M23G-03-E	JZSP-C7M24G-03-E				
		5 m	JZSP-C7M23G-05-E	JZSP-C7M24G-05-E				
		10 m	JZSP-C7M23G-10-E	JZSP-C7M24G-10-E				
		15 m	JZSP-C7M23G-15-E	JZSP-C7M24G-15-E				
		20 m	JZSP-C7M23G-20-E	JZSP-C7M24G-20-E				
		30 m	JZSP-C7M23G-30-E	JZSP-C7M24G-30-E				
SGM7A-08 and -10  750 W, 1.0 kW (200V)	Cable installed away from load	40 m	JZSP-C7M23G-40-E	JZSP-C7M24G-40-E				
		50 m	JZSP-C7M23G-50-E	JZSP-C7M24G-50-E				
		3 m	JZSP-C7M33G-03-E	JZSP-C7M34G-03-E				
		5 m	JZSP-C7M33G-05-E	JZSP-C7M34G-05-E				
		10 m	JZSP-C7M33G-10-E	JZSP-C7M34G-10-E				
		15 m	JZSP-C7M33G-15-E	JZSP-C7M34G-15-E				
		20 m	JZSP-C7M33G-20-E	JZSP-C7M34G-20-E				
SGM7A-08 and -10  750 W, 1.0 kW (200V)	Cable installed away from load	30 m	JZSP-C7M33G-30-E	JZSP-C7M34G-30-E				
		40 m	JZSP-C7M33G-40-E	JZSP-C7M34G-40-E				
		50 m	JZSP-C7M33G-50-E	JZSP-C7M34G-50-E				

\* Use Flexible Cables for moving parts of machines, such as robots.

## Rotary Servo Motors

### SGM7A

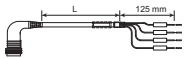
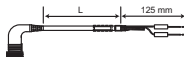
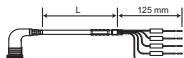
Servo Motor Model	Name	Length (L)	Order Number			Appearance	
			Standard Cable	Flexible Cable*	Flexible/Shielded		
SGM7A-15 to -25 1.5 to 2.5 kW (200V)	Power cable for Servo Motors	3 m	B1EV-03(A)-E	N/A	B1EP-03(A)-E		
		5 m	B1EV-05(A)-E	N/A	B1EP-05(A)-E		
		10 m	B1EV-10(A)-E	N/A	B1EP-10(A)-E		
		15 m	B1EV-15(A)-E	N/A	B1EP-15(A)-E		
		20 m	B1EV-20(A)-E	N/A	B1EP-20(A)-E		
SGM7A-30 3.0 kW (200V)	Cable installed toward load	3 m	B3EV-03(A)-E	N/A	B3EP-03(A)-E		
		5 m	B3EV-05(A)-E	N/A	B3EP-05(A)-E		
		10 m	B3EV-10(A)-E	N/A	B3EP-10(A)-E		
		15 m	B3EV-15(A)-E	N/A	B3EP-15(A)-E		
SGM7A-40 to -70 4.0 to 7.0 kW (200V)	Cable installed toward load	20 m	B3EV-20(A)-E	N/A	B3EP-20(A)-E		
		3 m	B4EV-03(A)-E	N/A	B4EP-03(A)-E		
		5 m	B4EV-05(A)-E	N/A	B4EP-05(A)-E		
		10 m	B4EV-10(A)-E	N/A	B4EP-10(A)-E		
SGM7A-15 to -50 1.5 to 5.0 kW (200V)	Brake cable for Servo Motors with Holding Brakes Cable installed toward load **	15 m	B4EV-15(A)-E	N/A	B4EP-15(A)-E		
		3 m	BBEV-03(A)-E	N/A	BBEP-03(A)-E		
		5 m	BBEV-05(A)-E	N/A	BBEP-05(A)-E		
		10 m	BBEV-10(A)-E	N/A	BBEP-10(A)-E		
		20 m	BBEV-20(A)-E	N/A	BBEP-20(A)-E		
SGM7A-70 7.0kW (200V)	Fan Cable (required)	3 m	BFEV-03(A)-E	N/A	N/A		
		5 m	BFEV-05(A)-E	N/A	N/A		
		10 m	BFEV-10(A)-E	N/A	N/A		
		15 m	BFEV-15(A)-E	N/A	N/A		
		20 m	BFEV-20(A)-E	N/A	N/A		

\* Use Flexible Cables for moving parts of machines, such as robots.

\*\* Note: Both a power cable and a separate brake cable are required for motors with holding brakes. Use brake cable shown along with the power cables designated for motors without holding brakes.



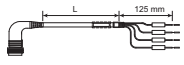
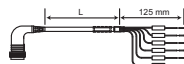

## Servo Motor Main Circuit Cables (400 V Models)

Servo Motor Model	Name	Length (L)	Order Number			Appearance
			Standard Cable	Flexible Cable*	Flexible/Shielded	
SGM7A-02 to -08 200W to 750 W (400V)	Power Cable with-out Brake. Cable installed toward load	3 m	N/A	N/A	JZSP-C7M143-03-E-G6	
		5 m	N/A	N/A	JZSP-C7M143-05-E-G6	
		10 m	N/A	N/A	JZSP-C7M143-10-E-G6	
		15 m	N/A	N/A	JZSP-C7M143-15-E-G6	
		20 m	N/A	N/A	JZSP-C7M143-20-E-G6	
SGM7A-10 1.0kW (400V)		3 m	N/A	N/A	JZSP-C7M144-03-E-G6	
		5 m	N/A	N/A	JZSP-C7M144-05-E-G6	
		10 m	N/A	N/A	JZSP-C7M144-10-E-G6	
		15 m	N/A	N/A	JZSP-C7M144-15-E-G6	
		20 m	N/A	N/A	JZSP-C7M144-20-E-G6	
SGM7A-02 to -08 200W to 750 W (400V)	Power Cable with Brake. Cable installed toward load	3 m	N/A	N/A	JZSP-C7M343-03-E-G6	
		5 m	N/A	N/A	JZSP-C7M343-05-E-G6	
		10 m	N/A	N/A	JZSP-C7M343-10-E-G6	
		15 m	N/A	N/A	JZSP-C7M343-15-E-G6	
		20 m	N/A	N/A	JZSP-C7M343-20-E-G6	
SGM7A-10 1.0kW (400V)		3 m	N/A	N/A	JZSP-C7M344-03-E-G6	
		5 m	N/A	N/A	JZSP-C7M344-05-E-G6	
		10 m	N/A	N/A	JZSP-C7M344-10-E-G6	
		15 m	N/A	N/A	JZSP-C7M344-15-E-G6	
		20 m	N/A	N/A	JZSP-C7M344-20-E-G6	

\* Use Flexible Cables for moving parts of machines, such as robots.

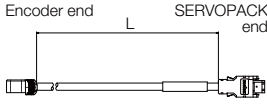
## Encoder Cables of 20 m or Less (200V Models)

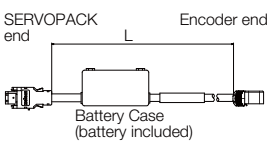
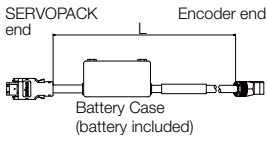
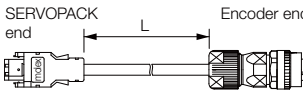
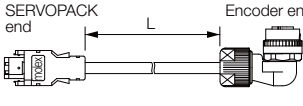
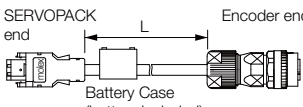
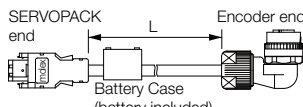
Servo Motor Model	Name	Length (L)	Order Number		Appearance	
			Standard Cable	Flexible Cable* <sup>1</sup>		
SGM7A-A5 to -10 50 W to 1.0 kW	For incremental encoder	3 m	JZSP-C7PI0D-03-E	JZSP-C7PI2D-03-E		
		5 m	JZSP-C7PI0D-05-E	JZSP-C7PI2D-05-E		
		10 m	JZSP-C7PI0D-10-E	JZSP-C7PI2D-10-E		
		15 m	JZSP-C7PI0D-15-E	JZSP-C7PI2D-15-E		
		20 m	JZSP-C7PI0D-20-E	JZSP-C7PI2D-20-E		
	Cable installed toward load	For incremental encoder	3 m	JZSP-C7PI0E-03-E	JZSP-C7PI2E-03-E	
			5 m	JZSP-C7PI0E-05-E	JZSP-C7PI2E-05-E	
			10 m	JZSP-C7PI0E-10-E	JZSP-C7PI2E-10-E	
			15 m	JZSP-C7PI0E-15-E	JZSP-C7PI2E-15-E	
			20 m	JZSP-C7PI0E-20-E	JZSP-C7PI2E-20-E	
	Cable installed away from load	For absolute encoder: With Battery Case* <sup>2</sup>	3 m	JZSP-C7PA0D-03-E	JZSP-C7PA2D-03-E	
			5 m	JZSP-C7PA0D-05-E	JZSP-C7PA2D-05-E	
			10 m	JZSP-C7PA0D-10-E	JZSP-C7PA2D-10-E	
			15 m	JZSP-C7PA0D-15-E	JZSP-C7PA2D-15-E	
			20 m	JZSP-C7PA0D-20-E	JZSP-C7PA2D-20-E	
	Cable installed toward load	For absolute encoder: With Battery Case* <sup>2</sup>	3 m	JZSP-C7PA0E-03-E	JZSP-C7PA2E-03-E	
			5 m	JZSP-C7PA0E-05-E	JZSP-C7PA2E-05-E	
			10 m	JZSP-C7PA0E-10-E	JZSP-C7PA2E-10-E	
			15 m	JZSP-C7PA0E-15-E	JZSP-C7PA2E-15-E	
			20 m	JZSP-C7PA0E-20-E	JZSP-C7PA2E-20-E	
SGM7A-15 to -70 1.5 kW to 7.0 kW	For incremental encoder	3 m	JZSP-CVP01-03-E	JZSP-CVP11-03-E		
		5 m	JZSP-CVP01-05-E	JZSP-CVP11-05-E		
		10 m	JZSP-CVP01-10-E	JZSP-CVP11-10-E		
		15 m	JZSP-CVP01-15-E	JZSP-CVP11-15-E		
		20 m	JZSP-CVP01-20-E	JZSP-CVP11-20-E		
		3 m	JZSP-CVP02-03-E	JZSP-CVP12-03-E		
		5 m	JZSP-CVP02-05-E	JZSP-CVP12-05-E		
		10 m	JZSP-CVP02-10-E	JZSP-CVP12-10-E		
	15 m	JZSP-CVP02-15-E	JZSP-CVP12-15-E			
	For absolute encoder: With Battery Case* <sup>2</sup>	Cable installed toward load	3 m	JZSP-CVP06-03-E	JZSP-CVP26-03-E	
			5 m	JZSP-CVP06-05-E	JZSP-CVP26-05-E	
			10 m	JZSP-CVP06-10-E	JZSP-CVP26-10-E	
			15 m	JZSP-CVP06-15-E	JZSP-CVP26-15-E	
		Cable installed away from load	3 m	JZSP-CVP07-03-E	JZSP-CVP27-03-E	
			5 m	JZSP-CVP07-05-E	JZSP-CVP27-05-E	
			10 m	JZSP-CVP07-10-E	JZSP-CVP27-10-E	
15 m			JZSP-CVP07-15-E	JZSP-CVP27-15-E		
20 m	JZSP-CVP07-20-E	JZSP-CVP27-20-E				

\*1. Use Flexible Cables for moving parts of machines, such as robots.

\*2. If a battery is connected to host controller, the Battery Case is not required. If so, use a cable for incremental encoders.

## Encoder Cables of 20 m or Less (400V Models)

Servo Motor Model	Name	Length (L)	Order Number		Appearance
			Standard Cable	Flexible Cable* <sup>1</sup>	
SGM7A-02 to -10 200 W to 1.0 kW	For incremental encoder	3 m	N/A	JZSP-C7PI2N-03-E-G6	
		5 m	N/A	JZSP-C7PI2N-05-E-G6	
		10 m	N/A	JZSP-C7PI2N-10-E-G6	
	Cable installed toward load	15 m	N/A	JZSP-C7PI2N-15-E-G6	
		20 m	N/A	JZSP-C7PI2N-20-E-G6	

## Relay Encoder Cable of 30 m to 50 m

Servo Motor Model	Name	Length (L)	Order Number	Appearance
SGM7A-A5 to -10 50 W to 1.0 kW	Encoder-end Cable (for incremental or absolute encoder) Cable installed toward load	0.3 m	JZSP-C7PRCD-E	
	Encoder-end Cable (for incremental or absolute encoder) Cable installed away from load	0.3 m	JZSP-C7PRCE-E	
	Cables with Connectors on Both Ends (for incremental or absolute encoder)	30 m	JZSP-UCMP00-30-E	
		40 m	JZSP-UCMP00-40-E	
		50 m	JZSP-UCMP00-50-E	
Cable with a Battery Case (Required when an absolute encoder is used.*)	0.3 m	JZSP-CSP12-E		
SGM7A-15 to -70 1.5 kW to 7.0 kW	Encoder-end Cable (for incremental or absolute encoder)	0.3 m	JZSP-CVP01-E	
			JZSP-CVP02-E	
	Cables with Connectors on Both Ends (for incremental or absolute encoder)	30 m	JZSP-UCMP00-30-E	
		40 m	JZSP-UCMP00-40-E	
		50 m	JZSP-UCMP00-50-E	
Cable with a Battery Case (Required when an absolute encoder is used.*)	0.3 m	JZSP-CSP12-E		

\* This Cable is not required if a battery is connected to the host controller.

---

## Connector Specifications

---

### ◆ SGM7A-15 to -50 without Holding Brakes

- Encoder Connector Specifications (24-bit Encoder)

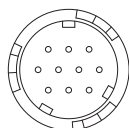

Receptacle: CM10-R10P-D  
Applicable plug: Not provided by Yaskawa.  
Plug: CM10-AP10S-□-D for Right-angle Plug  
CM10-SP10S-□-D for Straight Plug  
(□ depends on the applicable cable size.)  
Manufacturer: DDK Ltd.

- Servo Motor Connector Specifications

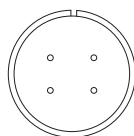

Manufacturer: DDK Ltd.

### ◆ SGM7A-70 without Holding Brakes

- Encoder Connector Specifications (24-bit Encoder)

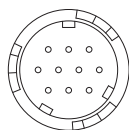

Receptacle: CM10-R10P-D  
Applicable plug: Not provided by Yaskawa.  
Plug: CM10-AP10S-□-D for Right-angle Plug  
CM10-SP10S-□-D for Straight Plug  
(□ depends on the applicable cable size.)  
Manufacturer: DDK Ltd.

- Servo Motor Connector Specifications

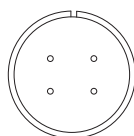

Manufacturer: DDK Ltd.

- Fan Connector Specifications

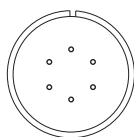

Receptacle: MS3102A14S-6P  
Applicable Plug  
Plug: MS3108B14S-6S  
Cable Clamp: MS3057-6A

Note: The Servo Motor Connector (receptacle) is RoHS compliant.  
Contact the connector manufacturer for RoHS-compliant cable-side connectors (not provided by Yaskawa).

◆ SGM7A-15 to -50 with Holding Brakes

- Encoder Connector Specifications (24-bit Encoder)

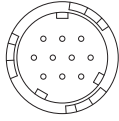

Receptacle: CM10-R10P-D  
Applicable plug: Not provided by Yaskawa.  
Plug: CM10-AP10S-□-D for Right-angle Plug  
CM10-SP10S-□-D for Straight Plug  
(□ depends on the applicable cable size.)  
Manufacturer: DDK Ltd.

- Servo Motor Connector Specifications

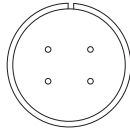

Manufacturer: DDK Ltd.

- Brake Connector Specifications

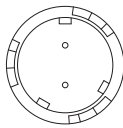

Receptacle: CM10-R2P-D  
Applicable plug: Not provided by Yaskawa.  
Plug: CM10-AP2S-□-D for Right-angle Plug  
CM10-SP2S-□-D for Straight Plug  
(□ depends on the applicable cable size.)  
Manufacturer: DDK Ltd.

# SGM7P

## SGM7P Servo Motors (without Gear Box)

### Model Designations

SGM7P - 01 A 7 J 6 1 □

Σ-7 Series  
Servo Motors:  
SGM7P

1st+2nd  
digits

3rd  
digit

4th  
digit

5th  
digit

6th  
digit

7th  
digit

8th  
digit

**1st+2nd digits** Rated Output

Code	Specification
01	100 W
02	200 W
04	400 W
08	750 W
15	1.5 kW

**3rd digit** Power Supply Voltage

Code	Specification
A	200 VAC

**4th digit** Serial Encoder

Code	Specification
7	24-bit absolute
F	24-bit incremental

**5th digit** Design Revision Order

Code	Specification
J	IP67 (01, 02, and 04 Models)
E	IP67 (08 and 15 Models)

**6th digit** Shaft End

Code	Specification
2	Straight without key
6	Straight with key and tap

**7th digit** Options

Code	Specification
1	Without options
C	With holding brake (24 VDC)
E	With oil seal and holding brake (24 VDC)
S	With oil seal

**8th digit** Connector Specification

Code	Specification
Blank	Standard (01, 02, 04 Models)
D	Interconnectron (08, 15 Models)

■ Non Stock Items

# SGM7P

## SGM7P Gear Motors

The SGM7P gear motor product family pairs SGM7P servo motors with high precision, low backlash inline planetary gear heads resulting in a portfolio of rotary actuators fit for a wide range of applications. The family of gear motors has been thoroughly tested and adheres to the high levels of quality and performance expected from Yaskawa.

The high precision gear heads offer a variety of application advantages:

- ① **Quiet operation** – helical cut gears contribute toward reduced vibration and noise
- ② **High precision** – a standard backlash of 5 arc-min make this gear head ideal for the most accurate applications
- ③ **High rigidity and torque capacity** – achieved with a design which incorporates uncaged needle roller bearings
- ④ **Optimized adapter bushing** – minimizes inertia allowing for more output torque to be realized
- ⑤ **No leakage through the seal** – high viscosity, anti-separation grease does not liquefy and does not migrate away from the gears
- **Maintenance-free** – no need to replace the grease for the life of the unit. The reducer can be positioned in any orientation

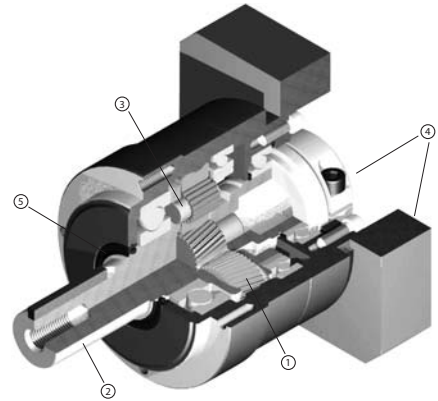

## Model Designations

S7P 01 A C - VL 050 - 05

Σ-7 Series  
Gear Motors:  
SGM7P

1st+2nd digits

3rd digit

4th digit

5th digit

6th digit

7th digit

1st+2nd digits Rated Output

Code	Specification
01	100 W
02	200 W
04	400 W
08	750 W
15	1.5 kW

3rd digit Power Supply Voltage

Code	Specification
A	200 VAC

4th digit Brake Option

Code	Specification
Blank	No brake
C	24 V Brake

5th digit Gear box backlash

Code	Specification
VL	5 arc-min backlash

6th digit Gear head frame size

Code	Specification
050	50 mm
070	70 mm
090	90 mm
120	120 mm

7th digit Gear Ratio

Code	Specification
03	3:1 Ratio
05	5:1 Ratio
10	10:1 Ratio
25	25:1 Ratio
50	50:1 Ratio

## Specifications and Ratings

### Specifications

Voltage		200 V				
Model SGM7P-		01A	02A	04A	08A	15A
Time Rating		Continuous				
Thermal Class		UL: B, CE: B				
Insulation Resistance		500 VDC, 10 MΩmin.				
Withstand Voltage		1,500 VAC for 1 minute				
Excitation		Permanent magnet				
Mounting		Flange-mounted				
Drive Method		Direct drive				
Rotation Direction		Counterclockwise (CCW) for forward reference when viewed from the load side				
Vibration Class <sup>*1</sup>		V15				
Environmental Conditions	Surrounding Air Temperature	0°C to 40°C (With derating, usage is possible between 40°C and 60°C.) <sup>*4</sup>				
	Surrounding Air Humidity	20% to 80% relative humidity (with no condensation)				
	Installation Site	<ul style="list-style-type: none"> <li>• Must be indoors and free of corrosive and explosive gases.</li> <li>• Must be well-ventilated and free of dust and moisture.</li> <li>• Must facilitate inspection and cleaning.</li> <li>• Must have an altitude of 1,000 m or less. (With derating, usage is possible between 1,000 m and 2,000 m.)<sup>*5</sup></li> <li>• Must be free of strong magnetic fields.</li> </ul>				
	Storage Environment	Store the Servo Motor in the following environment if you store it with the power cable disconnected. Storage Temperature: -20°C to 60°C (with no freezing) Storage Humidity: 20% to 80% relative humidity (with no condensation)				
Shock Resistance <sup>*2</sup>	Impact Acceleration Rate at Flange	490 m/s <sup>2</sup>				
	Number of Impacts	2 times				
Vibration Resistance <sup>*3</sup>	Vibration Acceleration Rate at Flange	49 m/s <sup>2</sup>				
Applicable SERVOPACKs	SGD7S-	R90A	2R8A	5R5A	120A	
	SGD7W-	1R6A <sup>*6</sup> , 2R8A <sup>*6</sup>	2R8A, 5R5A <sup>*6</sup> , 7R6A <sup>*6</sup>	5R5A, 7R6A	-	

\*1. A vibration class of V15 indicates a vibration amplitude of 15 μm maximum on the Servo Motor without a load at the rated motor speed.

\*2. The shock resistance for shock in the vertical direction when the Servo Motor is mounted with the shaft in a horizontal position is given in the above table.

\*3. The vertical, side-to-side, and front-to-back vibration resistance for vibration in three directions when the Servo Motor is mounted with the shaft in a horizontal position is given in the above table. The strength of the vibration that the Servo Motor can withstand depends on the application. Always check the vibration acceleration rate that is applied to the Servo Motor with the actual equipment.

\*4. If the surrounding air temperature will exceed 40°C, refer to the following section.

 **Applications Where the Surrounding Air Temperature of the Servo Motor Exceeds 40°C (page 98)**

\*5. If the altitude will exceed 1,000 m, refer to the following section.

 **Applications Where the Altitude of the Servo Motor Exceeds 1,000 m (page 99)**

\*6. If you use the Servo Motor together with a S-7W SERVOPACK, the control gain may not increase as much as with a S-7S SERVOPACK and other performances may be lower than those achieved with a S-7S SERVOPACK.

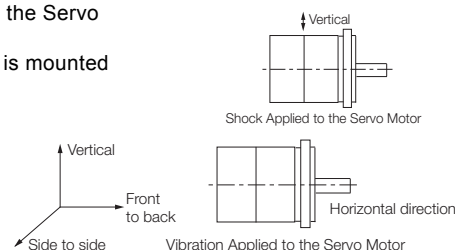



## Ratings of Servo Motors

Voltage		200 V					
Model SGM7P-		01A	02A	04A	08A	15A	
Rated Output <sup>*1</sup>	W	100	200	400	750	1500	
Rated Torque <sup>*1, *2</sup>	N•m	0.318	0.637	1.27	2.39	4.77	
Instantaneous Maximum Torque <sup>*1</sup>	N•m	0.955	1.91	3.82	7.16	14.3	
Rated Current <sup>*1</sup>	Arms	0.86	2.0	2.6	5.4	9.2	
Instantaneous Maximum Current <sup>*1</sup>	Arms	2.8	6.4	8.4	16.5	28.0	
Rated Motor Speed <sup>*1</sup>	min <sup>-1</sup>	3000					
Maximum Motor Speed <sup>*1</sup>	min <sup>-1</sup>	6000					
Torque Constant	N•m/Arms	0.401	0.355	0.524	0.476	0.559	
Motor Moment of Inertia	×10 <sup>-4</sup> kg•m <sup>2</sup>	0.0592 (0.0892)	0.263 (0.415)	0.409 (0.561)	2.10 (2.98)	4.02 (4.90)	
Rated Power Rate <sup>*1</sup>	kW/s	17.1 (11.3)	15.4 (9.7)	39.6 (28.8)	27.2 (19.1)	56.6 (46.4)	
Rated Angular Acceleration Rate <sup>*1</sup>	rad/s <sup>2</sup>	53700 (35600)	24200 (15300)	31100 (22600)	11400 (8020)	11900 (9730)	
Derating Rate for Servo Motor with Oil Seal	%	90		95			
Heat Sink Size	mm	250 × 250 × 6			300 × 300 × 12		
Protective Structure <sup>*3</sup>		Totally enclosed, self-cooled, IP65					
Holding Brake Specifications <sup>*4</sup>	Rated Voltage	V	24 VDC ±10%				
	Capacity	W	6	7.4		7.5	
	Holding Torque	N•m	0.318	0.637	1.27	2.39	4.77
	Coil Resistance	Ω(at 20°C)	96	84.5		76.8	
	Rated Current	A (at 20°C)	0.25	0.31		0.31	
	Time Required to Release Brake	ms	80				
	Time Required to Brake	ms	100				
Allowable Load Moment of Inertia (Motor Moment of Inertia Ratio)		25 times	15 times	10 times	5 times		
	With External Regenerative Resistor and Dynamic Brake Resistor						
Allowable Shaft Loads <sup>*5</sup>	LF	mm	20	25		35	
	Allowable Radial Load	N	78	245		392	490
	Allowable Thrust Load	N	49	68		147	

Note: The values in parentheses are for Servo Motors with Holding Brakes.

\*1. These values are for operation in combination with a SERVOPACK when the temperature of the armature winding is 100°C. The values for other items are at 20°C. These are typical values.

\*2. The rated torques are the continuous allowable torque values at a surrounding air temperature of 40°C with an aluminum heat sink of the dimensions given in the table.

\*3. This does not apply to the shaft opening. Protective structure specifications apply only when the special cable is used.

\*4. Observe the following precautions if you use a Servo Motor with a Holding Brake.

- The holding brake cannot be used to stop the Servo Motor.
- The time required to release the brake and the time required to brake depend on which discharge circuit is used. Confirm that the operation delay time is appropriate for the actual equipment.

\*5. The 24-VDC power supply is not provided by Yaskawa. The allowable shaft loads are illustrated in the following figure. Design the mechanical system so that the thrust and radial loads applied to the Servo Motor shaft end during operation do not exceed the values given in the table.

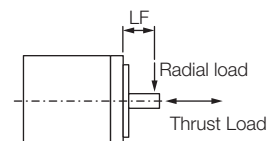

## Torque-Motor Speed Characteristics

**A** : Continuous duty zone      — (solid lines): With three-phase 200-V or single-phase 230-V input  
**B** : Intermittent duty zone      - - - - (dotted lines): With single-phase 200-V input

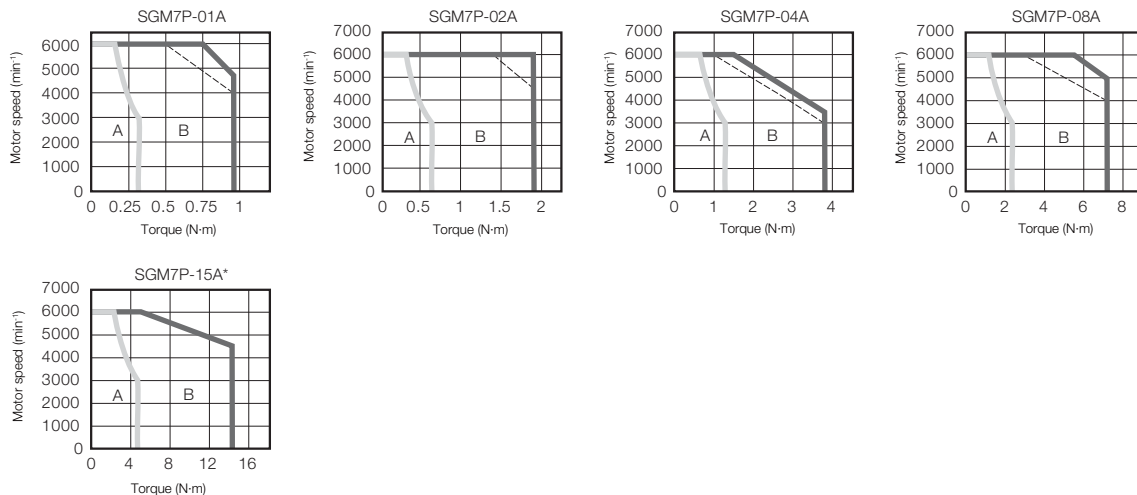

\* You cannot use the SGM7P-15A Servo Motor together with a SERVOPACK with a single-phase power supply input.

Note: 1. These values are for operation in combination with a SERVOPACK when the temperature of the armature winding is 100°C. These are typical values.

2. The characteristics in the intermittent duty zone depend on the power supply voltage.
3. If the effective torque is within the allowable range for the rated torque, the Servo Motor can be used within the intermittent duty zone.
4. If you use a Servo Motor Main Circuit Cable that exceeds 20 m, the intermittent duty zone in the torque-motor speed characteristics will become smaller because the voltage drop increases.

## Ratings of Gear Motors (200 V Models)

Gear Motor Model Number	Base Servo Motor Model (SGM7P-)	Gear Ratio	Gearing Efficiency <sup>*1</sup>	Rated Speed (RPM)	Max Speed (RPM)	Rated Torque (Nm) <sup>*2</sup>	Peak Torque (Nm) <sup>*2</sup>	Motor Inertia (x10 <sup>-4</sup> kg-m <sup>2</sup> )	Gear-head Inertia (x10 <sup>-4</sup> kg-m <sup>2</sup> )	Allowable Radial Load (N)	Allowable Axial Load (N)	Backlash (arc-min)	Protection Class	
S7P01A□ -VL050-03	01A7J6□	3:1	95	1000	2000	0.906	2.72	0.0592 (0.0892)	0.053	710	640	5	IP65	
S7P01A□ -VL050-05		5:1		600	1200	1.51	4.54		0.036					
S7P01A□ -VL050-10		10:1		300	600	3.02	9.07		0.030					
S7P01A□ -VL050-25		25:1	120	240	7.16	18.0 <sup>*3</sup>	0.030							
S7P01A□ -VL070-50		50:1	90	60	120	14.3	43.0		0.049					1200
S7P02A□ -VL070-03	02A7J6□	3:1	95	1000	2000	1.82	5.44	0.263 (0.415)	0.220	1200	1100	5		
S7P02A□ -VL070-05		5:1		600	1200	3.03	9.07		0.160					
S7P02A□ -VL070-10		10:1		300	600	6.05	18.1		0.140					
S7P02A□ -VL070-25		25:1	120	240	14.3	43.0	0.130							
S7P02A□ -VL070-50		50:1	90	60	120	28.7	50.0 <sup>*3</sup>		0.130					
S7P04A□ -VL070-03	04A7J6□	3:1	95	1000	2000	3.62	10.9	0.409 (0.561)	0.220	1200	1100			5
S7P04A□ -VL070-05		5:1		600	1200	6.03	18.1		0.160					
S7P04A□ -VL070-10		10:1		300	600	12.1	36.3		0.140					
S7P04A□ -VL070-25		25:1	120	240	28.6	50.0 <sup>*3</sup>	0.130							
S7P04A□ -VL090-50		50:1	90	60	120	57.2	125 <sup>*3</sup>		0.250				2400	
S7P08A□ -VL090-03	08A7E6□	3:1	95	1000	2000	6.81	20.4	2.100 (2.980)	1.200	2400	2200		5	
S7P08A□ -VL090-05		5:1		600	1200	11.4	34.0		0.860					
S7P08A□ -VL090-10		10:1		300	600	22.7	68.0		0.750					
S7P08A□ -VL090-25		25:1	120	240	53.8	125 <sup>*3</sup>	0.710							
S7P08A□ -VL120-50		50:1	90	60	120	108	322		0.730			4300		
S7P15A□ -VL090-03	10A7E6□	3:1	95	1000	2000	13.6	40.8	4.020 (4.900)	1.200	2400	2200	5		
S7P15A□ -VL090-05		5:1		600	1200	22.7	67.9		0.860					
S7P15A□ -VL090-10		10:1		300	600	45.3	80 <sup>*3</sup>		0.750					
S7P15A□ -VL120-25		25:1	120	240	107	322	0.820							
S7P15A□ -VL120-50		50:1	90	60	120	180 <sup>*3</sup>	330 <sup>*3</sup>		0.730					4300

Note: The values in parentheses are for Servo Motors with Holding Brakes (indicated by value of □ in model numbers).

\*1. The gear efficiency depends on operating conditions such as the output torque, motor speed, and temperature.

\*2. The gear motor output torque is expressed by the following formula: Output Torque = (Servo Motor Output Torque) x (Gearing Ratio) x (Gearing Efficiency). The values in the table are typical values for the rated torque, rated motor speed, and a surrounding air temperature of 25°C. They are reference values only.

\*3. The output torque of the gear motor is limited by the mechanical limit of the gear head. Operation above this limit could result in premature failure of the gear motor.



**Important** During operation of the gear motor, losses due to inefficiencies of the gearing mechanism are generated. The losses vary as the conditions for gear motor torque and speed change. Temperature rise can vary based on the mechanical inefficiencies and the heat dissipation conditions. For heat dissipation conditions, check the gear and motor temperatures with the actual equipment. If operating temperatures are too high, implement the following measures.

- Decrease the load ratio.
- Change the heat dissipation conditions.
- Use forced-air cooling for the motor with a cooling fan or other means.

## Servo Motor Overload Protection Characteristics

The overload detection level is set for hot start conditions with a Servo Motor surrounding air temperature of 40°C.

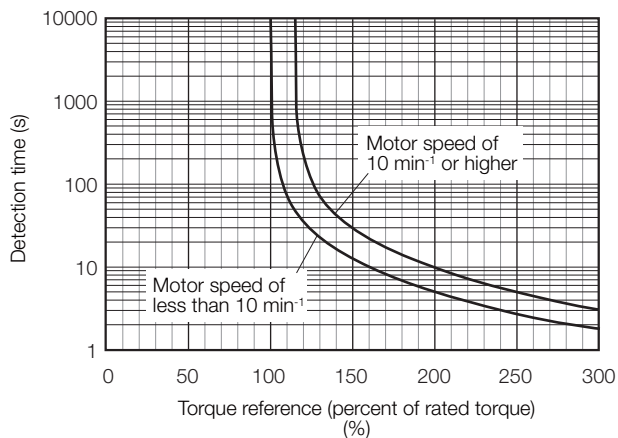

Note: The above overload protection characteristics do not mean that you can perform continuous duty operation with an output of 100% or higher. Use the Servo Motor so that the effective torque remains within the continuous duty zone given in *Torque-Motor Speed Characteristics* (page 94).

## Allowable Load Moment of Inertia Scaling Factor for SERVOPACKs without Built-in Regenerative Resistors

The following graphs show the allowable load moment of inertia scaling factor of the motor speed for SERVOPACKs\* without built-in regenerative resistors when an External Regenerative Resistor is not connected.

If the Servo Motor exceeds the allowable load moment of inertia, an overvoltage alarm may occur in the SERVOPACK.

These graphs provide reference data for deceleration at the rated torque or higher with a 200-VAC power supply input.

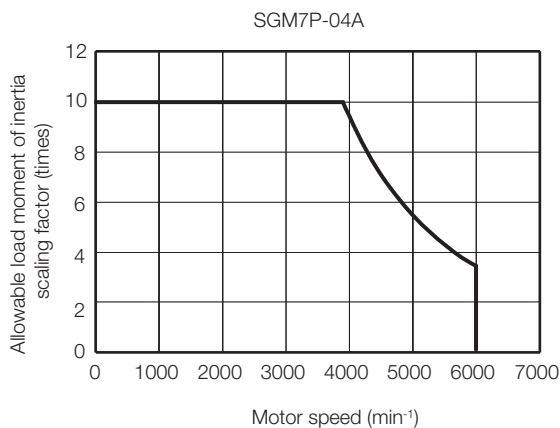
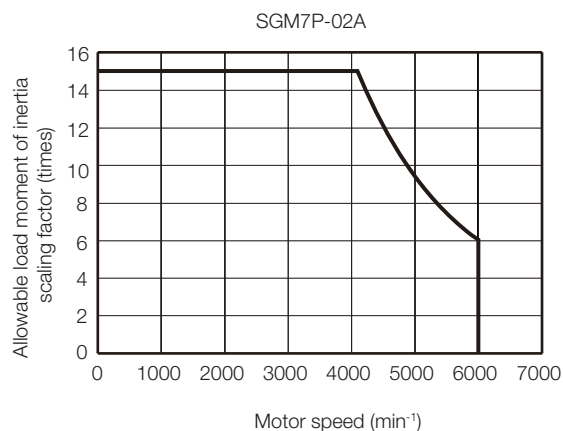
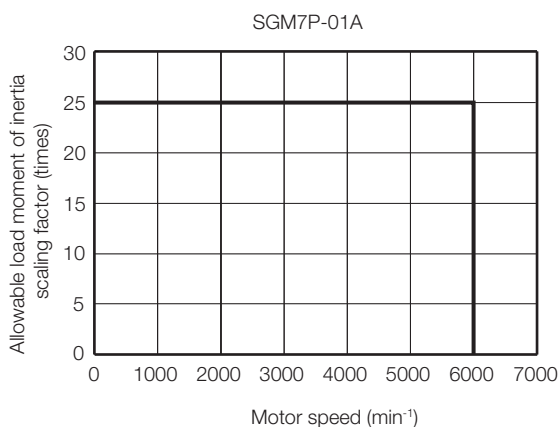

\* Applicable SERVOPACK models: SGD7S-R70A, -R90A, -1R6A, or -2R8A

## Servo Motor Heat Dissipation Conditions

The Servo Motor ratings are the continuous allowable values at a surrounding air temperature of 40°C when a heat sink is installed on the Servo Motor. If the Servo Motor is mounted on a small device component, the Servo Motor temperature may rise considerably because the surface for heat dissipation becomes smaller. Refer to the following graphs for the relation between the heat sink size and derating rate.

When using Servo Motors with derating, change the detection timing of overload warnings and overload alarms by referring to the motor overload detection level described in the following manual.

📖 *Σ-7-Series AC Servo Drive Rotary Servo Motor Product Manual* (Manual No.: SIEP S800001 36)

Note: The derating rates are applicable only when the average motor speed is less than or equal to the rated motor speed. If the average motor speed exceeds the rated motor speed, consult with your Yaskawa representative.



Important

The actual temperature rise depends on how the heat sink (i.e., the Servo Motor mounting section) is attached to the installation surface, what material is used for the Servo Motor mounting section, and the motor speed. Always check the Servo Motor temperature with the actual equipment.

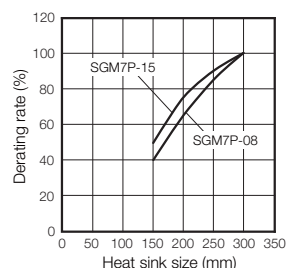
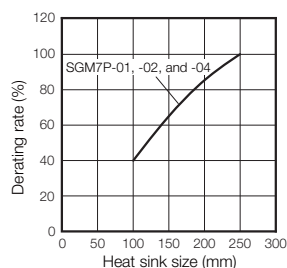

## Applications Where the Surrounding Air Temperature of the Servo Motor Exceeds 40°C

The Servo Motor ratings are the continuous allowable values at a surrounding air temperature of 40°C. If you use a Servo Motor at a surrounding air temperature that exceeds 40°C (60°C max.), apply a suitable derating rate from the following graphs.

When using Servo Motors with derating, change the detection timing of overload warnings and overload alarms by referring to the motor overload detection level described in the following manual.

📖 *Σ-7-Series AC Servo Drive Rotary Servo Motor Product Manual* (Manual No.: SIEP S800001 36)

Note: 1. Use the combination of the SERVOPACK and Servo Motor so that the derating conditions are satisfied for both the SERVOPACK and Servo Motor.

2. The derating rates are applicable only when the average motor speed is less than or equal to the rated motor speed. If the average motor speed exceeds the rated motor speed, consult with your Yaskawa representative.

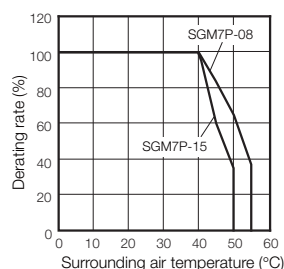
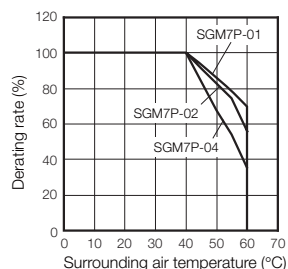

## Applications Where the Altitude of the Servo Motor Exceeds 1,000 m

The Servo Motor ratings are the continuous allowable values at an altitude of 1,000 m or less. If you use a Servo Motor at an altitude that exceeds 1,000 m (2,000 m max.), the heat dissipation effect of the air is reduced. Apply the appropriate derating rate from the following graphs.

When using Servo Motors with derating, change the detection timing of overload warnings and overload alarms by referring to the motor overload detection level described in the following manual.

📖 *Σ-7-Series AC Servo Drive Rotary Servo Motor Product Manual* (Manual No.: SIEP S80001 36)

Note: 1. Use the combination of the SERVOPACK and Servo Motor so that the derating conditions are satisfied for both the SERVOPACK and Servo Motor.

2. The derating rates are applicable only when the average motor speed is less than or equal to the rated motor speed. If the average motor speed exceeds the rated motor speed, consult with your Yaskawa representative.

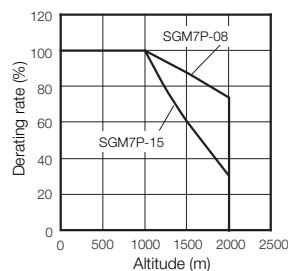
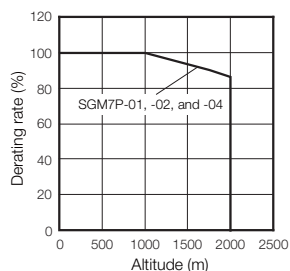

## External Dimensions

### ◆ SGM7P-01, -02, and -04

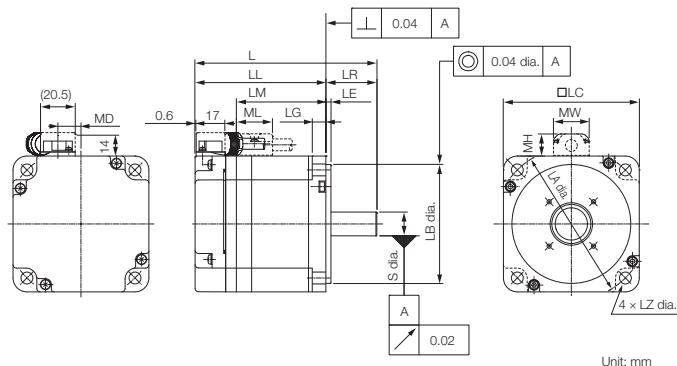

Model SGM7P-	L	LL	LM	Flange Dimensions							S
				LR	LE	LG	LC	LA	LB	LZ	
01A□A2□	85 (115)	60 (90)	36	25	3	6	60	70	50 <sup>0</sup> <sub>-0.025</sub>	5.5	8 <sup>0</sup> <sub>-0.009</sub>
02A□A2□	97 (128.5)	67 (98.5)	43	30	3	8	80	90	70 <sup>0</sup> <sub>-0.030</sub>	7	14 <sup>0</sup> <sub>-0.011</sub>
04A□A2□	107 (138.5)	77 (108.5)	53	30	3	8	80	90	70 <sup>0</sup> <sub>-0.030</sub>	7	14 <sup>0</sup> <sub>-0.011</sub>

Model SGM7P-	MD	MW	MH	ML	Approx. Mass [kg]
01A□A2□	8.5	19	12	20	0.5 (0.7)
02A□A2□	13.6	21	13	21	1.1 (1.6)
04A□A2□	13.6	21	13	21	1.4 (1.9)

Note: 1. The values in parentheses are for Servo Motors with Holding Brakes.

2. Refer to the following section for detailed shaft end specifications.

Gearmotor Models: 100W to 1.5kW (S7P01, S7P02, S7P04, S7P08, S7P15) (page 102)

### ■ Specifications of Options

#### • Oil Seal

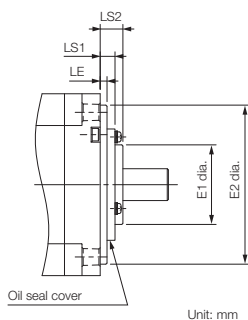

Model SGM7P-	Dimensions with Oil Seal				
	E1	E2	LS1	LS2	LE
01A□A2□	22	39	4	7.5	1.5
02A□A2□	35	49	6.5	10	2.5
04A□A2□					



◆ SGM7P-08 and -15

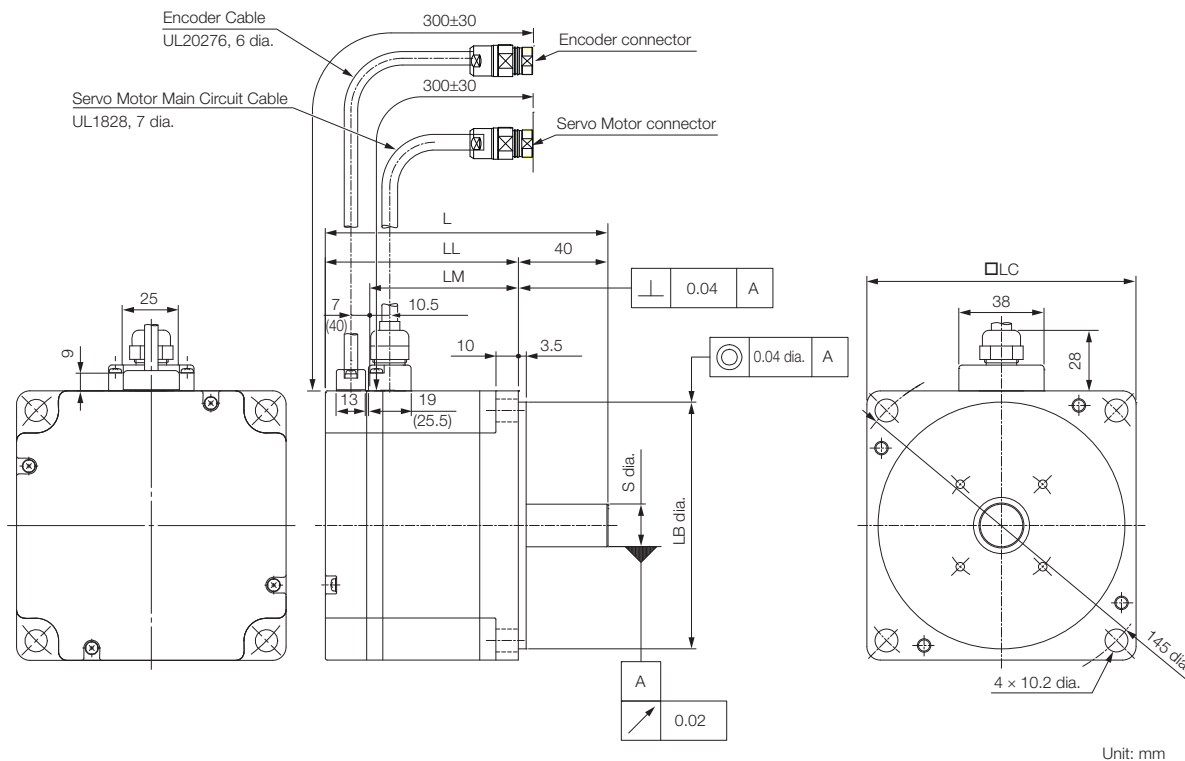

Model SGM7P-	L	LL	LM	LB	LC	S	Approx. Mass [kg]
08A□A2□	126.5 (160)	86.5 (120)	67.6	110 <sup>0</sup> <sub>-0.035</sub>	120	19 <sup>0</sup> <sub>-0.013</sub>	4.2 (5.7)
15A□A2□	154.5 (187.5)	114.5 (147.5)	95.6	110 <sup>0</sup> <sub>-0.035</sub>	120	19 <sup>0</sup> <sub>-0.013</sub>	6.6 (8.1)

Note: 1. The values in parentheses are for Servo Motors with Holding Brakes.

2. Refer to the following section for detailed shaft end specifications.

☞ Gearmotor Models: 100W to 1.5kW (S7P01, S7P02, S7P04, S7P08, S7P15) (page 102)

■ Specifications of Options

• Oil Seal

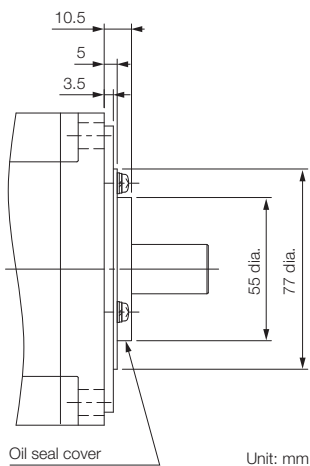

◆ Gearmotor Models: 100W to 1.5kW (S7P01, S7P02, S7P04, S7P08, S7P15)

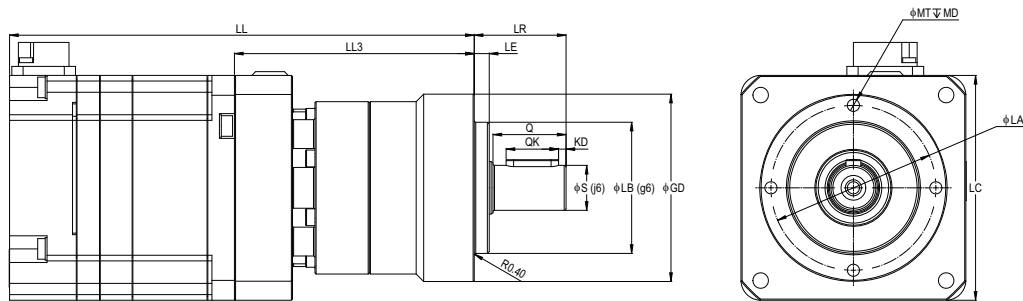

Shaft Detail (VL050 Models Only)

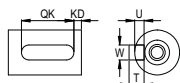

Shaft Detail (All Other Models)

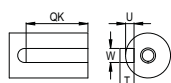

Model S7P	LL	LL3	LR	LE	φS	φLB	φGD	LC	φLA	φMT	MD	Q	QK	KD	W	U	T	
100 W Models																		
200 V	01A□ -VL050-03	124 (154)	64	24.5	4	12	35	50	60	44	M4	8	19.5	14	2	4	2.5	4
	01A□ -VL050-05																	
	01A□ -VL050-10																	
	01A□ -VL050-25	140.5 (170.5)	80.5															
	01A□ -VL070-50	155 (185)	95	36	5	16	52	70	62	M5	10	28	22	0	5	3	5	
200 W Models																		
200 V	02A□ -VL070-03	146 (177.5)	79	35	5	16	52	70	80	62	M5	10	28	22	0	5	3	5
	02A□ -VL070-05																	
	02A□ -VL050-10																	
	02A□ -VL070-25	167 (198.5)	100															
	02A□ -VL070-50	167 (198.5)	100	35	5	16	52	70	80	62	M5	10	28	22	0	5	3	5
400 W Models																		
200 V	04A□ -VL070-03	156 (187.5)	79	36	5	16	52	70	80	62	M5	10	28	22	0	5	3	5
	04A□ -VL070-05																	
	04A□ -VL070-10																	
	04A□ -VL070-25	177 (208.5)	100															
	04A□ -VL090-50	196 (227.5)	119	46	7	22	68	90	80	M6	12	36	28	0	6	3.5	6	
750 W Models																		
200 V	08A□ -VL090-03	193.5 (227)	107	46	7	22	68	90	130	80	M6	12	36	28	0	6	3.5	6
	08A□ -VL090-05																	
	08A□ -VL090-10																	
	08A□ -VL090-25	215.5 (249)	129															
	08A□ -VL120-50	231 (264.5)	144.5	70	9	32	90	120	108	M8	16	58	45	0	10	5	8	
1.5 kW Models																		
200 V	15A□ -VL090-03	221.5 (254.5)	107	46	7	22	68	90	130	80	M6	12	36	28	0	6	3.5	6
	15A□ -VL090-05																	
	15A□ -VL090-10																	
	15A□ -VL120-25	259 (292)	144.5	70	9	32	90	120	108	M8	16	58	45	0	10	5	8	
	15A□ -VL120-50	259 (292)	144.5	70	9	32	90	120	108	M8	16	58	45	0	10	5	8	

Note: The values in parentheses are for Servo Motors with Holding Brakes.

## Shaft End Specifications

### ◆ SGM7P-□□□□□□□□

Code	Specification
2	Straight without key
6	Straight with key and tap for one location (Key slot is JIS B1301-1996 fastening type.)

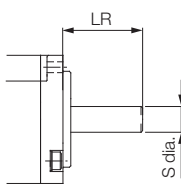
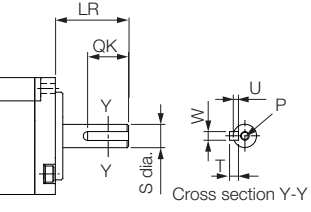
Shaft End Details	Servo Motor Model SGM7P-				
	01	02	04	08	15
<b>Code: 2 (Straight without Key)</b>					
	LR	25	30	40	
	S	$8^{0}_{-0.009}$	$14^{0}_{-0.011}$	$19^{0}_{-0.013}$	
<b>Code: 6 (Straight with Key and Tap)</b>					
	LR	25	30	40	
	QK	14	14	22	
	S	$8^{0}_{-0.009}$	$14^{0}_{-0.011}$	$19^{0}_{-0.013}$	
	W	3	5	6	
	T	3	5	6	
	U	1.8	3	3.5	
	P	M3 × 6L	M5 × 8L	M6 × 10L	

## Selecting Cables

### ◆ Cable Configurations

The cables shown below are required to connect a Servo Motor to a SERVOPACK.

Encoder Cable of 20 m or Less

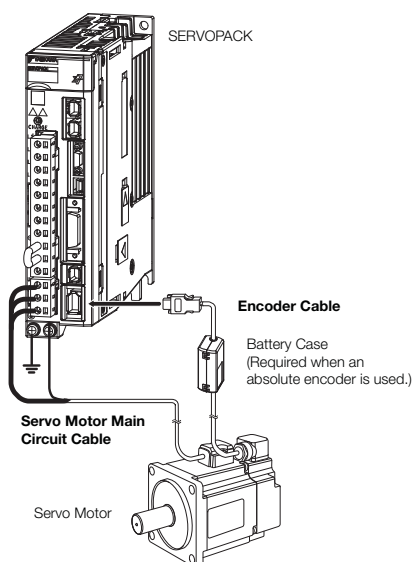

Encoder Cable of 30 m to 50 m (Relay Cable)

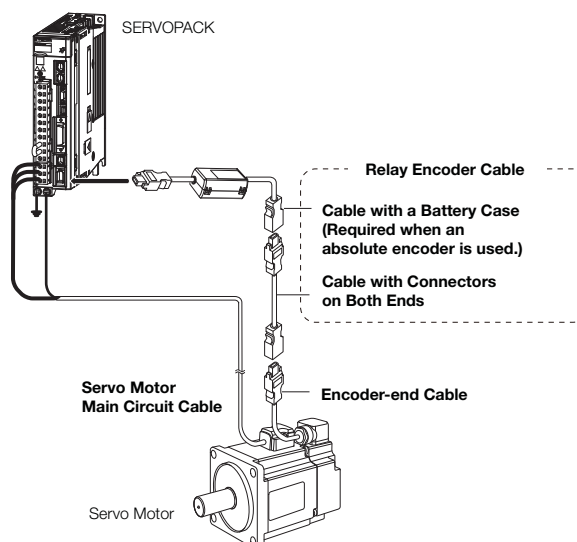

For SGM7P-08 or -15  
(750 W or 1.5 kW) Servo Motor

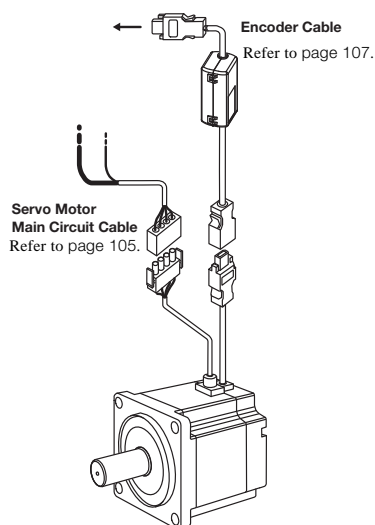

For SGM7P-08 or -15  
(750 W or 1.5 kW) Servo Motor

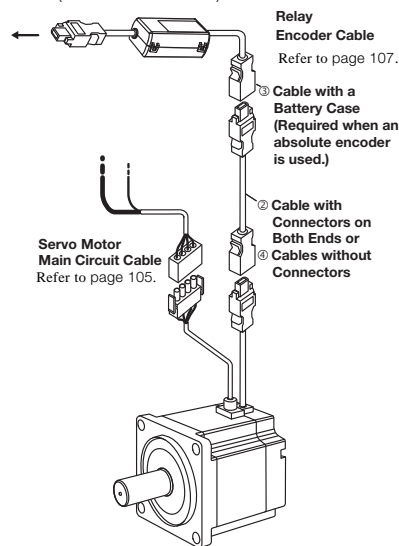

Note: 1. If the cable length exceeds 20 m, be sure to use a Relay Encoder Cable.

2. If you use a Servo Motor Main Circuit Cable that exceeds 20 m, the intermittent duty zone in the torque-motor speed characteristics will become smaller because the voltage drop increases.

3. Refer to the following manual for the following information.

- Cable dimensional drawings and cable connection specifications
- Order numbers and specifications of individual connectors for cables
- Order numbers and specifications for wiring materials

📖  $\Sigma$ -7-Series AC Servo Drive Peripheral Device Selection Manual (Manual No.: SIEP S800001 32)

## Servo Motor Main Circuit Cables

Servo Motor Model	Name	Length (L)	Order Number			Appearance
			Standard Cable	Flexible Cable*	Flexible and Shielded	
SGM7P-01 100 W	For Servo Motors without Holding Brakes	3 m	JZSP-CSM01-03-E	JZSP-CSM21-03-E	YAI-CSM21-03-P-E	
		5 m	JZSP-CSM01-05-E	JZSP-CSM21-05-E	YAI-CSM21-05-P-E	
		10 m	JZSP-CSM01-10-E	JZSP-CSM21-10-E	YAI-CSM21-10-P-E	
		15 m	JZSP-CSM01-15-E	JZSP-CSM21-15-E	YAI-CSM21-15-P-E	
		20 m	JZSP-CSM01-20-E	JZSP-CSM21-20-E	YAI-CSM21-20-P-E	
		30 m	JZSP-CSM01-30-E	JZSP-CSM21-30-E	YAI-CSM21-30-P-E	
		40 m	JZSP-CSM01-40-E	JZSP-CSM21-40-E	YAI-CSM21-40-P-E	
50 m		JZSP-CSM01-50-E	JZSP-CSM21-50-E	YAI-CSM21-50-P-E		
SGM7P-02 and -04 200 W, 400 W		3 m	JZSP-CSM02-03-E	JZSP-CSM22-03-E	YAI-CSM22-03-P-E	
		5 m	JZSP-CSM02-05-E	JZSP-CSM22-05-E	YAI-CSM22-05-P-E	
		10 m	JZSP-CSM02-10-E	JZSP-CSM22-10-E	YAI-CSM22-10-P-E	
		15 m	JZSP-CSM02-15-E	JZSP-CSM22-15-E	YAI-CSM22-15-P-E	
		20 m	JZSP-CSM02-20-E	JZSP-CSM22-20-E	YAI-CSM22-20-P-E	
		30 m	JZSP-CSM02-30-E	JZSP-CSM22-30-E	YAI-CSM22-30-P-E	
SGM7P-08 750 W		3 m	N/A	N/A	B4ICE-03(A)	
		5 m	N/A	N/A	B4ICE-05(A)	
		10 m	N/A	N/A	B4ICE-10(A)	
		15 m	N/A	N/A	B4ICE-15(A)	
		20 m	N/A	N/A	B4ICE-20(A)	
		30 m	N/A	N/A	B4ICE-30(A)	
		40 m	N/A	N/A	B4ICE-40(A)	
SGM7P-15 1.5 kW		3 m	N/A	N/A	B5ICE-03(A)	
		5 m	N/A	N/A	B5ICE-05(A)	
		10 m	N/A	N/A	B5ICE-10(A)	
		15 m	N/A	N/A	B5ICE-15(A)	
		20 m	N/A	N/A	B5ICE-20(A)	
		30 m	N/A	N/A	B5ICE-30(A)	
		40 m	N/A	N/A	B5ICE-40(A)	
50 m	N/A	N/A	B5ICE-50(A)			

\* Use Flexible Cables for moving parts of machines, such as robots.

## Rotary Servo Motors

### SGM7P

Servo Motor Model	Name	Length (L)	Order Number			Appearance
			Standard Cable	Flexible Cable*	Flexible and Shielded	
SGM7P-01 100 W	For Servo Motors with Holding Brakes	3 m	JZSP-CSM11-03-E	JZSP-CSM31-03-E	YAI-CSM31-03-P-E	
		5 m	JZSP-CSM11-05-E	JZSP-CSM31-05-E	YAI-CSM31-05-P-E	
		10 m	JZSP-CSM11-10-E	JZSP-CSM31-10-E	YAI-CSM31-10-P-E	
		15 m	JZSP-CSM11-15-E	JZSP-CSM31-15-E	YAI-CSM31-15-P-E	
		20 m	JZSP-CSM11-20-E	JZSP-CSM31-20-E	YAI-CSM31-20-P-E	
		30 m	JZSP-CSM11-30-E	JZSP-CSM31-30-E	YAI-CSM31-30-P-E	
		40 m	JZSP-CSM11-40-E	JZSP-CSM31-40-E	YAI-CSM31-40-P-E	
50 m		JZSP-CSM11-50-E	JZSP-CSM31-50-E	YAI-CSM31-50-P-E		
SGM7P-02 and -04 200 W, 400 W		3 m	JZSP-CSM12-03-E	JZSP-CSM32-03-E	YAI-CSM32-03-P-E	
		5 m	JZSP-CSM12-05-E	JZSP-CSM32-05-E	YAI-CSM32-05-P-E	
		10 m	JZSP-CSM12-10-E	JZSP-CSM32-10-E	YAI-CSM32-10-P-E	
		15 m	JZSP-CSM12-15-E	JZSP-CSM32-15-E	YAI-CSM32-15-P-E	
		20 m	JZSP-CSM12-20-E	JZSP-CSM32-20-E	YAI-CSM32-20-P-E	
		30 m	JZSP-CSM12-30-E	JZSP-CSM32-30-E	YAI-CSM32-30-P-E	
		40 m	JZSP-CSM12-40-E	JZSP-CSM32-40-E	YAI-CSM32-40-P-E	
50 m		JZSP-CSM12-50-E	JZSP-CSM32-50-E	YAI-CSM32-50-P-E		
SGM7P-08 750 W		3 m	N/A	N/A	B4IBCE-03(A)	
		5 m	N/A	N/A	B4IBCE-05(A)	
		10 m	N/A	N/A	B4IBCE-10(A)	
		15 m	N/A	N/A	B4IBCE-15(A)	
		20 m	N/A	N/A	B4IBCE-20(A)	
		30 m	N/A	N/A	B4IBCE-30(A)	
		40 m	N/A	N/A	B4IBCE-40(A)	
50 m		N/A	N/A	B4IBCE-50(A)		
SGM7P-15 1.5 kW		3 m	N/A	N/A	B5IBCE-03(A)	
		5 m	N/A	N/A	B5IBCE-05(A)	
		10 m	N/A	N/A	B5IBCE-10(A)	
		15 m	N/A	N/A	B5IBCE-15(A)	
	20 m	N/A	N/A	B5IBCE-20(A)		
	30 m	N/A	N/A	B5IBCE-30(A)		
	40 m	N/A	N/A	B5IBCE-40(A)		
50 m	N/A	N/A	B5IBCE-50(A)			

\* Use Flexible Cables for moving parts of machines, such as robots.

## Encoder Cables of 20 m or Less

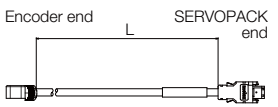
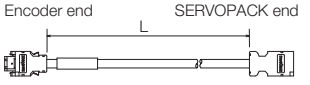
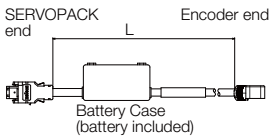
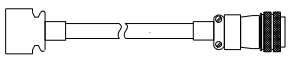
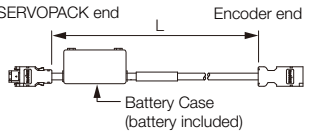
Servo Motor Model	Name	Length (L)	Order Number		Appearance
			Standard Cable	Flexible Cable* <sup>1</sup>	
SGM7P-01, -02 and -04 100 W, 200 W, 400 W	For incremental encoder	3 m	JZSP-C7PI0D-03-E	JZSP-C7PI2D-03-E	
		5 m	JZSP-C7PI0D-05-E	JZSP-C7PI2D-05-E	
		10 m	JZSP-C7PI0D-10-E	JZSP-C7PI2D-10-E	
		15 m	JZSP-C7PI0D-15-E	JZSP-C7PI2D-15-E	
		20 m	JZSP-C7PI0D-20-E	JZSP-C7PI2D-20-E	
SGM7P-08 and -15 750 W, 1500 W (non-Interconnectron style)	Cable installed toward load	3 m	JZSP-CMP00-03-E	JZSP-CMP10-03-E	
		5 m	JZSP-CMP00-05-E	JZSP-CMP10-05-E	
		10 m	JZSP-CMP00-10-E	JZSP-CMP10-10-E	
		15 m	JZSP-CMP00-15-E	JZSP-CMP10-15-E	
		20 m	JZSP-CMP00-20-E	JZSP-CMP10-20-E	
SGM7P-01, -02 and -04 100 W, 200 W, 400 W	For absolute encoder: With Battery Case* <sup>2</sup>	3 m	JZSP-C7PA0D-03-E	JZSP-C7PA2D-03-E	
	Cable installed toward load	5 m	JZSP-C7PA0D-05-E	JZSP-C7PA2D-05-E	
		10 m	JZSP-C7PA0D-10-E	JZSP-C7PA2D-10-E	
		15 m	JZSP-C7PA0D-15-E	JZSP-C7PA2D-15-E	
		20 m	JZSP-C7PA0D-20-E	JZSP-C7PA2D-20-E	
SGM7P-08 and -15 750 W, 1500 W (Interconnectron style)	For incremental encoder Cable installed upward* <sup>3</sup>	3 m	N/A	A1ICE-03(A)	
		5 m	N/A	A1ICE-05(A)	
		10 m	N/A	A1ICE-10(A)	
		15 m	N/A	A1ICE-15(A)	
		20 m	N/A	A1ICE-20(A)	
All SGM7P models	Cable with a Battery Case (Required when an absolute encoder is used.* <sup>4</sup> )	0.3 m	JZSP-CSP12-E Note: this cable used with A1ICE cable listed above		



\*1. Use Flexible Cables for moving parts of machines, such as robots.

\*2. If a battery is connected to the host controller, the Battery Case is not required. If so, use a cable for incremental encoders

\*3. Non RoHS.

\*4. This cable is not required if a battery is connected to the host controller.

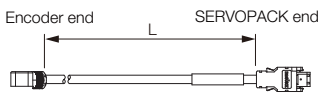
## Relay Encoder Cables of 30 m to 50 m

Servo Motor Model	Name	Length (L)	Order Number	Appearance
SGM7P-01, -02 and -04 100 W, 200 W, 400 W,*	Encoder-end Cable (for incremental or absolute encoder) Cable installed toward load	0.3 m	JZSP-C7PRCD-E	
	Cables with Connectors on Both Ends (for incremental or absolute encoder)	30 m	JZSP-UCMP00-30-E	
		40 m	JZSP-UCMP00-40-E	
		50 m	JZSP-UCMP00-50-E	

\* Note: Relay encoder cables not available for 750W and 1.5kW models.

# SGM7G

## SGM7G Servo Motors (without Gear Box)

### Model Designations

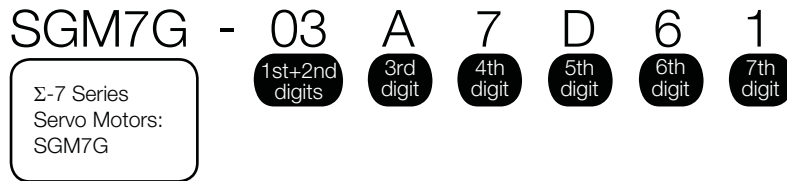

**1st+2nd digits** Rated Output

Code	Specification
03	300 W
05	450 W
09	850 W
13	1.3 kW
20	1.8 kW
30	2.9 kW <sup>*1</sup>
44	4.4 kW
55	5.5 kW
75	7.5 kW
1A	11 kW
1E	15 kW

**3rd digit** Power Supply Voltage

Code	Specification
A	200 VAC

**4th digit** Serial Encoder

Code	Specification
7	24-bit absolute
F	24-bit incremental

**5th digit** Design Revision Order

D: Global design revision

■ Non Stock Items

**6th digit** Shaft End

Code	Specification
2	Straight without key
6	Straight with key and tap
K <sup>*2</sup>	Straight with key and tap w/ same diameter as Sigma-5

**7th digit** Options

Code	Specification
1	Without options
C	With holding brake (24 VDC)
E	With oil seal and holding brake (24 VDC)
S	With oil seal

\*1. The rated output is 2.4 kW if you combine the SGM7G-30A with the SGD7S-200A.

\*2. Shaft end specification K is standard on -03, -09, and -13 Models



## SGM7G Gear Motors

The SGM7G gear motor product family pairs SGM7G servo motors with high precision, low backlash inline planetary gear heads resulting in a portfolio of rotary actuators fit for a wide range of applications. The family of gear motors has been thoroughly tested and adheres to the high levels of quality and performance expected from Yaskawa.

The high precision gear heads offer a variety of application advantages:

- ① **Quiet operation** – helical cut gears contribute toward reduced vibration and noise
- ② **High precision** – a standard backlash of 5 arc-min make this gear head ideal for the most accurate applications
- ③ **High rigidity and torque capacity** – achieved with a design which incorporates uncaged needle roller bearings
- ④ **Optimized adapter bushing** – minimizes inertia allowing for more output torque to be realized
- ⑤ **No leakage through the seal** – high viscosity, anti-separation grease does not liquefy and does not migrate away from the gears
- **Maintenance-free** – no need to replace the grease for the life of the unit. The reducer can be positioned in any orientation

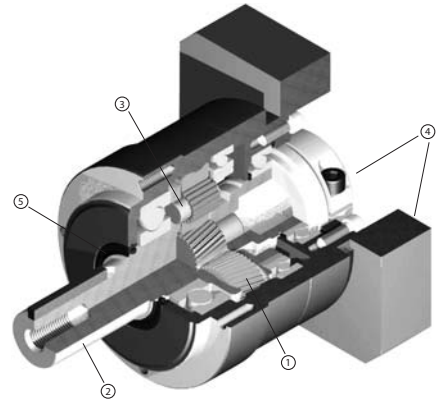

## Model Designations

S7G 01 A C - VL 050 - 05

Σ-7 Series  
Gear Motors:  
SGM7G

1st+2nd  
digits

3rd  
digit

4th  
digit

5th  
digit

6th  
digit

7th  
digit

1st+2nd digits Rated Output

Code	Specification
05	450 W
09	850 W
13	1.3 kW
20	1.8 kW
30	2.9 kW
44	4.4 kW
55	5.5 kW
75	7.5 kW

3rd digit Power Supply Voltage

Code	Specification
A	200 VAC

4th digit Brake Option

Code	Specification
Blank	No brake
C	24 V Brake

5th digit Gear box backlash

Code	Specification
VL	5 arc-min backlash

6th digit Gear head frame size

Code	Specification
070	70 mm
090	90 mm
120	120 mm
155	155 mm
205	205mm
235	235mm

7th digit Gear Ratio

Code	Specification
03	3:1 Ratio
05	5:1 Ratio
10	10:1 Ratio
25	25:1 Ratio
50	50:1 Ratio

## Specifications and Ratings

### Specifications

Voltage		200 V										
Model SGM7G-		03A	05A	09A	13A	20A	30A	44A	55A	75A	1AA	1EA
Time Rating		Continuous										
Thermal Class		UL: F, CE: F										
Insulation Resistance		500 VDC, 10 MΩmin.										
Withstand Voltage		1,500 VAC for 1 minute										
Excitation		Permanent magnet										
Mounting		Flange-mounted										
Drive Method		Direct drive										
Rotation Direction		Counterclockwise (CCW) for forward reference when viewed from the load side										
Vibration Class*1		V15										
Environmental Conditions	Surrounding Air Temperature	0°C to 40°C (With derating, usage is possible between 40°C and 60°C.) <sup>4</sup>										
	Surrounding Air Humidity	20% to 80% relative humidity (with no condensation)										
	Installation Site	<ul style="list-style-type: none"> <li>• Must be indoors and free of corrosive and explosive gases.</li> <li>• Must be well-ventilated and free of dust and moisture.</li> <li>• Must facilitate inspection and cleaning.</li> <li>• Must have an altitude of 1,000 m or less. (With derating, usage is possible between 1,000 m and 2,000 m.)<sup>5</sup></li> <li>• Must be free of strong magnetic fields.</li> </ul>										
	Storage Environment	Store the Servo Motor in the following environment if you store it with the power cable disconnected. Storage Temperature: -20°C to 60°C (with no freezing) Storage Humidity: 20% to 80% relative humidity (with no condensation)										
Shock Resistance*2	Impact Acceleration Rate at Flange	490 m/s <sup>2</sup>										
	Number of Impacts	2 times										
Vibration Resistance*3	Vibration Acceleration Rate at Flange	49 m/s <sup>2</sup> (24.5 m/s <sup>2</sup> front to back)					24.5 m/s <sup>2</sup>					
Applicable SERVOPACKS	SGD7S-	3R8A	7R6 A	120 A	180 A	330A	470 A	550 A	590 A	780 A		
	SGD7W-	5R5A <sup>6</sup> 7R6A <sup>6</sup>	7A6 A	-								

\*1. A vibration class of V15 indicates a vibration amplitude of 15 μm maximum on the Servo Motor without a load at the rated motor speed.

\*2. The shock resistance for shock in the vertical direction when the Servo Motor is mounted with the shaft in a horizontal position is given in the above table.

\*3. The vertical, side-to-side, and front-to-back vibration resistance for vibration in three directions when the Servo Motor is mounted with the shaft in a horizontal position is given in the above table. The strength of the vibration that the Servo Motor can withstand depends on the application. Always check the vibration acceleration rate that is applied to the Servo Motor with the actual equipment.

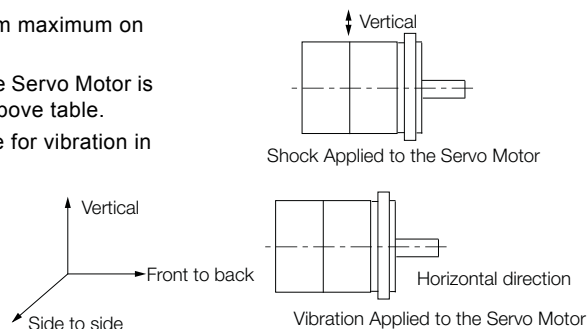

\*4. If the surrounding air temperature will exceed 40°C, refer to the following section.

☞ Applications Where the Surrounding Air Temperature of the Servo Motor Exceeds 40°C (page 118)

\*5. If the altitude will exceed 1,000 m, refer to the following section.

☞ Applications Where the Altitude of the Servo Motor Exceeds 1,000 m (page 119)

\*6. If you use a S-7W SERVOPACK, the control gain may not increase as much as with a S-7S SERVOPACK and other performances may be lower than those achieved with a S-7S SERVOPACK.

## Servo Motor Ratings

Voltage		200 V				
Model SGM7G-		03A	05A	09A	13A	20A
Rated Output <sup>*1</sup>	kW	0.3	0.45	0.85	1.3	1.8
Rated Torque <sup>*1, *2</sup>	N•m	1.96	2.86	5.39	8.34	11.5
Instantaneous Maximum Torque <sup>*1</sup>	N•m	5.88	8.92	14.2	23.3	28.7
Rated Current <sup>*1</sup>	Arms	2.8	3.8	6.9	10.7	16.7
Instantaneous Maximum Current <sup>*1</sup>	Arms	8.0	11	17	28	42
Rated Motor Speed <sup>*1</sup>	min <sup>-1</sup>	1500				
Maximum Motor Speed <sup>*1</sup>	min <sup>-1</sup>	3000				
Torque Constant	N•m/Arms	0.776	0.854	0.859	0.891	0.748
Motor Moment of Inertia	$\times 10^{-4}$ kg•m <sup>2</sup>	2.48 (2.73)	3.33 (3.58)	13.9 (16.0)	19.9 (22.0)	26.0 (28.1)
Rated Power Rate <sup>*1</sup>	kW/s	15.5 (14.1)	24.6 (22.8)	20.9 (18.2)	35.0 (31.6)	50.9 (47.1)
Rated Angular Acceleration Rate <sup>*1</sup>	rad/s <sup>2</sup>	7900 (7180)	8590 (7990)	3880 (3370)	4190 (3790)	4420 (4090)
Heat Sink Size	mm	250 × 250 × 6 (aluminum)		400 × 400 × 20 (steel)		
Protective Structure <sup>*3</sup>		Totally enclosed, self-cooled, IP67				
Holding Brake Specifications <sup>*4</sup>	Rated Voltage	V	24 VDC $^{+10\%}_0$			
	Capacity	W	10			
	Holding Torque	N•m	4.5	12.7	19.6	
	Coil Resistance	$\Omega$ (at 20°C)	56	59		
	Rated Current	A (at 20°C)	0.43	0.41		
	Time Required to Release Brake	ms	100			
Time Required to Brake	ms	80				
Allowable Load Moment of Inertia (Motor Moment of Inertia Ratio)		15 times	15 times	5 times		
Allowable Shaft Loads <sup>*5</sup>	LF	mm	40		58	
	Allowable Radial Load	N	490		686	980
	Allowable Thrust Load	N	98		343	392

Note: 1. The values in parentheses are for Servo Motors with Holding Brakes.

2. Refer to the following section for footnotes \*1 to \*5.

 ■ Notes for the Servo Motor Ratings Tables (page 114)

## Torque-Motor Speed Characteristics for Three-phase, 200 V

**A** : Continuous duty zone

**B** : Intermittent duty zone

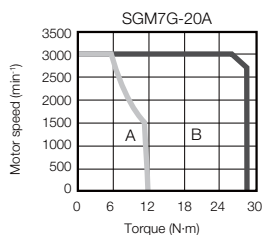
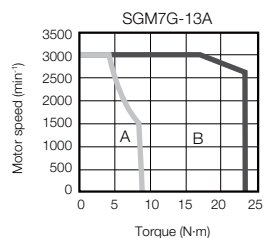
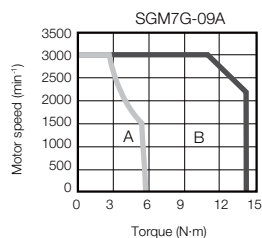
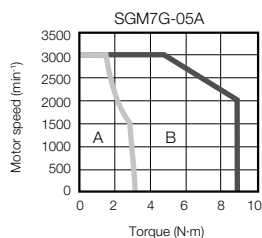
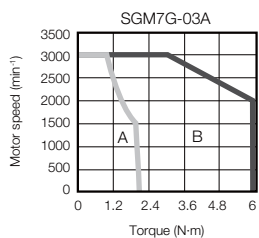

Note: 1. These values are for operation in combination with a SERVOPACK when the temperature of the armature winding is 20°C. These are typical values.

2. The characteristics in the intermittent duty zone depend on the power supply voltage.

3. If the effective torque is within the allowable range for the rated torque, the Servo Motor can be used within the intermittent duty zone.

4. If you use a Servo Motor Main Circuit Cable that exceeds 20 m, the intermittent duty zone in the torque-motor speed characteristics will become smaller because the voltage drop increases.

## Servo Motor Ratings

Voltage		200 V						
Model SGM7G-		30A	30A <sup>*6</sup>	44A	55A	75A	1AA	1EA
Rated Output <sup>*1</sup>	kW	2.9	2.4	4.4	5.5	7.5	11	15
Rated Torque <sup>*1, *2</sup>	N•m	18.6	15.1	28.4	35.0	48.0	70.0	95.4
Instantaneous Maximum Torque <sup>*1</sup>	N•m	54.0	45.1	71.6	102	119	175	224
Rated Current <sup>*1</sup>	Arms	23.8	19.6	32.8	37.2	54.7	58.6	78.0
Instantaneous Maximum Current <sup>*1</sup>	Arms	70	56	84	110	130	140	170
Rated Motor Speed <sup>*1</sup>	min <sup>-1</sup>	1500	1500	1500	1500	1500	1500	1500
Maximum Motor Speed <sup>*1</sup>	min <sup>-1</sup>	3000	3000	3000	3000	3000	2000	2000
Torque Constant	N•m/Arms	0.848	0.848	0.934	1.00	0.957	1.38	1.44
Motor Moment of Inertia	×10 <sup>-4</sup> kg•m <sup>2</sup>	46.0 (53.9)	46.0 (53.9)	67.5 (75.4)	89.0 (96.9)	125 (133)	242 (261)	303 (341)
Rated Power Rate <sup>*1</sup>	kW/s	75.2 (64.2)	49.5 (42.2)	119 (107)	138 (126)	184 (173)	202 (188)	300 (267)
Rated Angular Acceleration Rate <sup>*1</sup>	rad/s <sup>2</sup>	4040 (3450)	3280 (2800)	4210 (3770)	3930 (3610)	3840 (3610)	2890 (2680)	3150 (2800)
Heat Sink Size	mm	550 × 550 × 30 (steel)					650 × 650 × 35 (steel)	
Protective Structure <sup>*3</sup>	Totally enclosed, self-cooled, IP67							
Holding Brake Specifications <sup>*4</sup>	Rated Voltage	V	24 VDC <sup>+10%</sup> <sub>0</sub>					
	Capacity	W	18.5		25	32	35	
	Holding Torque	N•m	43.1		72.6	84.3	114.6	
	Coil Resistance	Ω (at 20°C)	31		23	18	17	
	Rated Current	A (at 20°C)	0.77		1.05	1.33	1.46	
	Time Required to Release Brake	ms	170					250
	Time Required to Brake	ms	100			80		
Allowable Load Moment of Inertia (Motor Moment of Inertia Ratio)			5 times	3 times	5 times			
	With External Regenerative Resistor and Dynamic Brake Resistor		10 times	7 times	10 times			
Allowable Shaft Loads <sup>*5</sup>	LF	mm	79		113	116		
	Allowable Radial Load	N	1470		1764		4998	
	Allowable Thrust Load	N	490		588		2156	

Note: 1. The values in parentheses are for Servo Motors with Holding Brakes.

2. Refer to the following section for footnotes \*1 to \*6.

 ■ Notes for the Servo Motor Ratings Tables (page 114)

## Torque-Motor Speed Characteristics

- A : Continuous duty zone      — (solid lines): With three-phase 200-V input  
B : Intermittent duty zone      - - - (dotted lines): When combined with the SGD7S-200A

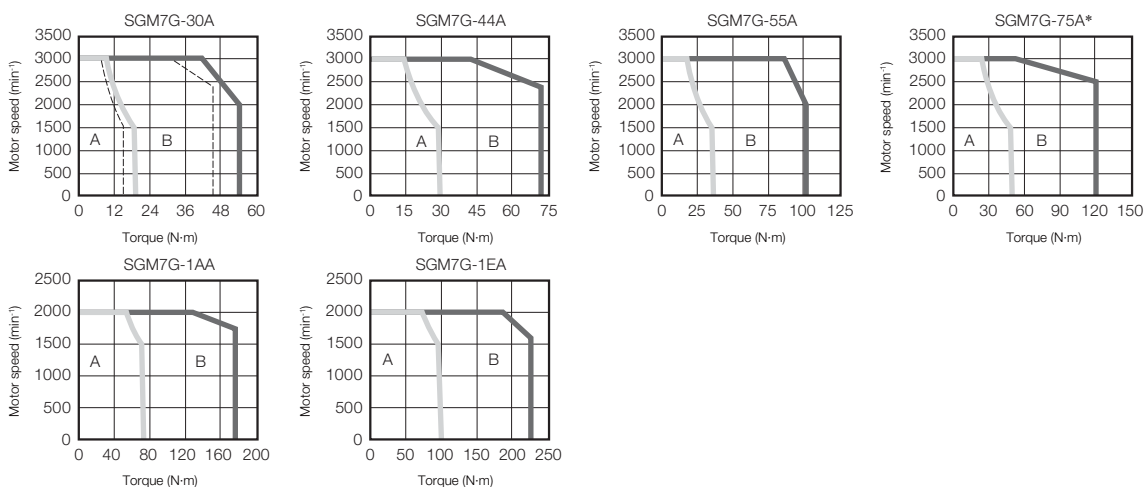

\* Use an SGM7G-75A Servo Motor with a Holding Brake with an output torque of 14.4 N·m (30% of the rated torque) or lower when using the Servo Motor in continuous operation at the maximum motor speed of 3,000 min<sup>-1</sup>.

Note: 1. These values are for operation in combination with a SERVOPACK when the temperature of the armature winding is 100°C. These are typical values.

2. The characteristics in the intermittent duty zone depend on the power supply voltage.
3. If the effective torque is within the allowable range for the rated torque, the Servo Motor can be used within the intermittent duty zone.
4. If you use a Servo Motor Main Circuit Cable that exceeds 20 m, the intermittent duty zone in the torque-motor speed characteristics will become smaller because the voltage drop increases.

### ■ Notes for the Servo Motor Ratings Tables

- \*1. These values are for operation in combination with a SERVOPACK when the temperature of the armature winding is 20°C. These are typical values.
- \*2. The rated torques are the continuous allowable torque values at a surrounding air temperature of 40°C with an aluminum or steel heat sink of the dimensions given in the table.
- \*3. This does not apply to the shaft opening. Protective structure specifications apply only when the special cable is used.
- \*4. Observe the following precautions if you use a Servo Motor with a Holding Brake.
  - The holding brake cannot be used to stop the Servo Motor.
  - The time required to release the brake and the time required to brake depend on which discharge circuit is used. Confirm that the operation delay time is appropriate for the actual equipment.
  - The 24-VDC power supply is not provided by Yaskawa.
- \*5. The allowable shaft loads are illustrated in the following figure. Design the mechanical system so that the thrust and radial loads applied to the Servo Motor shaft end during operation do not exceed the values given in the table.

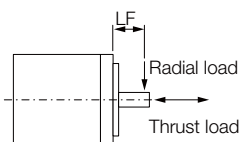

- \*6. This is the value if you combine the SGM7G-30A with the SGD7S-200A.

## Ratings of Gear Motors (200 V Models)

Gear Motor Model Number	Base Servo Motor Model (SGM7G-)	Gear Ratio	Gearing Efficiency <sup>*1</sup>	Rated Speed (RPM)	Max Speed (RPM)	Rated Torque (Nm) <sup>*2</sup>	Peak Torque (Nm) <sup>*2</sup>	Motor Inertia (x10 <sup>-4</sup> kg-m <sup>2</sup> )	Gear-head Inertia (x10 <sup>-4</sup> kg-m <sup>2</sup> )	Allowable Radial Load (N)	Allowable Axial Load (N)	Backlash (arc-min)	Protection Class
S7G05A□ -VL070-03	05A7D6□	3:1	95	500	1000	8.15	25.4	3.330 (3.580)	0.430	1200	1100	5	IP65
S7G05A□ -VL070-05		5:1		300	600	13.6	42.4		0.360				
S7G05A□ -VL090-10		10:1		150	300	27.2	84.7		0.750				
S7G05A□ -VL090-25		25:1	60	120	64.4	125 <sup>*3</sup>	0.710		2400	2200			
S7G05A□ -VL120-50		50:1	90	30	60	129	330 <sup>*3</sup>		0.730	4300	3900		
S7G09A□ -VL090-03	09A7DK□	3:1	95	500	1000	15.4	40.5	13.90 (16.00)	3.20	2400	2200		
S7G09A□ -VL090-05		5:1		300	600	25.6	67.5		2.90				
S7G09A□ -VL090-10		10:1		150	300	51.2	80.0 <sup>*3</sup>		2.80				
S7G09A□ -VL120-25		25:1	90	60	120	121	320		2.80	4300	3900		
S7G09A□ -VL155-50		50:1	30	60	243	639	2.80		9100	8200			
S7G13A□ -VL090-03	13A7DK□	3:1	95	500	1000	23.8	66.4	19.90 (22.00)	3.20	2400	1100		
S7G13A□ -VL090-05		5:1		300	600	39.6	111		2.90				
S7G13A□ -VL120-10		10:1		150	300	79.2	221		3.00	4300	3900		
S7G13A□ -VL120-25		25:1	90	60	120	188	330 <sup>*3</sup>		2.80	9100	8200		
S7G13A□ -VL155-50		50:1	30	60	375	700 <sup>*3</sup>	2.80		9100	8200			
S7G20A□ -VL090-03	20A7D6□	3:1	95	500	1000	32.8	81.8	26.00 (28.10)	3.20	2400	2200		
S7G20A□ -VL090-05		5:1		300	600	54.6	136		2.90				
S7G20A□ -VL120-10		10:1		150	300	109	225 <sup>*3</sup>		3.00	4300	3900		
S7G20A□ -VL155-25		25:1	90	60	120	259	646		3.10	9100	8200		
S7G20A□ -VL205-50		50:1	30	60	518	1292	2.80		15000	14000			
S7G30A□ -VL120-03	30A7D6□	3:1	95	500	1000	53.0	154	46.00 (53.90)	13.0	4300	3900		
S7G30A□ -VL120-05		5:1		300	600	88.4	257		11.0				
S7G30A□ -VL155-10		10:1		150	300	177	51 <sup>*3</sup>		14.0	9100	8200		
S7G30A□ -VL155-25		25:1	90	60	120	360 <sup>*3</sup>	700 <sup>*3</sup>		12.0	15000	14000		
S7G30A□ -VL205-50		50:1	30	60	750 <sup>*3</sup>	1400 <sup>*3</sup>	12.0		15000	14000			
S7G44A□ -VL120-03	44A7D6□	3:1	95	500	1000	80.9	204	67.50 (75.40)	13.0	4300	3900		
S7G44A□ -VL120-05		5:1		300	600	135	340		11.0				
S7G44A□ -VL205-10		10:1		150	300	270	680		14.0	15000	14000		
S7G44A□ -VL205-25		25:1	90	60	120	639	1400 <sup>*3</sup>		12.0	15000	14000		
S7G44A□ -VL235-50		50:1	20 <sup>*3</sup>	40 <sup>*3</sup>	1306	2300 <sup>*3</sup>	12.0		15000	14000			
S7G55A□ -VL155-03	55A7D6□	3:1	95	500	1000	99.8	291	89.00 (96.90)	42.0	9100	8200		
S7G55A□ -VL155-05		5:1		300	600	166	485		36.0				
S7G55A□ -VL205-10		10:1		150	300	333	969		36.0	15000	14000		
S7G55A□ -VL205-25		25:1	90	60	120	788	1400 <sup>*3</sup>		34.0	15000	14000		
S7G55A□ -VL235-50		50:1	20 <sup>*3</sup>	40 <sup>*3</sup>	1610	2300 <sup>*3</sup>	33.0		15000	14000			
S7G75A□ -VL155-03	75A7D6□	3:1	95	500	1000	137	339	125.0 (133.0)	42.0	9100	8200		
S7G75A□ -VL155-05		5:1		300	600	228	565		36.0				
S7G75A□ -VL205-10		10:1		150	300	456	970 <sup>*3</sup>		36.0	15000	14000		
S7G75A□ -VL235-25		25:1	90	40 <sup>*3</sup>	80 <sup>*3</sup>	1104	2300 <sup>*3</sup>		35.0	15000	14000		
S7G75A□ -VL235-50		50:1	20 <sup>*3</sup>	40 <sup>*3</sup>	1500 <sup>*3</sup>	2300 <sup>*3</sup>	33.0		15000	14000			

Note: The values in parentheses are for Servo Motors with Holding Brakes (indicated by value of □ in model numbers).

\*1. The gear efficiency depends on operating conditions such as the output torque, motor speed, and temperature.

\*2. The gear motor output torque is expressed by the following formula: Output Torque = (Servo Motor Output Torque) x (Gearing Ratio) x (Gearing Efficiency). The values in the table are typical values for the rated torque, rated motor speed, and a surrounding air temperature of 25°C. They are reference values only.

\*3. The output torque of the gear motor is limited by the mechanical limit of the gear head. Operation above this limit could result in premature failure of the gear motor.



Important

During operation of the gear motor, losses due to inefficiencies of the gearing mechanism are generated. The losses vary as the conditions for gear motor torque and speed change. Temperature rise can vary based on the mechanical inefficiencies and the heat dissipation conditions. For heat dissipation conditions, check the gear and motor temperatures with the actual equipment. If operating temperatures are too high, implement the following measures.

- Decrease the load ratio.
- Change the heat dissipation conditions.
- Use forced-air cooling for the motor with a cooling fan or other means.



## Servo Motor Overload Protection Characteristics

The overload detection level is set for hot start conditions with a Servo Motor surrounding air temperature of 40°C.

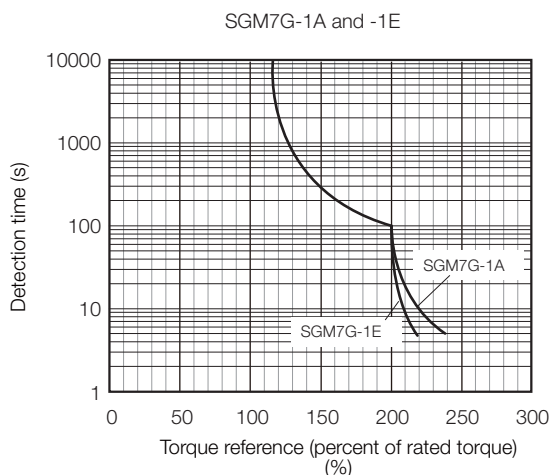
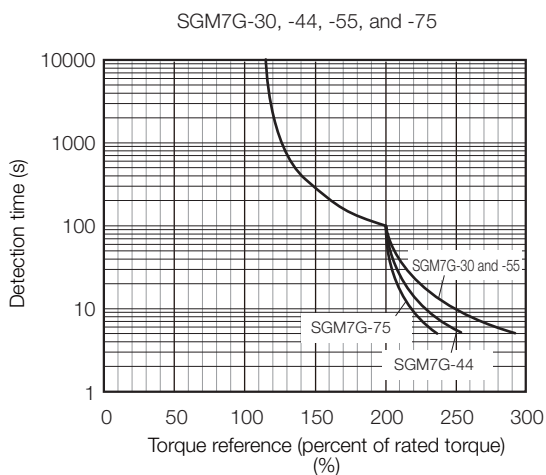
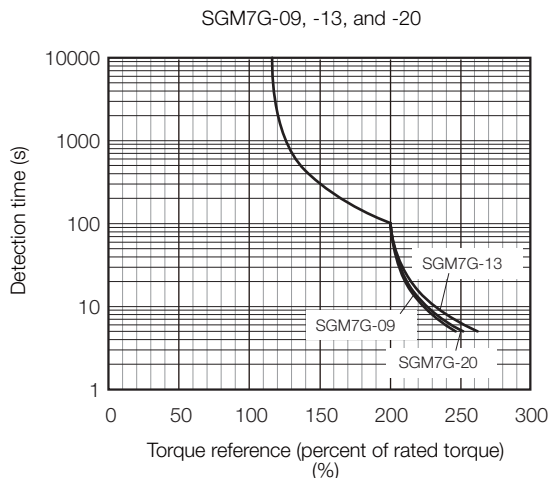
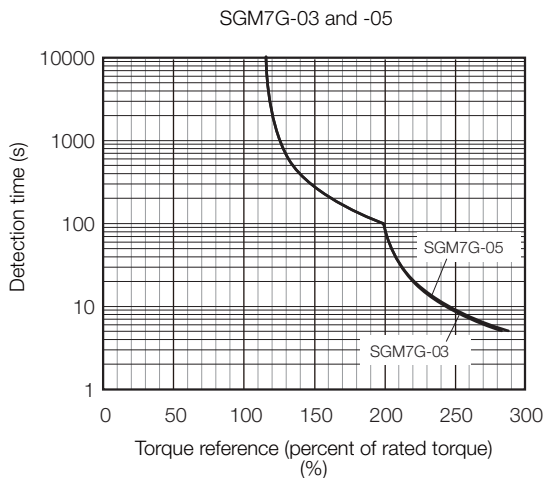

Note: The above overload protection characteristics do not mean that you can perform continuous duty operation with an output of 100% or higher. Use the Servo Motor so that the effective torque remains within the continuous duty zone given in *Torque-Motor Speed Characteristics for Three-phase, 200 V* on page 112.

## Servo Motor Heat Dissipation Conditions

The Servo Motor ratings are the continuous allowable values at a surrounding air temperature of 40°C when a heat sink is installed on the Servo Motor. If the Servo Motor is mounted on a small device component, the Servo Motor temperature may rise considerably because the surface for heat dissipation becomes smaller. Refer to the following graphs for the relation between the heat sink size and derating rate.

When using Servo Motors with derating, change the detection timing of overload warnings and overload alarms by referring to the motor overload detection level described in the following manual.

📖 *Σ-7-Series AC Servo Drive Rotary Servo Motor Product Manual* (Manual No.: SIEP S800001 36)

Note: The derating rates are applicable only when the average motor speed is less than or equal to the rated motor speed. If the average motor speed exceeds the rated motor speed, consult with your Yaskawa representative.



Important

The actual temperature rise depends on how the heat sink (i.e., the Servo Motor mounting section) is attached to the installation surface, what material is used for the Servo Motor mounting section, and the motor speed. Always check the Servo Motor temperature with the actual equipment.

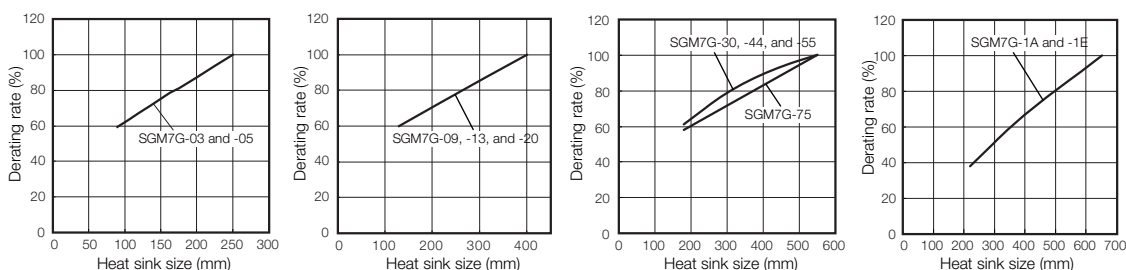

## Applications Where the Surrounding Air Temperature of the Servo Motor Exceeds 40°C

The Servo Motor ratings are the continuous allowable values at a surrounding air temperature of 40°C. If you use a Servo Motor at a surrounding air temperature that exceeds 40°C (60°C max.), apply a suitable derating rate from the following graphs.

When using Servo Motors with derating, change the detection timing of overload warnings and overload alarms by referring to the motor overload detection level described in the following manual.

📖 *Σ-7-Series AC Servo Drive Rotary Servo Motor Product Manual* (Manual No.: SIEP S800001 36)

Note: 1. Use the combination of the SERVOPACK and Servo Motor so that the derating conditions are satisfied for both the SERVOPACK and Servo Motor.

2. The derating rates are applicable only when the average motor speed is less than or equal to the rated motor speed. If the average motor speed exceeds the rated motor speed, consult with your Yaskawa representative.

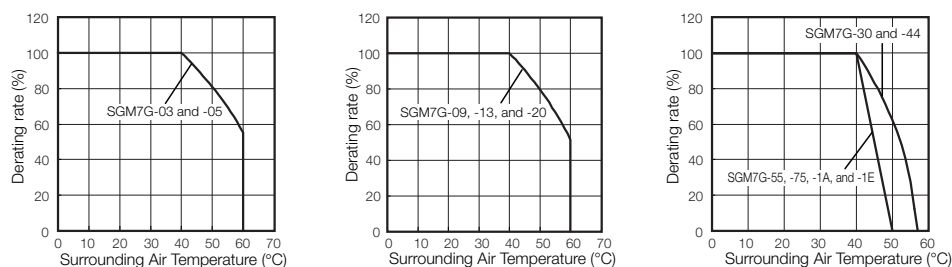

## Applications Where the Altitude of the Servo Motor Exceeds 1,000 m

The Servo Motor ratings are the continuous allowable values at an altitude of 1,000 m or less. If you use a Servo Motor at an altitude that exceeds 1,000 m (2,000 m max.), the heat dissipation effect of the air is reduced. Apply the appropriate derating rate from the following graphs.

When using Servo Motors with derating, change the detection timing of overload warnings and overload alarms by referring to the motor overload detection level described in the following manual.

📖 *Σ-7-Series AC Servo Drive Rotary Servo Motor Product Manual* (Manual No.: SIEP S800001 36)

Note: 1. Use the combination of the SERVOPACK and Servo Motor so that the derating conditions are satisfied for both the SERVOPACK and Servo Motor.

2. The derating rates are applicable only when the average motor speed is less than or equal to the rated motor speed. If the average motor speed exceeds the rated motor speed, consult with your Yaskawa representative.

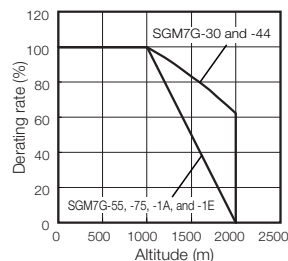
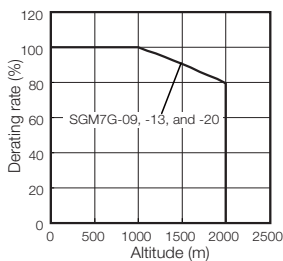
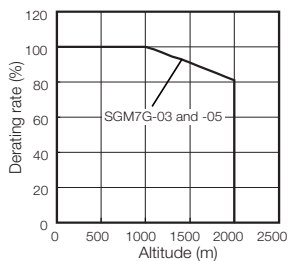

## External Dimensions

### Servo Motors without Holding Brakes

◆ SGM7G-03 and -05

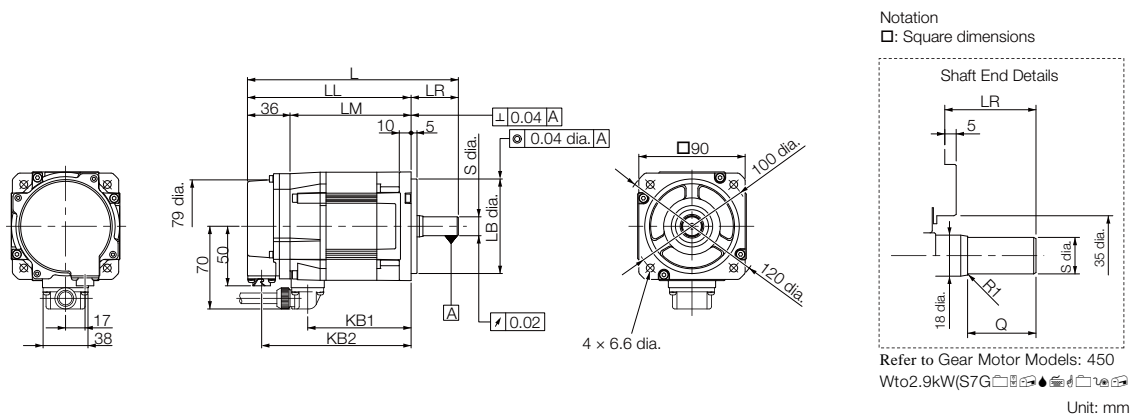

Model SGM7G-	L	LL	LM	LR	KB1	KB2	KL1	Flange Dimensions			
								LA	LB	LC	LE
03A□A21	166*	126	90	40*	75	114	70	100	80 <sup>0</sup> <sub>-0.030</sub>	90	5
05A□A21	179	139	103	40	88	127	70	100	80 <sup>0</sup> <sub>-0.030</sub>	90	5

Model SGM7G-	Flange Dimensions			Shaft End Dimensions		Approx. Mass [kg]
	LG	LH	LZ	S	Q	
03A□A21	10	120	6.6	14 <sup>0</sup> <sub>-0.011</sub> *	30*	2.6
05A□A21	10	120	6.6	16 <sup>0</sup> <sub>-0.011</sub>	30	3.2

Note: Servo Motors with Oil Seals have the same dimensions.

\* The L, LR, S, and Q dimensions of these Servo Motors are different from those of the S-V-series SGMGV Servo Motors. Models that have the same installation dimensions as the SGMGV Servo Motors are also available. Contact your Yaskawa representative for details.

Refer to the following section for information on connectors.

☞ ◆ SGM7G-03 and -05 without Holding Brakes (page 133)

◆ SGM7G-09 to -75

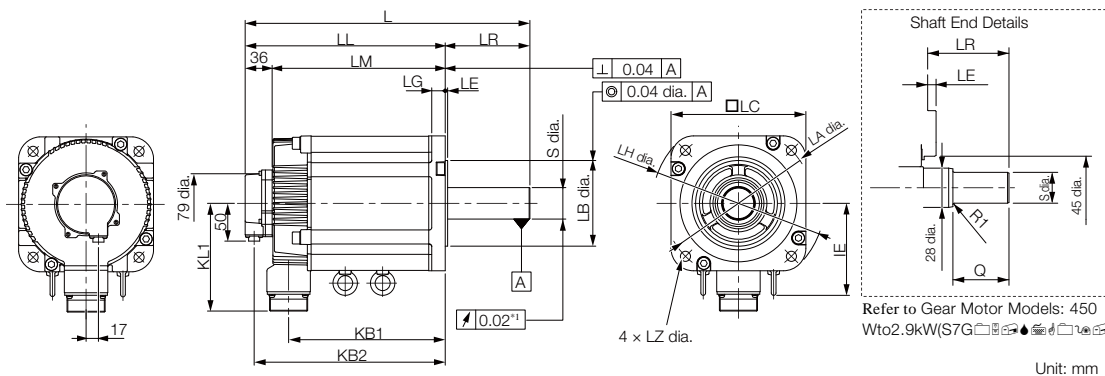

Model SGM7G-	L	LL	LM	LR	KB1	KB2	IE	KL1	Flange Dimensions			
									LA	LB	LC	LE
09A□A21	195	137	101	58	83	125	-	104	145	110 <sup>0</sup> <sub>-0.035</sub>	130	6
13A□A21	211	153	117	58	99	141	-	104	145	110 <sup>0</sup> <sub>-0.035</sub>	130	6
20A□A21	229	171	135	58	117	159	-	104	145	110 <sup>0</sup> <sub>-0.035</sub>	130	6
30A□A21	239	160	124	79	108	148	-	134	200	114.3 <sup>0</sup> <sub>-0.025</sub>	180	3.2
44A□A21	263	184	148	79	132	172	-	134	200	114.3 <sup>0</sup> <sub>-0.025</sub>	180	3.2
55A□A21	334	221	185	113	163	209	123	144	200	114.3 <sup>0</sup> <sub>-0.025</sub>	180	3.2
75A□A21	380	267	231	113	209	255	123	144	200	114.3 <sup>0</sup> <sub>-0.025</sub>	180	3.2

Model SGM7G-	Flange Dimensions			Shaft End Dimensions		Approx. Mass [kg]
	LG	LH	LZ	S	Q	
09A□A21	12	165	9	19 <sup>0</sup> <sub>-0.013</sub>	40	5.5
13A□A21	12	165	9	22 <sup>0</sup> <sub>-0.013</sub>	40	7.1
20A□A21	12	165	9	24 <sup>0</sup> <sub>-0.013</sub>	40	8.6
30A□A21	18	230	13.5	35 <sup>+0.01</sup> <sub>0</sub>	76	13.5
44A□A21	18	230	13.5	35 <sup>+0.01</sup> <sub>0</sub>	76	17.5
55A□A21	18	230	13.5	42 <sup>0</sup> <sub>-0.016</sub>	110	21.5
75A□A21	18	230	13.5	42 <sup>0</sup> <sub>-0.016</sub>	110	29.5

Note: Servo Motors with Oil Seals have the same dimensions.

\*1. This is 0.04 for the SGM7G-55 or SGM7G-75.



## Servo Motors with Holding Brakes

### ◆ SGM7G-03 and -05

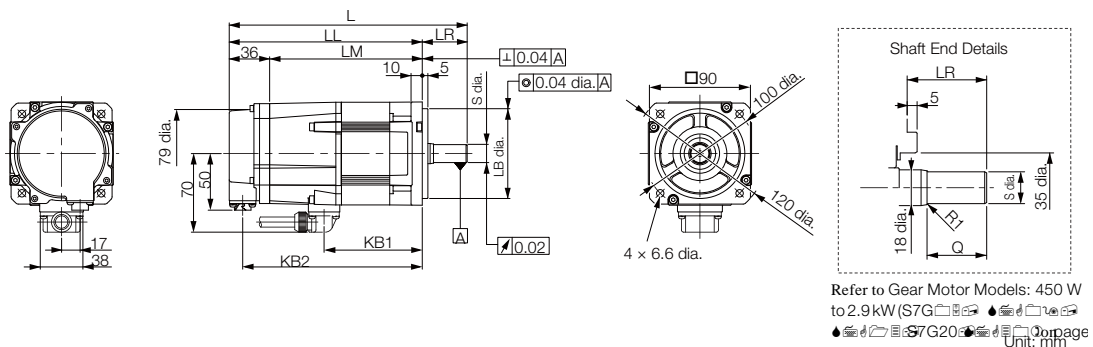

Model SGM7G-	L	LL	LM	LR	KB1	KB2	KL1	Flange Dimensions			
								LA	LB	LC	LE
1AA□A21	163	159	123	37	75	147	70	100	80 <sup>0</sup> <sub>-0.030</sub>	90	5
1AA□A21	212	172	136	40	88	160	70	100	80 <sup>0</sup> <sub>-0.030</sub>	90	5

Model SGM7G-	Flange Dimensions			Shaft End Dimensions		Approx. Mass [kg]
	LG	LH	LZ	S	Q	
1AA□A21	10	120	6.6	14 <sup>0</sup> <sub>-0.011</sub> *	25	3.6
1AA□A21	10	120	6.6	16 <sup>0</sup> <sub>-0.011</sub>	30	4.2

Note: Servo Motors with Oil Seals have the same dimensions.  
Refer to the following section for information on connectors.

◆ SGM7G-03 and -05 with Holding Brakes (page 134)

◆ SGM7G-09 to -75

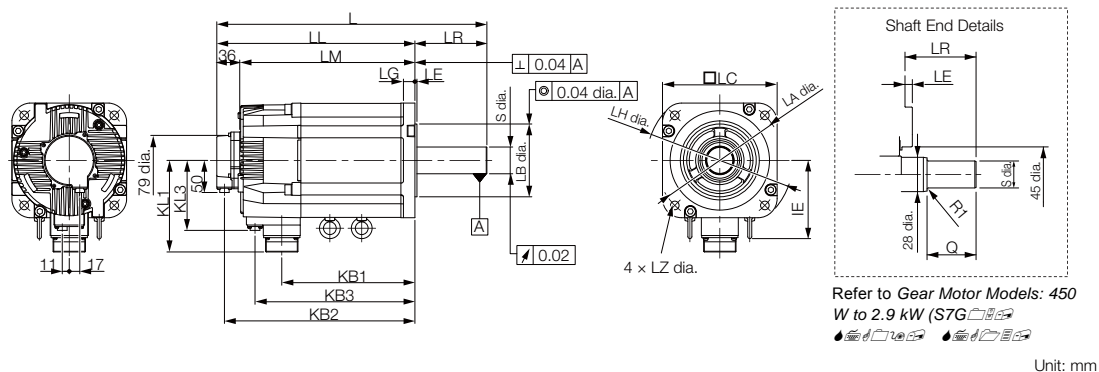

Model SGM7G-	L	LL	LM	LR	KB1	KB2	KB3	IE	KL1	KL3	Flange Dimensions			
											LA	LB	LC	LE
09A□A2C	231	173	137	58	83	161	115	-	104	80	145	110 <sup>0</sup> <sub>-0.035</sub>	130	6
13A□A2C	247	189	153	58	99	177	131	-	104	80	145	110 <sup>0</sup> <sub>-0.035</sub>	130	6
20A□A2C	265	207	171	58	117	195	149	-	104	80	145	110 <sup>0</sup> <sub>-0.035</sub>	130	6
30A□A2C	287	208	172	79	108	196	148	-	134	110	200	114.3 <sup>0</sup> <sub>-0.025</sub>	180	3.2
44A□A2C	311	232	196	79	132	220	172	-	134	110	200	114.3 <sup>0</sup> <sub>-0.025</sub>	180	3.2
55A□A2C	378	265	229	113	163	253	205	123	144	110	200	114.3 <sup>0</sup> <sub>-0.025</sub>	180	3.2
75A□A2C	424	311	275	113	209	299	251	123	144	110	200	114.3 <sup>0</sup> <sub>-0.025</sub>	180	3.2

Model SGM7G-	Flange Dimensions			Shaft End Dimensions		Approx. Mass [kg]
	LG	LH	LZ	S	Q	
09A□A2C	12	165	9	19 <sup>0</sup> <sub>-0.013</sub>	40	7.5
13A□A2C	12	165	9	22 <sup>0</sup> <sub>-0.013</sub>	40	9.0
20A□A2C	12	165	9	24 <sup>0</sup> <sub>-0.013</sub>	40	11.0
30A□A2C	18	230	13.5	35 <sup>+0.01</sup> <sub>0</sub>	76	19.5
44A□A2C	18	230	13.5	35 <sup>+0.01</sup> <sub>0</sub>	76	23.5
55A□A2C	18	230	13.5	42 <sup>0</sup> <sub>-0.016</sub>	110	27.5
75A□A2C	18	230	13.5	42 <sup>0</sup> <sub>-0.016</sub>	110	35.0

Note: Servo Motors with Oil Seals have the same dimensions.



◆ SGM7G-1A, 1E

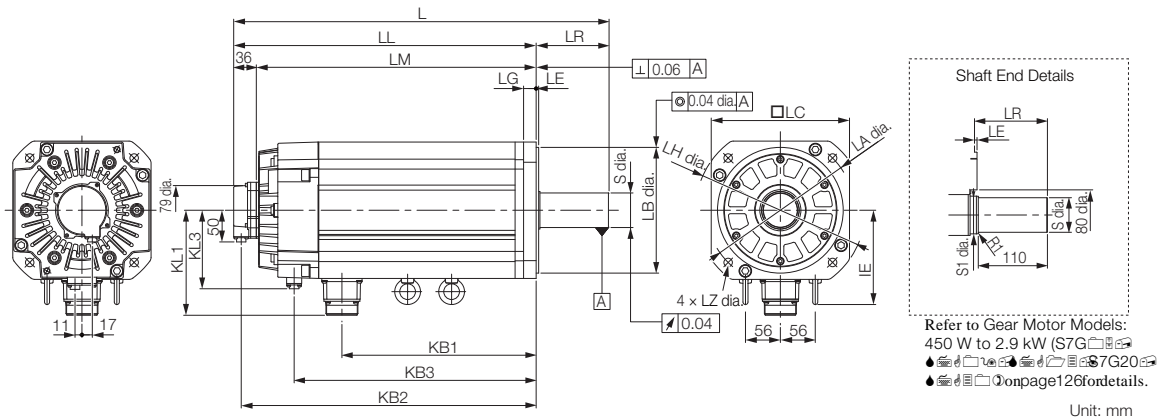

Model SGM7G-	L	LL	LM	LR	KB1	KB2	KB3	IE	KL1	KL3	Flange Dimensions			
											LA	LB	LC	LE
1AA□A2C	498	382	346	116	247	370	315	150	168	125	235	200 <sup>0</sup> <sub>-0.046</sub>	220	4
1EA□A2C	598	482	446	116	309	470	385	150	168	125	235	200 <sup>0</sup> <sub>-0.046</sub>	220	4

Model SGM7G-	Flange Dimensions			Shaft End Dimensions		Approx. Mass [kg]
	LG	LH	LZ	S	Q	
1AA□A21	20	270	13.5	42 <sup>0</sup> <sub>-0.016</sub>	50	65
1AA□A21	20	270	13.5	55 <sup>+0.030</sup> <sub>+0.011</sub>	60	85

Note: Servo Motors with Oil Seals have the same dimensions.

Refer to the following section for information on connectors.

☞ ◆ SGM7G-09 to -1E with Holding Brakes (page 134)

◆ Gear Motor Models: 450 W to 2.9 kW (S7G05, S7G09, S7G13, S7G20, S7G30)

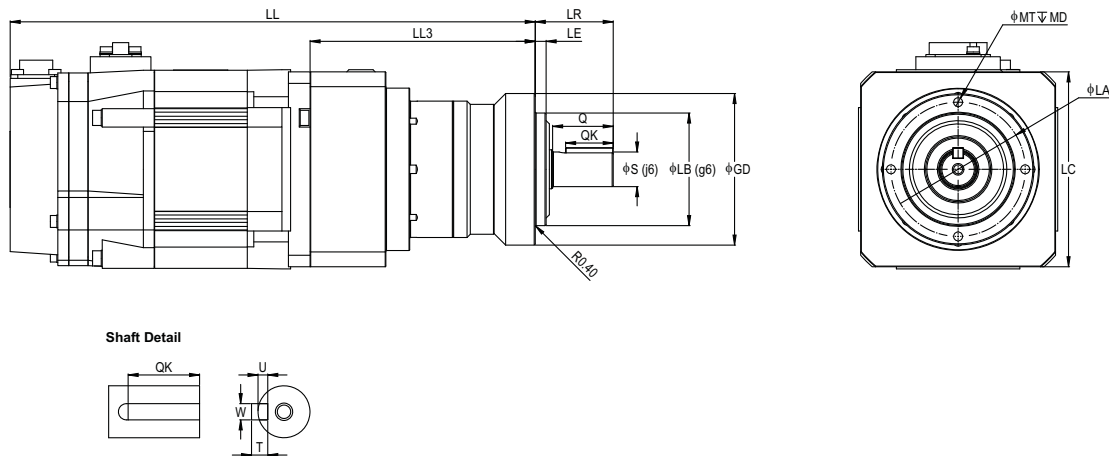

Model S7G	LL	LL3	LR	LE	φS	φLB	φGD	LC	φLA	φMT	MD	Q	QK	KD	W	U	T		
450 W Models																			
200 V	05A□ -VL070-03	243 (276)	104	36	5	16	52	90	62	M5	10	28	22	0	5	3	5		
	05A□ -VL070-05																		
	05A□ -VL090-10	256 (289)	117	46	7	22	68		90	80	M6	12	36		28		6	3.5	6
	05A□ -VL090-25	278 (311)	139																
05A□ -VL120-50	293.5 (326.5)	154.5	70	9	32	90	120		108	M8	16	58	45		10	5	8		
850 W Models																			
200 V	09A□ -VL090-03	259 (295)	122	46	7	22	68	130	80	M6	12	36	28	0	6	3.5	6		
	09A□ -VL090-05																		
	09A□ -VL090-10																		
	09A□ -VL120-25	296.5 (332.5)	159.5	70	9	32	90		120	108	M8	16	58		45		10	5	8
09A□ -VL155-50	321.5 (357.5)	184.5	97	12	40	120	155		140	M10	20	82	65		12				
1.3 kW Models																			
200 V	13A□ -VL090-03	287 (323)	134	46	7	22	68	130	80	M6	12	36	28	0	6	3.5	6		
	13A□ -VL090-05																		
	13A□ -VL120-10	297 (333)	144	70	9	32	90		120	108	M8	16	58		45		10	5	8
	13A□ -VL120-25	324.5 (360.5)	171.5																
13A□ -VL155-50	349.5 (385.5)	196.5	97	12	40	120	155		140	M10	20	82	65		12				
1.8 kW Models																			
200 V	20A□ -VL090-03	305 (341)	134	46	7	22	68	130	80	M6	12	36	28	0	6	3.5	6		
	20A□ -VL090-05																		
	20A□ -VL120-10	315 (351)	144	70	9	30	90		120	108	M8	16	58		45		10	5	8
	20A□ -VL155-25	367.5 (403.5)	196.5	97	12	40	120		155	140	M10	20	82		65		12		
20A□ -VL205-50	397 (433)	226	100	15	55	160	205		184	M12	22				16	6	10		
2.9 kW Models																			
200 V	30A□ -VL120-03	285 (363)	155	70	9	32	90	180	108	M8	16	58	45	0	10				
	30A□ -VL120-05																		
	30A□ -VL155-10	297 (375)	167	97	12	40	120		155	140	M10	20	82		65		12	5	8
	30A□ -VL155-25	331.5 (409.5)	201.5																
30A□ -VL205-50	361 (439)	231	100	15	55	160	205		184	M12	22				16	6	10		

Note: The values in parentheses are for Servo Motors with Holding Brakes. 7.0kW motors not available with brake.

◆ Gear Motor Models: 4.4 kW to 7.5 kW (S7G44, S7G55, S7G75)

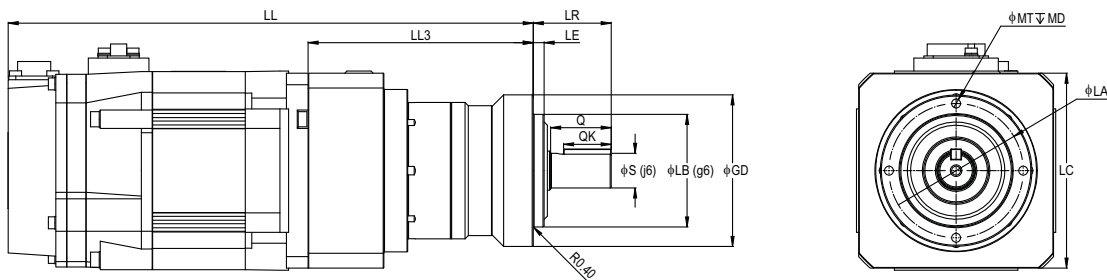

Shaft Detail

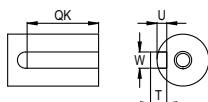

Model S7G	LL	LL3	LR	LE	φS	φLB	φGD	LC	φLA	φMT	MD	Q	QK	KD	W	U	T
4.4 kW Models																	
200 V	44A□ -VL120-03	339	155	70	9	32	90	120	180	M8	16	58	45	0	10	5	8
	44A□ -VL120-05	(387)															
	44A□ -VL205-10	370.5	100	15	55	160	205	M12		22	82	65					
	44A□ -VL205-25	(418.5)															
44A□ -VL235-50	415	231	126	18	75	180	235	M16	28	105	85	20	7.5	12			
5.5 kW Models																	
200 V	55A□ -VL155-03	429	208	97	12	40	120	155	180	M10	20	82	65	0	12	5	8
	55A□ -VL155-05	(473)															
	55A□ -VL205-10	443.5	100	15	55	160	205	M12		22	105	85					
	55A□ -VL205-25	(487.5)															
55A□ -VL235-50	488	267	126	18	75	180	235	M16	28	105	85	20	7.5	12			
7.5 kW Models																	
200 V	75A□ -VL155-03	475	208	97	12	40	120	155	180	M10	20	82	65	0	12	5	8
	75A□ -VL155-05	(519)															
	75A□ -VL205-10	489.5	100	15	55	160	205	M12		22	105	85					
	75A□ -VL205-25	(533.5)															
75A□ -VL235-50	544	277	126	18	75	180	235	M16	28	105	85	20	7.5	12			

Note: The values in parentheses are for Servo Motors with Holding Brakes. 7.0kW motors not available with brake.

## Shaft End Specifications

◆ SGM7G-□□□□□□□□

Code	Specification
2	Straight without key
6	Straight with key and tap for one location (Key slot is JIS B1301-1996 fastening type.)
K	Straight with key and tap with same shaft diameter as Sigma-5 equivalent (for models 03, 09, and 13)

Shaft End Details	Servo Motor Model SGM7G-											
	03	05	09	13	20	30	44	55	75	1A	1E	
Code: 2 (Straight without Key)												
	LR	40	40	58	58	58	79	79	113	113	116	116
	Q	30	30	40	40	40	76	76	110	110	110	110
	S	16 <sup>0</sup> <sub>-0.011</sub>	16 <sup>0</sup> <sub>-0.011</sub>	24 <sup>0</sup> <sub>-0.013</sub>	24 <sup>0</sup> <sub>-0.013</sub>	24 <sup>0</sup> <sub>-0.013</sub>	35 <sup>+0.01</sup> <sub>0</sub>	35 <sup>+0.01</sup> <sub>0</sub>	42 <sup>0</sup> <sub>-0.016</sub>	42 <sup>0</sup> <sub>-0.016</sub>	42 <sup>0</sup> <sub>-0.016</sub>	55 <sup>+0.030</sup> <sub>+0.011</sub>
Code: 6 or K (Straight with Key and Tap)												
	LR	40	40	58	58	58	79	79	113	113	116	116
	Q	30	30	40	40	40	76	76	110	110	110	110
	QK	20	20	25	25	25	60	60	90	90	90	90
	S (Code 6)	16 <sup>0</sup> <sub>-0.011</sub>	16 <sup>0</sup> <sub>-0.011</sub>	24 <sup>0</sup> <sub>-0.013</sub>	24 <sup>0</sup> <sub>-0.013</sub>	24 <sup>0</sup> <sub>-0.013</sub>	35 <sup>+0.01</sup> <sub>0</sub>	35 <sup>+0.01</sup> <sub>0</sub>	42 <sup>0</sup> <sub>-0.016</sub>	42 <sup>0</sup> <sub>-0.016</sub>	42 <sup>0</sup> <sub>-0.016</sub>	55 <sup>+0.030</sup> <sub>+0.011</sub>
	S (Code K)	14 <sup>0</sup> <sub>-0.011</sub>	N/A	19 <sup>0</sup> <sub>-0.013</sub>	22 <sup>0</sup> <sub>-0.013</sub>	N/A	N/A	N/A	N/A	N/A	N/A	N/A
	W	5	5	5	6	8	10	10	12	12	12	16
	T	5	5	5	6	7	8	8	8	8	8	10
	U	3	3	3	3.5	4	5	5	5	5	5	6
	P	M5 screw, Depth: 12					M12 screw, Depth: 25		M16 screw, Depth: 32			M20 screw, Depth: 40

## Selecting Cables

### ◆ Cable Configurations

The cables shown below are required to connect a Servo Motor to a SERVOPACK.

Encoder Cable of 20 m or Less

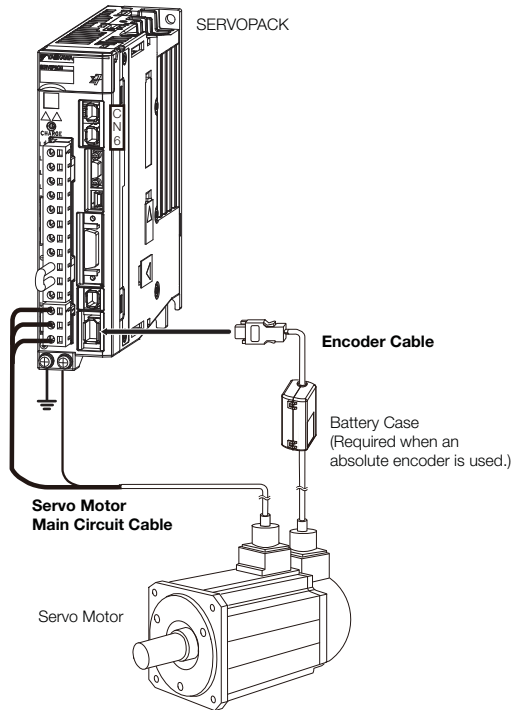

Encoder Cable of 30 m to 50 m (Relay Cable)

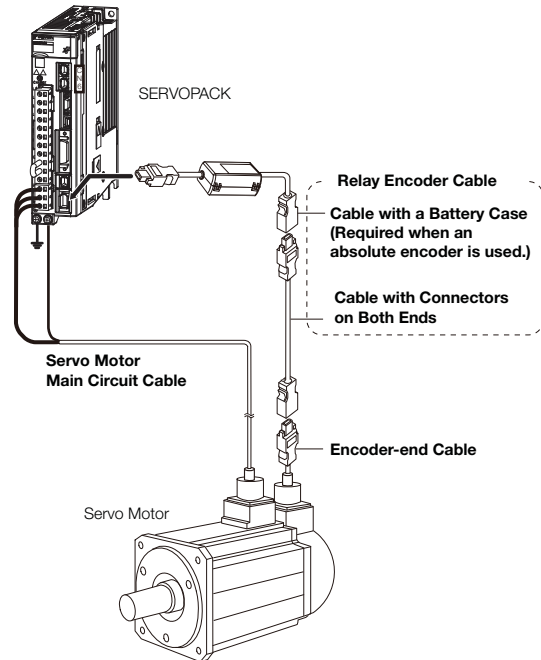

Note: 1. Cables with connectors on both ends that are compliant with an IP67 protective structure and European Safety Standards are not available from Yaskawa for the SGM7G Servo Motors. You must make such a cable yourself. Use the Connectors specified by Yaskawa for these Servo Motors. (These Connectors are compliant with the standards.) Yaskawa does not specify what wiring materials to use.

2. If the cable length exceeds 20 m, be sure to use a Relay Encoder Cable.
3. If you use a Servo Motor Main Circuit Cable that exceeds 20 m, the intermittent duty zone in the torque-motor speed characteristics will become smaller because the voltage drop increases.
4. Refer to the following manual for the following information.
  - Cable dimensional drawings and cable connection specifications
  - Order numbers and specifications of individual connectors for cables
  - Order numbers and specifications for wiring materials

📖 *Σ-7-Series AC Servo Drive Peripheral Device Selection Manual (Manual No.: SIEP S800001 32)*

## Servo Motor Main Circuit Cables

Servo Motor Model	Name	Length (L)	Order Number			Appearance
			Standard Cable	Flexible Cable*	Flexible/Shielded	
SGM7G-03 and -05	Power Cable for Servo Motors without Holding Brakes	3 m	N/A	JZSP-CVM21-03-E	YEA-CVM21-03(A)-E	
		5 m	N/A	JZSP-CVM21-05-E	YEA-CVM21-05(A)-E	
		10 m	N/A	JZSP-CVM21-10-E	YEA-CVM21-10(A)-E	
		15 m	N/A	JZSP-CVM21-15-E	YEA-CVM21-15(A)-E	
		20 m	N/A	JZSP-CVM21-20-E	YEA-CVM21-20(A)-E	
300 W, 450 W	Power Cable for Servo Motors with Holding Brakes	3 m	N/A	JZSP-CVM41-03-E	YEA-CVM41-03(A)-E	
		5 m	N/A	JZSP-CVM41-05-E	YEA-CVM41-03(A)-E	
		10 m	N/A	JZSP-CVM41-10-E	YEA-CVM41-03(A)-E	
		15 m	N/A	JZSP-CVM41-15-E	YEA-CVM41-03(A)-E	
		20 m	N/A	JZSP-CVM41-20-E	YEA-CVM41-03(A)-E	

\* Flexible cables are provided as a standard feature

Servo Motor Model	Name	Length (L)	Order Number			Appearance
			Standard Cable	Flexible Cable	Flexible/Shielded <sup>*2</sup>	
200V SGM7G-850 W, 1.3 kW	Power Cable <sup>*1</sup>	3 m	B1EV-03(A)-E	N/A	B1EP-03(A)-E	
		5 m	B1EV-05(A)-E	N/A	B1EP-05(A)-E	
		10 m	B1EV-10(A)-E	N/A	B1EP-10(A)-E	
		15 m	B1EV-15(A)-E	N/A	B1EP-15(A)-E	
		20 m	B1EV-20(A)-E	N/A	B1EP-20(A)-E	
200V SGM7G-2.0 kW		3 m	B2EV-03(A)-E	N/A	B2EP-03(A)-E	
		5 m	B2EV-05(A)-E	N/A	B2EP-05(A)-E	
		10 m	B2EV-10(A)-E	N/A	B2EP-10(A)-E	
		15 m	B2EV-15(A)-E	N/A	B2EP-15(A)-E	
		20 m	B2EV-20(A)-E	N/A	B2EP-20(A)-E	
200V SGM7G-3.0 kW, to 4.4 kW		3 m	B4EV-03(A)-E	N/A	B4EP-03(A)-E	
		5 m	B4EV-05(A)-E	N/A	B4EP-05(A)-E	
		10 m	B4EV-10(A)-E	N/A	B4EP-10(A)-E	
		15 m	B4EV-15(A)-E	N/A	B4EP-15(A)-E	
		20 m	B4EV-20(A)-E	N/A	B4EP-20(A)-E	
200V SGM7G-5.5 kW, to 7.5 kW		3 m	B6EV-03(A)-E	N/A	B6EP-03(A)-E	
		5 m	B6EV-05(A)-E	N/A	B6EP-05(A)-E	
		10 m	B6EV-10(A)-E	N/A	B6EP-10(A)-E	
		15 m	B6EV-15(A)-E	N/A	B6EP-15(A)-E	
		20 m	B6EV-20(A)-E	N/A	B6EP-20(A)-E	
200V SGM7G-11kW, to 15 kW	3 m	B7EV-03(A)-E	N/A	B7EP-03(A)-E		
	5 m	B7EV-05(A)-E	N/A	B7EP-05(A)-E		
	10 m	B7EV-10(A)-E	N/A	B7EP-10(A)-E		
	15 m	B7EV-15(A)-E	N/A	B7EP-15(A)-E		
	20 m	B7EV-20(A)-E	N/A	B7EP-20(A)-E		

Servo Motor Model	Name	Length (L)	Order Number			Appearance
			Standard Cable	Flexible Cable	Flexible/Shielded <sup>2</sup>	
200V SGM7G-850 W to 15 kW	Holding Brake Cable	3 m	BBEV-03(A)-E	N/A	N/A	
		5 m	BBEV-05(A)-E	N/A	N/A	
		10 m	BBEV-10(A)-E	N/A	N/A	
		15 m	BBEV-15(A)-E	N/A	N/A	
		20 m	BBEV-20(A)-E	N/A	N/A	
		3 m	N/A	N/A	BBEP-03(A)-E	
		5 m	N/A	N/A	BBEP-05(A)-E	
		10 m	N/A	N/A	BBEP-10(A)-E	
		15 m	N/A	N/A	BBEP-15(A)-E	
		20 m	N/A	N/A	BBEP-20(A)-E	

\*1. Servo Motors with holding brakes require a holding brake cable in addition to a power cable.

\*2. The order number for the Main Power Supply Cable is JZSP-UVA101-xx-E (standard cable) or JZSP-UVA121-xx-E (flexible cable). The order number for the Holding Brake Connector Kit is JZSP-CVB9-SMC3-E.

## Encoder Cables of 20 m or Less

Servo Motor Model	Name	Length (L)	Order Number		Appearance	
			Standard Cable	Flexible Cable*		
All SGM7G models	Cables with Connectors on Both Ends (for incremental encoder)	3 m	JZSP-CVP01-03-E	JZSP-CVP11-03-E		
		5 m	JZSP-CVP01-05-E	JZSP-CVP11-05-E		
		10 m	JZSP-CVP01-10-E	JZSP-CVP11-10-E		
		15 m	JZSP-CVP01-15-E	JZSP-CVP11-15-E		
		20 m	JZSP-CVP01-20-E	JZSP-CVP11-20-E		
	Cables with Connectors on Both Ends (for absolute encoder: With Battery Case)	3 m	JZSP-CVP02-03-E	JZSP-CVP12-03-E		
		5 m	JZSP-CVP02-05-E	JZSP-CVP12-05-E		
		10 m	JZSP-CVP02-10-E	JZSP-CVP12-10-E		
		15 m	JZSP-CVP02-15-E	JZSP-CVP12-15-E		
		20 m	JZSP-CVP02-20-E	JZSP-CVP12-20-E		
		3 m	JZSP-CVP06-03-E	JZSP-CVP26-03-E		
		5 m	JZSP-CVP06-05-E	JZSP-CVP26-05-E		
		10 m	JZSP-CVP06-10-E	JZSP-CVP26-10-E		
		15 m	JZSP-CVP06-15-E	JZSP-CVP26-15-E		
		20 m	JZSP-CVP06-20-E	JZSP-CVP26-20-E		
		3 m	JZSP-CVP07-03-E	JZSP-CVP27-03-E		
		5 m	JZSP-CVP07-05-E	JZSP-CVP27-05-E		
		10 m	JZSP-CVP07-10-E	JZSP-CVP27-10-E		
15 m	JZSP-CVP07-15-E	JZSP-CVP27-15-E				
20 m	JZSP-CVP07-20-E	JZSP-CVP27-20-E				

\* Use Flexible Cables for moving parts of machines, such as robots.

NOTE: Shaded items are non-stock items.

## Relay Encoder Cables of 30 m to 50 m

Servo Motor Model	Name	Length (L)	Order Number for Standard Cable	Appearance
All SGM7G models	Encoder-end Cable (for incremental or absolute encoder)	0.3 m	JZSP-CVP01-E	
			JZSP-CVP02-E	
	Cables with Connectors on Both Ends (for incremental or absolute encoder)	30 m	JZSP-UCMP00-30-E	
		40 m	JZSP-UCMP00-40-E	
		50 m	JZSP-UCMP00-50-E	
	Cable with a Battery Case (Required when an absolute encoder is used.)*	0.3 m	JZSP-CSP12-E	<p>Battery Case (battery included)</p>

\* This Cable is not required if a battery is connected to the host controller.



## Connector Specifications

### ◆ SGM7G-03 and -05 without Holding Brakes

- Encoder Connector Specifications (24-bit Encoder)

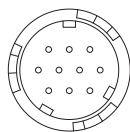

Receptacle: CM10-R10P-D  
Applicable plug: Not provided by Yaskawa.  
Plug: CM10-AP10S-□D for Right-angle Plug  
CM10-SP10S-□D for Straight Plug  
(□depends on the applicable cable size.)  
Manufacturer: DDK Ltd.

- Servo Motor Connector Specifications

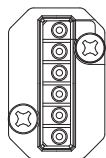

Manufacturer: Japan Aviation Electronics Industry, Ltd.

### ◆ SGM7G-09 to -1E without Holding Brakes

- Encoder Connector Specifications (24-bit Encoder)

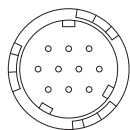

Receptacle: CM10-R10P-D  
Applicable plug: Not provided by Yaskawa.  
Plug: CM10-AP10S-□D for Right-angle Plug  
CM10-SP10S-□D for Straight Plug  
(□depends on the applicable cable size.)  
Manufacturer: DDK Ltd.

- Servo Motor Connector Specifications

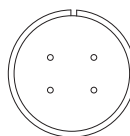

Manufacturer: DDK Ltd.

◆ SGM7G-03 and -05 with Holding Brakes

- Encoder Connector Specifications (24-bit Encoder)

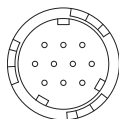

Receptacle: CM10-R10P-D  
Applicable plug: Not provided by Yaskawa.  
Plug: CM10-AP10S-□D for Right-angle Plug  
CM10-SP10S-□D for Straight Plug  
(□depends on the applicable cable size.)  
Manufacturer: DDK Ltd.

- Servo Motor Connector Specifications

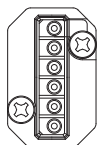

Manufacturer: Japan Aviation Electronics Industry, Ltd.

◆ SGM7G-09 to -1E with Holding Brakes

- Encoder Connector Specifications (24-bit Encoder)

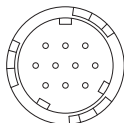

Receptacle: CM10-R10P-D  
Applicable plug: Not provided by Yaskawa.  
Plug: CM10-AP10S-□D for Right-angle Plug  
CM10-SP10S-□D for Straight Plug  
(□depends on the applicable cable size.)  
Manufacturer: DDK Ltd.

- Servo Motor Connector Specifications

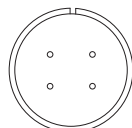

Manufacturer: DDK Ltd.

- Brake Connector Specifications

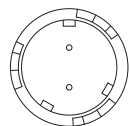

Receptacle: CM10-R2P-D  
Applicable plug: Not provided by Yaskawa.  
Plug: CM10-AP2S-□D for Right-angle Plug  
CM10-SP2S-□D for Straight Plug  
(□depends on the applicable cable size.)  
Manufacturer: DDK Ltd.

# Direct Drive Servo Motors

---

SGM7F (With Core, Inner Rotor) ..... 136

SGMCS (Small Capacity, Coreless or Medium  
Capacity, with Core) ..... 152

# SGM7F (With Core, Inner Rotor)

## Model Designations

SGM7F - 02 A 7 A 1 1

1st+2nd digits   3rd digit   4th digit   5th digit   6th digit   7th digit

Direct Drive Servomotors: SGM7F

**1st+2nd digits** Rated Output

Code	Specification
02	2.00 N·m
04	4.00 N·m
05	5.00 N·m
07	7.00 N·m
08	8.00 N·m
10	10.0 N·m
14	14.0 N·m
16	16.0 N·m
17	17.0 N·m
25	25.0 N·m
35	35.0 N·m

Note: 02, 05, and 07 models yet to be released

**3rd digit** Servomotor Outer Diameter

Code	Specification
A	100-mm dia.
B	135-mm dia.
C	175-mm dia.
D	230-mm dia.
M	280-mm dia.
N	360-mm dia.

**4th digit** Serial Encoder

Code	Specification
7	24-bit multiturn absolute encoder*
F	24-bit incremental encoder*

\* Both multiturn absolute encoder and incremental encoder can be used as a single-turn absolute encoder by setting parameters.

**5th digit** Design Revision Order

M: Standard

**6th digit** Flange

Code	Mounting	Servomotor Outer Diameter Code (3rd Digit)			
		A	B	C	D
1	Non-load side	✓	✓	✓	✓
	Load side	-	-	-	-
3	Non-load side	-	-	-	-
4	Non-load side (with cable on side)	✓	✓	✓	✓

✓ : Applicable models.

**7th digit** Options

Code	Specification
1	Without options
2	High machine precision (runout at end of shaft and runout of shaft surface: 0.01 mm)

Note: Shaded Serial Encoder and Options are non-stock

Note: 1. Direct Drive Servomotors are not available with holding brakes.

2. This information is provided to explain model numbers. It is not meant to imply that models are available for all combinations of codes.

### ◆ Manufactured Models

Rated Torque N·m	Servomotor Outer Diameter			
	A (100-mm dia.)	B (135-mm dia.)	C (175-mm dia.)	D (230-mm dia.)
2.00	SGM7F-02A	-	-	-
4.00	-	SGM7F-04B	-	-
5.00	SGM7F-05A	-	-	-
7.00	SGM7F-07A	-	-	-
8.00	-	-	SGM7F-08C	-
10.0	-	SGM7F-10B	-	-
14.0	-	SGM7F-14B	-	-
16.0	-	-	-	SGM7F-16D
17.0	-	-	SGM7F-17C	-
25.0	-	-	SGM7F-25C	-
35.0	-	-	-	SGM7F-35D
45.0	-	-	-	-
80.0	-	-	-	-
110	-	-	-	-
150	-	-	-	-
200	-	-	-	-

Note: The above table shows combinations of the rated torque and outer diameter. The fourth through seventh digits have been omitted.

## Specifications and Ratings: Small Capacity

### Specifications

Voltage		200 V										
Model SGM7F-		02A	05A	07A	04B	10B	14B	08C	17C	25C	16D	35D
Time Rating		Continuous										
Thermal Class		A										
Insulation Resistance		500 VDC, 10 MΩmin.										
Withstand Voltage		1,500 VAC for 1 minute										
Excitation		Permanent magnet										
Mounting		Flange-mounted										
Drive Method		Direct drive										
Rotation Direction		Counterclockwise (CCW) for forward reference when viewed from the load side										
Vibration Class*1		V15										
Absolute Accuracy		±15 s										
Repeatability		±1.3 s										
Protective Structure*2		Totally enclosed, self-cooled, IP42 (The protective structure is IP40 for CE Marking.)										
Environmental Conditions	Surrounding Air Temperature	0°C to 40°C (with no freezing)										
	Surrounding Air Humidity	20% to 80% relative humidity (with no condensation)										
	Installation Site	<ul style="list-style-type: none"> <li>• Must be indoors and free of corrosive and explosive gases.</li> <li>• Must be well-ventilated and free of dust and moisture.</li> <li>• Must facilitate inspection and cleaning.</li> <li>• Must have an altitude of 1,000 m or less.</li> <li>• Must be free of strong magnetic fields.</li> </ul>										
	Storage Environment	Store the Servomotor in the following environment if you store it with the power cable disconnected. Storage Temperature: -20°C to 60°C (with no freezing) Storage Humidity: 20% to 80% relative humidity (with no condensation)										
Mechanical Tolerances*3	Runout of Output Shaft Surface	mm	0.02 (0.01 for high machine precision option)									
	Runout at End of Output Shaft	mm	0.04 (0.01 for high machine precision option)									
	Parallelism between Mounting Surface and Output Shaft Surface	mm	0.07									
	Concentricity between Output Shaft and Flange Outer Diameter	mm	0.07									
Shock Resistance*4	Impact Acceleration Rate at Flange	490 m/s <sup>2</sup>										
	Number of Impacts	2 times										
Vibration Resistance*4	Vibration Acceleration Rate at Flange	49 m/s <sup>2</sup>										
Applicable SERVOPACKs		SGD7S-	2R8A, 2R1F	2R8A, 2R8F		5R5A	2R8A, 2R8F	5R5A	7R6A	5R5A	7R6A*5, 120A	
		SGD7W-SGD7C-	2R8A		2R8A		7R6A*5					

- \*1. A vibration class of V15 indicates a vibration amplitude of 15 μm maximum on the Servomotor without a load at the rated motor speed.  
 \*2. The hollow hole section, motor mounting surface, output shaft surface, and gap around the rotating part of the shaft are excluded. Protective structure specifications apply only when the special cable is used.  
 \*3. Refer to the following figure for the relevant locations on the Servomotor. Refer to the dimensional drawings of the individual Servomotors for more information on tolerances.

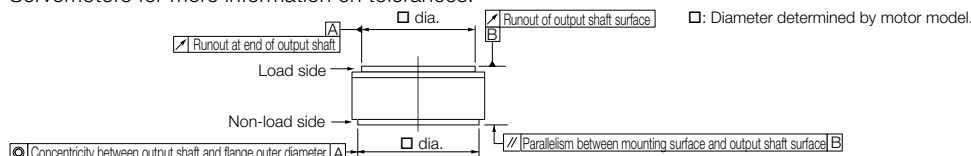

- \*4. The given values are for when the Servomotor shaft is mounted horizontally and shock or vibration is applied in the directions shown in the following figures. The strength of the vibration that the Servomotor can withstand depends on the application. Check the vibration acceleration rate.

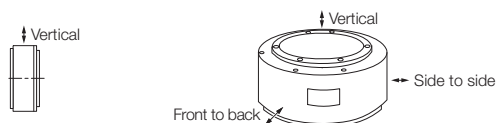

Shock Applied to the Servomotor

Vibration Applied to the Servomotor

- \*5. Use derated values for this combination. Refer to the following section for information on derating values.

Ratings (page 138)

## Ratings

Voltage		200 V										
Model SGM7F-		02A	05A	07A	04B	10B	14B	08C	17C	25C	16D	35D
Rated Output* <sup>1</sup>	W	63	157	220	126	314	440	251	534	785	503	1100 1000 * <sup>5</sup>
Rated Torque* <sup>1, *2</sup>	N·m	2.00	5.00	7.00	4.00	10.0	14.0	8.00	17.0	25.0	16.0	35.0
Instantaneous Maximum Torque* <sup>1</sup>	N·m	6.00	15.0	21.0	12.0	30.0	42.0	24.0	51.0	75.0	48.0	105
Stall Torque* <sup>1</sup>	N·m	2.00	5.00	7.00	4.00	10.0	14.0	8.00	17.0	25.0	16.0	35.0
Rated Current* <sup>1</sup>	Arms	1.7	1.8	2.1	2.0	2.8	4.6	2.4	4.5		5.0	
Instantaneous Maximum Current* <sup>1</sup>	Arms	5.1	5.4	6.3	6.4	8.9	14.1	8.6	14.7	13.9	16.9	16.0
Rated Motor Speed* <sup>1</sup>	min <sup>-1</sup>	300			300			300				300 270* <sup>5</sup>
Maximum Motor Speed* <sup>1</sup>	min <sup>-1</sup>	600			600			600		500	600	400
Torque Constant	N·m/Arms	1.28	3.01	3.64	2.21	3.81	3.27	3.52	4.04	6.04	3.35	7.33
Motor Moment of Inertia	×10 <sup>-4</sup> kg·m <sup>2</sup>	8.04	14.5	19.3	16.2	25.2	36.9	56.5	78.5	111	178	276
Rated Power Rate* <sup>1</sup>	kW/s	4.98	17.2	25.4	9.88	39.7	53.1	11.3	36.8	56.3	14.4	44.4
Rated Angular Acceleration Rate* <sup>1</sup>	rad/s <sup>2</sup>	2490	3450	3630	2470	3970	3790	1420	2170	2250	899	1270
Heat Sink Size	mm	300 × 300 × 12			350 × 350 × 12			450 × 450 × 12				550 × 550 × 12
Allowable Load Moment of Inertia (Motor Moment of Inertia Ratio)		25 times	35 times	35 times	25 times	40 times	45 times	15 times	25 times	25 times	10 times	15 times
	With External Regenerative Resistor and External Dynamic Brake Resistor* <sup>3</sup>	25 times	35 times	35 times	25 times	40 times	45 times	15 times	25 times	25 times	10 times	15 times
Allowable Load* <sup>4</sup>	Allowable Thrust Load	N	22	24	26	1500			3300			4000
	Allowable Moment Load	N·m	1100	1100	1100	45	55	65	92	98	110	210

\*1. These values are for operation in combination with a SERVOPACK when the temperature of the armature winding is 100°C. The values for other items are at 20°C. These are typical values.

\*2. The rated torques are the continuous allowable torque values at a surrounding air temperature of 40°C with a steel heat sink of the dimensions given in the table.

\*3. To externally connect dynamic brake resistor, select hardware option specification 020 for the SERVOPACK. However, you cannot externally connect dynamic brake resistor if you use the following SERVOPACKs (maximum applicable motor capacity: 400 W).

- SGD7S-R70□□□A020 to -2R8□□□A020
- SGD7W-1R6A20A020 to -2R8A20A020
- SGD7C-1R6AMAA020 to -2R8AMAA020

\*4. The thrust loads and moment loads that are applied while a Servomotor is operating are roughly classified into the following patterns. Design the machine so that the thrust loads or moment loads will not exceed the values given in the table.

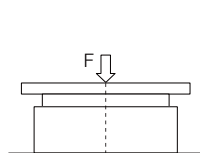

Where F is the external force,  
 Thrust load = F + Load mass  
 Moment load = 0

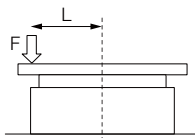

Where F is the external force,  
 Thrust load = F + Load mass  
 Moment load = F × L

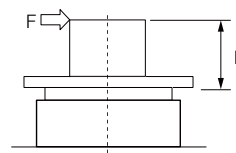

Where F is the external force,  
 Thrust load = Load mass  
 Moment load = F × L

\*5. If you use an SGD7S-7R6A SERVOPACK and SGM7F-35D Servomotor together, use this value (a derated value).

Note: For the bearings used in these Servomotors, the loss depends on the bearing temperature. The amount of heat loss is higher at low temperatures.

## Torque-Motor Speed Characteristics

A : Continuous duty zone — (solid lines): With three-phase 200-V or single-phase 230-V input  
B : Intermittent duty zone - - - (dotted lines): With single-phase 200-V input  
 - · - (dashed-dotted lines): With single-phase 100-V input

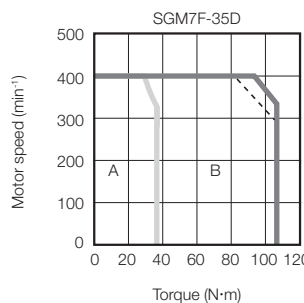
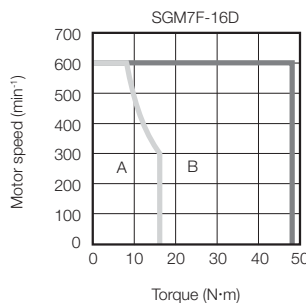
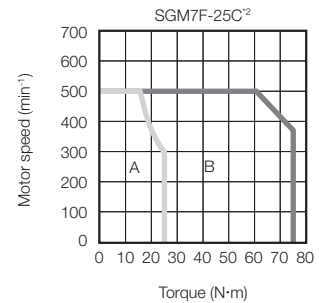
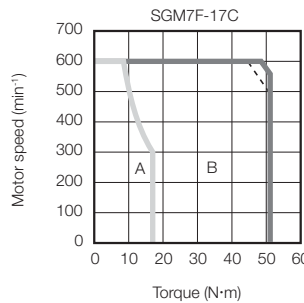
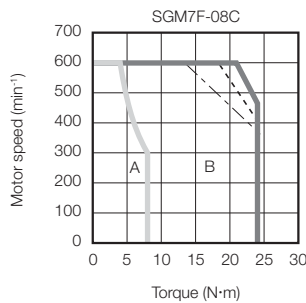
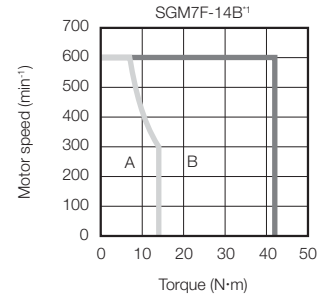
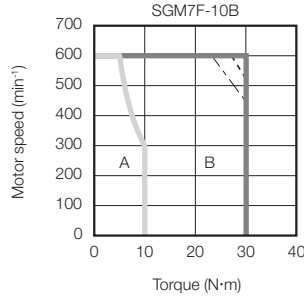
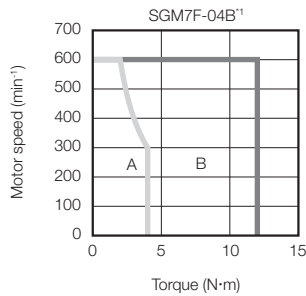
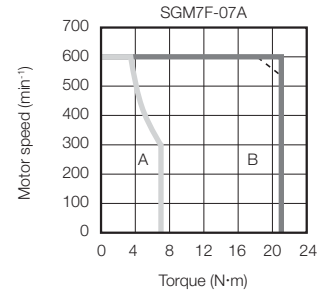
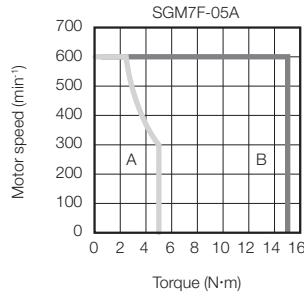
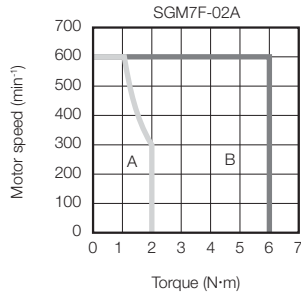

\*1. The characteristics are the same for three-phase 200 V, single-phase 200 V, and single-phase 100 V.

\*2. Contact your Yaskawa representative for information on the SGM7F-25C.

Note: 1. These values (typical values) are for operation in combination with a SERVOPACK when the temperature of the armature winding is 100°C.

2. The characteristics in the intermittent duty zone depend on the power supply voltage.

3. If you use a Servomotor Main Circuit Cable that exceeds 20 m, the intermittent duty zone in the torque-motor speed characteristics will become smaller because the voltage drop increases.

## Servomotor Overload Protection Characteristics

The overload detection level is set for hot start conditions with a Servomotor surrounding air temperature of 40°C.

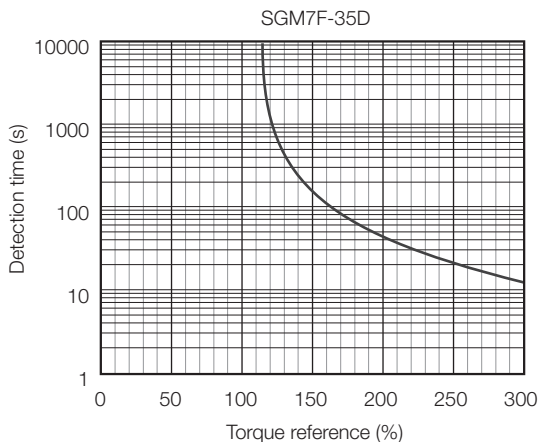
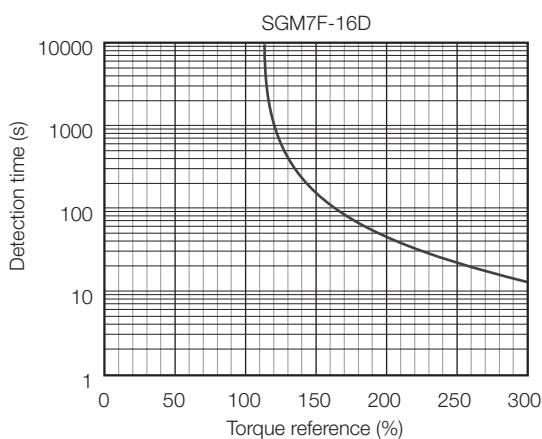
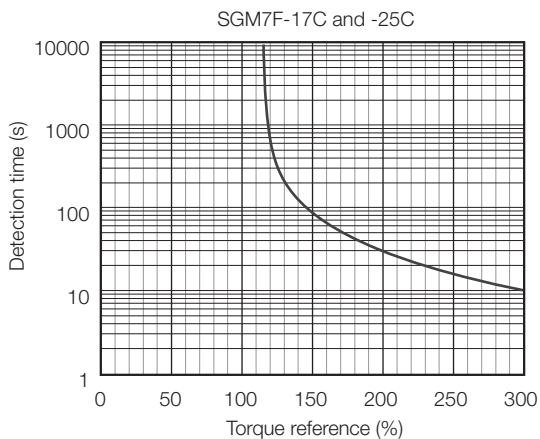
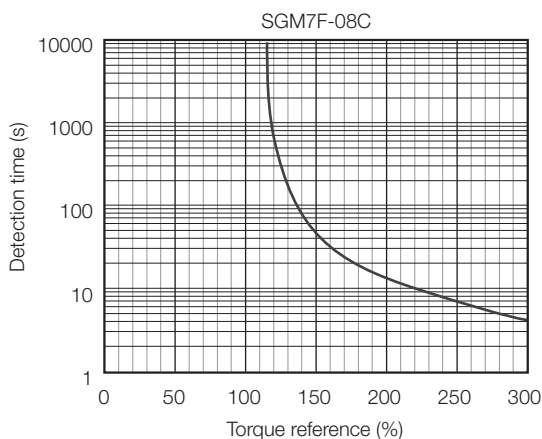
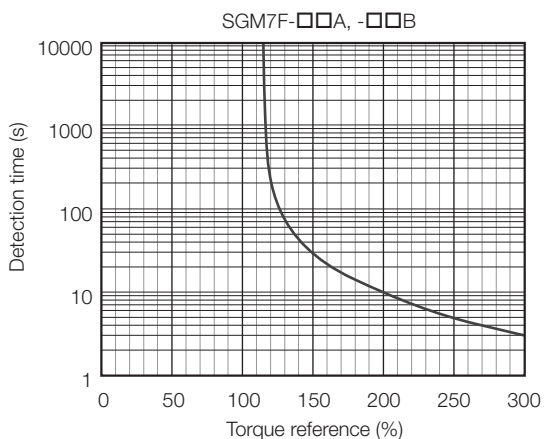

Note: The above overload protection characteristics do not mean that you can perform continuous duty operation with an output of 100% or higher. Use the Servomotor so that the effective torque remains within the continuous duty zone given in Torque-Motor Speed Characteristics on page 139.



## Allowable Load Moment of Inertia

The allowable load moments of inertia (motor moment of inertia ratios) for the Servomotors are given in the Ratings (page 138). The values are determined by the regenerative energy processing capacity of the SERVOPACK and are also affected by the drive conditions of the Servomotor. Perform the required Steps for each of the following cases.

Use the SigmaSize+ AC Servo Drive Capacity Selection Program to check the driving conditions. Contact your Yaskawa representative for information on this program.

### ◆ Exceeding the Allowable Load Moment of Inertia

Use one of the following measures to adjust the load moment of inertia to within the allowable value.

- Reduce the torque limit.
- Reduce the deceleration rate.
- Reduce the maximum motor speed.

If the above steps is not possible, install an external regenerative resistor.

#### Information

An Overvoltage Alarm (A.400) is likely to occur during deceleration if the load moment of inertia exceeds the allowable load moment of inertia. SERVOPACKs with a built-in regenerative resistor may generate a Regenerative Overload Alarm (A.320). Refer to External Regenerative Resistors (page 385) for the regenerative power (W) that can be processed by the SERVOPACKs.

Install an External Regenerative Resistor when the built-in regenerative resistor cannot process all of the regenerative power.

### ◆ SERVOPACKs without Built-in Regenerative Resistors

The following graph shows the allowable load moment of inertia scaling factor of the motor speed (reference values for deceleration operation at or above the rated torque). Application is possible without an external regenerative resistor within the allowable value. However, an External Regenerative Resistor is required in the shaded areas of the graphs.

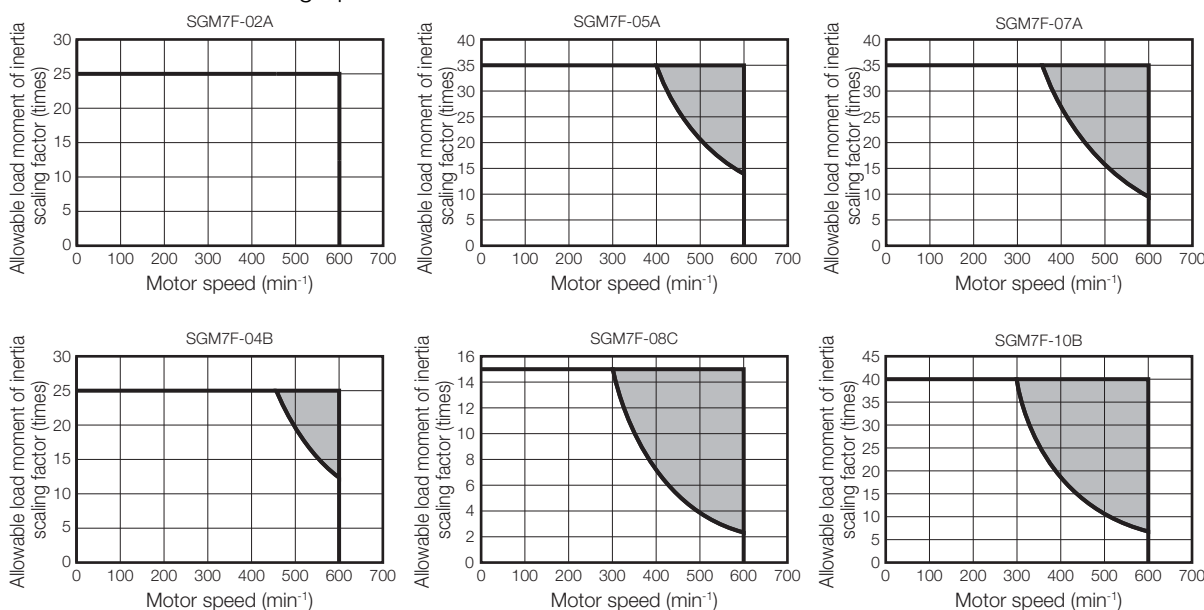

Note: Applicable SERVOPACK models: SGD7S-2R8A and -2R8F

### ◆ When an External Regenerative Resistor Is Required

Install the External Regenerative Resistor. Refer to the following section for the recommended products.

**External Regenerative Resistors (page 385)**

## External Dimensions

### ◆ SGM7F-□□A

#### • Flange Specification 1

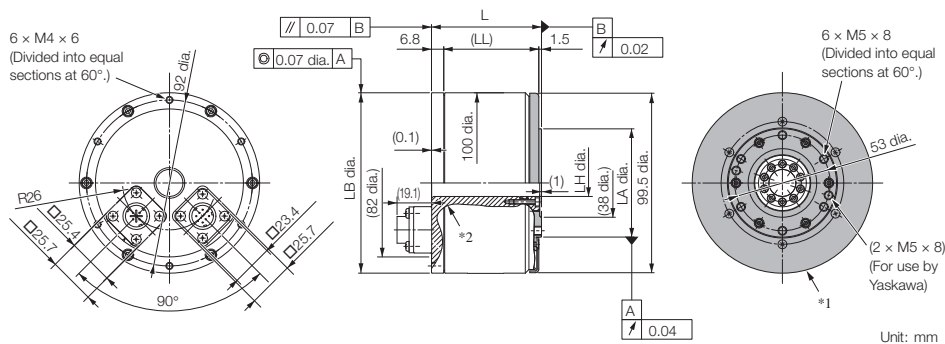

- \*1. The shaded section indicates the rotating parts.  
\*2. The hatched section indicates the non-rotating parts.  
Note: Values in parentheses are reference dimensions.

Model SGM7F-	L	(LL)	LB	LH	LA	Approx. Mass [kg]
02A□□A11	61	(52.7)	100 <sup>0</sup> <sub>-0.035</sub>	15 <sup>+0.4</sup> <sub>0</sub>	60 <sup>0</sup> <sub>-0.030</sub>	2.5
05A□□A11	96	(87.7)	100 <sup>0</sup> <sub>-0.035</sub>	15 <sup>+0.4</sup> <sub>0</sub>	60 <sup>0</sup> <sub>-0.030</sub>	5.0
07A□□A11	122	(113.7)	100 <sup>0</sup> <sub>-0.035</sub>	15 <sup>+0.4</sup> <sub>0</sub>	60 <sup>0</sup> <sub>-0.030</sub>	6.5

#### • Flange Specification 4

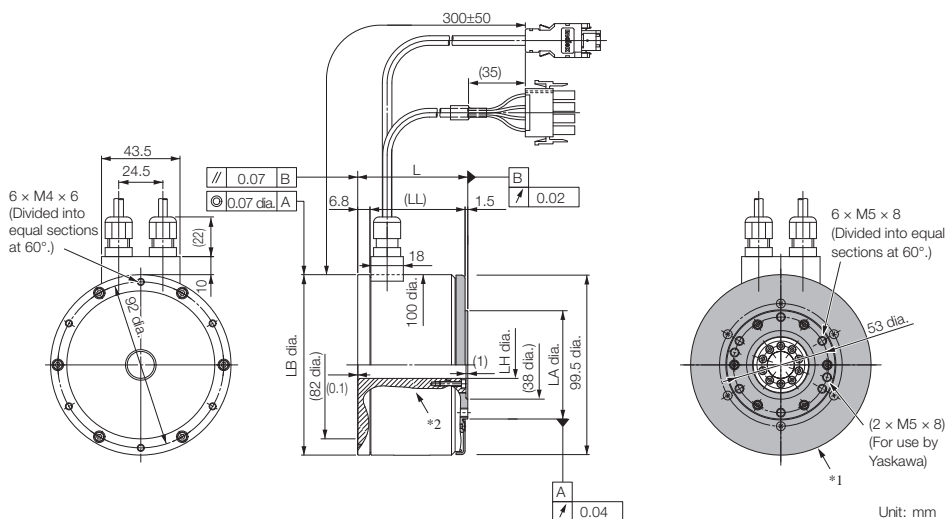

- \*1. The shaded section indicates the rotating parts.  
\*2. The hatched section indicates the non-rotating parts.  
Note: Values in parentheses are reference dimensions.

Model SGM7F-	L	(LL)	LB	LH	LA	Approx. Mass [kg]
02A□□A41	61	(52.7)	100 <sup>0</sup> <sub>-0.035</sub>	15 <sup>+0.4</sup> <sub>0</sub>	60 <sup>0</sup> <sub>-0.030</sub>	2.5
05A□□A41	96	(87.7)	100 <sup>0</sup> <sub>-0.035</sub>	15 <sup>+0.4</sup> <sub>0</sub>	60 <sup>0</sup> <sub>-0.030</sub>	5.0
07A□□A41	122	(113.7)	100 <sup>0</sup> <sub>-0.035</sub>	15 <sup>+0.4</sup> <sub>0</sub>	60 <sup>0</sup> <sub>-0.030</sub>	6.5

Refer to the following section for information on connectors.

**Connector Specifications (page 146)**

◆ SGM7F-□□B

• Flange Specification 1

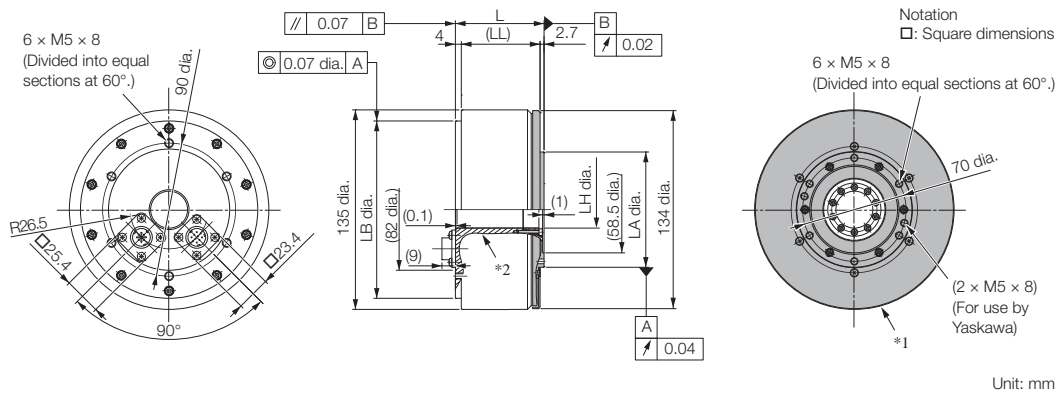

- \*1. The shaded section indicates the rotating parts.
  - \*2. The hatched section indicates the non-rotating parts.
- Note: Values in parentheses are reference dimensions.

Model SGM7F-	L	(LL)	LB	LH	LA	Approx. Mass [kg]
04B□A11	60	53.3	120 <sup>0</sup> <sub>-0.035</sub>	25 <sup>+0.3</sup> <sub>+0.1</sub>	78 <sup>0</sup> <sub>-0.030</sub>	5.0
10B□A11	85	78.3	120 <sup>0</sup> <sub>-0.035</sub>	25 <sup>+0.3</sup> <sub>+0.1</sub>	78 <sup>0</sup> <sub>-0.030</sub>	6.5
14B□A11	115	108.3	120 <sup>0</sup> <sub>-0.035</sub>	25 <sup>+0.3</sup> <sub>+0.1</sub>	78 <sup>0</sup> <sub>-0.030</sub>	9.0

• Flange Specification 4

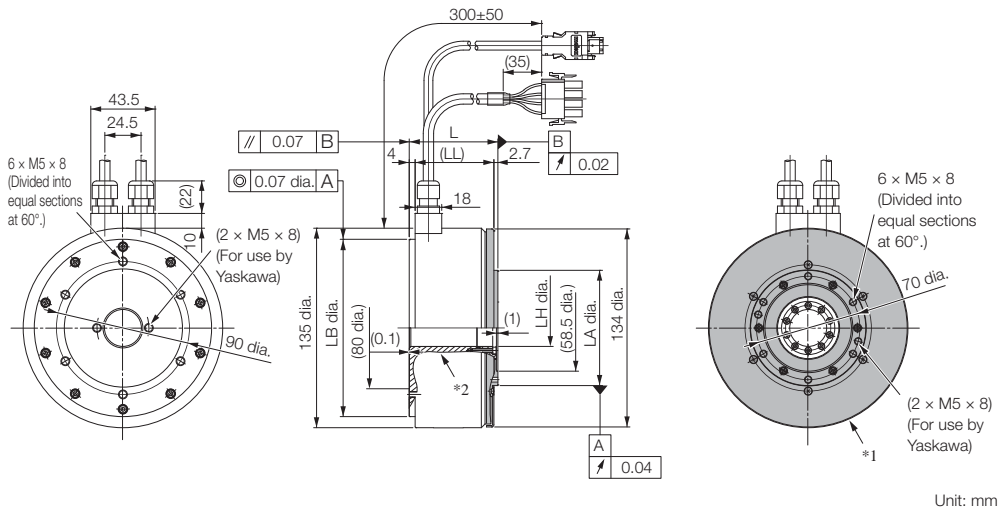

- \*1. The shaded section indicates the rotating parts.
  - \*2. The hatched section indicates the non-rotating parts.
- Note: Values in parentheses are reference dimensions.

Model SGM7F-	L	(LL)	LB	LH	LA	Approx. Mass [kg]
04B□A41	60	53.3	120 <sup>0</sup> <sub>-0.035</sub>	25 <sup>+0.3</sup> <sub>+0.1</sub>	78 <sup>0</sup> <sub>-0.030</sub>	5.0
10B□A41	85	78.3	120 <sup>0</sup> <sub>-0.035</sub>	25 <sup>+0.3</sup> <sub>+0.1</sub>	78 <sup>0</sup> <sub>-0.030</sub>	6.5
14B□A41	115	108.3	120 <sup>0</sup> <sub>-0.035</sub>	25 <sup>+0.3</sup> <sub>+0.1</sub>	78 <sup>0</sup> <sub>-0.030</sub>	9.0

Refer to the following section for information on connectors.

🔌 Connector Specifications (page 146)

◆ **SGM7F-□□C**

• **Flange Specification 1**

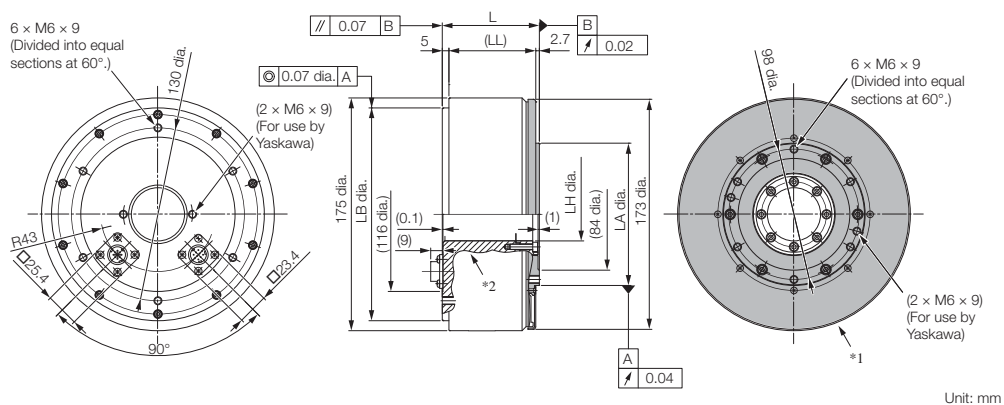

\*1. The shaded section indicates the rotating parts.  
 \*2. The hatched section indicates the non-rotating parts.  
 Note: Values in parentheses are reference dimensions.

Model SGM7F-	L	(LL)	LB	LH	LA	Approx. Mass [kg]
08C□A11	73	65.3	160 <sup>0</sup> <sub>-0.040</sub>	40 <sup>+0.3</sup> <sub>+0.1</sub>	107 <sup>0</sup> <sub>-0.035</sub>	9.0
17C□A11	87	79.3	160 <sup>0</sup> <sub>-0.040</sub>	40 <sup>+0.3</sup> <sub>+0.1</sub>	107 <sup>0</sup> <sub>-0.035</sub>	11.0
25C□A11	117	109.3	160 <sup>0</sup> <sub>-0.040</sub>	40 <sup>+0.3</sup> <sub>+0.1</sub>	107 <sup>0</sup> <sub>-0.035</sub>	15.0

• **Flange Specification 4**

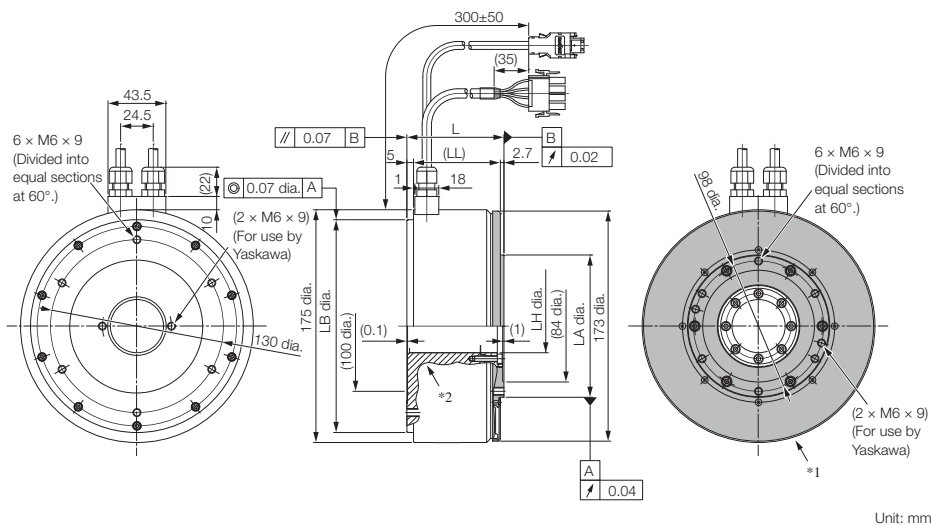

\*1. The shaded section indicates the rotating parts.  
 \*2. The hatched section indicates the non-rotating parts.  
 Note: Values in parentheses are reference dimensions.

Model SGM7F-	L	(LL)	LB	LH	LA	Approx. Mass [kg]
08C□A41	73	65.3	160 <sup>0</sup> <sub>-0.040</sub>	40 <sup>+0.3</sup> <sub>+0.1</sub>	107 <sup>0</sup> <sub>-0.035</sub>	9.0
17C□A41	87	79.3	160 <sup>0</sup> <sub>-0.040</sub>	40 <sup>+0.3</sup> <sub>+0.1</sub>	107 <sup>0</sup> <sub>-0.035</sub>	11.0
25C□A41	117	109.3	160 <sup>0</sup> <sub>-0.040</sub>	40 <sup>+0.3</sup> <sub>+0.1</sub>	107 <sup>0</sup> <sub>-0.035</sub>	15.0

Refer to the following section for information on connectors.

🔌 **Connector Specifications (page 146)**

◆ SGM7F-□□D

• Flange Specification 1

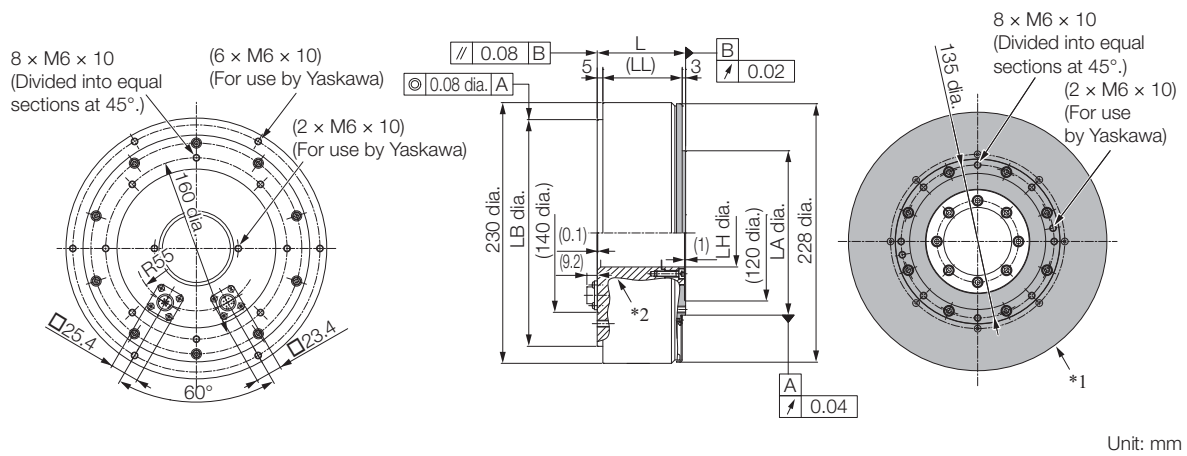

\*1. The shaded section indicates the rotating parts.  
\*2. The hatched section indicates the non-rotating parts.  
Note: Values in parentheses are reference dimensions.

Model SGM7F-	L	(LL)	LB	LH	LA	Approx. Mass [kg]
16D□A11	78	70	200 <sup>0</sup> <sub>-0.046</sub>	60 <sup>+0.4</sup> <sub>0</sub>	145 <sup>0</sup> <sub>-0.040</sub>	16.0
35D□A11	107	99	200 <sup>0</sup> <sub>-0.046</sub>	60 <sup>+0.4</sup> <sub>0</sub>	145 <sup>0</sup> <sub>-0.040</sub>	25.0

• Flange Specification 4

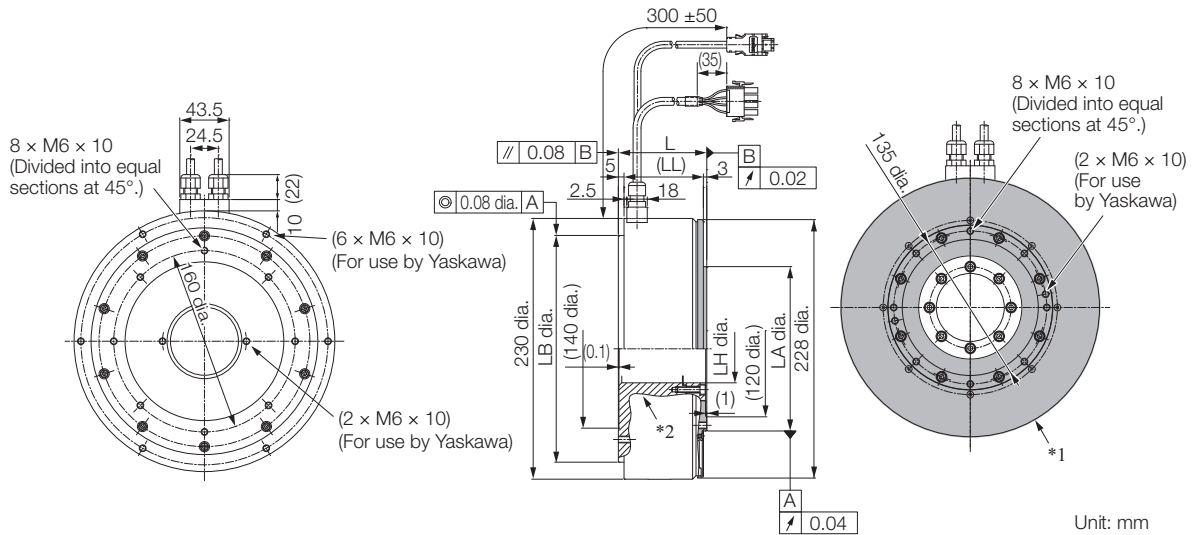

\*1. The shaded section indicates the rotating parts.  
\*2. The hatched section indicates the non-rotating parts.  
Note: Values in parentheses are reference dimensions.

Model SGM7F-	L	(LL)	LB	LH	LA	Approx. Mass [kg]
16D□A41	78	70	200 <sup>0</sup> <sub>-0.046</sub>	60 <sup>+0.4</sup> <sub>0</sub>	145 <sup>0</sup> <sub>-0.040</sub>	16.0
35D□A41	107	99	200 <sup>0</sup> <sub>-0.046</sub>	60 <sup>+0.4</sup> <sub>0</sub>	145 <sup>0</sup> <sub>-0.040</sub>	25.0

Refer to the following section for information on connectors.

👉 Connector Specifications (page 146)

## Connector Specifications

### ◆ SGM7F-□□A, -□□B, -□□C, or -□□D: Flange Specification 1

#### • Servomotor Connector

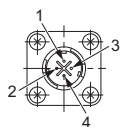

1	Phase U
2	Phase V
3	Phase W
4	FG (frame ground)

**Model:** JN1AS04MK2R  
Manufacturer: Japan Aviation Electronics Industry, Ltd.

**Mating connector:** JN1DS04FK1  
(Not provided by Yaskawa.)

#### • Encoder Connector

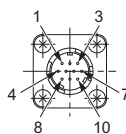

1	PS
2	/PS
3	-
4	PG5V
5*	BATO
6	-
7	FG (frame ground)
8*	BAT
9	PG0V
10	-

\* Only absolute-value models with multiturn data.

**Model:** JN1AS10ML1-R  
Manufacturer: Japan Aviation Electronics Industry, Ltd.

**Mating connector:** JN1DS10SL1  
(Not provided by Yaskawa.)

### ◆ SGM7F-□□A, -□□B, -□□C, or -□□D: Flange Specification 4

#### • Servomotor Connector



1	Phase U	Red
2	Phase V	White
3	Phase W	Blue
4	FG (frame ground)	Green (yellow)

#### Models

- Plug: 350779-1
  - Pins: 350561-3 or 350690-3 (No. 1 to 3)
  - Ground pin: 350654-1 or 350669-1 (No. 4)
- Manufacturer: Tyco Electronics Japan G.K.

#### Mating Connector

- Cap: 350780-1
- Socket: 350570-3 or 350689-3

#### • Encoder Connector

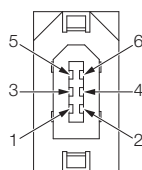

1	PG5V
2	PG0V
3*	BAT
4*	BATO
5	PS
6	/PS
<b>Connector case</b>	FG (frame ground)

\* Only absolute-value models with multiturn data.

**Model:** 55102-0600  
Manufacturer: Molex Japan LLC

**Mating connector:** 54280-0609

## Selecting Cables

### ◆ Cable Configurations

The cables shown below are required to connect a Servomotor to a SERVOPACK.

Encoder Cable of 20 m or Less

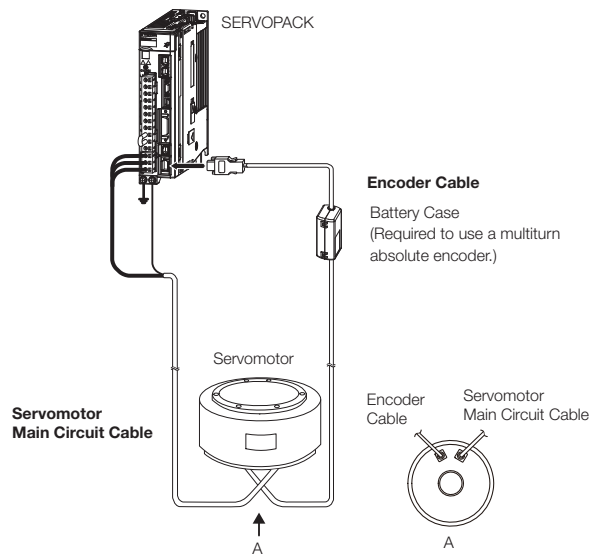

Encoder Cable of 30 m to 50 m (Relay Cable)

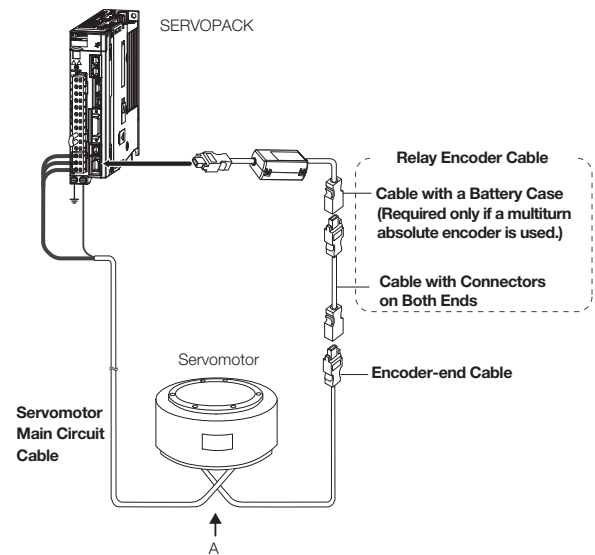

Note: 1. If the Encoder Cable length exceeds 20 m, be sure to use a Relay Encoder Cable.

2. If you use a Servomotor Main Circuit Cable that exceeds 20 m, the intermittent duty zone in the torque-motor speed characteristics will become smaller because the voltage drop increases.

3. Refer to the following manual for the following information.

- Cable dimensional drawings and cable connection specifications
- Order numbers and specifications of individual connectors for cables
- Order numbers and specifications for wiring materials

📖 **Σ-7-Series AC Servo Drive Peripheral Device Selection Manual (Manual No.: SIEP S80001 32)**

### ◆ Servomotor Main Circuit Cables

Servomotor Model	Length (L)	Order Number		Appearance
		Standard Cable	Flexible Cable*1	
SGM7F-□□A SGM7F-□□B SGM7F-□□C SGM7F-□□D Flange specification*2: 1 Non-load side installation	3 m	JZSP-CMM60-03-E	JZSP-C7MDN23-03-E	
	5 m	JZSP-CMM60-05-E	JZSP-C7MDN23-05-E	
	10 m	JZSP-CMM60-10-E	JZSP-C7MDN23-10-E	
	15 m	JZSP-CMM60-15-E	JZSP-C7MDN23-15-E	
	20 m	JZSP-CMM60-20-E	JZSP-C7MDN23-20-E	
SGM7F-□□A SGM7F-□□B SGM7F-□□C SGM7F-□□D Flange specification*2: 4 Non-load side installation (with cable on side)	3 m	JZSP-CMM00-03-E	JZSP-C7MDS23-03-E	
	5 m	JZSP-CMM00-05-E	JZSP-C7MDS23-05-E	
	10 m	JZSP-CMM00-10-E	JZSP-C7MDS23-10-E	
	15 m	JZSP-CMM00-15-E	JZSP-C7MDS23-15-E	
	20 m	JZSP-CMM00-20-E	JZSP-C7MDS23-20-E	

\*1. Use Flexible Cables for moving parts of machines, such as robots. Flexible cable recommended bending radius is listed in the following table

\*2. Refer to the following section for the flange specifications.

**Model Designations (page 136)**

Note: Direct Drive Servomotors are not available with holding brakes.

### ◆ Encoder Cables of 20 m or Less

Servomotor Model	Name	Length (L)	Order Number		Appearance
			Standard Cable	Flexible Cable*1	
SGM7F-□□□F Flange specification*2: 1 or 3	For incremental encoder	3 m	JZSP-CMP60-03-E	JZSP-CSP60-03-E	
		5 m	JZSP-CMP60-05-E	JZSP-CSP60-05-E	
		10 m	JZSP-CMP60-10-E	JZSP-CSP60-10-E	
		15 m	JZSP-CMP60-15-E	JZSP-CSP60-15-E	
		20 m	JZSP-CMP60-20-E	JZSP-CSP60-20-E	
SGM7F-□□AF SGM7F-□□BF SGM7F-□□CF SGM7F-□□DF Flange specification*2: 4	For incremental encoder	3 m	JZSP-CMP00-03-E	JZSP-CMP10-03-E	
		5 m	JZSP-CMP00-05-E	JZSP-CMP10-05-E	
		10 m	JZSP-CMP00-10-E	JZSP-CMP10-10-E	
		15 m	JZSP-CMP00-15-E	JZSP-CMP10-15-E	
20 m	JZSP-CMP00-20-E	JZSP-CMP10-20-E			

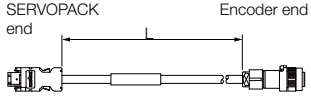
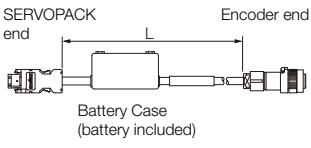
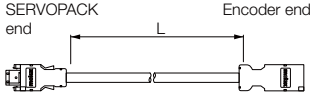
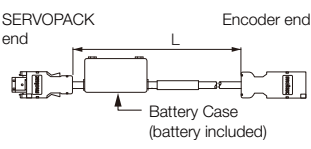

Servomotor Model	Name	Length (L)	Order Number		Appearance
			Standard Cable	Flexible Cable*1	
SGM7F-□□□7  Flange specification*2: 1 or 3	For multi-turn absolute encoder (without Battery Case*3)	3 m	JZSP-C7PI00-03-E	JZSP-C7PI20-03-E	
		5 m	JZSP-C7PI00-05-E	JZSP-C7PI20-05-E	
		10 m	JZSP-C7PI00-10-E	JZSP-C7PI20-10-E	
		15 m	JZSP-C7PI00-15-E	JZSP-C7PI20-15-E	
		20 m	JZSP-C7PI00-20-E	JZSP-C7PI20-20-E	
	For multi-turn absolute encoder (with Battery Case)	3 m	JZSP-C7PA00-03-E	JZSP-C7PA20-03-E	
		5 m	JZSP-C7PA00-05-E	JZSP-C7PA20-05-E	
		10 m	JZSP-C7PA00-10-E	JZSP-C7PA20-10-E	
		15 m	JZSP-C7PA00-15-E	JZSP-C7PA20-15-E	
		20 m	JZSP-C7PA00-20-E	JZSP-C7PA20-20-E	
SGM7F-□□A7 SGM7F-□□B7 SGM7F-□□C7 SGM7F-□□D7  Flange specification*2: 4	For multi-turn absolute encoder (without Battery Case*3)	3 m	JZSP-CMP00-03-E	JZSP-CMP10-03-E	
		5 m	JZSP-CMP00-05-E	JZSP-CMP10-05-E	
		10 m	JZSP-CMP00-10-E	JZSP-CMP10-10-E	
		15 m	JZSP-CMP00-15-E	JZSP-CMP10-15-E	
		20 m	JZSP-CMP00-20-E	JZSP-CMP10-20-E	
	For multi-turn absolute encoder (with Battery Case)	3 m	JZSP-CSP19-03-E	JZSP-CSP29-03-E	
		5 m	JZSP-CSP19-05-E	JZSP-CSP29-05-E	
		10 m	JZSP-CSP19-10-E	JZSP-CSP29-10-E	
		15 m	JZSP-CSP19-15-E	JZSP-CSP29-15-E	
		20 m	JZSP-CSP19-20-E	JZSP-CSP29-20-E	

\*1. Use Flexible Cables for moving parts of machines, such as robots. The recommended bending radius (R) is 68 mm or larger.

\*2. Refer to the following section for the flange specifications.

 **Model Designations (page 136)**

\*3. Use one of these Cables if a battery is connected to the host controller.

## Direct Drive Servo Motors

SGM7F (With Core, Inner Rotor)

### ◆ Relay Encoder Cables of 30 m to 50 m

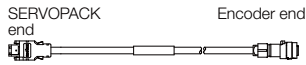
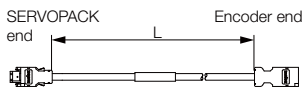
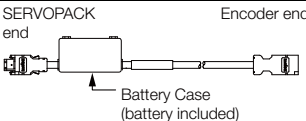
Servomotor Model	Name	Length (L)	Order Number*1	Appearance
SGM7F-□□□F SGM7F-□□□7 Flange specification*2: 1 or 3	Encoder-end Cable (for single-turn/multi-turn absolute encoder)	0.3 m	JZSP-C7PRC0-E	
SGM7F-□□□F SGM7F-□□□7 Flange specification*2: 1, 3 or 4	Cables with Connectors on Both Ends (for single-turn/multi-turn absolute encoder)	30 m	JZSP-UCMP00-30-E	
		40 m	JZSP-UCMP00-40-E	
		50 m	JZSP-UCMP00-50-E	
SGM7F-□□□7 Flange specification*2: 1, 3 or 4	Cable with a Battery Case (for multiturn absolute encoder)*3	0.3 m	JZSP-CSP12-E	

\*1. Flexible Cables are not available.

\*2. Refer to the following section for the flange specifications.

 **Model Designations (page 136)**

\*3. Use one of these Cables if a battery is connected to the host controller.



# SGMCS (Small Capacity, Coreless or Medium Capacity, with Core)

## Model Designations

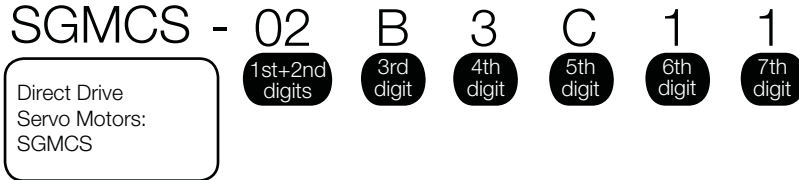

**1st+2nd digits** Rated Output

- Small-Capacity, Coreless

Code	Specification
02	2 N·m
04	4 N·m
05	5 N·m
07	7 N·m
08	8 N·m
10	10 N·m
14	14 N·m
16	16 N·m
17	17 N·m
25	25 N·m
35	35 N·m

- Medium-Capacity, with Core

Code	Specification
45	45 N·m
80	80 N·m
1A	110 N·m
1E	150 N·m
2Z	200 N·m

**3rd digit** Servo Motor Outer Diameter

Code	Specification
B	135-mm dia.
C	175-mm dia.
D	230-mm dia.
E	290-mm dia.
M	280-mm dia.
N	360-mm dia.

**4th digit** Serial Encoder

Code	Specification
3	20-bit single-turn absolute encoder
D	20-bit incremental encoder

**5th digit** Design Revision Order

Code	Specification
A	Model with servo Motor outer diameter code M or N
B	Model with servo Motor outer diameter code E
C	Model with servo Motor outer diameter code B, C, or D

**6th digit** Flange

Code	Mounting	Servo Motor Outer Diameter Code (3rd Digit)					
		B	C	D	E	M	N
1	Non-load side	✓	✓	✓	✓	-	-
	Load side	-	-	-	-	✓	✓
3	Non-load side	-	-	-	-	✓	✓
4	Non-load side (with cable on side)	✓	✓	✓	✓	-	-

✓ : Applicable models.   ■ Non Stock Items

**7th digit** Options

Code	Specification
1	Without options

Note: Direct Drive Servo Motors are not available with holding brakes.

## Specifications and Ratings

### Small-Capacity, Coreless Servo Motors: Specifications

Voltage		200 V											
Model SGMCS-		02B	05B	07B	04C	10C	14C	08D	17D	25D	16E	35E	
Time Rating		Continuous											
Thermal Class		A											
Insulation Resistance		500 VDC, 10 MΩmin.											
Withstand Voltage		1,500 VAC for 1 minute											
Excitation		Permanent magnet											
Mounting		Flange-mounted											
Drive Method		Direct drive											
Rotation Direction		Counterclockwise (CCW) for forward reference when viewed from the load side											
Vibration Class <sup>*1</sup>		V15											
Absolute Accuracy		±15 s											
Repeatability		±1.3 s											
Protective Structure <sup>*2</sup>		Totally enclosed, self-cooled, IP42											
Environmental Conditions	Surrounding Air Temperature	0°C to 40°C (with no freezing)											
	Surrounding Air Humidity	20% to 80% relative humidity (with no condensation)											
	Installation Site	<ul style="list-style-type: none"> <li>• Must be indoors and free of corrosive and explosive gases.</li> <li>• Must be well-ventilated and free of dust and moisture.</li> <li>• Must facilitate inspection and cleaning.</li> <li>• Must have an altitude of 1,000 m or less.</li> <li>• Must be free of strong magnetic fields.</li> </ul>											
	Storage Environment	Store the Servo Motor in the following environment if you store it with the power cable disconnected. Storage Temperature: -20°C to 60°C (with no freezing) Storage Humidity: 20% to 80% relative humidity (with no condensation)											
Mechanical Tolerances <sup>*3</sup>	Runout of Output Shaft Surface	mm	0.02										
	Runout at End of Output Shaft	mm	0.04										
	Parallelism between Mounting Surface and Output Shaft Surface	mm	0.07					0.08					
	Concentricity between Output Shaft and Flange Outer Diameter	mm	0.07					0.08					
Shock Resistance <sup>*4</sup>	Impact Acceleration Rate at Flange	490 m/s <sup>2</sup>											
	Number of Impacts	2 times											
Vibration Resistance <sup>*5</sup>	Vibration Acceleration Rate at Flange	49 m/s <sup>2</sup>											
Applicable SERVOPACKs	SGD7S-	2R8A										5R5A	
	SGD7W-												

\*1. A vibration class of V15 indicates a vibration amplitude of 15 μm maximum on the Servo Motor without a load at the rated motor speed.

\*2. The hollow hole section, motor mounting surface, output shaft surface, and gap around the rotating part of the shaft are excluded. Protective structure specifications apply only when the special cable is used.

## Direct Drive Servo Motors

### SGMCS (Small Capacity, Coreless or Medium Capacity, with Core)

- \*3. Refer to the following figure for the relevant locations on the Servo Motor. Refer to the dimensional drawings of the individual Servo Motors for more information on tolerances.

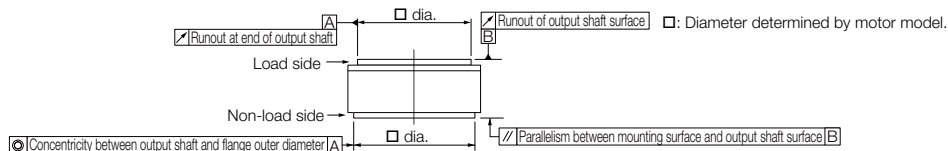

- \*4. The shock resistance for shock in the vertical direction when the Servo Motor is mounted with the shaft in a horizontal position is given in the above table.



Shock Applied to the Servo Motor

- \*5. The vertical, side-to-side, and front-to-back vibration resistance for vibration in three directions when the Servo Motor is mounted with the shaft in a horizontal position is given in the above table. The strength of the vibration that the Servo Motor can withstand depends on the application. Always confirm the vibration acceleration rate.

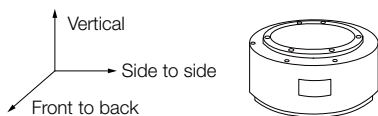

## Small-Capacity, Coreless Servo Motors: Ratings

Voltage		200 V											
Model SGMCS-		02B	05B	07B	04C	10C	14C	08D	17D	25D	16E	35E	
Rated Output <sup>*1</sup>	W	42	105	147	84	209	293	168	356	393	335	550	
Rated Torque <sup>*1, *2</sup>	N•m	2.00	5.00	7.00	4.00	10.0	14.0	8.00	17.0	25.0	16.0	35.0	
Instantaneous Maximum Torque <sup>*1</sup>	N•m	6.00	15.0	21.0	12.0	30.0	42.0	24.0	51.0	75.0	48.0	105	
Stall Torque <sup>*1</sup>	N•m	2.05	5.15	7.32	4.09	10.1	14.2	8.23	17.4	25.4	16.5	35.6	
Rated Current <sup>*1</sup>	Arms	1.8	1.7	1.4	2.2		2.8	1.9	2.5	2.6	3.3	3.5	
Instantaneous Maximum Current <sup>*1</sup>	Arms	5.4	5.1	4.1	7.0		8.3	5.6	7.5	8.0	9.4	10.0	
Rated Motor Speed <sup>*1</sup>	min <sup>-1</sup>	200			200			200		150	200	150	
Maximum Motor Speed <sup>*1</sup>	min <sup>-1</sup>	500			500	400	300	500	350	250	500	250	
Torque Constant	N•m/Arms	1.18	3.17	5.44	2.04	5.05	5.39	5.10	7.79	10.8	5.58	11.1	
Motor Moment of Inertia	×10 <sup>-4</sup> kg•m <sup>2</sup>	28.0	51.0	77.0	77.0	140	220	285	510	750	930	1430	
Rated Power Rate <sup>*1</sup>	kW/s	1.43	4.90	6.36	2.08	7.14	8.91	2.25	5.67	8.33	2.75	8.57	
Rated Angular Acceleration Rate <sup>*1</sup>	rad/s <sup>2</sup>	710	980	910	520	710	640	280	330		170	240	
Heat Sink Size	mm	350 × 350 × 12			450 × 450 × 12			550 × 550 × 12			650 × 650 × 12		
Allowable Load <sup>*3</sup>	Allowable Thrust Load	N	1500			3300			4000			11000	
	Allowable Moment Load	N•m	40	50	64	70	75	90	93	103	135	250	320

\*1. These values are for operation in combination with a SERVOPACK when the temperature of the armature winding is 100°C. The values for other items are at 20°C. These are typical values.

\*2. The rated torques are the continuous allowable torque values at a surrounding air temperature of 40°C with a steel heat sink of the dimensions given in the table.

\*3. The thrust loads and moment loads that are applied while a Servo Motor is operating are roughly classified into the following patterns. Design the machine so that the thrust loads or moment loads will not exceed the values given in the table.

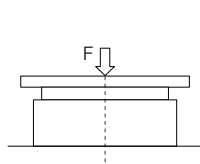

Where F is the external force,  
Thrust load = F + Load mass  
Moment load = 0

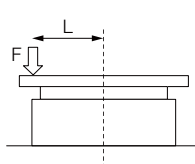

Where F is the external force,  
Thrust load = F + Load mass  
Moment load = F × L

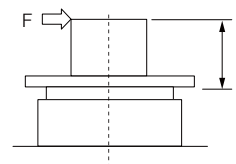

Where F is the external force  
Thrust load = Load mass  
Moment load = F × L

Note: For the bearings used in these Servo Motors, the loss depends on the bearing temperature. The amount of heat loss is higher at low temperatures.

## Small-Capacity, Coreless Servo Motors: Torque-Motor Speed Characteristics

A : Continuous duty zone    ——— (solid lines): With three-phase 200-V input  
B : Intermittent duty zone    - - - - - (dotted lines): With single-phase 100-V input

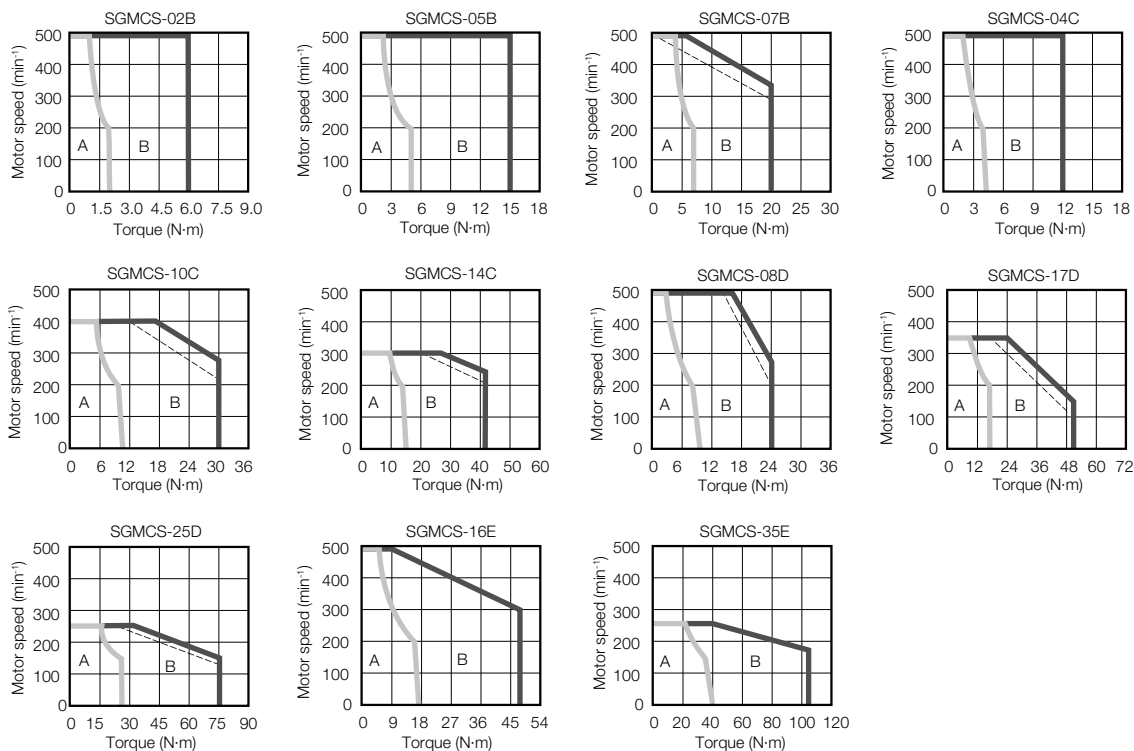

- Note: 1. These values are for operation in combination with a SERVOPACK when the temperature of the armature winding is 100°C. These are typical values.
2. The characteristics in the intermittent duty zone depend on the power supply voltage.
3. If the effective torque is within the allowable range for the rated torque, the Servo Motor can be used within the intermittent duty zone.
4. If you use a Servo Motor Main Circuit Cable that exceeds 20 m, the intermittent duty zone in the torque-motor speed characteristics will become smaller because the voltage drop increases.



## Small-Capacity, Coreless Servo Motors: Servo Motor Overload Protection Characteristics

The overload detection level is set for hot start conditions with a Servo Motor surrounding air temperature of 40°C.

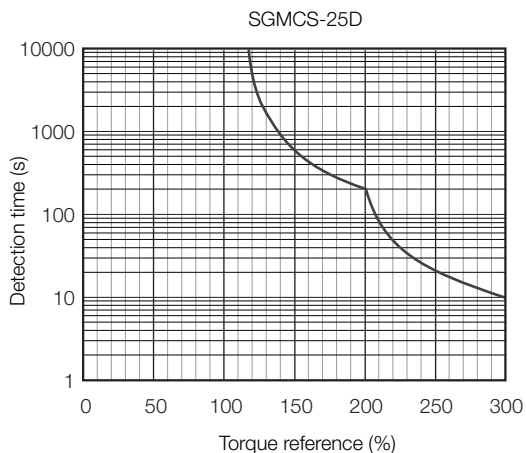
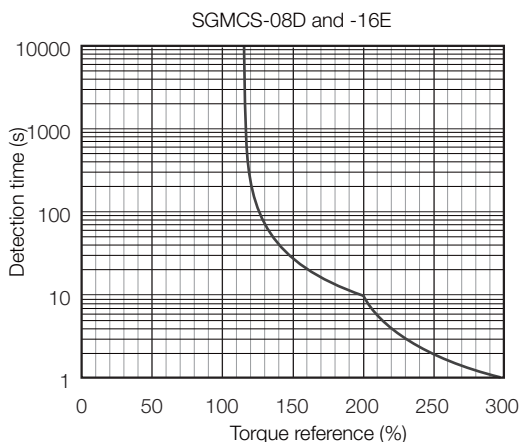
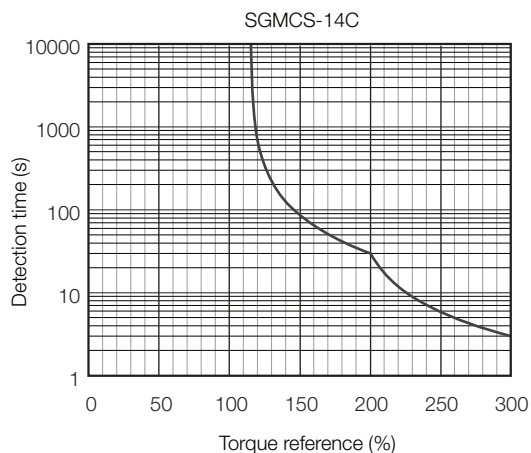
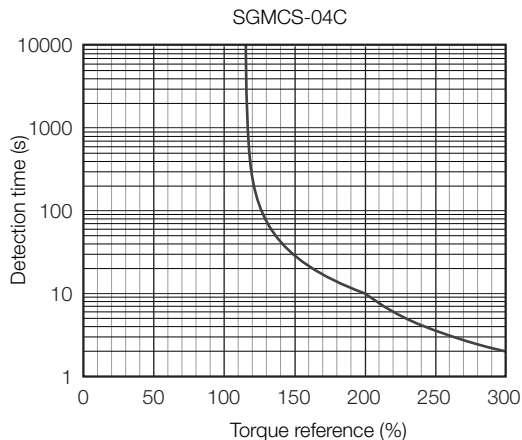
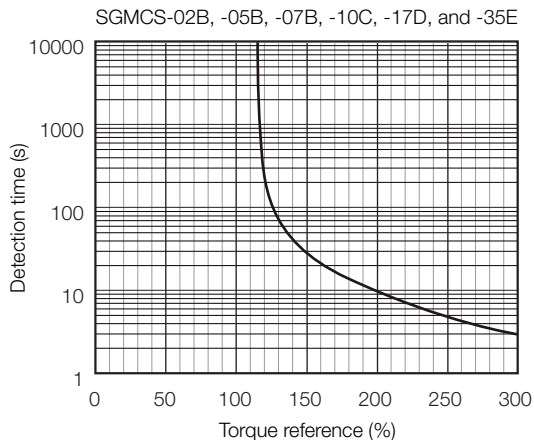

Note: The above overload protection characteristics do not mean that you can perform continuous duty operation with an output of 100% or higher. Use the Servo Motor so that the effective torque remains within the continuous duty zone given in *Small-Capacity, Coreless Servo Motors: Torque-Motor Speed Characteristics* on page 156.

## Direct Drive Servo Motors

SGMCS (Small Capacity, Coreless or Medium Capacity, with Core)

### Medium-Capacity Servo Motors with Cores: Specifications

Voltage		200 V					
Model SGMCS-		45M	80M	1AM	80N	1EN	2ZN
Time Rating		Continuous					
Thermal Class		F					
Insulation Resistance		500 VDC, 10 MΩmin.					
Withstand Voltage		1,500 VAC for 1 minute					
Excitation		Permanent magnet					
Mounting		Flange-mounted					
Drive Method		Direct drive					
Rotation Direction		Counterclockwise (CCW) for forward reference when viewed from the load side					
Vibration Class <sup>*1</sup>		V15					
Absolute Accuracy		±15 s					
Repeatability		±1.3 s					
Protective Structure <sup>*2</sup>		Totally enclosed, self-cooled, IP44					
Environmental Conditions	Surrounding Air Temperature	0°C to 40°C (with no freezing)					
	Surrounding Air Humidity	20% to 80% relative humidity (with no condensation)					
	Installation Site	<ul style="list-style-type: none"> <li>• Must be indoors and free of corrosive and explosive gases.</li> <li>• Must be well-ventilated and free of dust and moisture.</li> <li>• Must facilitate inspection and cleaning.</li> <li>• Must have an altitude of 1,000 m or less.</li> <li>• Must be free of strong magnetic fields.</li> </ul>					
	Storage Environment	Store the Servo Motor in the following environment if you store it with the power cable disconnected. Storage Temperature: -20°C to 60°C (with no freezing) Storage Humidity: 20% to 80% relative humidity (with no condensation)					
Mechanical Tolerances <sup>*3</sup>	Runout of Output Shaft Surface	mm	0.02				
	Runout at End of Output Shaft	mm	0.04				
	Parallelism between Mounting Surface and Output Shaft Surface	mm	-				
	Concentricity between Output Shaft and Flange Outer Diameter	mm	0.08				
	Perpendicularity between Mounting Surface and Output Shaft	mm	0.08				
Shock Resistance <sup>*4</sup>	Impact Acceleration Rate at Flange	490 m/s <sup>2</sup>					
	Number of Impacts	2 times					
Vibration Resistance <sup>*5</sup>	Vibration Acceleration Rate at Flange	24.5 m/s <sup>2</sup>					
Applicable SERVO-PACKS	SGD7S-	7R6A	120A	180A	120A	200 A	
	SGD7W-	7R6A	-				

\*1. A vibration class of V15 indicates a vibration amplitude of 15 μm maximum on the Servo Motor without a load at the rated motor speed.

\*2. This does not apply to the shaft opening. Protective structure specifications apply only when the special cable is used.

\*3. Refer to the following figure for the relevant locations on the Servo Motor. Refer to the dimensional drawings of the individual Servo Motors for more information on tolerances.

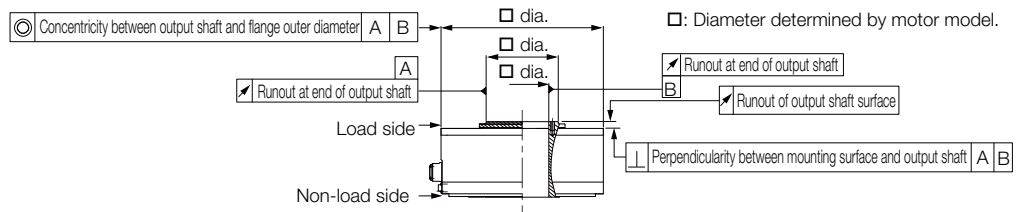

\*4. The shock resistance for shock in the vertical direction when the Servo Motor is mounted with the shaft in a horizontal position is given in the above table.



Shock Applied to the Servo Motor

\*5. The vertical, side-to-side, and front-to-back vibration resistance for vibration in three directions when the Servo Motor is mounted with the shaft in a horizontal position is given in the above table. The strength of the vibration that the Servo Motor can withstand depends on the application. Always confirm the vibration acceleration rate.

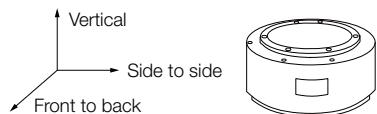

## Medium-Capacity Servo Motors with Cores: Ratings

Voltage		200 V					
Model SGMCS-		45M	80M	1AM	80N	1EN	2ZN
Rated Output <sup>*1</sup>	W	707	1260	1730	1260	2360	3140
Rated Torque <sup>*1, *2</sup>	N•m	45.0	80.0	110	80.0	150	200
Instantaneous Maximum Torque <sup>*1</sup>	N•m	135	240	330	240	450	600
Stall Torque <sup>*1</sup>	N•m	45.0	80.0	110	80.0	150	200
Rated Current <sup>*1</sup>	Arms	5.8	9.7	13.4	9.4	17.4	18.9
Instantaneous Maximum Current <sup>*1</sup>	Arms	17.0	28.0	42.0	28.0	56.0	56.0
Rated Motor Speed <sup>*1</sup>	min <sup>-1</sup>	150			150		
Maximum Motor Speed <sup>*1</sup>	min <sup>-1</sup>	300			300	250	
Torque Constant	N•m/Arms	8.39	8.91	8.45	9.08	9.05	11.5
Motor Moment of Inertia	$\times 10^{-4}$ kg•m <sup>2</sup>	388	627	865	1360	2470	3060
Rated Power Rate <sup>*1</sup>	kW/s	52.2	102	140	47.1	91.1	131
Rated Angular Acceleration Rate <sup>*1</sup>	rad/s <sup>2</sup>	1160	1280	1270	588	607	654
Heat Sink Size	mm	750 × 750 × 45					
Allowable Load <sup>*3</sup>	A	mm	33			37.5	
	Allowable Thrust Load	N	9000			16000	
	Allowable Moment Load	N•m	180			350	

\*1. These values are for operation in combination with a SERVOPACK when the temperature of the armature winding is 20°C. These are typical values.

\*2. The rated torques are the continuous allowable torque values at a surrounding air temperature of 40°C with a steel heat sink of the dimensions given in the table.

\*3. The thrust loads and moment loads that are applied while a Servo Motor is operating are roughly classified into the following patterns. Design the machine so that the thrust loads or moment loads will not exceed the values given in the table.

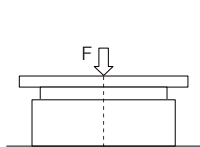

Where F is the external force,  
 Thrust load = F + Load mass  
 Moment load = 0

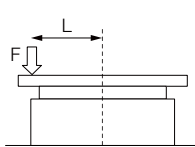

Where F is the external force,  
 Thrust load = F + Load mass  
 Moment load = F × L

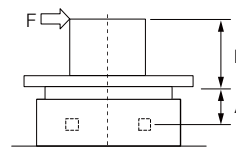

Where F is the external force,  
 Thrust load = Load mass  
 Moment load = F × (L + A)

A (Refer to the values in the table.)

Note: For the bearings used in these Servo Motors, the loss depends on the bearing temperature. The amount of heat loss is higher at low temperatures.

## Medium-Capacity Servo Motors with Cores: Torque-Motor Speed Characteristics

A : Continuous duty zone

B : Intermittent duty zone

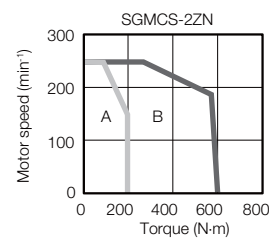
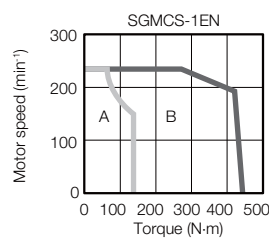
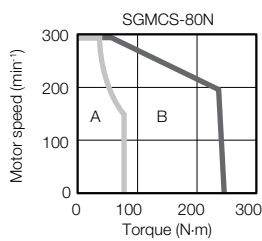
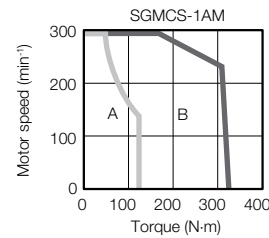
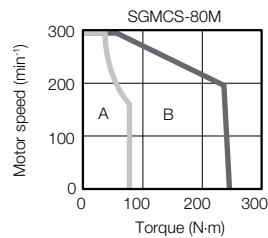
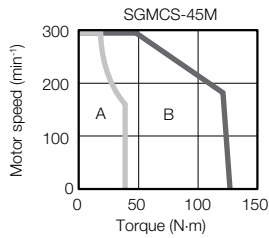

Note: 1. These values are for operation in combination with a SERVOPACK when the temperature of the armature winding is 20°C. These are typical values.

2. If the effective torque is within the allowable range for the rated torque, the Servo Motor can be used within the intermittent duty zone.
3. If you use a Servo Motor Main Circuit Cable that exceeds 20 m, the intermittent duty zone in the torque-motor speed characteristics will become smaller because the voltage drop increases.

## Medium-Capacity Servo Motors with Cores: Servo Motor Overload Protection Characteristics

The overload detection level is set for hot start conditions with a Servo Motor surrounding air temperature of 40°C.

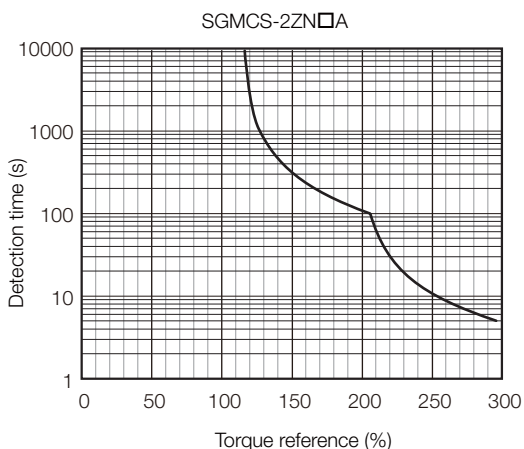
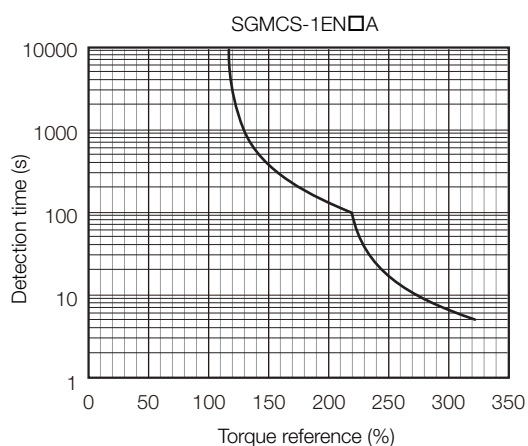
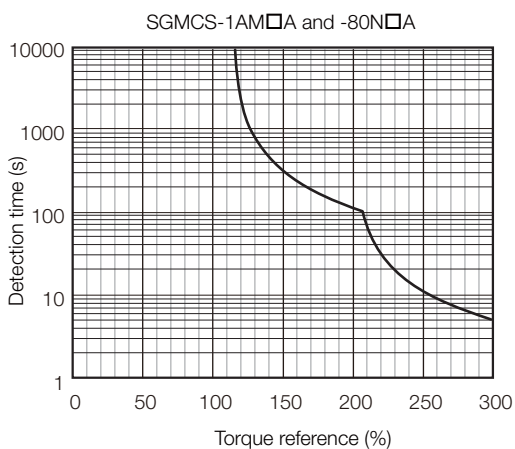
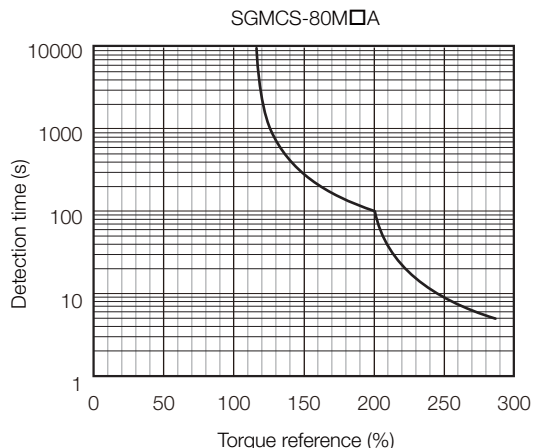
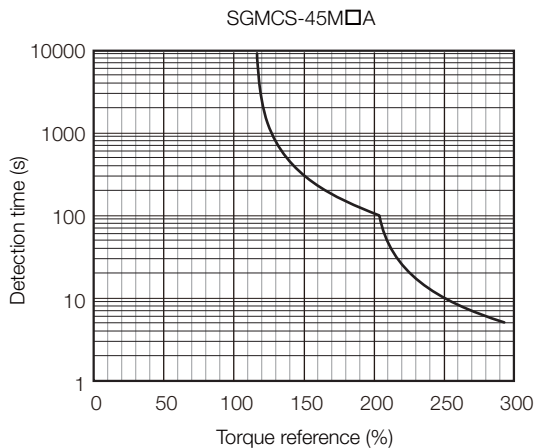

Note: The above overload protection characteristics do not mean that you can perform continuous duty operation with an output of 100% or higher. Use the Servo Motor so that the effective torque remains within the continuous duty zone given in *Medium-Capacity Servo Motors with Cores: Torque-Motor Speed Characteristics* on page 161.

## Allowable Load Moment of Inertia Scaling Factor for SERVOPACKS without Built-in Regenerative Resistors

The following graphs show the allowable load moment of inertia scaling factor of the motor speed for SERVOPACKS without built-in regenerative resistors when an External Regenerative Resistor is not connected (applicable SERVOPACK: SGD7S-2R8A).

If the Servo Motor exceeds the allowable load moment of inertia, an overvoltage alarm may occur in the SERVOPACK.

These graphs provide reference data for deceleration at the rated torque or higher with a 200-VAC power supply input.

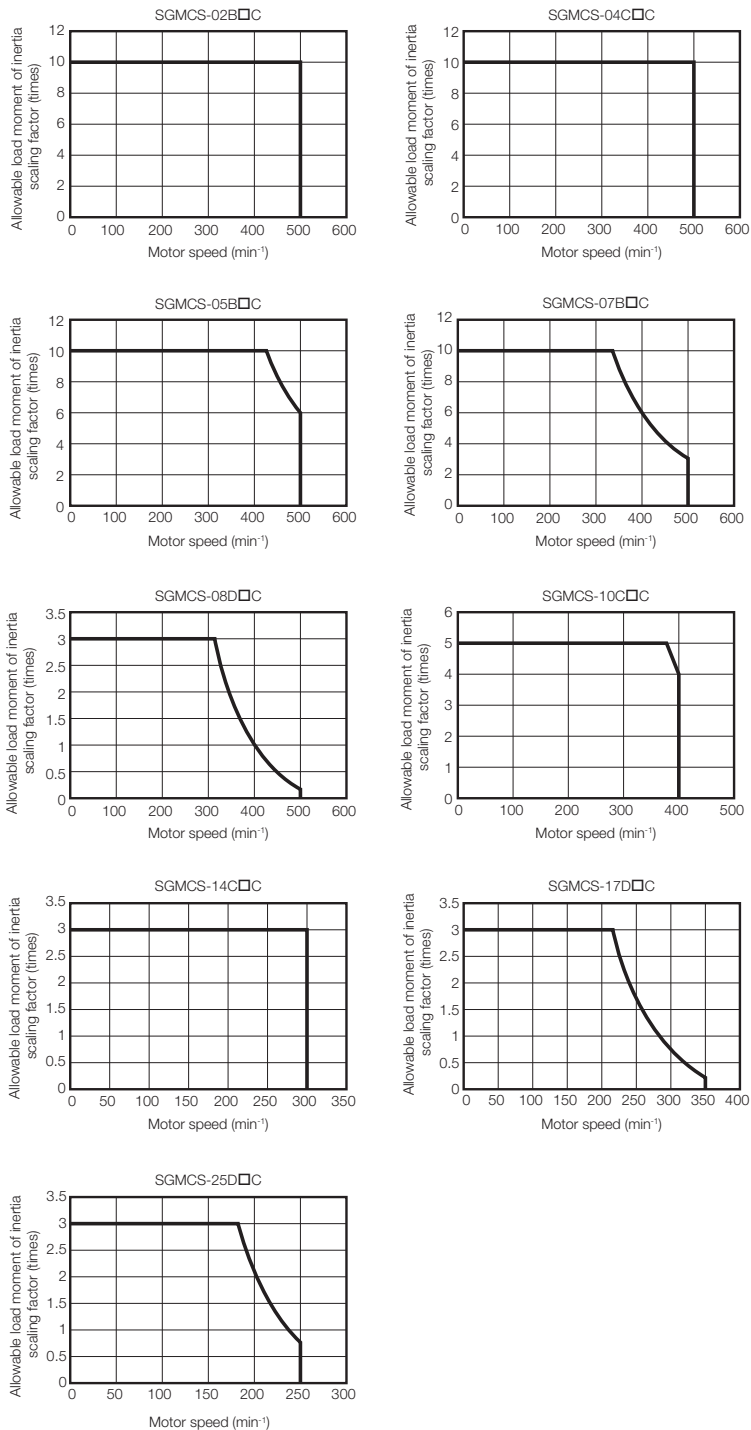

## External Dimensions

### Small-Capacity, Coreless Servo Motors

#### ◆ SGMCS-□ □ B

##### • Flange Specification 1

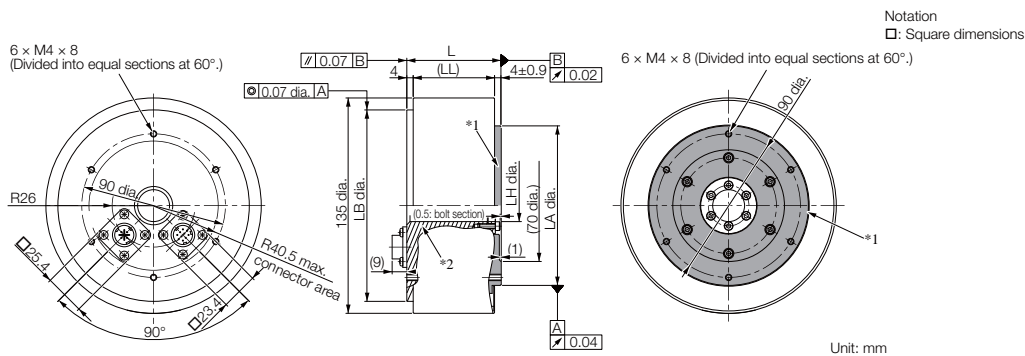

\*1. The shaded section indicates the rotating parts.

\*2. The hatched section indicates the non-rotating parts.

Note: Values in parentheses are reference dimensions.

Model SGMCS-	L	(LL)	LB	LH	LA	Approx. Mass [kg]
02B□C11	59	51	120 <sup>0</sup> <sub>-0.035</sub>	20 <sup>+0.4</sup> <sub>0</sub>	100 <sup>0</sup> <sub>-0.035</sub>	4.8
05B□C11	88	80	120 <sup>0</sup> <sub>-0.035</sub>	20 <sup>+0.4</sup> <sub>0</sub>	100 <sup>0</sup> <sub>-0.035</sub>	5.8
07B□C11	128	120	120 <sup>0</sup> <sub>-0.035</sub>	20 <sup>+0.4</sup> <sub>0</sub>	100 <sup>0</sup> <sub>-0.035</sub>	8.2

##### • Flange Specification 4

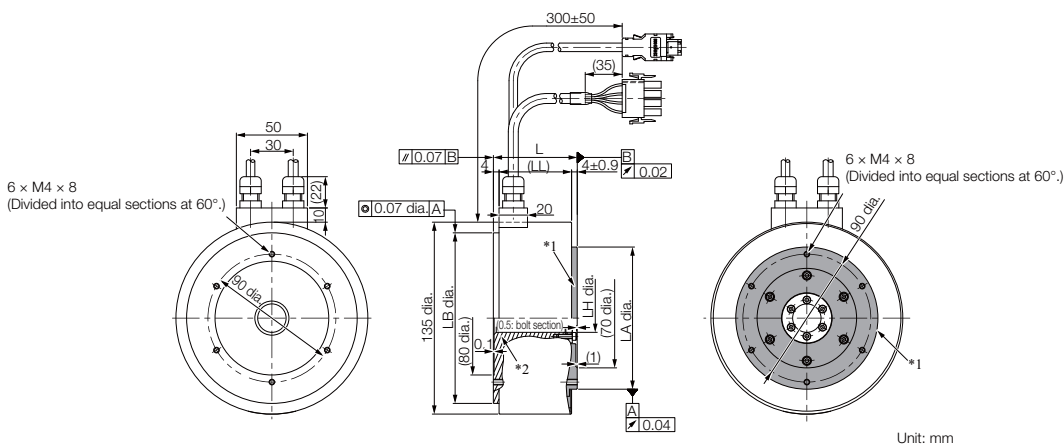

\*1. The shaded section indicates the rotating parts.

\*2. The hatched section indicates the non-rotating parts.

Note: Values in parentheses are reference dimensions.

Model SGMCS-	L	(LL)	LB	LH	LA	Approx. Mass [kg]
02B□C41	59	51	120 <sup>0</sup> <sub>-0.035</sub>	20 <sup>+0.4</sup> <sub>0</sub>	100 <sup>0</sup> <sub>-0.035</sub>	4.8
05B□C41	88	80	120 <sup>0</sup> <sub>-0.035</sub>	20 <sup>+0.4</sup> <sub>0</sub>	100 <sup>0</sup> <sub>-0.035</sub>	5.8
07B□C41	128	120	120 <sup>0</sup> <sub>-0.035</sub>	20 <sup>+0.4</sup> <sub>0</sub>	100 <sup>0</sup> <sub>-0.035</sub>	8.2

Refer to the following section for information on connectors.

See Connector Specifications Page 170



◆ SGMCS-□ □ C

• Flange Specification 1

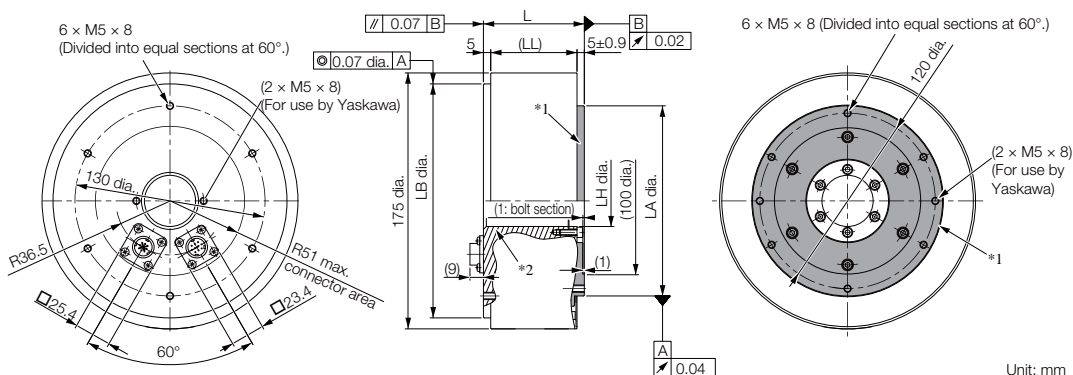

\*1. The shaded section indicates the rotating parts.  
 \*2. The hatched section indicates the non-rotating parts.  
 Note: Values in parentheses are reference dimensions.

Model SGMCS-	L	(LL)	LB	LH	LA	Approx. Mass [kg]
04C□□11	69	59	160 <sup>0</sup> <sub>-0.040</sub>	35 <sup>+0.4</sup> <sub>0</sub>	130 <sup>0</sup> <sub>-0.040</sub>	7.2
10C□□11	90	80	160 <sup>0</sup> <sub>-0.040</sub>	35 <sup>+0.4</sup> <sub>0</sub>	130 <sup>0</sup> <sub>-0.040</sub>	10.2
14C□□11	130	120	160 <sup>0</sup> <sub>-0.040</sub>	35 <sup>+0.4</sup> <sub>0</sub>	130 <sup>0</sup> <sub>-0.040</sub>	14.2

• Flange Specification 4

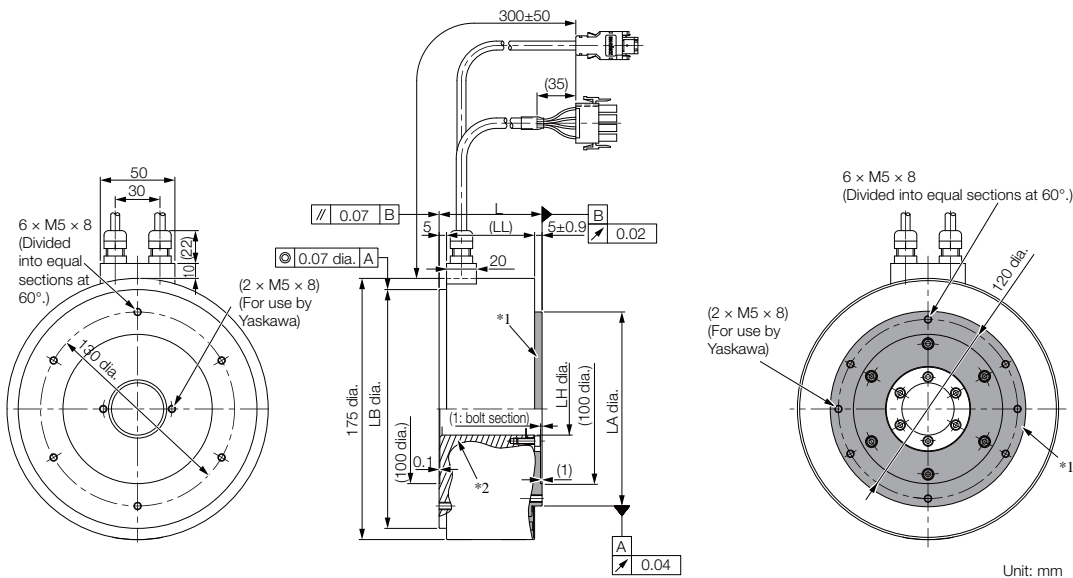

\*1. The shaded section indicates the rotating parts.  
 \*2. The hatched section indicates the non-rotating parts.  
 Note: Values in parentheses are reference dimensions.

Model SGMCS-	L	(LL)	LB	LH	LA	Approx. Mass [kg]
04C□□41	69	59	160 <sup>0</sup> <sub>-0.040</sub>	35 <sup>+0.4</sup> <sub>0</sub>	130 <sup>0</sup> <sub>-0.040</sub>	7.2
10C□□41	90	80	160 <sup>0</sup> <sub>-0.040</sub>	35 <sup>+0.4</sup> <sub>0</sub>	130 <sup>0</sup> <sub>-0.040</sub>	10.2
14C□□41	130	120	160 <sup>0</sup> <sub>-0.040</sub>	35 <sup>+0.4</sup> <sub>0</sub>	130 <sup>0</sup> <sub>-0.040</sub>	14.2

Refer to the following section for information on connectors.

See Connector Specifications Page 170

## Direct Drive Servo Motors

SGMCS (Small Capacity, Coreless or Medium Capacity, with Core)

### ◆ SGMCS-□ □ D

#### • Flange Specification 1

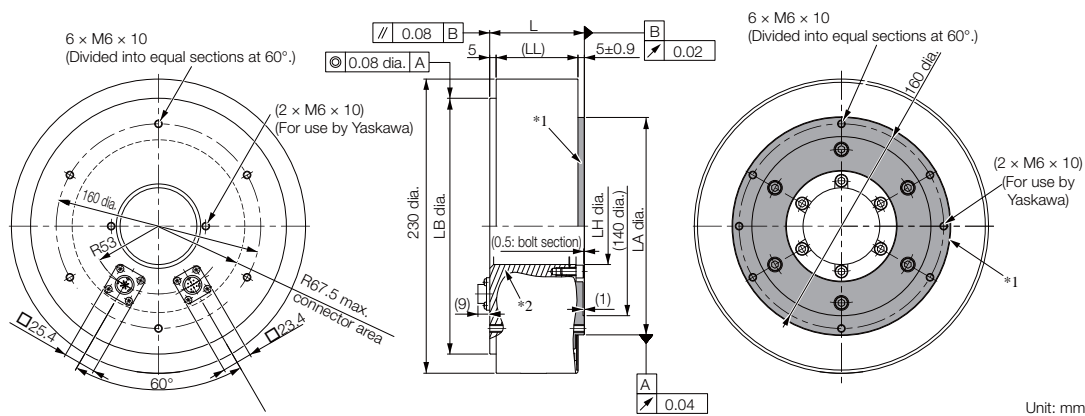

\*1. The shaded section indicates the rotating parts.

\*2. The hatched section indicates the non-rotating parts.

Note: Values in parentheses are reference dimensions.

Model SGMCS-	L	(LL)	LB	LH	LA	Approx. Mass [kg]
08D□□11	74	64	200 <sup>0</sup> <sub>-0.046</sub>	60 <sup>+0.4</sup> <sub>0</sub>	170 <sup>0</sup> <sub>-0.040</sub>	14.0
17D□□11	110	100	200 <sup>0</sup> <sub>-0.046</sub>	60 <sup>+0.4</sup> <sub>0</sub>	170 <sup>0</sup> <sub>-0.040</sub>	22.0
25D□□11	160	150	200 <sup>0</sup> <sub>-0.046</sub>	60 <sup>+0.4</sup> <sub>0</sub>	170 <sup>0</sup> <sub>-0.040</sub>	29.7

#### • Flange Specification 4

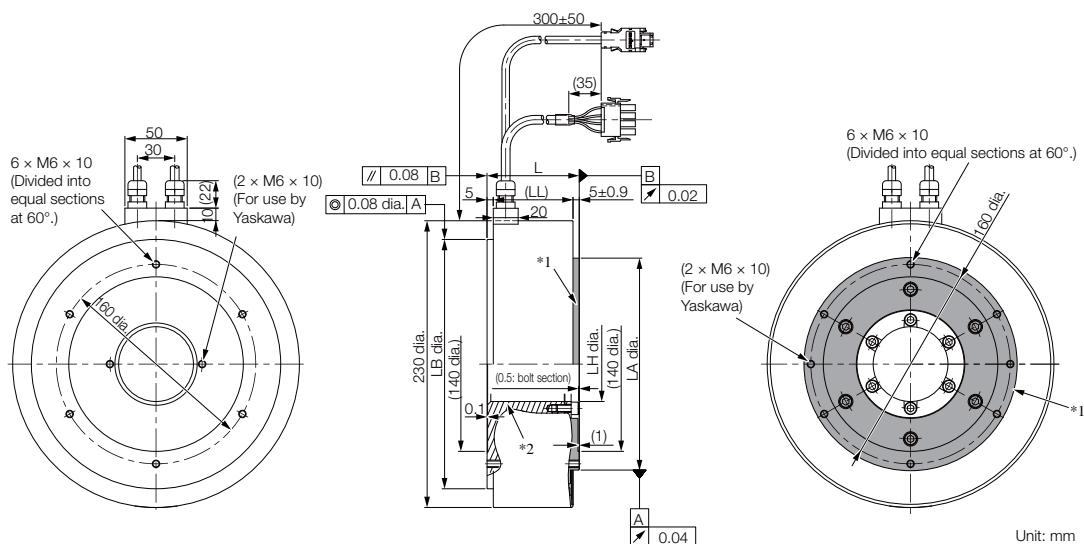

\*1. The shaded section indicates the rotating parts.

\*2. The hatched section indicates the non-rotating parts.

Note: Values in parentheses are reference dimensions.

Model SGMCS-	L	(LL)	LB	LH	LA	Approx. Mass [kg]
08D□□41	74	64	200 <sup>0</sup> <sub>-0.046</sub>	60 <sup>+0.4</sup> <sub>0</sub>	170 <sup>0</sup> <sub>-0.040</sub>	14.0
17D□□41	110	100	200 <sup>0</sup> <sub>-0.046</sub>	60 <sup>+0.4</sup> <sub>0</sub>	170 <sup>0</sup> <sub>-0.040</sub>	22.0
25D□□41	160	150	200 <sup>0</sup> <sub>-0.046</sub>	60 <sup>+0.4</sup> <sub>0</sub>	170 <sup>0</sup> <sub>-0.040</sub>	29.7

Refer to the following section for information on connectors.

☞ See Connector Specifications Page 170

◆ SGMCS-□□E

• Flange Specification 1

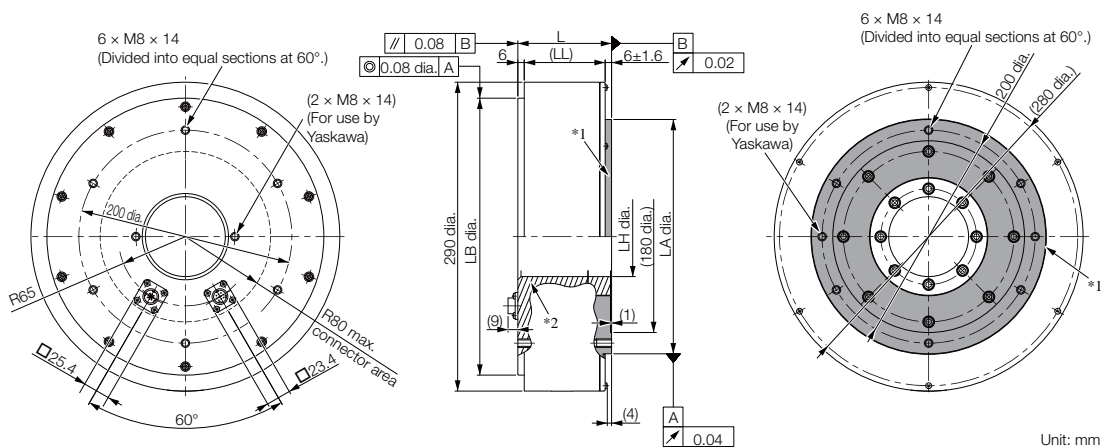

\*1. The shaded section indicates the rotating parts.  
 \*2. The hatched section indicates the non-rotating parts.  
 Note: Values in parentheses are reference dimensions.

Model SGMCS-	L	(LL)	LB	LH	LA	Approx. Mass [kg]
16E□B11	88	76	260 <sup>0</sup> <sub>-0.052</sub>	75 <sup>+0.4</sup> <sub>0</sub>	220 <sup>0</sup> <sub>-0.046</sub>	26.0
35E□B11	112	100	260 <sup>0</sup> <sub>-0.052</sub>	75 <sup>+0.4</sup> <sub>0</sub>	220 <sup>0</sup> <sub>-0.046</sub>	34.0

• Flange Specification 4

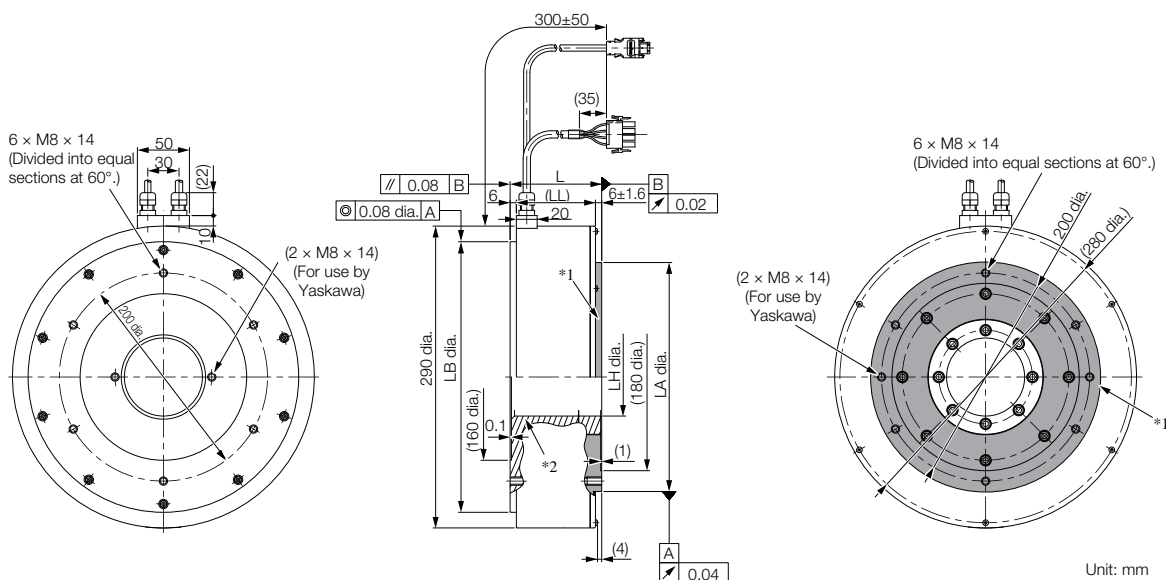

\*1. The shaded section indicates the rotating parts.  
 \*2. The hatched section indicates the non-rotating parts.  
 Note: Values in parentheses are reference dimensions.

Model SGMCS-	L	(LL)	LB	LH	LA	Approx. Mass [kg]
16E□B41	88	76	260 <sup>0</sup> <sub>-0.052</sub>	75 <sup>+0.4</sup> <sub>0</sub>	220 <sup>0</sup> <sub>-0.046</sub>	26.0
35E□B41	112	100	260 <sup>0</sup> <sub>-0.052</sub>	75 <sup>+0.4</sup> <sub>0</sub>	220 <sup>0</sup> <sub>-0.046</sub>	34.0

Refer to the following section for information on connectors.

See Connector Specifications Page 170

## Medium-Capacity Servo Motors with Cores

### ◆ SGMCS-□ □ M

#### • Flange Specification 1

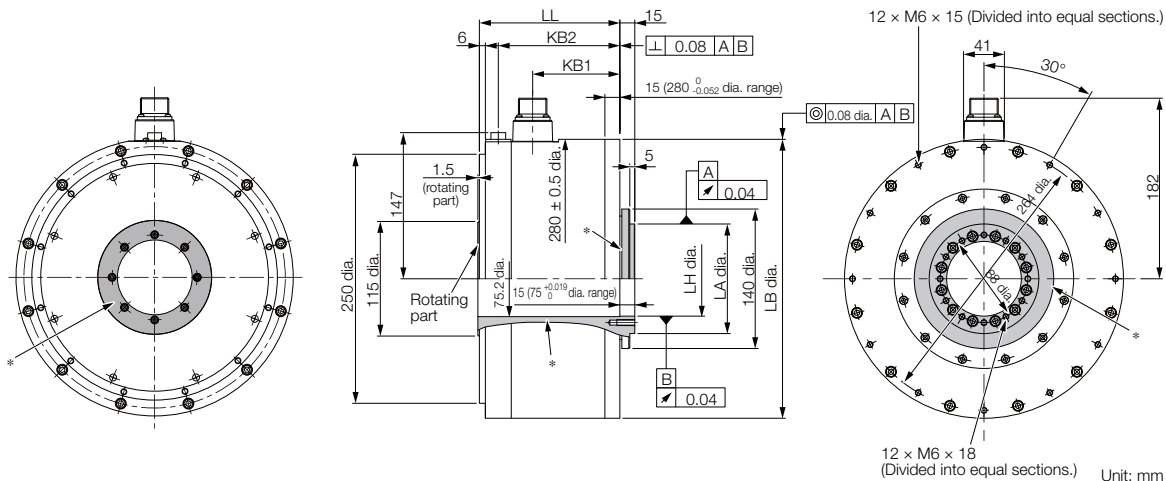

\* The shaded section indicates the rotating parts.

Model SGMCS-	LL	KB1	KB2	LB	LH	LA	Approx. Mass [kg]
45M□A11	141	87.5	122	280 <sup>0</sup> <sub>-0.052</sub>	75 <sup>+0.019</sup> <sub>0</sub>	110 <sup>0</sup> <sub>-0.035</sub>	38
80M□A11	191	137.5	172	280 <sup>0</sup> <sub>-0.052</sub>	75 <sup>+0.019</sup> <sub>0</sub>	110 <sup>0</sup> <sub>-0.035</sub>	45
1AM□A11	241	187.5	222	280 <sup>0</sup> <sub>-0.052</sub>	75 <sup>+0.019</sup> <sub>0</sub>	110 <sup>0</sup> <sub>-0.035</sub>	51

#### • Flange Specification 3

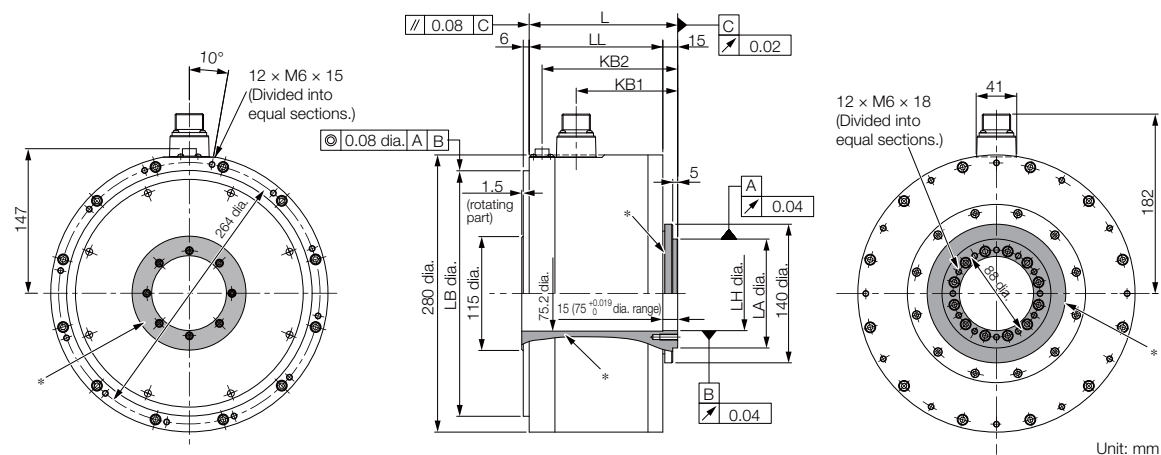

\* The shaded section indicates the rotating parts.

Model SGMCS-	L	LL	KB1	KB2	LB	LH	LA	Approx. Mass [kg]
45M□A31	150	135	102.5	137	248 <sup>0</sup> <sub>-0.046</sub>	75 <sup>+0.019</sup> <sub>0</sub>	110 <sup>0</sup> <sub>-0.035</sub>	38
80M□A31	200	185	152.5	187	248 <sup>0</sup> <sub>-0.046</sub>	75 <sup>+0.019</sup> <sub>0</sub>	110 <sup>0</sup> <sub>-0.035</sub>	45
1AM□A31	250	235	202.5	237	248 <sup>0</sup> <sub>-0.046</sub>	75 <sup>+0.019</sup> <sub>0</sub>	110 <sup>0</sup> <sub>-0.035</sub>	51

Refer to the following section for information on connectors.

See Connector Specifications Page 170

◆ SGMCS-□ □ N

• Flange Specification 1

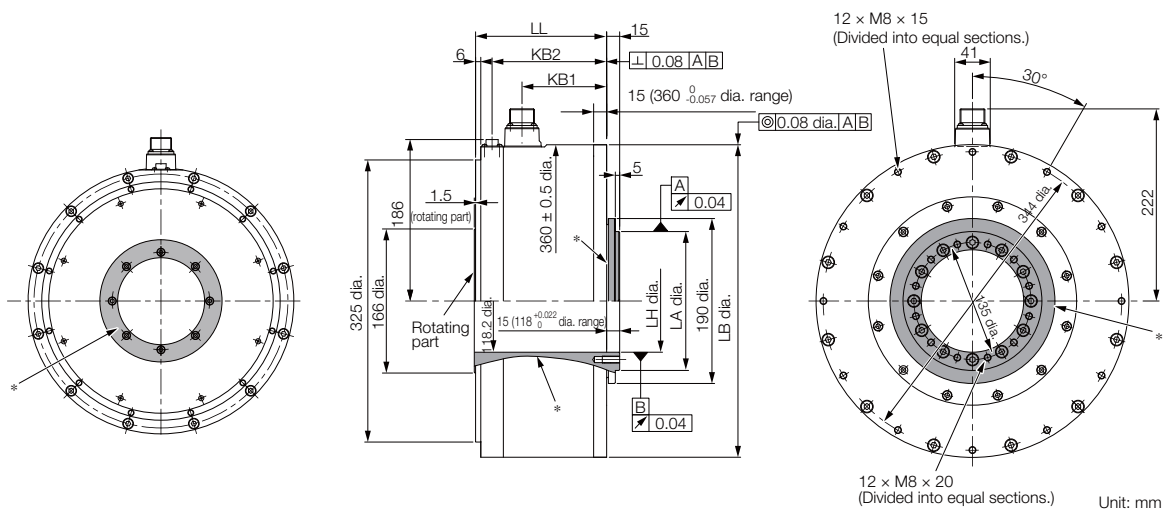

\* The shaded section indicates the rotating parts.

Model SGMCS-	LL	KB1	KB2	LB	LH	LA	Approx. Mass [kg]
80N□A11	151	98	132	360 <sup>0</sup> <sub>-0.057</sub>	118 <sup>+0.022</sup> <sub>0</sub>	160 <sup>0</sup> <sub>-0.040</sub>	50
1EN□A11	201	148	182	360 <sup>0</sup> <sub>-0.057</sub>	118 <sup>+0.022</sup> <sub>0</sub>	160 <sup>0</sup> <sub>-0.040</sub>	68
2ZN□A11	251	198	232	360 <sup>0</sup> <sub>-0.057</sub>	118 <sup>+0.022</sup> <sub>0</sub>	160 <sup>0</sup> <sub>-0.040</sub>	86

• Flange Specification 3

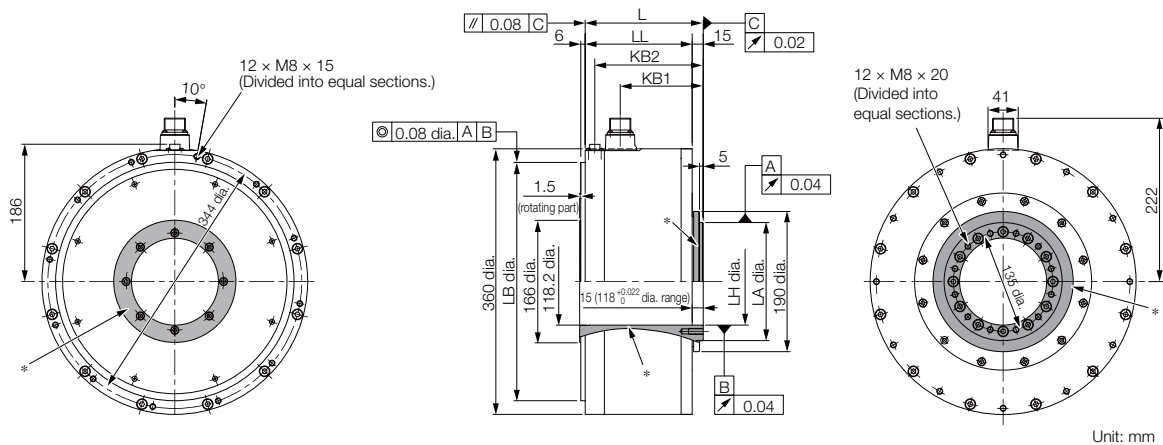

\* The shaded section indicates the rotating parts.

Model SGMCS-	L	LL	KB1	KB2	LB	LH	LA	Approx. Mass [kg]
80N□A31	160	145	113	147	323 <sup>0</sup> <sub>-0.057</sub>	118 <sup>+0.022</sup> <sub>0</sub>	160 <sup>0</sup> <sub>-0.040</sub>	50
1EN□A31	210	195	163	197	323 <sup>0</sup> <sub>-0.057</sub>	118 <sup>+0.022</sup> <sub>0</sub>	160 <sup>0</sup> <sub>-0.040</sub>	68
2ZN□A31	260	245	213	247	323 <sup>0</sup> <sub>-0.057</sub>	118 <sup>+0.022</sup> <sub>0</sub>	160 <sup>0</sup> <sub>-0.040</sub>	86

Refer to the following section for information on connectors.

☞ See Connector Specifications Page 170

## Connector Specifications

### ◆ SGMCS-□ □ B, -□ □ C, -□ □ D, or -□ □ E with Flange Specification 1

#### • Servo Motor Connector Specifications

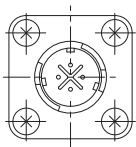

Model: JN1AS04MK2R

Manufacturer: Japan Aviation Electronics Industry, Ltd.

Mating connector: JN1DS04FK1  
(Not provided by Yaskawa.)

#### • Encoder Connector Specifications

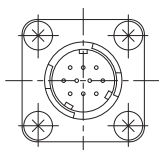

Model: JN1AS10ML1-R

Manufacturer: Japan Aviation Electronics Industry, Ltd.

Mating connector: JN1DS10SL1  
(Not provided by Yaskawa.)

### ◆ SGMCS-□ □ B, -□ □ C, -□ □ D, or -□ □ E with Flange Specification 4

#### • Servo Motor Connector Specifications

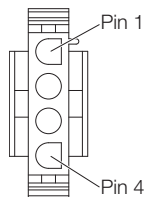

Model

- Plug: 350779-1
  - Pins: 350561-3 or 350690-3 (No.1 to 3)
  - Ground pin: 350654-1 or 350669-1 (No. 4)
- Manufacturer: Tyco Electronics Japan G.K.

Mating Connector

- Cap: 350780-1
- Socket: 350570-3 or 350689-3

#### • Encoder Connector Specifications

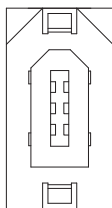

Model: 55102-0600

Manufacturer: Molex Japan Co., Ltd.

Mating connector: 54280-0609

◆ SGMCS-□ □ M or -□ □ N with Flange Specification 1 or 3

• Servo Motor Connector Specifications

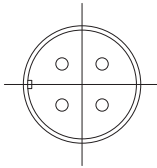

Model: CE05-2A18-10PD  
 Manufacturer: DDK Ltd.

Mating Connector  
 Plug: CE05-6A18-10SD-B-BSS  
 Cable clamp: CE3057-10A-□(D265)

• Encoder Connector Specifications

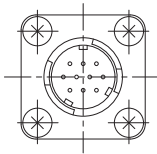

Model: JN1AS10ML1  
 Manufacturer: Japan Aviation Electronics Industry, Ltd.

Mating connector: JN1DS10SL1

## Selecting Cables

### ◆ Cable Configurations

The cables shown below are required to connect a Servo Motor to a SERVOPACK.

Encoder Cable of 20 m or Less

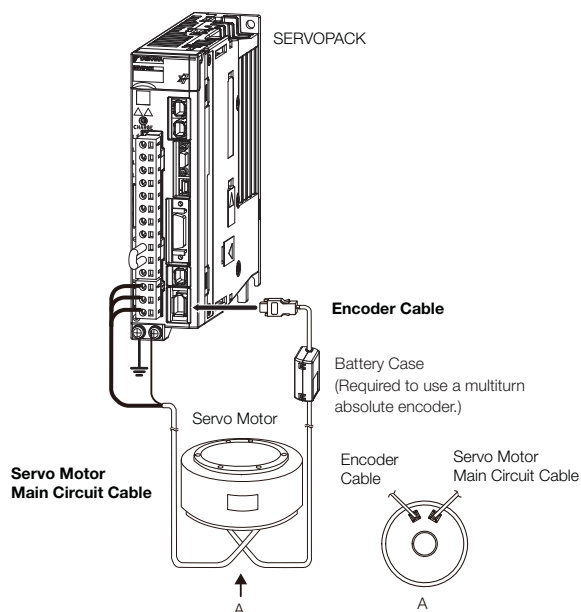

Encoder Cable of 30 m to 50 m (Relay Cable)

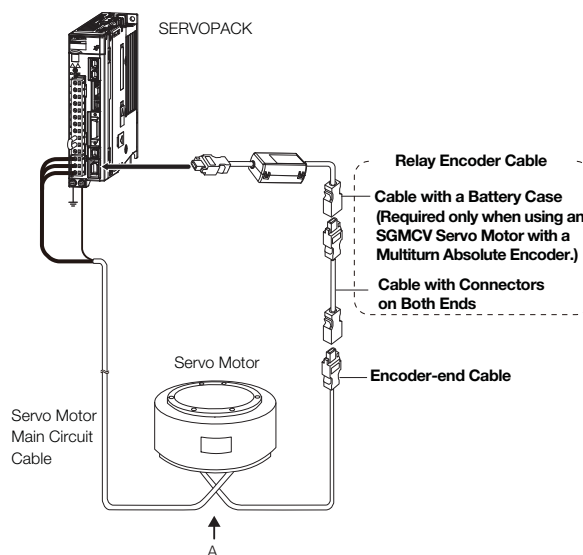

Note: 1. If the cable length exceeds 20 m, be sure to use a Relay Encoder Cable.

2. If you use a Servo Motor Main Circuit Cable that exceeds 20 m, the intermittent duty zone in the torque-motor speed characteristics will become smaller because the voltage drop increases.

3. Refer to the following manual for the following information.

- Cable dimensional drawings and cable connection specifications
- Order numbers and specifications of individual connectors for cables
- Order numbers and specifications for wiring materials

📖 *Σ-7-Series AC Servo Drive Peripheral Device Selection Manual* (Manual No.: SIEP S800001 32)



## Servo Motor Main Circuit Cables

### ◆ SGMCS-□ □

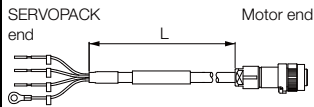
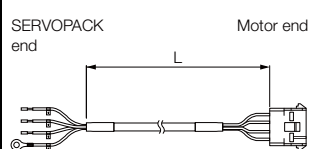
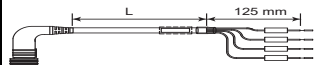
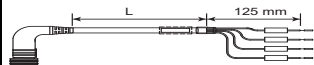
Servo Motor Model	Length (L)	Order Number		Appearance
		Standard Cable	Flexible Cable*1	
SGMCS-□ □ B SGMCS-□ □ C SGMCS-□ □ D SGMCS-□ □ E  Flange specification*2: 1 Non-load side installation	3 m	JZSP-CMM60-03-E	JZSP-CSM60-03-E	
	5 m	JZSP-CMM60-05-E	JZSP-CSM60-05-E	
	10 m	JZSP-CMM60-10-E	JZSP-CSM60-10-E	
	15 m	JZSP-CMM60-15-E	JZSP-CSM60-15-E	
	20 m	JZSP-CMM60-20-E	JZSP-CSM60-20-E	
SGMCS-□ □ B SGMCS-□ □ C SGMCS-□ □ D SGMCS-□ □ E  Flange specification*2: 4 Non-load side installation (with cable on side)	3 m	JZSP-CMM00-03-E	JZSP-CMM01-03-E	
	5 m	JZSP-CMM00-05-E	JZSP-CMM01-05-E	
	10 m	JZSP-CMM00-10-E	JZSP-CMM01-10-E	
	15 m	JZSP-CMM00-15-E	JZSP-CMM01-15-E	
	20 m	JZSP-CMM00-20-E	JZSP-CMM01-20-E	
SGMCS-□ □ M SGMCS-□ □ N □ □ : 45, 80, 1A	3 m	B1EV-03(A)-E	B1EP-03(A)-E	
	5 m	B1EV-05(A)-E	B1EP-05(A)-E	
	10 m	B1EV-10(A)-E	B1EP-10(A)-E	
	15 m	B1EV-15(A)-E	B1EP-15(A)-E	
	20 m	B1EV-20(A)-E	B1EP-20(A)-E	
SGMCS-□ □ N □ □ : 1E, 2Z	3 m	B2EV-03(A)-E	B2EP-03(A)-E	
	5 m	B2EV-05(A)-E	B2EP-05(A)-E	
	10 m	B2EV-10(A)-E	B2EP-10(A)-E	
	15 m	B2EV-15(A)-E	B2EP-15(A)-E	
	20 m	B2EV-20(A)-E	B2EP-20(A)-E	

\*1. Use Flexible Cables for moving parts of machines, such as robots.

\*2. Refer to the following section for the flange specifications.

🔗 See Flange Specifications Page 175

Note: Direct Drive Servo Motors are not available with holding brakes.

## Encoder Cables of 20 m or Less

### ◆ SGMCS-□□

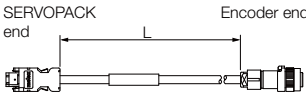
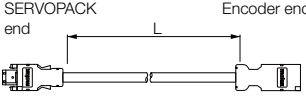
Servo Motor Model	Name	Length (L)	Order Number		Appearance
			Standard Cable	Flexible Cable*1	
SGMCS-□□ Flange specification*2: 1 or 3	For incremental/ absolute encoder	3 m	JZSP-CMP60-03-E	JZSP-CSP60-03-E	
		5 m	JZSP-CMP60-05-E	JZSP-CSP60-05-E	
		10 m	JZSP-CMP60-10-E	JZSP-CSP60-10-E	
		15 m	JZSP-CMP60-15-E	JZSP-CSP60-15-E	
		20 m	JZSP-CMP60-20-E	JZSP-CSP60-20-E	
SGMCS-□□ Flange Specification*2: 4		3 m	JZSP-CMP00-03-E	JZSP-CMP10-03-E	
		5 m	JZSP-CMP00-05-E	JZSP-CMP10-05-E	
		10 m	JZSP-CMP00-10-E	JZSP-CMP10-10-E	
		15 m	JZSP-CMP00-15-E	JZSP-CMP10-15-E	
		20 m	JZSP-CMP00-20-E	JZSP-CMP10-20-E	

\*1. Use Flexible Cables for moving parts of machines, such as robots.

\*2. Refer to the following section for the flange specifications.

■ See Flange Specifications Page 175

## Relay Encoder Cables of 30 m to 50 m

### ◆ SGMCS-□ □

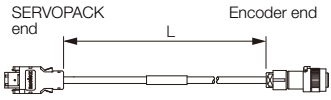
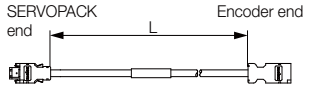
Servo Motor Model	Name	Length (L)	Order Number*1	Appearance
SGMCS-□□ Flange specification*2: 1 or 3	Encoder-end Cable (for incremental or absolute encoder)	0.3 m	JZSP-CSP15-E	
SGMCS-□□ Flange specification*2: 1, 3, or 4	Cables with Connectors on Both Ends (for incremental or absolute encoder)	30 m	JZSP-UCMP00-30-E	
		40 m	JZSP-UCMP00-40-E	
		50 m	JZSP-UCMP00-50-E	

\*1. Flexible Cables are not available.

\*2. Refer to the following section for the flange specifications.

■ See Flange Specifications Page 175

## Flange Specifications

### ◆ SGMCS-□ □

Flange Specification Code (6th Digit)	Flange Location	Servo Motor Outer Diameter Code (3rd Digit)					
		B	C	D	E	M	N
1	Non-load side	✓	✓	✓	✓	–	–
	Load-side	–	–	–	–	✓	✓
3	Non-load side	–	–	–	–	✓	✓
4	Non-load side (with cable on side)	✓	✓	✓	✓	–	–

✓ Applicable models

**Direct Drive Servo Motors**

---

SGMCS (Small Capacity, Coreless or Medium Capacity, with Core)

# Linear Servo Motors

---

SGLG (Coreless Models) .....	178
SGLF (Models with F-type Iron Cores) .....	209
SGLT (Models with T-type Iron Cores) .....	234
Serial Converters Units .....	264
Recommended Linear Encoders .....	266

# SGLG (Coreless Models)

## Model Designations

### Moving Coil



**1st digit** Servo Motor Type

Code	Specification
G	Coreless model

**2nd digit** Moving Coil/Magnetic Way

Code	Specification
W	Moving Coil

**3rd+4th digits** Magnet Height

Code	Specification
30	30 mm
40	40 mm
60	60 mm
90	86 mm

**5th digit** Power Supply Voltage

Code	Specification
A	200 VAC

**6th+7th+8th digits** Length of Moving Coil

Code	Specification
050	50 mm
080	80 mm
140	140 mm
200	199 mm
253	252.5 mm
365	365 mm
370	367 mm
535	535 mm

**10th digit** Sensor Specification and Cooling Method

Code	Specifications		Applicable Models
	Polarity Sensor	Cooling Method	
None	None	Self-cooled	All models
C	None	Air-cooled	SGLGW
H	Yes	Air-cooled	-40A, -60A, -90A
P	Yes	Self-cooled	All models

**11th digit** Connector for Servo Motor Main Circuit Cable

Code	Specification	Applicable Models
None	Connector from Tyco Electronics Japan G.K.	All models
D	Connector from Interconnectron GmbH	SGLGW -30A, -40A, -60A

**9th digit** Design Revision Order

A, B...

■ Non Stock Items

Note: This information is provided to explain model numbers. It is not meant to imply that models are available for all combinations of codes.

### Magnetic Way



**1st digit** Servo Motor Type

(Same as for the Moving Coil.)

**2nd digit** Moving Coil/Magnetic Way

Code	Specification
M	Magnetic Way

**3rd+4th digits** Magnet Height

(Same as for the Moving Coil.)

**5th+6th+7th digits** Length of Magnetic Way

Code	Specification
090	90 mm
108	108 mm
216	216 mm
225	225 mm
252	252 mm
360	360 mm
405	405 mm
432	432 mm
450	450 mm
504	504 mm

**9th digit** Options

Code	Specification	Applicable Models
None	Standard-force	All models
-M	High-force	SGLGM-40, -60

■ Non Stock Items

**8th digit** Design Revision Order

A, B, C\*...

\* The SGLGM-40 and SGLGM-60 also have a CT code.

- C = Without mounting holes on the bottom
- CT = With mounting holes on the bottom

Note: This information is provided to explain model numbers. It is not meant to imply that models are available for all combinations of codes.

## Precautions on Moving Coils with Polarity Sensors



Note

When you use a Moving Coil with a Polarity Sensor, the Magnetic Way must cover the bottom of the polarity sensor. Refer to the example that shows the correct installation. When determining the length of the Moving Coil's stroke or the length of the Magnetic Way, consider the total length (L) of the Moving Coil and the polarity sensor. Refer to the following table.

### Correct Installation

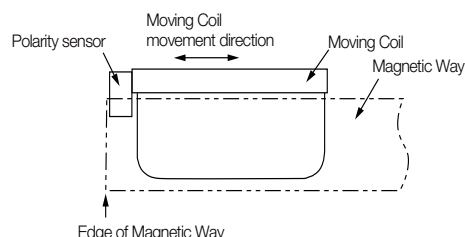

### Incorrect Installation

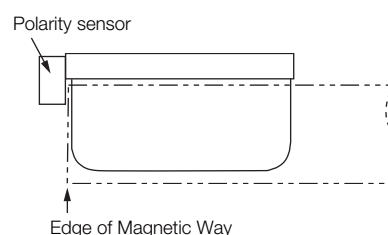

### ◆ Total Length of Moving Coil with Polarity Sensor

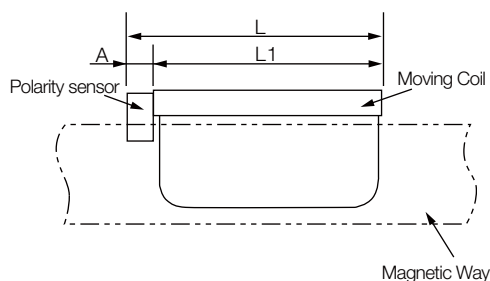

Moving Coil Model SGLGW-	Length of Moving Coil, L1 [mm]	Length of Polarity Sensor, A [mm]	Total Length, L [mm]
30A050□ P□	50	0	50
30A080□ P□	80	(Included in the length of Moving Coil.)	80
40A140□ H□ 40A140□ P□	140	16	156
40A253□ H□ 40A253□ P□	252.5		268.5
40A365□ H□ 40A365□ P□	365		381
60A140□ H□ 60A140□ P□	140	16	156
60A253□ H□ 60A253□ P□	252.5		268.5
60A365□ H□ 60A365□ P□	365		381
90A200□ H□ 90A200□ P□	199	0	199
90A370□ H□ 90A370□ P□	367	(Included in the length of Moving Coil.)	367
90A535□ H□ 90A535□ P□	535		535

## Specifications and Ratings

### Specifications: With Standard-Force Magnetic Way

Linear Servo Motor Moving Coil Model SGLGW-		30A		40A			60A			90A		
		050C	080C	140C	253C	365C	140C	253C	365C	200C	370C	535C
Time Rating		Continuous										
Thermal Class		B										
Insulation Resistance		500 VDC, 10 MΩmin.										
Withstand Voltage		1,500 VAC for 1 minute										
Excitation		Permanent magnet										
Cooling Method		Self-cooled or air-cooled (Only self-cooled models are available for the SGLGW-30A.)										
Protective Structure		IP00										
Environmental Condi- tions	Surrounding Air Tempera- ture	0°C to 40°C (with no freezing)										
	Surrounding Air Humidity	20% to 80% relative humidity (with no condensation)										
	Installation Site	<ul style="list-style-type: none"> <li>• Must be indoors and free of corrosive and explosive gases.</li> <li>• Must be well-ventilated and free of dust and moisture.</li> <li>• Must facilitate inspection and cleaning.</li> <li>• Must have an altitude of 1,000 m or less.</li> <li>• Must be free of strong magnetic fields.</li> </ul>										
Shock Resis- tance	Impact Accel- eration Rate	196 m/s <sup>2</sup>										
	Number of Impacts	2 times										
Vibration Resis- tance	Vibration Acceleration Rate	49 m/s <sup>2</sup> (the vibration resistance in three directions, vertical, side-to-side, and front-to-back)										



## Ratings: With Standard-Force Magnetic Way

Linear Servo Motor Moving Coil Model SGLGW-		30A		40A			60A			90A		
		050C	080C	140C	253C	365C	140C	253C	365C	200C	370C	535C
Rated Motor Speed (Reference Speed during Speed Control) <sup>*1</sup>	m/s	1.5	1.5	2.0	2.0	2.0	2.3	2.3	2.3	1.8	1.5	1.5
Maximum Speed <sup>*1</sup>	m/s	5.0	5.0	5.0	5.0	5.0	4.8	4.8	4.8	4.0	4.0	4.0
Rated Force <sup>*1, *2</sup>	N	12.5	25	47	93	140	70	140	210	325	550	750
Maximum Force <sup>*1</sup>	N	40	80	140	280	420	220	440	660	1300	2200	3000
Rated Current <sup>*1</sup>	Arms	0.51	0.79	0.80	1.6	2.4	1.2	2.2	3.3	4.4	7.5	10.2
Maximum Current <sup>*1</sup>	Arms	1.6	2.5	2.4	4.9	7.3	3.5	7.0	10.5	17.6	30.0	40.8
Moving Coil Mass	kg	0.10	0.15	0.34	0.60	0.87	0.42	0.76	1.1	2.2	3.6	4.9
Force Constant	N/Arms	26.4	33.9	61.5	61.5	61.5	66.6	66.6	66.6	78.0	78.0	78.0
BEMF Constant	Vrms/(m/s)/phase	8.80	11.3	20.5	20.5	20.5	22.2	22.2	22.2	26.0	26.0	26.0
Motor Constant	N/√W	3.66	5.63	7.79	11.0	13.5	11.1	15.7	19.2	26.0	36.8	45.0
Electrical Time Constant	ms	0.19	0.41	0.43	0.43	0.43	0.45	0.45	0.45	1.4	1.4	1.4
Mechanical Time Constant	ms	7.5	4.7	5.6	5.0	4.8	3.4	3.1	3.0	3.3	2.7	2.4
Thermal Resistance (with Heat Sink)	K/W	5.19	3.11	1.67	0.87	0.58	1.56	0.77	0.51	0.39	0.26	0.22
Thermal Resistance (without Heat Sink)	K/W	8.13	6.32	3.02	1.80	1.23	2.59	1.48	1.15	1.09	0.63	0.47
Magnetic Attraction	N	0	0	0	0	0	0	0	0	0	0	0
Combined Magnetic Way, SGLGM-		30□ □ □ A		40□ □ □ C□			60□ □ □ C□			90□ □ □ A		
Combined Serial Converter Unit, JZDP-□ □ □ □		250	251	252	253	254	258	259	260	264	265	266
Applicable SERVOPACKs	SGD7S-	R70A	R90A	R90A	1R6A	2R8A	1R6A	2R8A	5R5A	120A	180A	200A
	SGD7W-	1R6A	1R6A	1R6A	1R6A	2R8A	1R6A	2R8A	5R5A	-	-	-

\*1. These values are for operation in combination with a SERVOPACK when the temperature of the armature winding is 100°C. The values for other items are at 20°C. These are typical values.

\*2. The rated forces are the continuous allowable force values at a surrounding air temperature of 40°C with an aluminum heat sink of the dimensions given in the following table.

• Heat Sink Dimensions

- 200 mm × 300 mm × 12 mm: SGLGW-30A050C, -30A080C, -40A140C, and -60A140C
- 300 mm × 400 mm × 12 mm: SGLGW-40A253C and -60A253C
- 400 mm × 500 mm × 12 mm: SGLGW-40A365C and -60A365C
- 800 mm × 900 mm × 12 mm: SGLGW-90A200C, -90A370C, and -90A535C

## Force-Motor Speed Characteristics

**A** : Continuous duty zone ——— (solid lines): With three-phase 200-V input  
**B** : Intermittent duty zone - - - - - (dotted lines): With single-phase 200-V input

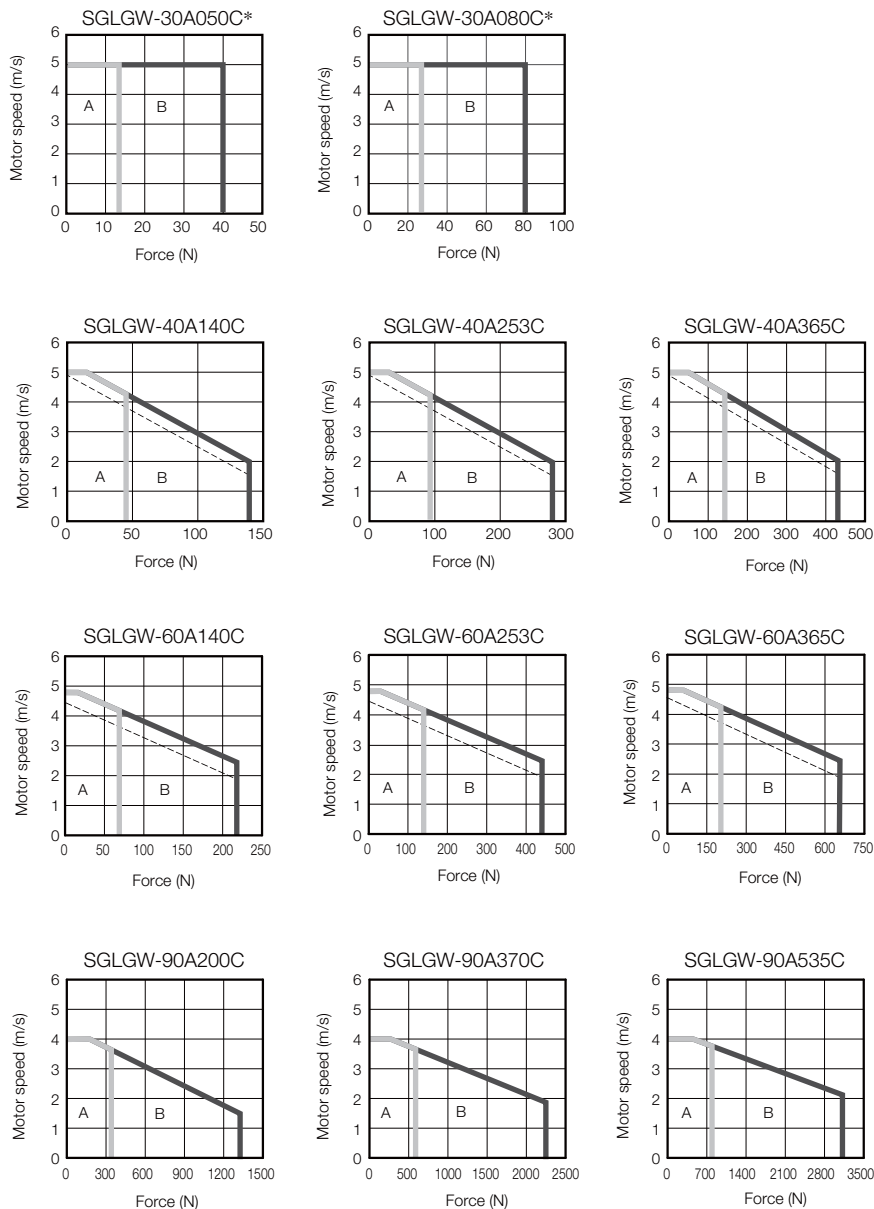

\* The characteristics are the same for three-phase 200 V and single-phase 200 V.

Note: 1. These values are for operation in combination with a SERVOPACK when the temperature of the armature winding is 100°C. These are typical values.

2. The characteristics in the intermittent duty zone depend on the power supply voltage.
3. If the effective force is within the allowable range for the rated force, the Servo Motor can be used within the intermittent duty zone.
4. If you use a Servo Motor Main Circuit Cable that exceeds 20 m, the intermittent duty zone in the torque-motor speed characteristics will become smaller because the voltage drop increases.

## Servo Motor Overload Protection Characteristics

The overload detection level is set for hot start conditions with a Servo Motor surrounding air temperature of 40°C.

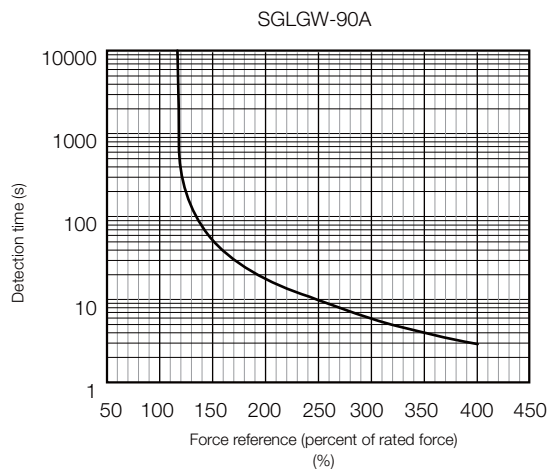
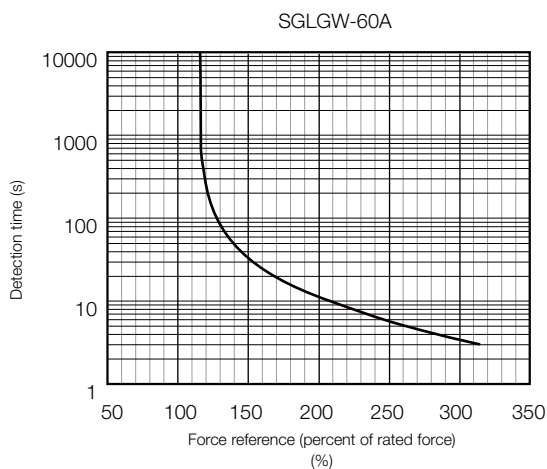
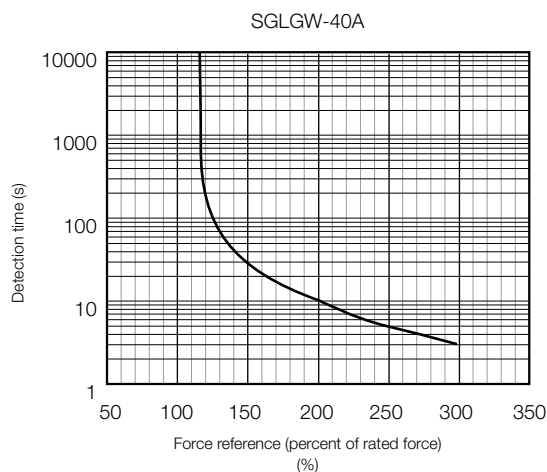
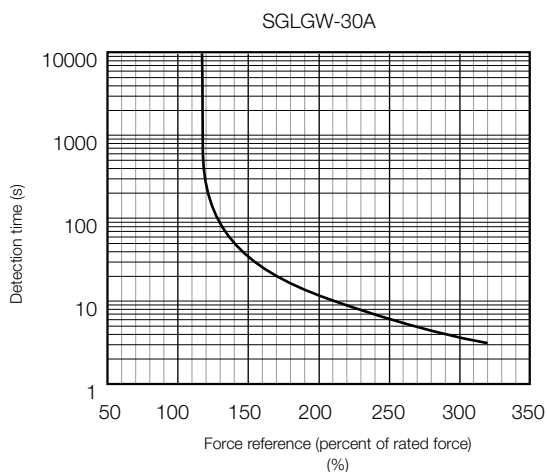

Note: The above overload protection characteristics do not mean that you can perform continuous duty operation with an output of 100% or higher. Use the Servo Motor so that the effective force remains within the continuous duty zone given in *Force-Motor Speed Characteristics* on page 182.

## Specifications: With High-Force Magnetic Way

Linear Servo Motor Moving Coil Model SGLGW-		40A			60A		
		140C	253C	365C	140C	253C	365C
Time Rating		Continuous					
Thermal Class		B					
Insulation Resistance		500 VDC, 10 MΩmin.					
Withstand Voltage		1,500 VAC for 1 minute					
Excitation		Permanent magnet					
Cooling Method		Self-cooled or air-cooled					
Protective Structure		IP00					
Environmental Conditions	Surrounding Air Temperature	0°C to 40°C (with no freezing)					
	Surrounding Air Humidity	20% to 80% relative humidity (with no condensation)					
	Installation Site	<ul style="list-style-type: none"> <li>• Must be indoors and free of corrosive and explosive gases.</li> <li>• Must be well-ventilated and free of dust and moisture.</li> <li>• Must facilitate inspection and cleaning.</li> <li>• Must have an altitude of 1,000 m or less.</li> <li>• Must be free of strong magnetic fields.</li> </ul>					
Shock Resistance	Impact Acceleration Rate	196 m/s <sup>2</sup>					
	Number of Impacts	2 times					
Vibration Resistance	Vibration Acceleration Rate	49 m/s <sup>2</sup> (the vibration resistance in three directions, vertical, side-to-side, and front-to-back)					

## Ratings: With High-Force Magnetic Way

Linear Servo Motor Moving Coil Model SGLGW-		40A			60A		
		140C	253C	365C	140C	253C	365C
Rated Motor Speed (Reference Speed during Speed Control) <sup>*1</sup>	m/s	1.0	1.0	1.0	1.0	1.0	1.0
Maximum Speed <sup>*1</sup>	m/s	4.2	4.2	4.2	4.2	4.2	4.2
Rated Force <sup>*1, *2</sup>	N	57	114	171	85	170	255
Maximum Force <sup>*1</sup>	N	230	460	690	360	720	1080
Rated Current <sup>*1</sup>	Arms	0.80	1.6	2.4	1.2	2.2	3.3
Maximum Current <sup>*1</sup>	Arms	3.2	6.5	9.7	5.0	10.0	14.9
Moving Coil Mass	kg	0.34	0.60	0.87	0.42	0.76	1.1
Force Constant	N/Arms	76.0	76.0	76.0	77.4	77.4	77.4
BEMF Constant	Vrms/(m/s)/ phase	25.3	25.3	25.3	25.8	25.8	25.8
Motor Constant	N/√W	9.62	13.6	16.7	12.9	18.2	22.3
Electrical Time Constant	ms	0.43	0.43	0.43	0.45	0.45	0.45
Mechanical Time Constant	ms	3.7	3.2	3.1	2.5	2.3	2.2
Thermal Resistance (with Heat Sink)	K/W	1.67	0.87	0.58	1.56	0.77	0.51
Thermal Resistance (without Heat Sink)	K/W	3.02	1.80	1.23	2.59	1.48	1.15
Magnetic Attraction	N	0	0	0	0	0	0
Combined Magnetic Way, SGLGM-		40□□□□M			60□□□□M		
Combined Serial Converter Unit, JZDP-□□□□		255	256	257	261	262	263
Applicable SERVOPACKs	SGD7S-	1R6A	2R8A	3R8A	1R6A	3R8A	7R6A
	SGD7W-	1R6A	2R8A	5R5A	1R6A	5R5A	7R6A

\*1. These values are for operation in combination with a SERVOPACK when the temperature of the armature winding is 100°C. The values for other items are at 20°C. These are typical values.

\*2. The rated forces are the continuous allowable force values at a surrounding air temperature of 40°C with an aluminum heat sink of the dimensions given in the following table.

- Heat Sink Dimensions
  - 200 mm × 300 mm × 12 mm: SGLGW-40A140C and -60A140C
  - 300 mm × 400 mm × 12 mm: SGLGW-40A253C and -60A253C
  - 400 mm × 500 mm × 12 mm: SGLGW-40A365C and -60A365C

## Force-Motor Speed Characteristics

**A** : Continuous duty zone ——— (solid lines): With three-phase 200-V input  
**B** : Intermittent duty zone - - - - - (dotted lines): With single-phase 200-V input

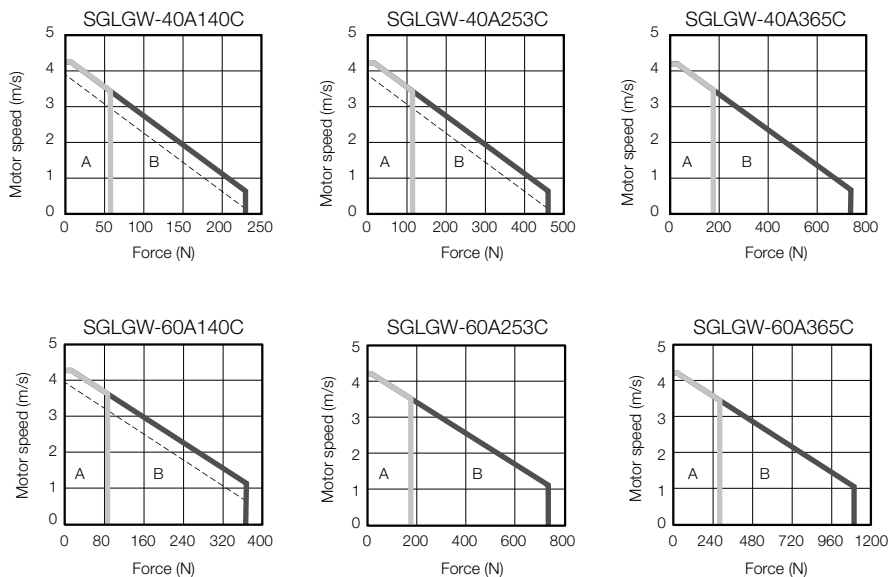

Note: 1. These values are for operation in combination with a SERVOPACK when the temperature of the armature winding is 100°C. These are typical values.

2. The characteristics in the intermittent duty zone depend on the power supply voltage.
3. If the effective force is within the allowable range for the rated force, the Servo Motor can be used within the intermittent duty zone.
4. If you use a Servo Motor Main Circuit Cable that exceeds 20 m, the intermittent duty zone in the torque-motor speed characteristics will become smaller because the voltage drop increases.

## Servo Motor Overload Protection Characteristics

The overload detection level is set for hot start conditions with a Servo Motor surrounding air temperature of 40°C.

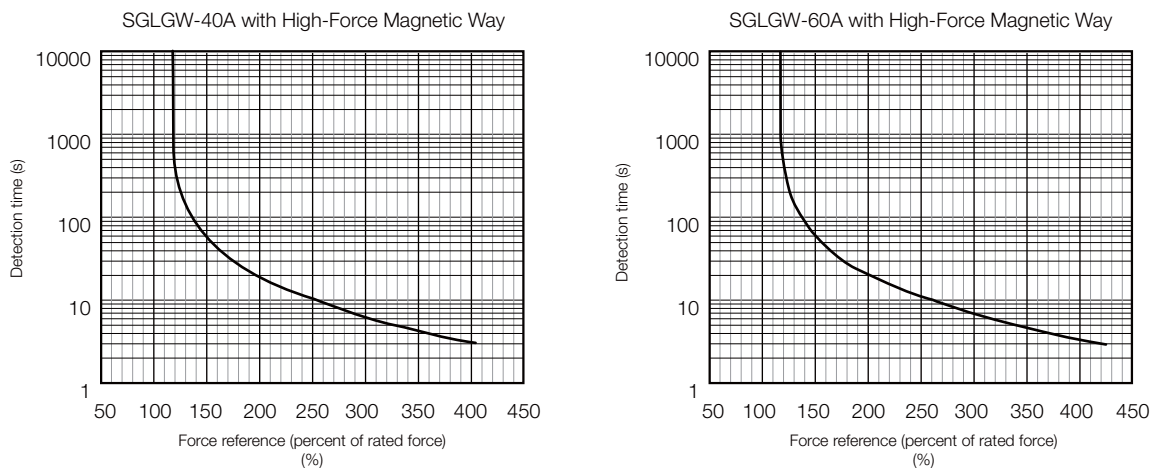

Note: The above overload protection characteristics do not mean that you can perform continuous duty operation with an output of 100% or higher. Use the Servo Motor so that the effective force remains within the continuous duty zone given in *Force-Motor Speed Characteristics* on page 186.

## External Dimensions

### SGLGW-30

#### ◆ Moving Coils: SGLGW-30A□□□C□

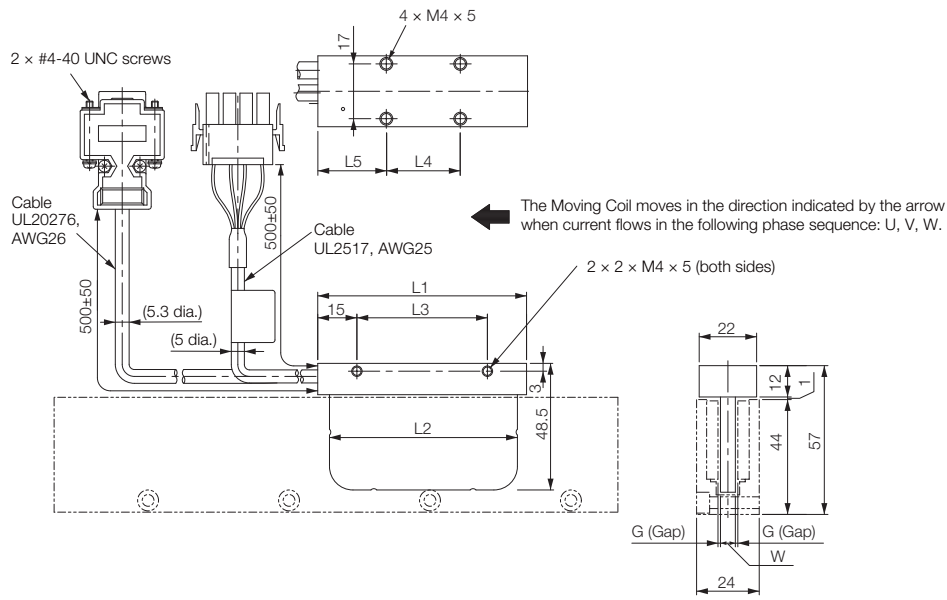

Moving Coil Model SGLGW-	L1	L2	L3	L4	L5	W	G (Gap)	Approx. Mass* [kg]
30A050C□	50	48	30	20	20	5.9	0.85	0.14
30A080C□	80	72	50	30	25	5.7	0.95	0.19

\* The mass is for a Moving Coil with a Polarity Sensor.

Refer to the following section for the connector specifications for the Sensor Cable and Servo Motor Main Circuit Cable.

☞ SGLGW-30A□□□C□ Moving Coils Page 200

◆ Moving Coils: SGLGW-30A□□□C□D

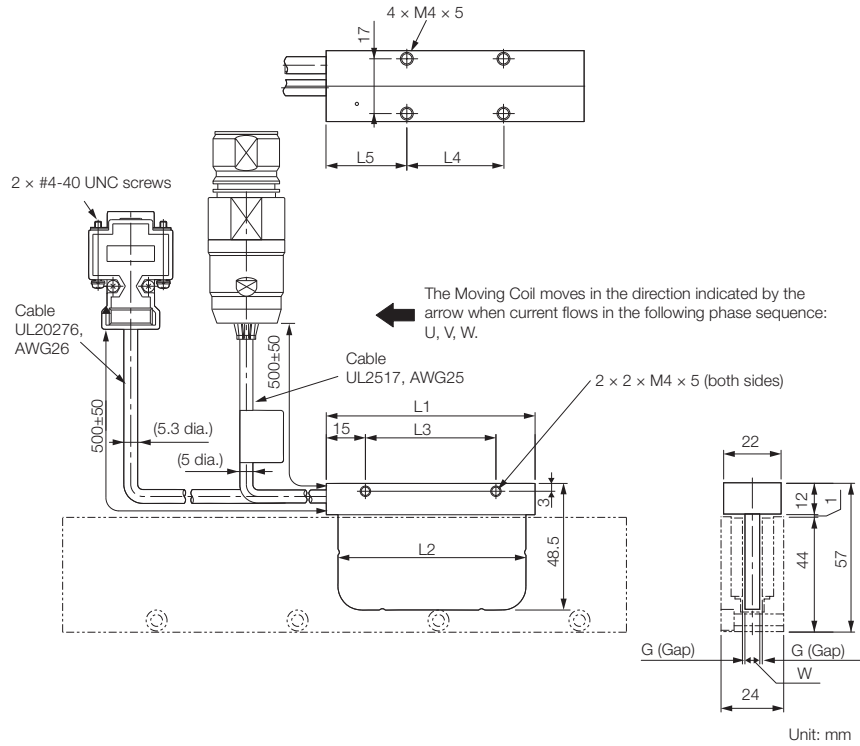

Moving Coil Model SGLGW-	L1	L2	L3	L4	L5	W	G (Gap)	Approx. Mass* [kg]
30A050C□D	50	48	30	20	20	5.9	0.85	0.14
30A080C□D	80	72	50	30	25	5.7	0.95	0.19

\* The mass is for a Moving Coil with a Polarity Sensor.  
Refer to the following section for the connector specifications for the Sensor Cable and Servo Motor Main Circuit Cable.



◆ Standard-Force Magnetic Ways: SGLGM-30□□□A

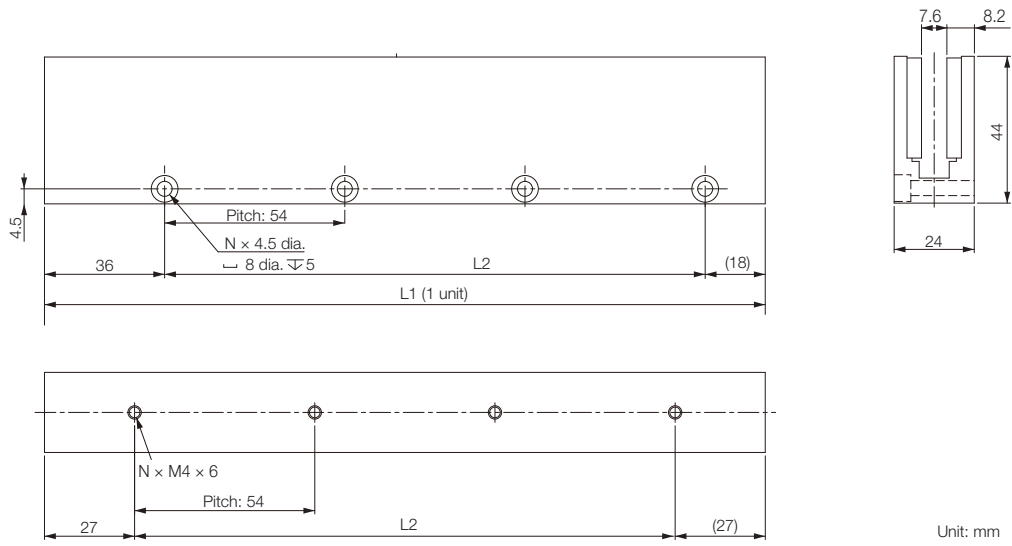

Magnetic Way Model SGLGM-	L1	L2	N	Approx. Mass [kg]
30108A	108 <sup>-0.1</sup> <sub>-0.1</sub>	54	2	0.6
30216A	216 <sup>-0.1</sup> <sub>-0.1</sub>	162	4	1.1
30432A	432 <sup>-0.1</sup> <sub>-0.1</sub>	378	8	2.3

## SGLGW-40

### ◆ Moving Coils: SGLGW-40A□□□C□

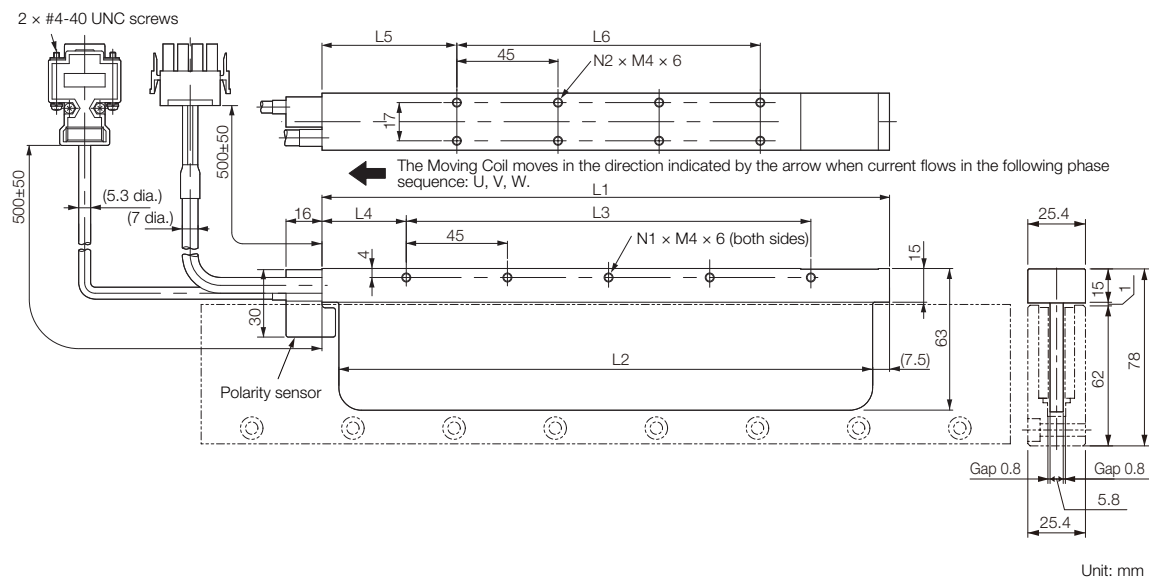

Moving Coil Model SGLGW-	L1	L2	L3	L4	L5	L6	N1	N2	Approx. Mass* [kg]
40A140C□	140	125	90	30	52.5	45	3	4	0.40
40A253C□	252.5	237.5	180	37.5	60	135	5	8	0.66
40A365C□	365	350	315	30	52.5	270	8	14	0.93

\* The mass is for a Moving Coil with a Polarity Sensor.

Refer to the following section for the connector specifications for the Sensor Cable and Servo Motor Main Circuit Cable.

☞ SGLGW-40A□□□C□ and -60A□□□C□ Moving Coils Page 202

◆ Moving Coils: SGLGW-40A□□□C□D

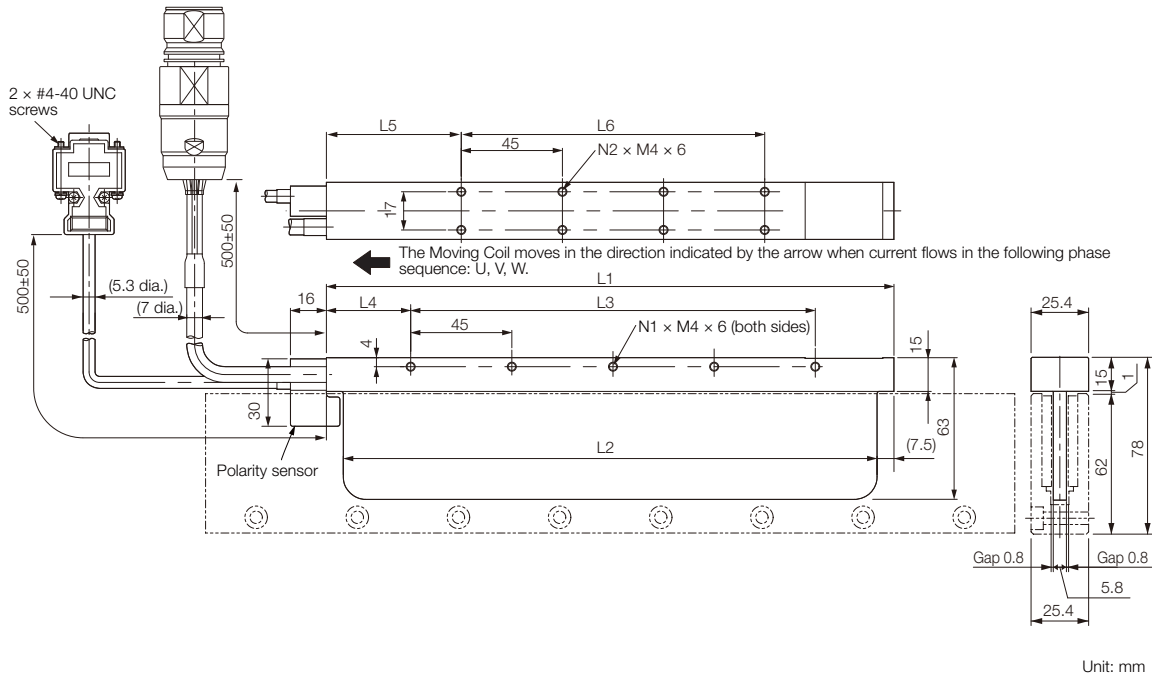

Moving Coil Model SGLGW-	L1	L2	L3	L4	L5	L6	N1	N2	Approx. Mass* [kg]
40A140C□D	140	125	90	30	52.5	45	3	4	0.40
40A253C□D	252.5	237.5	180	37.5	60	135	5	8	0.66
40A365C□D	365	350	315	30	52.5	270	8	14	0.93

\* The mass is for a Moving Coil with a Polarity Sensor.

Refer to the following section for the connector specifications for the Sensor Cable and Servo Motor Main Circuit Cable.

☞ SGLGW-40A□□□C□D and -60A□□□C□D Moving Coils Page 203

◆ Standard-Force Magnetic Ways:  
SGLGM-40□□□ C (without Mounting Holes on the Bottom)  
SGLGM-40□□□ CT (with Mounting Holes on the Bottom)

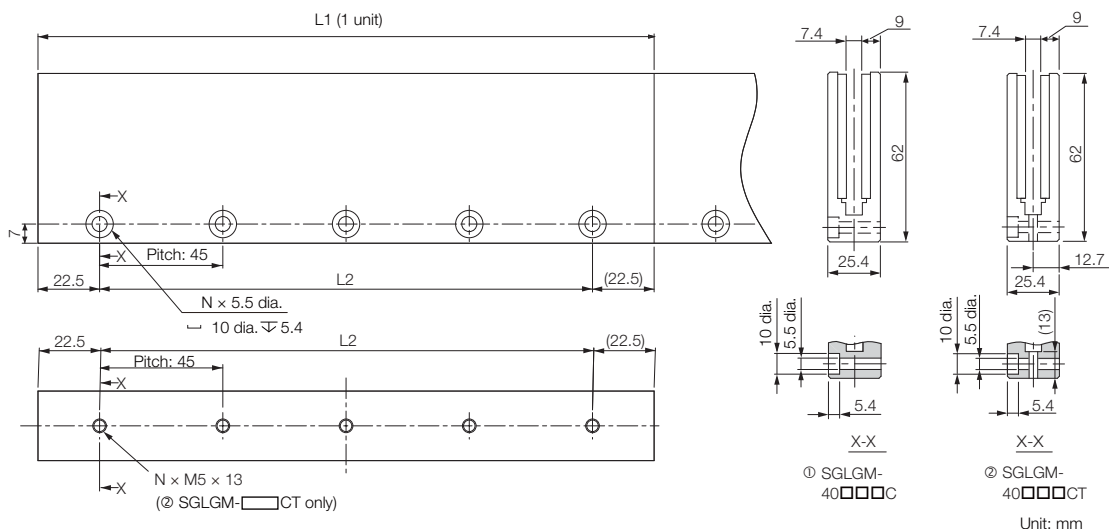

Type	Magnetic Way Model SGLGM-	L1	L2	N	Approx. Mass [kg]
Standard-Force	40090C or 40090CT	90 <sup>-0.1</sup> <sub>-0.3</sub>	45	2	0.8
	40225C or 40225CT	225 <sup>-0.1</sup> <sub>-0.3</sub>	180	5	2.0
	40360C or 40360CT	360 <sup>-0.1</sup> <sub>-0.3</sub>	315	8	3.1
	40405C or 40405CT	405 <sup>-0.1</sup> <sub>-0.3</sub>	360	9	3.5
	40450C or 40450CT	450 <sup>-0.1</sup> <sub>-0.3</sub>	405	10	3.9

◆ High-Force Magnetic Ways:  
SGLGM-40□□□ C-M (without Mounting Holes on the Bottom)  
SGLGM-40□□□ CT-M (with Mounting Holes on the Bottom)

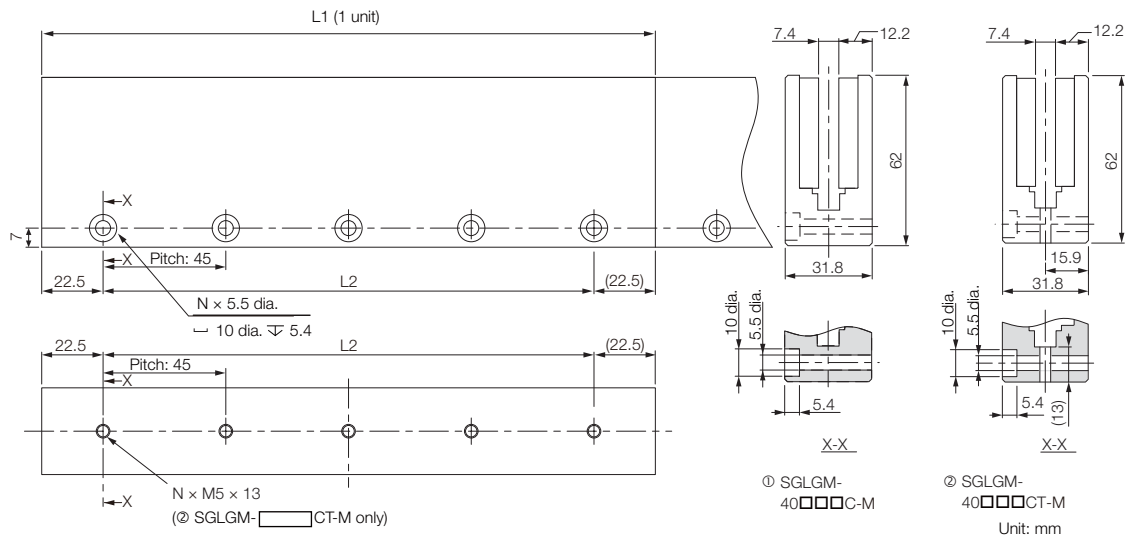

Type	Magnetic Way Model SGLGM-	L1	L2	N	Approx. Mass [kg]
High-Force	40090C-M or 40090CT-M	90 <sup>-0.1</sup> <sub>-0.3</sub>	45	2	1.0
	40225C-M or 40225CT-M	225 <sup>-0.1</sup> <sub>-0.3</sub>	180	5	2.6
	40360C-M or 40360CT-M	360 <sup>-0.1</sup> <sub>-0.3</sub>	315	8	4.1
	40405C-M or 40405CT-M	405 <sup>-0.1</sup> <sub>-0.3</sub>	360	9	4.6
	40450C-M or 40450CT-M	450 <sup>-0.1</sup> <sub>-0.3</sub>	405	10	5.1

## SGLGW-60

### ◆ Moving Coils: SGLGW-60A□□□C□

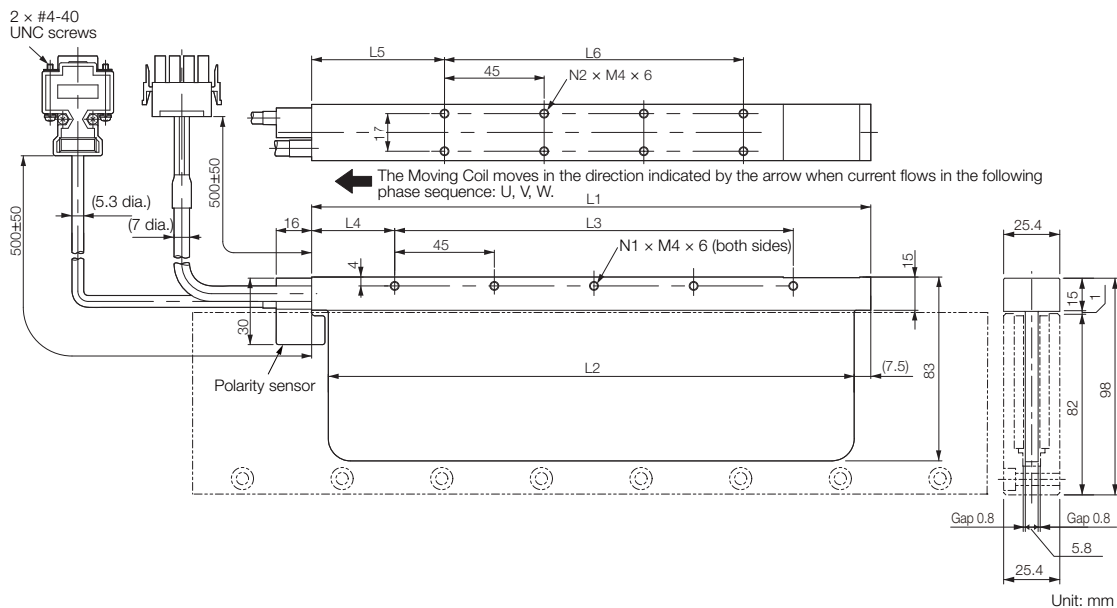

Moving Coil Model SGLGW-	L1	L2	L3	L4	L5	L6	N1	N2	Approx. Mass* [kg]
60A140C□	140	125	90	30	52.5	45	3	4	0.48
60A253C□	252.5	237.5	180	37.5	60	135	5	8	0.82
60A365C□	365	350	315	30	52.5	270	8	14	1.16

\* The mass is for a Moving Coil with a Polarity Sensor.

Refer to the following section for the connector specifications for the Sensor Cable and Servo Motor Main Circuit Cable.

☞ SGLGW-40A□□□C□ and -60A□□□C□ Moving Coils Page 202

◆ Moving Coils: SGLGW-60A□□□C□D

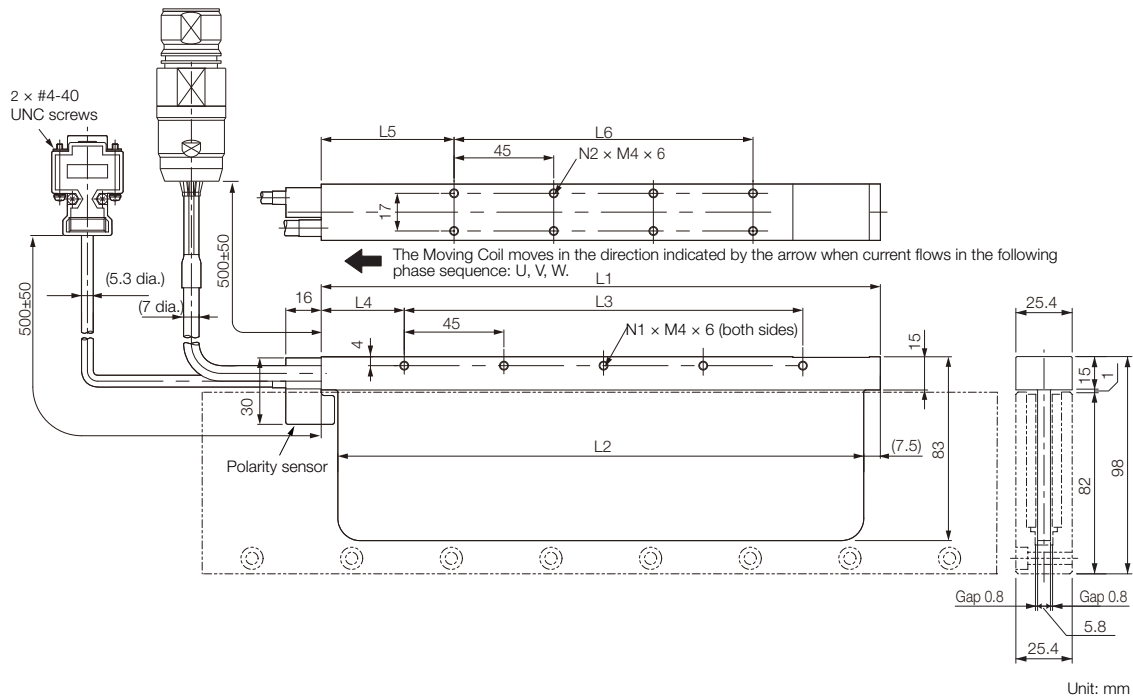

Moving Coil Model SGLGW-	L1	L2	L3	L4	L5	L6	N1	N2	Approx. Mass* [kg]
60A140C□D	140	125	90	30	52.5	45	3	4	0.48
60A253C□D	252.5	237.5	180	37.5	60	135	5	8	0.82
60A365C□D	365	350	315	30	52.5	270	8	14	1.16

\* The mass is for a Moving Coil with a Polarity Sensor.

Refer to the following section for the connector specifications for the Sensor Cable and Servo Motor Main Circuit Cable.

☞ SGLGW-40A□□□C□D and -60A□□□C□D Moving Coils Page 203

◆ **Standard-Force Magnetic Ways:**  
**SGLGM-60□□□ C (without Mounting Holes on the Bottom)**  
**SGLGM-60□□□ CT (with Mounting Holes on the Bottom)**

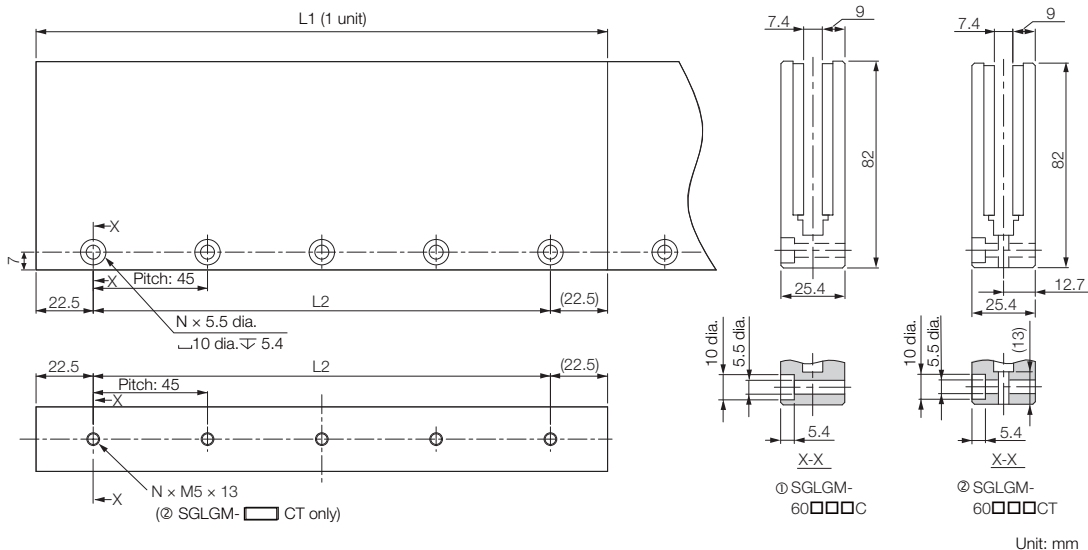

Type	Magnetic Way Model SGLGM-	L1	L2	N	Approx. Mass [kg]
Standard-Force	60090C or 60090CT	90 <sup>-0.1</sup> <sub>-0.3</sub>	45	2	1.1
	60225C or 60225CT	225 <sup>-0.1</sup> <sub>-0.3</sub>	180	5	2.6
	60360C or 60360CT	360 <sup>-0.1</sup> <sub>-0.3</sub>	315	8	4.1
	60405C or 60405CT	405 <sup>-0.1</sup> <sub>-0.3</sub>	360	9	4.6
	60450C or 60450CT	450 <sup>-0.1</sup> <sub>-0.3</sub>	405	10	5.1



◆ High-Force Magnetic Ways:  
SGLGM-60□□□ C-M (without Mounting Holes on the Bottom)  
SGLGM-60□□□ CT-M (with Mounting Holes on the Bottom)

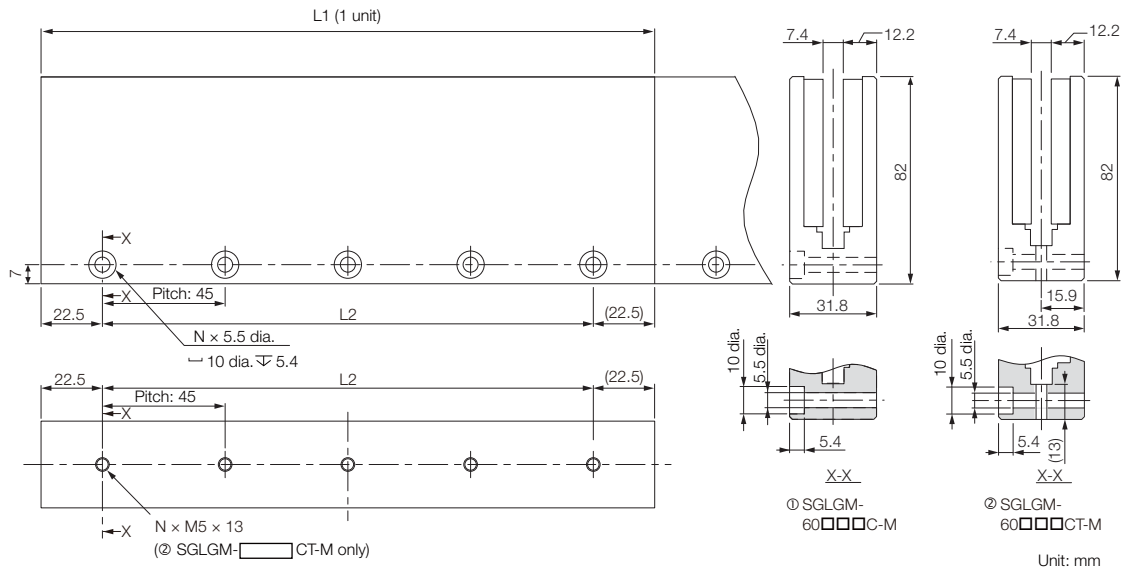

Type	Magnetic Way Model SGLGM-	L1	L2	N	Approx. Mass [kg]
High-Force	60090C-M or 60090CT-M	90 <sup>-0.1</sup> <sub>-0.3</sub>	45	2	1.3
	60225C-M or 60225CT-M	225 <sup>-0.1</sup> <sub>-0.3</sub>	180	5	3.3
	60360C-M or 60360CT-M	360 <sup>-0.1</sup> <sub>-0.3</sub>	315	8	5.2
	60405C-M or 60405CT-M	405 <sup>-0.1</sup> <sub>-0.3</sub>	360	9	5.9
	60450C-M or 60450CT-M	450 <sup>-0.1</sup> <sub>-0.3</sub>	405	10	6.6

## SGLGW-90

### ◆ Moving Coils: SGLGW-90A□□□C□

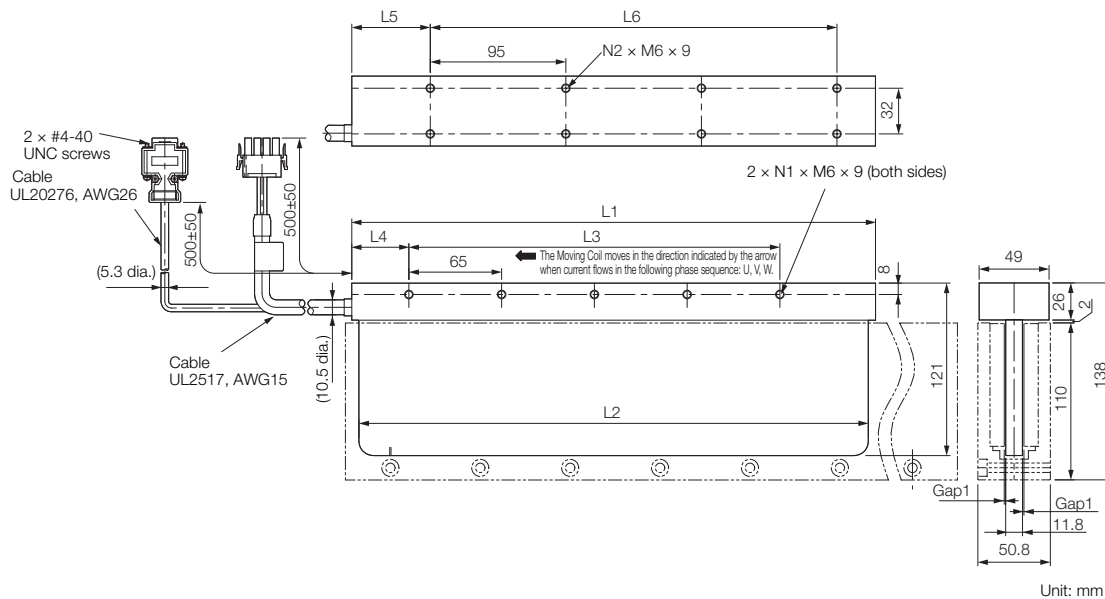

Moving Coil Model SGLGW-	L1	L2	L3	L4	L5	L6	N1	N2	Approx. Mass* [kg]
90A200C□	199	189	130	40	60	95	3	4	2.2
90A370C□	367	357	260	40	55	285	5	8	3.65
90A535C□	535	525	455	40	60	380	8	10	4.95

\* The mass is for a Moving Coil with a Polarity Sensor.

Refer to the following section for the connector specifications for the Sensor Cable and Servo Motor Main Circuit Cable.

☞ SGLGW-90A□□□C□ Moving Coils Page 204

◆ Standard-Force Magnetic Ways: SGLGM-90□□□A

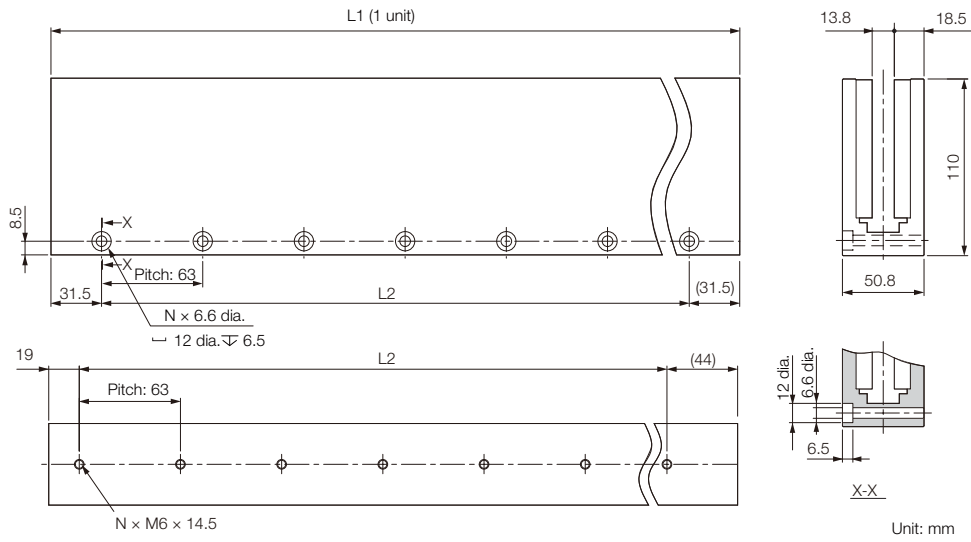

Magnetic Way Model SGLGM-	L1	L2	N	Approx. Mass [kg]
90252A	252 <sup>-0.1</sup> <sub>-0.3</sub>	189	4	7.3
90504A	504 <sup>-0.1</sup> <sub>-0.3</sub>	441	8	14.7

## Connector Specifications

### ◆ SGLGW-30A□□□C□ Moving Coils

- Servo Motor Connector



Plug: 350779-1  
Pins: 350924-1 or 770672-1  
Tyco Electronics Japan G.K.

Mating Connector  
Cap: 350780-1  
Socket: 350925-1 or 770673-1

- Polarity Sensor Connector



Pin connector: 17JE-23090-02 (D8C) -CG  
From DDK Ltd.

Mating Connector  
Socket connector: 17JE-13090-02 (D8C) A-CG  
Studs: 17L-002C or 17L-002C1

- Polarity Sensor Output Signal

The figure on the right shows the relationship between the Su, Sv, and Sw polarity sensor output signals and the inverse power of each motor phase Vu, Vv, and Vw when the Moving Coil moves in the direction indicated by the arrow in the dimensional drawings of the Moving Coil.

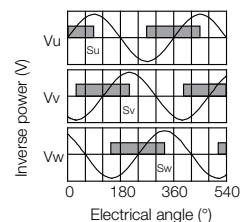

◆ SGLGW-30A□□□C□D Moving Coils

• Servo Motor Connector



Extension: SROC06JMSCN169  
Pins: 021.423.1020  
From Interconnectron GmbH

Mating Connector  
Plug: SPUC06KFSDN236  
Socket: 020.030.1020

• Polarity Sensor Connector



Pin connector: 17JE-23090-02 (D8C) -CG  
From DDK Ltd.

Mating Connector  
Socket connector: 17JE-13090-02 (D8C) A-CG  
Studs: 17L-002C or 17L-002C1

• Polarity Sensor Output Signal

The figure on the right shows the relationship between the Su, Sv, and Sw polarity sensor output signals and the inverse power of each motor phase Vu, Vv, and Vw when the Moving Coil moves in the direction indicated by the arrow in the dimensional drawings of the Moving Coil.

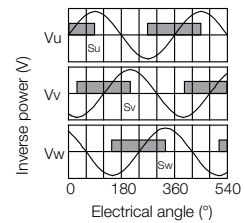

◆ SGLGW-40A□□□ C□ and -60A□□□ C□ Moving Coils

- Servo Motor Connector

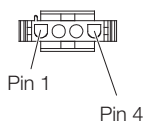

Plug: 350779-1  
Pins: 350561-3 or 350690-3 (No. 1 to 3)  
350654-1 or 350669-1 (No. 4)  
Tyco Electronics Japan G.K.

Mating Connector  
Cap: 350780-1  
Socket: 350570-3 or 350689-3

- Polarity Sensor Connector



Pin connector: 17JE-23090-02 (D8C) -CG  
From DDK Ltd.

Mating Connector  
Socket connector: 17JE-13090-02 (D8C) A-CG  
Studs: 17L-002C or 17L-002C1

- Polarity Sensor Output Signal

The figure on the right shows the relationship between the Su, Sv, and Sw polarity sensor output signals and the inverse power of each motor phase Vu, Vv, and Vw when the Moving Coil moves in the direction indicated by the arrow in the dimensional drawings of the Moving Coil.

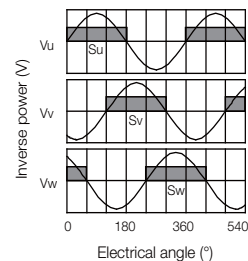

◆ SGLGW-40A□□□ C□ D and -60A□□□ C□ D Moving Coils

• Servo Motor Connector



Extension: SROC06JMSCN169  
Pins: 021.423.1020  
From Interconnectron GmbH

Mating Connector  
Plug: SPUC06KFSDN236  
Socket: 020.030.1020

• Polarity Sensor Connector



Pin connector: 17JE-23090-02 (D8C) -CG  
From DDK Ltd.

Mating Connector  
Socket connector: 17JE-13090-02 (D8C) A-CG  
Studs: 17L-002C or 17L-002C1

• Polarity Sensor Output Signal

The figure on the right shows the relationship between the Su, Sv, and Sw polarity sensor output signals and the inverse power of each motor phase Vu, Vv, and Vw when the Moving Coil moves in the direction indicated by the arrow in the dimensional drawings of the Moving Coil.

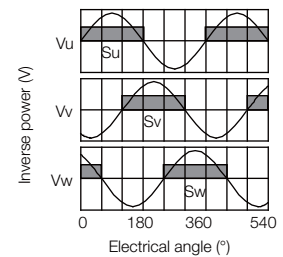

◆ SGLGW-90A□□□ C□ Moving Coils

• Servo Motor Connector

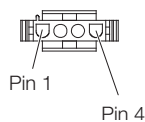

Plug: 350779-1  
Pins: 350218-3 or 350547-3 (No.1 to 3)  
350654-1 or 350669-1 (No. 4)  
Tyco Electronics Japan G.K.

Mating Connector  
Cap: 350780-1  
Socket: 350537-3 or 350550-3

• Polarity Sensor Connector



Pin connector: 17JE-23090-02 (D8C) -CG  
From DDK Ltd.

Mating Connector  
Socket connector: 17JE-13090-02 (D8C) A-CG  
Stud: 17L-002C or 17L-002C1

• Polarity Sensor Output Signal

The figure on the right shows the relationship between the Su, Sv, and Sw polarity sensor output signals and the inverse power of each motor phase Vu, Vv, and Vw when the Moving Coil moves in the direction indicated by the arrow in the dimensional drawings of the Moving Coil.

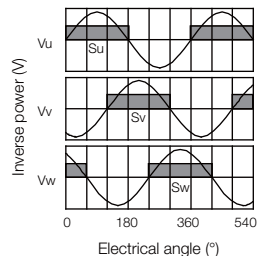



## Selecting Cables

### ◆ Cable Configurations

Example: SGLG Coreless Servo Motors

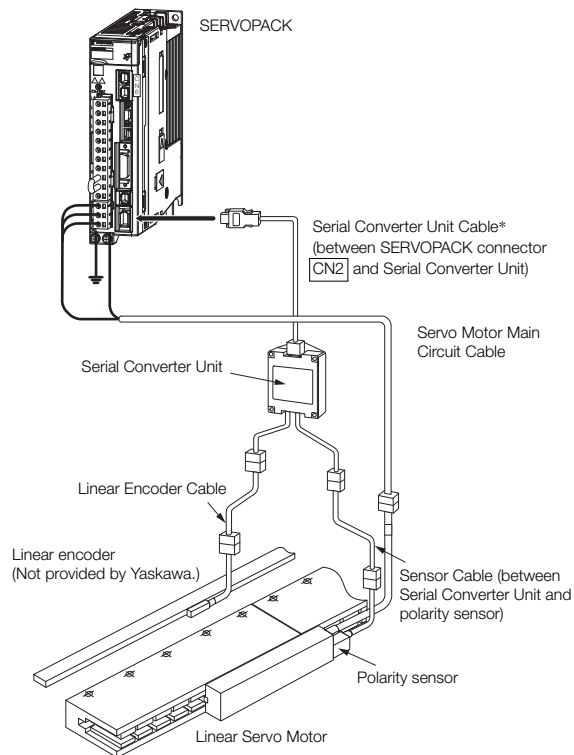

\* You can connect directly to an absolute linear encoder.

Note: 1. The above system configurations are for SGLG Coreless Servo Motors. Refer to the manual for the Linear Servo Motor for configurations with other models.

2. Refer to the following manual for the following information.

- Cable dimensional drawings and cable connection specifications
- Order numbers and specifications of individual connectors for cables
- Order numbers and specifications for wiring materials

📖  $\Sigma$ -7-Series AC Servo Drive Peripheral Device Selection Manual (Manual No.: SIEP S800001 32)

## Servo Motor Main Circuit Cables

Servo Motor Model	Length (L)	Order Number	Appearance
SGLGW-30A, -40A, -60A	1 m	JZSP-CLN11-01-E	
	3 m	JZSP-CLN11-03-E	
	5 m	JZSP-CLN11-05-E	
	10 m	JZSP-CLN11-10-E	
	15 m	JZSP-CLN11-15-E	
	20 m	JZSP-CLN11-20-E	
SGLGW-90A	1 m	JZSP-CLN21-01-E	
	3 m	JZSP-CLN21-03-E	
	5 m	JZSP-CLN21-05-E	
	10 m	JZSP-CLN21-10-E	
	15 m	JZSP-CLN21-15-E	
	20 m	JZSP-CLN21-20-E	
SGLGW-30A□□□□□□□□ -40A□□□□□□□□ -60A□□□□□□□□	1 m	JZSP-CLN14-01-E	
	3 m	JZSP-CLN14-03-E	
	5 m	JZSP-CLN14-05-E	
	10 m	JZSP-CLN14-10-E	
	15 m	JZSP-CLN14-15-E	
	20 m	JZSP-CLN14-20-E	

Note: Shaded model numbers are non-stock items

\*1. Connector from Tyco Electronics Japan G.K.

\*2. Connector from Interconnectron GmbH

\*3. A connector is not provided on the Linear Servo Motor end. Obtain a connector according to your specifications. Refer to the next page for information on connectors.

## Linear Encoder Cables

Name	Servo Motor Model	Length* (L)	Order Number	Appearance
For linear encoder from Renishaw PLC	All Models	1 m	JZSP-CLL00-01-E	
		3 m	JZSP-CLL00-03-E	
		5 m	JZSP-CLL00-05-E	
		10 m	JZSP-CLL00-10-E	
		15 m	JZSP-CLL00-15-E	
For linear encoder from Heidenhain Corporation		1 m	JZSP-CLL30-01-E	
		3 m	JZSP-CLL30-03-E	
		5 m	JZSP-CLL30-05-E	
		10 m	JZSP-CLL30-10-E	
		15 m	JZSP-CLL30-15-E	

\* When using a JZDP-J00□-□□□-E Serial Converter Unit, do not exceed a cable length of 3 m.

## Serial Converter Unit Cables

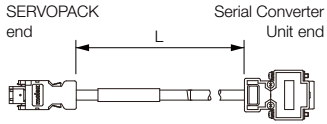
Servo Motor Model	Length (L)	Order Number	Appearance
All Models	1 m	JZSP-CLP70-01-E	
	3 m	JZSP-CLP70-03-E	
	5 m	JZSP-CLP70-05-E	
	10 m	JZSP-CLP70-10-E	
	15 m	JZSP-CLP70-15-E	
	20 m	JZSP-CLP70-20-E	

## Sensor Cables

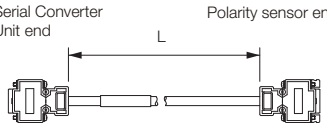
Servo Motor Model	Length (L)	Order Number	Appearance
SGLGW-□□ A	1 m	JZSP-CLL10-01-E	
	3 m	JZSP-CLL10-03-E	
	5 m	JZSP-CLL10-05-E	
	10 m	JZSP-CLL10-10-E	
	15 m	JZSP-CLL10-15-E	



# SGLF (Models with F-type Iron Cores)

## Model Designations

### SGLFW Models

#### ◆ Moving Coil

S G L F W - 20 A 090 A P □

Linear  $\Sigma$  Series  
Linear Servo Motors

1st digit

2nd digit

3rd+4th digits

5th digit

6th+7th+8th digits

9th digit

10th digit

11th digit

1st digit Servo Motor Type

Code	Specification
F	With F-type iron core

5th digit Voltage

Code	Specification
A	200 VAC

10th digit Sensor Specification

Code	Specification
P	With polarity sensor
None	Without polarity sensor

2nd digit Moving Coil/Magnetic Way

Code	Specification
W	Moving Coil

6th+7th+8th digits Length of Moving Coil

Code	Specification
090	91 mm
120	127 mm
200	215 mm
230	235 mm
380	395 mm

11th digit Connector for Servo Motor Main Circuit Cable

Code	Specification	Applicable Models
None	Connector from Tyco Electronics Japan G.K.	All models
D	Connector from Interconnectron GmbH	SGLFW-35, -50, -1Z□200B

3rd+4th digits Magnet Height

Code	Specification
20	20 mm
35	36 mm
50	47.5 mm
1Z	95 mm

9th digit Design Revision Order

A, B ...

■ Non Stock Items

Note: This information is provided to explain model numbers. It is not meant to imply that models are available for all combinations of codes.

#### ◆ Magnetic Way

S G L F M - 20 324 A □

Linear  $\Sigma$  Series  
Linear Servo Motors

1st digit

2nd digit

3rd+4th digits

5th+6th+7th digits

8th digit

9th digit

1st digit Servo Motor Type

(Same as for the Moving Coil.)

5th+6th+7th digits Length of Magnetic Way

Code	Specification
324	324 mm
405	405 mm
540	540 mm
675	675 mm
756	756 mm
945	945 mm

9th digit Options

Code	Specification
None	Without options
C	With magnet cover

2nd digit Moving Coil/Magnetic Way

Code	Specification
M	Magnetic Way

■ Non Stock Items

3rd+4th digits Magnet Height

(Same as for the Moving Coil.)

8th digit Design Revision Order

A, B ...

## Precautions on Moving Coils with Polarity Sensors



**Note** When you use a Moving Coil with a Polarity Sensor, the Magnetic Way must cover the bottom of the polarity sensor. Refer to the example that shows the correct installation. When determining the length of the Moving Coil's stroke or the length of the Magnetic Way, consider the total length (L) of the Moving Coil and the polarity sensor. Refer to the following table.

### Correct Installation

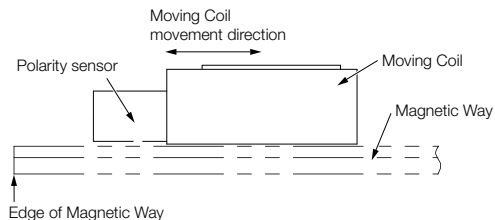

### Incorrect Installation

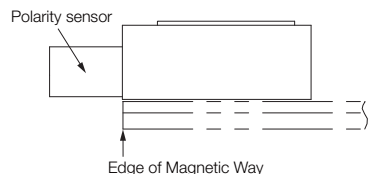

### ◆ Total Length of Moving Coil with Polarity Sensor

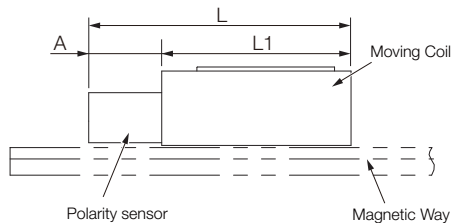

Moving Coil Model SGLFW-	Length of Moving Coil, L1 [mm]	Length of Polarity Sensor, A [mm]	Total Length, L [mm]
20A090AP	91	22	113
20A120AP	127		149
35A120AP□	127	22	149
35A230AP□	235		257
50A200BP□	215	22	237
50A380BP□	395		417
1ZA200BP□	215	22	237
1ZA380BP	395		417

## Specifications and Ratings: SGLFW Models

### Specifications

Linear Servo Motor Moving Coil Model SGLFW-		20A		35A		50A		1ZA	
		090A	120A	120A	230A	200B	380B	200B	380B
Time Rating		Continuous							
Thermal Class		B							
Insulation Resistance		500 VDC, 10 M $\Omega$ min.							
Withstand Voltage		1,500 VAC for 1 minute							
Excitation		Permanent magnet							
Cooling Method		Self-cooled							
Protective Structure		IP00							
Environmental Conditions	Surrounding Air Temperature	0°C to 40°C (with no freezing)							
	Surrounding Air Humidity	20% to 80% relative humidity (with no condensation)							
	Installation Site	<ul style="list-style-type: none"> <li>• Must be indoors and free of corrosive and explosive gases.</li> <li>• Must be well-ventilated and free of dust and moisture.</li> <li>• Must facilitate inspection and cleaning.</li> <li>• Must have an altitude of 1,000 m or less.</li> <li>• Must be free of strong magnetic fields.</li> </ul>							
Shock Resistance	Impact Acceleration Rate	196 m/s <sup>2</sup>							
	Number of Impacts	2 times							
Vibration Resistance	Vibration Acceleration Rate	49 m/s <sup>2</sup> (the vibration resistance in three directions, vertical, side-to-side, and front-to-back)							

## Linear Servo Motors

SGLF (Models with F-type Iron Cores)

## Ratings

Linear Servo Motor Moving Coil Model SGLFW-		20A		35A		50A		1ZA	
		090A	120A	120A	230A	200B	380B	200B	380B
Rated Motor Speed (Reference Speed during Speed Control) <sup>*1</sup>	m/s	5.0	3.5	2.5	3.0	1.5	1.5	1.5	1.5
Maximum Speed <sup>*1</sup>	m/s	5.0	5.0	5.0	5.0	5.0	5.0	4.9	4.9
Rated Force <sup>*1, *2</sup>	N	25	40	80	160	280	560	560	1120
Maximum Force <sup>*1</sup>	N	86	125	220	440	600	1200	1200	2400
Rated Current <sup>*1</sup>	Arms	0.70	0.80	1.4	2.8	5.0	10.0	8.7	17.5
Maximum Current <sup>*1</sup>	Arms	3.0	2.9	4.4	8.8	12.4	25.0	21.6	43.6
Moving Coil Mass	kg	0.70	0.90	1.3	2.3	3.5	6.9	6.4	12
Force Constant	N/Arms	36.0	54.0	62.4	62.4	60.2	60.2	69.0	69.0
BEMF Constant	Vrms/(m/s)/ phase	12.0	18.0	20.8	20.8	20.1	20.1	23.0	23.0
Motor Constant	N/ $\sqrt{W}$	7.95	9.81	14.4	20.4	34.3	48.5	52.4	74.0
Electrical Time Constant	ms	3.2	3.3	3.6	3.6	16	16	18	18
Mechanical Time Constant	ms	11	9.4	6.3	5.5	3.0	2.9	2.3	2.1
Thermal Resistance (with Heat Sink)	K/W	4.35	3.19	1.57	0.96	0.56	0.38	0.47	0.20
Thermal Resistance (without Heat Sink)	K/W	7.69	5.02	4.10	1.94	1.65	0.95	1.30	0.73
Magnetic Attraction	N	310	460	810	1590	1650	3260	3300	6520
Combined Magnetic Way, SGLFM-		20□□□A□		35□□□A□		35□□□A□		35□□□A□	
Combined Serial Converter Unit, JZDP-□□□□		017	018	019	020	181	182	183	184
Applicable SERVOPACKs	SGD7S-	1R6A	1R6A	1R6A	3R8A	5R5A	120A	120A	200A
	SGD7W-	1R6A	1R6A	1R6A	5R5A	5R5A	-	-	-

\*1. These values are for operation in combination with a SERVOPACK when the temperature of the armature winding is 100°C. The values for other items are at 20°C. These are typical values.

\*2. The rated forces are the continuous allowable force values at a surrounding air temperature of 40°C with an aluminum heat sink of the dimensions given in the following table.

- Heat Sink Dimensions

- 125 mm × 125 mm × 13 mm: SGLFW-20A090A and -20A120A
- 254 mm × 254 mm × 25 mm: SGLFW-35A120A and -35A230A
- 400 mm × 500 mm × 40 mm: SGLFW-50A200B, 50A380B, and -1ZA200B
- 600 mm × 762 mm × 50 mm: SGLFW-1ZA380B



## Force-Motor Speed Characteristics

- A : Continuous duty zone ——— (solid lines): With three-phase 200-V input  
B : Intermittent duty zone - - - - - (dotted lines): With single-phase 200-V input

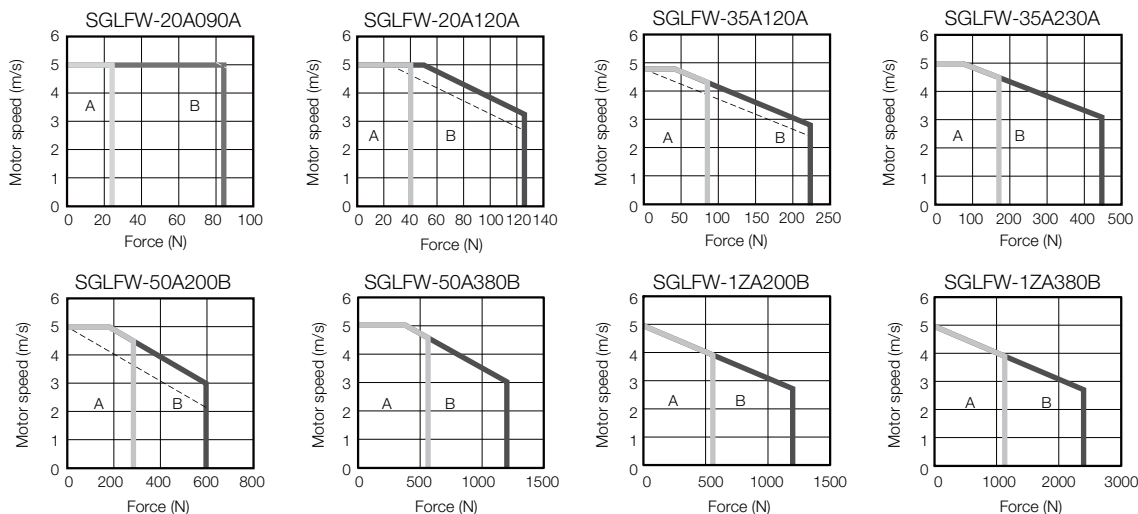

- Note: 1. These values are for operation in combination with a SERVOPACK when the temperature of the armature winding is 100°C. These are typical values.
2. The characteristics in the intermittent duty zone depend on the power supply voltage.
3. If the effective force is within the allowable range for the rated force, the Servo Motor can be used within the intermittent duty zone.
4. If you use a Servo Motor Main Circuit Cable that exceeds 20 m, the intermittent duty zone in the torque-motor speed characteristics will become smaller because the voltage drop increases.

## Servo Motor Overload Protection Characteristics

The overload detection level is set for hot start conditions with a Servo Motor surrounding air temperature of 40°C.

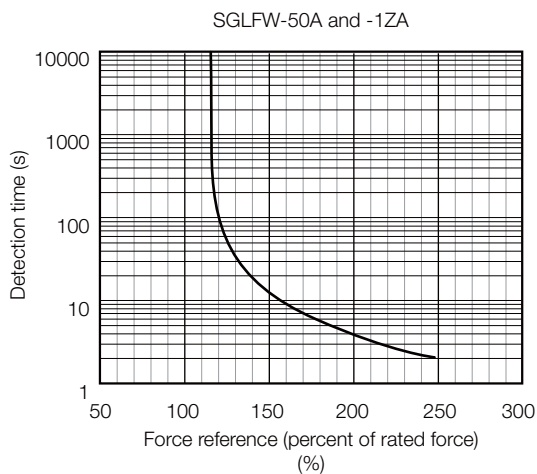
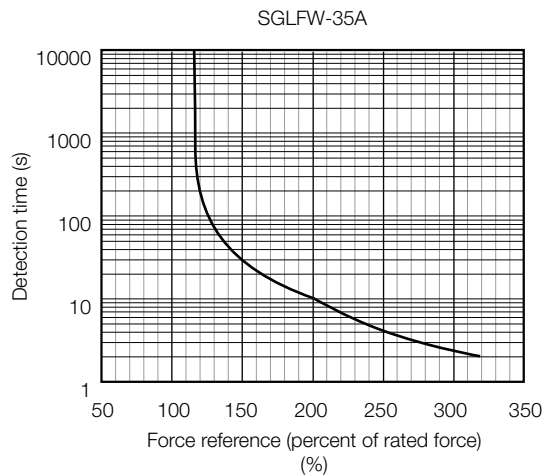
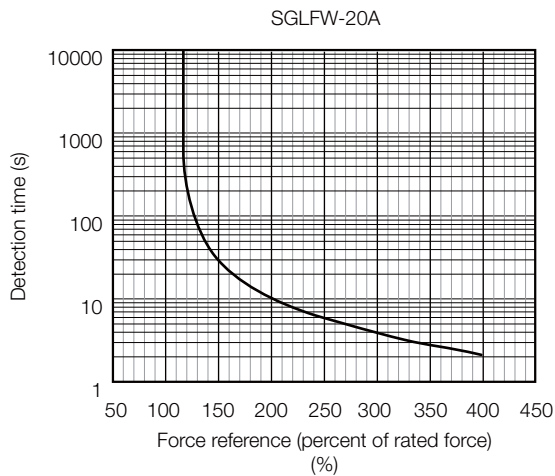

Note: The above overload protection characteristics do not mean that you can perform continuous duty operation with an output of 100% or higher. Use the Servo Motor so that the effective force remains within the continuous duty zone given in *Force-Motor Speed Characteristics* on page 213.

# External Dimensions

## SGLFW-20

### ◆ Moving Coils: SGLFW-20A□□□A□

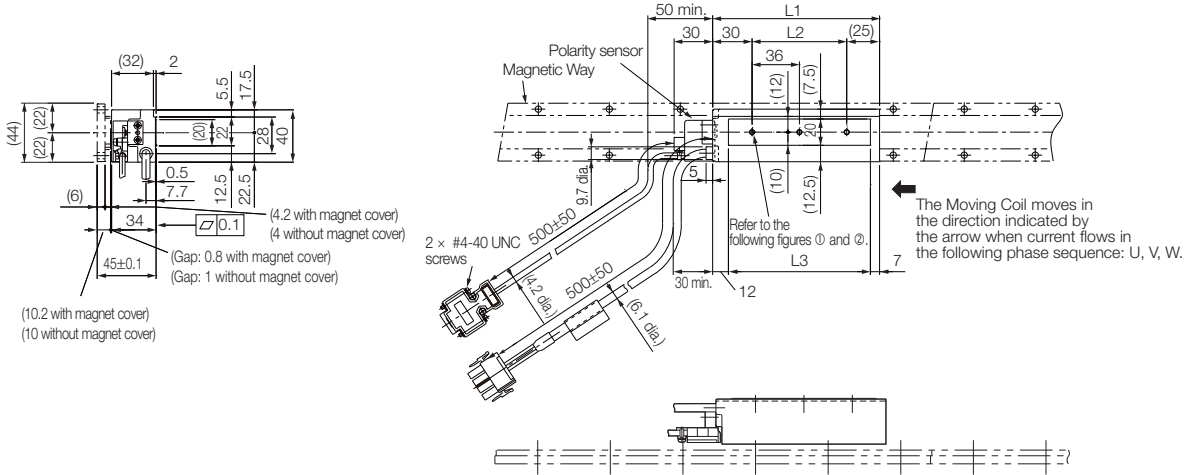

① SGLFW-20A090A□

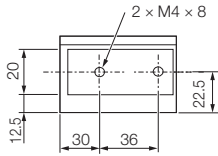

② SGLFW-20A120A□

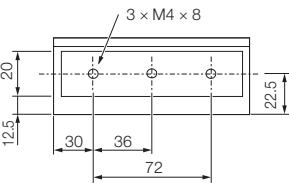

Unit: mm

Moving Coil Model SGLFW-	L1	L2	L3	Approx. Mass [kg]
20A090A□	91	36	72	0.7
20A120A□	127	72	108	0.9

Note: The above dimensional drawing gives the dimensions for both models with polarity sensors and models without polarity sensors.  
Refer to the following section for the connector specifications for the Sensor Cable and Servo Motor Main Circuit Cable.  
☞ SGLFW-20A□□□A□ and -35A□□□A□ Moving Coils (page 226)

## Linear Servo Motors

SGLF (Models with F-type Iron Cores)

### ◆ Magnetic Ways: SGLFM-20□□□A

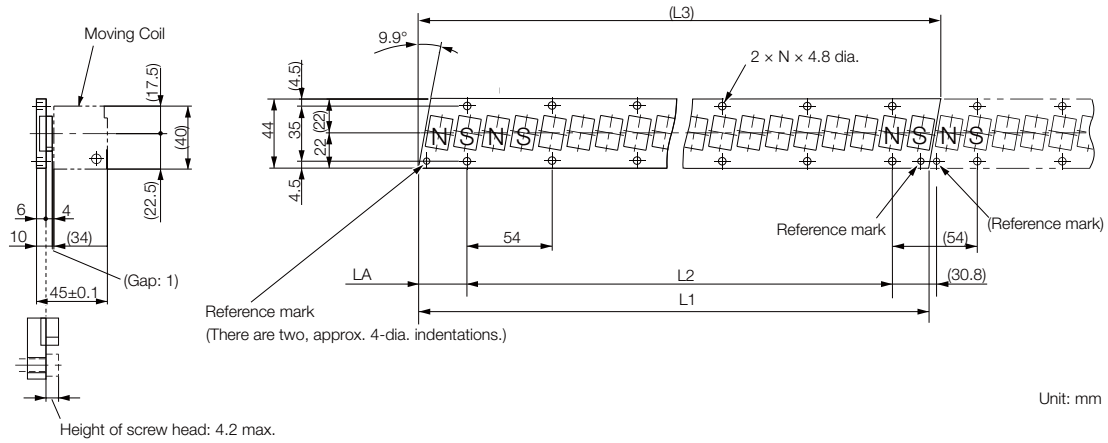

Mounting Section Details

Note: More than one Magnetic Way can be connected. Connect the Magnetic Ways so that the reference marks on them are aligned in the same direction as shown in the figure.

Magnetic Way Model SGLFM-	L1	L2	(L3)	LA	N	Approx. Mass [kg]
20324A	324 <sup>+0.1</sup> <sub>-0.3</sub>	270 (54 × 5)	(331.6)	30.8 <sup>0</sup> <sub>-0.2</sub>	6	0.9
20540A	540 <sup>+0.1</sup> <sub>-0.3</sub>	486 (54 × 9)	(547.6)	30.8 <sup>0</sup> <sub>-0.2</sub>	10	1.4
20756A	756 <sup>+0.1</sup> <sub>-0.3</sub>	702 (54 × 13)	(763.6)	30.8 <sup>0</sup> <sub>-0.2</sub>	14	2

# SGLFW-35

◆ Moving Coils: SGLFW-35A□□□A□

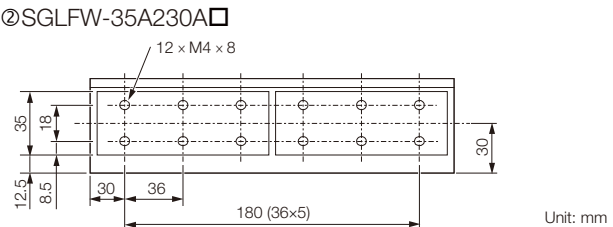
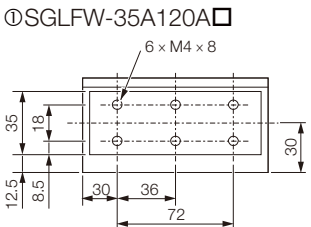
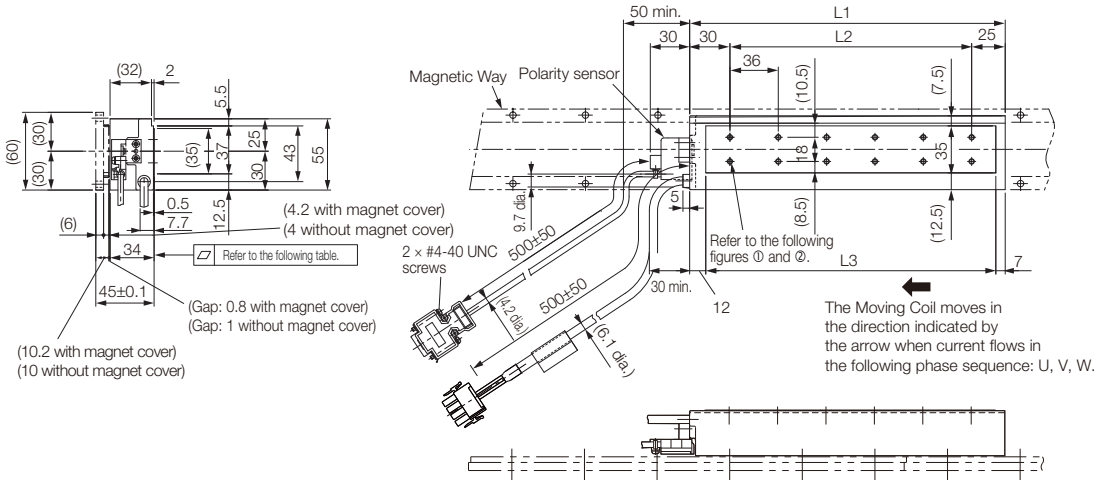

Moving Coil Model SGLFW-	L1	L2	L3	Approx. Mass [kg]
35A120A□	127	72	108	1.3
35A230A□	235	180	216	2.3

Note: The above dimensional drawing gives the dimensions for both models with polarity sensors and models without polarity sensors.  
 Refer to the following section for the connector specifications for the Sensor Cable and Servo Motor Main Circuit Cable.  
 SGLFW-20A□□□A□ and -35A□□□A□ Moving Coils (page 226)

Linear Servo Motors

◆ **Moving Coils: SGLFW-35A□□□A□D**

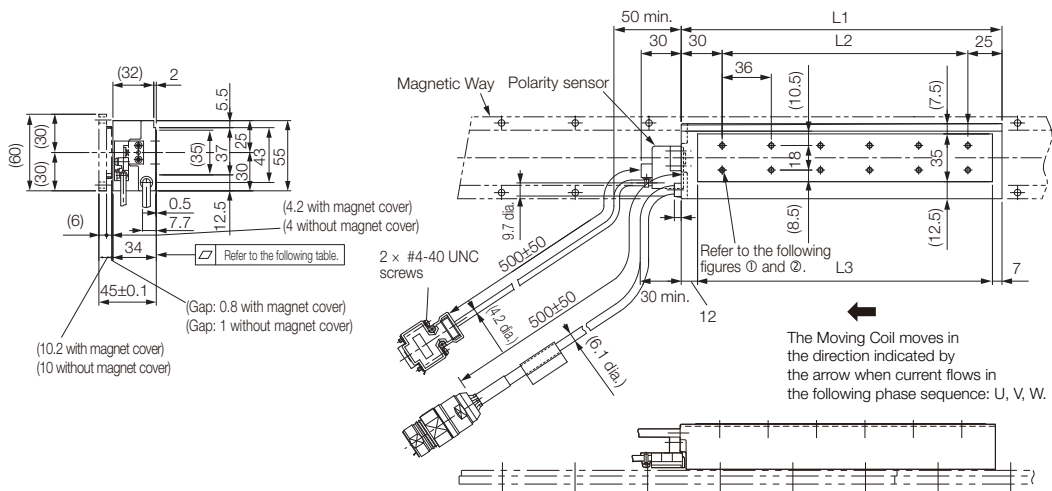

① SGLFW-35A120A□D

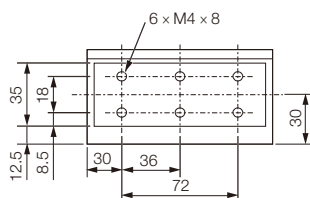

② SGLFW-35A230A□D

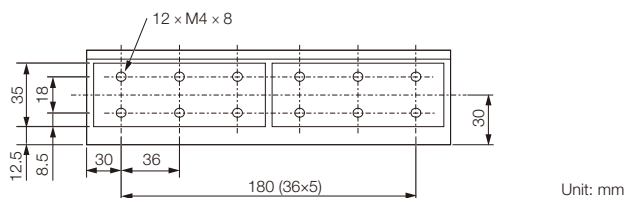

Moving Coil Model SGLFW-	L1	L2	L3	Approx. Mass [kg]
35A120A□D	127	72	108	1.3
35A230A□D	235	180	216	2.3

Note: The above dimensional drawing gives the dimensions for both models with polarity sensors and models without polarity sensors.  
 Refer to the following section for the connector specifications for the Sensor Cable and Servo Motor Main Circuit Cable.  
 📖 SGLFW-35A□□□A□D and -50A□□□B□D Moving Coils (page 227)

◆ **Magnetic Ways: SGLFM-35□□□A**

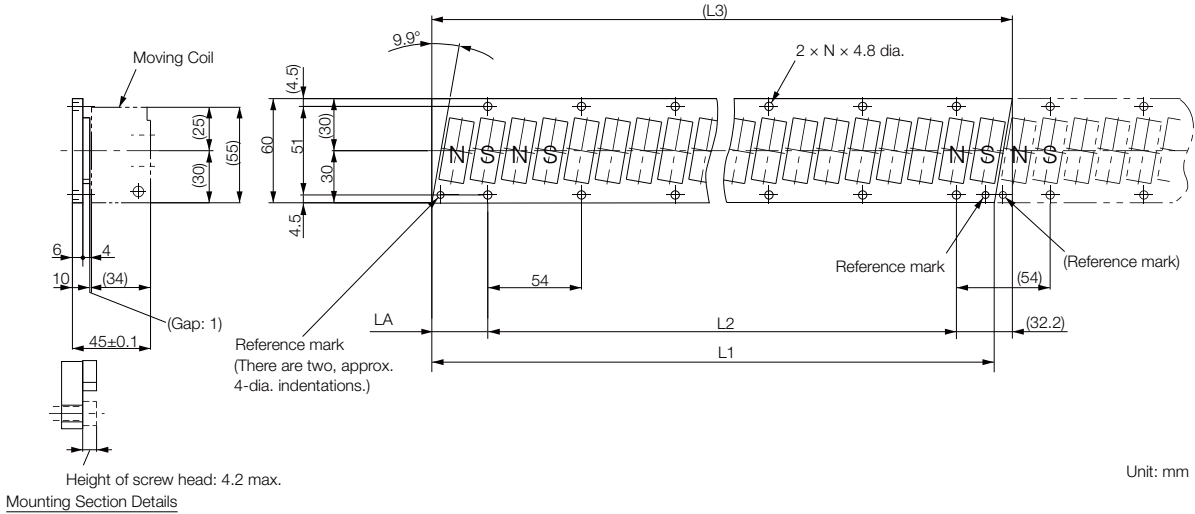

Note: More than one Magnetic Way can be connected. Connect the Magnetic Ways so that the reference marks on them are aligned in the same direction as shown in the figure.

Magnetic Way Model SGLFM-	L1	L2	(L3)	LA	N	Approx. Mass [kg]
35324A	324 <sup>-0.1</sup> <sub>-0.3</sub>	270 (54 × 5)	(334.4)	32.2 <sup>0</sup> <sub>-0.2</sub>	6	1.2
35540A	540 <sup>-0.1</sup> <sub>-0.3</sub>	486 (54 × 9)	(550.4)	32.2 <sup>0</sup> <sub>-0.2</sub>	10	2
35756A	756 <sup>-0.1</sup> <sub>-0.3</sub>	702 (54 × 13)	(766.4)	32.2 <sup>0</sup> <sub>-0.2</sub>	14	2.9

## SGLFW-50

### ◆ Moving Coils: SGLFW-50A□□□B□

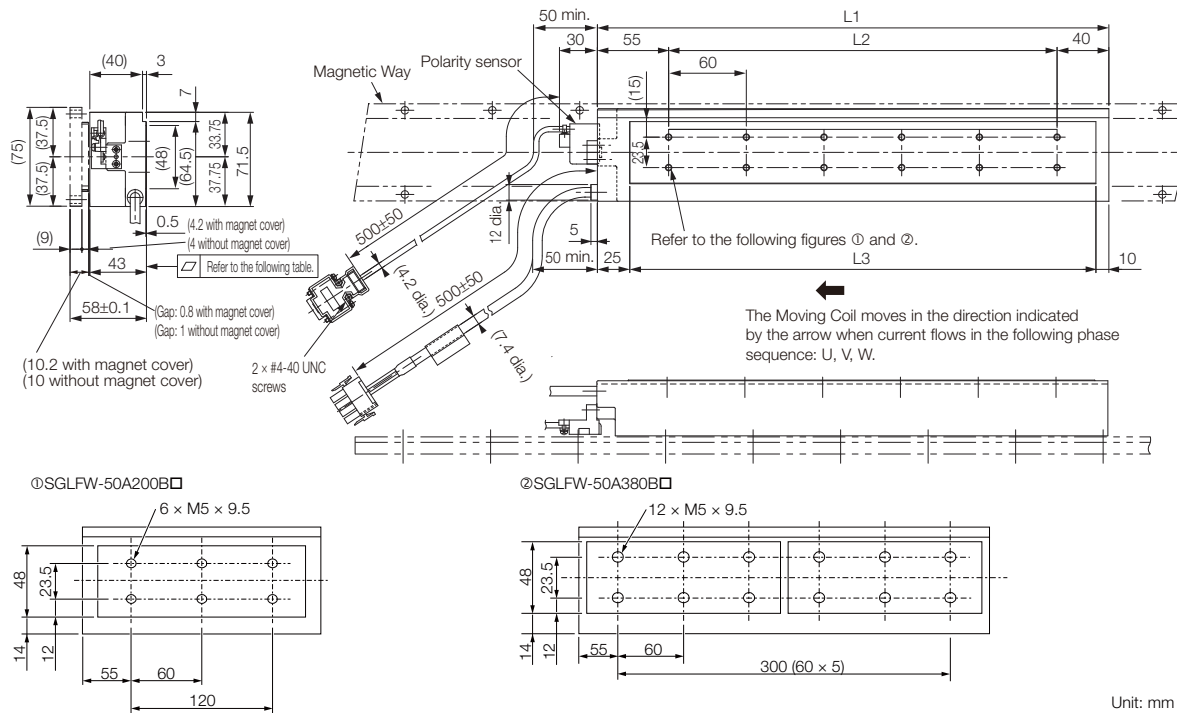

Moving Coil Model SGLFW-	L1	L2	L3	Approx. Mass [kg]
50A200B□	215	120	180	3.5
50A380B□	395	300	360	6.9

Note: The above dimensional drawing gives the dimensions for both models with polarity sensors and models without polarity sensors.  
 Refer to the following section for the connector specifications for the Sensor Cable and Servo Motor Main Circuit Cable.  
 SGLFW-50A□□□B□ Moving Coils (page 228)



◆ Moving Coils: SGLFW-50A□□□B□D

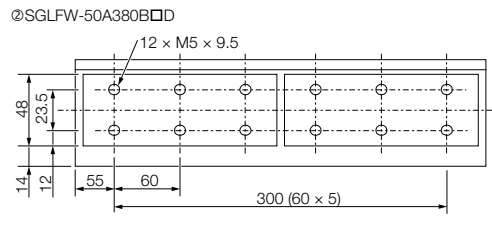
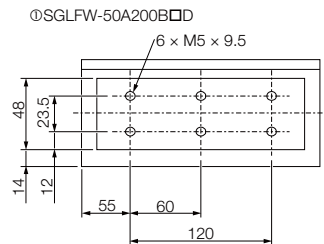
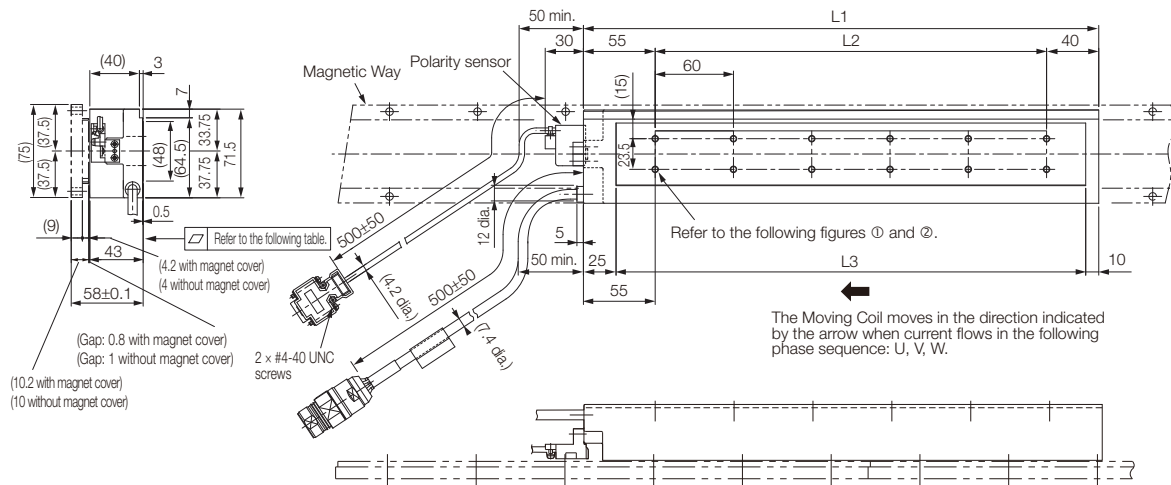

Unit: mm

Moving Coil Model SGLFW-	L1	L2	L3	Flatness	Approx. Mass [kg]
50A200B□D	215	120	180	0.2	3.5
50A380B□D	395	300	360	0.3	6.9

Note: The above dimensional drawing gives the dimensions for both models with polarity sensors and models without polarity sensors.  
Refer to the following section for the connector specifications for the Sensor Cable and Servo Motor Main Circuit Cable.  
🔗 SGLFW-35A□□□A□D and -50A□□□B□D Moving Coils (page 227)

## Linear Servo Motors

SGLF (Models with F-type Iron Cores)

### ◆ Magnetic Ways: SGLFM-50□□□A

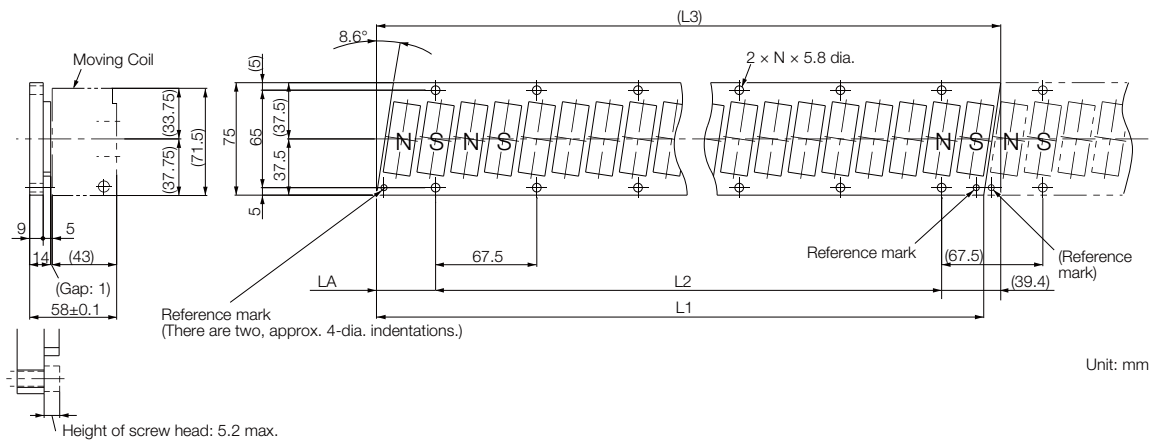

Mounting Section Details

Note: More than one Magnetic Way can be connected. Connect the Magnetic Ways so that the reference marks on them are aligned in the same direction as shown in the figure.

Magnetic Way Model SGLFM-	L1	L2	(L3)	LA	N	Approx. Mass [kg]
50405A	405 <sup>-0.1</sup> <sub>-0.3</sub>	337.5 (67.5 × 5)	(416.3)	39.4 <sup>0</sup> <sub>-0.2</sub>	6	2.8
50675A	675 <sup>-0.1</sup> <sub>-0.3</sub>	607.5 (67.5 × 9)	(686.3)	39.4 <sup>0</sup> <sub>-0.2</sub>	10	4.6
50945A	945 <sup>-0.1</sup> <sub>-0.3</sub>	877.5 (67.5 × 13)	(956.3)	39.4 <sup>0</sup> <sub>-0.2</sub>	14	6.5

# SGLFW-1Z

## ◆ Moving Coils: SGLFW-1ZA□□□B□

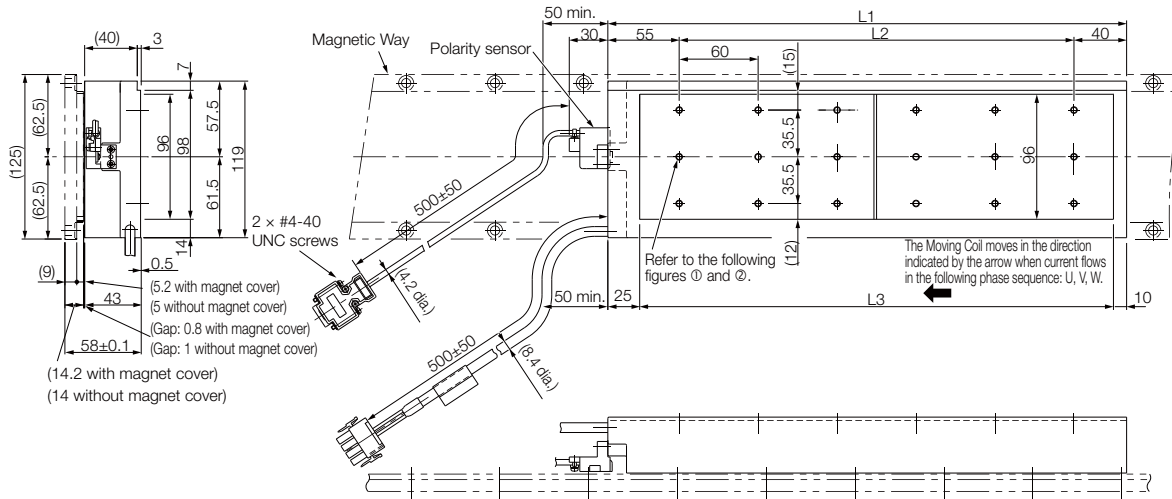

① SGLFW-1ZA200B□

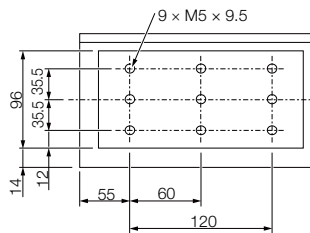

② SGLFW-1ZA380B□

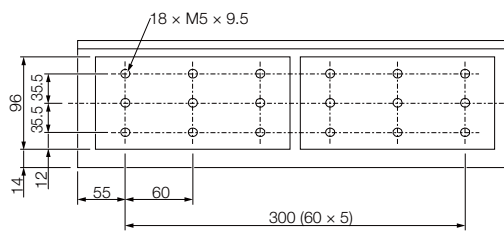

Unit: mm

Moving Coil Model SGLFW-	L1	L2	L3	Approx. Mass [kg]
1ZA200B□	215	120	180	6.4
1ZA380B□	395	300	360	11.5

Note: The above dimensional drawing gives the dimensions for both models with polarity sensors and models without polarity sensors.

Refer to the following section for the connector specifications for the Sensor Cable and Servo Motor Main Circuit Cable.

📖 SGLFW-1ZA□□□B□ Moving Coils (page 229)

**Linear Servo Motors**  
**SGLF (Models with F-type Iron Cores)**

◆ **Moving Coils: SGLFW-1ZA200B□D**

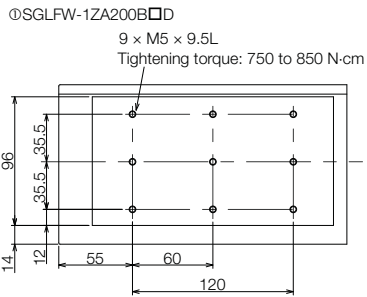
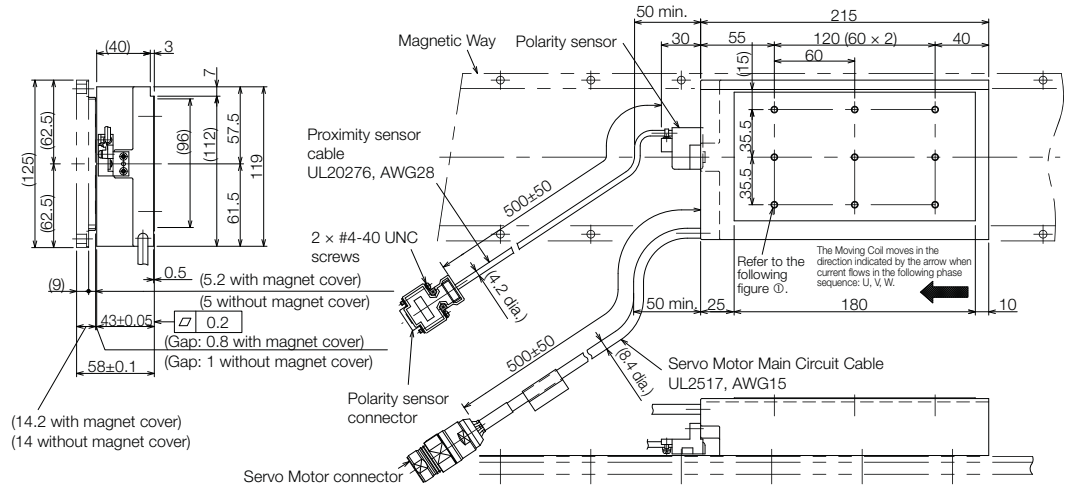

Approx. mass: 6.4 kg  
 Unit: mm

Note: The above dimensional drawing gives the dimensions for both models with polarity sensors and models without polarity sensors.  
 Refer to the following section for the connector specifications for the Sensor Cable and Servo Motor Main Circuit Cable.

📄 SGLFW-1ZA200B□D Moving Coils (page 230)

◆ Magnetic Ways: SGLFM-1Z□□□A

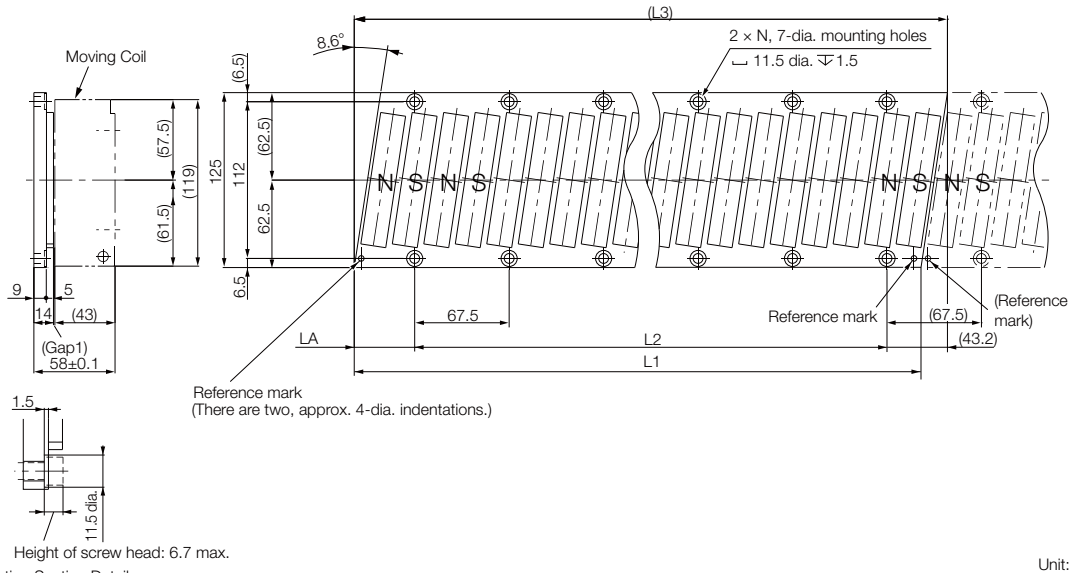

Note: More than one Magnetic Way can be connected. Connect the Magnetic Ways so that the reference marks on them are aligned in the same direction as shown in the figure.

Magnetic Way Model SGLFM-	L1	L2	(L3)	LA	N	Approx. Mass [kg]
1Z405A	405 <sup>-0.1</sup> <sub>-0.3</sub>	337.5 (67.5 × 5)	(423.9)	43.2 <sup>0</sup> <sub>-0.2</sub>	6	5
1Z675A	675 <sup>-0.1</sup> <sub>-0.3</sub>	607.5 (67.5 × 9)	(693.9)	43.2 <sup>0</sup> <sub>-0.2</sub>	10	8.3
1Z945A	945 <sup>-0.1</sup> <sub>-0.3</sub>	877.5 (67.5 × 13)	(963.9)	43.2 <sup>0</sup> <sub>-0.2</sub>	14	12

## Linear Servo Motors

SGLF (Models with F-type Iron Cores)

### ◆ SGLFW-20A□□□A□ and -35A□□□A□ Moving Coils

#### • Servo Motor Connector

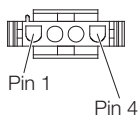

Plug: 350779-1  
Pins: 350218-3 or 350547-3 (No.1 to 3)  
350654-1 or 350669-1 (No. 4)  
Tyco Electronics Japan G.K.

#### Mating Connector

Cap: 350780-1  
Socket: 350536-3 or 350550-3

#### • Polarity Sensor Connector

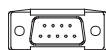

Pin connector: 17JE-23090-02 (D8C) -CG  
From DDK Ltd.

#### Mating Connector

Socket connector: 17JE-13090-02 (D8C) A-CG  
Studs: 17L-002C or 17L-002C1

#### • Polarity Sensor Output Signal

The figure on the right shows the relationship between the  $S_u$ ,  $S_v$ , and  $S_w$  polarity sensor output signals and the inverse power of each motor phase  $V_u$ ,  $V_v$ , and  $V_w$  when the Moving Coil moves in the direction indicated by the arrow in the dimensional drawings of the Moving Coil.

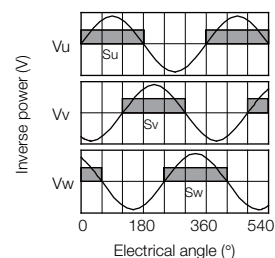

◆ SGLFW-35A□□□A□ D and -50A□□□B□ D Moving Coils

- Servo Motor Connector



Extension: ARRA06AMRPN182  
Pins: 021.279.1020  
From Interconnectron GmbH

Mating Connector  
Plug: APRA06BFRDN170  
Socket: 020.105.1020

- Polarity Sensor Connector

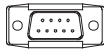

Pin connector: 17JE-23090-02 (D8C) -CG  
From DDK Ltd.

Mating Connector  
Socket connector: 17JE-13090-02 (D8C) A-CG  
Studs: 17L-002C or 17L-002C1

- Polarity Sensor Output Signal

The figure on the right shows the relationship between the Su, Sv, and Sw polarity sensor output signals and the inverse power of each motor phase Vu, Vv, and Vw when the Moving Coil moves in the direction indicated by the arrow in the dimensional drawings of the Moving Coil.

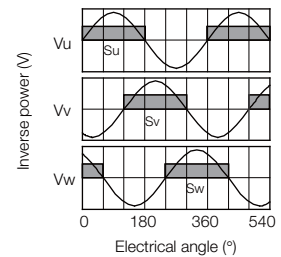

◆ SGLFW-50A□□□ B□ Moving Coils

- Servo Motor Connector

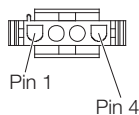

Plug: 350779-1  
 Pins: 350218-3 or 350547-3 (No.1 to 3)  
 350654-1 or 350669-1 (No. 4)  
 Tyco Electronics Japan G.K.

Mating Connector  
 Cap: 350780-1  
 Socket: 350537-3 or 350550-3

- Polarity Sensor Connector

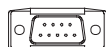

Pin connector: 17JE-23090-02 (D8C) -CG  
 From DDK Ltd.

Mating Connector  
 Socket connector: 17JE-13090-02 (D8C) A-CG  
 Studs: 17L-002C or 17L-002C1

- Polarity Sensor Output Signal

The figure on the right shows the relationship between the Su, Sv, and Sw polarity sensor output signals and the inverse power of each motor phase Vu, Vv, and Vw when the Moving Coil moves in the direction indicated by the arrow in the dimensional drawings of the Moving Coil.

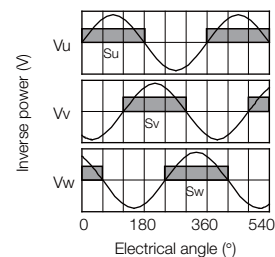



◆ SGLFW-1ZA□□□ B□ Moving Coils

- Servo Motor Connector

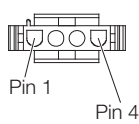

Plug: 350779-1  
Pins: 350218-3 or 350547-3 (No.1 to 3)  
350654-1 or 350669-1 (No. 4)  
Tyco Electronics Japan G.K.

Mating Connector  
Cap: 350780-1  
Socket: 350537-3 or 350550-3

- Polarity Sensor Connector

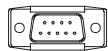

Pin connector: 17JE-23090-02 (D8C) -CG  
From DDK Ltd.

Mating Connector  
Socket connector: 17JE-13090-02 (D8C) A-CG  
Studs: 17L-002C or 17L-002C1

- Polarity Sensor Output Signal

The figure on the right shows the relationship between the Su, Sv, and Sw polarity sensor output signals and the inverse power of each motor phase Vu, Vv, and Vw when the Moving Coil moves in the direction indicated by the arrow in the dimensional drawings of the Moving Coil.

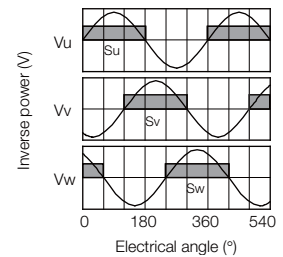

◆ SGLFW-1ZA200B□D Moving Coils

- Servo Motor Connector

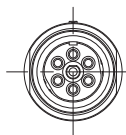

Extension: SROC06JMSCN169  
Pins: 021.423.1020  
From Interconnectron GmbH

Mating Connector  
Plug: SPUC06KFSDN236  
Socket: 020.030.1020

- Polarity Sensor Connector

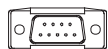

Pin connector: 17JE-23090-02 (D8C) -CG  
From DDK Ltd.

Mating Connector  
Socket connector: 17JE-13090-02 (D8C) A-CG  
Studs: 17L-002C or 17L-002C1

- Polarity Sensor Output Signal

The figure on the right shows the relationship between the Su, Sv, and Sw polarity sensor output signals and the inverse power of each motor phase Vu, Vv, and Vw when the Moving Coil moves in the direction indicated by the arrow in the dimensional drawings of the Moving Coil.

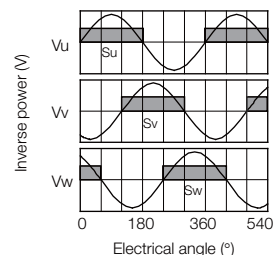

## Selecting Cables

### ◆ System Configurations

Example: SGLFW Servo Motors with F-type Iron Cores

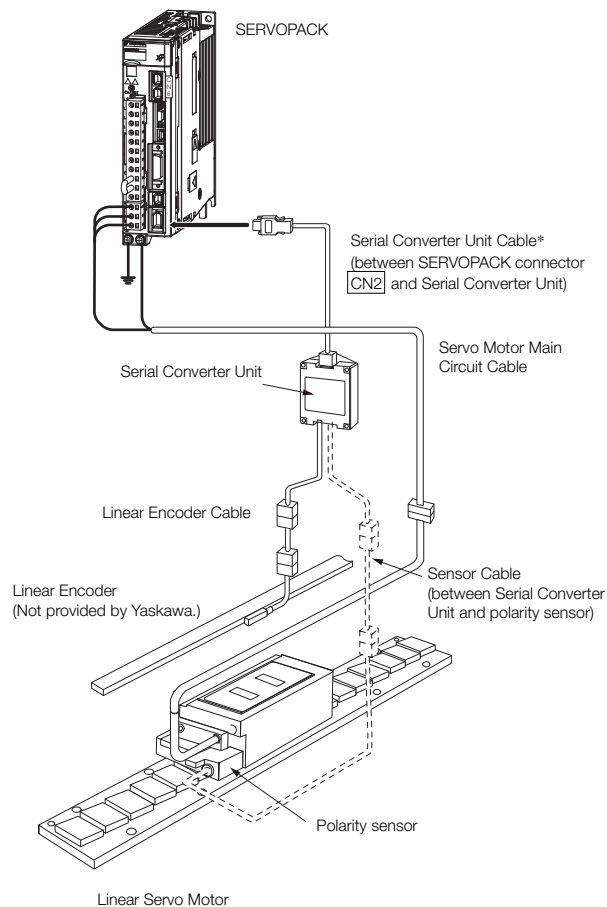

\* You can connect directly to an absolute linear encoder.

Note: 1. The above system configurations are for SGLFW Servo Motors with F-type Iron Cores. Refer to the manual for the Linear Servo Motor for configurations with other models.

2. Refer to the following manual for the following information.

- Cable dimensional drawings and cable connection specifications
- Order numbers and specifications of individual connectors for cables
- Order numbers and specifications for wiring materials

📖 *Σ-7-Series AC Servo Drive Peripheral Device Selection Manual* (Manual No.: SIEP S800001 32)

## Linear Servo Motors

SGLF (Models with F-type Iron Cores)

### Servo Motor Main Circuit Cables

Servo Motor Model	Length (L)	Order Number	Appearance
SGLFW-20A, -35A	1 m	JZSP-CLN11-01-E	
	3 m	JZSP-CLN11-03-E	
	5 m	JZSP-CLN11-05-E	
	10 m	JZSP-CLN11-10-E	
	15 m	JZSP-CLN11-15-E	
	20 m	JZSP-CLN11-20-E	
SGLFW-50A, -1ZA	1 m	JZSP-CLN21-01-E	
	3 m	JZSP-CLN21-03-E	
	5 m	JZSP-CLN21-05-E	
	10 m	JZSP-CLN21-10-E	
	15 m	JZSP-CLN21-15-E	
	20 m	JZSP-CLN21-20-E	
SGLFW-□□A □□□□□□	1 m	JZSP-CLN14-01-E	
	3 m	JZSP-CLN14-03-E	
	5 m	JZSP-CLN14-05-E	
	10 m	JZSP-CLN14-10-E	
	15 m	JZSP-CLN14-15-E	
	20 m	JZSP-CLN14-20-E	

Note: Shaded model numbers are non-stock items

\*1. Connector from Tyco Electronics Japan G.K.

\*2. Connector from Interconnectron GmbH

\*3. A connector is not provided on the Linear Servo Motor end. Obtain a connector according to your specifications. Refer to the next page for information on connectors.

### Linear Encoder Cables

Name	Servo Motor Model	Length* (L)	Order Number	Appearance
For linear encoder from Renishaw PLC	All Models	1 m	JZSP-CLL00-01-E	
		3 m	JZSP-CLL00-03-E	
		5 m	JZSP-CLL00-05-E	
		10 m	JZSP-CLL00-10-E	
		15 m	JZSP-CLL00-15-E	
For linear encoder from Heidenhain Corporation		1 m	JZSP-CLL30-01-E	
		3 m	JZSP-CLL30-03-E	
		5 m	JZSP-CLL30-05-E	
		10 m	JZSP-CLL30-10-E	
		15 m	JZSP-CLL30-15-E	

\* When using a JZDP-J00□-□□□-E Serial Converter Unit, do not exceed a cable length of 3 m.

## Serial Converter Unit Cables

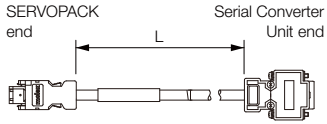
Servo Motor Model	Length (L)	Order Number	Appearance
All Models	1 m	JZSP-CLP70-01-E	
	3 m	JZSP-CLP70-03-E	
	5 m	JZSP-CLP70-05-E	
	10 m	JZSP-CLP70-10-E	
	15 m	JZSP-CLP70-15-E	
	20 m	JZSP-CLP70-20-E	

## Sensor Cables

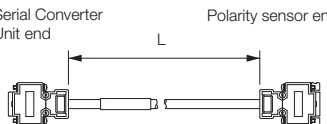
Servo Motor Model	Length (L)	Order Number	Appearance
SGLFW-□□A	1 m	JZSP-CLL10-01-E	
	3 m	JZSP-CLL10-03-E	
	5 m	JZSP-CLL10-05-E	
	10 m	JZSP-CLL10-10-E	
	15 m	JZSP-CLL10-15-E	

# SGLT (Models with T-type Iron Cores)

## Model Designations

### Moving Coil



**1st digit** Servo Motor Type

Code	Specification
T	With T-type iron core

**5th digit** Power Supply Voltage

Code	Specification
A	200 VAC

**10th digit** Sensor Specification and Cooling Method

Code	Specifications		Applicable Models
	Polarity Sensor	Cooling Method	
None	None	Self-cooled	All models
C*	None	Water-cooled	SGLTW-40, -80
H*	Yes	Water-cooled	
P	Yes	Self-cooled	All models

**2nd digit** Moving Coil/Magnetic Way

Code	Specification
W	Moving Coil

**6th+7th+8th digits** Length of Moving Coil

Code	Specification
170	170 mm
320	315 mm
400	394.2 mm
460	460 mm
600	574.2 mm

**3rd+4th digits** Magnet Height

Code	Specification
20	20 mm
35	36 mm
40	40 mm
50	51 mm
80	76.5 mm

**9th digit** Design Revision Order

A, B ...  
H: High-efficiency model

**11th digit** Connector for Servo Motor Main Circuit Cable

Code	Specification	Applicable Models
None	Connector from Tyco Electronics Japan G.K.	SGLTW-20A□□□□□□, -35A□□□□□□
	MS connector	SGLTW-40A□□□□B□, -80A□□□□B□
	Loose lead wires with no connector	SGLTW-35A□□□□H□, -50A□□□□H□

■ Non Stock Items

\* Contact your Yaskawa representative for the characteristics, dimensions, and other details on Servo Motors with these specifications.

Note: This information is provided to explain model numbers. It is not meant to imply that models are available for all combinations of codes.

### Magnetic Way



**1st digit** Servo Motor Type  
(Same as for the Moving Coil.)

**2nd digit** Moving Coil/Magnetic Way

Code	Specification
M	Magnetic Way

**3rd+4th digits** Magnet Height  
(Same as for the Moving Coil.)

**5th+6th+7th digits** Length of Magnetic Way

Code	Specification
324	324 mm
405	405 mm
540	540 mm
675	675 mm
756	756 mm
945	945 mm

**9th digit** Options

Code	Specification	Applicable Models
None	Without options	-
C	With magnet cover	All models
Y	With base and magnet cover	SGLTM-20, -35*, -40, -80

■ Non Stock Items

**8th digit** Design Revision Order

A, B ...  
H: High-efficiency model

\* The SGLTM-35□□□ H (high-efficiency models) do not support this specification.

Note: This information is provided to explain model numbers. It is not meant to imply that models are available for all combinations of codes.

## Precautions on Moving Coils with Polarity Sensors



**Note** When you use a Moving Coil with a Polarity Sensor, the Magnetic Way must cover the bottom of the polarity sensor. Refer to the example that shows the correct installation. When determining the length of the Moving Coil's stroke or the length of the Magnetic Way, consider the total length of the Moving Coil and the polarity sensor. Refer to the following table.

### Correct Installation

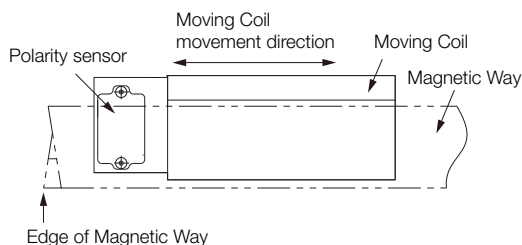

### Incorrect Installation

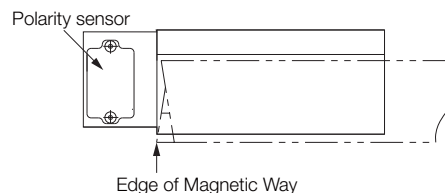

### ◆ Total Length of Moving Coil with Polarity Sensor

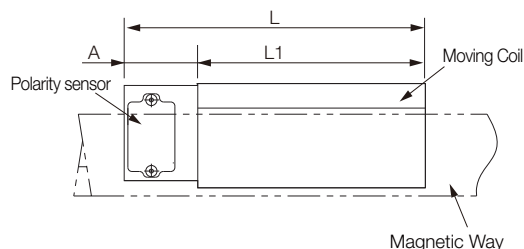

Moving Coil Model SGLTW-	Length of Moving Coil, L1 [mm]	Length of Polarity Sensor, A [mm]	Total Length, L [mm]
20A170AP□	170	34	204
20A320AP□	315		349
20A460AP□	460		494
35A170AP□	170	34	204
35A320AP□	315		349
35A460AP□	460		494
35A170HP□	170	34	204
35A320HP□	315		349
50A170HP□	170	34	204
50A320HP□	315		349
40A400BH□ 40A400BP□	394.2	26	420.2
40A600BH□ 40A600BP□	574.2	26	600.2
80A400BH□ 80A400BP□	394.2	26	420.2
80A600BH□ 80A600BP□	574.2	26	600.2

## Specifications and Ratings

### Specifications

Linear Servo Motor Moving Coil Model SGLTW-		Standard Models										High-efficiency Models			
		20A			35A			40A		80A		35A		50A	
		170A	320A	460A	170A	320A	460A	400B	600B	400B	600B	170H	320H	170H	320H
Time Rating		Continuous													
Thermal Class		B													
Insulation Resistance		500 VDC, 10 MΩmin.													
Withstand Voltage		1,500 VAC for 1 minute													
Excitation		Permanent magnet													
Cooling Method		Self-cooled													
Protective Structure		IP00													
Environmental Condi- tions	Surrounding Air Tempera- ture	0°C to 40°C (with no freezing)													
	Surrounding Air Humidity	20% to 80% relative humidity (with no condensation)													
	Installation Site	<ul style="list-style-type: none"> <li>• Must be indoors and free of corrosive and explosive gases.</li> <li>• Must be well-ventilated and free of dust and moisture.</li> <li>• Must facilitate inspection and cleaning.</li> <li>• Must have an altitude of 1,000 m or less.</li> <li>• Must be free of strong magnetic fields.</li> </ul>													
Shock Resis- tance	Impact Accel- eration Rate	196 m/s <sup>2</sup>													
	Number of Impacts	2 times													
Vibra- tion Resis- tance	Vibration Acceleration Rate	49 m/s <sup>2</sup> (the vibration resistance in three directions, vertical, side-to-side, and front-to-back)													



# Ratings

Linear Servo Motor Moving Coil Model SGLTW-		Standard Models										High-efficiency Models			
		20A			35A			40A		80A		35A		50A	
		170A	320A	460A	170A	320A	460A	400B	600B	400B	600B	170H	320H	170H	320H
Rated Motor Speed (Reference Speed during Speed Control) <sup>*1</sup>		3.0	3.0	3.0	2.5	2.5	2.5	1.5	2.0	2.0	2.0	2.5	2.0	2.0	2.0
Maximum Speed <sup>*1</sup>	m/s	5.0	5.0	5.0	5.0	5.0	5.0	3.1	3.1	2.5	2.5	4.8	4.8	3.2	3.1
Rated Force <sup>*1, *2</sup>	N	130	250	380	220	440	670	670	1000	1300	2000	300	600	450	900
Maximum Force <sup>*1</sup>	N	380	760	1140	660	1320	2000	2600	4000	5000	7500	600	1200	900	1800
Rated Current <sup>*1</sup>	Arms	2.3	4.4	6.7	3.5	7.0	10.7	7.3	10.9	11.1	17.1	5.1	10.1	5.1	10.2
Maximum Current <sup>*1</sup>	Arms	7.7	15.4	23.2	12.1	24.2	36.7	39.4	60.6	57.9	86.9	11.9	23.9	11.8	23.6
Moving Coil Mass	kg	2.5	4.6	6.7	3.7	6.8	10	15	23	24	35	4.9	8.8	6.0	11
Force Constant	N/Arms	61.0	61.0	61.0	67.5	67.5	67.5	99.1	99.1	126	126	64.0	64.0	95.2	95.2
BEMF Constant	V <sub>rms</sub> /(m/s)/phase	20.3	20.3	20.3	22.5	22.5	22.5	33.0	33.0	42.0	42.0	21.3	21.3	31.7	31.7
Motor Constant	N/√W	18.7	26.5	32.3	26.7	37.5	46.4	61.4	75.2	94.7	116	37.4	52.9	48.6	68.7
Electrical Time Constant	ms	5.9	5.9	5.9	6.9	6.8	6.9	15	15	17	17	15	16	16	17
Mechanical Time Constant	ms	7.1	6.6	6.4	5.2	4.8	4.6	4.0	4.1	2.7	2.6	3.5	3.1	2.5	2.4
Thermal Resistance (with Heat Sink)	K/W	1.01	0.49	0.38	0.76	0.44	0.32	0.24	0.20	0.22	0.18	0.76	0.40	0.61	0.30
Thermal Resistance (without Heat Sink)	K/W	1.82	1.11	0.74	1.26	0.95	0.61	0.57	0.40	0.47	0.33	1.26	0.83	0.97	0.80
Magnetic Attraction <sup>*3</sup>	N	0	0	0	0	0	0	0	0	0	0	0	0	0	0
Magnetic Attraction on One Side <sup>*4</sup>	N	800	1590	2380	1400	2780	4170	3950	5890	7650	11400	1400	2780	2000	3980
Combined Magnetic Way, SGLTM-		20□□□□□			35□□□□□			40□□□□□		80□□□□□		35□□□□□		50□□□□□	
Combined Serial Converter Unit, JZDP-□□□□-		011	012	013	014	015	016	185	186	187	188	105	106	108	109
Applicable SERVOPACKs	SGD7S-	3R8 A	7R6 A	120 A	5R5 A	120 A	180 A	180 A	330 A	330 A	550 A	5R5 A	120 A	5R5 A	120 A
	SGD7W-	5R5 A	7R6 A	-	5R5 A	-	-	-	-	-	-	5R5 A	-	5R5 A	-

\*1. These values are for operation in combination with a SERVOPACK when the temperature of the armature winding is 100°C. The values for other items are at 20°C. These are typical values.

\*2. The rated forces are the continuous allowable force values at a surrounding air temperature of 40°C with an aluminum heat sink of the dimensions given in the following table.

- Heat Sink Dimensions
  - 254 mm × 254 mm × 25 mm: SGLTW-20A170A and -35A170A
  - 400 mm × 500 mm × 40 mm: SGLTW-20A320A, -20A460A, -35A170H, -35A320A, -35A320H, -35A460A, and -50A170H
  - 609 mm × 762 mm × 50 mm: SGLTW-40A400B, -40A600B, -50A320H, -80A400B, and -80A600B

\*3. The unbalanced magnetic gap that results from the Moving Coil installation condition causes a magnetic attraction on the Moving Coil.

\*4. The value that is given is the magnetic attraction that is generated on one side of the Magnetic Way.

Linear Servo Motors

## Force-Motor Speed Characteristics

**A** : Continuous duty zone ——— (solid lines): With three-phase 200-V input  
**B** : Intermittent duty zone - - - - - (dotted lines): With single-phase 200-V input

### Standard Models

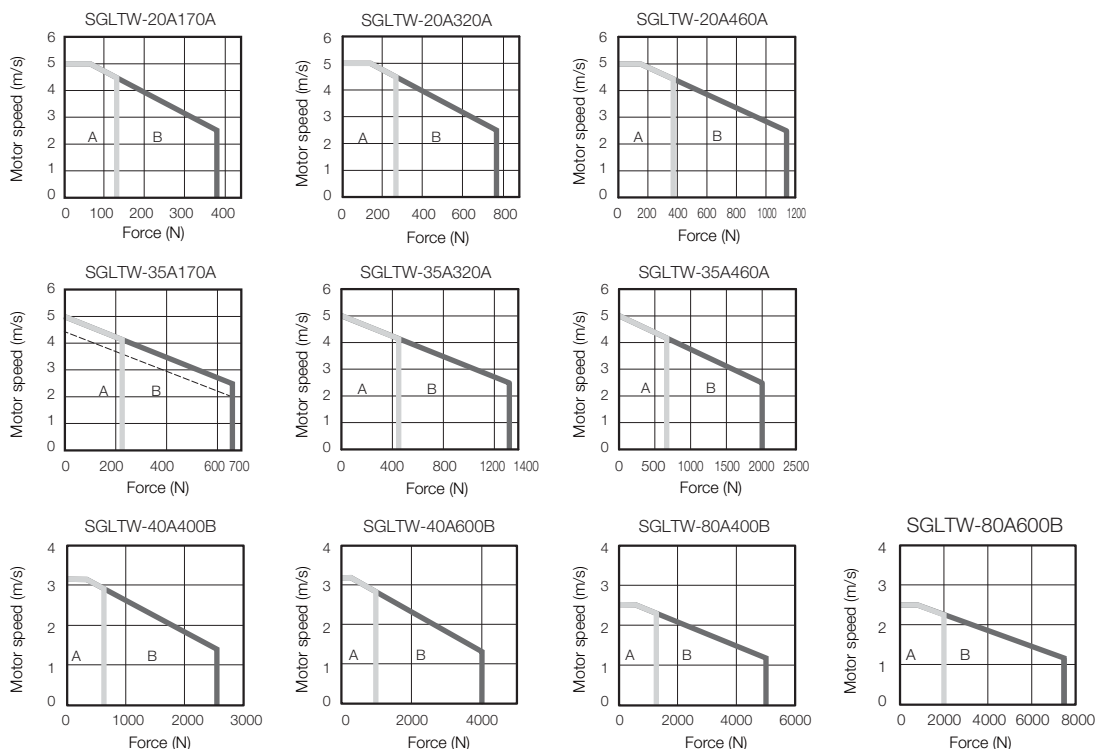

### High-efficiency Models

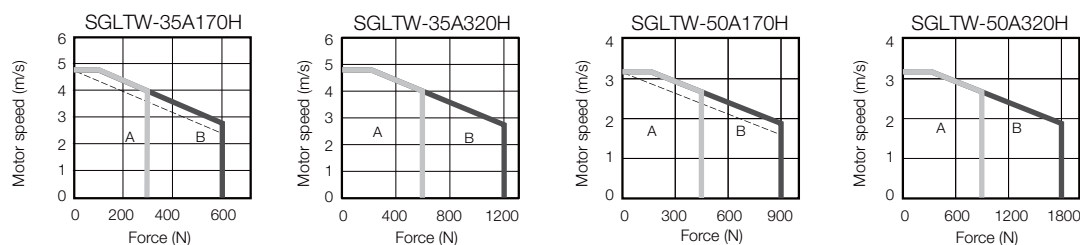

- Note: 1. These values are for operation in combination with a SERVOPACK when the temperature of the armature winding is 100°C. These are typical values.  
 2. The characteristics in the intermittent duty zone depend on the power supply voltage.  
 3. If the effective force is within the allowable range for the rated force, the Servo Motor can be used within the intermittent duty zone.  
 4. If you use a Servo Motor Main Circuit Cable that exceeds 20 m, the intermittent duty zone in the torque-motor speed characteristics will become smaller because the voltage drop increases.

## Servo Motor Overload Protection Characteristics

The overload detection level is set for hot start conditions with a Servo Motor surrounding air temperature of 40°C.

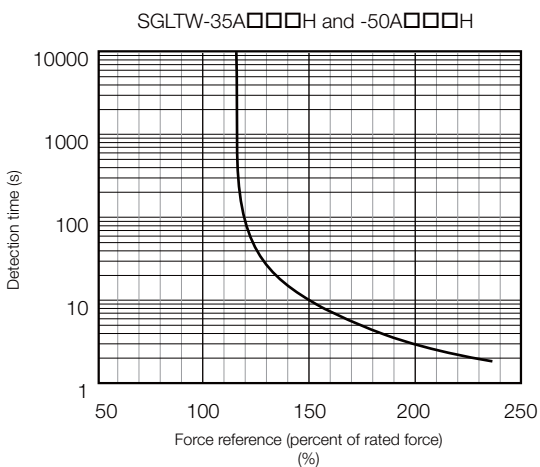
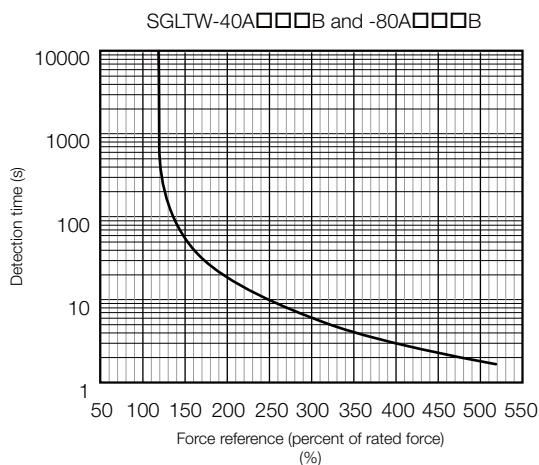
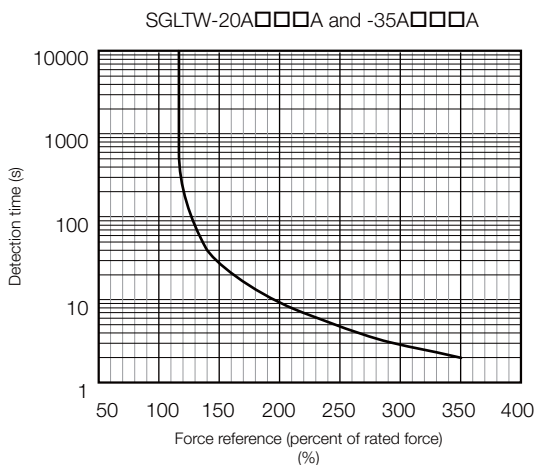

Note: The above overload protection characteristics do mean that you can perform continuous duty operation with an output of 100% or higher. Use the Servo Motor so that the effective force remains within the continuous duty zone given in *Force-Motor Speed Characteristics* on page 238.

## External Dimensions

### SGLTW-20: Standard Models

#### ◆ Moving Coils: SGLTW-20A□□□A□

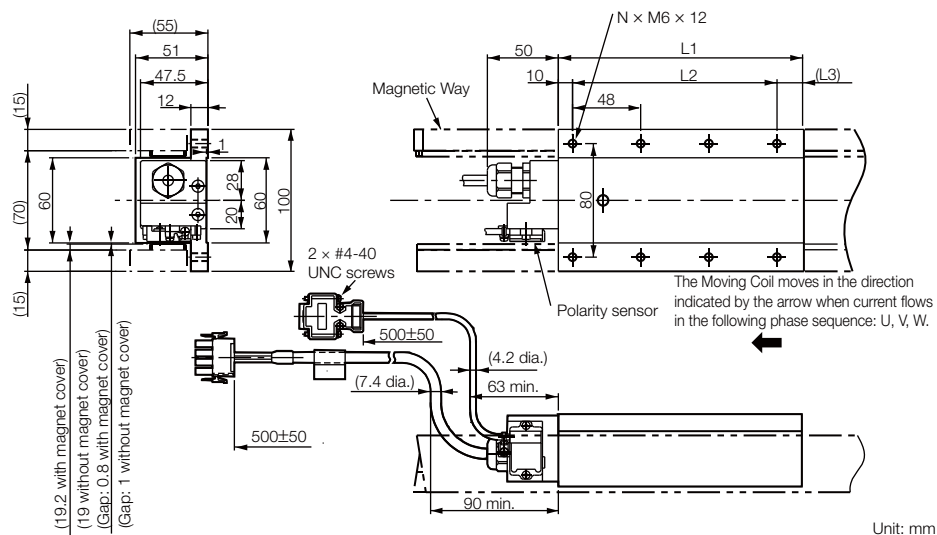

Moving Coil Model SGLTW-	L1	L2	(L3)	N	Approx. Mass [kg]
20A170A□	170	144 (48 × 3)	(16)	8	2.5
20A320A□	315	288 (48 × 6)	(17)	14	4.6
20A460A□	460	432 (48 × 9)	(18)	20	6.7

Refer to the following section for the connector specifications for the Sensor Cable and Servo Motor Main Circuit Cable.

🔌 SGLTW-20A□□□A□ and -35A□□□A□ Moving Coils (page 256)

◆ Magnetic Ways: SGLTM-20□□□ A

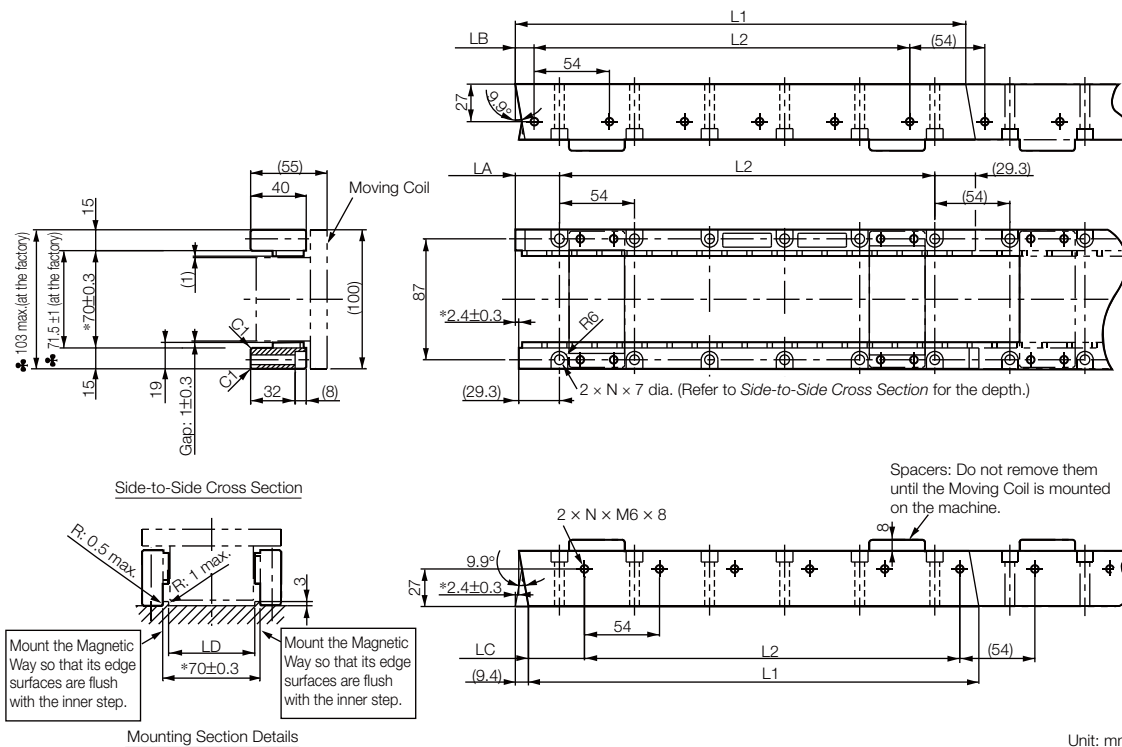

Note: 1. Two Magnetic Way tracks are used together as a set. For safety, when they are shipped, the two tracks are secured to a mounting spacer made from aluminum.

2. More than one Magnetic Way can be connected.

3. Dimensions with asterisks are the distances between the Magnetic Way tracks. Install the tracks according to the specified dimensions. Observe the dimensions given in Mounting Section Details after installation. Dimensions when the Magnetic Way is shipped from the factory are indicated by ♣.

4. Use socket head screws of strength class 10.9 or higher for the Magnetic Way mounting screws. (Do not use stainless steel screws.)

Magnetic Way Model SGLTM-	L1	L2	LA	LB	LC	LD	N	Approx. Mass [kg]
20324A□	324 <sup>-0.1</sup> <sub>-0.3</sub>	270 (54 × 5)	31.7 <sup>0</sup> <sub>-0.2</sub>	13.7 <sup>0</sup> <sub>-0.2</sub>	40.3 <sup>0</sup> <sub>-0.2</sub>	62 <sup>+0.6</sup> <sub>0</sub>	6	3.4
20540A□	540 <sup>-0.1</sup> <sub>-0.3</sub>	486 (54 × 9)	31.7 <sup>0</sup> <sub>-0.2</sub>	13.7 <sup>0</sup> <sub>-0.2</sub>	40.3 <sup>0</sup> <sub>-0.2</sub>	62 <sup>+0.6</sup> <sub>0</sub>	10	5.7
20756A□	756 <sup>-0.1</sup> <sub>-0.3</sub>	702 (54 × 13)	31.7 <sup>0</sup> <sub>-0.2</sub>	13.7 <sup>0</sup> <sub>-0.2</sub>	40.3 <sup>0</sup> <sub>-0.2</sub>	62 <sup>+0.6</sup> <sub>0</sub>	14	7.9

◆ Magnetic Ways with Bases: SGLTM-20□□□AY

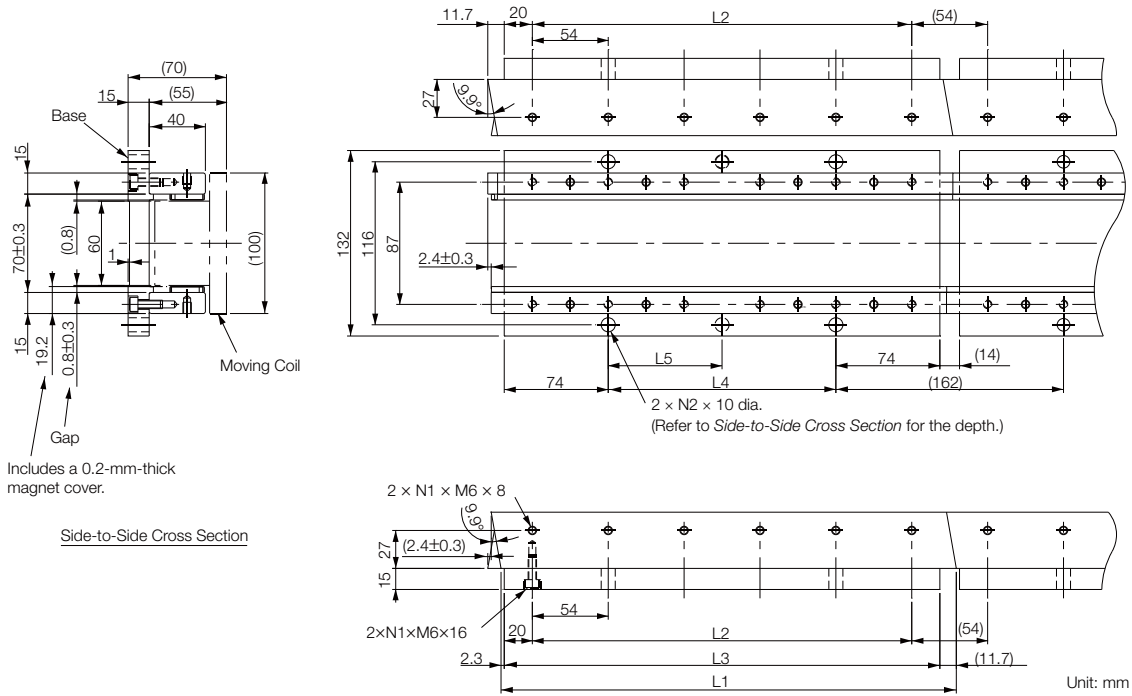

Note: Two Magnetic Way tracks are used together as a set. More than one Magnetic Way can be connected.

Magnetic Way Model SGLTM-	L1	L2	L3	L4	L5	N1	N2	Approx. Mass [kg]
20324AY	324 <sup>-0.1</sup> <sub>-0.3</sub>	270	310	162	162	6	2	5.1
20540AY	540 <sup>-0.1</sup> <sub>-0.3</sub>	486	526	378	189	10	3	8.5
20756AY	756 <sup>-0.1</sup> <sub>-0.3</sub>	702	742	594	198	14	4	12

## SGLTW-35: Standard Models

### ◆ Moving Coils: SGLTW-35A□□□A□

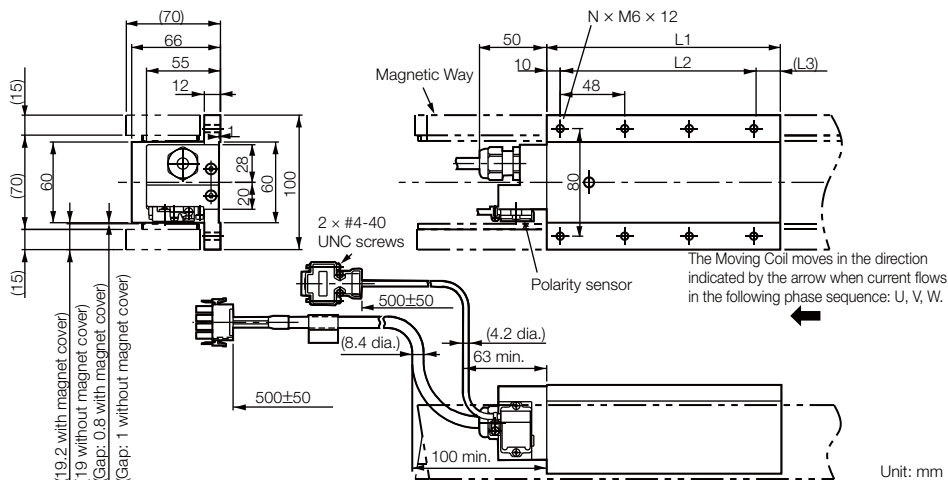

Moving Coil Model SGLTW-	L1	L2	(L3)	N	Approx. Mass [kg]
35A170A□	170	144 (48 × 3)	(16)	8	3.7
35A320A□	315	288 (48 × 6)	(17)	14	6.8
35A460A□	460	432 (48 × 9)	(18)	20	10

Refer to the following section for the connector specifications for the Sensor Cable and Servo Motor Main Circuit Cable.

☞ SGLTW-20A□□□A□ and -35A□□□A□ Moving Coils (page 256)

◆ Magnetic Ways: SGLTM-35□□□ A□

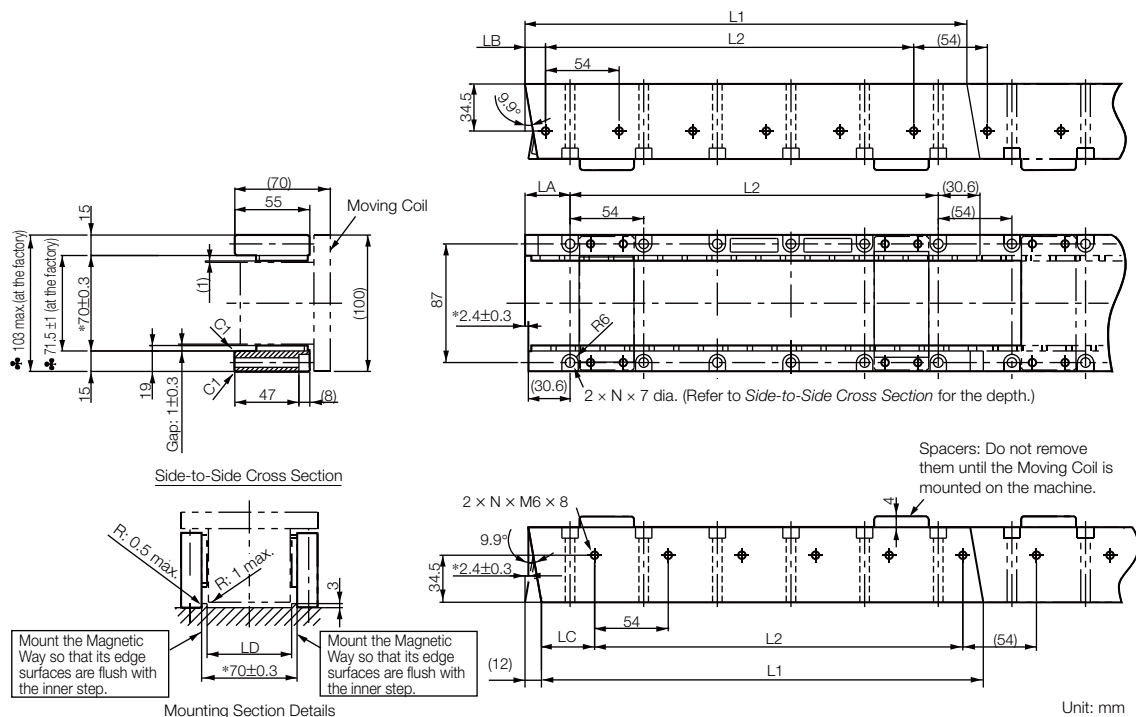

- Note: 1. Two Magnetic Way tracks are used together as a set. For safety, when they are shipped, the two tracks are secured to a mounting spacer made from aluminum.
2. More than one Magnetic Way can be connected.
3. Dimensions with asterisks are the distances between the Magnetic Way tracks. Install the tracks according to the specified dimensions. Observe the dimensions given in Mounting Section Details after installation. Dimensions when the Magnetic Way is shipped from the factory are indicated by ♣.
4. Use socket head screws of strength class 10.9 or higher for the Magnetic Way mounting screws. (Do not use stainless steel screws.)

Magnetic Way Model SGLTM-	L1	L2	LA	LB	LC	LD	N	Approx. Mass [kg]
35324A□	324 <sup>-0.1</sup> <sub>-0.3</sub>	270 (54 × 5)	33 <sup>0</sup> <sub>-0.2</sub>	15 <sup>0</sup> <sub>-0.2</sub>	39 <sup>0</sup> <sub>-0.2</sub>	62 <sup>+0.6</sup> <sub>0</sub>	6	4.8
35540A□	540 <sup>-0.1</sup> <sub>-0.3</sub>	486 (54 × 9)	33 <sup>0</sup> <sub>-0.2</sub>	15 <sup>0</sup> <sub>-0.2</sub>	39 <sup>0</sup> <sub>-0.2</sub>	62 <sup>+0.6</sup> <sub>0</sub>	10	8
35756A□	756 <sup>-0.1</sup> <sub>-0.3</sub>	702 (54 × 13)	33 <sup>0</sup> <sub>-0.2</sub>	15 <sup>0</sup> <sub>-0.2</sub>	39 <sup>0</sup> <sub>-0.2</sub>	62 <sup>+0.6</sup> <sub>0</sub>	14	11



◆ Magnetic Ways with Bases: SGLTM-35□□□AY

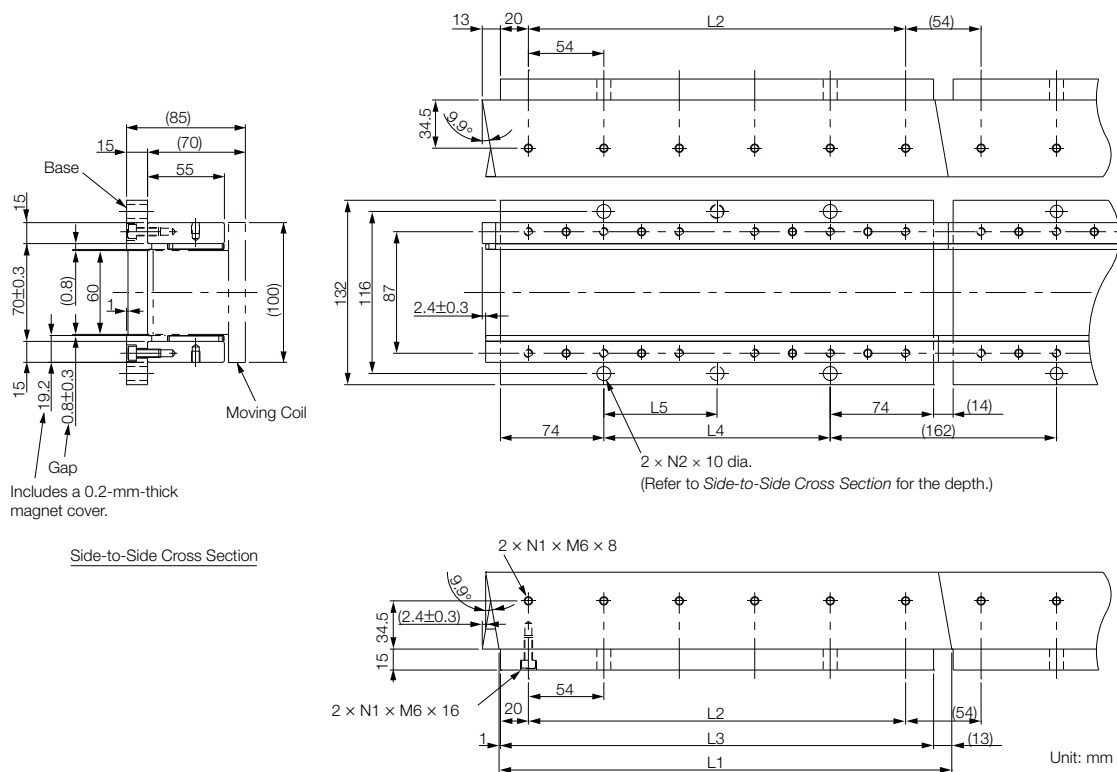

Note: Two Magnetic Way tracks are used together as a set. More than one Magnetic Way can be connected.

Magnetic Way Model SGLTM-	L1	L2	L3	L4	L5	N1	N2	Approx. Mass [kg]
35324AY	324 <sup>-0.1</sup> <sub>-0.3</sub>	270	310	162	162	6	2	6.4
35540AY	540 <sup>-0.1</sup> <sub>-0.3</sub>	486	526	378	189	10	3	11
35756AY	756 <sup>-0.1</sup> <sub>-0.3</sub>	702	742	594	198	14	4	15

## SGLTW-35□ □ □ □ H□ : High-Efficiency Models

### ◆ Moving Coils: SGLTW-35A□□□□ H□

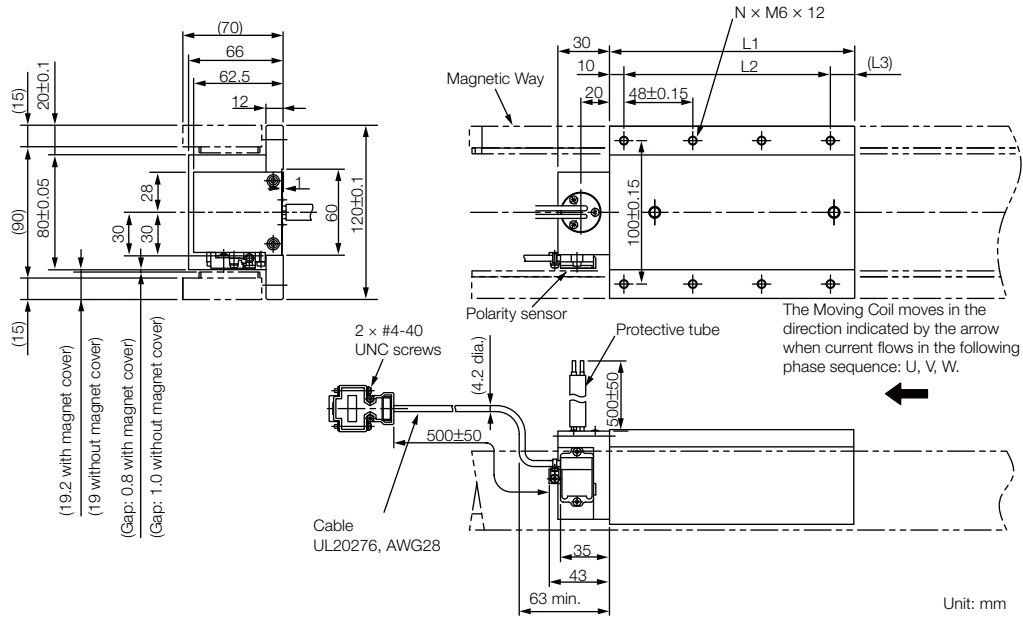

Moving Coil Model SGLTW-	L1	L2	L3	N	Approx. Mass [kg]
35A170H□	170	144 (48 × 3)	(16)	8	4.7
35A320H□	315	288 (48 × 6)	(17)	14	8.8

Refer to the following section for the connector specifications for the Sensor Cable and Servo Motor Main Circuit Cable.

🔌 SGLTW-35A□□□□ H□ and -50A□□□□ H□ Moving Coils (page 258)

◆ Magnetic Ways: SGLTM-35□□□ H□

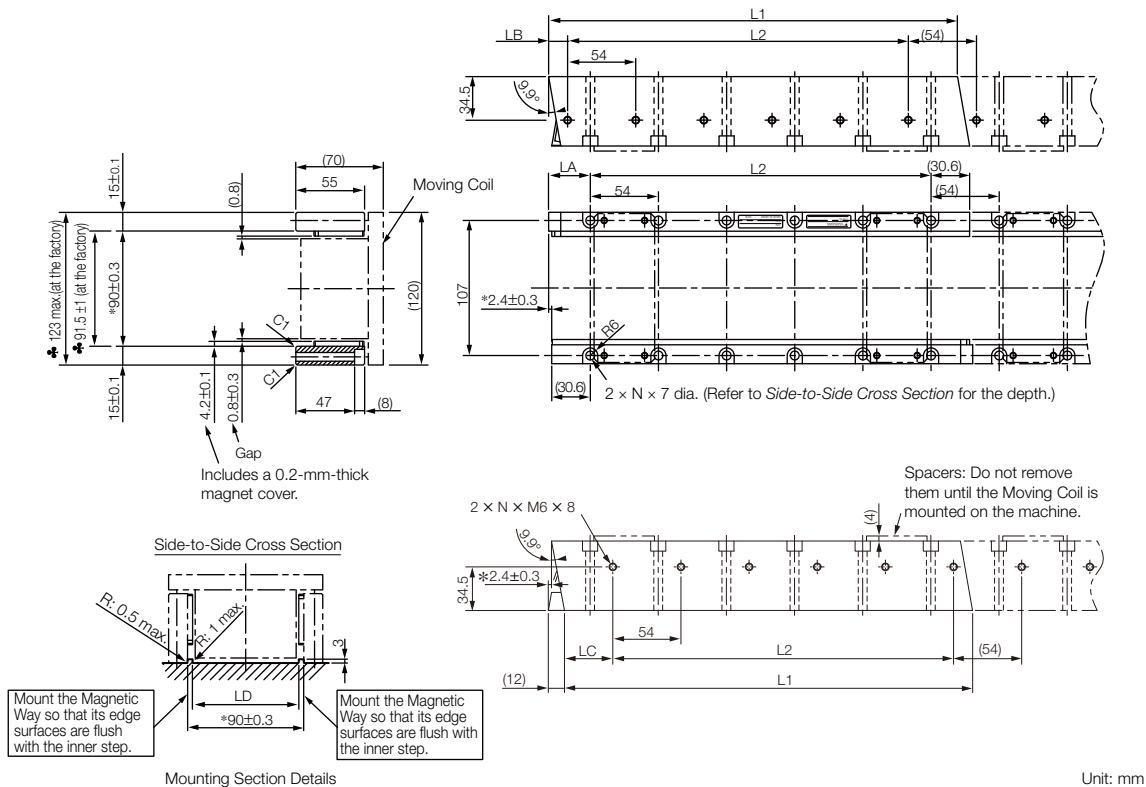

- Note: 1. Two Magnetic Way tracks are used together as a set. For safety, when they are shipped, the two tracks are secured to a mounting spacer made from aluminum.
2. More than one Magnetic Way can be connected.
3. Dimensions with asterisks are the distances between the Magnetic Way tracks. Install the tracks according to the specified dimensions. Observe the dimensions given in Mounting Section Details after installation. Dimensions when the Magnetic Way is shipped from the factory are indicated by ♣.
4. Use socket head screws of strength class 10.9 or higher for the Magnetic Way mounting screws. (Do not use stainless steel screws.)

Magnetic Way Model SGLTM-	L1	L2	LA	LB	LC	LD	N	Approx. Mass [kg]
35324H□	324 <sup>-0.1</sup> <sub>-0.3</sub>	270 (54 × 5)	33 <sup>0</sup> <sub>-0.2</sub>	15 <sup>0</sup> <sub>-0.2</sub>	39 <sup>0</sup> <sub>-0.2</sub>	82 <sup>+0.6</sup> <sub>0</sub>	6	4.8
35540H□	540 <sup>-0.1</sup> <sub>-0.3</sub>	486 (54 × 9)	33 <sup>0</sup> <sub>-0.2</sub>	15 <sup>0</sup> <sub>-0.2</sub>	39 <sup>0</sup> <sub>-0.2</sub>	82 <sup>+0.6</sup> <sub>0</sub>	10	8
35756H□	756 <sup>-0.1</sup> <sub>-0.3</sub>	702 (54 × 13)	33 <sup>0</sup> <sub>-0.2</sub>	15 <sup>0</sup> <sub>-0.2</sub>	39 <sup>0</sup> <sub>-0.2</sub>	82 <sup>+0.6</sup> <sub>0</sub>	14	11

## SGLTW-40: Standard Models

### ◆ Moving Coils: SGLTW-40A□□□B□

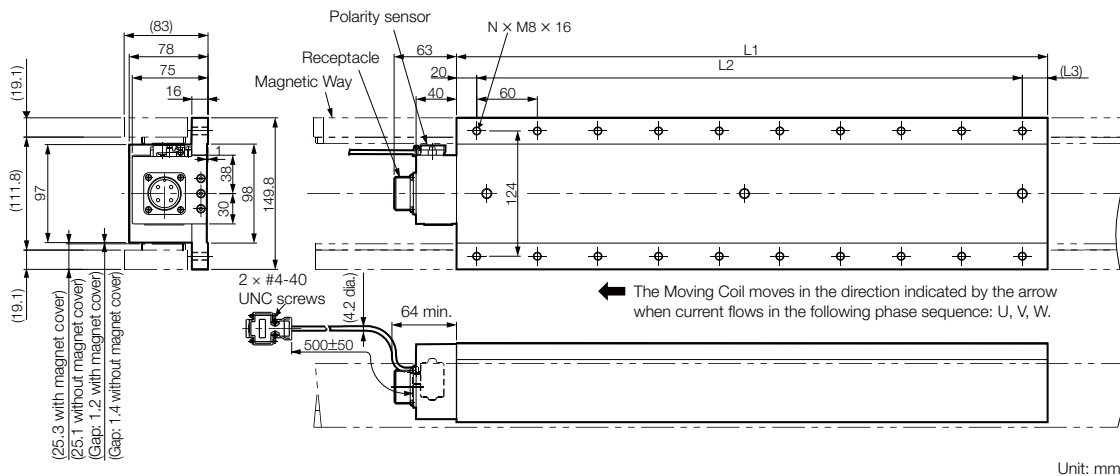

Moving Coil Model SGLTW-	L1	L2	(L3)	N	Approx. Mass [kg]
40A400B□	394.2	360 (60 × 6)	(15)	14	15
40A600B□	574.2	540 (60 × 9)	(15)	20	22

Refer to the following section for the connector specifications for the Sensor Cable and Servo Motor Main Circuit Cable.

🔗 SGLTW-40A□□□B□ and -80A□□□B□ Moving Coils (page 257)



◆ Magnetic Ways with Bases: SGLTM-40□□□AY

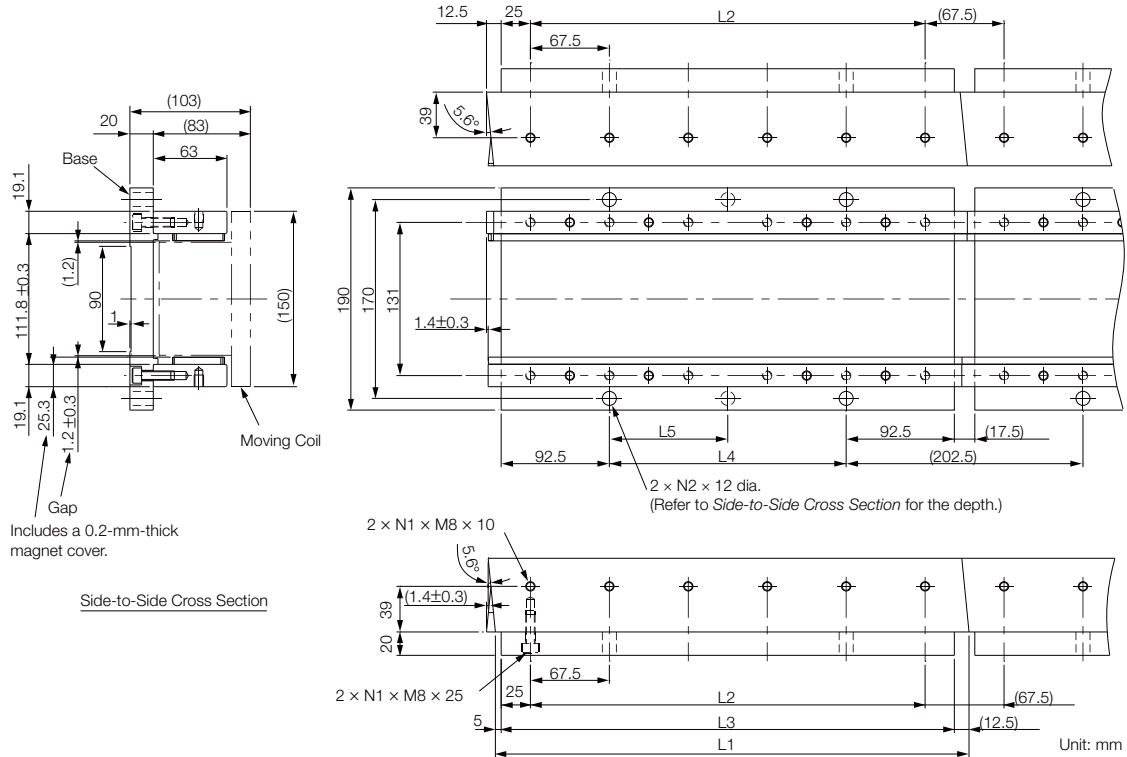

Note: Two Magnetic Way tracks are used together as a set. More than one Magnetic Way can be connected.

Magnetic Way Model SGLTM-	L1	L2	L3	L4	L5	N1	N2	Approx. Mass [kg]
40405AY	405 <sup>-0.1</sup> <sub>-0.3</sub>	337.5	387.5	202.5	202.5	6	2	13
40675AY	675 <sup>-0.1</sup> <sub>-0.3</sub>	607.5	657.5	472.5	236.25	10	3	21
40945AY	945 <sup>-0.1</sup> <sub>-0.3</sub>	877.5	927.5	742.5	247.5	14	4	30

## SGLTW-50: High-Efficiency Models

### ◆ Moving Coils: SGLTW-50A□□□□H□

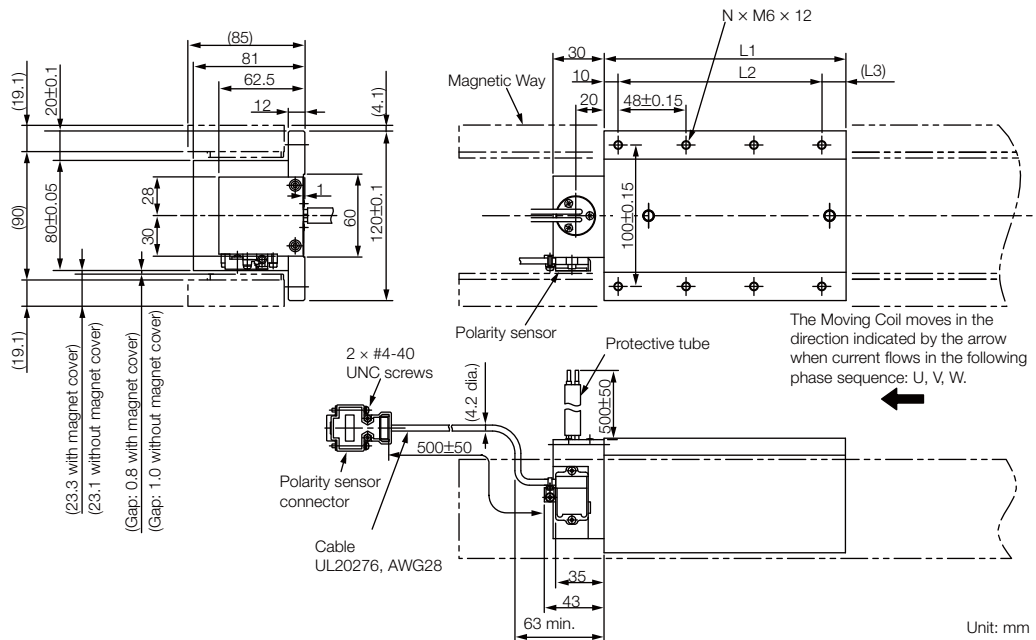

Moving Coil Model SGLTW-	L1	L2	(L3)	N	Approx. Mass [kg]
50A170H□	170	144 (48 × 3)	(16)	8	6
50A320H□	315	288 (48 × 6)	(17)	14	11

Refer to the following section for the connector specifications for the Sensor Cable and Servo Motor Main Circuit Cable.

☞ SGLTW-35A□□□□H□ and -50A□□□□H□ Moving Coils (page 258)

◆ Magnetic Ways: SGLTM-50□□□ H□

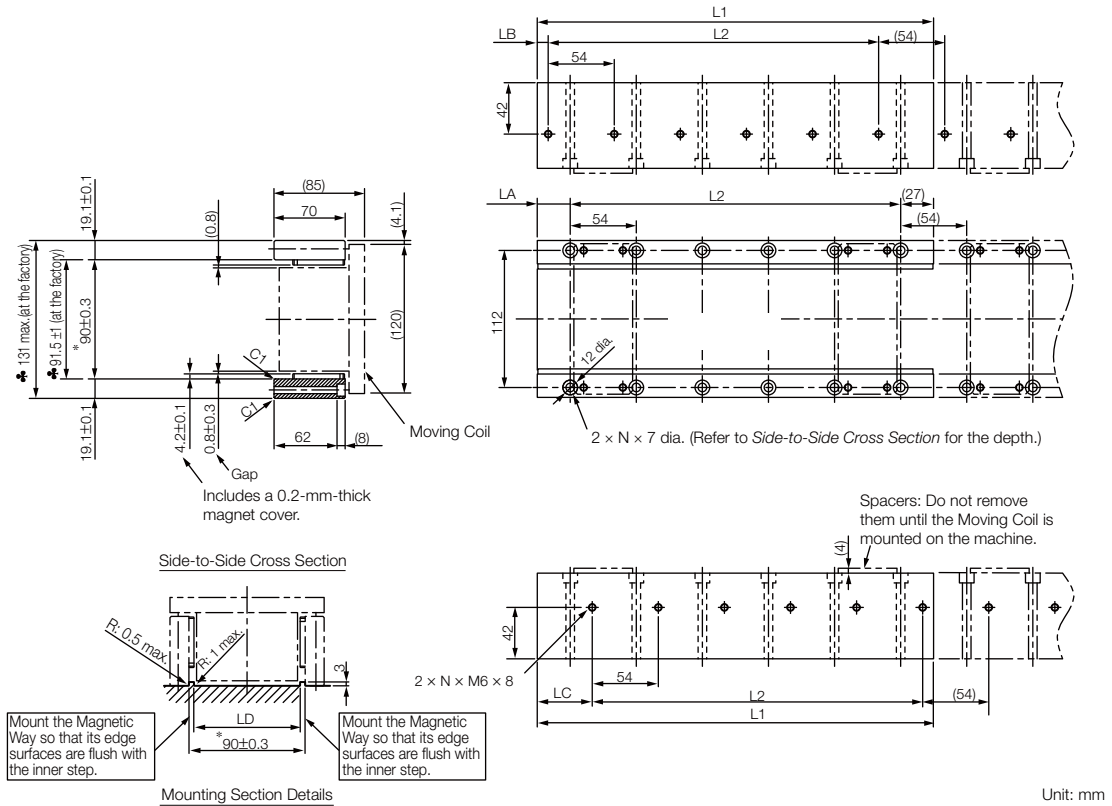

- Note: 1. Two Magnetic Way tracks are used together as a set. For safety, when they are shipped, the two tracks are secured to a mounting spacer made from aluminum.
2. More than one Magnetic Way can be connected.
3. Dimensions with asterisks are the distances between the Magnetic Way tracks. Install the tracks according to the specified dimensions. Observe the dimensions given in Mounting Section Details after installation. Dimensions when the Magnetic Way is shipped from the factory are indicated by ♣.
4. Use socket head screws of strength class 10.9 or higher for the Magnetic Way mounting screws. (Do not use stainless steel screws.)

Magnetic Way Model SGLTM-	L1	L2	LA	LB	LC	LD	N	Approx. Mass [kg]
50324H□	324 <sup>-0.1</sup> <sub>-0.3</sub>	270 (54 × 5)	27 <sup>0</sup> <sub>-0.2</sub>	9 <sup>0</sup> <sub>-0.2</sub>	45 <sup>0</sup> <sub>-0.2</sub>	82 <sup>+0.6</sup> <sub>0</sub>	6	8
50540H□	540 <sup>-0.1</sup> <sub>-0.3</sub>	486 (54 × 9)	27 <sup>0</sup> <sub>-0.2</sub>	9 <sup>0</sup> <sub>-0.2</sub>	45 <sup>0</sup> <sub>-0.2</sub>	82 <sup>+0.6</sup> <sub>0</sub>	10	13
50756H□	756 <sup>-0.1</sup> <sub>-0.3</sub>	702 (54 × 13)	27 <sup>0</sup> <sub>-0.2</sub>	9 <sup>0</sup> <sub>-0.2</sub>	45 <sup>0</sup> <sub>-0.2</sub>	82 <sup>+0.6</sup> <sub>0</sub>	14	18



## SGLTW-80: Standard Models

### ◆ Moving Coils: SGLTW-80A□□□B□

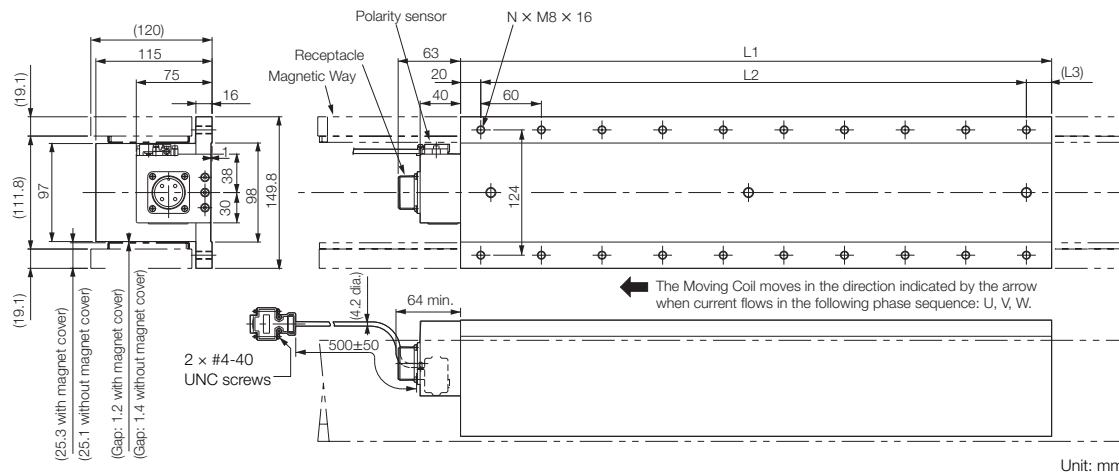

Moving Coil Model SGLTW-	L1	L2	(L3)	N	Approx. Mass [kg]
80A400B□	394.2	360 (60 × 6)	(15)	14	24
80A600B□	574.2	540 (60 × 9)	(15)	20	35

Refer to the following section for the connector specifications for the Sensor Cable and Servo Motor Main Circuit Cable.

☞ SGLTW-40A□□□B□ and -80A□□□B□ Moving Coils (page 257)

◆ Magnetic Ways: SGLTM-80□□□A□

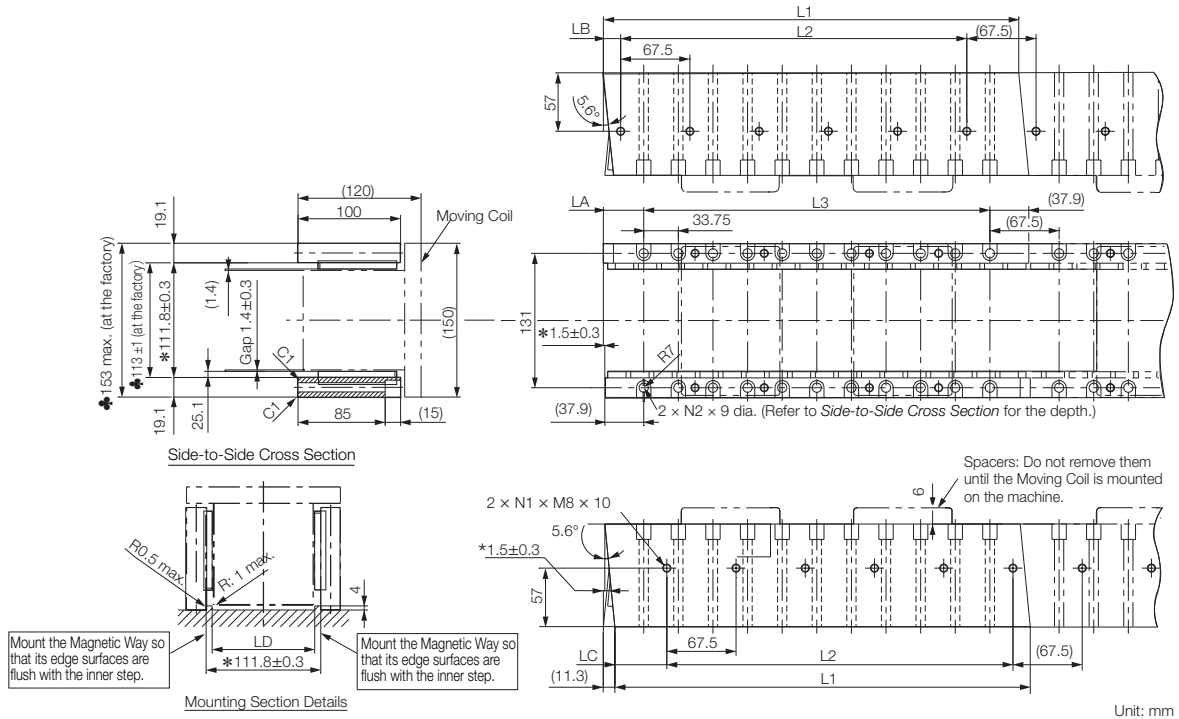

Unit: mm

- Note: 1. Two Magnetic Way tracks are used together as a set. For safety, when they are shipped, the two tracks are secured to a mounting spacer made from aluminum.
2. More than one Magnetic Way can be connected.
3. Dimensions with asterisks are the distances between the Magnetic Way tracks. Install the tracks according to the specified dimensions. Observe the dimensions given in Mounting Section Details after installation. Dimensions when the Magnetic Way is shipped from the factory are indicated by ♣.
4. Use socket head screws of strength class 10.9 or higher for the Magnetic Way mounting screws. (Do not use stainless steel screws.)

Magnetic Way Model SGLTM-	L1	L2	L3	LA	LB	LC	LD	N1	N2	Approx. Mass [kg]
80405A□	405 <sup>-0.1</sup> <sub>-0.3</sub>	337.5 (67.5 × 5)	337.5 (33.75 × 10)	39.4 <sup>0</sup> <sub>-0.2</sub>	16.9 <sup>0</sup> <sub>-0.2</sub>	50.6 <sup>0</sup> <sub>-0.2</sub>	100 <sup>+0.6</sup> <sub>0</sub>	6	11	14
80675A□	675 <sup>-0.1</sup> <sub>-0.3</sub>	607.5 (67.5 × 9)	607.5 (33.75 × 18)	39.4 <sup>0</sup> <sub>-0.2</sub>	16.9 <sup>0</sup> <sub>-0.2</sub>	50.6 <sup>0</sup> <sub>-0.2</sub>	100 <sup>+0.6</sup> <sub>0</sub>	10	19	24
80945A□	945 <sup>-0.1</sup> <sub>-0.3</sub>	877.5 (67.5 × 13)	887.5 (33.75 × 26)	39.4 <sup>0</sup> <sub>-0.2</sub>	16.9 <sup>0</sup> <sub>-0.2</sub>	50.6 <sup>0</sup> <sub>-0.2</sub>	100 <sup>+0.6</sup> <sub>0</sub>	14	27	34

◆ Magnetic Ways with Bases: SGLTM-80□□□AY

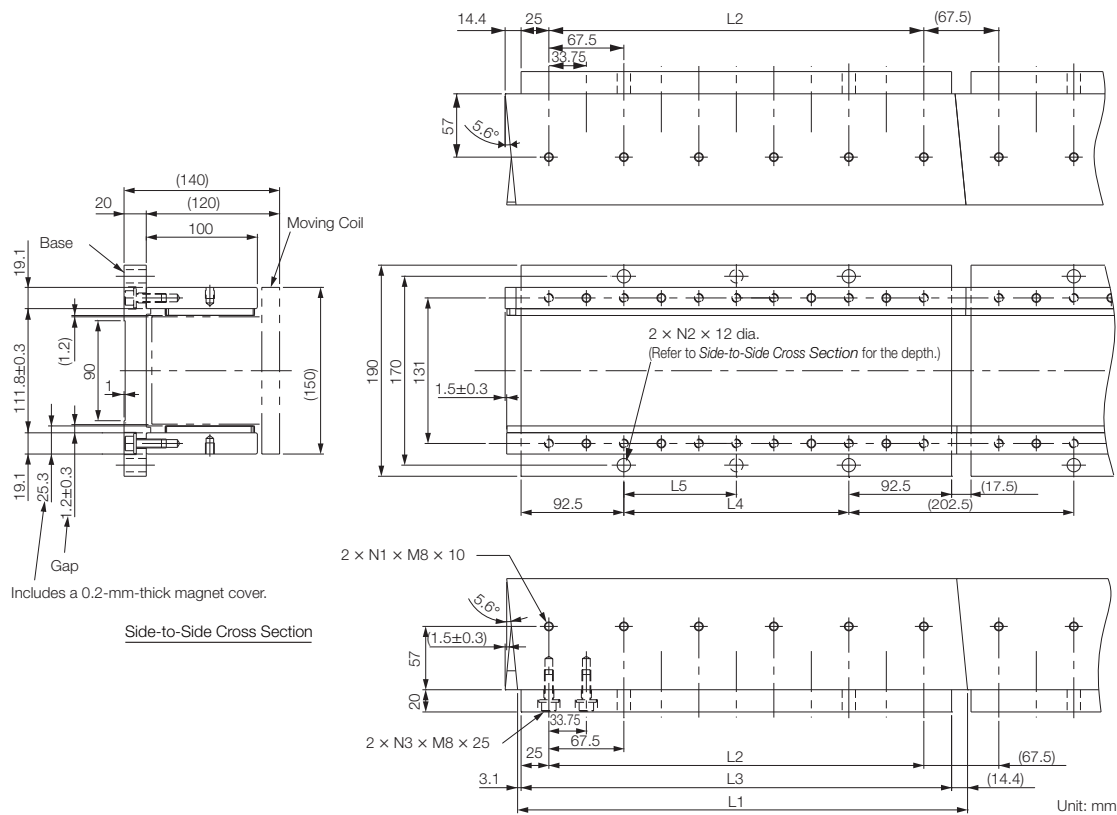

Note: Two Magnetic Way tracks are used together as a set. More than one Magnetic Way can be connected.

Magnetic Way Model SGLTM-	L1	L2	L3	L4	L5	N1	N2	N3	Approx. Mass [kg]
80405AY	405 <sup>-0.1</sup> <sub>-0.3</sub>	337.5	387.5	202.5	202.5	6	2	11	18
80675AY	675 <sup>-0.1</sup> <sub>-0.3</sub>	607.5	657.5	472.5	236.25	10	3	19	31
80945AY	945 <sup>-0.1</sup> <sub>-0.3</sub>	877.5	927.5	742.5	247.5	14	4	27	43

## Connector Specifications

### ◆ SGLTW-20A□□□ A□ and -35A□□□ A□ Moving Coils

- Servo Motor Connector

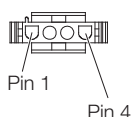

Plug: 350779-1  
 Pins: 350218-3 or 350547-3 (No.1 to 3)  
 350654-1 or 350669-1 (No. 4)  
 Tyco Electronics Japan G.K.

Mating Connector  
 Cap: 350780-1  
 Socket: 350537-3 or 350550-3

- Polarity Sensor Connector



Pin connector: 17JE-23090-02 (D8C) -CG  
 From DDK Ltd.

Mating Connector  
 Socket connector: 17JE-13090-02 (D8C) A-CG  
 Studs: 17L-002C or 17L-002C1

- Polarity Sensor Output Signal

The figure on the right shows the relationship between the Su, Sv, and Sw polarity sensor output signals and the inverse power of each motor phase Vu, Vv, and Vw when the Moving Coil moves in the direction indicated by the arrow in the dimensional drawings of the Moving Coil.

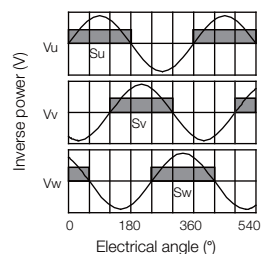

◆ SGLTW-40A□□□ B□ and -80A□□□ B□ Moving Coils

• Servo Motor Connector



Receptacle: MS3102A-22-22P  
From DDK Ltd.

Mating Connector  
Right-angle plug: MS3108B22-22S  
Straight plug: MS3106B22-22S  
Cable clamp: MS3057-12A

• Polarity Sensor Connector



Pin connector: 17JE-23090-02 (D8C) -CG  
From DDK Ltd.

Mating Connector  
Socket connector: 17JE-13090-02 (D8C) A-CG  
Studs: 17L-002C or 17L-002C1

• Polarity Sensor Output Signal

The figure on the right shows the relationship between the Su, Sv, and Sw polarity sensor output signals and the inverse power of each motor phase Vu, Vv, and Vw when the Moving Coil moves in the direction indicated by the arrow in the dimensional drawings of the Moving Coil.

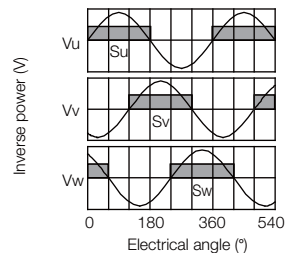

## Linear Servo Motors

SGLT (Models with T-type Iron Cores)

### ◆ SGLTW-35A□□□ H□ and -50A□□□ H□ Moving Coils

#### • Moving Coil Lead

Secure the lead from the Moving Coil of the Linear Servo Motor so that it moves together with the Moving Coil.

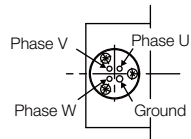

(Viewed from the top surface of the Moving Coil.)

#### • Polarity Sensor Connector



Pin connector: 17JE-23090-02 (D8C) -CG  
From DDK Ltd.

Mating Connector

Socket connector: 17JE-13090-02 (D8C) A-CG  
Studs: 17L-002C or 17L-002C1

#### • Polarity Sensor Output Signal

The figure on the right shows the relationship between the  $S_u$ ,  $S_v$ , and  $S_w$  polarity sensor output signals and the inverse power of each motor phase  $V_u$ ,  $V_v$ , and  $V_w$  when the Moving Coil moves in the direction indicated by the arrow in the dimensional drawings of the Moving Coil.

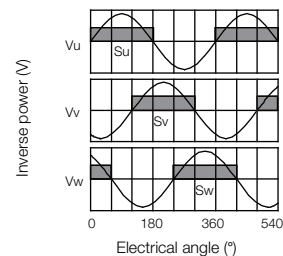

## Cables for Linear Servo Motors

### ◆ System Configurations

Example: SGLTW Servo Motors with T-type Iron Cores

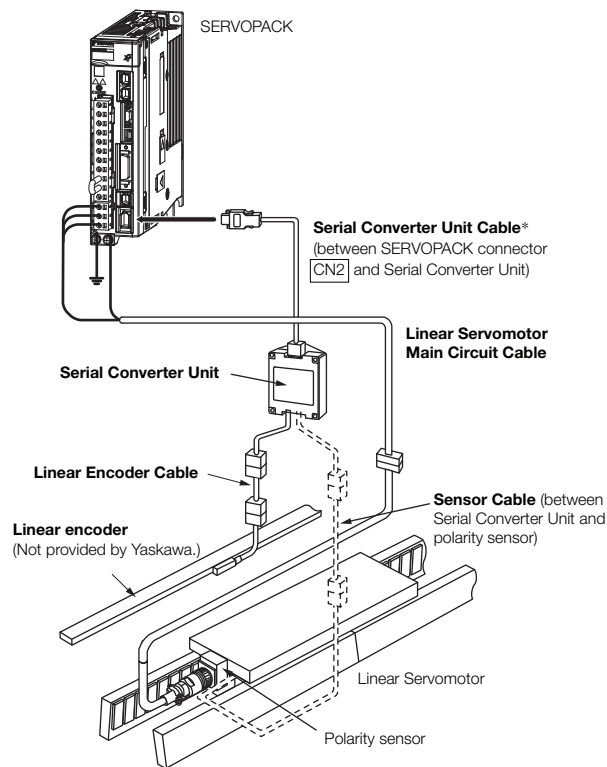

\* You can connect directly to an absolute linear encoder.

Note: 1. The above system configurations are for SGLTW Servo Motors with T-type Iron Cores. Refer to the manual for the Linear Servo Motor for configurations with other models.

2. Refer to the following manual for the following information.

- Cable dimensional drawings and cable connection specifications
- Order numbers and specifications of individual connectors for cables
- Order numbers and specifications for wiring materials

📖 *Σ-7-Series AC Servo Drive Peripheral Device Selection Manual* (Manual No.: SIEP S800001 32)

## Linear Servo Motors

SGLT (Models with T-type Iron Cores)

### Servo Motor Main Circuit Cables

Servo Motor Model	Length (L)	Order Number	Appearance
SGLTW-20A, -35A	1 m	JZSP-CLN21-01-E	
	3 m	JZSP-CLN21-03-E	
	5 m	JZSP-CLN21-05-E	
	10 m	JZSP-CLN21-10-E	
	15 m	JZSP-CLN21-15-E	
	20 m	JZSP-CLN21-20-E	
SGLTW-□□A□□□□□□□□	1 m	JZSP-CLN14-01-E	
	3 m	JZSP-CLN14-03-E	
	5 m	JZSP-CLN14-05-E	
	10 m	JZSP-CLN14-10-E	
	15 m	JZSP-CLN14-15-E	
	20 m	JZSP-CLN14-20-E	
SGLTW-40□□□□□B□ -80□□□□□B□	1 m	JZSP-CLN39-01-E	
	3 m	JZSP-CLN39-03-E	
	5 m	JZSP-CLN39-05-E	
	10 m	JZSP-CLN39-10-E	
	15 m	JZSP-CLN39-15-E	
	20 m	JZSP-CLN39-20-E	

Note: Shaded model numbers are non-stock items

\*1. Connector from Tyco Electronics Japan G.K.

\*2. Connector from Interconnectron GmbH

\*3. A connector is not provided on the Linear Servo Motor end. Obtain a connector according to your specifications. Refer to the next page for information on connectors.



## JZSP-CLN39-□ □ -E Cables

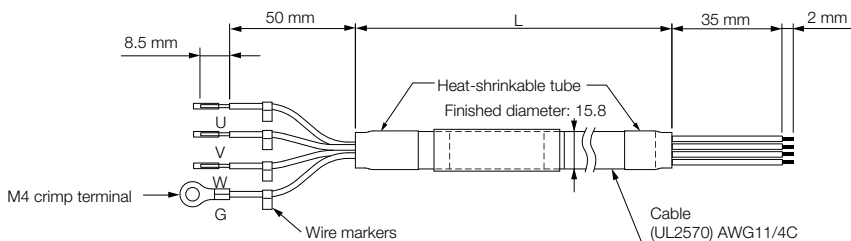

### ◆ Wiring Specifications

SERVOPACK Leads		Servo Motor Connector	
Wire Color	Signal	Signal	Pin
Red	Phase U	Phase U	A
White	Phase V	Phase V	B
Blue	Phase W	Phase W	C
Green/yellow	FG	FG	D

### ◆ JZSP-CLN39 Cable Connectors

Applicable Servo Motor	Connector Provided with Servo Motor	Plug		Cable Clamp
		Straight	Right-angle	
SGLTW-40 and -80	MS3102A22-22P	MS3106B22-22S or MS3106A22-22S	MS3108B22-22S	MS3057-12A

### ◆ MS3106B22-2S: Straight Plug with Two-piece Shell

Unit: mm

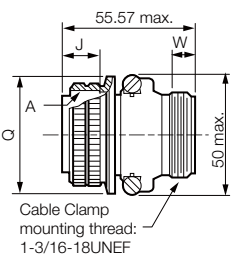

Shell Size	Joint Thread A	Length of Joint J ±0.12	Joint Nut Outer Diameter Q <sup>+0</sup> / <sub>-0.38</sub>	Effective Thread Length W min.
22	1-3/8-18UNEF	18.26	40.48	9.53

### ◆ MS3106A22-2S: Straight Plug with Solid Shell

Unit: mm

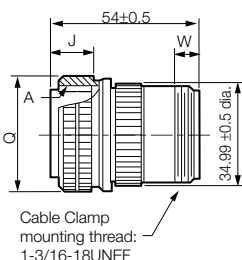

Shell Size	Joint Thread A	Length of Joint J ±0.12	Joint Nut Outer Diameter Q <sup>+0</sup> / <sub>-0.38</sub>	Effective Thread Length W min.
22	1-3/8-18UNEF	18.26	40.48	9.53

## Linear Servo Motors

SGLT (Models with T-type Iron Cores)

### ◆ MS3108B22-2S: Right-angle Plug with Two-piece Shell

Unit: mm

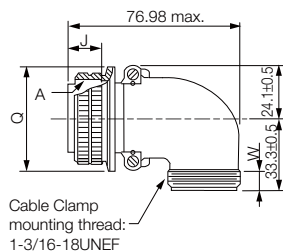

Shell Size	Joint Thread A	Length of Joint $J \pm 0.12$	Joint Nut Outer Diameter $Q \begin{smallmatrix} +0 \\ -0.38 \end{smallmatrix}$	Effective Thread Length W min.
22	1-3/8-18UNEF	18.26	40.48	9.53

### ◆ Dimensional Drawings: MS3057-12A Cable Clamp with Rubber Bushing

Unit: mm

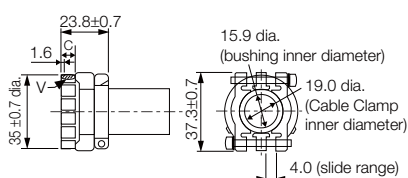

Applicable Connector Shell Size	Effective Thread Length C	Mounting Thread V	Attached Bushing
20.22	10.3	1-3/16-18UNEF	AN3420-12

## Linear Encoder Cables

Name	Servo Motor Model	Length* (L)	Order Number	Appearance
For linear encoder from Renishaw PLC	All Models	1 m	JZSP-CLL00-01-E	
		3 m	JZSP-CLL00-03-E	
		5 m	JZSP-CLL00-05-E	
		10 m	JZSP-CLL00-10-E	
		15 m	JZSP-CLL00-15-E	
For linear encoder from Heidenhain Corporation		1 m	JZSP-CLL30-01-E	
		3 m	JZSP-CLL30-03-E	
		5 m	JZSP-CLL30-05-E	
		10 m	JZSP-CLL30-10-E	
		15 m	JZSP-CLL30-15-E	

\* When using a JZDP-J00□-□□□-E Serial Converter Unit, do not exceed a cable length of 3 m.

## Serial Converter Unit Cables

Servo Motor Model	Length (L)	Order Number	Appearance
All Models	1 m	JZSP-CLP70-01-E	
	3 m	JZSP-CLP70-03-E	
	5 m	JZSP-CLP70-05-E	
	10 m	JZSP-CLP70-10-E	
	15 m	JZSP-CLP70-15-E	
	20 m	JZSP-CLP70-20-E	

## Sensor Cables

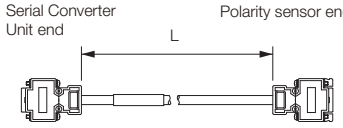
Servo Motor Model	Length (L)	Order Number	Appearance
SGLTW-□□A	1 m	JZSP-CLL10-01-E	 <p>Serial Converter Unit end      Polarity sensor end</p> <p style="text-align: center;">L</p>
	3 m	JZSP-CLL10-03-E	
	5 m	JZSP-CLL10-05-E	
	10 m	JZSP-CLL10-10-E	
	15 m	JZSP-CLL10-15-E	

# Serial Converters Units

## Selection Table (Model Designations)

Use the following tables to select the Serial Converter Unit.

JZDP - □00□ - □□□

Serial Converter Unit Model			
Code	Appearance	Applicable Linear Encoder	Hall Sensor
D003		Manufactured by Heidenhain Corp.	None
G003			
D005		Manufactured by Renishaw PLC	None
G005			
D006		Manufactured by Heidenhain Corp.	Provided
G006			
D008		Manufactured by Renishaw PLC	Provided
G008			

Applicable Linear Servo Motor					
	Servo Motor Model		Servo Motor Model		Code
		Code		Code	
SGLGW - (coreless models) For Standard-force Magnetic Way	30A050C	250	20A170A	011	SGLTW- (models with T-type iron cores)
	30A080C	251	20A320A	012	
	40A140C	252	20A460A	013	
	40A253C	253	35A170A	014	
	40A365C	254	35A320A	015	
	60A140C	258	35A460A	016	
	60A253C	259	35A170H	105	
	60A365C	260	35A320H	106	
	90A200C	264	50A170H	108	
	90A370C	265	50A320H	109	
90A535C	266	40A400B	185	SGLFW- (models with F-type iron cores)	
SGLGW - + SGLGM - □-M (coreless models) For High-force Magnetic Way	40A140C	255	40A600B		186
	40A253C	256	80A400B		187
	40A365C	257	80A600B		188
	60A140C	261	35D170H		193
	60A253C	262	35D320H		194
	60A365C	263	50D170H		195
	20A090A	017	50D320H		196
	20A120A	018	40D400B		197
	35A120A	019	40D600B		198
	35A230A	020	80D400B	199	
	50A200B	181	80D600B	200	
	50A380B	182			
	1ZA200B	183			
	1ZA380B	184			
	35D120A	211			
	35D230A	212			
	50D200B	189			
	50D380B	190			
	1ZD200B	191			
	1ZD380B	192			

Note: 1. Refer to the following manual for detailed specifications of the Serial Converter Units.

Σ-7-Series AC Servo Drive Peripheral Device Selection Manual (Manual No.: SIEP S800001 32)

2. Shaded models are non-stock items.



# Recommended Linear Encoders

## Cable Configurations

The peripheral devices to obtain depend on whether the Linear Servo Motor has a polarity sensor, the manufacturer of the Linear Encoder, and the type of encoder. Refer to Recommended Linear Encoders (page M-11) for information on Linear Encoders that you can use with  $\Sigma$ -7-Series SERVOPACKs.

### Connections to Linear Encoder from Heidenhain Corporation

#### ◆ Connections for a 1 Vp-p Analog Voltage Output Signal

You must make the connections through a Yaskawa Serial Converter Unit. The output signal will be multiplied by 8 bits (256 divisions) or 12 bits (4,096 divisions) in the Serial Converter Unit.

#### ■ Connecting to a Linear Servo Motor with a Polarity Sensor

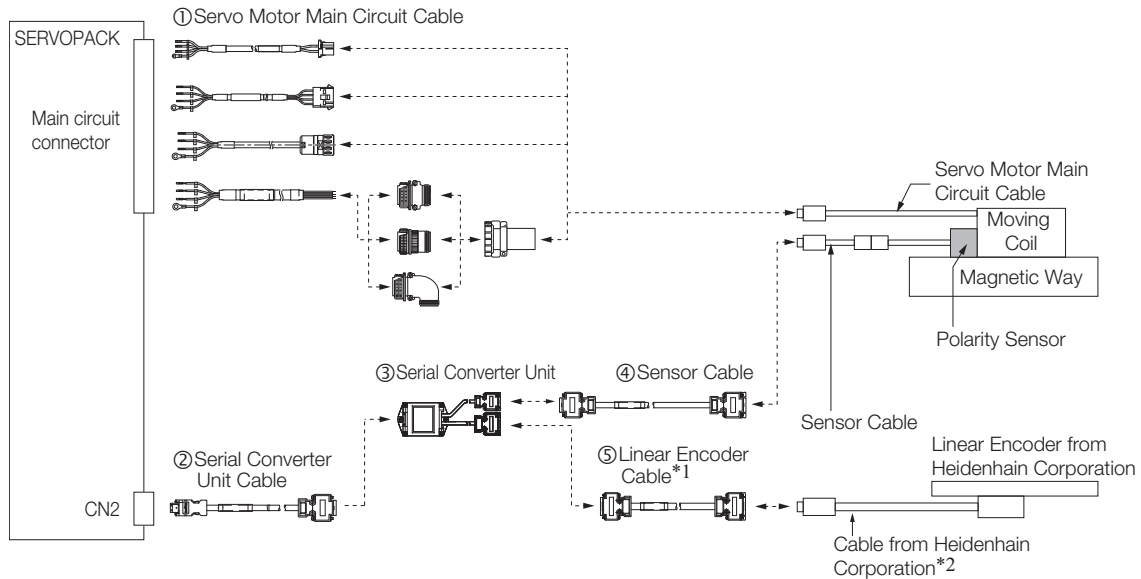

\*1. When using a JZDP-J00□□□□ Serial Converter Unit, do not use a Yaskawa Linear Encoder Cable that is longer than 3 m.

\*2. Contact Heidenhain Corporation for details on cables (analog 1 Vp-p output, D-sub 15-pin, male) from Heidenhain Corporation.

■ Connecting to a Linear Servo Motor without a Polarity Sensor

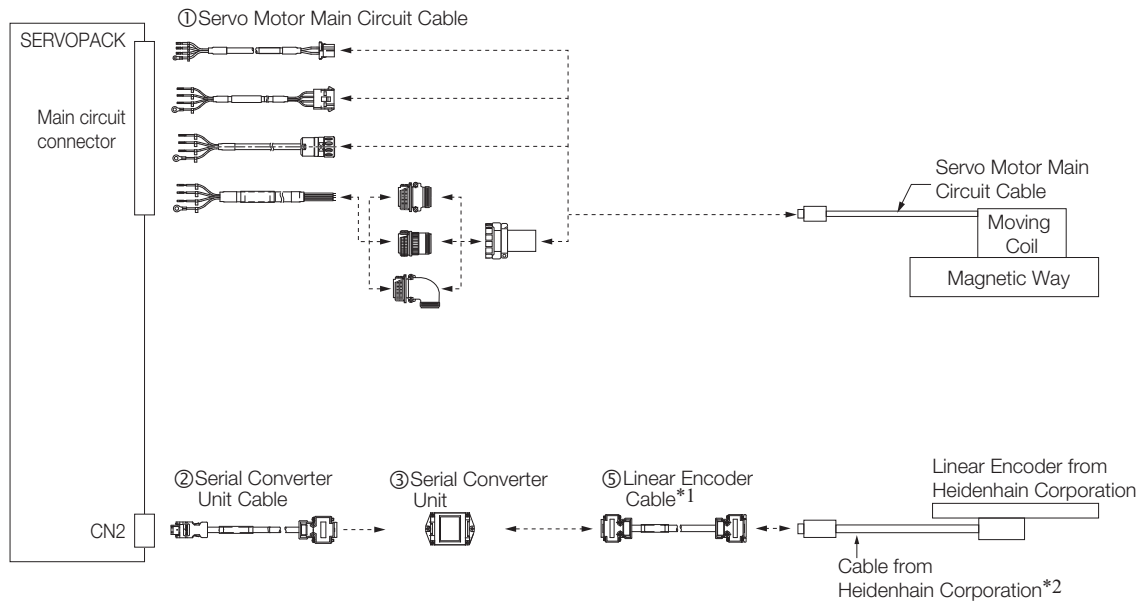

\*1. When using a JZDP-J00□□□□ Serial Converter Unit, do not use a Yaskawa Linear Encoder Cable that is longer than 3 m.

\*2. Contact Heidenhain Corporation for details on cables (analog 1 Vp-p output, D-sub 15-pin, male) from Heidenhain Corporation.

◆ LIC4100 Linear Encoder with EIB3391Y Interpolator

 Important

1. You cannot use an LIC4100 Linear Encoder together with a Linear Servo Motor with a Polarity Sensor.

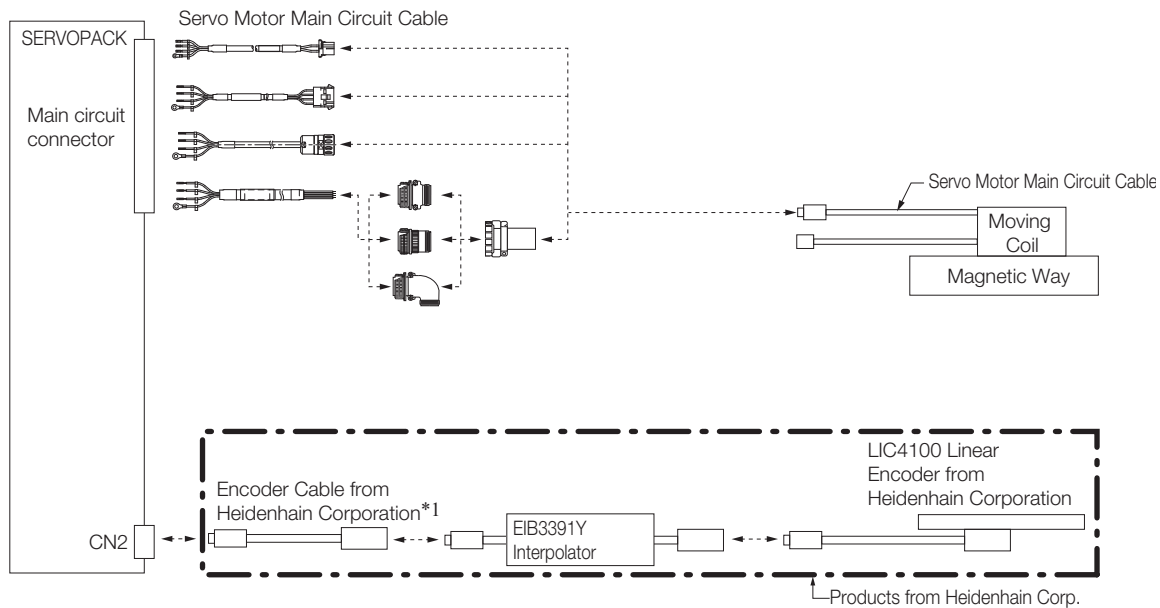

\*1. Use an Encoder Cable from Heidenhain Corporation. Contact Heidenhain Corporation for detailed Encoder Cable specifications.



## Connections to Linear Encoder from Renishaw plc

### ◆ Connections for a 1 Vp-p Analog Voltage Output Signal

You must make the connections through a Yaskawa Serial Converter Unit. The output signal will be multiplied by 8 bits (256 divisions) or 12 bits (4,096 divisions) in the Serial Converter Unit.

### ■ Connecting to a Linear Servo Motor with a Polarity Sensor

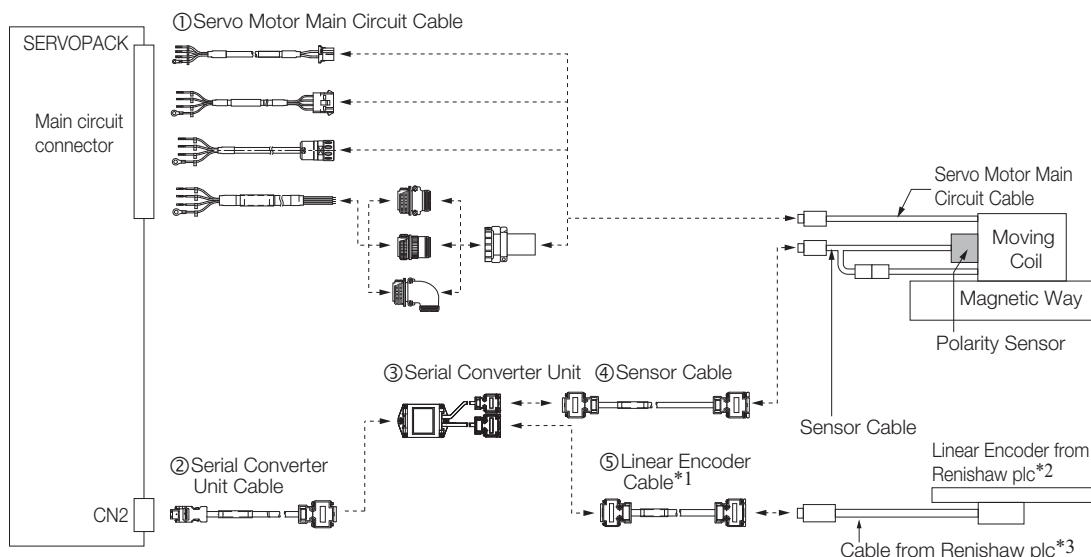

\*1. When using a JZDP-J00□-□□□ Serial Converter Unit, do not use a Yaskawa Linear Encoder Cable that is longer than 3 m.

\*2. If you use the origin signals with a Linear Encoder from Renishaw plc, the origin may sometimes be falsely detected. If that occurs, use the BID/DIR signal to output the origin signal only in one direction.

\*3. Contact Renishaw plc for details on cables (analog 1 Vp-p output, D-sub 15-pin, male) from Renishaw plc. However, the BID and DIR signals are not connected.

■ Connecting to a Linear Servo Motor without a Polarity Sensor

Servo Motors Other Than the SGLFW2

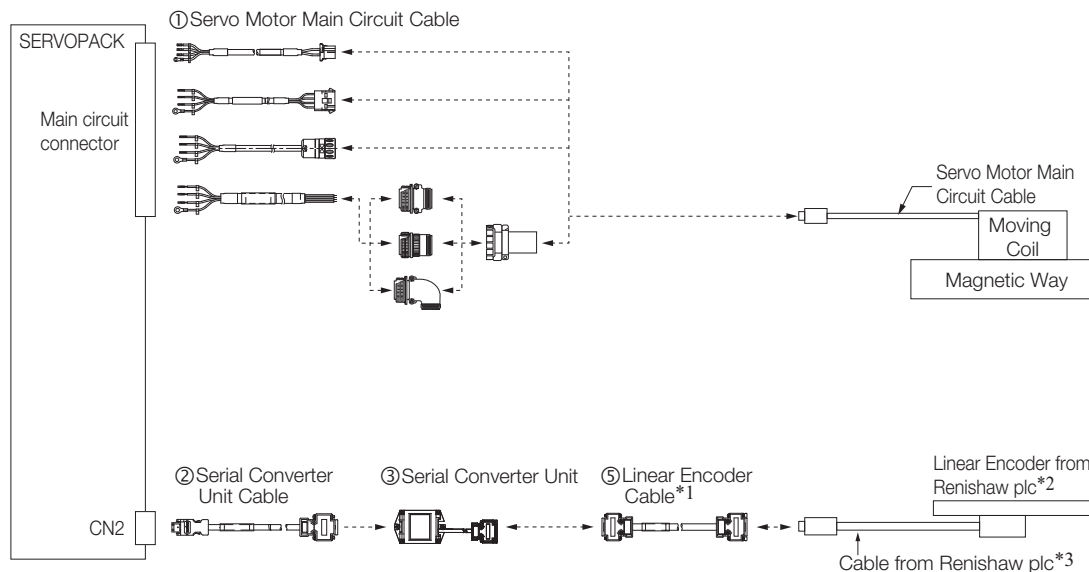

- \*1. When using a JZDP-J00□-□□□ Serial Converter Unit, do not use a Yaskawa Linear Encoder Cable that is longer than 3 m.
- \*2. If you use the origin signals with a Linear Encoder from Renishaw plc, the origin may sometimes be falsely detected. If that occurs, use the BID/DIR signal to output the origin signal only in one direction.
- \*3. Contact Renishaw plc for details on cables (analog 1 Vp-p output, D-sub 15-pin, male) from Renishaw plc. However, the BID and DIR signals are not connected.

## Connections to Linear Encoder from Magescale Co., Ltd.

### ◆ SL7□0 Linear Encoder and PL101-RY Sensor Head with Interpolator



**Important**

1. You cannot use a PL101-RY Sensor Head with an Interpolator together with a Linear Servo Motor with a Polarity Sensor.

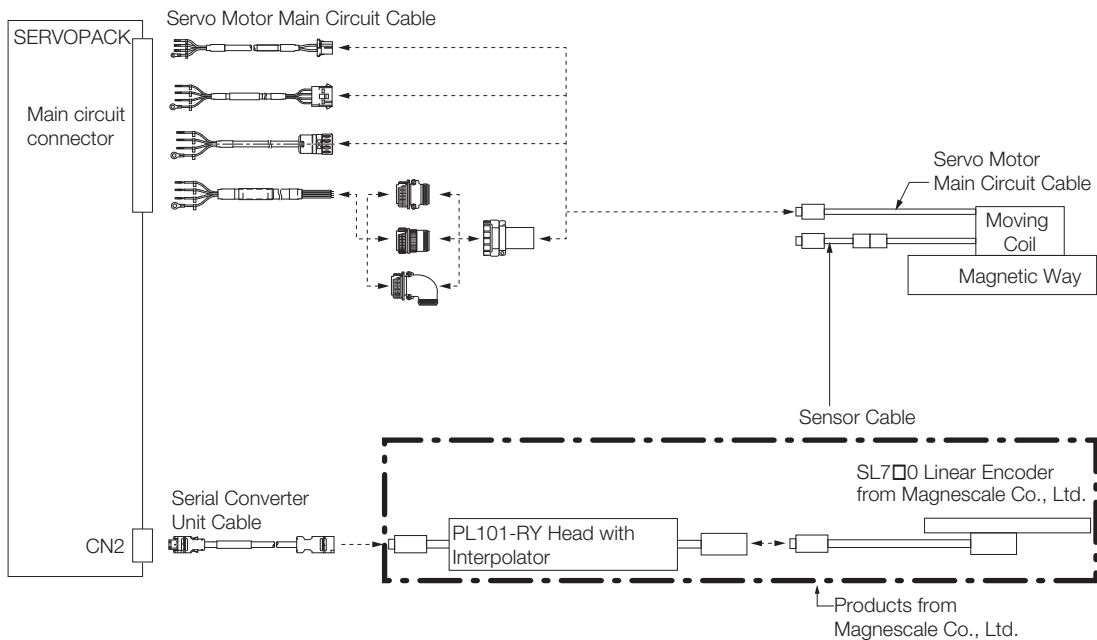

\*1. Cables to connect to the host controller are not provided by Yaskawa.  
Refer to the following manual for information on connector models.

📖 *Σ-7-Series AC Servo Drive Peripheral Device Selection Manual* (Manual No.: SIEP S80001 32)

◆ SL7□0 Linear Encoder, PL101 Sensor Head, and MJ620-T13 Interpolator



1. A 5-VDC power supply is required for the MJ620-T13. (The 5-VDC power supply is not provided by Yaskawa.)
2. Refer to the MJ620-T13 specifications from Magnescale Co., Ltd. for the current consumption of the MJ620-T13.

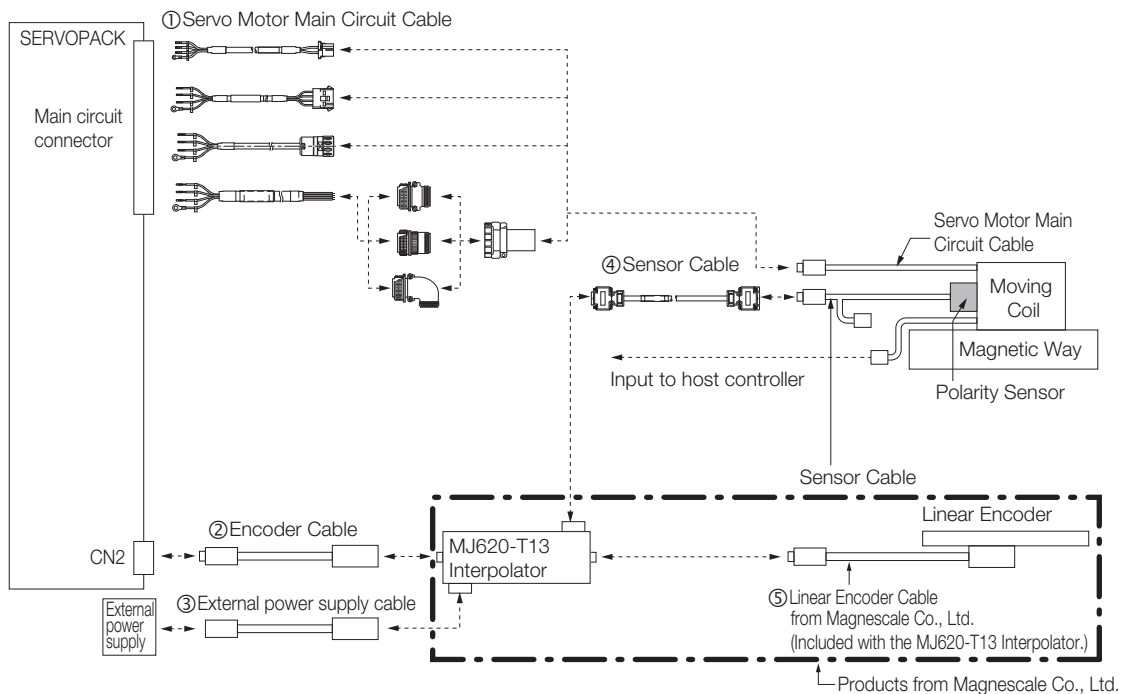

■ Encoder Cables

These cables are not provided by Yaskawa. Use a shielded cable. Refer to the following tables for the pin layouts.

**SERVOPACK End of Cable (CN2)**

- Plug Connector: 55100-0670 (Molex Japan Co., Ltd)
- Connector order number: JZSP-CMP9-1-E (SERVOPACK Connector Kit)

Pin	Signal	Function
1	–	–
2	PG0 V	Encoder power supply 0 V
3	–	–
4	–	–
5	PS	Serial data
6	/PS	
Shell	Shield	–

**MJ620-T13 End of Cable**

For details, refer to the specifications for the MJ620-T13 from Magnescale Co., Ltd..

- Receptacle: PCR-E20LMD+ (Honda Tsushin Kogyo Co., Ltd.)
- Plug: PCR-E20FS+ (Honda Tsushin Kogyo Co., Ltd.)
- Shell: PCS-E20L□(Honda Tsushin Kogyo Co., Ltd.)

Pin	Signal	Function	Pin	Signal	Function
1	Do not connect.	–	12	0 V	0 V
2	Do not connect.	–	13	Do not connect.	–
3	Do not connect.	–	14	0 V	0 V
4	Do not connect.	–	15	Do not connect.	–
5	SD	Serial data	16	0 V	0 V
6	/SD		17	Do not connect.	–
7	Do not connect.	–	18	Do not connect.	–
8	Do not connect.	–	19	Do not connect.	–
9	Do not connect.	–	20	Do not connect.	–
10	Do not connect.	–	Shell	Shield	–
11	Do not connect.	–			

**Cables without Connectors**

Name	Length (L)	Order Number	
		Standard Cable	Flexible Cable
Cables without Connectors	5 m	JZSP-CMP09-05-E	JZSP-CSP39-05-E
	10 m	JZSP-CMP09-10-E	JZSP-CSP39-10-E
	15 m	JZSP-CMP09-15-E	JZSP-CSP39-15-E
	20 m	JZSP-CMP09-20-E	JZSP-CSP39-20-E

Note: We recommend that you use Flexible Cables.

## Linear Servo Motors

### Recommended Linear Encoders

#### ■ External Power Supply Cables

This cable is not provided by Yaskawa. Refer to the table on the right for the pin layout.

Pin	Signal	Function
1	+5 V	+5 V
2	0 V	0 V

For details, refer to the specifications for the MJ620-T13 from Magnescale Co., Ltd..

- Connector Header: MC1.5/2-GF-3.81 (Phoenix Contact)
- Connector Plug: MC1.5/2-STF-3.81 (Phoenix Contact)

#### ◆ SR-75, SR-77, SR-85, and SR-87 Linear Encoders



1. You cannot use an SR-75, SR-77, SR-85, or SR-87 Linear Encoder with a Linear Servo Motor with a Polarity Sensor.

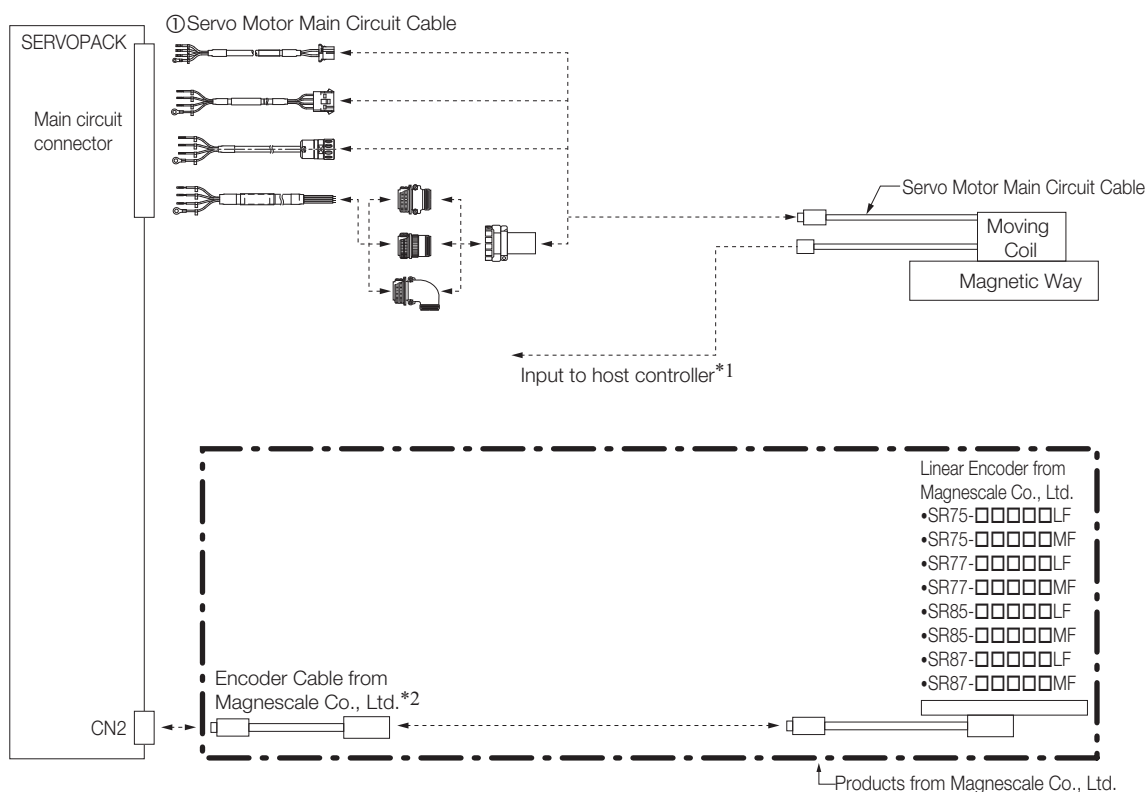

\*1. Cables to connect to the host controller are not provided by Yaskawa. Refer to the following manual for information on connector models.

📖 *Σ-7-Series AC Servo Drive Peripheral Device Selection Manual* (Manual No.: SIEP S800001 32)

\*2. To connect the SERVOPACK and Linear Encoder, use a CH33-xx□□□ Cable from Magnescale Co., Ltd. (This cable has connectors designed for use with Yaskawa products.)

## Connections to Linear Encoders from Mitutoyo Corporation

### ◆ ST78□A Linear Encoders



**1. You cannot use a ST78□A Linear Encoder together with a Linear Servo Motor with a Polarity Sensor.**

Important

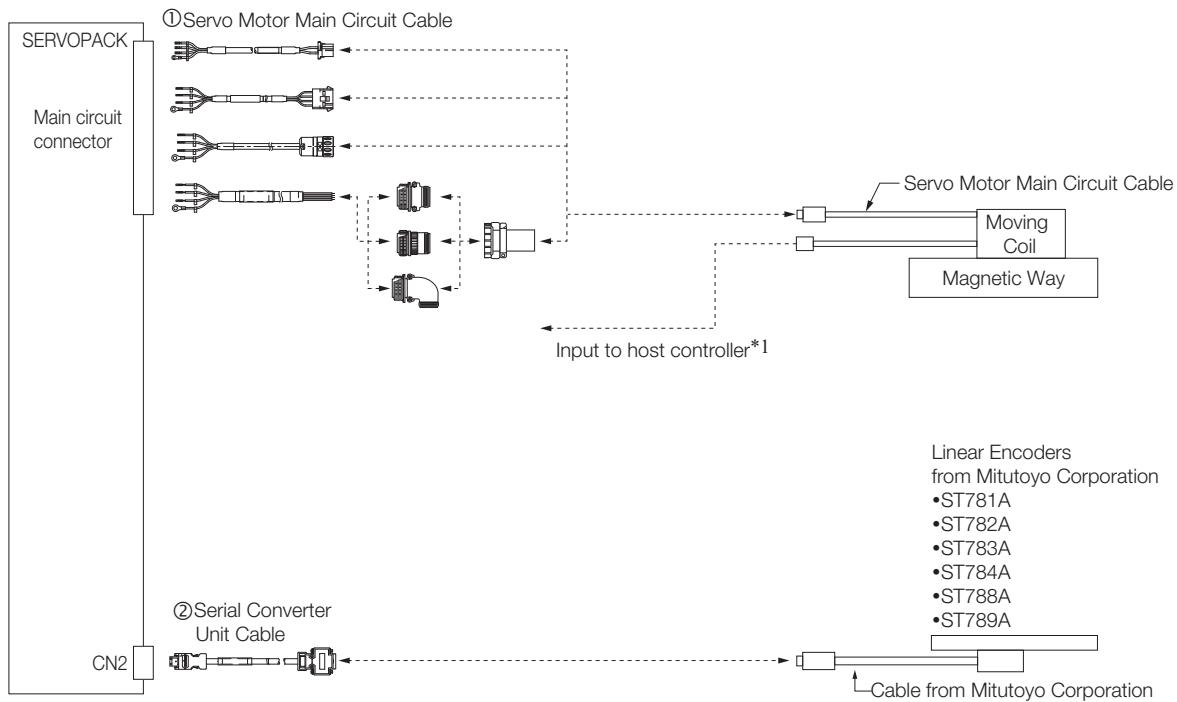

\*1. Cables to connect to the host controller are not provided by Yaskawa. Refer to the following manual for information on connector models.

📖 *Σ-7-Series AC Servo Drive Peripheral Device Selection Manual* (Manual No.: SIEP S800001 32)

## Linear Servo Motors

Recommended Linear Encoders

---



# SERVOPACKs

---

$\Sigma$ -7S Single-axis Analog Voltage/Pulse Train  
Reference SERVOPACKs .....278

$\Sigma$ -7S Single-axis MECHATROLINK-III Communications  
Reference SERVOPACKs .....288

$\Sigma$ -7S Single-axis EtherCAT  
Communications Reference SERVOPACKs .....298

$\Sigma$ -7W Two-axis MECHATROLINK-III  
Communications Reference SERVOPACKs .....308

SERVOPACK External Dimensions .....316

# Σ-7S Single-axis Analog Voltage/Pulse Train Reference SERVOPACKs

## Model Designations

SGD7S - R70 A 00 A

Σ-7 Series  
Σ-7S SERVOPACKs
1st+2nd+3rd  
digits
4th  
digit
5th+6th  
digits
7th  
digit

**1st+2nd+3rd digits** Maximum Applicable Motor Capacity

Voltage	Code	Specification
Three-phase, 200 VAC	R70* <sup>1</sup>	0.05 kW
	R90* <sup>1</sup>	0.1 kW
	1R6* <sup>1</sup>	0.2 kW
	2R8* <sup>1</sup>	0.4 kW
	3R8	0.5 kW
	5R5* <sup>1</sup>	0.75 kW
	7R6	1.0 kW
	120* <sup>3</sup>	1.5 kW
	180	2.0 kW
	200	3.0 kW
	330	5.0 kW
470	6.0 kW	
550	7.5 kW	
590	11 kW	
780	15 kW	
Single-phase, 100 VAC	R70	0.05 kW
	R90	0.1 kW
	2R1	0.2 kW
	2R8	0.4 kW

**4th digit** Voltage

Code	Specification
A	200 VAC
F	100 VAC

**5th+6th digits** Interface\*<sup>2</sup>

Code	Specification
00	Analog voltage/pulse train reference

**7th digit** Design Revision Order

A

- \*1. You can use these models with either a single-phase or three-phase power supply input.
- \*2. The same SERVOPACKs are used for both Rotary Servo Motors and Linear Servo Motors.
- \*3. A model with a single-phase, 200-VAC power supply input is available as a hardware option (model: SGD7S-120A00A008).

## Ratings and Specifications

### Ratings

#### ◆ Single-phase, 100 VAC

Model SGD7S-		R70F	R90F	2R1F	2R8F
Maximum Applicable Motor Capacity [kW]		0.05	0.1	0.2	0.4
Continuous Output Current [Arms]		0.66	0.91	2.1	2.8
Instantaneous Maximum Output Current [Arms]		2.1	3.2	6.5	9.3
Main Circuit	Power Supply	100 VAC to 120 VAC, -15% to +10%, 50/60 Hz			
	Input Current [Arms]*	1.5	2.5	5	10
Control Power Supply		100 VAC to 120 VAC, -15% to +10%, 50/60 Hz			
Power Supply Capacity [kVA]*		0.2	0.3	0.6	1.4
Power Loss*	Main Circuit Power Loss [W]	5.3	7.8	14.2	26.2
	Control Circuit Power Loss [W]	12	12	12	12
	Total Power Loss [W]	17.3	19.8	26.2	38.2
Regenerative Resistor	Minimum Allowable External Resistance [ $\Omega$ ]	40	40	40	40
Overvoltage Category		III			

\* This is the net value at the rated load.

#### ◆ Three-phase, 200 VAC

Model SGD7S-		R70A	R90A	1R6A	2R8A	3R8A	5R5A	7R6A	120A	180A	200A	330A	
Maximum Applicable Motor Capacity [kW]		0.05	0.1	0.2	0.4	0.5	0.75	1.0	1.5	2.0	3.0	5.0	
Continuous Output Current [Arms]		0.66	0.91	1.6	2.8	3.8	5.5	7.6	11.6	18.5	19.6	32.9	
Instantaneous Maximum Output Current [Arms]		2.1	3.2	5.9	9.3	11	16.9	17	28	42	56	84.0	
Main Circuit	Power Supply	200 VAC to 240 VAC, -15% to +10%, 50 Hz/60 Hz											
	Input Current [Arms]*	0.4	0.8	1.3	2.5	3.0	4.1	5.7	7.3	10	15	25	
Control Power Supply		200 VAC to 240 VAC, -15% to +10%, 50 Hz/60 Hz											
Power Supply Capacity [kVA]*		0.2	0.3	0.5	1.0	1.3	1.6	2.3	3.2	4.0	5.9	7.5	
Power Loss*	Main Circuit Power Loss [W]	5.1	7.3	13.5	24.0	20.1	43.8	53.6	65.8	111.9	113.8	263.7	
	Control Circuit Power Loss [W]	17	17	17	17	17	17	17	22	22	22	27	
	Built-in Regenerative Resistor Power Loss [W]	-	-	-	-	8	8	8	10	16	16	36.0	
	Total Power Loss [W]	22.1	24.3	30.5	41.0	45.1	68.8	78.6	97.8	149.9	151.8	326.7	
Regenerative Resistor	Built-In Regenerative Resistor	Resistance [ $\Omega$ ]	-	-	-	-	40	40	40	20	12	12	8
		Capacity [W]	-	-	-	-	40	40	40	60	60	60	180
	Minimum Allowable External Resistance [ $\Omega$ ]	40	40	40	40	40	40	40	40	20	12	12	8
Overvoltage Category		III											

\* This is the net value at the rated load.

## SERVOPACKs

### Σ-7S Single-axis Analog Voltage/Pulse Train Reference SERVOPACKs

Model SGD7S-		470A	550A	590A	780A
Maximum Applicable Motor Capacity [kW]		6.0	7.5	11	15
Continuous Output Current [Arms]		46.9	54.7	58.6	78.0
Instantaneous Maximum Output Current [Arms]		110	130	140	170
Main Circuit	Power Supply	200 VAC to 240 VAC, -15% to +10%, 50 Hz/60 Hz			
	Input Current [Arms] <sup>*1</sup>	29	37	54	73
Control Power Supply		200 VAC to 240 VAC, -15% to +10%, 50 Hz/60 Hz			
Power Supply Capacity [kVA] <sup>*1</sup>		10.7	14.6	21.7	29.6
Power Loss <sup>*1</sup>	Main Circuit Power Loss [W]	279.4	357.8	431.7	599.0
	Control Circuit Power Loss [W]	33	33	48	48
	External Regenerative Resistor Unit Power Loss [W]	180 <sup>*2</sup>	180 <sup>*3</sup>	350 <sup>*3</sup>	350 <sup>*3</sup>
	Total Power Loss [W]	312.4	390.8	479.7	647.0
External Regenerative Resistor Unit	External Regenerative Resistor Unit	Resistance [Ω ]	6.25 <sup>*2</sup>	3.13 <sup>*3</sup>	3.13 <sup>*3</sup>
		Capacity [W]	880 <sup>*2</sup>	1760 <sup>*3</sup>	1760 <sup>*3</sup>
	Minimum Allowable External Resistance [Ω ]	5.8	2.9	2.9	2.9
Overvoltage Category		III			

\*1. This is the net value at the rated load.

\*2. This value is for the optional JUSP-RA04-E Regenerative Resistor Unit.

\*3. This value is for the optional JUSP-RA05-E Regenerative Resistor Unit.

### ◆ Single-phase, 200 VAC

Model SGD7S-		R70A	R90A	1R6A	2R8A	5R5A
Maximum Applicable Motor Capacity [kW]		0.05	0.1	0.2	0.4	0.75
Continuous Output Current [Arms]		0.66	0.91	1.6	2.8	5.5
Instantaneous Maximum Output Current [Arms]		2.1	3.2	5.9	9.3	16.9
Main Circuit	Power Supply	200 VAC to 240 VAC, -15% to +10%, 50 Hz/60 Hz				
	Input Current [Arms] <sup>*</sup>	0.8	1.6	2.4	5.0	8.7
Control Power Supply		200 VAC to 240 VAC, -15% to +10%, 50 Hz/60 Hz				
Power Supply Capacity [kVA] <sup>*</sup>		0.2	0.3	0.6	1.2	1.9
Power Loss <sup>*</sup>	Main Circuit Power Loss [W]	5.1	7.3	13.5	24.0	43.8
	Control Circuit Power Loss [W]	17	17	17	17	17
	Built-in Regenerative Resistor Power Loss [W]	-	-	-	-	8
	Total Power Loss [W]	22.1	24.3	30.5	41.0	68.8
Regenerative Resistor	Built-In Regenerative Resistor	Resistance [Ω ]	-	-	-	40
		Capacity [W]	-	-	-	40
	Minimum Allowable External Resistance [Ω ]	40	40	40	40	40
Overvoltage Category		III				

\* This is the net value at the rated load.

## ◆ 270 VDC

Model SGD7S-		R70A	R90A	1R6A	2R8A	3R8A	5R5A	7R6A	120A
Maximum Applicable Motor Capacity [kW]		0.05	0.1	0.2	0.4	0.5	0.75	1.0	1.5
Continuous Output Current [Arms]		0.66	0.91	1.6	2.8	3.8	5.5	7.6	11.6
Instantaneous Maximum Output Current [Arms]		2.1	3.2	5.9	9.3	11.0	16.9	17.0	28.0
Main Circuit	Power Supply	270 VDC to 324 VDC, -15% to +10%							
	Input Current [Arms]*	0.5	1.0	1.5	3.0	3.8	4.9	6.9	11
Control Power Supply		270 VDC to 324 VDC, -15% to +10%							
Power Supply Capacity [kVA]*		0.2	0.3	0.6	1	1.4	1.6	2.3	3.2
Power Loss*	Main Circuit Power Loss [W]	4.6	6.3	11.7	20.2	16.9	37.9	46.0	53.2
	Control Circuit Power Loss [W]	17	17	17	17	17	17	17	22
	Total Power Loss [W]	21.6	23.3	28.7	37.2	33.9	54.9	63.0	75.2
Overvoltage Category		III							

\* This is the net value at the rated load.

Model SGD7S-		180A	200A	330A	470A	550A	590A	780A
Maximum Applicable Motor Capacity [kW]		2.0	3.0	5.0	6.0	7.5	11.0	15.0
Continuous Output Current [Arms]		18.5	19.6	32.9	46.9	54.7	58.6	78.0
Instantaneous Maximum Output Current [Arms]		42.0	56.0	84.0	110	130	140	170
Main Circuit	Power Supply	270 VDC to 324 VDC, -15% to +10%						
	Input Current [Arms]*	14	20	34	36	48	68	92
Control Power Supply		270 VDC to 324 VDC, -15% to +10%						
Power Supply Capacity [kVA]*		4.0	5.9	7.5	10.7	14.6	21.7	29.6
Power Loss*	Main Circuit Power Loss [W]	95.8	87.6	163.7	203.4	261.2	246.6	346.5
	Control Circuit Power Loss [W]	22	22	27	33	33	48	48
	Total Power Loss [W]	117.8	109.6	190.7	236.4	294.2	294.6	394.5
Overvoltage Category		III						

\* This is the net value at the rated load.

## SERVOPACK Overload Protection Characteristics

The overload detection level is set for hot start conditions with a SERVOPACK surrounding air temperature of 55°C.

An overload alarm (A.710 or A.720) will occur if overload operation that exceeds the overload protection characteristics shown in the following diagram (i.e., operation on the right side of the applicable line) is performed.

The actual overload detection level will be the detection level of the connected SERVOPACK or Servo Motor that has the lower overload protection characteristics.

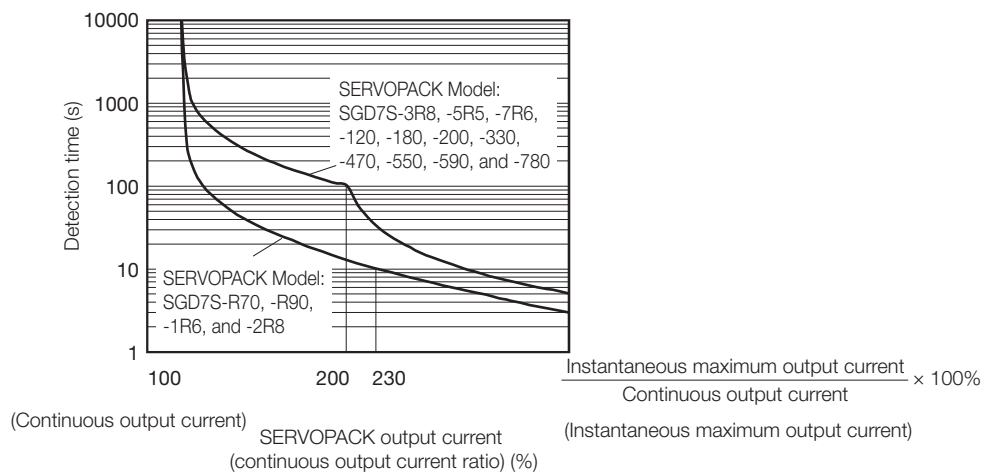

In most cases, that will be the overload protection characteristics of the Servo Motor.



Note: The above overload protection characteristics do not mean that you can perform continuous duty operation with an output of 100% or higher.

For a Yaskawa-specified combination of SERVOPACK and Servo Motor, maintain the effective torque (or effective force) within the continuous duty zone of the torque-motor speed characteristic (or force-motor speed characteristics) of the Servo Motor.

## Specifications

Item		Specification								
Control Method		IGBT-based PWM control, sine wave current drive								
Feedback	With Rotary Servo Motor	Serial encoder: 20 bits or 24 bits (incremental encoder/absolute encoder)								
	With Linear Servo Motor	<ul style="list-style-type: none"> <li>Absolute linear encoder (The signal resolution depends on the absolute linear encoder.)</li> <li>Incremental linear encoder (The signal resolution depends on the incremental linear encoder or Serial Converter Unit.)</li> </ul>								
Environmental Conditions	Surrounding Air Temperature* <sup>1</sup>	-5°C to 55°C With derating, usage is possible between 55°C and 60°C. Refer to the following section for derating specifications.  <i>Derating Specifications</i> (page 287)								
	Storage Temperature	-20°C to 85°C								
	Surrounding Air Humidity	95% relative humidity max. (with no freezing or condensation)								
	Storage Humidity	95% relative humidity max. (with no freezing or condensation)								
	Vibration Resistance	4.9 m/s <sup>2</sup>								
	Shock Resistance	19.6 m/s <sup>2</sup>								
	Degree of Protection	<table border="1"> <thead> <tr> <th>Class</th> <th>SERVOPACK Model: SGD7S-</th> </tr> </thead> <tbody> <tr> <td>IP20</td> <td>R70A, R90A, 1R6A, 2R8A, 3R8A, 5R5A, 7R6A, 120A</td> </tr> <tr> <td>IP10</td> <td>180A, 200A, 330A, 470A, 550A, 590A, 780A</td> </tr> </tbody> </table>	Class	SERVOPACK Model: SGD7S-	IP20	R70A, R90A, 1R6A, 2R8A, 3R8A, 5R5A, 7R6A, 120A	IP10	180A, 200A, 330A, 470A, 550A, 590A, 780A		
	Class	SERVOPACK Model: SGD7S-								
	IP20	R70A, R90A, 1R6A, 2R8A, 3R8A, 5R5A, 7R6A, 120A								
	IP10	180A, 200A, 330A, 470A, 550A, 590A, 780A								
Pollution Degree	2 <ul style="list-style-type: none"> <li>Must be no corrosive or flammable gases.</li> <li>Must be no exposure to water, oil, or chemicals.</li> <li>Must be no dust, salts, or iron dust.</li> </ul>									
Altitude* <sup>1</sup>	1,000 m or less. With derating, usage is possible between 1,000 m and 2,000 m. Refer to the following section for derating specifications.  <i>Derating Specifications</i> (page 287)									
Others	Do not use the SERVOPACK in the following locations: Locations subject to static electricity noise, strong electromagnetic/magnetic fields, or radioactivity									
Applicable Standards		UL 61800-5-1, CSA C22.2 No.274, EN 50178, EN 61800-5-1, EN 55011 group 1 class A, EN 61000-6-2, EN 61000-6-4, EN 61800-3, IEC 61508-1 to 4, IEC 61800-5-2, IEC 62061, ISO 13849-1, and IEC 61326-3-1								
Mounting		<table border="1"> <thead> <tr> <th>Mounting</th> <th>SERVOPACK Model: SGD7S-</th> </tr> </thead> <tbody> <tr> <td>Base-mounted</td> <td>All Models</td> </tr> <tr> <td>Rack-mounted</td> <td>R70A, R90A, 1R6A, 2R8A, 3R8A, 5R5A, 7R6A, 120A, 180A, 200A, 330A</td> </tr> <tr> <td>Duct-ventilated</td> <td>470A, 550A, 590A, 780A</td> </tr> </tbody> </table>	Mounting	SERVOPACK Model: SGD7S-	Base-mounted	All Models	Rack-mounted	R70A, R90A, 1R6A, 2R8A, 3R8A, 5R5A, 7R6A, 120A, 180A, 200A, 330A	Duct-ventilated	470A, 550A, 590A, 780A
Mounting	SERVOPACK Model: SGD7S-									
Base-mounted	All Models									
Rack-mounted	R70A, R90A, 1R6A, 2R8A, 3R8A, 5R5A, 7R6A, 120A, 180A, 200A, 330A									
Duct-ventilated	470A, 550A, 590A, 780A									
Performance	Speed Control Range	1:5000 (At the rated torque, the lower limit of the speed control range must not cause the Servo Motor to stop.)								
	Coefficient of Speed Fluctuation* <sup>2</sup>	±0.01% of rated speed max. (for a load fluctuation of 0% to 100%)								
		0% of rated speed max. (for a voltage fluctuation of ±10%)								
		±0.1% of rated speed max. (for a temperature fluctuation of 25°C ±25°C)								
Torque Control Precision (Repeatability)	±1%									
Soft Start Time Setting	0 s to 10 s (Can be set separately for acceleration and deceleration.)									

Continued on next page.

Continued from previous page.

Item		Specification	
I/O Signals	Encoder Divided Pulse Output	Phase A, phase B, phase C: Line-driver output Number of divided output pulses: Any setting is allowed.	
	Linear Servo Motor Overheat Protection Signal Input	Number of input points: 1 Input voltage range: 0 V to +5 V	
	Sequence Input Signals	Fixed Input	Allowable voltage range: 5 VDC ±5% Number of input points: 1 Absolute Data Request (SEN)
		Input Signals That Can Be Allocated	Allowable voltage range: 24 VDC ±20% Number of input points: 7
			Input method: Sink inputs or source inputs Input Signals: <ul style="list-style-type: none"> <li>• Servo ON (/S-ON)</li> <li>• Proportional Control (/P-CON)</li> <li>• Forward Drive Prohibit (P-OT) and Reverse Drive Prohibit (N-OT)</li> <li>• Alarm Reset (/ALM-RST)</li> <li>• Forward External Torque Limit (/P-CL) and Reverse External Torque Limit (/N-CL)</li> <li>• Motor Direction (/SPD-D)</li> <li>• Internal Set Speed Selection (/SPD-A and /SPD-B)</li> <li>• Control Selection (/C-SEL)</li> <li>• Zero Clamping (/ZCLAMP)</li> <li>• Reference Pulse Inhibit (/INHIBIT)</li> <li>• Polarity Detection (/P-DET)</li> <li>• Gain Selection (/G-SEL)</li> <li>• Reference Pulse Input Multiplication Switch (/PSEL)</li> <li>• Absolute Data Request (SEN)</li> </ul> A signal can be allocated and the positive and negative logic can be changed.
			Fixed Output
	Sequence Output Signals	Output Signals That Can Be Allocated	Allowable voltage range: 5 VDC to 30 VDC Number of output points: 6 (A photocoupler output (isolated) is used for three of the outputs.) (An open-collector output (non-isolated) is used for the other three outputs.)
Output Signals: <ul style="list-style-type: none"> <li>• Positioning Completion (/COIN)</li> <li>• Speed Coincidence Detection (/V-CMP)</li> <li>• Rotation Detection (/TGON)</li> <li>• Servo Ready Output (/S-RDY)</li> <li>• Torque Limit Detection (/CLT)</li> <li>• Speed Limit Detection (/VLT)</li> <li>• Brake (/BK)</li> <li>• Warning Output (/WARN)</li> <li>• Near Output (/NEAR)</li> <li>• Reference Pulse Input Multiplication Switching (/PSELA)</li> <li>• Alarm Code (ALO1, ALO2, and ALO3)</li> </ul> A signal can be allocated and the positive and negative logic can be changed.			
Communications	RS-422A Communications (CN3)	Interfaces	Digital Operator (JUSP-OP05A-1-E) and personal computer (with SigmaWin+)
		1:N Communications	Up to N = 15 stations possible for RS-422A port
		Axis Address Setting	Set with parameters.
	USB Communications (CN7)	Interface	Personal computer (with SigmaWin+)
		Communications Standard	Conforms to USB2.0 standard (12 Mbps).
Displays/Indicators		CHARGE indicator and five-digit seven-segment display	
Panel Operator		Four push switches	



Continued from previous page.

Item		Specification			
Analog Monitor (CN5)		Number of points: 2 Output voltage range: ±10 VDC (effective linearity range: ±8 V) Resolution: 16 bits Accuracy: ±20 mV (Typ) Maximum output current: ±10 mA Settling time (±1%): 1.2 ms (Typ)			
Dynamic Brake (DB)		Activated when a servo alarm or overtravel (OT) occurs, or when the power supply to the main circuit or servo is OFF.			
Regenerative Processing		Built-in (An external resistor must be connected to the SGD7S-470A to -780A.)  <i>Built-In Regenerative Resistor</i> (page 385)			
Overtravel (OT) Prevention		Stopping with dynamic brake, deceleration to a stop, or coasting to a stop for the P-OT (Forward Drive Prohibit) or N-OT (Reverse Drive Prohibit) signal			
Protective Functions		Overcurrent, overvoltage, low voltage, overload, regeneration error, etc.			
Utility Functions		Gain adjustment, alarm history, jogging, origin search, etc.			
Safety Functions	Inputs	/HWBB1 and /HWBB2: Base block signals for Power Modules			
	Output	EDM1: Monitors the status of built-in safety circuit (fixed output).			
	Applicable Standards*3	ISO13849-1 PLe (Category 3) and IEC61508 SIL3			
Option Module		Fully-Closed Modules and Safety Modules Note: You cannot use a Fully-Closed Module and a Safety Module together.			
Controls	Speed Control	Soft Start Time Setting		0 s to 10 s (Can be set separately for acceleration and deceleration.)	
		Input Signal	Reference Voltage	<ul style="list-style-type: none"> <li>Maximum input voltage: ±12 V (forward motor rotation for positive reference).</li> <li>6 VDC at rated speed (default setting). Input gain setting can be changed.</li> </ul>	
			Input Impedance	Approx. 14 kΩ	
			Circuit Time Constant	30 μs	
		Internal Set Speed Control	Rotation Direction Selection	With Proportional Control signal	
			Speed Selection	With Forward/Reverse External Torque Limit signals (speed 1 to 3 selection). Servo Motor stops or another control method is used when both signals are OFF.	
	Position Control	Feedforward Compensation		0% to 100%	
		Output Signal Positioning Completed Width Setting		0 to 1,073,741,824 reference units	
		Input Signals	Reference pulses	Reference Pulse Form	One of the following is selected: Sign + pulse train, CW + CCW pulse trains, and two-phase pulse trains with 90° phase differential
				Input Form	Line driver or open collector
				Maximum Input Frequency	<ul style="list-style-type: none"> <li>Line Driver Sign + pulse train or CW + CCW pulse trains: 4 Mpps Two-phase pulse trains with 90° phase differential: 1 Mpps</li> <li>Open Collector Sign + pulse train or CW + CCW pulse trains: 200 kpps Two-phase pulse trains with 90° phase differential: 200 kpps</li> </ul>
				Input Multiplication Switching	1 to 100 times
		Clear Signal		Position deviation clear Line driver or open collector	

## SERVOPACKs

### Σ-7S Single-axis Analog Voltage/Pulse Train Reference SERVOPACKs

Continued from previous page.

Item			Specification
Controls	Torque Control	Input Signal	Reference Voltage
			Input Impedance
			Circuit Time Constant
			<ul style="list-style-type: none"><li>• Maximum input voltage: ±12 V (forward torque output for positive reference).</li><li>• 3 VDC at rated torque (default setting). Input gain setting can be changed.</li></ul>
			Approx. 14 kΩ
			16 μs

\*1. If you combine a Σ-7-Series SERVOPACK with a Σ-V-Series Option Module, the following Σ-V-Series SERVOPACKs specifications must be used: a surrounding air temperature of 0°C to 55°C and an altitude of 1,000 m max. Also, the applicable range cannot be increased by derating.

\*2. The coefficient of speed fluctuation for load fluctuation is defined as follows:

$$\text{Coefficient of speed fluctuation} = \frac{\text{No-load motor speed} - \text{Total-load motor speed}}{\text{Rated motor speed}} \times 100\%$$

\*3. Always perform risk assessment for the system and confirm that the safety requirements are met.

## Derating Specifications

If you use the SERVOPACK at a surrounding air temperature of 55°C to 60°C or at an altitude of 1,000 m to 2,000 m, you must apply the derating rates given in the following graphs.

### ◆ SGD7S-R70A, -R90A, -1R6A, and -2R8A

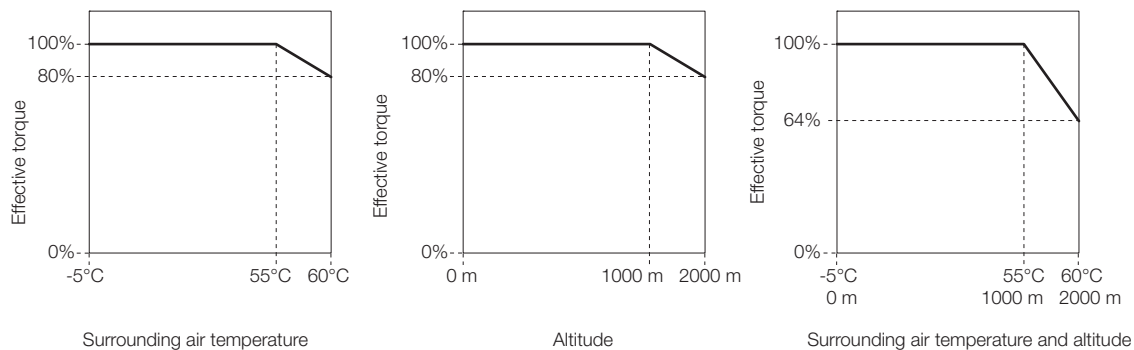

### ◆ SGD7S-3R8A, -5R5A, -7R6A, -120A, -180A, -200A, -330A, -470A, -550A, -590A, and -780A

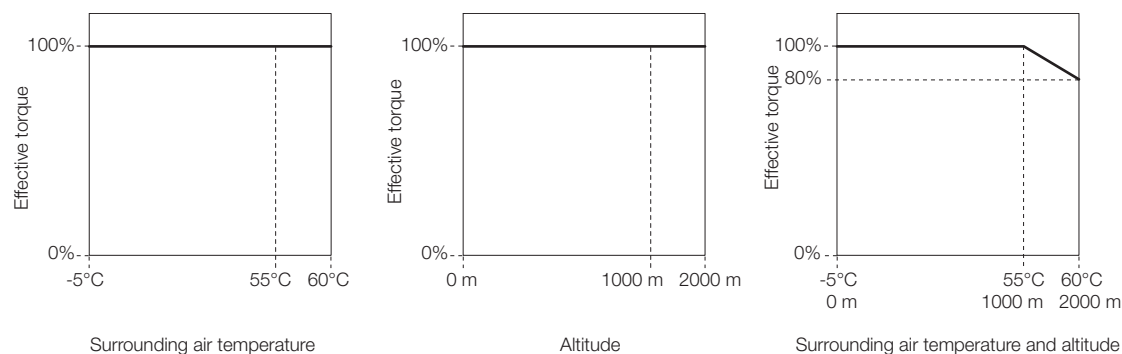

---

**Model Designations**

---

SGD7S - R70 A 30 A

Σ-7 Series  
Σ-7S SERVOPACKs
1st+2nd+3rd  
digits
4th  
digit
5th+6th  
digits
7th  
digit

**1st+2nd+3rd digits** Maximum Applicable Motor Capacity

Voltage	Code	Specification
Three-phase, 200 VAC	R70* <sup>1</sup>	0.05 kW
	R90* <sup>1</sup>	0.1 kW
	1R6* <sup>1</sup>	0.2 kW
	2R8* <sup>1</sup>	0.4 kW
	3R8	0.5 kW
	5R5* <sup>1</sup>	0.75 kW
	7R6	1.0 kW
	120* <sup>3</sup>	1.5 kW
	180	2.0 kW
	200	3.0 kW
	330	5.0 kW
	470	6.0 kW
550	7.5 kW	
590	11 kW	
780	15 kW	
Single-phase, 100 VAC	R70	0.05 kW
	R90	0.1 kW
	2R1	0.2 kW
	2R8	0.4 kW

**4th digit** Voltage

Code	Specification
A	200 VAC
F	100 VAC

**5th+6th digits** Interface\*<sup>2</sup>

Code	Specification
30	MECHATROLINK-III communications reference

**7th digit** Design Revision Order

A: Global design revision

- \*1. You can use these models with either a single-phase or three-phase power supply input.
- \*2. The same SERVOPACKs are used for both Rotary Servo Motors and Linear Servo Motors.
- \*3. A model with a single-phase, 200-VAC power supply input is available as a hardware option (model: SGD7S-120A30A008).

## Ratings and Specifications

### Ratings

#### ◆ Single-phase, 100 VAC

Model SGD7S-		R70F	R90F	2R1F	2R8F
Maximum Applicable Motor Capacity [kW]		0.05	0.1	0.2	0.4
Continuous Output Current [Arms]		0.66	0.91	2.1	2.8
Instantaneous Maximum Output Current [Arms]		2.1	3.2	6.5	9.3
Main Circuit	Power Supply	100 VAC to 120 VAC, -15% to +10%, 50/60 Hz			
	Input Current [Arms]*	1.5	2.5	5	10
Control Power Supply		100 VAC to 120 VAC, -15% to +10%, 50/60 Hz			
Power Supply Capacity [kVA]*		0.2	0.3	0.6	1.4
Power Loss*	Main Circuit Power Loss [W]	5.3	7.8	14.2	26.2
	Control Circuit Power Loss [W]	12	12	12	12
	Total Power Loss [W]	17.3	19.8	26.2	38.2
Regenerative Resistor	Minimum Allowable External Resistance [ $\Omega$ ]	40	40	40	40
Overvoltage Category		III			

\* This is the net value at the rated load.

#### ◆ Three-phase, 200 VAC

Model SGD7S-		R70A	R90A	1R6A	2R8A	3R8A	5R5A	7R6A	120A	180A	200A	330A	
Maximum Applicable Motor Capacity [kW]		0.05	0.1	0.2	0.4	0.5	0.75	1.0	1.5	2.0	3.0	5.0	
Continuous Output Current [Arms]		0.66	0.91	1.6	2.8	3.8	5.5	7.6	11.6	18.5	19.6	32.9	
Instantaneous Maximum Output Current [Arms]		2.1	3.2	5.9	9.3	11	16.9	17	28	42	56	84.0	
Main Circuit	Power Supply	200 VAC to 240 VAC, -15% to +10%, 50 Hz/60 Hz											
	Input Current [Arms]*	0.4	0.8	1.3	2.5	3.0	4.1	5.7	7.3	10	15	25	
Control Power Supply		200 VAC to 240 VAC, -15% to +10%, 50 Hz/60 Hz											
Power Supply Capacity [kVA]*		0.2	0.3	0.5	1.0	1.3	1.6	2.3	3.2	4.0	5.9	7.5	
Power Loss*	Main Circuit Power Loss [W]	5.1	7.3	13.5	24.0	20.1	43.8	53.6	65.8	111.9	113.8	263.7	
	Control Circuit Power Loss [W]	17	17	17	17	17	17	17	22	22	22	27	
	Built-in Regenerative Resistor Power Loss [W]	-	-	-	-	8	8	8	10	16	16	36.0	
	Total Power Loss [W]	22.1	24.3	30.5	41.0	45.1	68.8	78.6	97.8	149.9	151.8	326.7	
Regenerative Resistor	Built-In Regenerative Resistor	Resistance [ $\Omega$ ]	-	-	-	-	40	40	40	20	12	12	8
		Capacity [W]	-	-	-	-	40	40	40	60	60	60	180
	Minimum Allowable External Resistance [ $\Omega$ ]	40	40	40	40	40	40	40	40	20	12	12	8
Overvoltage Category		III											

\* This is the net value at the rated load.

## SERVOPACKs

### Σ-7S Single-axis MECHATROLINK-III Communications Reference SERVOPACKs

Model SGD7S-		470A	550A	590A	780A
Maximum Applicable Motor Capacity [kW]		6.0	7.5	11	15
Continuous Output Current [Arms]		46.9	54.7	58.6	78.0
Instantaneous Maximum Output Current [Arms]		110	130	140	170
Main Circuit	Power Supply	200 VAC to 240 VAC, -15%% to +10%, 50 Hz/60 Hz			
	Input Current [Arms] <sup>*1</sup>	29	37	54	73
Control Power Supply		200 VAC to 240 VAC, -15%% to +10%, 50 Hz/60 Hz			
Power Supply Capacity [kVA] <sup>*1</sup>		10.7	14.6	21.7	29.6
Power Loss <sup>*1</sup>	Main Circuit Power Loss [W]	279.4	357.8	431.7	599.0
	Control Circuit Power Loss [W]	33	33	48	48
	External Regenerative Resistor Unit Power Loss [W]	180 <sup>*2</sup>	180 <sup>*3</sup>	350 <sup>*3</sup>	350 <sup>*3</sup>
	Total Power Loss [W]	312.4	390.8	479.7	647.0
External Regenerative Resistor Unit	External Regenerative Resistor Unit	Resistance [Ω]	6.25 <sup>*2</sup>	3.13 <sup>*3</sup>	3.13 <sup>*3</sup>
		Capacity [W]	880 <sup>*2</sup>	1760 <sup>*3</sup>	1760 <sup>*3</sup>
	Minimum Allowable External Resistance [Ω]	5.8	2.9	2.9	2.9
Overvoltage Category		III			

\*1. This is the net value at the rated load.

\*2. This value is for the optional JUSP-RA04-E Regenerative Resistor Unit.

\*3. This value is for the optional JUSP-RA05-E Regenerative Resistor Unit.

### ◆ Single-phase, 200 VAC

Model SGD7S-		R70A	R90A	1R6A	2R8A	5R5A
Maximum Applicable Motor Capacity [kW]		0.05	0.1	0.2	0.4	0.75
Continuous Output Current [Arms]		0.66	0.91	1.6	2.8	5.5
Instantaneous Maximum Output Current [Arms]		2.1	3.2	5.9	9.3	16.9
Main Circuit	Power Supply	200 VAC to 240 VAC, -15% to +10%, 50 Hz/60 Hz				
	Input Current [Arms]*	0.8	1.6	2.4	5.0	8.7
Control Power Supply		200 VAC to 240 VAC, -15% to +10%, 50 Hz/60 Hz				
Power Supply Capacity [kVA]*		0.2	0.3	0.6	1.2	1.9
Power Loss*	Main Circuit Power Loss [W]	5.1	7.3	13.5	24.0	43.8
	Control Circuit Power Loss [W]	17	17	17	17	17
	Built-in Regenerative Resistor Power Loss [W]	–	–	–	–	8
	Total Power Loss [W]	22.1	24.3	30.5	41.0	68.8
Regenerative Resistor	Built-In Regenerative Resistor	Resistance [Ω]	–	–	–	40
		Capacity [W]	–	–	–	40
	Minimum Allowable External Resistance [Ω]	40	40	40	40	40
Overvoltage Category		III				

\* This is the net value at the rated load.

## ◆ 270 VDC

Model SGD7S-		R70A	R90A	1R6A	2R8A	3R8A	5R5A	7R6A	120A
Maximum Applicable Motor Capacity [kW]		0.05	0.1	0.2	0.4	0.5	0.75	1.0	1.5
Continuous Output Current [Arms]		0.66	0.91	1.6	2.8	3.8	5.5	7.6	11.6
Instantaneous Maximum Output Current [Arms]		2.1	3.2	5.9	9.3	11.0	16.9	17.0	28.0
Main Circuit	Power Supply	270 VDC to 324 VDC, -15% to +10%							
	Input Current [Arms]*	0.5	1.0	1.5	3.0	3.8	4.9	6.9	11
Control Power Supply		270 VDC to 324 VDC, -15% to +10%							
Power Supply Capacity [kVA]*		0.2	0.3	0.6	1	1.4	1.6	2.3	3.2
Power Loss*	Main Circuit Power Loss [W]	4.6	6.3	11.7	20.2	16.9	37.9	46.0	53.2
	Control Circuit Power Loss [W]	17	17	17	17	17	17	17	22
	Total Power Loss [W]	21.6	23.3	28.7	37.2	33.9	54.9	63.0	75.2
Overvoltage Category		III							

\* This is the net value at the rated load.

Model SGD7S-		180A	200A	330A	470A	550A	590A	780A
Maximum Applicable Motor Capacity [kW]		2.0	3.0	5.0	6.0	7.5	11.0	15.0
Continuous Output Current [Arms]		18.5	19.6	32.9	46.9	54.7	58.6	78.0
Instantaneous Maximum Output Current [Arms]		42.0	56.0	84.0	110	130	140	170
Main Circuit	Power Supply	270 VDC to 324 VDC, -15% to +10%						
	Input Current [Arms]*	14	20	34	36	48	68	92
Control Power Supply		270 VDC to 324 VDC, -15% to +10%						
Power Supply Capacity [kVA]*		4.0	5.9	7.5	10.7	14.6	21.7	29.6
Power Loss*	Main Circuit Power Loss [W]	95.8	87.6	163.7	203.4	261.2	246.6	346.5
	Control Circuit Power Loss [W]	22	22	27	33	33	48	48
	Total Power Loss [W]	117.8	109.6	190.7	236.4	294.2	294.6	394.5
Overvoltage Category		III						

\* This is the net value at the rated load.

## SERVOPACK Overload Protection Characteristics

The overload detection level is set for hot start conditions with a SERVOPACK surrounding air temperature of 55°C.

An overload alarm (A.710 or A.720) will occur if overload operation that exceeds the overload protection characteristics shown in the following diagram (i.e., operation on the right side of the applicable line) is performed.

The actual overload detection level will be the detection level of the connected SERVOPACK or Servo Motor that has the lower overload protection characteristics.

In most cases, that will be the overload protection characteristics of the Servo Motor.

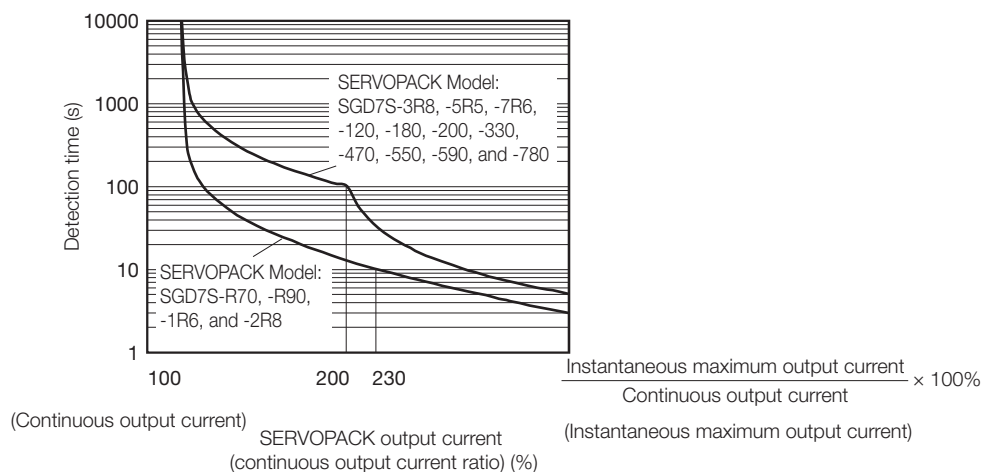



Note: The above overload protection characteristics do not mean that you can perform continuous duty operation with an output of 100% or higher.

For a Yaskawa-specified combination of SERVOPACK and Servo Motor, maintain the effective torque (or effective force) within the continuous duty zone of the torque-motor speed characteristic (or force-motor speed characteristics) of the Servo Motor.



## Specifications

Item		Specification								
Drive Method		IGBT-based PWM control, sine wave current drive								
Feedback	With Rotary Servo Motor	Serial encoder: 20 bits or 24 bits (incremental encoder/absolute encoder)								
	With Linear Servo Motor	<ul style="list-style-type: none"> <li>Absolute linear encoder (The signal resolution depends on the absolute linear encoder.)</li> <li>Incremental linear encoder (The signal resolution depends on the incremental linear encoder or Serial Converter Unit.)</li> </ul>								
Environmental Conditions	Surrounding Air Temperature <sup>*1</sup>	-5°C to 55°C With derating, usage is possible between 55°C and 60°C. Refer to the following section for derating specifications.  <b>Derating Specifications (page 296)</b>								
	Storage Temperature	-20°C to 85°C								
	Surrounding Air Humidity	95% relative humidity max. (with no freezing or condensation)								
	Storage Humidity	95% relative humidity max. (with no freezing or condensation)								
	Vibration Resistance	4.9 m/s <sup>2</sup>								
	Shock Resistance	19.6 m/s <sup>2</sup>								
	Degree of Protection	<table border="1"> <thead> <tr> <th>Class</th> <th>SERVOPACK Model: SGD7S-</th> </tr> </thead> <tbody> <tr> <td>IP20</td> <td>R70A, R90A, 1R6A, 2R8A, 3R8A, 5R5A, 7R6A, 120A</td> </tr> <tr> <td>IP10</td> <td>180A, 200A, 330A, 470A, 550A, 590A, 780A</td> </tr> </tbody> </table>	Class	SERVOPACK Model: SGD7S-	IP20	R70A, R90A, 1R6A, 2R8A, 3R8A, 5R5A, 7R6A, 120A	IP10	180A, 200A, 330A, 470A, 550A, 590A, 780A		
	Class	SERVOPACK Model: SGD7S-								
	IP20	R70A, R90A, 1R6A, 2R8A, 3R8A, 5R5A, 7R6A, 120A								
	IP10	180A, 200A, 330A, 470A, 550A, 590A, 780A								
Pollution Degree	2 <ul style="list-style-type: none"> <li>Must be no corrosive or flammable gases.</li> <li>Must be no exposure to water, oil, or chemicals.</li> <li>Must be no dust, salts, or iron dust.</li> </ul>									
Altitude <sup>*1</sup>	1,000 m or less. With derating, usage is possible between 1,000 m and 2,000 m. Refer to the following section for derating specifications.  <b>Derating Specifications (page 296)</b>									
Others	Do not use the SERVOPACK in the following locations: Locations subject to static electricity noise, strong electromagnetic/magnetic fields, or radioactivity									
Applicable Standards		UL 61800-5-1, CSA C22.2 No.274, EN 50178, EN 61800-5-1, EN 55011 group 1 class A, EN 61000-6-2, EN 61000-6-4, EN 61800-3, IEC 61508-1 to 4, IEC 61800-5-2, IEC 62061, ISO 13849-1, and IEC 61326-3-1								
Mounting		<table border="1"> <thead> <tr> <th>Mounting</th> <th>SERVOPACK Model: SGD7S-</th> </tr> </thead> <tbody> <tr> <td>Base-mounted</td> <td>All Models</td> </tr> <tr> <td>Rack-mounted</td> <td>R70A, R90A, 1R6A, 2R8A, 3R8A, 5R5A, 7R6A, 120A, 180A, 200A, 330A</td> </tr> <tr> <td>Duct-ventilated</td> <td>470A, 550A, 590A, 780A</td> </tr> </tbody> </table>	Mounting	SERVOPACK Model: SGD7S-	Base-mounted	All Models	Rack-mounted	R70A, R90A, 1R6A, 2R8A, 3R8A, 5R5A, 7R6A, 120A, 180A, 200A, 330A	Duct-ventilated	470A, 550A, 590A, 780A
Mounting	SERVOPACK Model: SGD7S-									
Base-mounted	All Models									
Rack-mounted	R70A, R90A, 1R6A, 2R8A, 3R8A, 5R5A, 7R6A, 120A, 180A, 200A, 330A									
Duct-ventilated	470A, 550A, 590A, 780A									
Performance	Speed Control Range	1:5000 (At the rated torque, the lower limit of the speed control range must not cause the Servo Motor to stop.)								
	Coefficient of Speed Fluctuation <sup>*2</sup>	±0.01% of rated speed max. (for a load fluctuation of 0% to 100%)								
		0% of rated speed max. (for a voltage fluctuation of ±10%)								
		±0.1% of rated speed max. (for a temperature fluctuation of 25°C ±25°C)								
Torque Control Precision (Repeatability)	±1%									
Soft Start Time Setting	0 s to 10 s (Can be set separately for acceleration and deceleration.)									

Continued from previous page.

Item		Specification	
I/O Signals	Encoder Divided Pulse Output	Phase A, phase B, phase C: Line-driver output Number of divided output pulses: Any setting is allowed.	
	Linear Servo Motor Overheat Protection Signal Input	Number of input points: 1 Input voltage range: 0 V to +5 V	
	Sequence Input Signals	Input Signals That Can Be Allocated	Allowable voltage range: 24 VDC $\pm$ 20% Number of input points: 7
			Input method: Sink inputs or source inputs Input Signals: <ul style="list-style-type: none"> <li>• Origin Return Deceleration Switch (/DEC)</li> <li>• External Latch 1 to 3 (/EXT 1 to 3)</li> <li>• Forward Drive Prohibit (P-OT) and Reverse Drive Prohibit (N-OT)</li> <li>• Forward External Torque Limit (/P-CL) and Reverse External Torque Limit (/N-CL)</li> <li>• Polarity Detection (/P-DET)</li> </ul> A signal can be allocated and the positive and negative logic can be changed.
	Sequence Output Signals	Fixed Output	Allowable voltage range: 5 VDC to 30 VDC Number of output points: 1 Output signal: Servo Alarm (ALM)
		Output Signals That Can Be Allocated	Allowable voltage range: 5 VDC to 30 VDC Number of output points: 3 (A photocoupler output (isolated) is used.) Output Signals: <ul style="list-style-type: none"> <li>• Positioning Completion (/COIN)</li> <li>• Speed Coincidence Detection (/V-CMP)</li> <li>• Rotation Detection (/TGON)</li> <li>• Servo Ready Output (/S-RDY)</li> <li>• Torque Limit Detection (/CLT)</li> <li>• Speed Limit Detection (/VLT)</li> <li>• Brake (/BK)</li> <li>• Warning Output (/WARN)</li> <li>• Near Output (/NEAR)</li> </ul> A signal can be allocated and the positive and negative logic can be changed.
Communications	RS-422A Communications (CN3)	Inter- faces	Digital Operator (JUSP-OP05A-1-E) and personal computer (with SigmaWin+)
		1:N Com- muni- cations	Up to N = 15 stations possible for RS-422A port
		Axis Address Setting	Set with parameters.
	USB Com- muni- cations (CN7)	Interface	Personal computer (with SigmaWin+)
Commu- nications Standard		Conforms to USB2.0 standard (12 Mbps).	
Displays/Indicators		CHARGE, PWR, COM, L1, and L2 indicators, and one-digit seven-segment display	
MECHA- TROLINK-III Communi- cations	Communications Proto- col	MECHATROLINK-III	
	Station Address Settings	03 to EF hex (maximum number of slaves: 62) The rotary switches (S1 and S2) are used to set the station address.	
	Baud Rate	100 Mbps	
	Transmission Cycle	125 $\mu$ s, 250 $\mu$ s, 500 $\mu$ s, 750 $\mu$ s, 1.0 ms to 4.0 ms (multiples of 0.5 ms)	
	Number of Transmis- sion Bytes	32 or 48 bytes/station A DIP switch (S3) is used to select the number of transmission bytes.	

Continued from previous page.

Item		Specification
Reference Method	Performance	Position, speed, or torque control with MECHATROLINK-III communications
	Reference Input	MECHATROLINK-III commands (sequence, motion, data setting, data access, monitoring, adjustment, etc.)
	Profile	MECHATROLINK-III standard servo profile
MECHATROLINK-III Communications Setting Switches		Rotary switch (S1 and S2) positions: 16
		Number of DIP switch (S3) pins: 4
Analog Monitor (CN5)		Number of points: 2 Output voltage range: ±10 VDC (effective linearity range: ±8 V) Resolution: 16 bits Accuracy: ±20 mV (Typ) Maximum output current: ±10 mA Settling time (±1%): 1.2 ms (Typ)
Dynamic Brake (DB)		Activated when a servo alarm or overtravel (OT) occurs, or when the power supply to the main circuit or servo is OFF.
Regenerative Processing		Built-in (An external resistor must be connected to the SGD7S-470A to -780A.)  <b>Built-In Regenerative Resistor (page 385)</b>
Overtravel (OT) Prevention		Stopping with dynamic brake, deceleration to a stop, or coasting to a stop for the P-OT (Forward Drive Prohibit) or N-OT (Reverse Drive Prohibit) signal
Protective Functions		Overcurrent, overvoltage, low voltage, overload, regeneration error, etc.
Utility Functions		Gain adjustment, alarm history, jogging, origin search, etc.
Safety Functions	Inputs	/HWBB1 and /HWBB2: Base block signals for Power Modules
	Output	EDM1: Monitors the status of built-in safety circuit (fixed output).
	Applicable Standards*3	ISO13849-1 PLe (Category 3), IEC61508 SIL3
Option Module		Fully-Closed Modules and Safety Modules Note: You cannot use a Fully-Closed Module and a Safety Module together.

\*1. If you combine a Σ-7-Series SERVOPACK with a Σ-V-Series Option Module, the following Σ-V-Series SERVOPACKs specifications must be used: a surrounding air temperature of 0°C to 55°C and an altitude of 1,000 m max. Also, the applicable range cannot be increased by derating.

\*2. The coefficient of speed fluctuation for load fluctuation is defined as follows:

$$\text{Coefficient of speed fluctuation} = \frac{\text{No-load motor speed} - \text{Total-load motor speed}}{\text{Rated motor speed}} \times 100\%$$

\*3. Always perform risk assessment for the system and confirm that the safety requirements are met.

## Derating Specifications

If you use the SERVOPACK at a surrounding air temperature of 55°C to 60°C or at an altitude of 1,000 m to 2,000 m, you must apply the derating rates given in the following graphs.

### ◆ SGD7S-R70A, -R90A, -1R6A, and -2R8A

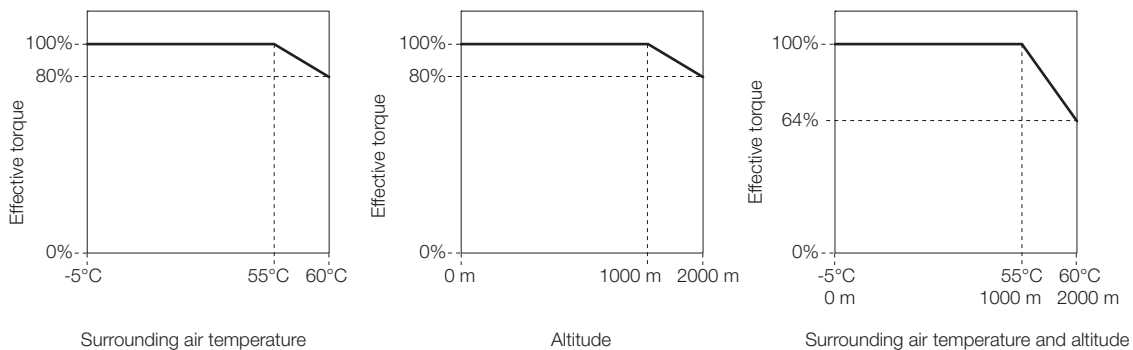

### ◆ SGD7S-3R8A, -5R5A, -7R6A, -120A, -180A, -200A, -330A, -470A, -550A, -590A, and -780A

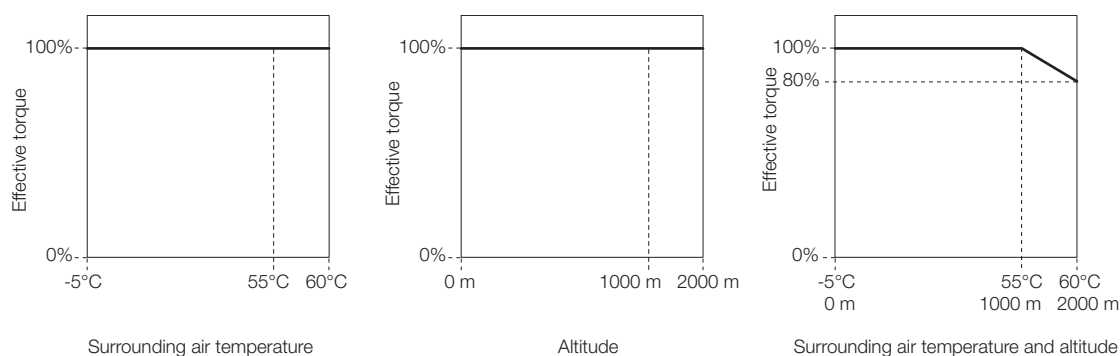



## Model Designations

SGD7S

Σ-7 Series  
Σ-7S SERVOPACKs

R70

1st+2nd+3rd  
digits

A

4th  
digit

A0

5th+6th  
digits

A

7th  
digit

1st+2nd+3rd digits

Maximum Applicable  
Motor Capacity

Voltage	Code	Specification
Three-phase, 200 VAC	R70 <sup>*1</sup>	0.05 kW
	R90 <sup>*1</sup>	0.1 kW
	1R6 <sup>*1</sup>	0.2 kW
	2R8 <sup>*1</sup>	0.4 kW
	3R8	0.5 kW
	5R5 <sup>*1</sup>	0.75 kW
	7R6	1.0 kW
	120 <sup>*3</sup>	1.5 kW
	180	2.0 kW
	200	3.0 kW
	330	5.0 kW
	470	6.0 kW
550	7.5 kW	
590	11 kW	
780	15 kW	
Single-phase, 100 VAC	R70	0.05 kW
	R90	0.1 kW
	2R1	0.2 kW
	2R8	0.4 kW

4th digit

Voltage

Code	Specification
A	200 VAC
F	100 VAC

5th+6th digits

Interface<sup>\*2</sup>

Code	Specification
A0	EtherCAT communications reference

7th digit

Design Revision Order

A: Global design revision

\*1. You can use these models with either a single-phase or three-phase power supply input.

\*2. The same SERVOPACKs are used for both Rotary Servo Motors and Linear Servo Motors.

\*3. A model with a single-phase, 200-VAC power supply input is available as a hardware option (model: SGD7S-120AA0A008).

## Ratings and Specifications

### Ratings

#### ◆ Single-phase, 100 VAC

Model SGD7S-		R70F	R90F	2R1F	2R8F
Maximum Applicable Motor Capacity [kW]		0.05	0.1	0.2	0.4
Continuous Output Current [Arms]		0.66	0.91	2.1	2.8
Instantaneous Maximum Output Current [Arms]		2.1	3.2	6.5	9.3
Main Circuit	Power Supply	100 VAC to 120 VAC, -15% to +10%, 50/60 Hz			
	Input Current [Arms]*	1.5	2.5	5	10
Control Power Supply		100 VAC to 120 VAC, -15% to +10%, 50/60 Hz			
Power Supply Capacity [kVA]*		0.2	0.3	0.6	1.4
Power Loss*	Main Circuit Power Loss [W]	5.3	7.8	14.2	26.2
	Control Circuit Power Loss [W]	12	12	12	12
	Total Power Loss [W]	17.3	19.8	26.2	38.2
Regenerative Resistor	Minimum Allowable External Resistance [ $\Omega$ ]	40	40	40	40
Overvoltage Category		III			

\* This is the net value at the rated load.

#### ◆ Three-phase, 200 VAC

Model SGD7S-		R70 A	R90 A	1R6 A	2R8 A	3R8 A	5R5 A	7R6 A	120A	180A	200A	330A	
Maximum Applicable Motor Capacity [kW]		0.05	0.1	0.2	0.4	0.5	0.75	1.0	1.5	2.0	3.0	5.0	
Continuous Output Current [Arms]		0.66	0.91	1.6	2.8	3.8	5.5	7.6	11.6	18.5	19.6	32.9	
Instantaneous Maximum Output Current [Arms]		2.1	3.2	5.9	9.3	11	16.9	17	28	42	56	84.0	
Main Circuit	Power Supply	200 VAC to 240 VAC, -15% to +10%, 50 Hz/60 Hz											
	Input Current [Arms]*	0.4	0.8	1.3	2.5	3.0	4.1	5.7	7.3	10	15	25	
Control Power Supply		200 VAC to 240 VAC, -15% to +10%, 50 Hz/60 Hz											
Power Supply Capacity [kVA]*		0.2	0.3	0.5	1.0	1.3	1.6	2.3	3.2	4.0	5.9	7.5	
Power Loss*	Main Circuit Power Loss [W]	5.1	7.3	13.5	24.0	20.1	43.8	53.6	65.8	111.9	113.8	263.7	
	Control Circuit Power Loss [W]	17	17	17	17	17	17	17	22	22	22	27	
	Built-in Regenerative Resistor Power Loss [W]	–	–	–	–	8	8	8	10	16	16	36.0	
	Total Power Loss [W]	22.1	24.3	30.5	41.0	45.1	68.8	78.6	97.8	149.9	151.8	326.7	
Regenerative Resistor	Built-In Regenerative Resistor	Resis- tance [ $\Omega$ ]	–	–	–	–	40	40	40	20	12	12	8
		Capacity [W]	–	–	–	–	40	40	40	60	60	60	180
	Minimum Allowable External Resistance [ $\Omega$ ]	40	40	40	40	40	40	40	40	20	12	12	8
Overvoltage Category		III											

\* This is the net value at the rated load.

## SERVOPACKs

### Σ-7S Single-axis EtherCAT Communications Reference SERVOPACKs

Model SGD7S-		470A	550A	590A	780A
Maximum Applicable Motor Capacity [kW]		6.0	7.5	11	15
Continuous Output Current [Arms]		46.9	54.7	58.6	78.0
Instantaneous Maximum Output Current [Arms]		110	130	140	170
Main Circuit	Power Supply	200 VAC to 240 VAC, -15% to +10%, 50 Hz/60 Hz			
	Input Current [Arms] <sup>*1</sup>	29	37	54	73
Control Power Supply		200 VAC to 240 VAC, -15% to +10%, 50 Hz/60 Hz			
Power Supply Capacity [kVA] <sup>*1</sup>		10.7	14.6	21.7	29.6
Power Loss] <sup>*1</sup>	Main Circuit Power Loss [W]	279.4	357.8	431.7	599.0
	Control Circuit Power Loss [W]	33	33	48	48
	External Regenerative Resistor Unit Power Loss [W]	180 <sup>*2</sup>	180 <sup>*3</sup>	350 <sup>*3</sup>	350 <sup>*3</sup>
	Total Power Loss [W]	312.4	390.8	479.7	647.0
External Regenerative Resistor Unit	External Regenerative Resistor Unit	Resistance [Ω]	6.25 <sup>*2</sup>	3.13 <sup>*3</sup>	3.13 <sup>*3</sup>
		Capacity [W]	880 <sup>*2</sup>	1760 <sup>*3</sup>	1760 <sup>*3</sup>
	Minimum Allowable External Resistance [Ω]	5.8	2.9	2.9	2.9
Overvoltage Category		III			

\*1. This is the net value at the rated load.

\*2. This value is for the optional JUSP-RA04-E Regenerative Resistor Unit.

\*3. This value is for the optional JUSP-RA05-E Regenerative Resistor Unit.

### ◆ Single-phase, 200 VAC

Model SGD7S-		R70A	R90A	1R6A	2R8A	5R5A
Maximum Applicable Motor Capacity [kW]		0.05	0.1	0.2	0.4	0.75
Continuous Output Current [Arms]		0.66	0.91	1.6	2.8	5.5
Instantaneous Maximum Output Current [Arms]		2.1	3.2	5.9	9.3	16.9
Main Circuit	Power Supply	200 VAC to 240 VAC, -15% to +10%, 50 Hz/60 Hz				
	Input Current [Arms]*	0.8	1.6	2.4	5.0	8.7
Control Power Supply		200 VAC to 240 VAC, -15% to +10%, 50 Hz/60 Hz				
Power Supply Capacity [kVA]*		0.2	0.3	0.6	1.2	1.9
Power Loss*	Main Circuit Power Loss [W]	5.1	7.3	13.5	24.0	43.8
	Control Circuit Power Loss [W]	17	17	17	17	17
	Built-in Regenerative Resistor Power Loss [W]	–	–	–	–	8
	Total Power Loss [W]	22.1	24.3	30.5	41.0	68.8
Regenerative Resistor	Built-In Regenerative Resistor	Resistance [Ω]	–	–	–	40
		Capacity [W]	–	–	–	40
	Minimum Allowable External Resistance [Ω]	40	40	40	40	40
Overvoltage Category		III				

\* This is the net value at the rated load.



## ◆ 270 VDC

Model SGD7S-		R70A	R90A	1R6A	2R8A	3R8A	5R5A	7R6A	120A
Maximum Applicable Motor Capacity [kW]		0.05	0.1	0.2	0.4	0.5	0.75	1.0	1.5
Continuous Output Current [Arms]		0.66	0.91	1.6	2.8	3.8	5.5	7.6	11.6
Instantaneous Maximum Output Current [Arms]		2.1	3.2	5.9	9.3	11.0	16.9	17.0	28.0
Main Circuit	Power Supply	270 VDC to 324 VDC, -15% to +10%							
	Input Current [Arms]*	0.5	1.0	1.5	3.0	3.8	4.9	6.9	11
Control Power Supply		270 VDC to 324 VDC, -15% to +10%							
Power Supply Capacity [kVA]*		0.2	0.3	0.6	1	1.4	1.6	2.3	3.2
Power Loss*	Main Circuit Power Loss [W]	4.6	6.3	11.7	20.2	16.9	37.9	46.0	53.2
	Control Circuit Power Loss [W]	17	17	17	17	17	17	17	22
	Total Power Loss [W]	21.6	23.3	28.7	37.2	33.9	54.9	63.0	75.2
Overvoltage Category		III							

\* This is the net value at the rated load.

Model SGD7S-		180A	200A	330A	470A	550A	590A	780A
Maximum Applicable Motor Capacity [kW]		2.0	3.0	5.0	6.0	7.5	11.0	15.0
Continuous Output Current [Arms]		18.5	19.6	32.9	46.9	54.7	58.6	78.0
Instantaneous Maximum Output Current [Arms]		42.0	56.0	84.0	110	130	140	170
Main Circuit	Power Supply	270 VDC to 324 VDC, -15% to +10%						
	Input Current [Arms]*	14	20	34	36	48	68	92
Control Power Supply		270 VDC to 324 VDC, -15% to +10%						
Power Supply Capacity [kVA]*		4.0	5.9	7.5	10.7	14.6	21.7	29.6
Power Loss*	Main Circuit Power Loss [W]	95.8	87.6	163.7	203.4	261.2	246.6	346.5
	Control Circuit Power Loss [W]	22	22	27	33	33	48	48
	Total Power Loss [W]	117.8	109.6	190.7	236.4	294.2	294.6	394.5
Overvoltage Category		III						

\* This is the net value at the rated load.

## SERVOPACK Overload Protection Characteristics

The overload detection level is set for hot start conditions with a SERVOPACK surrounding air temperature of 55°C.

An overload alarm (A.710 or A.720) will occur if overload operation that exceeds the overload protection characteristics shown in the following diagram (i.e., operation on the right side of the applicable line) is performed.

The actual overload detection level will be the detection level of the connected SERVOPACK or Servo Motor that has the lower overload protection characteristics.

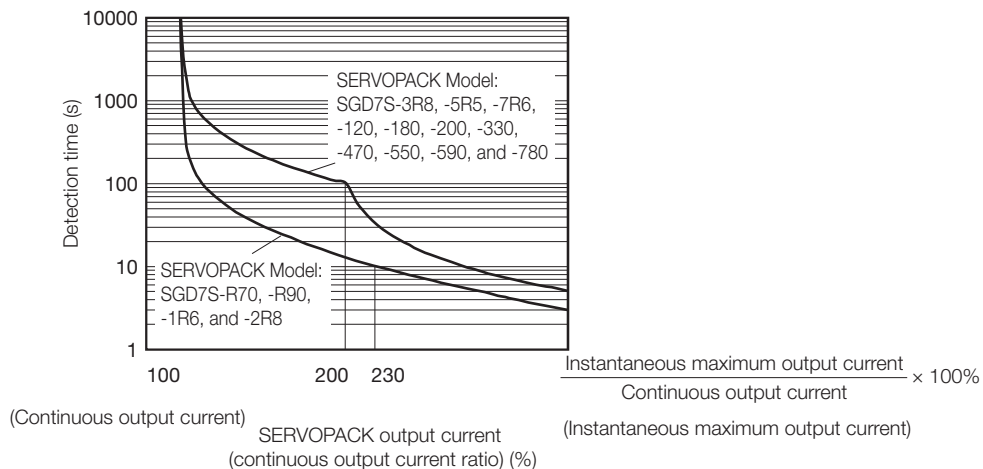

In most cases, that will be the overload protection characteristics of the Servo Motor.



Note: The above overload protection characteristics do not mean that you can perform continuous duty operation with an output of 100% or higher.

For a Yaskawa-specified combination of SERVOPACK and Servo Motor, maintain the effective torque (or effective force) within the continuous duty zone of the torque-motor speed characteristic (or force-motor speed characteristics) of the Servo Motor.

## Specifications

Item		Specification								
Control Method		IGBT-based PWM control, sine wave current drive								
Feedback	With Rotary Servo Motor	Serial encoder: 20 bits or 24 bits (incremental encoder/absolute encoder)								
	With Linear Servo Motor	<ul style="list-style-type: none"> <li>Absolute linear encoder (The signal resolution depends on the absolute linear encoder.)</li> <li>Incremental linear encoder (The signal resolution depends on the incremental linear encoder or Serial Converter Unit.)</li> </ul>								
Environmental Conditions	Surrounding Air Temperature <sup>*1</sup>	-5°C to 55°C With derating, usage is possible between 55°C and 60°C. Refer to the following section for derating specifications.  <b>Derating Specifications (page 307)</b>								
	Storage Temperature	-20°C to 85°C								
	Surrounding Air Humidity	95% relative humidity max. (with no freezing or condensation)								
	Storage Humidity	95% relative humidity max. (with no freezing or condensation)								
	Vibration Resistance	4.9 m/s <sup>2</sup>								
	Shock Resistance	19.6 m/s <sup>2</sup>								
	Degree of Protection	<table border="1"> <thead> <tr> <th>Class</th> <th>SERVOPACK Model: SGD7S-</th> </tr> </thead> <tbody> <tr> <td>IP20</td> <td>R70A, R90A, 1R6A, 2R8A, 3R8A, 5R5A, 7R6A, 120A</td> </tr> <tr> <td>IP10</td> <td>180A, 200A, 330A, 470A, 550A, 590A, 780A</td> </tr> </tbody> </table>		Class	SERVOPACK Model: SGD7S-	IP20	R70A, R90A, 1R6A, 2R8A, 3R8A, 5R5A, 7R6A, 120A	IP10	180A, 200A, 330A, 470A, 550A, 590A, 780A	
		Class	SERVOPACK Model: SGD7S-							
		IP20	R70A, R90A, 1R6A, 2R8A, 3R8A, 5R5A, 7R6A, 120A							
	IP10	180A, 200A, 330A, 470A, 550A, 590A, 780A								
Pollution Degree	2 <ul style="list-style-type: none"> <li>Must be no corrosive or flammable gases.</li> <li>Must be no exposure to water, oil, or chemicals.</li> <li>Must be no dust, salts, or iron dust.</li> </ul>									
Altitude <sup>*1</sup>	1,000 m or less. With derating, usage is possible between 1,000 m and 2,000 m. Refer to the following section for derating specifications.  <b>Derating Specifications (page 307)</b>									
Others	Do not use the SERVOPACK in the following locations: Locations subject to static electricity noise, strong electromagnetic/magnetic fields, or radioactivity									
Applicable Standards		UL 61800-5-1, CSA C22.2 No.274, EN 50178, EN 61800-5-1, EN 55011 group 1 class A, EN 61000-6-2, EN 61000-6-4, EN 61800-3, IEC 61508-1 to 4, IEC 61800-5-2, IEC 62061, ISO 13849-1, and IEC 61326-3-1								
Mounting		<table border="1"> <thead> <tr> <th>Mounting</th> <th>SERVOPACK Model: SGD7S-</th> </tr> </thead> <tbody> <tr> <td>Base-mounted</td> <td>All Models</td> </tr> <tr> <td>Rack-mounted</td> <td>R70A, R90A, 1R6A, 2R8A, 3R8A, 5R5A, 7R6A, 120A, 180A, 200A, 330A</td> </tr> <tr> <td>Duct-ventilated</td> <td>470A, 550A, 590A, 780A</td> </tr> </tbody> </table>	Mounting	SERVOPACK Model: SGD7S-	Base-mounted	All Models	Rack-mounted	R70A, R90A, 1R6A, 2R8A, 3R8A, 5R5A, 7R6A, 120A, 180A, 200A, 330A	Duct-ventilated	470A, 550A, 590A, 780A
Mounting	SERVOPACK Model: SGD7S-									
Base-mounted	All Models									
Rack-mounted	R70A, R90A, 1R6A, 2R8A, 3R8A, 5R5A, 7R6A, 120A, 180A, 200A, 330A									
Duct-ventilated	470A, 550A, 590A, 780A									
Performance	Speed Control Range	1:5000 (At the rated torque, the lower limit of the speed control range must not cause the Servo Motor/Servo Motor to stop.)								
	Coefficient of Speed Fluctuation <sup>*2</sup>	±0.01% of rated speed max. (for a load fluctuation of 0% to 100%)								
		0% of rated speed max. (for a voltage fluctuation of ±10%)								
		±0.1% of rated speed max. (for a temperature fluctuation of 25°C ±25°C)								
	Torque Control Precision (Repeatability)	±1%								
Soft Start Time Setting	0 s to 10 s (Can be set separately for acceleration and deceleration.)									

Continued from previous page.

Item		Specification	
I/O Signals	Encoder Divided Pulse Output	Phase A, phase B, phase C: Line-driver output Number of divided output pulses: Any setting is allowed.	
	Linear Servo Motor Overheat Protection Signal Input	Number of input points: 1 Input voltage range: 0 V to +5 V	
	Sequence Input Signals	Input Signals That Can Be Allocated	Allowable voltage range: 24 VDC ±20% Number of input points: 7
			Input method: Sink inputs or source inputs Input Signals: <ul style="list-style-type: none"> <li>• Origin Return Deceleration Switch (/DEC)</li> <li>• External Latch 1 to 3 (/EXT 1 to 3)</li> <li>• Forward Drive Prohibit (P-OT) and Reverse Drive Prohibit (N-OT)</li> <li>• Forward External Torque Limit (/P-CL) and Reverse External Torque Limit (/N-CL)</li> <li>• Polarity Detection (/P-DET)</li> </ul> A signal can be allocated and the positive and negative logic can be changed.
	Sequence Output Signals	Fixed Output	Allowable voltage range: 5 VDC to 30 VDC Number of output points: 1 Output signal: Servo Alarm (ALM)
		Output Signals That Can Be Allocated	Allowable voltage range: 5 VDC to 30 VDC Number of output points: 3 (A photocoupler output (isolated) is used.) Output Signals: <ul style="list-style-type: none"> <li>• Positioning Completion (/COIN)</li> <li>• Speed Coincidence Detection (/V-CMP)</li> <li>• Rotation Detection (/TGON)</li> <li>• Servo Ready Output (/S-RDY)</li> <li>• Torque Limit Detection (/CLT)</li> <li>• Speed Limit Detection (/VLT)</li> <li>• Brake (/BK)</li> <li>• Warning Output (/WARN)</li> <li>• Near Output (/NEAR)</li> </ul> A signal can be allocated and the positive and negative logic can be changed.
Communications	RS-422A Communications (CN3)	Interfaces	Digital Operator (JUSP-OP05A-1-E) and personal computer (with SigmaWin+)
		1:N Communications	Up to N = 15 stations possible for RS-422A port
		Axis Address Setting	Set with parameters.
	USB Communications (CN7)	Interface	Personal computer (with SigmaWin+)
		Communications Standard	Conforms to USB2.0 standard (12 Mbps).
Displays/Indicators		CHARGE, PWR, and COM indicators, and one-digit seven-segment display	

Continued from previous page.

Item		Specification
EtherCAT Communications	Applicable Communications Standards	IEC 61158 Type 12, IEC 61800-7 CiA402 Drive Profile
	Physical Layer	100BASE-TX (IEEE 802.3)
	Communications Connectors	CN6A (RJ45): EtherCAT signal input connector CN6B (RJ45): EtherCAT signal output connector
	Cable	Category 5, 4 shielded twisted pairs * The cable is automatically detected with AUTO MDIX.
	Sync Manager	SM0: Mailbox output, SM1: Mailbox input, SM2: Process data output, and SM3: Process data input
	FMMU	FMMU 0: Mapped in process data output (RxPDO) area. FMMU 1: Mapped in process data input (TxPDO) area. FMMU 2: Mapped to mailbox status.
	EtherCAT Commands (Data Link Layer)	APRD, FPRD, BRD, LRD, APWR, FPWR, BWR, LWR, ARMW, and FRMW (APRW, FPRW, BRW, and LRW commands are not supported.)
	Process Data	Assignments can be changed with PDO mapping.
	Mailbox (CoE)	Emergency messages, SDO requests, SDO responses, and SDO information (TxPDO/RxPDO and remote TxPDO/RxPDO are not supported.)
	Distributed Clocks	Free-Run Mode and DC Mode (Can be switched.) Applicable DC cycles: 125 μs to 4 ms in 125-μs increments
	Slave Information Interface	256 bytes (read-only)
	Indicators	EtherCAT communications in progress: Link/Activity x 2 EtherCAT communications status: RUN x 1 EtherCAT error status: ERR x 1
CiA402 Drive Profile	<ul style="list-style-type: none"> <li>• Homing Mode</li> <li>• Profile Position Mode</li> <li>• Interpolated Position Mode</li> <li>• Profile Velocity Mode</li> <li>• Profile Torque Mode</li> <li>• Cyclic Synchronous Position Mode</li> <li>• Cyclic Synchronous Velocity Mode</li> <li>• Cyclic Synchronous Torque Mode</li> <li>• Touch Probe Function</li> <li>• Torque Limit Function</li> </ul>	
Analog Monitor (CN5)	Number of points: 2 Output voltage range: ±10 VDC (effective linearity range: ±8 V) Resolution: 16 bits Accuracy: ±20 mV (Typ) Maximum output current: ±10 mA Settling time (±1%): 1.2 ms (Typ)	
Dynamic Brake (DB)	Activated when a servo alarm or overtravel (OT) occurs, or when the power supply to the main circuit or servo is OFF.	
Regenerative Processing	Built-in (An external resistor must be connected to the SGD7S-470A to -780A.)  <i>Built-In Regenerative Resistor (page 385)</i>	
Overtravel (OT) Prevention	Stopping with dynamic brake, deceleration to a stop, or coasting to a stop for the P-OT (Forward Drive Prohibit) or N-OT (Reverse Drive Prohibit) signal	
Protective Functions	Overcurrent, overvoltage, low voltage, overload, regeneration error, etc.	
Utility Functions	Gain adjustment, alarm history, jogging, origin search, etc.	
Safety Functions	Inputs	/HWBB1 and /HWBB2: Base block signals for Power Modules
	Output	EDM1: Monitors the status of built-in safety circuit (fixed output).
	Applicable Standards <sup>13</sup>	ISO13849-1 PLe (Category 3), IEC61508 SIL3
Option Module	Fully-Closed Modules and Safety Modules Note: You cannot use a Fully-Closed Module and a Safety Module together.	

## SERVOPACKs

### $\Sigma$ -7S Single-axis EtherCAT Communications Reference SERVOPACKs

---

\*1. If you combine a  $\Sigma$ -7-Series SERVOPACK with a  $\Sigma$ -V-Series Option Module, the following  $\Sigma$ -V-Series SERVOPACKs specifications must be used: a surrounding air temperature of 0°C to 55°C and an altitude of 1,000 m max. Also, the applicable range cannot be increased by derating.

\*2. The coefficient of speed fluctuation for load fluctuation is defined as follows:

$$\text{Coefficient of speed fluctuation} = \frac{\text{No-load motor speed} - \text{Total-load motor speed}}{\text{Rated motor speed}} \times 100\%$$

\*3. Always perform risk assessment for the system and confirm that the safety requirements are met.

## Derating Specifications

If you use the SERVOPACK at a surrounding air temperature of 55°C to 60°C or at an altitude of 1,000 m to 2,000 m, you must apply the derating rates given in the following graphs.

### ◆ SGD7S-R70A, -R90A, -1R6A, and -2R8A

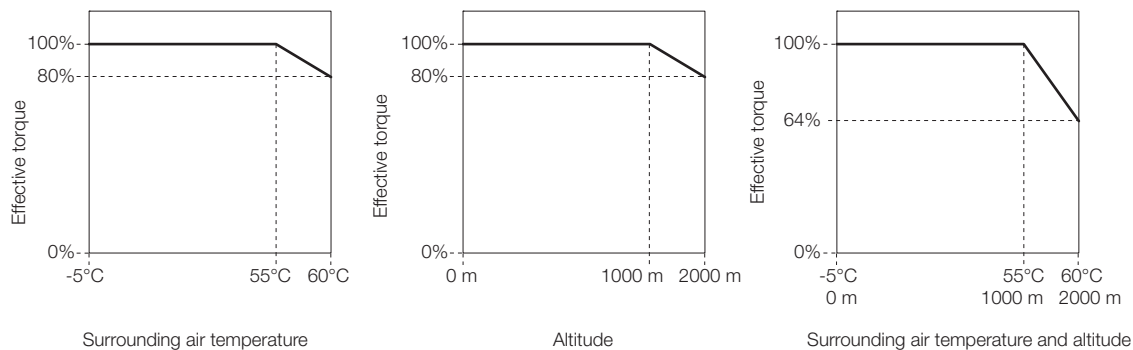

### ◆ SGD7S-3R8A, -5R5A, -7R6A, -120A, -180A, -200A, -330A, -470A, -550A, -590A, and -780A

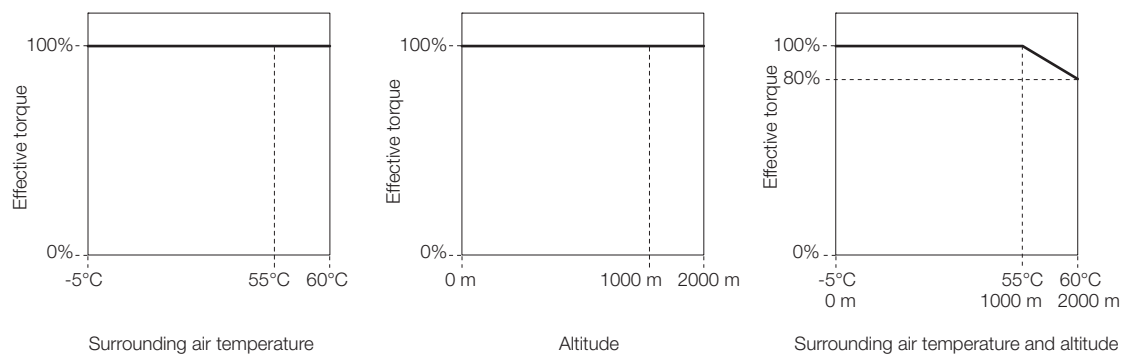

## Model Designations

SGD7W - 1R6 A 30 A 700

Σ-7 Series  
Σ-7W SERVOPACKs

1st+2nd+3rd  
digits

4th  
digit

5th+6th  
digits

7th  
digit

8th+9th+10th  
digits

1st+2nd+3rd digits

Maximum Applicable  
Motor Capacity per Axis

Voltage	Code	Specification
Three-phase, 200 VAC	1R6*1	0.2 kW
	2R8*1	0.4 kW
	5R5*1	0.75 kW
	7R6	1.0 kW

4th digit

Voltage

Code	Specification
A	200 VAC

8th+9th+10th digits

Hardware Options  
Specification

Code	Specification	Applicable Models
700*3	HWBB option	All models

5th+6th digits

Interface\*2

Code	Specification
20	MECHATROLINK-III communications reference with IMI connector (0.75 kW and 1.0 kW Units)
30	MECHATROLINK-III communications reference with RJ45 connector (0.2 kW and 0.4 kW Units)

7th digit

Design Revision Order

A: Global design revision

\*1. You can use these models with either a single-phase or three phase power supply input

\*2. The same SERVOPACKs are used for both Rotary Servo Motors and Linear Servo Motors

\*3. Refer to the following manual for details

Sigma-7 Series AC Servo Drive SGD7W SERVOPACK with Hardware Option Specifications HWBB Function Product Manual  
(Manual No: SIEPS800000172)



## Ratings and Specifications

### Ratings

#### ◆ Three-phase, 200 VAC

Model SGD7W-		1R6A	2R8A	5R5A	7R6A	
Maximum Applicable Motor Capacity per Axis [kW]		0.2	0.4	0.75	1.0	
Continuous Output Current per Axis [Arms]		1.6	2.8	5.5	7.6	
Instantaneous Maximum Output Current per Axis [Arms]		5.9	9.3	16.9	17.0	
Main Circuit	Power Supply	200 VAC to 240 VAC, -15% to +10%, 50 Hz/60 Hz				
	Input Current [Arms]*	2.5	4.7	7.8	11	
Control Power Supply		200 VAC to 240 VAC, -15% to +10%, 50 Hz/60 Hz				
Power Supply Capacity [kVA]*		1.0	1.9	3.2	4.5	
Power Loss*	Main Circuit Power Loss [W]	27.0	48.0	87.6	107.2	
	Control Circuit Power Loss [W]	24	24	24	24	
	Built-in Regenerative Resistor Power Loss [W]	8	8	16	16	
	Total Power Loss [W]	59.0	80.0	127.6	147.2	
Regenerative Resistor	Built-In Regenerative Resistor	Resistance [Ω]	40	40	12	12
		Capacity [W]	40	40	60	60
	Minimum Allowable External Resistance [Ω]	40	40	40	40	
Overvoltage Category		III				

\* This is the net value at the rated load.

#### ◆ Single-phase, 200 VAC

Model SGD7W-		1R6A	2R8A	5R5A <sup>*1</sup>	
Maximum Applicable Motor Capacity per Axis [kW]		0.2	0.4	0.75	
Continuous Output Current per Axis [Arms]		1.6	2.8	5.5	
Instantaneous Maximum Output Current per Axis [Arms]		5.9	9.3	16.9	
Main Circuit	Power Supply	200 VAC to 240 VAC, -15% to +10%, 50 Hz/60 Hz			
	Input Current [Arms] <sup>*2</sup>	5.5	11	12	
Control Power Supply		200 VAC to 240 VAC, -15% to +10%, 50 Hz/60 Hz			
Power Supply Capacity [kVA] <sup>*2</sup>		1.3	2.4	2.7	
Power Loss <sup>*2</sup>	Main Circuit Power Loss [W]	27.0	48.0	87.6	
	Control Circuit Power Loss [W]	24	24	24	
	Built-in Regenerative Resistor Power Loss [W]	8	8	16	
	Total Power Loss [W]	59.0	80.0	127.6	
Regenerative Resistor	Built-In Regenerative Resistor	Resistance [Ω]	40	40	12
		Capacity [W]	40	40	60
	Minimum Allowable External Resistance [Ω]	40	40	40	
Overvoltage Category		III			

\*1. If you use the SGD7W-5R5A with a single-phase 200-VAC power supply input, derate the load ratio to 65%. An example is given below.

If the load ratio of the first axis is 90%, use a load ratio of 40% for the second axis so that average load ratio for both axes is 65% ( $(90\% + 40\%)/2 = 65\%$ ).

\*2. This is the net value at the rated load.

## SERVOPACKs

Σ-7W Two-axis MECHATROLINK-III Communications Reference SERVOPACKs

### ◆ 270 VDC

Model SGD7W-		1R6A	2R8A	5R5A	7R6A
Maximum Applicable Motor Capacity [kW]		0.2	0.4	0.75	1.0
Continuous Output Current [Arms]		1.6	2.8	5.5	7.6
Instantaneous Maximum Output Current [Arms]		5.9	9.3	16.9	17.0
Main Circuit	Power Supply	270 VDC to 324 VDC, -15% to +10%			
	Input Current [Arms]*	3.0	5.8	9.7	14
Control Power Supply		270 VDC to 324 VDC, -15% to +10%			
Power Supply Capacity [kVA]*		1.2	2	3.2	4.6
Power Loss*	Main Circuit Power Loss [W]	23	40	76	92
	Control Circuit Power Loss [W]	24	24	24	24
	Total Power Loss [W]	47	64	100	116
Overvoltage Category		III			

\* This is the net value at the rated load.

## SERVOPACK Overload Protection Characteristics

The overload detection level is set for hot start conditions with a SERVOPACK surrounding air temperature of 55°C.

An overload alarm (A.710 or A.720) will occur if overload operation that exceeds the overload protection characteristics shown in the following diagram (i.e., operation on the right side of the applicable line) is performed.

The actual overload detection level will be the detection level of the connected SERVOPACK or Servo Motor that has the lower overload protection characteristics.

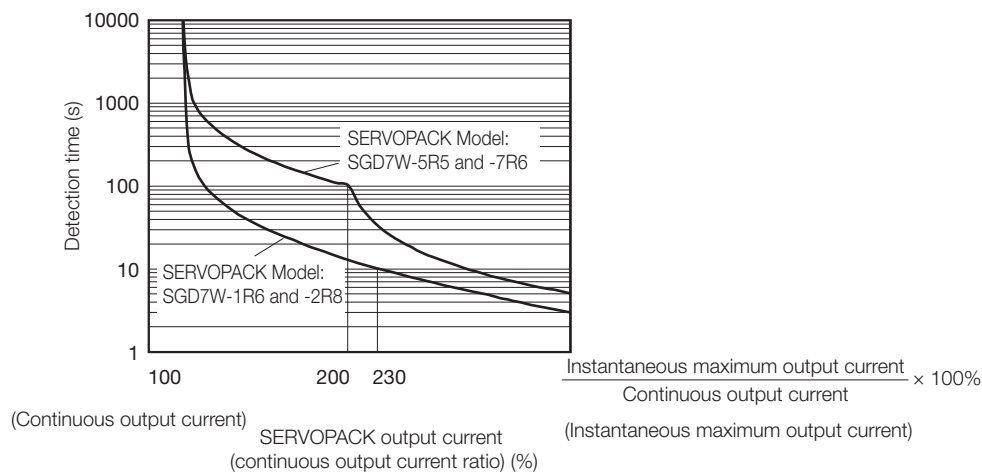

In most cases, that will be the overload protection characteristics of the Servo Motor.



Note: The above overload protection characteristics do not mean that you can perform continuous duty operation with an output of 100% or higher.

For a Yaskawa-specified combination of SERVOPACK and Servo Motor, maintain the effective torque (or effective force) within the continuous duty zone of the torque-motor speed characteristic (or force-motor speed characteristics) of the Servo Motor.

## Specifications

Item		Specification
Control Method		IGBT-based PWM control, sine wave current drive
Feedback	With Rotary Servo Motor	Serial encoder: 20 bits or 24 bits (incremental encoder/absolute encoder)
	With Linear Servo Motor	<ul style="list-style-type: none"> <li>Absolute linear encoder (The signal resolution depends on the absolute linear encoder.)</li> <li>Incremental linear encoder (The signal resolution depends on the incremental linear encoder or Serial Converter Unit.)</li> </ul>
Environmental Conditions	Surrounding Air Temperature	-5°C to 55°C With derating, usage is possible between 55°C and 60°C. Refer to the following section for derating specifications.  <i>Derating Specifications</i> (page 314)
	Storage Temperature	-20°C to 85°C
	Surrounding Air Humidity	95% relative humidity max. (with no freezing or condensation)
	Storage Humidity	95% relative humidity max. (with no freezing or condensation)
	Vibration Resistance	4.9 m/s <sup>2</sup>
	Shock Resistance	19.6 m/s <sup>2</sup>
	Degree of Protection	IP20
	Pollution Degree	2 <ul style="list-style-type: none"> <li>Must be no corrosive or flammable gases.</li> <li>Must be no exposure to water, oil, or chemicals.</li> <li>Must be no dust, salts, or iron dust.</li> </ul>
	Altitude	1,000 m or less. With derating, usage is possible between 1,000 m and 2,000 m. Refer to the following section for derating specifications.  <i>Derating Specifications</i> (page 314)
Others	Do not use the SERVOPACK in the following locations: Locations subject to static electricity noise, strong electromagnetic/magnetic fields, or radioactivity	
Applicable Standards		UL 61800-5-1, CSA C22.2 No.274, EN50178, EN 61800-5-1, EN 55011 group 1 class A, EN 61000-6-2, EN 61000-6-4, and EN 61800-3
Mounting		Base-mounted or rack-mounted
Performance	Speed Control Range	1:5000 (At the rated torque, the lower limit of the speed control range must not cause the Servo Motor to stop.)
	Coefficient of Speed Fluctuation*	±0.01% of rated speed max. (for a load fluctuation of 0% to 100%)
		±0.1% of rated speed max. (for a temperature fluctuation of 25°C ±25°C)
	Torque Control Precision (Repeatability)	±1%
Soft Start Time Setting	0 s to 10 s (Can be set separately for acceleration and deceleration.)	

Continued on next page.

**SERVOPACKs**

Σ-7W Two-axis MECHATROLINK-III Communications Reference SERVOPACKs

Continued from previous page.

Item		Specification		
I/O Signals	Linear Servo Motor Overheat Protection Signal Input	Number of input points: 2 Input voltage range: 0 V to +5 V		
	Sequence Input Signals	Input Signals That Can Be Allocated		
		Input Signals	Allowable voltage range: 24 VDC ±20% Number of input points: 12 Input method: Sink inputs or source inputs • Origin Return Deceleration Switch (/DEC) • External Latch (/EXT 1 to 3) • Forward Drive Prohibit (P-OT) and Reverse Drive Prohibit (N-OT) • Forward External Torque Limit (/P-CL) and Reverse External Torque Limit (/N-CL) • Polarity Detection (/P-DET) A signal can be allocated and the positive and negative logic can be changed.	
	Sequence Output Signals	Fixed Output	Allowable voltage range: 5 VDC to 30 VDC Number of output points: 2 Output signal: Servo Alarm (ALM)	
		Output Signals That Can Be Allocated	Output Signals	Allowable voltage range: 5 VDC to 30 VDC Number of output points: 5 (A photocoupler output (isolated) is used.) • Positioning Completion (/COIN) • Speed Coincidence Detection (/V-CMP) • Rotation Detection (/TGON) • Servo Ready (/S-RDY) • Torque Limit Detection (/CLT) • Speed Limit Detection (/VLT) • Brake (/BK) • Warning (/WARN) • Near (/NEAR) A signal can be allocated and the positive and negative logic can be changed.
Communications	RS-422A Communications (CN3)	Inter- faces	Digital Operator (JUSP-OP05A-1-E) and personal computer (with SigmaWin+)	
		1:N Commu- nica- tions	Up to N = 15 stations possible for RS-422A port	
		Axis Address Settings	Set with parameters.	
	USB Commu- nica- tions (CN7)	Inter- face	Personal computer (with SigmaWin+)	
		Commu- nica- tions Stan- dard	Conforms to USB2.0 standard (12 Mbps).	
Displays/Indicators		CHARGE, PWR, COM, L1, and L2 indicators, and two, one-digit seven-segment displays		

Continued on next page.

Continued from previous page.

Item		Specification
MECHA-TROLINK-III Commu-nications	Communications Protocol	MECHATROLINK-III
	Station Address Settings	03 to EF hex (maximum number of slaves: 62) The rotary switches (S1 and S2) are used to set the station address.
	Extended Address Setting	Axis 1: 00 hex, Axis 2: 01 hex
	Baud Rate	100 Mbps
	Transmission Cycle	250 μs, 500 μs, 750 μs, 1.0 ms to 4.0 ms (multiples of 0.5 ms)
	Number of Transmis-sion Bytes	32 or 48 bytes/station A DIP switch (S3) is used to select the baud rate.
Reference Method	Performance	Position, speed, or torque control with MECHATROLINK-III communi-cations
	Reference Input	MECHATROLINK-III commands (sequence, motion, data setting, data access, monitoring, adjustment, etc.)
	Profile	MECHATROLINK-III standard servo profile
MECHATROLINK-III Commu-nications Setting Switches		Rotary switch (S1 and S2) positions: 16
		Number of DIP switch (S3) pins: 4
Analog Monitor (CN5)		Number of points: 2 Output voltage range: ±10 VDC (effective linearity range: ±8 V) Resolution: 16 bits Accuracy: ±20 mV (Typ) Maximum output current: ±10 mA Settling time (±1%): 1.2 ms (Typ)
Dynamic Brake (DB)		Activated when a servo alarm or overtravel (OT) occurs, or when the power supply to the main circuit or servo is OFF.
Regenerative Processing		Built-in
Overtravel (OT) Prevention		Stopping with dynamic brake, deceleration to a stop, or coasting to a stop for the P-OT (Forward Drive Prohibit) or N-OT (Reverse Drive Prohibit) signal
Protective Functions		Overcurrent, overvoltage, low voltage, overload, regeneration error, etc.
Utility Functions		Gain adjustment, alarm history, jogging, origin search, etc.
Option Module		Option Module cannot be attached.

\* The coefficient of speed fluctuation for load fluctuation is defined as follows:

$$\text{Coefficient of speed fluctuation} = \frac{\text{No-load motor speed} - \text{Total-load motor speed}}{\text{Rated motor speed}} \times 100\%$$

## Derating Specifications

If you use the SERVOPACK at a surrounding air temperature of 55°C to 60°C or at an altitude of 1,000 m to 2,000 m, you must apply the derating rates given in the following graphs.

### ◆ SGD7W-1R6A, -2R8A, -5R5A, and -7R6A

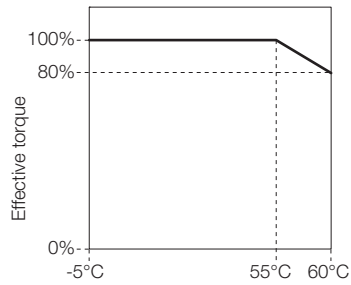

Surrounding air temperature

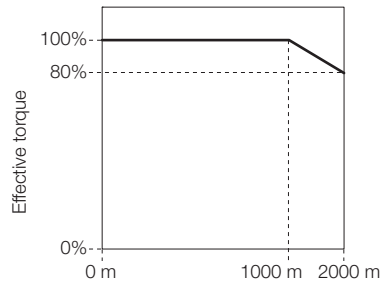

Altitude

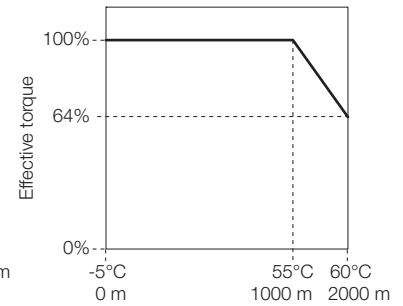

Surrounding air temperature and altitude



# SERVOPACK External Dimensions

## Front Cover Dimensions and Connector Specifications

The front cover dimensions and panel connectors depend on the SERVOPACK interface. Refer to the following figures.

### Front Cover Dimensions

- $\Sigma$ -7S Analog Voltage/Pulse Train Reference SERVOPACKs

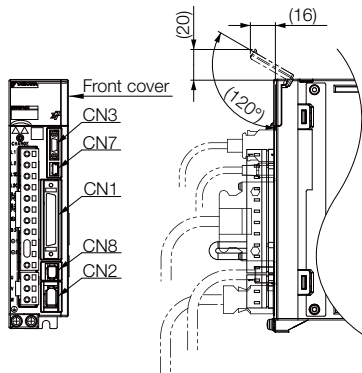

- $\Sigma$ -7S MECHATROLINK-III Communications Reference SERVOPACKs

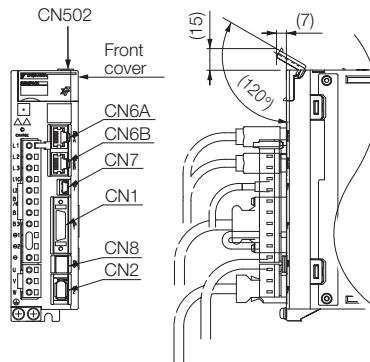

- $\Sigma$ -7S EtherCAT Communications Reference SERVOPACKs

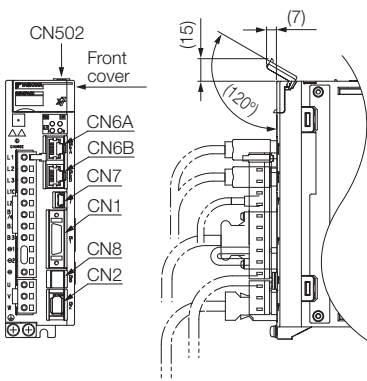

- $\Sigma$ -7W MECHATROLINK-III Communications Reference SERVOPACKs

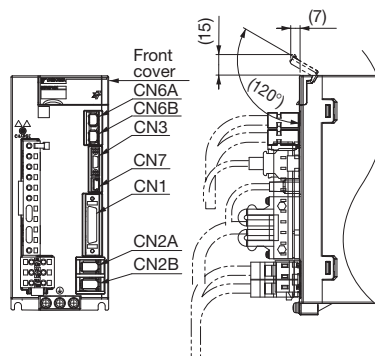

\* A Command Option Module must be attached to the Command Option Attachable-Type SERVOPACK. To find the dimensions of the SERVOPACK with a Command Option Module attached, add the dimensions of the Command Option Module (refer to page 240 and following pages).



## Connector Specifications

SERVOPACK	Connector No.	Model	Number of Pins	Manufacturer
Σ-7S Analog Voltage/Pulse Train Reference SERVOPACK	CN1	10250-59A3MB	50	3M Japan Ltd.
	CN2	3E106-0220KV	6	3M Japan Ltd.
	CN3	HDR-EC14LF- DTN-SLD-PLUS	14	Honda Tsushin Kogyo Co., Ltd.
	CN7	2172034-1	5	Tyco Electronics Japan G.K.
	CN8	1981080-1	8	Tyco Electronics Japan G.K.
Σ-7S MECHATROLINK-III Communications Reference SERVOPACK	CN1	10226-59A3MB	26	3M Japan Ltd.
	CN2	3E106-0220KV	6	3M Japan Ltd.
	CN502	S8B-ZR-SM4A-TF (LF)(SN)	8	J.S.T. Mfg. Co., Ltd.
	CN6A, CN6B	1-1734579-4	8	Tyco Electronics Japan G.K.
	CN7	2172034-1	5	Tyco Electronics Japan G.K.
	CN8	1981080-1	8	Tyco Electronics Japan G.K.
Σ-7S EtherCAT Communications Reference SERVOPACK	CN1	10226-59A3MB	26	3M Japan Ltd.
	CN2	3E106-0220KV	6	3M Japan Ltd.
	CN502	S8B-ZR-SM4A-TF (LF)(SN)	8	J.S.T. Mfg. Co., Ltd.
	CN6A, CN6B	1903815-1	8	Tyco Electronics Japan G.K.
	CN7	2172034-1	5	Tyco Electronics Japan G.K.
	CN8	1981080-1	8	Tyco Electronics Japan G.K.
Σ-7W MECHATROLINK-III Communications Reference SERVOPACK	CN1	10236-59A3MB	36	3M Japan Ltd.
	CN2A, CN2B	3E106-2230KV	6	3M Japan Ltd.
	CN3	HDR-EC14LF- DTN-SLD-PLUS	14	Honda Tsushin Kogyo Co., Ltd.
	CN6A, CN6B	1981386-1	8	Tyco Electronics Japan G.K.
	CN7	2172034-1	5	Tyco Electronics Japan G.K.

Note: The above connectors or their equivalents are used for the SERVOPACKs.

## SERVOPACK External Dimensions

### Σ-7S SERVOPACKs: Analog/Pulse and Command Option Type

All of the dimensional drawings show Analog Voltage/Pulse Train Reference SERVOPACKs as typical examples.

- ◆ Three-phase, 200 VAC: SGD7S-R70A, -R90A, and -1R6A
- Single-phase, 100 VAC: SGD7S-R70F, -R90F, - 2R1F

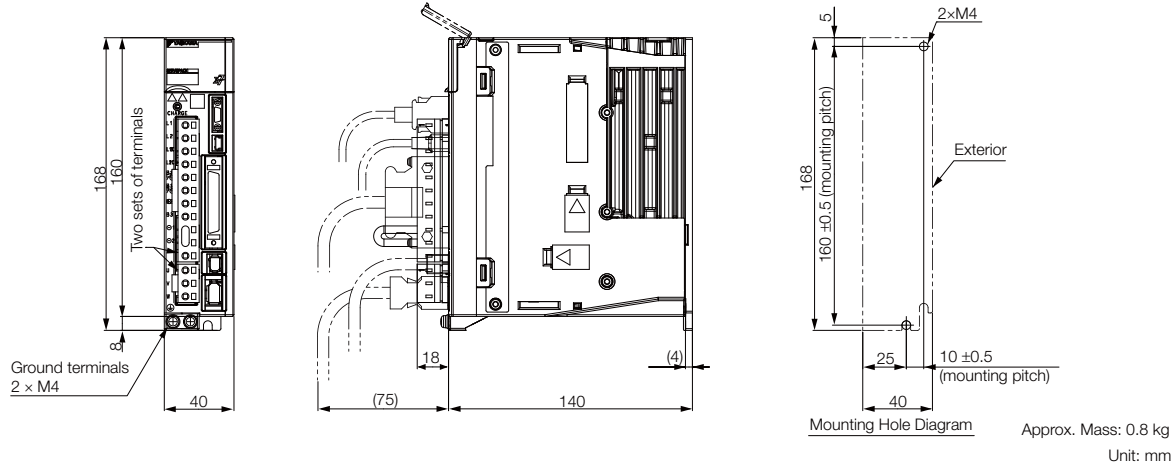

- ◆ Three-phase, 200 VAC: SGD7S-2R8A
- Single-phase, 100 VAC: SGD7S-2R8F

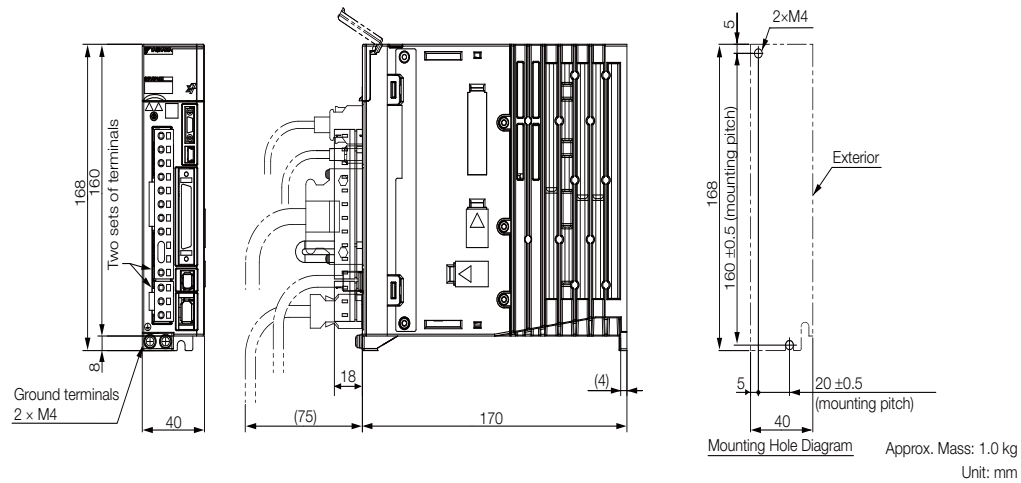

◆ Three-phase, 200 VAC: SGD7S-3R8A, -5R5A, and -7R6A

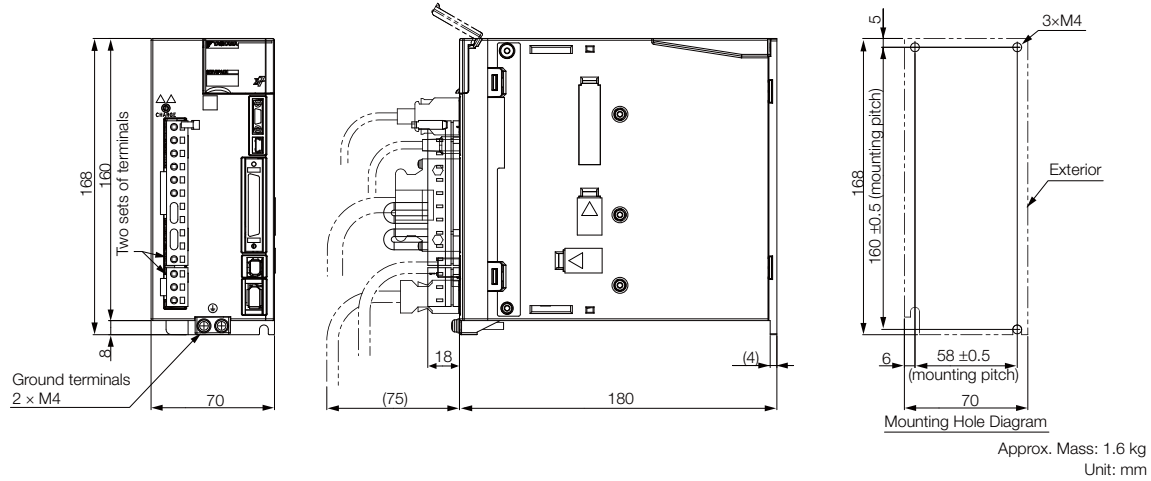

◆ Three-phase, 200 VAC: SGD7S-120A

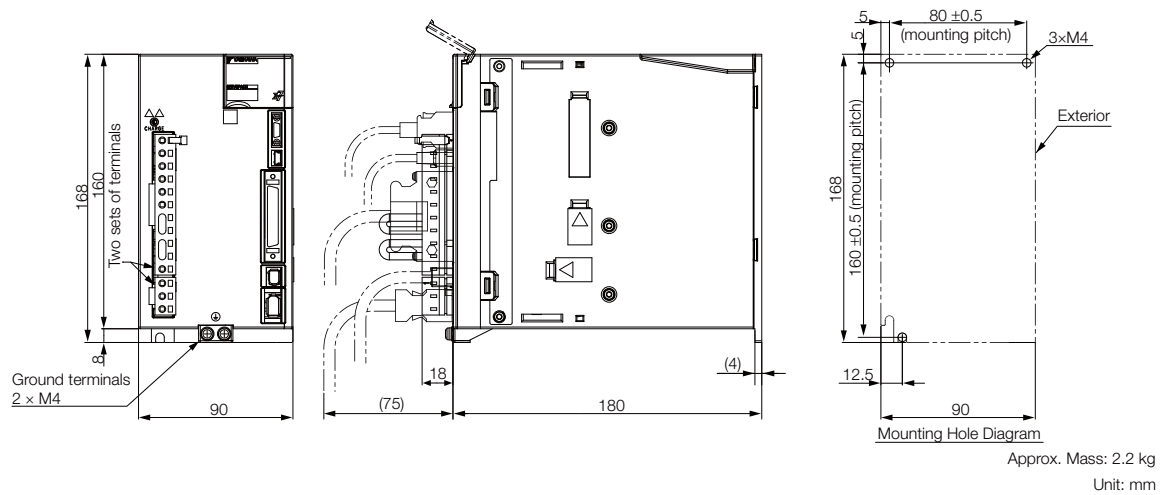

◆ Three-phase, 200 VAC: SGD7S-180A and -200A

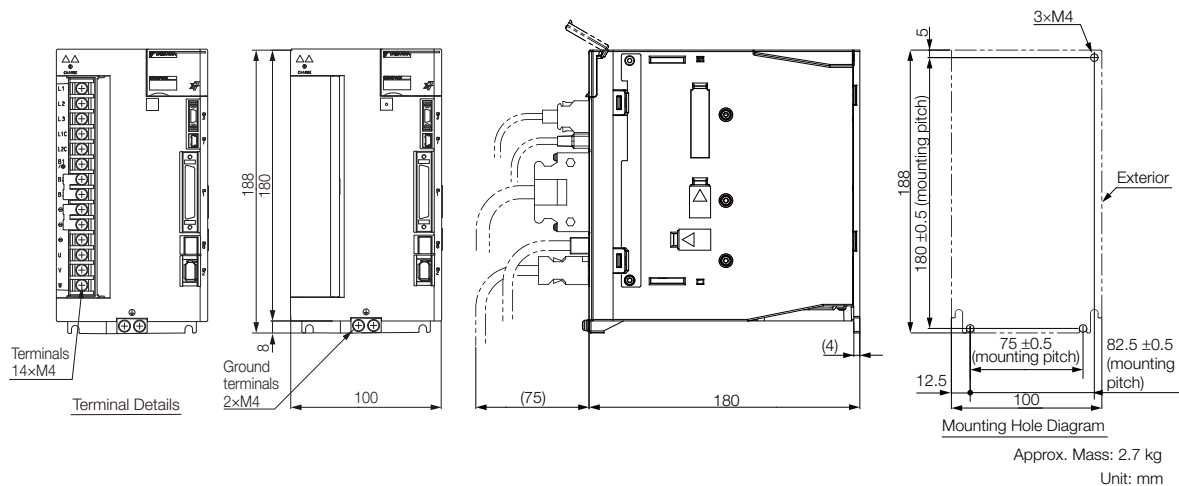

## SERVOPACKs

### SERVOPACK External Dimensions

#### ◆ Three-phase, 200 VAC: SGD7S-330A

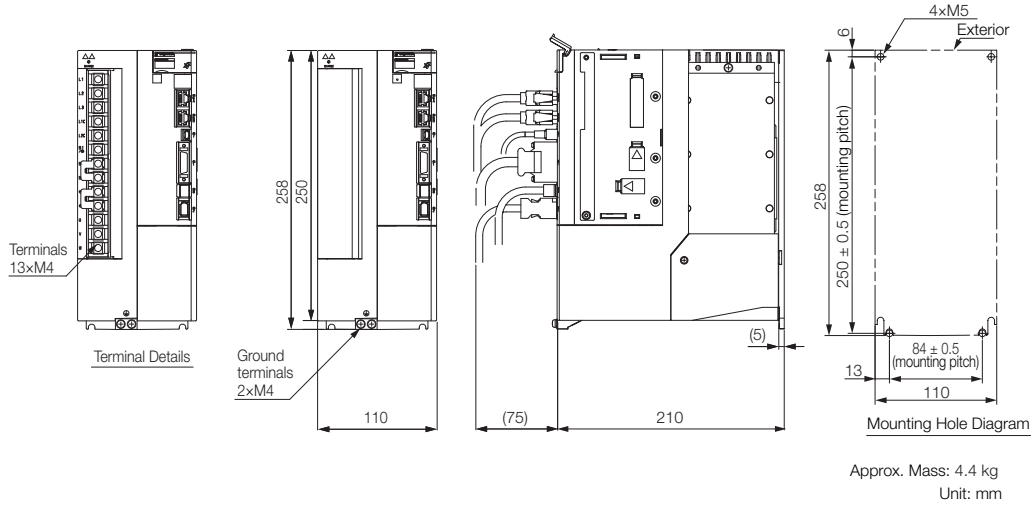

#### ◆ Three-phase, 200 VAC: SGD7S-470A and -550A

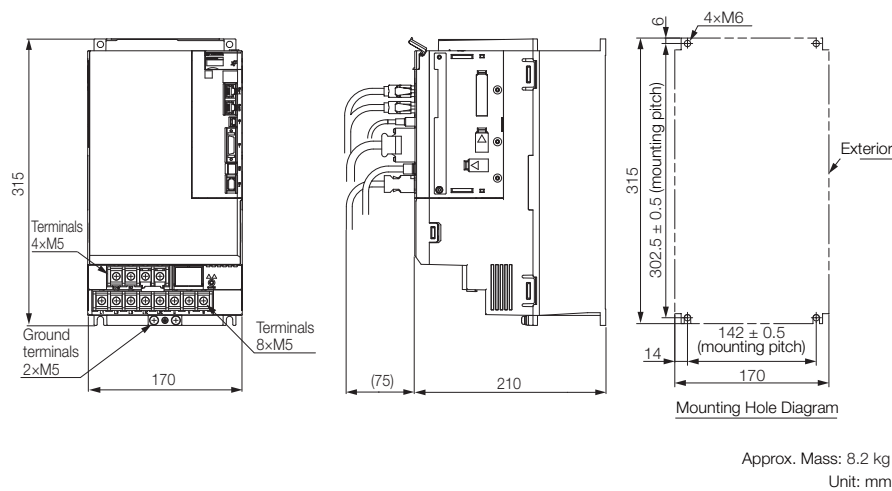

#### ◆ Three-phase, 200 VAC: SGD7S-590A and -780A

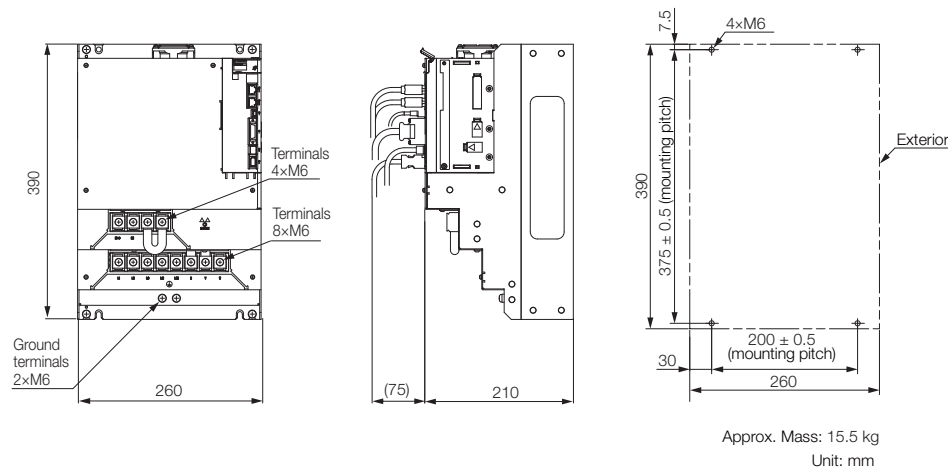

## Σ-7S SERVOPACKs: MECHATROLINK-III and EtherCAT Type

All of the dimensional drawings show MECHATROLINK-III Reference SERVOPACKs as typical examples.

- ◆ Three-phase, 200 VAC: SGD7S-R70A, -R90A, and -1R6A  
Single-phase, 100 VAC: SGD7S-R70F, -R90F, - 2R1F

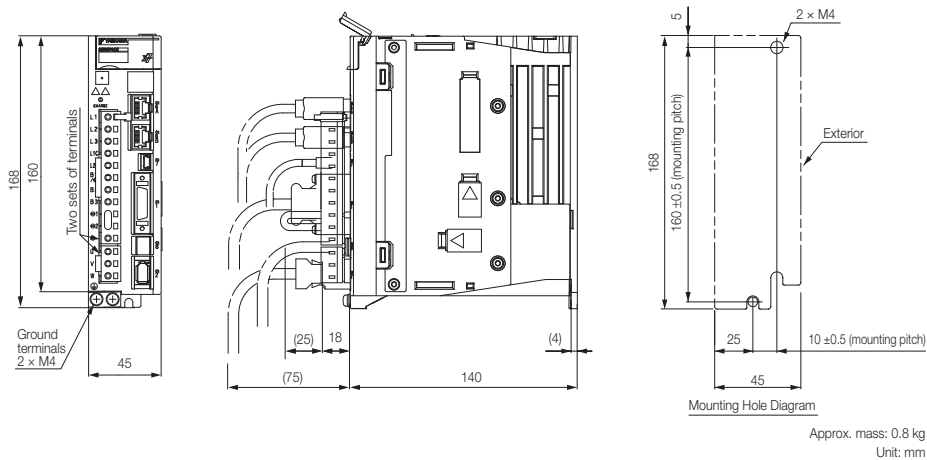

- ◆ Three-phase, 200 VAC: SGD7S-2R8A  
Single-phase, 100 VAC: SGD7S-2R8F

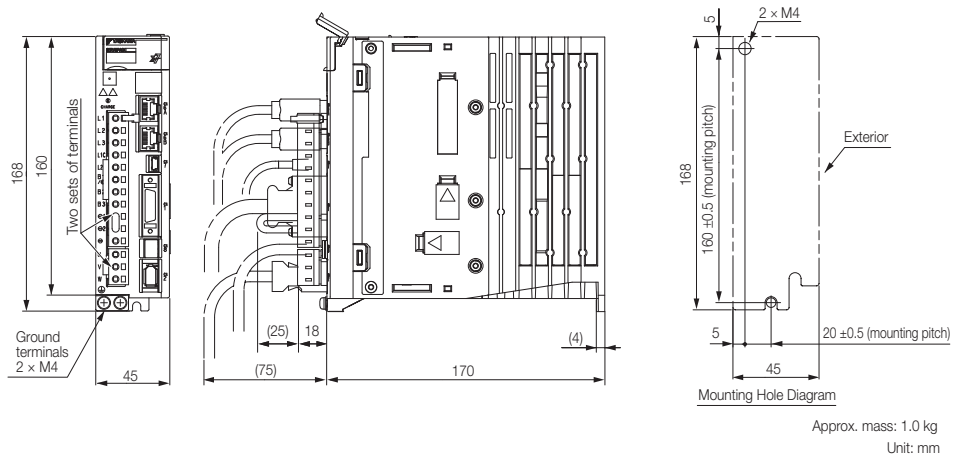

- ◆ Three-phase, 200 VAC: SGD7S-3R8A, -5R5A, and -7R6A

## SERVOPACKs

### SERVOPACK External Dimensions

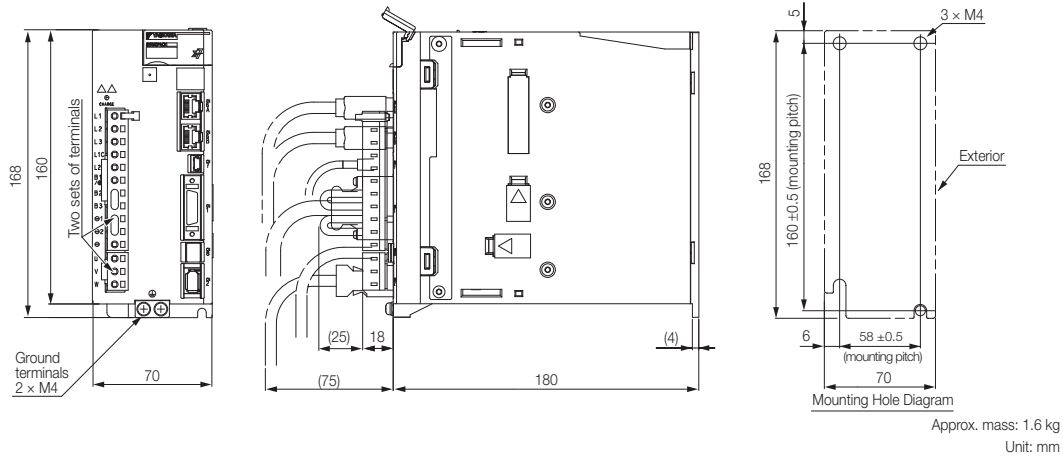

### ◆ Three-phase, 200 VAC: SGD7S-120A

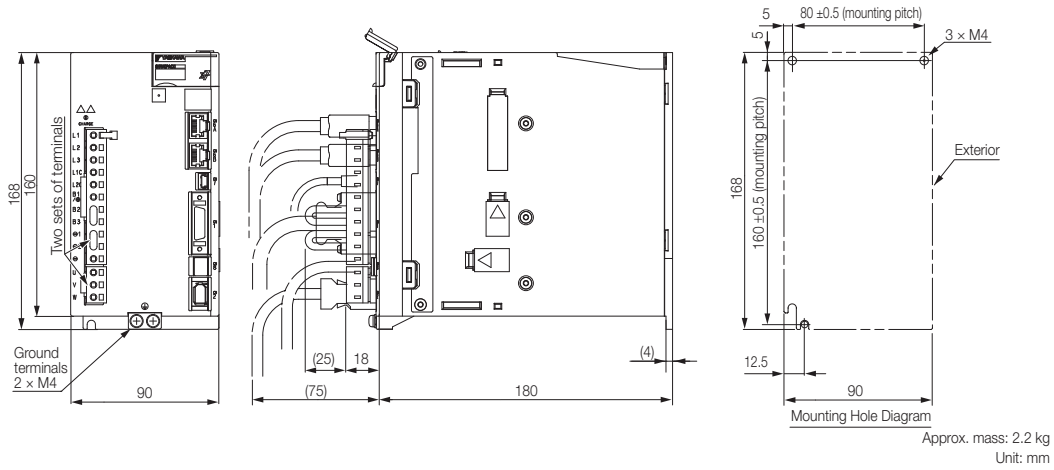

### ◆ Three-phase, 200 VAC: SGD7S-180A and -200A

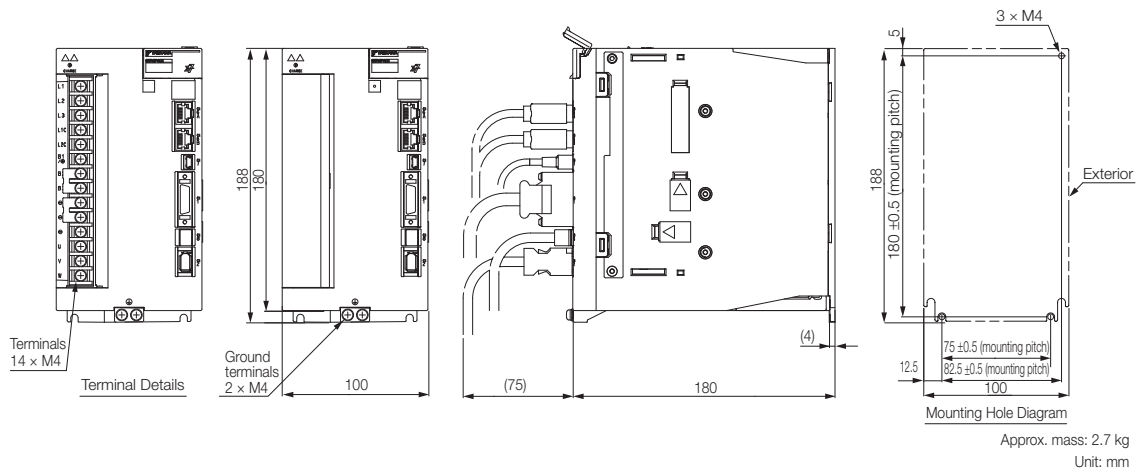

◆ Three-phase, 200 VAC: SGD7S-330A

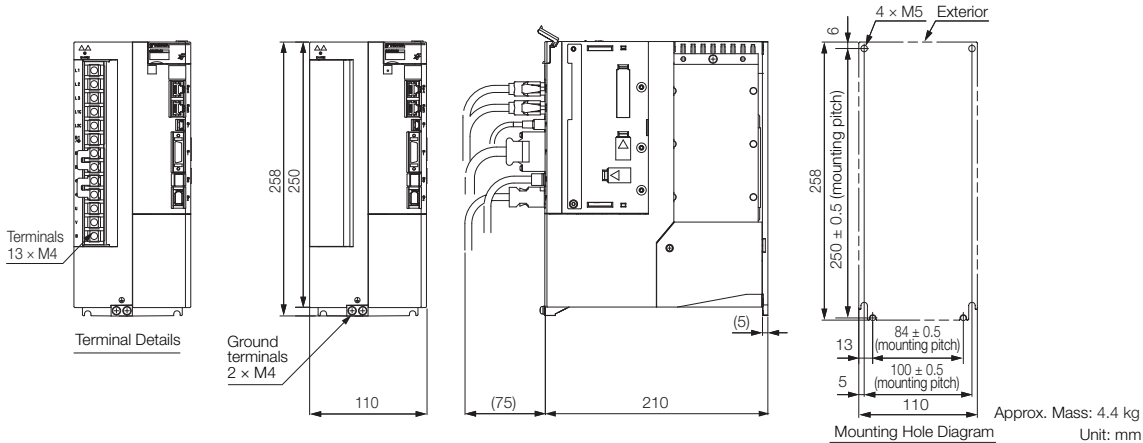

◆ Three-phase, 200 VAC: SGD7S-470A and -550A

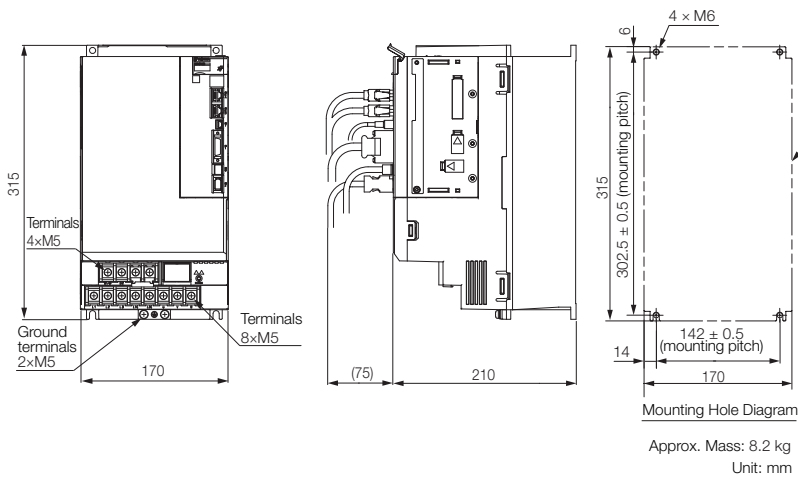

◆ Three-phase, 200 VAC: SGD7S-590A and -780A

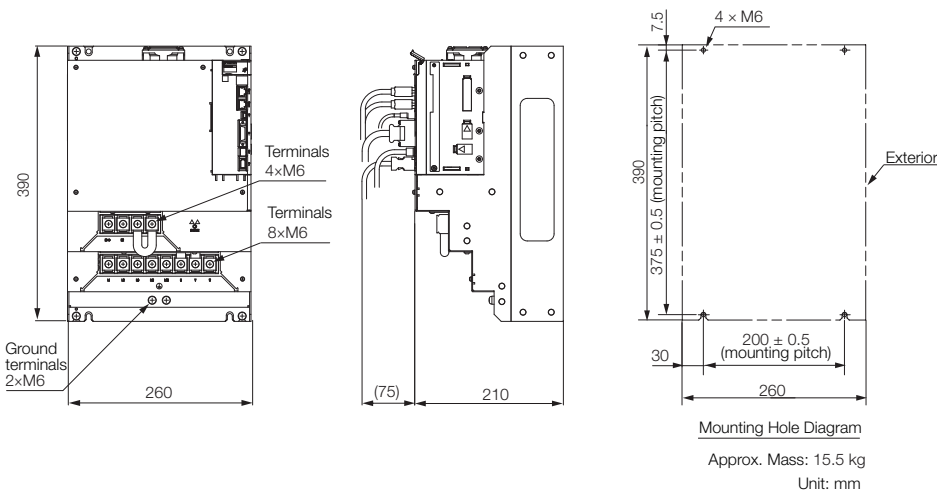

**SERVOPACKs**

SERVOPACK External Dimensions

**Σ-7W SERVOPACKs: Base-mounted**

◆ Three-phase, 200 VAC: SGD7W-1R6A and -2R8A

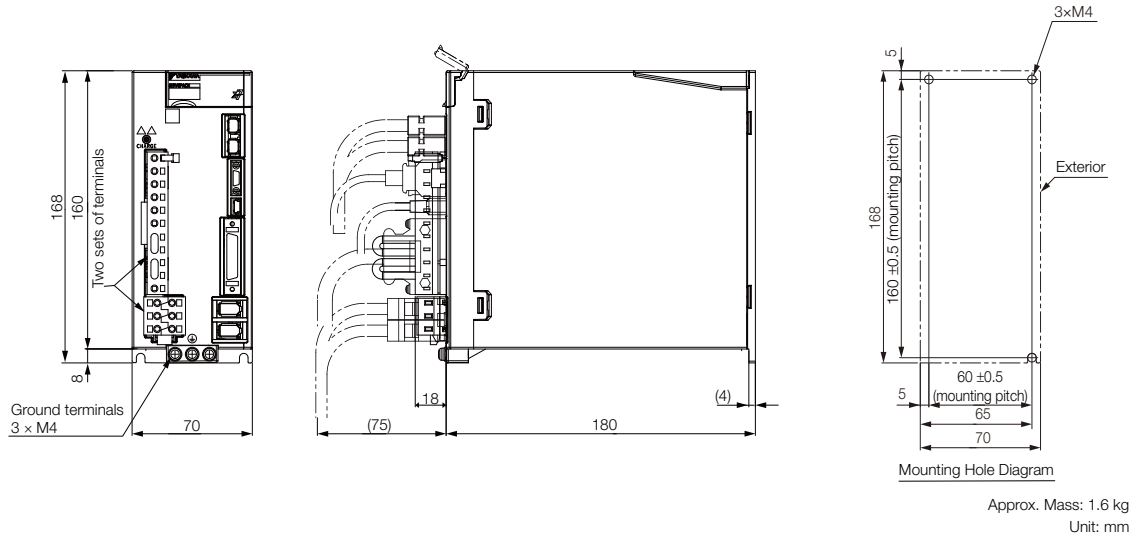

◆ Three-phase, 200 VAC: SGD7W-5R5A and -7R6A

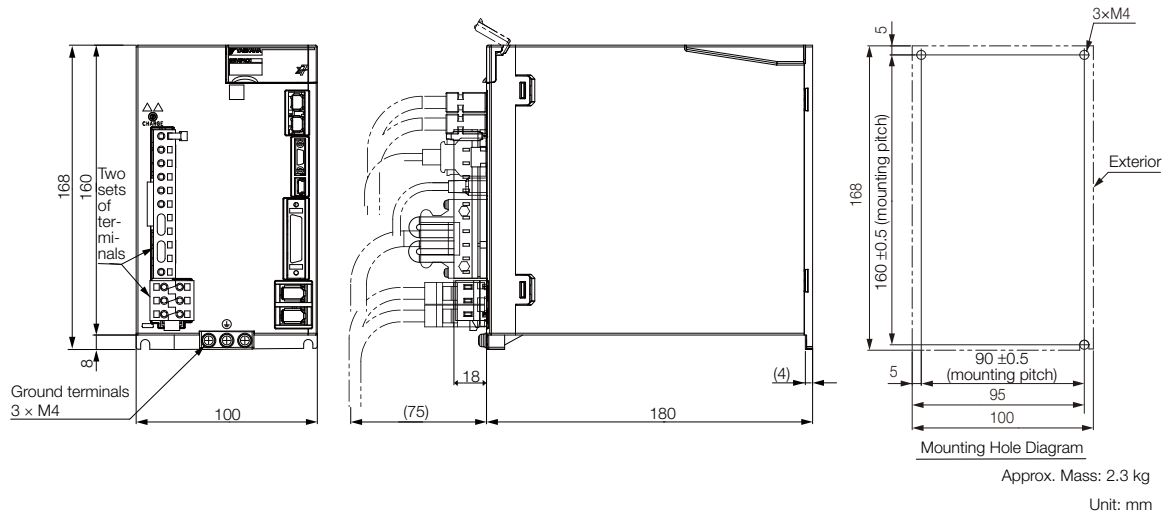



# Additional SERVOPACK Options

---

Feedback Option .....	326
Safety Option .....	332
Sigma-7Siec Option .....	336
MP2600iec Option .....	338
SigmaLogic7 Compact Option .....	346
FT19 Option - Less Deviation Control .....	348
FT79 Option - Built-in Indexer .....	350
FT81 Option - Harmonic Drive SHA Actuators .....	352

# Feedback Option

## Fully-Closed Loop Option

With fully-closed control, an externally installed encoder is used to detect the position of the controlled machine and the machine's position information is fed back to the SERVOPACK. High-precision positioning is possible because the actual machine position is fed back directly. To perform fully-closed loop control, the fully closed loop option must be selected.

## SERVOPACK Designations

### ◆ Purchasing a SERVOPACK with the fully closed loop option

To order SERVOPACKs with the fully-closed loop option, use the following model numbers.



1st+2nd+3rd digits Maximum Applicable Motor Capacity

Voltage	Code	Specification
Three-phase, 200 VAC	R70 <sup>*2</sup>	0.05 kW
	R90 <sup>*2</sup>	0.1 kW
	1R6 <sup>*2</sup>	0.2 kW
	2R8 <sup>*2</sup>	0.4 kW
	3R8	0.5 kW
	5R5 <sup>*2</sup>	0.75 kW
	7R6	1.0 kW
	120	1.5 kW
	180	2.0 kW
	200	3.0 kW
	330	5.0 kW
	470	6.0 kW
	550	7.5 kW
	590	11 kW
780	15 kW	
Single-phase, 100 VAC	R70	0.05 kW
	R90	0.1 kW
	2R1	0.2 kW
	2R8	0.4 kW

4th digit Voltage

Code	Specification
A	200 VAC
F	100 VAC

5th+6th digits Interface

Code	Specification
00	Analog voltage/pulse train reference
30	MECHATROLINK-III communications reference
A0	EtherCAT communications reference

7th digit Design Revision Order

A: Global design revision

8th+9th+10th digits Hardware Options Specification

Code	Specification	Applicable Models
000	Without options	All models

11th+12th+13th digits Option Module

Code	Specification
001	Fully-Closed Module

\*1. The model number of a SERVOPACK with an Option is not hyphenated after SGD7S.

\*2. You can use these models with either a single-phase or three-phase power supply input.

# System Configuration

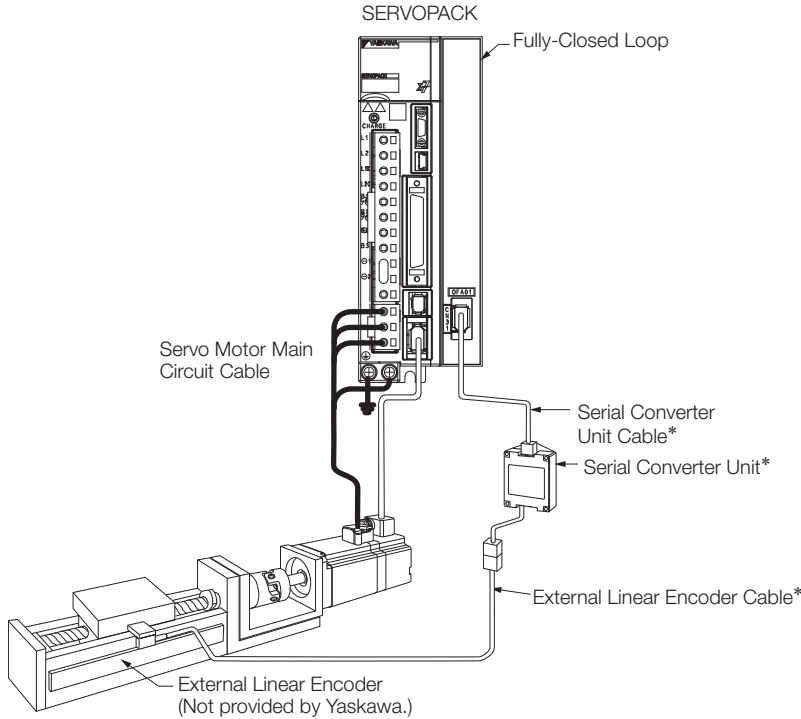

\* The connected devices and cables depend on the type of external Linear Encoder that is used.  
 Note: Refer to the following section for information on peripheral devices.  
 📖 *Peripheral Devices* (page 300)

## ◆ Connections to Linear Encoder from Heidenhain Corporation

### ■ Connections for a 1 Vp-p Analog Voltage Output Signal

You must make the connections through a Yaskawa Serial Converter Unit. The output signal will be multiplied by 8 bits (256 divisions) in the Serial Converter Unit.

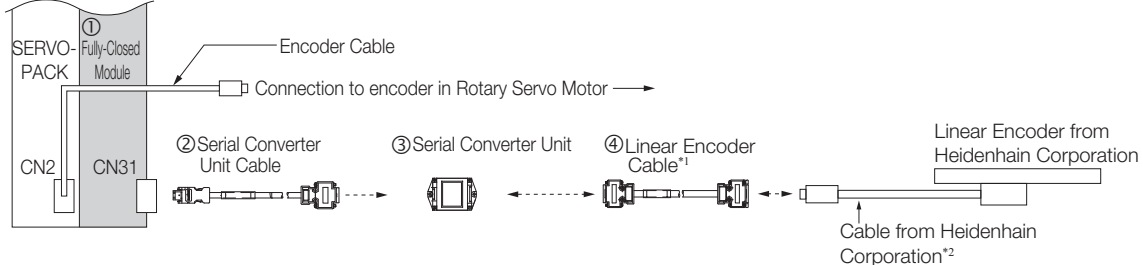

\*1. When using a JZDP-J00□□□□ Serial Converter Unit, do not use a Yaskawa Linear Encoder Cable that is longer than 3 m.  
 \*2. Contact Heidenhain Corporation for details on cables (analog 1 Vp-p output, D-sub 15-pin, male) from Heidenhain Corporation.

Additional SERVOPACK Options

## Additional SERVOPACK Options

### Feedback Option

No.	Item	Model	Reference
②	Serial Converter Unit Cable	JZSP-CLP70-□□E	page 298
③	Serial Converter Unit	JZDP-D003-000	page 301
④	Linear Encoder Cable	JZSP-CLL30-□□E	page 281

Note: 1. Refer to the following section for recommended Linear Encoders.

*Recommended Linear Encoders* (page M-11)

2. Refer to the following manual for the specifications of the Serial Converter Units.

*Σ-7-Series AC Servo Drive Peripheral Device Selection Manual* (Manual No.: SIEP S800001 32)

3. Refer to the following section for information on Servo Motor Main Circuit Cables and Encoder Cables.

*Cables and Peripheral Devices* (page 253)

### ■ Connections When Using a Yaskawa Serial Interface for the Output Signals

- LIC4100 Linear Encoder with EIB3391Y Interpolator

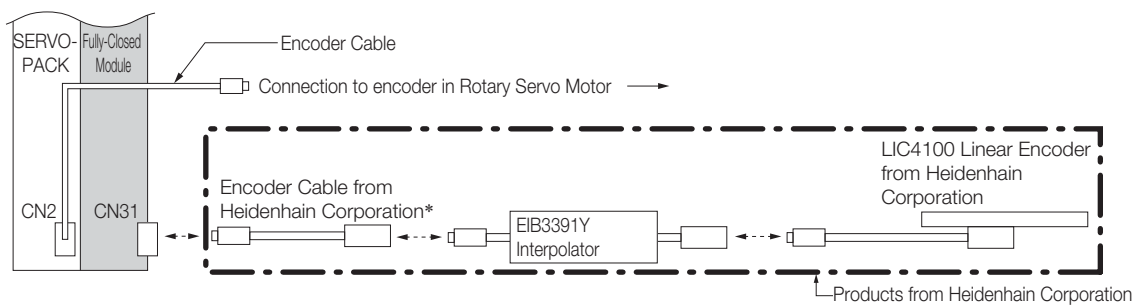

\* Use an Encoder Cable from Heidenhain Corporation. Contact Heidenhain Corporation for detailed Encoder Cable specifications.

## ◆ Connections to Linear Encoder from Renishaw Plc

### ■ Connections for a 1 Vp-p Analog Voltage Output Signal

You must make the connections through a Yaskawa Serial Converter Unit. The output signal will be multiplied by 8 bits (256 divisions) in the Serial Converter Unit.

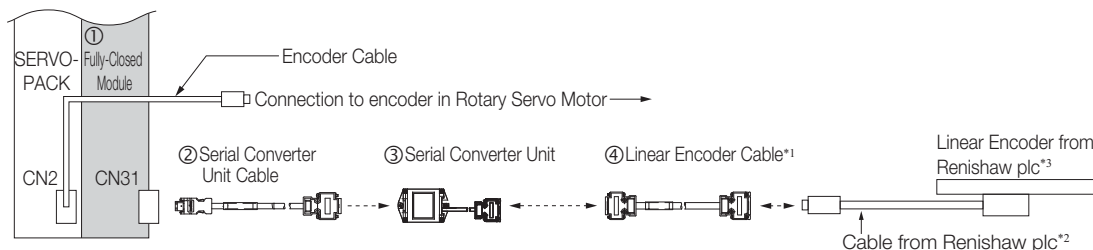

- \*1. When using a JZDP-J00□□□□ Serial Converter Unit, do not use a Yaskawa Linear Encoder Cable that is longer than 3 m.
- \*2. Contact Renishaw plc for details on cables (analog 1 Vp-p output, D-sub 15-pin, male) from Renishaw plc. However, the BID and DIR signals are not connected.
- \*3. If you use the origin signals with a Linear Encoder from Renishaw plc, the origin may sometimes be falsely detected. If that occurs, use the BID/DIR signal to output the origin signal only in one direction.

No.	Item	Model	Reference
②	Serial Converter Unit Cable	JZSP-CLP70-□□E	page 281
③	Serial Converter Unit	JZDP-D005-000	page 284
④	Linear Encoder Cable	JZSP-CLL00-□□E	page 281

Note: 1. Refer to the following section for recommended Linear Encoders.

- 📖 Recommended Linear Encoders (page M-11)
- 2. Refer to the following manual for the specifications of the Serial Converter Units.
  - 📖  $\Sigma$ -7-Series AC Servo Drive Peripheral Device Selection Manual (Manual No.: SIEP S800001 32)
- 3. Refer to the following section for information on Servo Motor Main Circuit Cables and Encoder Cables.
  - 📖 Cables and Peripheral Devices (page 253)

◆ **Connections to Linear Encoder from Magnescale Co., Ltd.**

■ **SL7□0 Linear Encoder and PL101-RY Sensor Head with Interpolator**

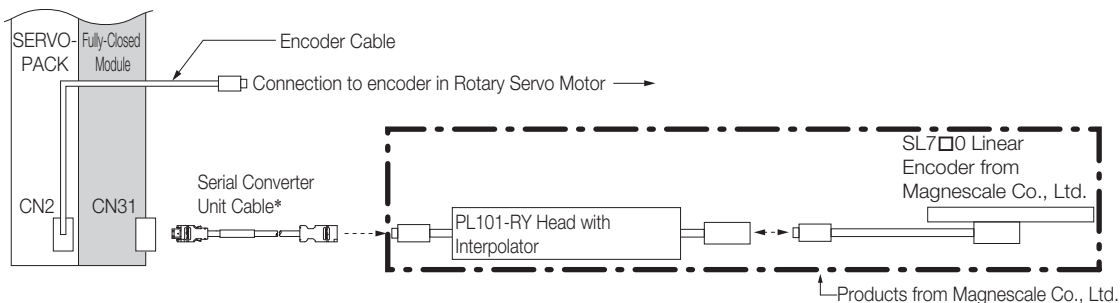

\* Refer to the following section for information on cables to connect Fully-Closed Loop and Linear Encoders.

☞ *Serial Converter Unit Cables (page 281)*

■ **SR-75, SR-77, SR-85, and SR-87 Linear Encoders**

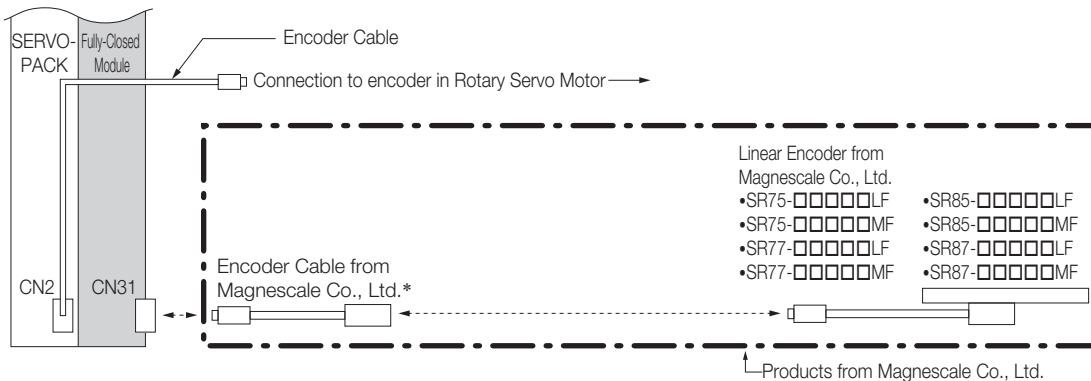

\* To connect the SERVOPACK and Linear Encoder, use a CH33-xx□□□ Cable from Magnescale Co., Ltd. (This Cable has connectors designed for use with Yaskawa products.)

■ **RU77-4096ADF/RU77-4096AFFT01 Absolute Rotary Encoders**

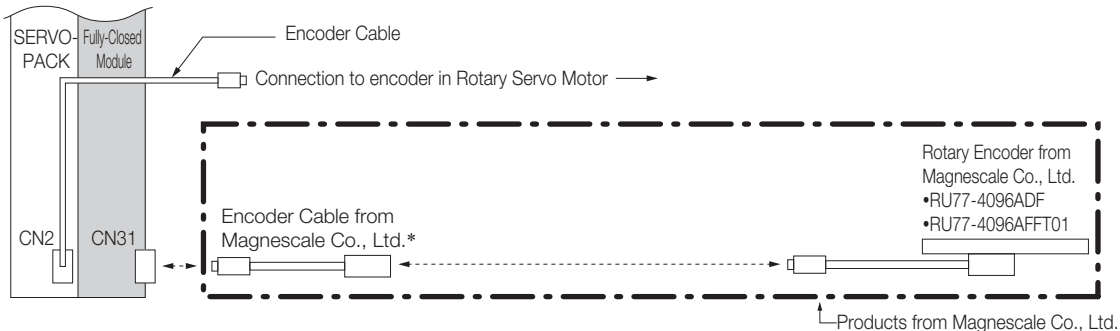

\* To connect the SERVOPACK and Rotary Encoder, use a CE28-Series Extension Cable for RU77 from Magnescale Co., Ltd.

Note: The RU77 is a single-turn absolute rotary encoder.

◆ Connections to Linear Encoders from Mitutoyo Corporation

■ ST78□A Linear Encoders

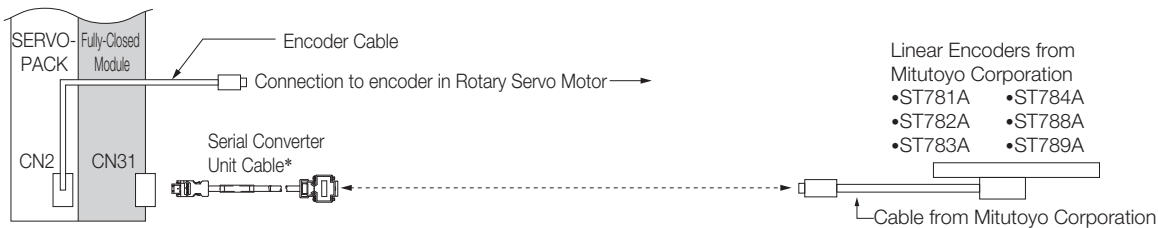

\* Refer to the following section for information on cables to connect Fully-Closed Loop and Linear Encoders.

👉 Serial Converter Unit Cables (page 281)

External Dimensions

Refer to pages 234 for the external dimensions of the individual SERVOPACKs.

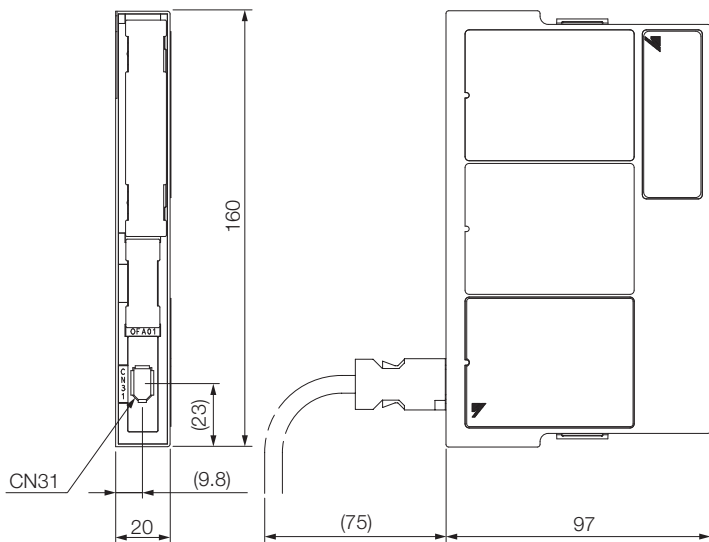

Unit: mm  
Approx. Mass: 0.1 kg

Connectors

Device Label	Model	Number of Pins	Manufacturer
CN31	3E106-0220KV	6	3M Japan Ltd.

Note: The above connectors or their equivalents are used for the Fully-Closed Option.

# Safety Option

## Advanced Safety Option

This advanced safety option implements safety functions that conform to EN ISO 13849-1 (the harmonized EU Machinery Directive) and are specified in the individual IEC 61800-5-2 standard. The advanced safety option for the SGD7S SERVOPACK is designed to optimize safety in a machine system according to industry needs.

## SERVOPACK Designations

### ◆ Purchasing a SERVOPACK with the advanced safety option

To order SERVOPACKs with the advanced safety option, use the following model numbers.



**1st+2nd+3rd digits** Maximum Applicable Motor Capacity

Voltage	Code	Specification
Three-phase, 200 VAC	R70 <sup>*2</sup>	0.05 kW
	R90 <sup>*2</sup>	0.1 kW
	1R6 <sup>*2</sup>	0.2 kW
	2R8 <sup>*2</sup>	0.4 kW
	3R8	0.5 kW
	5R5 <sup>*2</sup>	0.75 kW
	7R6	1.0 kW
	120	1.5 kW
	180	2.0 kW
	200	3.0 kW
	330	5.0 kW
	470	6.0 kW
	550	7.5 kW
590	11 kW	
780	15 kW	
Single-phase, 100 VAC	R70	0.05 kW
	R90	0.1 kW
	2R1	0.2 kW
	2R8	0.4 kW

**4th digit** Voltage

Code	Specification
A	200 VAC
F	100 VAC

**8th+9th+10th digits** Hardware Options Specification

Code	Specification	Applicable Models
000	Without options	All models

**5th+6th digits** Interface

Code	Specification
00	Analog voltage/pulse train reference
30	MECHATROLINK-III communications reference
A0	EtherCAT communications reference
M0	Sigma-7Siec (built-in single-axis control)

**11th+12th+13th digits** Option Module

Code	Specification
010	Safety Module

**7th digit** Design Revision Order

A: Global design revision

\*1. The model number of a SERVOPACK with an Option is not hyphenated after SGD7S.

\*2. You can use these models with either a single-phase or three-phase power supply input.



## Applicable Standards and Functions

### ◆ Applicable Safety Standards

Safety Standard	Applicable Standard	Applicable Products	
		SERVOPACK	SERVOPACK + Safety
Safety of Machinery	EN ISO13849-1:2008/AC:2009 IC 60204-1	✓	✓
Functional Safety	IEC 61508 Series IEC 62061 IEC 61800-5-2	✓	✓
EMC	IEC 61326-3-1	✓	✓

✓: Applicable

### ◆ Support for Functions Defined in IEC61800-5-2

Safety functions are implemented by using the hard wire base block (HWBB) in the SERVOPACK.

Safety Function	Description	Applicable Products	
		SERVOPACK	SERVOPACK + Safety
Safe BaseBlock Function (SBB function)	This safety function is equivalent to an STO function. (It shuts OFF the power supply from the SERVOPACK to the motor.)	✓	✓
Safe BaseBlock with Delay Function (SBB-D function)	This safety function is equivalent to an SS1 function. (It monitors the deceleration operation of the motor for the specified time and then shuts OFF the power supply from the SERVOPACK to the motor.)	–	✓
Safe Position Monitor with Delay Function (SPM-D function)	This safety function is equivalent to an SS2 function. (It monitors the deceleration operation of the motor for the specified time and then monitors the position after the motor stops.)	–	✓
Safely Limit Speed with Delay Function (SLS-D function)	This safety function is equivalent to an SLS function. (It monitors the deceleration operation of the motor for the specified time and then monitors the speed of the motor to confirm that it remains in the allowable range.)	–	✓

✓: Applicable

## Specifications

### ◆ Basic Specifications

Item		Specification	
Operating Conditions	Surrounding Air Temperature	0°C to +55°C	
	Storage Temperature	-20°C to +85°C	
	Surrounding Air Humidity	90% relative humidity max.	There must be no freezing or condensation.
	Storage Humidity	90% relative humidity max.	
	Vibration Resistance	4.9 m/s <sup>2</sup>	
	Shock Resistance	19.6 m/s <sup>2</sup>	
	Degree of Protection	IP10	<ul style="list-style-type: none"> <li>• Must be no corrosive or flammable gases.</li> <li>• Must be no exposure to water, oil, or chemicals.</li> <li>• Must be no dust, salts, or iron dust.</li> </ul>
	Pollution Degree	2	
	Altitude	1000 m max.	
	Others	Do not use the SERVOPACK in the following locations: Locations subject to static electricity noise, strong electromagnetic/magnetic fields, or radioactivity	

### ◆ Compliance with UL Standards, EU Directives, and Other Safety Standards (in Combination with SERVOPACK)

Item		Specification	
North American Safety Standards		UL61800-5-1 CSA C22.2 No.274	
European Directives	Machinery Directive (2006/42/EC)	EN ISO 13849-1: 2008/AC: 2009	
	EMC Directive (2004/108/EC)	EN 55011/A2 group 1, class A EN 61000-6-2 EN 61000-6-4 EN 61800-3	
	Low Voltage Directive (2006/95/EC)	EN 50178 EN 61800-5-1	
Safety Standards	Safety of Machinery	EN ISO 13849-1, IEC 60204-1	
	Functional Safety	IEC 61508-1 to IEC 61508-7, IEC 62061, and IEC 61800-5-2	
	EMC	IEC 61326-3-1	
Safety Function		IEC 61800-5-2	IEC 60204-1
		Safe Torque Off (STO)	Stop Category 0
		Safe Stop 1 (SS1)	Stop Category 1
		Safe Stop 2 (SS2)	Stop Category 2
		Safely Limited Speed (SLS)	
	Number of Blocks	2	
	Safety Function A	Input signals: 2 channels (redundant signals), output signals: 1 channel	
Safety Function B	Input signals: 2 channels (redundant signals), output signals: 1 channel		

Item	Specification
Safe Performance	
Safety Integrity Level	SIL2, SILCL2
Probability of Dangerous Failure per Hour	$PFH \geq 3.3 \times 10^{-7}$ [1/h]
Category	Cat3
Performance Level	PLd (Category 2)
Mean Time to Dangerous Failure of Each Channel	MTTFd: High
Average Diagnostic Coverage	DCave: Medium
Proof Test Interval	10 years

## External Dimensions

Refer to pages 234 for the external dimensions of the individual SERVOPACKs.

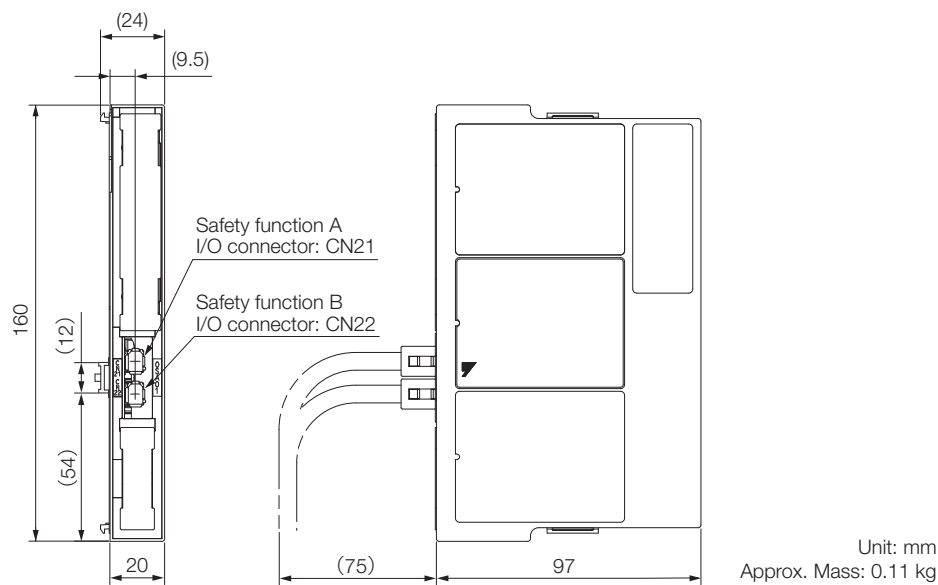

### Connectors

Device Label	Model	Number of Pins	Manufacturer
CN21	1981080-1	8	Tyco Electronics Japan G.K.
CN22	1981080-1	8	Tyco Electronics Japan G.K.

Note: 1. The above connectors or their equivalents are used for SERVOPACKs.

# Single-Axis Control Option

## Sigma-7Siec Option

The Sigma-7Siec option for Sigma-7 SERVOPACKs provides a compact, all-in-one servo/controller package with the following features:

- IEC61131-3 standard programming environment with PLCopen function blocks for motion control
- Self-tuning, anti-vibration, and other high performance, easy-to-implement servo control features
- Ethernet/IP, Modbus TCP/IP, and OPC server, which provide connectivity to PLCs, HMIs, SCADA, MES, and ERP
- Scalability with the multi-axis MP3000iec controller platform via the common programming environment, Motion-Works IEC
- Web server that allows for maintenance diagnostics and troubleshooting
- I/O features: 7 digital inputs, 4 digital outputs

## SERVOPACK Designations

### ◆ Purchasing a SERVOPACK with the Sigma-7Siec option

To order SERVOPACKs with the Sigma-7Siec option, use the following model numbers.



**1st+2nd+3rd digits** Maximum Applicable Motor Capacity

Voltage	Code	Specification
Three-phase, 200 VAC	R70 <sup>*2</sup>	0.05 kW
	R90 <sup>*2</sup>	0.1 kW
	1R6 <sup>*2</sup>	0.2 kW
	2R8 <sup>*2</sup>	0.4 kW
	3R8	0.5 kW
	5R5 <sup>*2</sup>	0.75 kW
	7R6	1.0 kW
	120	1.5 kW
	180	2.0 kW
	200	3.0 kW
	330	5.0 kW
	470	6.0 kW
	550	7.5 kW
	590	11 kW
780	15 kW	
Single-phase, 100 VAC	R70	0.05 kW
	R90	0.1 kW
	2R1	0.2 kW
	2R8	0.4 kW

**4th digit** Voltage

Code	Specification
A	200 VAC
F	100 VAC

**5th+6th digits** Interface

Code	Specification
M0	Sigma-7Siec (built-in single-axis control)

**7th digit** Design Revision Order

A: Global design revision

**8th+9th+10th digits** Hardware Options Specification

Code	Specification	Applicable Models
000	Without options	All models

**11th+12th+13th digits** FT/EX Specification

Code	Specification
F50	Application function for Sigma-7Siec

**14th+15th+16th digits** Option Module

Code	Specification
Blank	Standard
010 <sup>*1</sup>	Safety Module

\*1. The model number of a SERVOPACK with the Functional Safety option is not hyphenated after SGD7S.  
 \*2. You can use these models with either a single-phase or three-phase power supply input.

---

## Ratings and Specifications

Reference Sigma-7S EtherCAT Communications Reference SERVOPACKs ratings and specifications:

 [Ratings and Specifications \(page 299\)](#)

## External Dimensions

Reference Sigma-7S EtherCAT Communications Reference SERVOPACK external dimensions:

 [Σ-7S SERVOPACKs: MECHATROLINK-III and EtherCAT Type \(page 321\)](#)

## Cables and Peripheral Devices

Reference Sigma-7S EtherCAT Communications Reference SERVOPACK cables and peripheral devices:

 [SERVOPACK Cables \(page 356\)](#)

 [SERVOPACK Peripheral Devices \(page 364\)](#)

# 1.5-Axis Control Option

## MP2600iec Option

The MP2600iec option for Sigma-7 SERVOPACKs provides a compact, all-in-one servo/controller package with the following features:

- IEC61131-3 standard programming environment with PLCopen function blocks for motion control
- Self-tuning, anti-vibration, and other high performance, easy-to-implement servo control features
- Ethernet/IP, Modbus TCP/IP, and OPC server, which provide connectivity to PLCs, HMIs, SCADA, MES, and ERP
- Scalability with the multi-axis MP3000iec controller platform via the common programming environment, MotionWorks IEC
- Web server that allows for maintenance diagnostics and troubleshooting
- I/O features:
  - 15 digital inputs
  - 11 digital outputs
  - 1 analog input
  - 1 analog output
  - 1 external encoder input
  - 1 external encoder latch

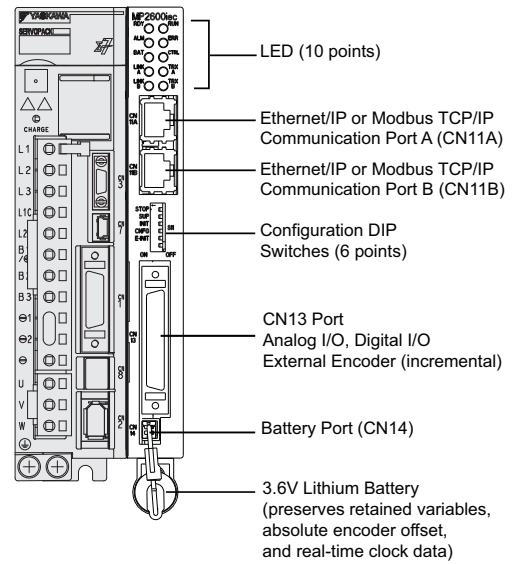

## SERVOPACK Designations

### ◆ Purchasing a SERVOPACK with the MP2600iec option

To order SERVOPACKs with the MP2600iec option, use the following model numbers.



1st+2nd+3rd digits Maximum Applicable Motor Capacity

Voltage	Code	Specification
Three-phase, 200 VAC	R70 <sup>*2</sup>	0.05 kW
	R90 <sup>*2</sup>	0.1 kW
	1R6 <sup>*2</sup>	0.2 kW
	2R8 <sup>*2</sup>	0.4 kW
	3R8	0.5 kW
	5R5 <sup>*2</sup>	0.75 kW
	7R6	1.0 kW
	120	1.5 kW
	180	2.0 kW
	200	3.0 kW
Single-phase, 100 VAC	330	5.0 kW
	470	6.0 kW
	550	7.5 kW
	590	11 kW
	780	15 kW
	R70	0.05 kW
	R90	0.1 kW
	2R1	0.2 kW
	2R8	0.4 kW

4th digit Voltage

Code	Specification
A	200 VAC
F	100 VAC

5th+6th digits Interface

Code	Specification
E0	Other control architecture type

7th digit Design Revision Order  
A: Global design revision

8th+9th+10th digits Hardware Options Specification

Code	Specification	Applicable Models
000	Without options	All models

11th+12th+13th digits FT/EX Specification

Code	Specification
300	MP2600iec single-axis control option

\*1. The model number of a SERVOPACK with an Option is not hyphenated after SGD7S.

\*2. You can use these models with either a single-phase or three-phase power supply input.

# External Dimensions

Reference Analog Voltage / Pulse Train Reference SERVOPACKs external dimensions

Σ-7S SERVOPACKs: Analog/Pulse and Command Option Type (page 318)

In order to determine the overall dimensions of the SERVOPACK & MP2600iec option card, add the dimensions of the option card pictured below to the base SERVOPACK dimensions.

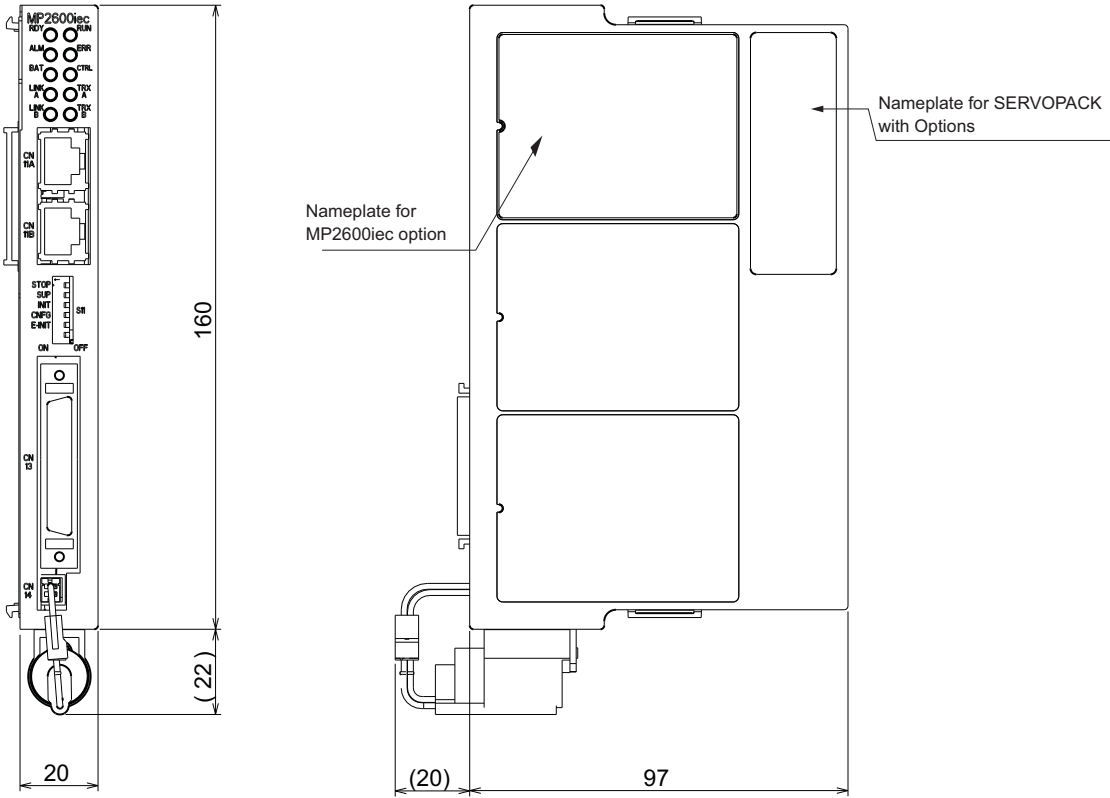

Dimensions in mm.

## Ratings and Specifications

### SERVOPACK Ratings

#### ◆ Three-Phase, 200 VAC

Model SGD7S-		R70A	R90A	1R6A	2R8A	3R8A	5R5A	7R6A	120A	180A	200A	330A	
Maximum Applicable Motor Capacity [kW]		0.05	0.1	0.2	0.4	0.5	0.75	1.0	1.5	2.0	3.0	5.0	
Continuous Output Current [Arms]		0.66	0.91	1.6	2.8	3.8	5.5	7.6	11.6	18.5	19.6	32.9	
Instantaneous Maximum Output Current [Arms]		2.1	3.2	5.9	9.3	11	16.9	17	28	42	56	84.0	
Main Circuit	Power Supply	200 VAC to 240 VAC, -15% to +10%, 50 Hz/60 Hz											
	Input Current [Arms]*	0.4	0.8	1.3	2.5	3.0	4.1	5.7	7.3	10	15	25	
Control	Power Supply	200 VAC to 240 VAC, -15% to +10%, 50 Hz/60 Hz											
	Input Current [Arms]*	0.2	0.2	0.2	0.2	0.2	0.2	0.2	0.2	0.25	0.25	0.3	
Power Supply Capacity [kVA]*		0.2	0.3	0.5	1.0	1.3	1.6	2.3	3.2	4.0	5.9	7.5	
Power Loss*	Main Circuit Power Loss [W]	5.0	7.0	11.9	22.5	28.5	38.9	49.2	72.6	104.2	114.2	226.6	
	Control Circuit Power Loss [W]	12	12	12	12	14	14	14	15	16	16	19	
	Built-in Regenerative Resistor Power Loss [W]	-	-	-	-	8	8	8	10	16	16	36	
	Total Power Loss [W]	17.0	19.0	23.9	34.5	50.5	60.9	71.2	97.6	136.2	146.2	281.6	
Regenerative Resistor	Built-In Regenerative Resistor	Resistance [W]	-	-	-	-	40	40	40	20	12	12	8
		Capacity [W]	-	-	-	-	40	40	40	60	60	60	180
	Minimum Allowable External Resistance [W]		40	40	40	40	40	40	40	20	12	12	8
Overvoltage Category		III											

\* This is the net value at the rated load.

Model SGD7S-		470A	550A	590A	780A	
Maximum Applicable Motor Capacity [kW]		6.0	7.5	11	15	
Continuous Output Current [Arms]		46.9	54.7	58.6	78.0	
Instantaneous Maximum Output Current [Arms]		110	130	140	170	
Main Circuit	Power Supply	200 VAC to 240 VAC, -15% to +10%, 50 Hz/60 Hz				
	Input Current [Arms]* <sup>1</sup>	29	37	54	73	
Control	Power Supply	200 VAC to 240 VAC, -15% to +10%, 50 Hz/60 Hz				
	Input Current [Arms]* <sup>1</sup>	0.3	0.3	0.4	0.4	
Power Supply Capacity [kVA]* <sup>1</sup>		10.7	14.6	21.7	29.6	
Power Loss* <sup>1</sup>	Main Circuit Power Loss [W]	271.7	326.9	365.3	501.4	
	Control Circuit Power Loss [W]	21	21	28	28	
	External Regenerative Resistor Power Loss [W]	180* <sup>2</sup>	350* <sup>3</sup>	350* <sup>3</sup>	350* <sup>3</sup>	
	Total Power Loss [W]	292.7	347.9	393.3	529.4	
Regenerative Resistor	External Regenerative Resistor	Resistance [Ω]	6.25* <sup>2</sup>	3.13* <sup>3</sup>	3.13* <sup>3</sup>	3.13* <sup>3</sup>
		Capacity [W]	880* <sup>2</sup>	1760* <sup>3</sup>	1760* <sup>3</sup>	1760* <sup>3</sup>
	Minimum Allowable External Resistance [Ω]		5.8	2.9	2.9	2.9
Overvoltage Category		III				

\*1. This is the net value at the rated load.

\*2. This value is for the optional JUSP-RA04-E Regenerative Resistor Unit.

\*3. This value is for the optional JUSP-RA05-E Regenerative Resistor Unit.



## ◆ Single-phase, 200 VAC

Model SGD7S-		R70A	R90A	1R6A	2R8A	5R5A	120A	
Maximum Applicable Motor Capacity [kW]		0.05	0.1	0.2	0.4	0.75	1.5	
Continuous Output Current [Arms]		0.66	0.91	1.6	2.8	5.5	11.6	
Instantaneous Maximum Output Current [Arms]		2.1	3.2	5.9	9.3	16.9	28	
Main Circuit	Power Supply	200 VAC to 240 VAC, -15% to +10%, 50 Hz/60 Hz						
	Input Current [Arms]*	0.8	1.6	2.4	5.0	8.7	16	
Control	Power Supply	200 VAC to 240 VAC, -15% to +10%, 50 Hz/60 Hz						
	Input Current [Arms]*	0.2	0.2	0.2	0.2	0.2	0.25	
Power Supply Capacity [kVA]*		0.2	0.3	0.6	1.2	1.9	4.0	
Power Loss*	Main Circuit Power Loss [W]	5.0	7.1	12.1	23.7	39.2	71.8	
	Control Circuit Power Loss [W]	12	12	12	12	14	16	
	Built-in Regenerative Resistor Power Loss [W]	–	–	–	–	8	16	
	Total Power Loss [W]	17.0	19.1	24.1	35.7	61.2	103.8	
Regenerative Resistor	Built-In Regen-erative Resistor	Resistance [ $\Omega$ ]	–	–	–	–	40	12
		Capacity [W]	–	–	–	–	40	60
	Minimum Allowable External Resistance [ $\Omega$ ]		40	40	40	40	40	12
Overvoltage Category		III						

\* This is the net value at the rated load.

## ◆ 270 VDC

Model SGD7S-		R70A	R90A	1R6A	2R8A	3R8A	5R5A	7R6A	120A
Maximum Applicable Motor Capacity [kW]		0.05	0.1	0.2	0.4	0.5	0.75	1.0	1.5
Continuous Output Current [Arms]		0.66	0.91	1.6	2.8	3.8	5.5	7.6	11.6
Instantaneous Maximum Output Current [Arms]		2.1	3.2	5.9	9.3	11.0	16.9	17.0	28.0
Main Circuit	Power Supply	270 VDC to 324 VDC, -15% to +10%							
	Input Current [Arms]* <sup>1</sup>	0.5	1.0	1.5	3.0	3.8	4.9	6.9	11
Control	Power Supply	270 VDC to 324 VDC, -15% to +10%							
	Input Current [Arms]* <sup>1</sup>	0.2	0.2	0.2	0.2	0.2	0.2	0.2	0.2 <sup>2</sup>
Power Supply Capacity [kVA]* <sup>1</sup>		0.2	0.3	0.6	1	1.4	1.6	2.3	3.2
Power Loss* <sup>1</sup>	Main Circuit Power Loss [W]	4.4	5.9	9.8	17.5	23.0	30.7	38.7	55.8
	Control Circuit Power Loss [W]	12	12	12	12	14	14	14	15
	Total Power Loss [W]	16.4	17.9	21.8	29.5	37.0	44.7	52.7	70.8
Overvoltage Category		III							

\*1. This is the net value at the rated load.

\*2. The value is 0.25 Arms for the SGD7S-120A00A008.

Model SGD7S-		180A	200A	330A	470A	550A	590A	780A
Maximum Applicable Motor Capacity [kW]		2.0	3.0	5.0	6.0	7.5	11.0	15.0
Continuous Output Current [Arms]		18.5	19.6	32.9	46.9	54.7	58.6	78.0
Instantaneous Maximum Output Current [Arms]		42.0	56.0	84.0	110	130	140	170
Main Circuit	Power Supply	270 VDC to 324 VDC, -15% to +10%						
	Input Current [Arms]*	14	20	34	36	48	68	92
Control	Power Supply	270 VDC to 324 VDC, -15% to +10%						
	Input Current [Arms]*	0.25	0.25	0.3	0.3	0.3	0.4	0.4
Power Supply Capacity [kVA]*		4.0	5.9	7.5	10.7	14.6	21.7	29.6
Power Loss*	Main Circuit Power Loss [W]	82.7	83.5	146.2	211.6	255.3	243.6	343.4
	Control Circuit Power Loss [W]	16	16	19	21	21	28	28
	Total Power Loss [W]	98.7	99.5	165.2	232.6	276.3	271.6	371.4
Overvoltage Category		III						

\* This is the net value at the rated load.

## Additional SERVOPACK Options

### 1.5-Axis Control Option

#### ◆ Single-phase, 100 VAC

Model SGD7S-		R70F	R90F	2R1F	2R8F
Maximum Applicable Motor Capacity [kW]		0.05	0.1	0.2	0.4
Continuous Output Current [Arms]		0.66	0.91	2.1	2.8
Instantaneous Maximum Output Current [Arms]		2.1	3.2	6.5	9.3
Main Circuit	Power Supply	100 VAC to 120 VAC, -15% to +10%, 50 Hz/60 Hz			
	Input Current [Arms]*	1.5	2.5	5	10
Control	Power Supply	100 VAC to 120 VAC, -15% to +10%, 50 Hz/60 Hz			
	Input Current [Arms]*	0.38	0.38	0.38	0.38
Power Supply Capacity [kVA]*		0.2	0.3	0.6	1.4
Power Loss*	Main Circuit Power Loss [W]	5.3	7.8	14.2	26.2
	Control Circuit Power Loss [W]	12	12	12	12
	Total Power Loss [W]	17.3	19.8	26.2	38.2
Regenerative Resistor	Minimum Allowable External Resistance [ $\Omega$ ]	40	40	40	40
Overvoltage Category		III			

\* This is the net value at the rated load.

# Specifications

Item		Specification	
Control Method		IGBT-based PWM control, sine wave current drive	
Feedback	With Rotary Servomotor	Serial encoder: 17 bits (absolute encoder) 20 bits or 24 bits (incremental encoder/absolute encoder)	
	With Linear Servomotor	<ul style="list-style-type: none"> <li>Absolute linear encoder (The signal resolution depends on the absolute linear encoder.)</li> <li>Incremental linear encoder (The signal resolution depends on the incremental linear encoder or Serial Converter Unit.)</li> </ul>	
Environmental Conditions	Surrounding Air Temperature	0°C to 45°C	
	Storage Temperature	-20°C to 85°C	
	Surrounding Air Humidity	90% relative humidity max. (with no freezing or condensation)	
	Storage Humidity	90% relative humidity max. (with no freezing or condensation)	
	Vibration Resistance	4.9 m/s <sup>2</sup>	
	Shock Resistance	19.6 m/s <sup>2</sup>	
	Degree of Protection	Class	SERVOPACK Model: SGD7S-
		IP20	R70A, R90A, 1R6A, 2R8A, 3R8A, 5R5A, 7R6A, 120A, R70F, R90F, 2R1F, 2R8F
		IP10	120AEOA008, 180A, 200A, 330A, 470A, 550A, 590A, 780A
	Pollution Degree	2 <ul style="list-style-type: none"> <li>Must be no corrosive or flammable gases.</li> <li>Must be no exposure to water, oil, or chemicals.</li> <li>Must be no dust, salts, or iron dust.</li> </ul>	
Altitude	1,000 m max.		
Others	Do not use the SERVOPACK in the following locations: Locations subject to static electricity noise, strong electromagnetic/magnetic fields, or radioactivity		
Applicable Standards		UL 61800-5-1 (E147823), CSA C22.2 No.274, EN ISO13849-1: 2015, EN 55011 group 1 class A, EN 61000-6-2, EN 61000-6-4, EN 61800-3 (Category C2, Second environment), EN 50178, EN 61800-5-1, IEC 60204-1, IEC 61508 series, IEC 62061, IEC 61800-5-2, and IEC 61326-3-1	
Mounting	Mounting	SERVOPACK Model: SGD7S-	
	Base-mounted	All Models	
	Rack-mounted	R70A, R90A, 1R6A, 2R8A, 3R8A, 5R5A, 7R6A, 120A, 180A, 200A, 330A, R70F, R90F, 2R1F, 2R8F	
	Duct-ventilated	470A, 550A, 590A, 780A	
Performance	Speed Control Range	1:5000 (At the rated torque, the lower limit of the speed control range must not cause the Servomotor to stop.)	
	Coefficient of Speed Fluctuation* <sup>1</sup>	±0.01% of rated speed max. (for a load fluctuation of 0% to 100%)	
		0% of rated speed max. (for a voltage fluctuation of ±10%)	
		±0.1% of rated speed max. (for a temperature fluctuation of 25°C ±25°C)	
Torque Control Precision (Repeatability)	±1%		
Soft Start Time Setting	0 s to 10 s (Can be set separately for acceleration and deceleration.)		
I/O Signals	Encoder Divided Pulse Output	Phase A, phase B, phase C: Line-driver output Number of divided output pulses: Any setting is allowed.	
	Overheat Protection Input	Number of input points: 1 Input voltage range: 0 V to +5 V	

Continued on next page.

## Additional SERVOPACK Options

### 1.5-Axis Control Option

Continued from previous page.

Item			Specification
I/O Signals	Sequence Input Signals	SERVOPACK	Fixed Input
			Allowable voltage range: 24 VDC ±20% Number of input points: 6
			Input method: Sink inputs or source inputs Input Signals: <ul style="list-style-type: none"> <li>• Alarm Reset (/ALM-RST)</li> <li>• Forward Drive Prohibited (P-OT)</li> <li>• Reverse Drive Prohibited (N-OT)</li> <li>• Origin Return Deceleration Switch (/DEC)</li> <li>• Registration (/RGRT)</li> <li>• Servo ON (/S-ON)</li> </ul> A signal can be allocated and the positive and negative logic can be changed.
	Allowable voltage range: 24 VDC ±20% Number of input points: 11 /MODE 0/1 (Mode Switch Input) signal		
Sequence Output Signals	SERVOPACK	Fixed Output	Allowable voltage range: 5 VDC to 30 VDC Number of output points: 1 Output signal: Servo Alarm (/ALM)
		Output Signals for Which Allocations Can Be Changed	Allowable voltage range: 5 VDC to 30 VDC Number of output points: 3. (A photocoupler output (isolated) is used.) Output Signals: <ul style="list-style-type: none"> <li>• Warning Output (/WARN)</li> <li>• Brake Output (/BK)</li> <li>• Servo Ready Output (/S-RDY)</li> <li>• Alarm Code Output (/ALO1, /ALO2, and /ALO3)</li> </ul> A signal can be allocated and the positive and negative logic can be changed.
Communications	RS-422A Communications (CN3)	Interfaces	Digital Operator (JUSP-OP05A-1-E) and personal computer (with SigmaWin+)
		1:N Communications	Up to N = 15 stations possible for RS-422A port
		Axis Address Setting	Set with parameters.
	USB Communications (CN7)	Interfaces	Interface Personal computer (with SigmaWin+)
Communications Standard		Conforms to USB2.0 standard (12 Mbps).	
Displays/Indicators	SERVOPACK		CHARGE and PWR indicators, and one-digit seven-segment display
Analog Monitor (CN5)			Number of points: 2 Output voltage range: ±10 VDC (effective linearity range: ±8 V) Resolution: 16 bits; Accuracy: ±20 mV (Typ) Maximum output current: ±10 mA Settling time (±1%): 1.2 ms (Typ)
Dynamic Brake (DB)			Activated when a servo alarm or overtravel (OT) occurs, or when the power supply to the main circuit or servo is OFF.
Regenerative Processing			Built-in (An external resistor must be connected to the SGD7S-470A to -780A.) Refer to the following section for details. <b> Built-In Regenerative Resistor (page 385)</b>
Overtravel (OT) Prevention			Stopping with a dynamic brake (DB), coasting to a stop, performing a hard stop, or performing a smooth stop (decelerating to a stop) for a CCW-OT (CCW Drive Prohibit Input) signal or CW-OT (CW Drive Prohibit Input) signal.
Protective Functions			Overcurrent, overvoltage, low voltage, overload, regeneration error, etc.
Utility Functions			Gain adjustment, alarm history, jogging, origin search, etc.
Safety Functions	Inputs		/HWBB1 and /HWBB2: Base block signals for Power Modules
	Output		EDM1: Monitors the status of built-in safety circuit (fixed output).
	Applicable Standards*2		ISO13849-1 PLe (Category 3), IEC61508 SIL3

\*1. The coefficient of speed fluctuation for load fluctuation is defined as follows:



$$\text{Coefficient of speed fluctuation} = \frac{\text{No-load motor speed} - \text{Total-load motor speed}}{\text{Rated motor speed}} \times 100\%$$

\*2. Always perform risk assessment for the system and confirm that the safety requirements are met.

---

## Cables and Peripheral Devices

Reference Sigma-7S Single-Axis Command Option Attachable SERVOPACK section for cables and peripheral devices:

-  [SERVOPACK Cables \(page 356\)](#)
-  [SERVOPACK Peripheral Devices \(page 364\)](#)

# Network Indexer Option

## SigmaLogic7 Compact Option

The SigmaLogic7 Compact option for Sigma-7 SERVOPACKs provides an intuitive, easy to implement solution for programming motion control using Rockwell PLCs. SigmaLogic7 Compact allows you to use Yaskawa's written and tested add-on instructions (AOIs) in your RSLogix5000 program with a ControlLogix or CompactLogix PLC. No other Yaskawa programming software is required:

- Use as many SigmaLogic instances as you have unused connections in your PLC
- Perform basic point-to-point moves, blended speed moves, homing, jogging, and gearing to an external encoder using direct commands or initiating moves through a configurable sequence table
- The LogixWorks™ software utility may be used to download sequence and configuration data

A full list of available add-on instructions is listed below. These are compatible with all CompactLogix and ControlLogix PLCs using RSLogix5000 software version 17 and above.

AOI Names	AOI Descriptions
MCFG_Yaskawa	Motion Axis Configuration
MSO_Yaskawa	Motion Axis Servo On
MSF_Yaskawa	Motion Axis Servo Off
MAS_Yaskawa	Motion Axis Stop
MAFR_Yaskawa	Motion Axis Fault Reset
MAM_Yaskawa	Motion Axis Move
MAJ_Yaskawa	Motion Axis Jog
MAHSP_Yaskawa	Motion Axis Home Set Position
MAH_Yaskawa	Motion Axis Homing
MAG_Yaskawa	Motion Axis "Gearing" Move
MAB_Yaskawa	Motion Axis "Blend" Move
MSQR_Yaskawa	Motion Axis Index Run Sequencer
MSQE_Yaskawa	Motion Axis Index Step Edit
MHSI_Yaskawa	Motion Axis High-Speed Index
MTRQ_Yaskawa	Motion Axis Torque Control
MCLK_Yaskawa	Motion Axis Set Clock
MPLS_Yaskawa	Motion Axis Programmable Limit Switch

Home Types
1 - Set Position Directly
2 - Home in Positive Direction to Hard Stop
3 - Home in Negative Direction to Hard Stop
4 - Home in Positive Direction to Limit w/o C-Pulse
5 - Home in Negative Direction to Limit w/o C-Pulse
6 - Home in Positive Direction to Limit w/ C-Pulse
7 - Home in Negative Direction to Limit w/ C-Pulse
8 - Home in Positive Direction to Input w/o C-Pulse
9 - Home in Negative Direction to Input w/o C-Pulse
10 - Home in Positive Direction to Input w/ C-Pulse
11 - Home in Negative Direction to Input w/ C-Pulse

Move Types
1 - Absolute Move
2 - Absolute Move with Registration
3 - Relative Move
4 - Relative Move with Registration
5 - Blended Move
6 - Jog
7 - Jog with Registration
8 - Gear On
9 - Gear Off
10 - Superimpose Move on Gear
11 - Torque Mode
12 - High Speed Index

## SERVOPACK Designations

### ◆ Purchasing a SERVOPACK with the SigmaLogic7 Compact option

To order SERVOPACKs with the SigmaLogic7 Compact option, use the following model numbers.

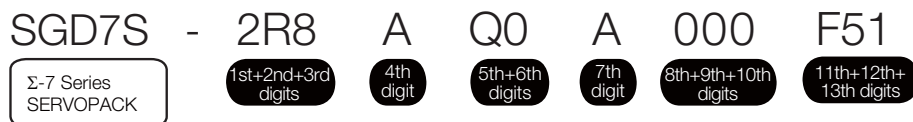

**1st+2nd+3rd digits** Maximum Applicable Motor Capacity

Voltage	Code	Specification
Three-phase, 200 VAC	R70*1	0.05 kW
	R90*1	0.1 kW
	1R6*1	0.2 kW
	2R8*1	0.4 kW
	3R8	0.5 kW
	5R5*1	0.75 kW
	7R6	1.0 kW
	120	1.5 kW
	180	2.0 kW
	200	3.0 kW
	330	5.0 kW
	470	6.0 kW
	550	7.5 kW
	590	11 kW
780	15 kW	
Single-phase, 100 VAC	R70	0.05 kW
	R90	0.1 kW
	2R1	0.2 kW
	2R8	0.4 kW

**4th digit** Voltage

Code	Specification
A	200 VAC
F	100 VAC

**8th+9th+10th digits** Hardware Options Specification

Code	Specification	Applicable Models
000	Without options	All models

**5th+6th digits** Interface

Code	Specification
Q0	SigmaLogic7 Compact (Ethernet/IP Indexer)

**11th+12th+13th digits** FT/EX Specification

Code	Specification
F51	Application function for SigmaLogic7 Compact

**7th digit** Design Revision Order

A: Global design revision

\*1. You can use these models with either a single-phase or three-phase power supply input.

## Ratings and Specifications

Reference Sigma-7S EtherCAT Communications Reference SERVOPACKs ratings and specifications:

[Ratings and Specifications \(page 299\)](#)

## External Dimensions

Reference Sigma-7S EtherCAT Communications Reference SERVOPACK external dimensions:

[Σ-7S SERVOPACKs: MECHATROLINK-III and EtherCAT Type \(page 321\)](#)

## Cables and Peripheral Devices

Reference Sigma-7S EtherCAT Communications Reference SERVOPACK cables and peripheral devices:

[SERVOPACK Cables \(page 356\)](#)

[SERVOPACK Peripheral Devices \(page 364\)](#)

# FT Specification Options

## FT19 Option - Less Deviation Control

The FT19 option for the Sigma-7 SERVOPACK provides built-in control with less deviation. There is almost no delay in motor operation for position references, which prevents path error caused by positioning response delays, and prevents interference between the machine and moving parts. FT19 is available with MECHATROLINK-III and Analog/Pulse style SERVOPACKs.

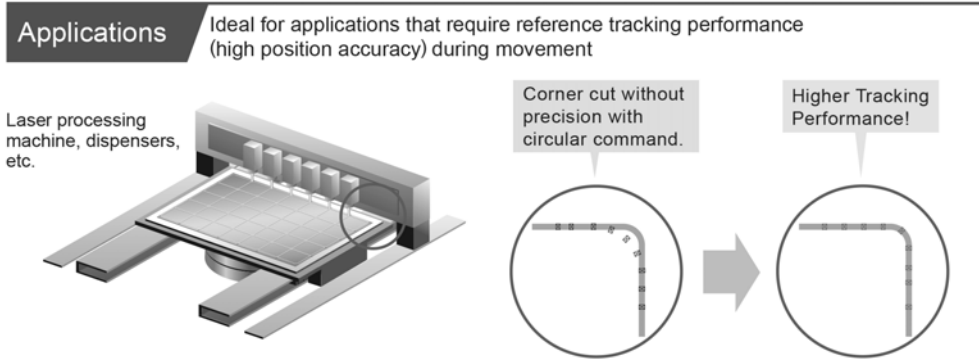



## SERVOPACK Designations

### ◆ Purchasing a SERVOPACK with the FT19 option

To order SERVOPACKs with the FT19 option, use the following model numbers.

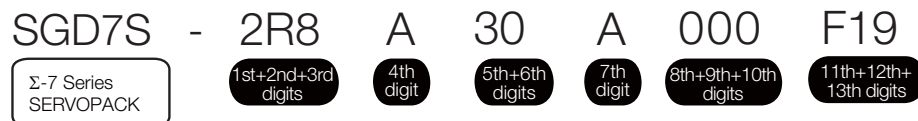

**1st+2nd+3rd digits** Maximum Applicable Motor Capacity

Voltage	Code	Specification
Three-phase, 200 VAC	R70 <sup>1)</sup>	0.05 kW
	R90 <sup>1)</sup>	0.1 kW
	1R6 <sup>1)</sup>	0.2 kW
	2R8 <sup>1)</sup>	0.4 kW
	3R8	0.5 kW
	5R5 <sup>1)</sup>	0.75 kW
	7R6	1.0 kW
	120	1.5 kW
	180	2.0 kW
	200	3.0 kW
	330	5.0 kW
	470	6.0 kW
	550	7.5 kW
	590	11 kW
780	15 kW	
Single-phase, 100 VAC	R70	0.05 kW
	R90	0.1 kW
	2R1	0.2 kW
	2R8	0.4 kW

**4th digit** Voltage

Code	Specification
A	200 VAC
F	100 VAC

**8th+9th+10th digits** Hardware Options Specification

Code	Specification	Applicable Models
000	Without options	All models

**5th+6th digits** Interface

Code	Specification
00	Analog voltage/pulse train reference
30	MECHATROLINK-III communications reference

**11th+12th+13th digits** FT/EX Specification

Code	Specification
F19	Application function for Less Deviation Control



**7th digit** Design Revision Order

A: Global design revision

\*1. You can use these models with either a single-phase or three-phase power supply input.

## Ratings and Specifications

Reference the Sigma-7S Ratings and Specifications of the appropriate SERVOPACK type:

-   $\Sigma$ -7S Single-axis Analog Voltage/Pulse Train Reference SERVOPACKs (page 278)
-   $\Sigma$ -7S Single-axis MECHATROLINK-III Communications Reference SERVOPACKs (page 288)
-   $\Sigma$ -7S Single-axis EtherCAT Communications Reference SERVOPACKs (page 298)



## External Dimensions

Reference the Sigma-7S External Dimensions of the appropriate SERVOPACK type:

-  SERVOPACK External Dimensions (page 316)

## Cables and Peripheral Devices

Reference Sigma-7S Cables and Peripheral Devices of the appropriate SERVOPACK type::

-  SERVOPACK Cables (page 356)
-  SERVOPACK Peripheral Devices (page 364)

# FT Specification Options

## FT79 Option - Built-in Indexer

The FT79 option for the Sigma-7 SERVOPACK provides built-in positioning with an indexer that lets you easily achieve motion control simply by entering positions, speeds, and other data for the operation pattern in the SigmaWin+ configuration tool. FT79 is available with Analog/Pulse style SERVOPACKS.

### Features High-Precision, High-Speed Positioning without a Motion Controller

The operation pattern is easily set by entering the positions, speeds, and other data in a program table. You can use the SigmaWin+ Engineering Tool to easily and efficiently set up and edit operation patterns.

- Convenient positioning functions are also provided: ZONE signal outputs, jog speed table, origin returns, and more.
- A start command is received from a host controller to start positioning.

#### Program Table Setting Example

PGMSTEP	POS	SPD	RDST	RSPD	ACC	DEC	EVENT	LOOP	NEXT
0	I+400000	2000	500000	1000	200	100	T5000	1	1
1	I+100000	1000	200000	2000	100	50	IT0	1	END
⋮	⋮	⋮	⋮	⋮	⋮	⋮	⋮	⋮	⋮
n	I+400000	2000	500000	1000	100	50	IT100	1	n+1
n+1	I+100000	1000	200000	2000	⋮	⋮	NT0	1	END
⋮	⋮	⋮	⋮	⋮	⋮	⋮	⋮	⋮	⋮
254	I+400000	2000	500000	1000	100	50	SEL3T200	1	127
255	I+100000	1000	200000	2000	100	50	DT0	1	END

#### POS/SPD/ACC/DEC commands

An operation pattern is set up by entering the target positions, positioning speeds, accelerations, and decelerations.

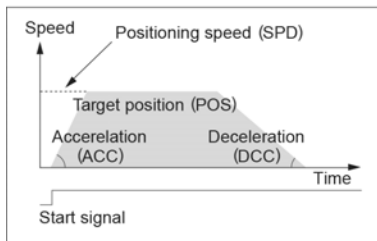

#### RDST/RSPD commands

The external signals can be used to control positioning (registration).

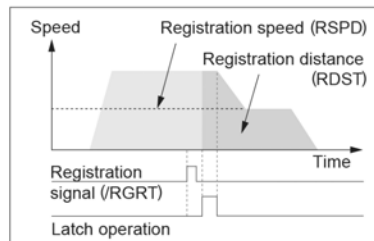

#### EVENT command

Conditions can be set to determine the completion of a program step.

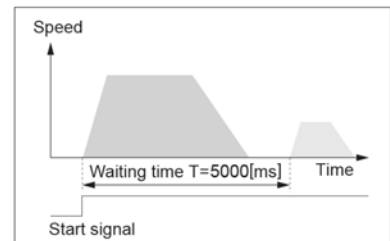

### Applications High-precision Positioning and Downsizing

Point-to-point positioning

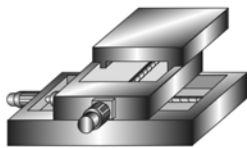

Fixed point positioning

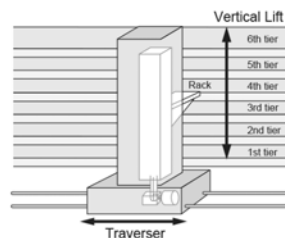

Station positioning (Indexing)

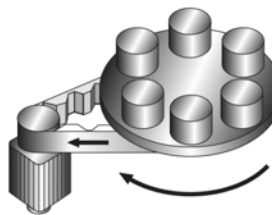

Feeding

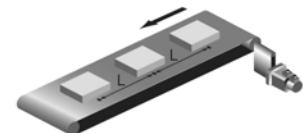

## SERVOPACK Designations

### ◆ Purchasing a SERVOPACK with the FT79 option

To order SERVOPACKs with the FT79 option, use the following model numbers.

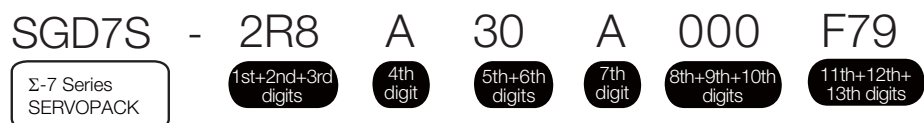

**1st+2nd+3rd digits** Maximum Applicable Motor Capacity

Voltage	Code	Specification
Three-phase, 200 VAC	R70*1	0.05 kW
	R90*1	0.1 kW
	1R6*1	0.2 kW
	2R8*1	0.4 kW
	3R8	0.5 kW
	5R5*1	0.75 kW
	7R6	1.0 kW
	120	1.5 kW
	180	2.0 kW
	200	3.0 kW
	330	5.0 kW
	470	6.0 kW
	550	7.5 kW
	590	11 kW
780	15 kW	
Single-phase, 100 VAC	R70	0.05 kW
	R90	0.1 kW
	2R1	0.2 kW
	2R8	0.4 kW

**4th digit** Voltage

Code	Specification
A	200 VAC
F	100 VAC

**8th+9th+10th digits** Hardware Options Specification

Code	Specification	Applicable Models
000	Without options	All models

**5th+6th digits** Interface

Code	Specification
00	Analog voltage/pulse train reference

**11th+12th+13th digits** FT/EX Specification

Code	Specification
F79	Application function for Simple Indexer



**7th digit** Design Revision Order

A: Global design revision

\*1. You can use these models with either a single-phase or three-phase power supply input.

## Ratings and Specifications

Reference the Sigma-7S Ratings and Specifications of the appropriate SERVOPACK type:

-  *Σ-7S Single-axis Analog Voltage/Pulse Train Reference SERVOPACKs* (page 278)
-  *Σ-7S Single-axis MECHATROLINK-III Communications Reference SERVOPACKs* (page 288)
-  *Σ-7S Single-axis EtherCAT Communications Reference SERVOPACKs* (page 298)



## External Dimensions

Reference the Sigma-7S External Dimensions of the appropriate SERVOPACK type:

-  *SERVOPACK External Dimensions* (page 316)

## Cables and Peripheral Devices



Reference Sigma-7S Cables and Peripheral Devices of the appropriate SERVOPACK type:

-  *SERVOPACK Cables* (page 356)
-  *SERVOPACK Peripheral Devices* (page 364)

# FT Specification Options

## FT81 Option - Harmonic Drive SHA Actuators

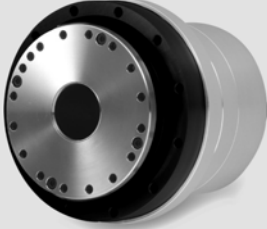
The FT81 option for the Sigma-7 SERVOPACK provides support for Harmonic Drive SHA Series Actuators. FT81 is available with MECHATROLINK-III and EtherCAT style SERVOPACKs.

SHA-SG	SHA-CG
<p data-bbox="375 516 743 541">SHA-SG featuring compact-shape</p> <p data-bbox="321 573 435 598">Compact</p>  <p data-bbox="310 800 813 936">The SHA Servo Actuator combines precision Harmonic Drive® gearing with a flat AC servo motor. It has a unique compact shape and Hollow Shaft actuator design. Five sizes are available: 25, 32, 40, 58, and 65. Sizes 25 and 32 can also be combined with HarmonicPlanetary® gearing.</p>	<p data-bbox="889 516 1377 541">SHA-CG with improved output flange runout accuracy</p> <p data-bbox="889 562 1003 615">High Accuracy</p> <p data-bbox="889 657 1003 709">Even Ratios</p>  <p data-bbox="878 821 1382 909">The SHA-CG delivers high precision with improved positioning accuracy and surface runout. These actuators are ideal for high precision rotary applications such as indexing tables. Three sizes are available: 25, 32, and 40.</p>

## SERVOPACK Designations

### ◆ Purchasing a SERVOPACK with the FT81 option

To order SERVOPACKs with the FT81 option, use the following model numbers.

Σ-7 Series SERVOPACK
 - 
 1st+2nd+3rd digits
A
30
A
000
F81

**1st+2nd+3rd digits** Maximum Applicable Motor Capacity

Voltage	Code	Specification
Three-phase, 200 VAC	R70*1	0.05 kW
	R90*1	0.1 kW
	1R6*1	0.2 kW
	2R8*1	0.4 kW
	3R8	0.5 kW
	5R5*1	0.75 kW
	7R6	1.0 kW
	120	1.5 kW
	180	2.0 kW
	200	3.0 kW
	330	5.0 kW
	470	6.0 kW
	550	7.5 kW
	590	11 kW
780	15 kW	
Single-phase, 100 VAC	R70	0.05 kW
	R90	0.1 kW
	2R1	0.2 kW
	2R8	0.4 kW

**4th digit** Voltage

Code	Specification
A	200 VAC
F	100 VAC

**5th+6th digits** Interface

Code	Specification
00	Analog voltage/pulse train reference
30	MECHATROLINK-III communications reference
A0	EtherCAT communications reference

**7th digit** Design Revision Order

A: Global design revision

**8th+9th+10th digits** Hardware Options Specification

Code	Specification	Applicable Models
000	Without options	All models

**11th+12th+13th digits** FT/EX Specification

Code	Specification
F81	Application function for connection to Harmonic Drive SHA series actuators

\*1. You can use these models with either a single-phase or three-phase power supply input.

## Ratings and Specifications

Reference the Sigma-7S Ratings and Specifications of the appropriate SERVOPACK type:

- [Σ-7S Single-axis Analog Voltage/Pulse Train Reference SERVOPACKs \(page 278\)](#)
- [Σ-7S Single-axis MECHATROLINK-III Communications Reference SERVOPACKs \(page 288\)](#)
- [Σ-7S Single-axis EtherCAT Communications Reference SERVOPACKs \(page 298\)](#)

## External Dimensions

Reference the Sigma-7S External Dimensions of the appropriate SERVOPACK type:

- [SERVOPACK External Dimensions \(page 316\)](#)

## Cables and Peripheral Devices

Reference Sigma-7S Cables and Peripheral Devices of the appropriate SERVOPACK type::

- [SERVOPACK Cables \(page 356\)](#)
- [SERVOPACK Peripheral Devices \(page 364\)](#)

For more information on Harmonic Drive SHA Series Actuators:

Visit: <http://www.harmonicdrive.net/products/rotary-actuators/hollow-shaft-actuators/sha-sg>

**Additional SERVOPACK Options**

---

FT Specification Options

# SERVOPACK Cables/ Peripherals

---

SERVOPACK Cables .....356

SERVOPACK Peripheral Devices .....364

# SERVOPACK Cables

## System Configurations

■  $\Sigma$ -7S Single-axis Analog Voltage/Pulse Train Reference SERVOPACKS

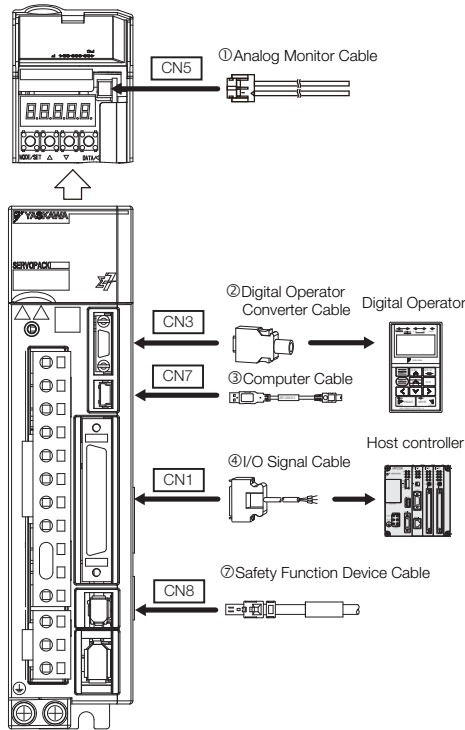

■  $\Sigma$ -7S Single-axis MECHATROLINK-III Communications Reference SERVOPACKS

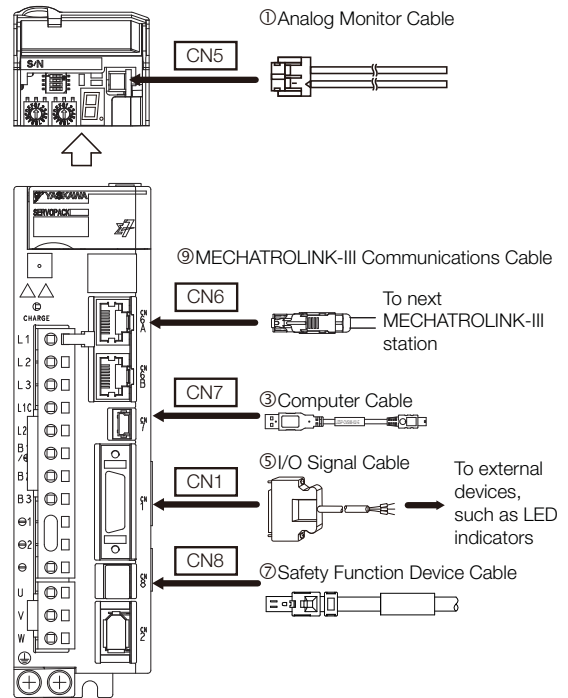

■  $\Sigma$ -7S Single-axis EtherCAT Comm. Reference and Sigma-7Siec SERVOPACKS

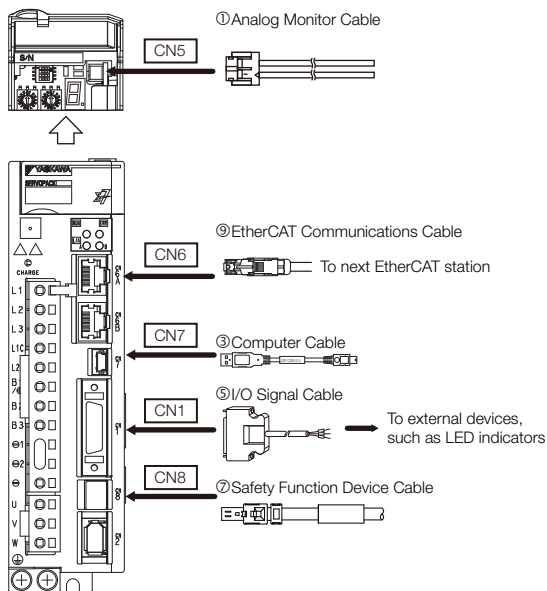

■  $\Sigma$ -7W Two-axis MECHATROLINK-III Communications Reference SERVOPACKS

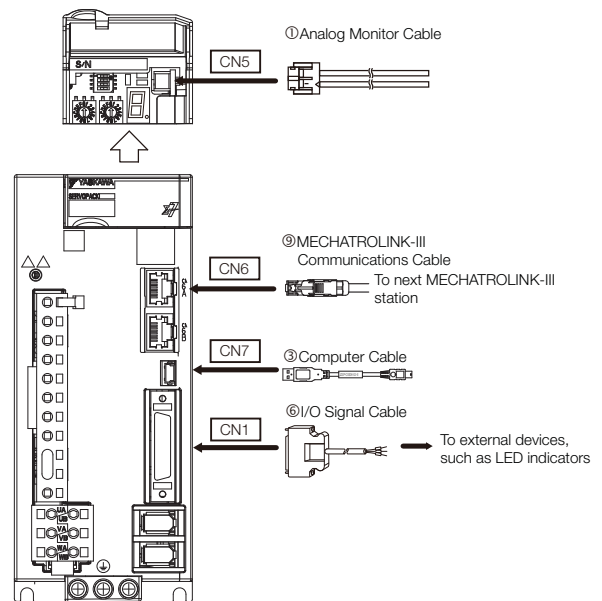



■  $\Sigma$ -7S Single-axis Command Option Attachable-Type SERVOPACKs

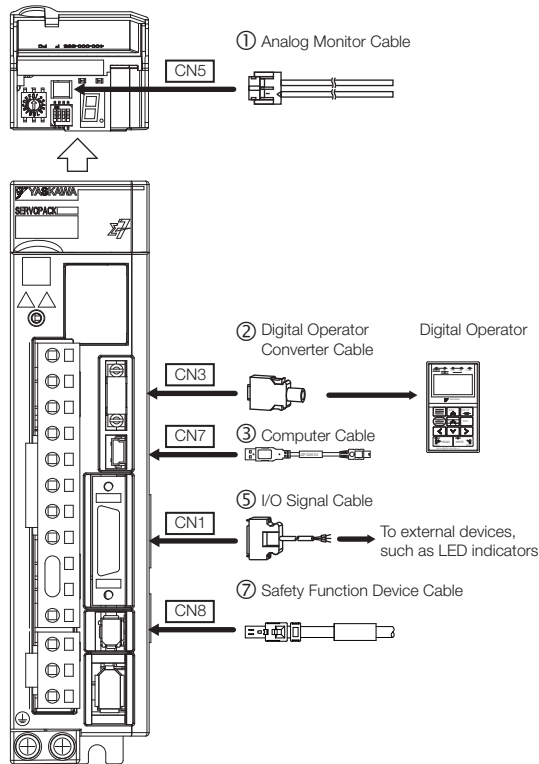

■ Command Option Module: Safety Module

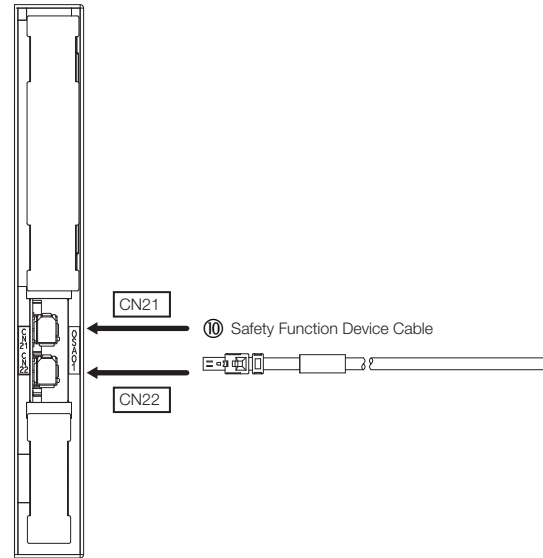

■ Command Option Module: MP2600 Module

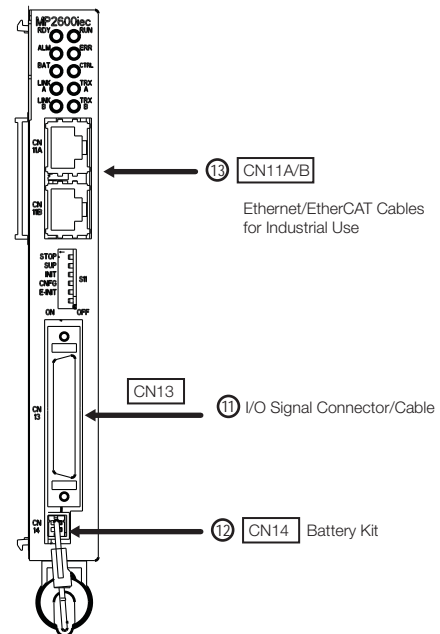

## Selection Table









Important

1. Use the cable specified by Yaskawa for the Computer Cable. Operation may not be dependable with any other cable.
2. Use the cable specified by Yaskawa for the MECHATROLINK Communications Cables. Operation may not be dependable due to low noise resistance with any other cable.

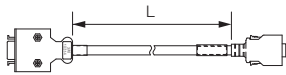
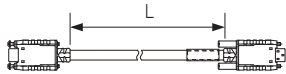
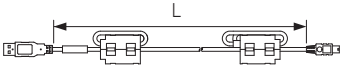

Note: Refer to the following manual for the following information.

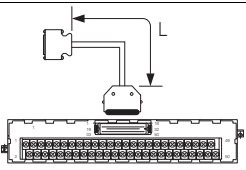
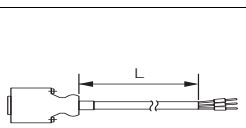
- Cable dimensional drawings and cable connection specifications
- Order numbers and specifications of individual connectors for cables

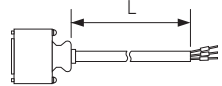
 *Σ-7-Series AC Servo Drive Peripheral Device Selection Manual* (Manual No.: SIEP S800001 32)

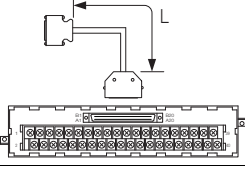
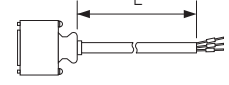
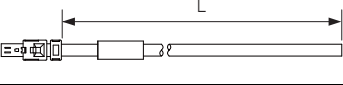
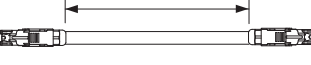
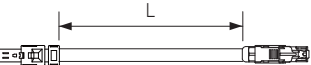
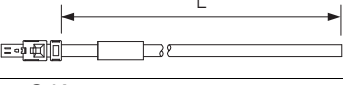
Code	Name		Length (L)	Order Number	Appearance/Spec
①	Analog Monitor Cable		1 m	JZSP-CA01-E	
②	Digital Operator Converter Cable		0.3 m	JZSP-CVS05-A3-E*1	
				JZSP-CVS07-A3-E*2	
③	Computer Cable		2.5 m	JZSP-CVS06-02-E	
④	I/O Signal Cables	Soldered Connector Kit		JZSP-CSI9-1-E	
		Connector-Terminal Block Converter Unit (with cable)	0.5 m	JUSP-TA50PG-E	
			1 m	JUSP-TA50PG-1-E	
			2 m	JUSP-TA50PG-2-E	
		Cable with Loose Wires at One End (loose wires on peripheral device end)	1 m	JZSP-CSI01-1-E	
			2 m	JZSP-CSI01-2-E	
3 m	JZSP-CSI01-3-E				
⑤	I/O Signal Cables	Soldered Connector Kit		JZSP-CSI9-2-E	
		Connector-Terminal Converter Unit	0.5 m	SBK-U-VBA-A5(B)	Terminal block & 0.5m connection cable
			1 m	SBK-U-VBA-01(B)	
			3 m	SBK-U-VBA-03(B)	
		Cable with Loose Wires at One End (loose wires on peripheral device end)	1 m	JZSP-CSI02-1-E	
			2 m	JZSP-CSI02-2-E	
3 m	JZSP-CSI02-3-E				

Code	Name	Length (L)	Order Number	Appearance/Spec	
⑥	I/O Signal Cables	Soldered Connector Kit		DP9420007-E	
		Connector-Terminal Block Converter Unit (with cable)	0.5 m	JUSP-TA36P-E	
			1 m	JUSP-TA36P-1-E	
			2 m	JUSP-TA36P-2-E	
		Cable with Loose Wires at One End (peripheral device end)	1 m	JZSP-CSI03-1-E	
			2 m	JZSP-CSI03-2-E	
3 m	JZSP-CSI03-3-E				
⑦	Safety Function Device Cable	Cables with Connectors* <sup>3</sup>	0.45 m	JZSP-CVH03-A45(A)-E	
			1 m	JZSP-CVH03-01(A)-E	
			3 m	JZSP-CVH03-03(A)-E	
		Connector Kit* <sup>4</sup>		Contact Tyco Electronics Japan G.K. Name: Industrial Mini I/O D-shape Type 1 Plug Connector Kit Model number: 2013595-1	
⑨	EtherCAT or MECHATROLINK-III Communications Cables	Cables with RJ45 Connectors on Both Ends	0.2 m	CM3RRM0-00P2-E	
			0.5 m	CM3RRM0-00P5-E	
			1 m	JZSP-CM3RRM0-01-E	
			3 m	JZSP-CM3RRM0-03-E	
			5 m	JZSP-CM3RRM0-05-E	
			10 m	JZSP-CM3RRM0-10-E	
			20 m	JZSP-CM3RR00-20-E	
			30 m	JZSP-CM3RR00-30-E	
			40 m	JZSP-CM3RR01-40-E	
			50 m	JZSP-CM3RR01-50-E	
		Cables with RJ45 Connector on One End and IMI Connector on Other End	0.2 m	CM3RMM0-00P2-E	
			0.5 m	CM3RMM0-00P5-E	
			1 m	JZSP-CM3RMM0-01-E	
			3 m	JZSP-CM3RMM0-03-E	
			5 m	JZSP-CM3RMM0-05-E	
			10 m	JZSP-CM3RMM0-10-E	
			20 m	JZSP-CM3RM00-20-E	
			30 m	JZSP-CM3RM00-30-E	
			40 m	JZSP-CM3RM01-40-E	
			50 m	JZSP-CM3RM01-50-E	
⑩	Safety Function Device Cables	Cables with Connectors* <sup>3</sup>	0.45 m	JZSP-CVH03-A45(A)-E	
			1 m	JZSP-CVH03-01(A)-E	
			3 m	JZSP-CVH03-03(A)-E	
		Connector Kit* <sup>4</sup>		Contact Tyco Electronics Japan G.K. Name: Industrial Mini I/O D-shape Type 1 Plug Connector Kit Model number: 2013595-1	

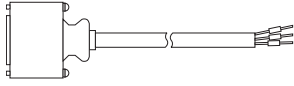
Code	Name	Length (L)	Order Number	Appearance/Spec	
⑪	MP2600iec Cables for I/O Signals (CN13)	Connector Kit		JZSP-CSI9-1E 	
		Connector Terminal Converter Unit	0.5 m	CBK-U-MP2B-A5	
			1 m	CBK-U-MP2B-01	
			3 m	CBK-U-MP2B-03	
		Flying Lead Cable	0.5 m	CFC-U-MP2B-A5	
			1 m	CFC-U-MP2B-01	
3 m	CFC-U-MP2B-03				
⑫	MP2600iec CN14 Battery Kit		SGDV-OZC02A	3.6 V Lithium battery, cable with connector, and mounting bracket for MP2600iec	
⑬	MP2600iec Cables for I/O Signals (CN13)		Category: CAT5e Shield specifications: S/UTP or S/STP Cable length: 50 m maximum		

- \*1. This Converter Cable is required to use the Σ-III-series Digital Operator (JUSP-OP05A) for Σ-7-series SERVOPACKs.
- \*2. If you use a MECHATROLINK-III Communications Reference SERVOPACK, this Converter Cable is required to prevent the cable from disconnecting from the Digital Operator.
- \*3. When using safety functions, connect this Cable to the safety function devices.  
When not using safety functions, connect the enclosed Safety Jumper Connector to the SERVOPACK.
- \*4. Use the Connector Kit when you make cables yourself.

### ◆ Connector Kit for CN13 (MP2600iec)

Use the following connector and cable to assemble the cable. The CN13 connector kit includes one case and one connector.

Connector Kit Model	Case		Connector	
	Model	Qty	Model	Qty
JZSP-CSI9-1-E	10350-52Z0-008*	1 set	10150-3000PE* (Soldered)	1

Dimensional Drawings of Case

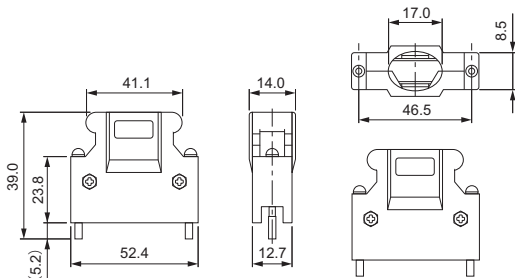

Dimensional Drawings of Connector

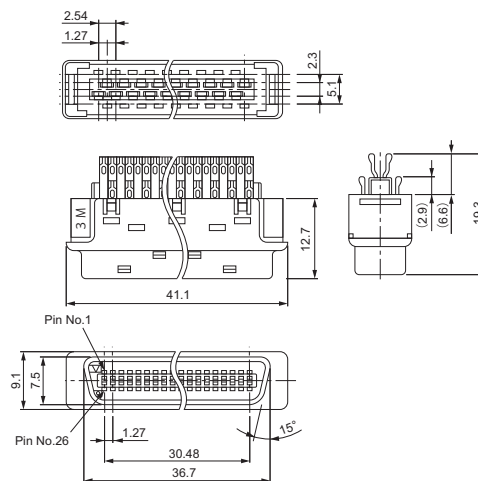

Cable Size

Item	Specifications
Cable	Use twisted pair or twisted pair shielded wire
Applicable Wires	AWG 24, 26, 28, 30
Cable Finished Diameter	16 dia. max

◆ Connector Terminal Converter Unit for CN13 (MP2600iec)

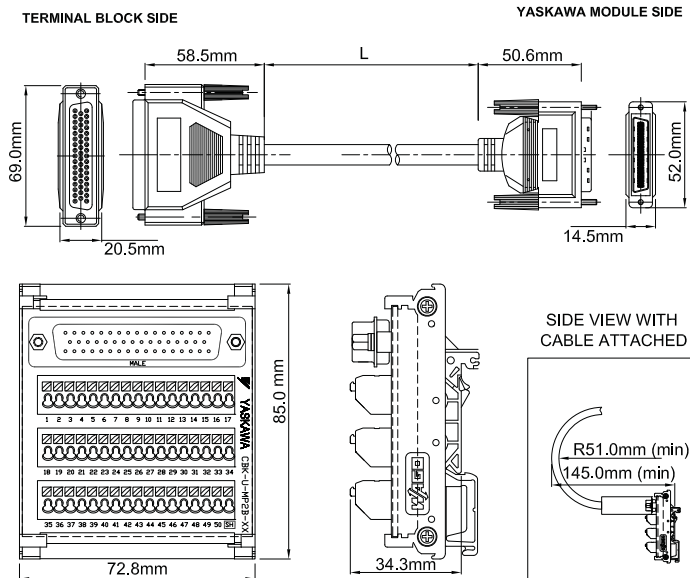

ITEM#	L = LENGTH (mm)
CBK-U-MP2B-A5	500 +/- 38.1
CBK-U-MP2B-01	1000 +/- 38.1
CBK-U-MP2B-03	3000 +/- 38.1

CABLE SPECIFICATION (mm)	
OUTER DIAMETER	8.5 +/- 0.1mm
BENDING RADIUS	6 x O.D. MINIMUM 15 x O.D. FOR LONG TERM RELIABILITY

CBK-U-MP2B-XX Function Chart for MP2600iec

Pin No.	Signal Name	I/O	Function
1	AO	O	Analog output
2	AI	I	Analog input
3	-	-	-
4	PA+	I	Phase A pulse (+)
5	PA-	I	Phase A pulse (-)
6	GND	P	Encoder input ground
7	BAT+	P	Controller SRAM Battery (+)
8	-	-	-
9	PILC5V	I	Phase-C latch pulse (-) for 5VDC input
10	PILC24V	I	Phase-C latch pulse (-) for 24VDC input
11	DO 00-	O	Digital output 0 (-)
12	DO 02-	O	Digital output 2 (-)
13	DICOM	I	Digital input common
14	DI 00	I	Digital input 0
15	DI 02	I	Digital input 2
16	DI 04	I	Digital input 4
17	DI 06	I	Digital input 6
18	DO 04-	O	Digital output 4 (-)
19	DO 06-	O	Digital output 6 (-)
20	-	-	-
21	DO 00+	O	Digital output 0 (+)
22	DO 02+	O	Digital output 2 (+)
23	DO 04+	O	Digital output 4 (+)
24	DO 06+	O	Digital output 6 (+)
25	-	-	-
26	AO GND	O	Analog output ground
27	AI GND	I	Analog input ground
28	-	-	-
29	PB+	I	Phase B pulse (+)
30	PB-	I	Phase B pulse (-)
31	GND	P	Encoder input ground
32	BAT-	P	Controller SRAM Battery (-)
33	-	-	-
34	PILC12V	I	Phase-C latch pulse (-) for 12VDC input
35	PIL	I	Phase-C latch pulse (+)
36	DO 01-	O	Digital output 1 (-)
37	DO 03-	O	Digital output 3 (-)
38	DICOM	I	Digital input common
39	DI 01	I	Digital input 1 - shared with pulse latch input
40	DI 03	I	Digital input 3
41	DI 05	I	Digital input 5
42	DI 07	I	Digital input 7
43	DO 05-	O	Digital output 5 (-)
44	DO 07-	O	Digital output 7 (-)
45	-	-	-
46	DO 01+	O	Digital output 1 (+)
47	DO 03+	O	Digital output 3 (+)
48	DO 05+	O	Digital output 5 (+)
49	DO 07+	O	Digital output 7 (+) - shared w/ position agreement COIN signal
50	-	-	-

I = Input, O = Output, P = Power

◆ Flying Lead Cable for CN13 (MP2600iec)

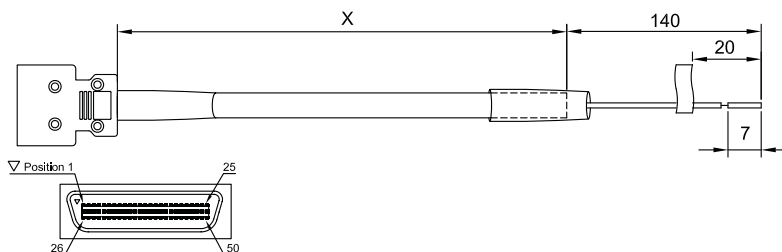

ITEM NUMBER	X = LENGTH (mm)
CFC-U-MP2B-A5	500
CFC-U-MP2B-01	1000
CFC-U-MP2B-03	3000

CABLE SPECIFICATION (mm)	
OUTER DIAMETER	8.1
BENDING RADIUS	12 O.D.

CFC-U-MP2B-XX Function Chart for MP2600iec

Pin No.	Color (Solid/Band)	Signal Name		Function
1	BLK/RED	AO	O	Analog output
2	BLK/WHT	AI	I	Analog input
3	RED/GRN	-	-	-
4	BLK/BLU	PA+	I	Phase A pulse (+)
5	BLU/BLK	PA-	I	Phase A pulse (-)
6	RED/BLU	GND	P	Encoder input ground
7	RED/WHT	BAT+	P	Controller SRAM Battery (+)
8	BLK/GRN	-	-	-
9	BLK/YEL	PILC5V	I	Phase-C latch pulse (-) for 5VDC input
10	BLK/ORG	PILC24V	I	Phase-C latch pulse (-) for 24VDC input
11	RED/YEL	DO 00-	O	Digital output 0 (-)
12	RED/BRN	DO 02-	O	Digital output 2 (-)
13	RED/ORG	DICOM	I	Digital input common
14	GRN/WHT	DI 00	I	Digital input 0
15	GRN/BLU	DI 02	I	Digital input 2
16	GRN/YEL	DI 04	I	Digital input 4
17	GRN/BRN	DI 06	I	Digital input 6
18	GRN/ORG	DO 04-	O	Digital output 4 (-)
19	WHT/BLU	DO 06-	O	Digital output 6 (-)
20	WHT/YEL	-	-	-
21	YEL/RED	DO 00+	O	Digital output 0 (+)
22	BRN/RED	DO 02+	O	Digital output 2 (+)
23	ORG/GRN	DO 04+	O	Digital output 4 (+)
24	BLU/WHT	DO 06+	O	Digital output 6 (+)
25	WHT/BRN	-	-	-
26	RED/BLK	AO GND	O	Analog output ground
27	WHT/BLK	AI GND	I	Analog input ground
28	GRN/RED	-	-	-
29	BLK/BRN	PB+	I	Phase B pulse (+)
30	BRN/BLK	PB-	I	Phase B pulse (-)
31	BLU/RED	GND	P	Encoder input ground
32	WHT/RED	BAT-	P	Controller SRAM Battery (-)
33	GRN/BLK	-	-	-
34	ORG/BLK	PILC12V	I	Phase-C latch pulse (-) for 12VDC input
35	YEL/BLK	PIL	I	Phase-C latch pulse (+)
36	WHT/ORG	DO 01-	O	Digital output 1 (-)
37	BLU/YEL	DO 03-	O	Digital output 3 (-)
38	ORG/RED	DICOM	I	Digital input common
39	WHT/GRN	DI 01	I	Digital input 1 - shared with pulse latch input
40	BLU/GRN	DI 03	I	Digital input 3
41	YEL/GRN	DI 05	I	Digital input 5
42	BRN/GRN	DI 07	I	Digital input 7
43	BLU/BRN	DO 05-	O	Digital output 5 (-)
44	BLU/ORG	DO 07-	O	Digital output 7 (-)
45	YEL/WHT	-	-	-
46	ORG/WHT	DO 01+	O	Digital output 1 (+)
47	YEL/BLU	DO 03+	O	Digital output 3 (+)
48	BRN/BLU	DO 05+	O	Digital output 5 (+)
49	ORG/BLU	DO 07+	O	Digital output 7 (+) - shared w/ position agreement COIN signal
50	BRN/WHT	-	-	-

I = Input, O = Output, P = Power



# SERVOPACK Peripheral Devices

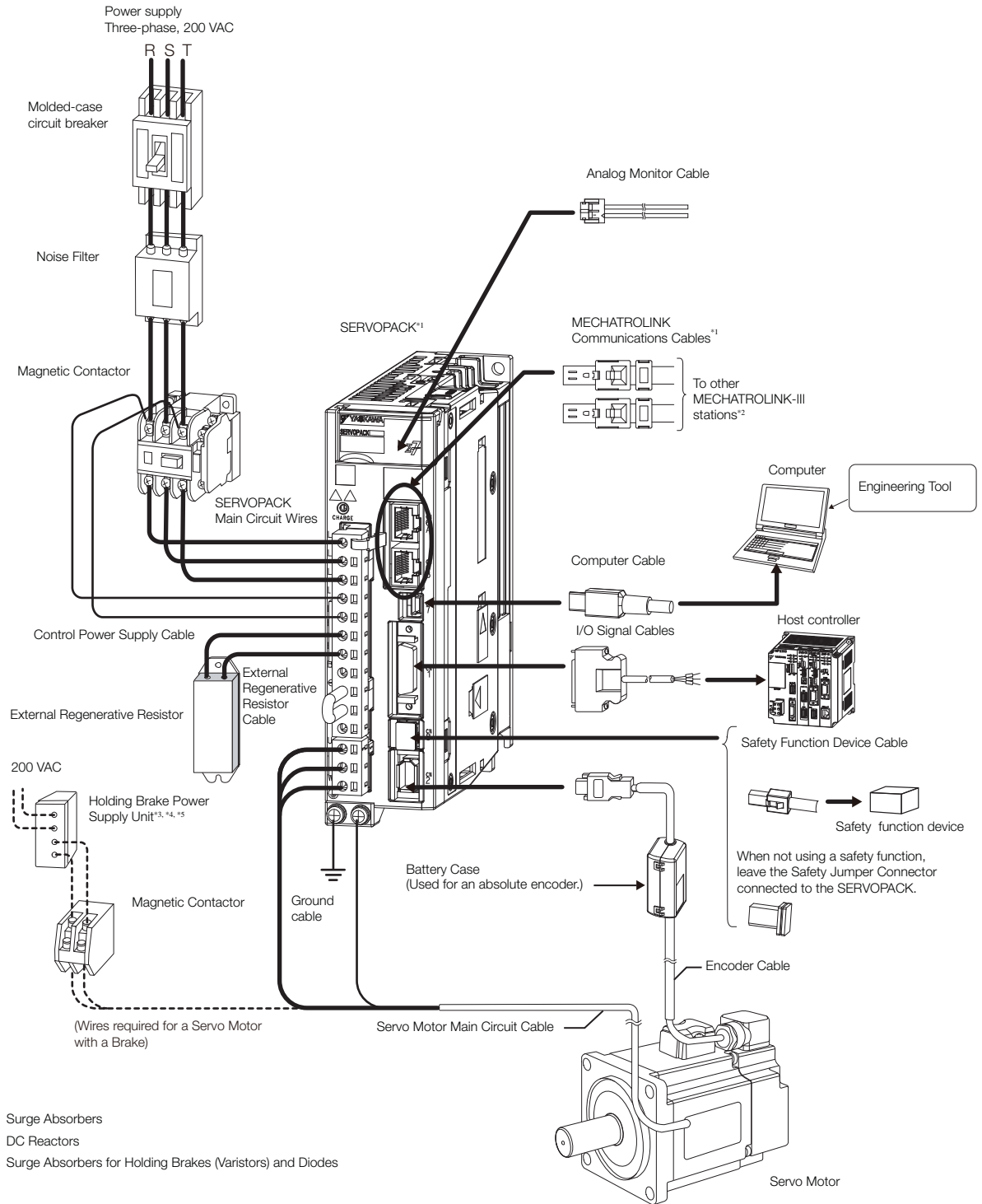



- 
- \*1. The peripheral devices are described using a MECHATROLINK-III Communications Reference SERVOPACK as an example. The shapes of the connectors may be different for other interfaces.
  - \*2. The connected devices depend on the interface.  
For MECHATROLINK-II communications references: Other MECHATROLINK-II stations  
For analog voltage/pulse train references: There is no CN6 connector.
  - \*3. A Holding Brake Power Supply Unit is required to use a Servo Motor with a Holding Brake. Holding Brake Power Supply Units for 24 VDC are not provided by Yaskawa. Obtain these from other manufacturers.  
Never connect Holding Brake Power Supply Units with different output voltages to a SERVOPACK. Overcurrent may result in burning in the brake.
  - \*4. If you use a Servo Motor with a Holding Brake, select a brake relay according to the power supply voltage and current of the brake. Yaskawa does not recommend any particular brake relays. Select an appropriate brake relay using the selection method of the brake relay manufacturer.
  - \*5. The power supply for the holding brake is not provided by Yaskawa. Select a power supply based on the holding brake specifications. If you use a 24-V brake, install a separate power supply for the 24-VDC power supply from other power supplies, such as the one for the I/O signals of the CN1 connector. If the power supply is shared, the I/O signals may malfunction.

## Peripheral Device Selection Table

Main Circuit Power Supply	SERVOPACK			Noise Filter*1	DC Reactor*2	Magnetic Contactor	Surge Absorber	Digital Operator
	Maximum Applicable Motor Capacity [kW]	Model SGD7S-	Model SGD7W-					
Three-phase, 200 VAC	0.05	R70A	–	HF3010C-SZC	X5061	SC-03	LT-C32G801WS	JUSP-OP05A-1-E
	0.1	R90A	–					
	0.2	1R6A	–					
	0.4	2R8A	1R6A					
	0.5	3R8A	–					
	0.75	5R5A	2R8A	HF3020C-SZC	X5060	SC-4-1		
	1.0	7R6A	–					
	1.5	120A	5R5A					
	2.0	180A	7R6A	HF3030C-SZC	X5059	SC-5-1		
	3.0	200A	–					
	5.0	330A	–					
	6.0	470A	–					
	7.5	550A	–					
	11	590A	–					
15	780A	–						
Single-phase, 200 VAC	0.05	R70A	–	HF2010A-UPF	X5071	SC-03		
	0.1	R90A	–					
	0.2	1R6A	–					
	0.4	2R8A	1R6A	X5070				
	0.75	5R5A	2R8A	HF2020A-UPF-2BB	X5079	SC-4-1		
							X5069	
1.5	–	5R5A	HF2030A-UPF-2BB	X5078	SC-5-1			

Device	Inquiries
Noise Filters	Yaskawa Controls Co., Ltd.
Surge Absorbers	
DC Reactors	
Magnetic Contactors	Fuji Electric FA Components & Systems Co., Ltd.

\*1. Some Noise Filters have large leakage currents. The grounding conditions also affect the size of the leakage current. If necessary, select an appropriate leakage detector or leakage breaker taking into account the grounding conditions and the leakage current from the Noise Filter.

\*2. The last digit of an RoHS-compliant serial number is R. Consult with Yaskawa Controls Co., Ltd. for RoHS-compliant reactors.

Note: 1. Consult the manufacturer for details on peripheral devices.

2. Refer to the following section for information on Digital Operator Converter Cables.

 Selection Table (page 358)

3. Refer to the following manual for the following information.

- Dimensional drawings, ratings, and specifications of peripheral devices

 *Σ-7-Series AC Servo Drive Peripheral Device Selection Manual* (Manual No.: SIEP S800001 32)

## Molded-case Circuit Breakers and Fuses

### Using an AC Power Supply

Use a molded-case circuit breaker and fuse to protect the power supply line. They protect the power line by shutting OFF the circuit when overcurrent is detected. Select these devices based on the information in the following tables.

Note: The following tables also provide the net values of the current capacity and inrush current. Select a fuse and a molded-case circuit breaker that meet the following conditions.

- Main circuit and control circuit: No breaking at three times the current value given in the table for 5 s.
- Inrush current: No breaking at the current value given in the table for 20 ms.

#### ◆ Σ-7S SERVOPACKs

Main Circuit Power Supply	Maximum Applicable Motor Capacity [kW]	SERVOPACK Model: SGD7S-	Power Supply Capacity per SERVOPACK [kVA]*	Current Capacity		Inrush Current	
				Main Circuit [Arms]*	Control Power Supply [Arms]	Main Circuit [A0-p]	Control Power Supply [A0-p]
Three-phase, 200 VAC	0.05	R70A	0.2	0.4	0.2	34	34
	0.1	R90A	0.3	0.8			
	0.2	1R6A	0.5	1.3			
	0.4	2R8A	1.0	2.5			
	0.5	3R8A	1.3	3.0			
	0.75	5R5A	1.6	4.1			
	1.0	7R6A	2.3	5.7			
	1.5	120A	3.2	7.3	0.25		
	2.0	180A	4.0	10			
	3.0	200A	5.9	15	0.3	68	
	5.0	330A	7.5	25			
	6.0	470A	10.7	29			
	7.5	550A	14.6	37	0.4	114	
11	590A	21.7	54				
15	780A	29.6	73				
Single-phase, 200 VAC	0.05	R70A	0.2	0.8	0.2	34	
	0.1	R90A	0.3	1.6			
	0.2	1R6A	0.6	2.4			
	0.4	2R8A	1.2	5.0			
	0.75	5R5A	1.9	8.7			

\* This is the net value at the rated load.

**◆ Σ-7W SERVOPACKs**

Main Circuit Power Supply	Maximum Applicable Motor Capacity per Axis [kW]	SERVOPACK Model: SGD7W-	Power Supply Capacity per SERVOPACK [kVA] <sup>*1</sup>	Current Capacity		Inrush Current	
				Main Circuit [Arms] <sup>*1</sup>	Control Power Supply [Arms]	Main Circuit [A0-p]	Control Power Supply [A0-p]
Three-phase, 200 VAC	0.2	1R6A	1.0	2.5	0.25	34	34
	0.4	2R8A	1.9	4.7			
	0.75	5R5A	3.2	7.8			
	1.0	7R6A	4.5	11			
Single-phase, 200 VAC	0.2	1R6A	1.3	5.5			
	0.4	2R8A	2.4	11			
	0.75	5R5A <sup>*2</sup>	2.7	12			

\*1. This is the net value at the rated load.

\*2. If you use the SGD7W-5R5A with a single-phase 200-VAC power supply input, derate the load ratio to 65%. An example is given below.

If the load ratio of the first axis is 90%, use a load ratio of 40% for the second axis so that average load ratio for both axes is 65% ((90% + 40%)/2 = 65%).

## Using a DC Power Supply

This section gives the power supply specifications for using a DC power supply input. Use the Fuses given in the following tables to protect the power supply line and SERVOPACK. They protect the power line by shutting OFF the circuit when overcurrent is detected.

Note: The following tables provide the net values of the current capacity and inrush current.

**◆ Σ-7S SERVOPACKs**

Main Circuit Power Supply	SERVOPACK Model: SGD7S-	Power Supply Capacity per SERVOPACK [kVA] <sup>*1</sup>	Current Capacity		Inrush Current		External Fuse		
			Main Circuit [Arms] <sup>*1</sup>	Control Power Supply [Arms]	Main Circuit [A0-p]	Control Power Supply [A0-p]	Order Number <sup>*2</sup>	Current Rating [A]	Voltage Rating [Vdc]
270 VDC	R70A	0.2	0.5	0.2	34	34	3,5URGJ17/16UL	16	400
	R90A	0.3	1.0						
	1R6A	0.5	1.5						
	2R8A	1.0	3.0						
	3R8A	1.3	3.8	0.2					
	5R5A	1.6	4.9						
	7R6A	2.3	6.9						
	120A	3.2	11	0.2	0.25				
	180A	4.0	14						
	200A	5.9	20						
	330A	7.5	34	0.3	68 <sup>*3</sup> (5 Ω external)	34	3,5URGJ17/40UL	40	
	470A	10.7	36						
	550A	14.6	48						
590A	21.7	68							
780A	29.6	92	0.4	114 <sup>*3</sup> (3 Ω external)	34	3,5URGJ17/63UL	63		
							3,5URGJ17/100UL	100	
							3,5URGJ23/160UL	160	
							3,5URGJ23/200UL	200	

\*1. This is the net value at the rated load.

\*2. These Fuses are manufactured by MERSEN Japan.

\*3. If you use a DC power supply input with any of the following SERVOPACKs, externally connect an inrush current limiting circuit and use the power ON and OFF sequences recommended by Yaskawa: SGD7S-330A, -470A, -550A, -590A, or -780A. There is a risk of equipment damage. For information on the power ON and OFF sequences, refer to the product manual for the type of references used by your SERVOPACK.

◆ Σ-7W SERVOPACKs

Main Circuit Power Supply	SERVOPACK Model: SGD7W-	Power Supply Capacity per SERVOPACK [kVA] <sup>*1</sup>	Current Capacity		Inrush Current		External Fuse		
			Main Circuit [Arms] <sup>*1</sup>	Control Power Supply [Arms]	Main Circuit [A0-p]	Control Power Supply [A0-p]	Order Number <sup>*2</sup>	Current Rating [A]	Voltage Rating [Vdc]
270 VDC	1R6A	1	3.0	0.25	34	34	3,5URGJ17/40UL	40	400
	2R8A	1.9	5.8						
	5R5A	3.2	9.7				3,5URGJ17/63UL	63	
	7R6A	4.5	14						

\*1. This is the net value at the rated load.

\*2. These Fuses are manufactured by MERSEN Japan.

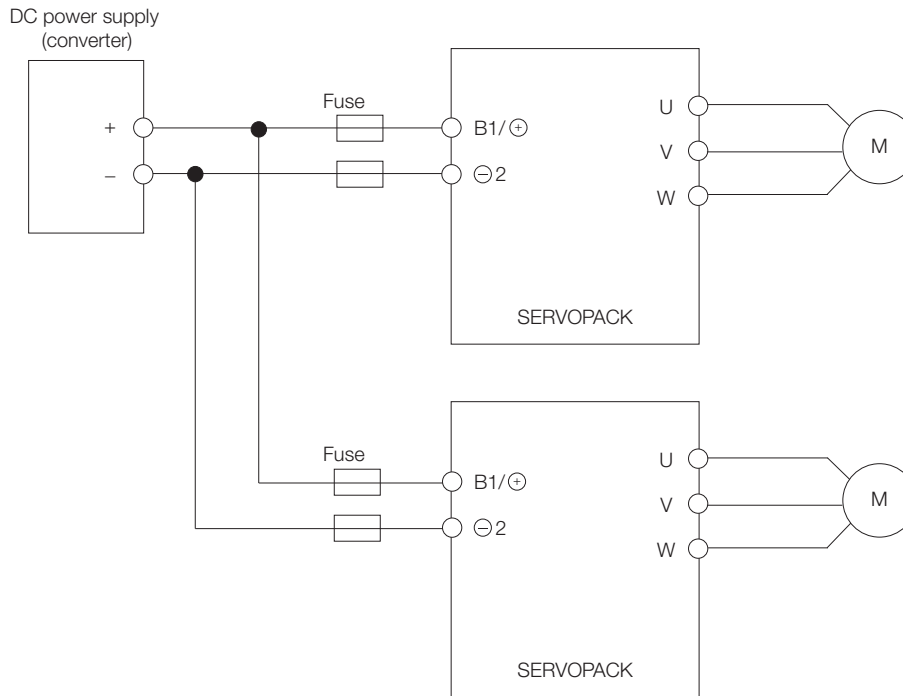

Note: If you connect more than one SERVOPACK to the same DC power supply, connect Fuses for each SERVOPACK.

## SERVOPACK Main Circuit Wires

This section describes the main circuit wires for SERVOPACKs.



Important

These specifications are based on IEC/EN 61800-5-1, UL 61800-5-1, and CSA C22.2 No.274.

1. To comply with UL standards, use UL-compliant wires.
2. Use copper wires with a rated temperature of 75° or higher.
3. Use copper wires with a rated withstand voltage of 300 V or higher.

Note: To use 600-V heat-resistant polyvinyl chloride-insulated wire (HIV), use the following table as reference for the applicable wires.

- The specified wire sizes are for three bundled leads when the rated current is applied with a surrounding air temperature of 40°C.
- Select the wires according to the surrounding air temperature.

### Three-phase, 200-VAC Wires for $\Sigma$ -7S SERVOPACKs

SERVOPACK Model: SGD7S-	Terminals		Wire Size	Screw Size	Tightening Torque [N·m]
R70A	Main Circuit Power Supply Cable	L1, L2, L3	AWG16 (1.25 mm <sup>2</sup> )	-	-
	Servo Motor Main Circuit Cable*	U, V, W			
	Control Power Supply Cable	L1C, L2C			
	External Regenerative Resistor Cable	B1/⊕, B2			
	Ground cable	⊕	AWG14 (2.0 mm <sup>2</sup> ) min.	M4	1.2 to 1.4
R90A	Main Circuit Power Supply Cable	L1, L2, L3	AWG16 (1.25 mm <sup>2</sup> )	-	-
	Servo Motor Main Circuit Cable*	U, V, W			
	Control Power Supply Cable	L1C, L2C			
	External Regenerative Resistor Cable	B1/⊕, B2			
	Ground cable	⊕	AWG14 (2.0 mm <sup>2</sup> ) min.	M4	1.2 to 1.4
1R6A	Main Circuit Power Supply Cable	L1, L2, L3	AWG16 (1.25 mm <sup>2</sup> )	-	-
	Servo Motor Main Circuit Cable*	U, V, W			
	Control Power Supply Cable	L1C, L2C			
	External Regenerative Resistor Cable	B1/⊕, B2			
	Ground cable	⊕	AWG14 (2.0 mm <sup>2</sup> ) min.	M4	1.2 to 1.4
2R8A	Main Circuit Power Supply Cable	L1, L2, L3	AWG16 (1.25 mm <sup>2</sup> )	-	-
	Servo Motor Main Circuit Cable*	U, V, W			
	Control Power Supply Cable	L1C, L2C			
	External Regenerative Resistor Cable	B1/⊕, B2			
	Ground cable	⊕	AWG14 (2.0 mm <sup>2</sup> ) min.	M4	1.2 to 1.4

Continued on next page.

Continued from previous page.

SERVOPACK Model: SGD7S-	Terminals		Wire Size	Screw Size	Tightening Torque [N·m]		
3R8A	Main Circuit Power Supply Cable	L1, L2, L3	AWG16 (1.25 mm <sup>2</sup> )	-	-		
	Servo Motor Main Circuit Cable*	U, V, W					
	Control Power Supply Cable	L1C, L2C					
	External Regenerative Resistor Cable	B1/⊕, B2					
	Ground cable	⊕	AWG14 (2.0 mm <sup>2</sup> ) min.	M4	1.2 to 1.4		
5R5A	Main Circuit Power Supply Cable	L1, L2, L3	AWG16 (1.25 mm <sup>2</sup> )	-	-		
	Servo Motor Main Circuit Cable*	U, V, W					
	Control Power Supply Cable	L1C, L2C					
	External Regenerative Resistor Cable	B1/⊕, B2					
	Ground cable	⊕	AWG14 (2.0 mm <sup>2</sup> ) min.	M4	1.2 to 1.4		
7R6A	Main Circuit Power Supply Cable	L1, L2, L3	AWG16 (1.25 mm <sup>2</sup> )	-	-		
	Servo Motor Main Circuit Cable*	U, V, W					
	Control Power Supply Cable	L1C, L2C					
	External Regenerative Resistor Cable	B1/⊕, B2					
	Ground cable	⊕	AWG14 (2.0 mm <sup>2</sup> ) min.	M4	1.2 to 1.4		
120A	Main Circuit Power Supply Cable	L1, L2, L3	AWG14 (2.0 mm <sup>2</sup> )	-	-		
	Servo Motor Main Circuit Cable*	U, V, W					
	Control Power Supply Cable	L1C, L2C	AWG16 (1.25 mm <sup>2</sup> )	M4	1.2 to 1.4		
	External Regenerative Resistor Cable	B1/⊕, B2					
	Ground cable	⊕				AWG14 (2.0 mm <sup>2</sup> ) min.	
180A	Main Circuit Power Supply Cable	L1, L2, L3	AWG14 (2.0 mm <sup>2</sup> )			M4	1.2 to 1.4
	Servo Motor Main Circuit Cable*	U, V, W	AWG10 (5.5 mm <sup>2</sup> )				
	Control Power Supply Cable	L1C, L2C	AWG16 (1.25 mm <sup>2</sup> )				
	External Regenerative Resistor Cable	B1/⊕, B2					
	Ground cable	⊕		AWG14 (2.0 mm <sup>2</sup> ) min.			
200A	Main Circuit Power Supply Cable	L1, L2, L3	AWG12 (3.5 mm <sup>2</sup> )	M4	1.2 to 1.4		
	Servo Motor Main Circuit Cable*	U, V, W	AWG10 (5.5 mm <sup>2</sup> )				
	Control Power Supply Cable	L1C, L2C	AWG16 (1.25 mm <sup>2</sup> )				
	External Regenerative Resistor Cable	B1/⊕, B2					
	Ground cable	⊕				AWG14 (2.0 mm <sup>2</sup> ) min.	

Continued on next page.

**SERVOPACK Cables/Peripherals**

## SERVOPACK Peripheral Devices

Continued from previous page.

SERVOPACK Model: SGD7S-	Terminals		Wire Size	Screw Size	Tightening Torque [N·m]
330A	Main Circuit Power Supply Cable	L1, L2, L3	AWG8 (8.0 mm <sup>2</sup> )	M4	1.2 to 1.4
	Servo Motor Main Circuit Cable*	U, V, W			
	Control Power Supply Cable	L1C, L2C	AWG16 (1.25 mm <sup>2</sup> )		
	External Regenerative Resistor Cable	B1/⊕, B2	AWG14 (2.0 mm <sup>2</sup> )		
	Ground cable	⊕	AWG14 (2.0 mm <sup>2</sup> ) min.		
470A	Main Circuit Power Supply Cable	L1, L2, L3	AWG8 (8.0 mm <sup>2</sup> )	M5	2.2 to 2.4
	Servo Motor Main Circuit Cable*	U, V, W	AWG6 (14 mm <sup>2</sup> )		
	Control Power Supply Cable	L1C, L2C	AWG16 (1.25 mm <sup>2</sup> )		
	External Regenerative Resistor Cable	B1/⊕, B2	AWG14 (2.0 mm <sup>2</sup> )		
	Ground cable	⊕	AWG14 (2.0 mm <sup>2</sup> ) min.		
550A	Main Circuit Power Supply Cable	L1, L2, L3	AWG8 (8.0 mm <sup>2</sup> )	M5	2.2 to 2.4
	Servo Motor Main Circuit Cable*	U, V, W	AWG4 (22 mm <sup>2</sup> )		
	Control Power Supply Cable	L1C, L2C	AWG16 (1.25 mm <sup>2</sup> )		
	External Regenerative Resistor Cable	B1/⊕, B2	AWG10 (5.5 mm <sup>2</sup> )		
	Ground cable	⊕	AWG14 (2.0 mm <sup>2</sup> ) min.		
590A	Main Circuit Power Supply Cable	L1, L2, L3	AWG4 (22 mm <sup>2</sup> )	M6	2.7 to 3.0
	Servo Motor Main Circuit Cable*	U, V, W			
	Control Power Supply Cable	L1C, L2C	AWG16 (1.25 mm <sup>2</sup> )		
	External Regenerative Resistor Cable	B1/⊕, B2	AWG10 (5.5 mm <sup>2</sup> )		
	Ground cable	⊕	AWG14 (2.0 mm <sup>2</sup> ) min.		
780A	Main Circuit Power Supply Cable	L1, L2, L3	AWG3 (30 mm <sup>2</sup> )	M6	2.7 to 3.0
	Servo Motor Main Circuit Cable*	U, V, W			
	Control Power Supply Cable	L1C, L2C	AWG16 (1.25 mm <sup>2</sup> )		
	External Regenerative Resistor Cable	B1/⊕, B2	AWG8 (8.0 mm <sup>2</sup> )		
	Ground cable	⊕	AWG14 (2.0 mm <sup>2</sup> ) min.		

\* If you do not use the recommended Servo Motor Main Circuit Cable, use this table to select wires.



Single-phase, 200-VAC Wires for  $\Sigma$ -7S SERVOPACKs

SERVOPACK Model: SGD7S-	Terminals		Wire Size	Screw Size	Tightening Torque [N·m]
R70A	Main Circuit Power Supply Cable	L1, L2	AWG16 (1.25 mm <sup>2</sup> )	-	-
	Servo Motor Main Circuit Cable*	U, V, W			
	Control Power Supply Cable	L1C, L2C			
	External Regenerative Resistor Cable	B1/⊕, B2			
	Ground cable	⊕	AWG14 (2.0 mm <sup>2</sup> ) min.	M4	1.2 to 1.4
R90A	Main Circuit Power Supply Cable	L1, L2	AWG16 (1.25 mm <sup>2</sup> )	-	-
	Servo Motor Main Circuit Cable*	U, V, W			
	Control Power Supply Cable	L1C, L2C			
	External Regenerative Resistor Cable	B1/⊕, B2			
	Ground cable	⊕	AWG14 (2.0 mm <sup>2</sup> ) min.	M4	1.2 to 1.4
1R6A	Main Circuit Power Supply Cable	L1, L2, L3	AWG16 (1.25 mm <sup>2</sup> )	-	-
	Servo Motor Main Circuit Cable*	U, V, W			
	Control Power Supply Cable	L1C, L2C			
	External Regenerative Resistor Cable	B1/⊕, B2			
	Ground cable	⊕	AWG14 (2.0 mm <sup>2</sup> ) min.	M4	1.2 to 1.4
2R8A	Main Circuit Power Supply Cable	L1, L2, L3	AWG16 (1.25 mm <sup>2</sup> )	-	-
	Servo Motor Main Circuit Cable*	U, V, W			
	Control Power Supply Cable	L1C, L2C			
	External Regenerative Resistor Cable	B1/⊕, B2			
	Ground cable	⊕	AWG14 (2.0 mm <sup>2</sup> ) min.	M4	1.2 to 1.4
5R5A	Main Circuit Power Supply Cable	L1, L2, L3	AWG14 (2.0 mm <sup>2</sup> )	-	-
	Servo Motor Main Circuit Cable*	U, V, W	AWG16 (1.25 mm <sup>2</sup> )		
	Control Power Supply Cable	L1C, L2C			
	External Regenerative Resistor Cable	B1/⊕, B2			
	Ground cable	⊕	AWG14 (2.0 mm <sup>2</sup> ) min.	M4	1.2 to 1.4

\* If you do not use the recommended Servo Motor Main Circuit Cable, use this table to select wires.

DC Power Supply Wires for  $\Sigma$ -7S SERVOPACKs

SERVOPACK Model: SGD7S-	Terminal Symbols*1		Wire Size	Screw Size	Tightening Torque [N·m]
R70A	Servo Motor Main Circuit Cables	U, V, W <sup>2</sup>	AWG16 (1.25 mm <sup>2</sup> )	–	–
	Control Power Supply Cables	L1C, L2C	AWG16 (1.25 mm <sup>2</sup> )	–	–
	Main Circuit Power Supply Cables	B1/⊕, ⊖2	AWG16 (1.25 mm <sup>2</sup> )	–	–
	Ground Cable	⊕	AWG14 (2.0 mm <sup>2</sup> ) or larger	M4	1.2 to 1.4
R90A	Servo Motor Main Circuit Cables	U, V, W <sup>2</sup>	AWG16 (1.25 mm <sup>2</sup> )	–	–
	Control Power Supply Cables	L1C, L2C	AWG16 (1.25 mm <sup>2</sup> )	–	–
	Main Circuit Power Supply Cables	B1/⊕, ⊖2	AWG16 (1.25 mm <sup>2</sup> )	–	–
	Ground Cable	⊕	AWG14 (2.0 mm <sup>2</sup> ) or larger	M4	1.2 to 1.4
1R6A	Servo Motor Main Circuit Cables	U, V, W <sup>2</sup>	AWG16 (1.25 mm <sup>2</sup> )	–	–
	Control Power Supply Cables	L1C, L2C	AWG16 (1.25 mm <sup>2</sup> )	–	–
	Main Circuit Power Supply Cables	B1/⊕, ⊖2	AWG16 (1.25 mm <sup>2</sup> )	–	–
	Ground Cable	⊕	AWG14 (2.0 mm <sup>2</sup> ) or larger	M4	1.2 to 1.4
2R8A	Servo Motor Main Circuit Cables	U, V, W <sup>2</sup>	AWG16 (1.25 mm <sup>2</sup> )	–	–
	Control Power Supply Cables	L1C, L2C	AWG16 (1.25 mm <sup>2</sup> )	–	–
	Main Circuit Power Supply Cables	B1/⊕, ⊖2	AWG16 (1.25 mm <sup>2</sup> )	–	–
	Ground Cable	⊕	AWG14 (2.0 mm <sup>2</sup> ) or larger	M4	1.2 to 1.4
3R8A	Servo Motor Main Circuit Cables	U, V, W <sup>2</sup>	AWG16 (1.25 mm <sup>2</sup> )	–	–
	Control Power Supply Cables	L1C, L2C	AWG16 (1.25 mm <sup>2</sup> )	–	–
	Main Circuit Power Supply Cables	B1/⊕, ⊖2	AWG16 (1.25 mm <sup>2</sup> )	–	–
	Ground Cable	⊕	AWG14 (2.0 mm <sup>2</sup> ) or larger	M4	1.2 to 1.4
5R5A	Servo Motor Main Circuit Cables	U, V, W <sup>2</sup>	AWG16 (1.25 mm <sup>2</sup> )	–	–
	Control Power Supply Cables	L1C, L2C	AWG16 (1.25 mm <sup>2</sup> )	–	–
	Main Circuit Power Supply Cables	B1/⊕, ⊖2	AWG16 (1.25 mm <sup>2</sup> )	–	–
	Ground Cable	⊕	AWG14 (2.0 mm <sup>2</sup> ) or larger	M4	1.2 to 1.4
7R6A	Servo Motor Main Circuit Cables	U, V, W <sup>2</sup>	AWG16 (1.25 mm <sup>2</sup> )	–	–
	Control Power Supply Cables	L1C, L2C	AWG16 (1.25 mm <sup>2</sup> )	–	–
	Main Circuit Power Supply Cables	B1/⊕, ⊖2	AWG16 (1.25 mm <sup>2</sup> )	–	–
	Ground Cable	⊕	AWG14 (2.0 mm <sup>2</sup> ) or larger	M4	1.2 to 1.4

Continued on next page.

Continued from previous page.

SERVOPACK Model: SGD7S-	Terminal Symbols*1		Wire Size	Screw Size	Tightening Torque [N·m]
120A	Servo Motor Main Circuit Cables	U, V, W <sup>2</sup>	AWG14 (2.0 mm <sup>2</sup> )	–	–
	Control Power Supply Cables	L1C, L2C	AWG16 (1.25 mm <sup>2</sup> )	–	–
	Main Circuit Power Supply Cables	B1/⊕, ⊖2	AWG14 (2.0 mm <sup>2</sup> )	–	–
	Ground Cable	⊕	AWG14 (2.0 mm <sup>2</sup> ) or larger	M4	1.2 to 1.4
180A	Servo Motor Main Circuit Cables	U, V, W <sup>2</sup>	AWG10 (5.5 mm <sup>2</sup> )	M4	1.2 to 1.4
	Control Power Supply Cables	L1C, L2C	AWG16 (1.25 mm <sup>2</sup> )	M4	1.2 to 1.4
	Main Circuit Power Supply Cables	B1/⊕, ⊖2	AWG10 (5.5 mm <sup>2</sup> )	M4	1.2 to 1.4
	Ground Cable	⊕	AWG14 (2.0 mm <sup>2</sup> ) or larger	M4	1.2 to 1.4
200A	Servo Motor Main Circuit Cables	U, V, W <sup>2</sup>	AWG10 (5.5 mm <sup>2</sup> )	M4	1.2 to 1.4
	Control Power Supply Cables	L1C, L2C	AWG16 (1.25 mm <sup>2</sup> )	M4	1.2 to 1.4
	Main Circuit Power Supply Cables	B1/⊕, ⊖2	AWG10 (5.5 mm <sup>2</sup> )	M4	1.2 to 1.4
	Ground Cable	⊕	AWG14 (2.0 mm <sup>2</sup> ) or larger	M4	1.2 to 1.4
330A	Servo Motor Main Circuit Cables	U, V, W	AWG8 (8.0 mm <sup>2</sup> )	M4	1.2 to 1.4
	Control Power Supply Cables	L1C, L2C	AWG16 (1.25 mm <sup>2</sup> )	M4	1.2 to 1.4
	Main Circuit Power Supply Cables	B1/⊕, ⊖2	AWG8 (8.0 mm <sup>2</sup> )	M4	1.2 to 1.4
	Ground Cable	⊕	AWG14 (2.0 mm <sup>2</sup> ) or larger	M4	1.2 to 1.4
470A	Servo Motor Main Circuit Cables	U, V, W	AWG6 (14 mm <sup>2</sup> )	M5	2.2 to 2.4
	Control Power Supply Cables	L1C, L2C	AWG16 (1.25 mm <sup>2</sup> )	M5	2.2 to 2.4
	Main Circuit Power Supply Cables	B1/⊕, ⊖2	AWG8 (8.0 mm <sup>2</sup> )	M5	2.2 to 2.4
	Ground Cable	⊕	AWG14 (2.0 mm <sup>2</sup> ) or larger	M5	2.2 to 2.4
550A	Servo Motor Main Circuit Cables	U, V, W	AWG4 (22 mm <sup>2</sup> )	M5	2.2 to 2.4
	Control Power Supply Cables	L1C, L2C	AWG16 (1.25 mm <sup>2</sup> )	M5	2.2 to 2.4
	Main Circuit Power Supply Cables	B1/⊕, ⊖2	AWG6 (14 mm <sup>2</sup> )	M5	2.2 to 2.4
	Ground Cable	⊕	AWG14 (2.0 mm <sup>2</sup> ) or larger	M5	2.2 to 2.4
590A	Servo Motor Main Circuit Cables	U, V, W	AWG4 (22 mm <sup>2</sup> )	M6	2.7 to 3.0
	Control Power Supply Cables	L1C, L2C	AWG16 (1.25 mm <sup>2</sup> )	M6	2.7 to 3.0
	Main Circuit Power Supply Cables	B1/⊕, ⊖2	AWG3 (30 mm <sup>2</sup> )	M6	2.7 to 3.0
	Ground Cable	⊕	AWG14 (2.0 mm <sup>2</sup> ) or larger	M6	2.7 to 3.0

Continued on next page.

**SERVOPACK Cables/Peripherals**

## SERVOPACK Peripheral Devices

Continued from previous page.

SERVOPACK Model: SGD7S-	Terminal Symbols*1		Wire Size	Screw Size	Tightening Torque [N·m]
780A	Servo Motor Main Circuit Cables	U, V, W	AWG3 (30 mm <sup>2</sup> )	M6	2.7 to 3.0
	Control Power Supply Cables	L1C, L2C	AWG16 (1.25 mm <sup>2</sup> )	M6	2.7 to 3.0
	Main Circuit Power Supply Cables	B1/⊕, ⊖2	AWG3 (30 mm <sup>2</sup> )	M6	2.7 to 3.0
	Ground Cable	⊕	AWG14 (2.0 mm <sup>2</sup> ) or larger	M6	2.7 to 3.0

\*1. Do not wire the following terminals: L1, L2, L3, B2, B3, ⊖1, and ⊖ terminals.

\*2. If you do not use the recommended Servo Motor Main Circuit Cable, use this table to select wires.

Three-phase, 200-VAC Wires for  $\Sigma$ -7W SERVOPACKs

SERVOPACK Model: SGD7W-	Terminals		Wire Size	Screw Size	Tightening Torque [N·m]
1R6A	Main Circuit Power Supply Cable	L1, L2, L3	AWG16 (1.25 mm <sup>2</sup> )	-	-
	Servo Motor Main Circuit Cable*	UA, VA, WA, UB, VB, WB			
	Control Power Supply Cable	L1C, L2C			
	External Regenerative Resistor Cable	B1/⊕, B2			
	Ground cable	⊕	AWG14 (2.0 mm <sup>2</sup> ) min.	M4	1.2 to 1.4
2R8A	Main Circuit Power Supply Cable	L1, L2, L3	AWG14 (2.0 mm <sup>2</sup> )	-	-
	Servo Motor Main Circuit Cable*	UA, VA, WA, UB, VB, WB	AWG16 (1.25 mm <sup>2</sup> )		
	Control Power Supply Cable	L1C, L2C			
	External Regenerative Resistor Cable	B1/⊕, B2			
	Ground cable	⊕	AWG14 (2.0 mm <sup>2</sup> ) min.	M4	1.2 to 1.4
5R5A	Main Circuit Power Supply Cable	L1, L2, L3	AWG14 (2.0 mm <sup>2</sup> )	-	-
	Servo Motor Main Circuit Cable*	UA, VA, WA, UB, VB, WB	AWG16 (1.25 mm <sup>2</sup> )		
	Control Power Supply Cable	L1C, L2C	AWG14 (2.0 mm <sup>2</sup> )		
	External Regenerative Resistor Cable	B1/⊕, B2			
	Ground cable	⊕	AWG14 (2.0 mm <sup>2</sup> ) min.	M4	1.2 to 1.4
7R6A	Main Circuit Power Supply Cable	L1, L2, L3	AWG14 (2.0 mm <sup>2</sup> )	-	-
	Servo Motor Main Circuit Cable*	UA, VA, WA, UB, VB, WB	AWG16 (1.25 mm <sup>2</sup> )		
	Control Power Supply Cable	L1C, L2C	AWG14 (2.0 mm <sup>2</sup> )		
	External Regenerative Resistor Cable	B1/⊕, B2			
	Ground cable	⊕	AWG14 (2.0 mm <sup>2</sup> ) min.	M4	1.2 to 1.4

\* If you do not use the recommended Servo Motor Main Circuit Cable, use this table to select wires.

Single-phase, 200-VAC Wires for  $\Sigma$ -7W SERVOPACKs

SERVOPACK Model: SGD7W-	Terminals		Wire Size	Screw Size	Tightening Torque [N·m]
1R6A	Main Circuit Power Supply Cable	L1, L2, L3	AWG16 (1.25 mm <sup>2</sup> )	-	-
	Servo Motor Main Circuit Cable*	UA, VA, WA, UB, VB, WB			
	Control Power Supply Cable	L1C, L2C			
	External Regenerative Resistor Cable	B1/⊕, B2			
	Ground cable	⊕	AWG14 (2.0 mm <sup>2</sup> ) min.	M4	1.2 to 1.4
2R8A	Main Circuit Power Supply Cable	L1, L2, L3	AWG14 (2.0 mm <sup>2</sup> )	-	-
	Servo Motor Main Circuit Cable*	UA, VA, WA, UB, VB, WB	AWG16 (1.25 mm <sup>2</sup> )		
	Control Power Supply Cable	L1C, L2C			
	External Regenerative Resistor Cable	B1/⊕, B2			
	Ground cable	⊕	AWG14 (2.0 mm <sup>2</sup> ) min.	M4	1.2 to 1.4
5R5A	Main Circuit Power Supply Cable	L1, L2, L3	AWG14 (2.0 mm <sup>2</sup> )	-	-
	Servo Motor Main Circuit Cable*	UA, VA, WA, UB, VB, WB	AWG16 (1.25 mm <sup>2</sup> )		
	Control Power Supply Cable	L1C, L2C	AWG14 (2.0 mm <sup>2</sup> )		
	External Regenerative Resistor Cable	B1/⊕, B2			
	Ground cable	⊕	AWG14 (2.0 mm <sup>2</sup> ) min.	M4	1.2 to 1.4

\* If you do not use the recommended Servo Motor Main Circuit Cable, use this table to select wires.

DC Power Supply Wires for  $\Sigma$ -7W SERVOPACKs

SERVOPACK Model: SGD7W-	Terminal Symbols*1		Wire Size	Screw Size	Tightening Torque [N·m]
1R6A	Servo Motor Main Circuit Cables	UA, VA, WA, UB, VB, WB*2	AWG16 (1.25 mm <sup>2</sup> )	-	-
	Control Power Supply Cables	L1C, L2C	AWG16 (1.25 mm <sup>2</sup> )	-	-
	Main Circuit Power Supply Cables	B1/⊕, ⊖2	AWG16 (1.25 mm <sup>2</sup> )	-	-
	Ground Cable	⊕	AWG14 (2.0 mm <sup>2</sup> ) or larger	M4	1.2 to 1.4
2R8A	Servo Motor Main Circuit Cables	UA, VA, WA, UB, VB, WB*2	AWG16 (1.25 mm <sup>2</sup> )	-	-
	Control Power Supply Cables	L1C, L2C	AWG16 (1.25 mm <sup>2</sup> )	-	-
	Main Circuit Power Supply Cables	B1/⊕, ⊖2	AWG16 (1.25 mm <sup>2</sup> )	-	-
	Ground Cable	⊕	AWG14 (2.0 mm <sup>2</sup> ) or larger	M4	1.2 to 1.4

Continued on next page.

Continued from previous page.

SERVOPACK Model: SGD7W-	Terminal Symbols*1		Wire Size	Screw Size	Tightening Torque [N·m]
5R5A	Servo Motor Main Circuit Cables	UA, VA, WA, UB, VB, WB <sup>2</sup>	AWG16 (1.25 mm <sup>2</sup> )	–	–
	Control Power Supply Cables	L1C, L2C	AWG16 (1.25 mm <sup>2</sup> )	–	–
	Main Circuit Power Supply Cables	B1/⊕, ⊖2	AWG14 (2.0 mm <sup>2</sup> )	–	–
	Ground Cable	⊕	AWG14 (2.0 mm <sup>2</sup> ) or larger	M4	1.2 to 1.4
7R6A	Servo Motor Main Circuit Cables	UA, VA, WA, UB, VB, WB <sup>2</sup>	AWG16 (1.25 mm <sup>2</sup> )	–	–
	Control Power Supply Cables	L1C, L2C	AWG16 (1.25 mm <sup>2</sup> )	–	–
	Main Circuit Power Supply Cables	B1/⊕, ⊖2	AWG14 (2.0mm <sup>2</sup> )	–	–
	Ground Cable	⊕	AWG14 (2.0 mm <sup>2</sup> ) or larger	M4	1.2 to 1.4

\*1. Do not wire the following terminals: L1, L2, L3, B2, B3, ⊕1, and ⊖ terminals.

\*2. If you do not use the recommended Servo Motor Main Circuit Cable, use this table to select wires.

## Wire Types

The following table shows the wire sizes and allowable currents for three bundled leads.

HIV Specifications*		Allowable Current at Surrounding Air Temperatures [Arms]		
Nominal Cross-sectional Area [mm <sup>2</sup> ]	Configuration [Wires/mm <sup>2</sup> ]	30°C	40°C	50°C
0.9	7/0.4	15	13	11
1.25	7/0.45	16	14	12
2.0	7/0.6	23	20	17
3.5	7/0.8	32	28	24
5.5	7/1.0	42	37	31
8.0	7/1.2	52	46	39
14.0	7/1.6	75	67	56
22.0	7/2.0	98	87	73
38.0	7/2.6	138	122	103

\* This is reference data based on JIS C3317 600-V-grade heat-resistant polyvinyl chloride-insulated wires (HIV).



## Crimp Terminals and Insulating Sleeves

If you use crimp terminals for wiring, use insulating sleeves. Do not allow the crimp terminals to come close to adjacent terminals or the case.

To comply with UL standards, you must use UL-compliant closed-loop crimp terminals and insulating sleeves for the main circuit terminals. Use the tool recommended by the crimp terminal manufacturer to attach the crimp terminals.

The following tables give the recommended tightening torques, closed-loop crimp terminals, and insulating sleeves in sets. Use the set that is suitable for your model and wire size.

### Σ-7S SERVOPACKs for Use with Three-Phase, 200-VAC and DC Power Supply

SERVOPACK Model: SGD7S-	Main Circuit Terminals	Screw Size	Tightening Torque [N·m]	Crimp Terminal Horizontal Width	Recommended Wire Size	Crimp Terminal Model	Crimping Tool	Die	Insulating Sleeve Model
						(From J.S.T. Mfg. Co., Ltd.)			(Tokyo Dip Co., Ltd.)
R70A, R90A, 1R6A, 2R8A, 3R8A, 5R5A, 7R6A, or 120A	Connector	-							
		M4	1.2 to 1.4	10 mm max.	AWG14 (2.0 mm <sup>2</sup> )	R2-4	YHT-2210	-	-
180A or 200A	Terminal block	M4	1.2 to 1.4	7.7 mm max.	AWG10 (5.5 mm <sup>2</sup> )	5.5-S4	YHT-2210	-	TP-005
					AWG14 (2.0 mm <sup>2</sup> )	2-M4		-	TP-003
	AWG16 (1.25 mm <sup>2</sup> )	-							
330A	Terminal block	M4	1.2 to 1.4	9.9 mm max.	AWG8 (8.0 mm <sup>2</sup> )	8-4NS	YPT-60N	TD-121 TD-111	TP-008
					AWG14 (2.0 mm <sup>2</sup> )	R2-4	YHT-2210	-	TP-003
	AWG16 (1.25 mm <sup>2</sup> )	-							
470A or 550A	Terminal block	M5	2.2 to 2.4	13 mm max.	AWG4 (22 mm <sup>2</sup> )	22-S5	YPT-60N	TD-123 TD-112	TP-022
					AWG6 (14 mm <sup>2</sup> )	R14-5		TD-122 TD-111	TP-014
					AWG8 (8.0 mm <sup>2</sup> )	R8-5		TD-121 TD-111	TP-008
					AWG10 (5.5 mm <sup>2</sup> )	R5.5-5	-	TP-005	
					AWG14 (2.0 mm <sup>2</sup> )	R2-5	YHT-2210	-	TP-003
	AWG16 (1.25 mm <sup>2</sup> )	-							
470A or 550A		M5	2.2 to 2.4	12 mm max.	AWG14 (2.0 mm <sup>2</sup> )	R2-5	YHT-2210	-	-

Continued on next page.



Continued from previous page.

SERVOPACK Model: SGD7S-	Main Circuit Ter- minals	Screw Size	Tightening Torque [N·m]	Crimp Terminal Horizontal Width	Recom- mended Wire Size	Crimp Terminal Model	Crimping Tool	Die	Insulating Sleeve Model
						(From J.S.T. Mfg. Co., Ltd.)			(Tokyo Dip Co., Ltd.)
590A or 780A	Terminal block	M6	2.7 to 3.0	18 mm max.	AWG3 (30 mm <sup>2</sup> )	38-S6	YPT-60N	TD-124 TD-112	TP-038
					AWG4 (22 mm <sup>2</sup> )	R22-6		TD-123 TD-112	TP-022
					AWG8 (8.0 mm <sup>2</sup> )	R8-6		TD-121 TD-111	TP-008
					AWG10 (5.5 mm <sup>2</sup> )	R5.5-6	YHT- 2210	–	TP-005
					AWG14 (2.0 mm <sup>2</sup> )	R2-6		–	TP-003
					AWG16 (1.25 mm <sup>2</sup> )			–	
		M6	2.7 to 3.0	12 mm max.	AWG14 (2.0 mm <sup>2</sup> )	R2-6	YHT- 2210	–	–

### Σ-7S SERVOPACKs for Use with Single-Phase, 200-VAC Power Supply

SERVOPACK Model: SGD7S-	Main Circuit Terminals	Screw Size	Tightening Torque [N·m]	Crimp Terminal Horizontal Width	Recommended Wire Size	Crimp Terminal Model	Crimping Tool	Die	Insulating Sleeve Model
						(From J.S.T. Mfg. Co., Ltd.)			
R70A, R90A, 1R6A, 2R8A, or 5R5A	Connector	-							
		M4	1.2 to 1.4	10 mm max.	AWG14 (2.0 mm <sup>2</sup> )	R2-4	YHT-2210	-	-

### Σ-7W SERVOPACKs for Use with Three-Phase, 200-VAC and DC Power Supply

SERVOPACK Model: SGD7W-	Main Circuit Terminals	Screw Size	Tightening Torque [N·m]	Crimp Terminal Horizontal Width	Recommended Wire Size	Crimp Terminal Model	Crimping Tool	Die	Insulating Sleeve Model
						(From J.S.T. Mfg. Co., Ltd.)			
1R6A, 2R8A, 5R5A, or 7R6A	Connector	-							
		M4	1.2 to 1.4	10 mm max.	AWG14 (2.0 mm <sup>2</sup> )	R2-4	YHT-2210	-	-

### Σ-7W SERVOPACKs for Use with Single-Phase, 200-VAC Power Supply

SERVOPACK Model: SGD7W-	Main Circuit Terminals	Screw Size	Tightening Torque [N·m]	Crimp Terminal Horizontal Width	Recommended Wire Size	Crimp Terminal Model	Crimping Tool	Die	Insulating Sleeve Model
						(From J.S.T. Mfg. Co., Ltd.)			
1R6A, 2R8A, or 5R5A	Connector	-							
		M4	1.2 to 1.4	10 mm max.	AWG14 (2.0 mm <sup>2</sup> )	R2-4	YHT-2210	-	-

## Surge Absorbers (Varistors) and Diodes for Holding Brake Power Supplies

Surge Absorbers (varistors) and Diodes for holding brake power supplies help prevent damage to brake coils caused by voltage surges.

If you use a Servo Motor with a Holding Brake and switch the brake power supply circuit on the DC side, connect a Surge Absorber (varistor) or Diode that is suitable for the brake power supply voltage and current.



Note

- When you select a Surge Absorber, varistor, or Diode for your application, consider the service life and test all operations, including the brake timing, before you use the Servo Motor.
- If you connect an SSR (i.e., a semiconductor relay) to switch the brake circuit, use a Diode.
- If you connect a Diode, more time is required to brake than with a Surge Absorber. (Refer to the following figure.) If you use a diode, consider this in the application.

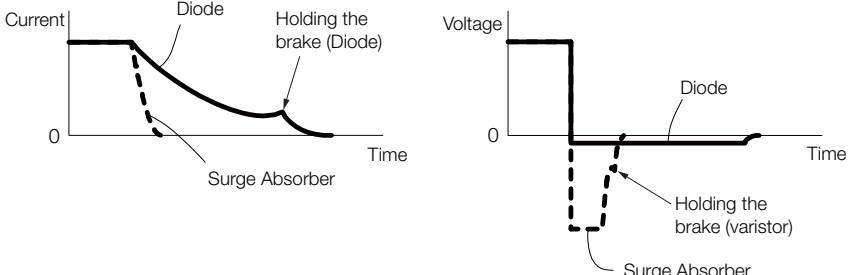

### ◆ Surge Absorbers (Varistors) for Holding Brake Power Supplies

Use the following table as reference in selecting a Surge Absorber. Elements were selected for a Surge Absorber surrounding air temperature range of -20°C to 60°C and an ON/OFF switching frequency of 10 times or less per minute. The information in this table is for reference only, and does not ensure operation in combination with the holding brake.

Holding Brake Power Supply Voltage		24 VDC	
Manufacturer		Nippon Chemi-Con Corporation	Semitec Corporation
		Order Number	
Brake Rated Current	1 A max.	TNR5V121K	Z5D121
	2 A max.	TNR7V121K	Z7D121
	4 A max.	TNR10V121K	Z10D121
	8 A max.	TNR14V121K	Z15D121

### ◆ Diodes for Holding Brake Power Supplies

Select a Diode for the holding brake power supply with a rated current that is greater than that of the holding brake and with the recommended withstand voltage given in the following table.

Diodes are not provided by Yaskawa.

Holding Brake Power Supply Unit Specifications		Withstand Voltage
Rated Output Voltage	Input Voltage	
24 VDC	200 V	100 V to 200 V

## Regenerative Resistors

### Types of Regenerative Resistors

The following regenerative resistors can be used.

- Built-in regenerative resistors: Some models of SERVOPACKs have regenerative resistors built into them.
- External regenerative resistors: These resistors are used when the smoothing capacitor and built-in regenerative resistor in the SERVOPACK cannot consume all of the regenerative power. Use Yaskawa's SigmaJunmaSize+, an AC Servo drive capacity selection program, to determine if a regenerative resistor is required.

Note: If you use an External Regenerative Resistor, you must change the setting of the Pn600 (Regenerative Resistor Capacity) or Pn603 (Regenerative Resistance) parameters.

### Selection Table

SERVOPACK Model		Built-In Regenerative Resistor	External Regenerative Resistor	Contents
SGD7S-	SGD7W-			
R70A, R90A, 1R6A, 2R8A	–	None	Basically not required	There is no built-in regenerative resistor, but normally an external regenerative resistor is not required. Install an external regenerative resistor when the smoothing capacitor in the SERVOPACK cannot process all the regenerative power.*1
3R8A, 5R5A, 7R6A, 120A, 180A, 200A, 330A	1R6A, 2R8A, 5R5A, 7R6A	Standard feature*2	Basically not required	A built-in regenerative resistor is provided as a standard feature. Install an external regenerative resistor when the built-in regenerative resistor cannot process all the regenerative power.*1
470A, 550A, 590A, 780A	–	None	Required.*3	A built-in regenerative resistor is not provided. An External Regenerative Resistor is required. If the External Regenerative Resistor is not connected to the SERVOPACK, a Regeneration Alarm (A.300) will occur.

\*1. Use Yaskawa's SigmaJunmaSize+, an AC Servo drive capacity selection program, to select an external regenerative resistor.

\*2. Refer to the following section for the specifications of built-in regenerative resistors.

 *Built-In Regenerative Resistor* (page 385)

\*3. Regenerative Resistor Units are available. Refer to the following sections for details.

 *Regenerative Resistor Units* (page 386)

## Built-In Regenerative Resistor

The following table gives the specifications of the built-in regenerative resistors in the SERVOPACKs and the amount of regenerative power (average values) that they can process.

SERVOPACK Model		Built-In Regenerative Resistor		Regenerative Power Processing Capacity of Built-In Regenerative Resistor [W]	Minimum Allowable Resistance [ $\Omega$ ]
SGD7S-	SGD7W-	Resistance [ $\Omega$ ]	Capacity [W]		
R70A, R90A, 1R6A, 2R8A	–	–	–	–	40
3R8A, 5R5A, 7R6A	1R6A, 2R8A	40	40	8	40
120A	–	20	60	10	20
180A, 200A	5R5A, 7R6A	12	60	16	12
330A	–	8	180	36	8
470A	–	(6.25) <sup>*1</sup>	(880) <sup>*1</sup>	(180) <sup>*1</sup>	5.8
550A, 590A, 780A	–	(3.13) <sup>*2</sup>	(1760) <sup>*2</sup>	(350) <sup>*2</sup>	2.9

\*1. Values in parentheses are for the optional JUSP-RA04-E Regenerative Resistor Unit.

\*2. Values in parentheses are for the optional JUSP-RA05-E Regenerative Resistor Unit.

## External Regenerative Resistors

Model	Specification	Inquiries	Manufacturer
RH120	70 W, 1 $\Omega$ to 100 $\Omega$	Yaskawa Controls Co., Ltd.	Iwaki Musen Kenkyusho Co., Ltd.
RH150	90 W, 1 $\Omega$ to 100 $\Omega$		
RH220 or RH220B	120 W, 1 $\Omega$ to 100 $\Omega$		
RH300C	200 W, 1 k $\Omega$ to 10 k $\Omega$		
RH500	300 W, 2 $\Omega$ to 50 $\Omega$		

Note: 1. Consult Yaskawa Controls Co., Ltd. if you require a RoHS-compliant resistor.

2. Consult Yaskawa Controls Co., Ltd. for the model numbers and specifications of resistors with thermostats.

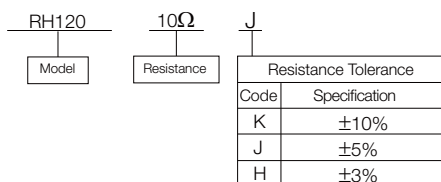

## Regenerative Resistor Units

SERVOPACK Model: SGD7S-	Regenerative Resistor Unit Model	Specifications	Allowable Power Loss
470A	JUSP-RA04-E	6.25 Ω, 880 W	180 W
550A, 590A, or 780A	JUSP-RA05-E	3.13 Ω, 1,760 W	350 W

Note: If you use only the above Regenerative Resistor Units, you do not need to change the setting of the Pn600 (Regenerative Resistor Capacity) or Pn603 (Regenerative Resistance) parameters.

### ◆ External Dimensions

#### ■ JUSP-RA04-E

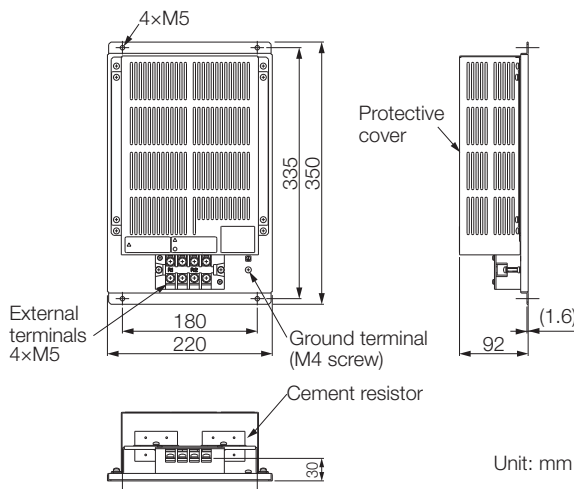

#### ■ JUSP-RA05-E

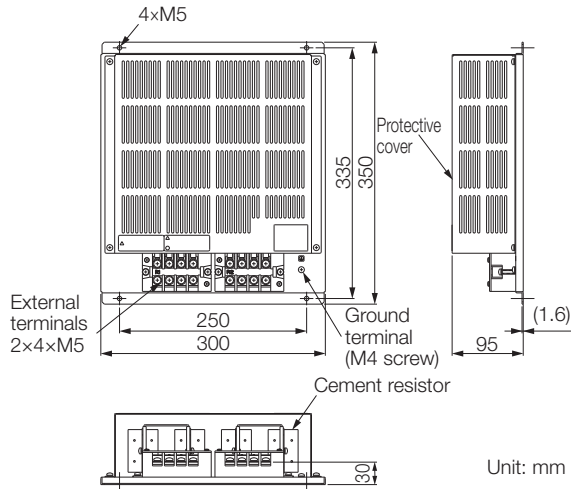

## Batteries for Servo Motor with Absolute Encoders

If you use an absolute encoder, you can use an Encoder Cable with a Battery Case connected to it to supply power and retain the absolute position data.

You can also retain the absolute position data by supplying power from a battery on the host controller.

The Battery Case is sold as a replacement part for the Battery Case that is included with an Absolute Encoder Cable.

Name	Order Number	Remarks
Battery Case (case only)	JUSP-BA01-E	The Encoder Cable and Battery are not included. (This is a replacement part for a damaged Battery Case.)
Lithium Battery	JZSP-BA01	This is a special battery that mounts into the Battery Case.



**Important**

1. You cannot attach the Battery Case to an Incremental Encoder Cable.
2. Install the Battery Case where the surrounding air temperature is between -5°C and 60°C.

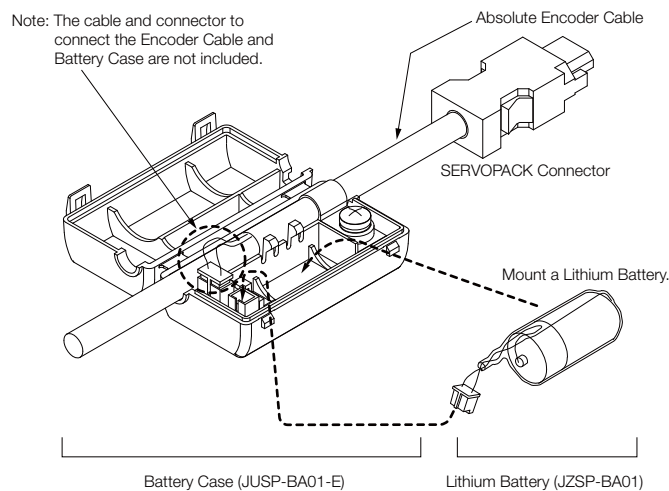

### ◆ Mounting a Battery in the Battery Case

Obtain a Lithium Battery (JZSP-BA01) and mount it in the Battery Case.

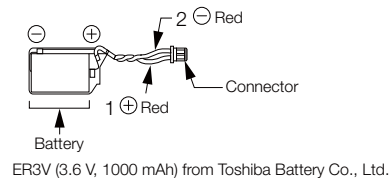

### ◆ Connecting a Battery to the Host Controller

Use a battery that meets the specifications of the host controller. Use an ER6VC3N Battery (3.6 V, 2,000 mAh) from Toshiba Battery Co., Ltd. or an equivalent battery.

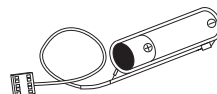

## Current Suppression Devices

Inrush current suppression devices prevent equipment from being damaged by inrush current.

They are used only when using a SERVOPACK of 5 kW or higher (SGD7S-330A, -470A, -550A, -590A, or -780A) with a DC power supply input.

### Selection Table

#### ◆ External Inrush Current Suppression Resistors

Main Circuit Power Supply	SERVO-PACK Model: SGD7S-	External Inrush Current Suppression Resistor			Manufacturer	Inquiries
		Order Number	Resistance [ $\Omega$ ]	Rated Power [W]		
270 VDC	330A	RH120-5 $\Omega$ J	5	70	Iwaki Musen Kenkyusho Co., Ltd.	Yaskawa Controls Co.,Ltd.
	470A					
	550A					
	590A	RH120-3 $\Omega$ J	3			
	780A					

#### ◆ Inrush Current Suppression Resistor Short Relays

Main Circuit Power Supply	SERVO-PACK Model: SGD7S-	Main Circuit DC Current [Arms]	Contact Specification	Recommended Inrush Current Suppression Resistor Short Relay			Manufacturer	
				Model	Voltage Rating [Vdc]	Current Rating [A]		
270 VDC	330A	34	NO	G9EA-1-B	400	60	OMRON Corporation	
	470A	36				G9EA-1-B-CA		100
	550A	48						G9EA-1-B-CA <sup>*1</sup>
	590A	68		G9EC-1-B <sup>*2</sup>				
	780A	92						

\*1. Connect two Relays in parallel. Also, maintain the same resistance between the DC power supply and SERVOPACK for the wiring for each Relay.

\*2. This Relay is applicable only when the temperature of the Relay installation environment is 50°C or less.



## Software

### SigmaWin+: AC Servo Drive Engineering Tool

The SigmaWin+ Engineering Tool is used to set up and optimally tune Yaskawa  $\Sigma$ -series Servo Drives.

#### ◆ Features

- Set parameters with a wizard.
- Display SERVOPACK data on a computer just like you would on an oscilloscope.
- Estimate moments of inertia and measure vibration frequencies.
- Display alarms and alarm diagnostics.

Setting Parameters with a Wizard

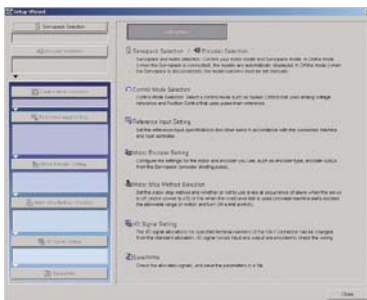

Displaying SERVOPACK Data on a Computer Just Like You Would on an Oscilloscope

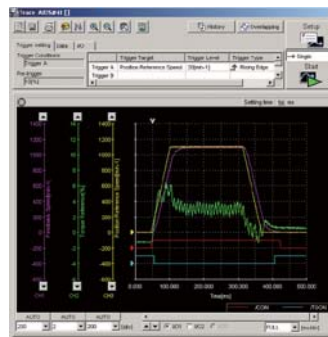

Estimating Moments of Inertia and Measuring Vibration Frequencies

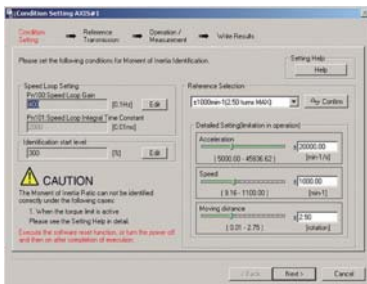

Displaying Alarms and Alarm Diagnostics



#### ◆ System Requirements

Item	System Requirement
Supported Languages	English and Japanese
OS	Windows XP, Windows Vista, or Windows 7 (32-bit or 64-bit edition)
CPU	Pentium 200 MHz min.
Memory	64 MB min. (96 MB or greater recommended)
Available Hard Disk Space	For Standard Setup: 350 MB min. (400 MB or greater recommended for installation)



# Appendices

---

Capacity Selection for Servo Motors .....	392
Capacity Selection for Regenerative Resistors .....	402
International Standards .....	418
Warranty .....	420

# Capacity Selection for Servo Motors

## Selecting the Servo Motor Capacity

Use Yaskawa's SigmaJunmaSize+, an AC servo drive capacity selection program, to select the Servo Motor capacity. With the SigmaJunmaSize+, you can find the optimum Servo Motor capacity by simply selecting and entering information according to instructions from a wizard.

Refer to the following selection examples to select Servo Motor capacities with manual calculations rather than with the above software.

### Capacity Selection Example for a Rotary Servo Motor: For Speed Control

#### 1. Mechanical Specifications

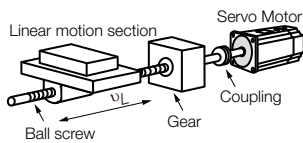

Item	Code	Value
Load Speed	$v_L$	15 m/min
Linear Motion Section Mass	$m$	250 kg
Ball Screw Length	$l_B$	1.0 m
Ball Screw Diameter	$d_B$	0.02 m
Ball Screw Lead	$P_B$	0.01 m
Ball Screw Material Density	$\rho$	$7.87 \times 10^3 \text{ kg/m}^3$
Gear Ratio	$R$	2 (gear ratio: 1/2)
External Force on Linear Motion Section	$F$	0 N

Item	Code	Value
Gear and Coupling Moment of Inertia	$J_G$	$0.40 \times 10^{-4} \text{ kg} \cdot \text{m}^2$
Number of Feeding Operations	$n$	40 operations/min
Feeding Distance	$l$	0.275 m
Feeding Time	$tm$	1.2 s max.
Friction Coefficient	$\mu$	0.2
Mechanical Efficiency	$\eta$	0.9 (90%)

#### 2. Operation Pattern

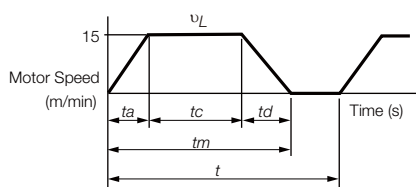

$$t = \frac{60}{n} = \frac{60}{40} = 1.5 \text{ (s)}$$

If  $t_a = t_d$ ,

$$t_a = t_m - \frac{60 \cdot l}{v_L} = 1.2 - \frac{60 \times 0.275}{15} = 1.2 - 1.1 = 0.1 \text{ (s)}$$

$$t_c = 1.2 - 0.1 \times 2 = 1.0 \text{ (s)}$$

#### 3. Motor Speed

- Load shaft speed  $n_L = \frac{v_L}{P_B} = \frac{15}{0.01} = 1,500 \text{ (min}^{-1}\text{)}$
- Motor shaft speed  $n_M = n_L \cdot R = 1,500 \times 2 = 3,000 \text{ (min}^{-1}\text{)}$

#### 4. Load Torque

$$T_L = \frac{(9.8 \cdot \mu \cdot m + F) \cdot P_B}{2\pi R \cdot \eta} = \frac{(9.8 \times 0.2 \times 250 + 0) \times 0.01}{2\pi \times 2 \times 0.9} = 0.43 \text{ (N}\cdot\text{m)}$$

**5. Load Moment of Inertia**

- Linear motion section

$$J_{L1} = m \left( \frac{P_B}{2\pi R} \right)^2 = 250 \times \left( \frac{0.01}{2\pi \times 2} \right)^2 = 1.58 \times 10^{-4} \text{ (kg}\cdot\text{m}^2\text{)}$$

- Ball screw

$$J_B = \frac{\pi}{32} \rho \cdot l_B \cdot d_B^4 \cdot \frac{1}{R^2} = \frac{\pi}{32} \times 7.87 \times 10^3 \times 1.0 \times (0.02)^4 \cdot \frac{1}{2^2} = 0.31 \times 10^{-4} \text{ (kg}\cdot\text{m}^2\text{)}$$

- Coupling  $J_G = 0.40 \times 10^{-4} \text{ (kg}\cdot\text{m}^2\text{)}$
- Load moment of inertia at motor shaft

$$J_L = J_{L1} + J_B + J_G = (1.58 + 0.31 + 0.40) \times 10^{-4} = 2.29 \times 10^{-4} \text{ (kg}\cdot\text{m}^2\text{)}$$

**6. Load Moving Power**

$$P_O = \frac{2\pi n_M \cdot T_L}{60} = \frac{2\pi \times 3,000 \times 0.43}{60} = 135 \text{ (W)}$$

**7. Load Acceleration Power**

$$P_a = \left( \frac{2\pi}{60} n_M \right)^2 \frac{J_L}{t_a} = \left( \frac{2\pi}{60} \times 3,000 \right)^2 \times \frac{2.29 \times 10^{-4}}{0.1} = 226 \text{ (W)}$$

**8. Servo Motor Provisional Selection**

① Selection Conditions

- $T_L \leq$  Motor rated torque
- $\frac{(P_O + P_a)}{2} <$  Provisionally selected Servo Motor rated output  $< (P_O + P_a)$
- $n_M \leq$  Rated motor speed
- $J_L \leq$  Allowable load moment of inertia

The following Servo Motor meets the selection conditions.

- SGM7J-02A Servo Motor

② Specifications of the Provisionally Selected Servo Motor

Item	Value
Rated Output	200 (W)
Rated Motor Speed	3,000 (min <sup>-1</sup> )
Rated Torque	0.637 (N·m)
Instantaneous Maximum Torque	2.23 (N·m)
Motor Moment of Inertia	$0.263 \times 10^{-4} \text{ (kg}\cdot\text{m}^2\text{)}$
Allowable Load Moment of Inertia	$0.263 \times 10^{-4} \times 15 = 3.94 \times 10^{-4} \text{ (kg}\cdot\text{m}^2\text{)}$

**9. Verification of the Provisionally Selected Servo Motor**

- Verification of required acceleration torque:

$$T_P = \frac{2\pi n_M (J_M + J_L)}{60 t_a} + T_L = \frac{2\pi \times 3,000 \times (0.263 + 2.29) \times 10^{-4}}{60 \times 0.1} + 0.43$$

$$\approx 1.23 \text{ (N}\cdot\text{m)} < \text{Maximum instantaneous torque...Satisfactory}$$

- Verification of required deceleration torque:

$$T_S = \frac{2\pi n_M (J_M + J_L)}{60 t_d} - T_L = \frac{2\pi \times 3,000 \times (0.263 + 2.29) \times 10^{-4}}{60 \times 0.1} - 0.43$$

$$\approx 0.37 \text{ (N}\cdot\text{m)} < \text{Maximum instantaneous torque...Satisfactory}$$

## Appendices

### Capacity Selection for Servo Motors

- Verification of effective torque value:

$$T_{rms} = \sqrt{\frac{T_P^2 \cdot t_a + T_L^2 \cdot t_c + T_S^2 \cdot t_d}{t}} = \sqrt{\frac{(1.23)^2 \times 0.1 + (0.43)^2 \times 1.0 + (0.37)^2 \times 0.1}{1.5}}$$

$$\approx 0.483 \text{ (N}\cdot\text{m)} < \text{Rated torque...Satisfactory}$$

## 10. Result

It has been verified that the provisionally selected Servo Motor is applicable.  
The torque diagram is shown below.

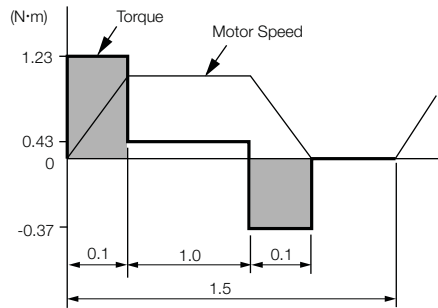

## Capacity Selection Example for a Rotary Servo Motor: For Position Control

### 1. Mechanical Specifications

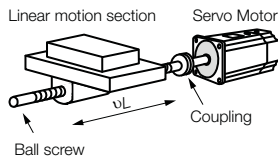

Item	Code	Value
Load Speed	$v_L$	15 m/min
Linear Motion Section Mass	$m$	80 kg
Ball Screw Length	$\ell_B$	0.8 m
Ball Screw Diameter	$d_B$	0.016 m
Ball Screw Lead	$P_B$	0.005 m
Ball Screw Material Density	$\rho$	$7.87 \times 10^3 \text{ kg/m}^3$
External Force on Linear Motion Section	$F$	0 N
Coupling Mass	$m_C$	0.3 kg

Item	Code	Value
Coupling Outer Diameter	$d_C$	0.03 m
Number of Feeding Operations	$n$	40 rotation/min
Feeding Distance	$\ell$	0.25 m
Feeding Time	$tm$	1.2 s max.
Electrical Stopping Precision	$\delta$	$\pm 0.01 \text{ mm}$
Friction Coefficient	$\mu$	0.2
Mechanical Efficiency	$\eta$	0.9 (90%)

### 2. Speed Diagram

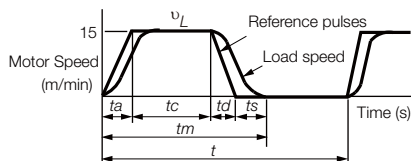

$$t = \frac{60}{n} = \frac{60}{40} = 1.5 \text{ (s)}$$

$$\text{If } t_a = t_d \text{ and } t_s = 0.1 \text{ (s),}$$

$$t_a = tm - t_s - \frac{60 \ell}{v_L} = 1.2 - 0.1 - \frac{60 \times 0.25}{15} = 0.1 \text{ (s)}$$

$$t_c = 1.2 - 0.1 - 0.1 \times 2 = 0.9 \text{ (s)}$$

### 3. Motor Speed

- Load shaft speed  $n_L = \frac{v_L}{P_B} = \frac{15}{0.005} = 3,000 \text{ (min}^{-1}\text{)}$
- Motor shaft speed Direct coupling gear ratio  $1/R = 1/1$   
Therefore,  $n_M = n_L \cdot R = 3,000 \times 1 = 3,000 \text{ (min}^{-1}\text{)}$

### 4. Load Torque

$$T_L = \frac{(9.8 \mu \cdot m + F) \cdot P_B}{2\pi R \cdot \eta} = \frac{(9.8 \times 0.2 \times 80 + 0) \times 0.005}{2\pi \times 1 \times 0.9} = 0.139 \text{ (N}\cdot\text{m)}$$

### 5. Load Moment of Inertia

- Linear motion section

$$J_{L1} = m \left( \frac{P_B}{2\pi R} \right)^2 = 80 \times \left( \frac{0.005}{2\pi \times 1} \right)^2 = 0.507 \times 10^{-4} \text{ (kg}\cdot\text{m}^2\text{)}$$

- Ball screw  $J_B = \frac{\pi}{32} \rho \cdot \ell_B \cdot d_B^4 = \frac{\pi}{32} \times 7.87 \times 10^3 \times 0.8 \times (0.016)^4 = 0.405 \times 10^{-4} \text{ (kg}\cdot\text{m}^2\text{)}$
- Coupling  $J_c = \frac{1}{8} m_C \cdot d_C^2 = \frac{1}{8} \times 0.3 \times (0.03)^2 = 0.338 \times 10^{-4} \text{ (kg}\cdot\text{m}^2\text{)}$
- Load moment of inertia at motor shaft  
 $J_L = J_{L1} + J_B + J_c = 1.25 \times 10^{-4} \text{ (kg}\cdot\text{m}^2\text{)}$

### 6. Load Moving Power

$$P_O = \frac{2\pi n_M \cdot T_L}{60} = \frac{2\pi \times 3,000 \times 0.139}{60} = 43.7 \text{ (W)}$$

### 7. Load Acceleration Power

$$P_a = \left( \frac{2\pi}{60} n_M \right)^2 \frac{J_L}{t_a} = \left( \frac{2\pi}{60} \times 3,000 \right)^2 \times \frac{1.25 \times 10^{-4}}{0.1} = 123.4 \text{ (W)}$$

### 8. Servo Motor Provisional Selection

#### ① Selection Conditions

- $T_L \leq$  Motor rated torque
- $\frac{(P_O + P_a)}{2} <$  Provisionally selected Servo Motor rated output  $< (P_O + P_a)$
- $n_M \leq$  Rated motor speed
- $J_L \leq$  Allowable load moment of inertia

The following Servo Motor meets the selection conditions.

- SGM7J-01A Servo Motor

#### ② Specifications of the Provisionally Selected Servo Motor

Item	Value
Rated Output	100 (W)
Rated Motor Speed	3,000 (min <sup>-1</sup> )
Rated Torque	0.318 (N·m)
Instantaneous Maximum Torque	1.11 (N·m)
Motor Moment of Inertia	0.0659 × 10 <sup>-4</sup> (kg·m <sup>2</sup> )
Allowable Load Moment of Inertia	0.0659 × 10 <sup>-4</sup> × 35 = 2.31 × 10 <sup>-4</sup> (kg·m <sup>2</sup> )
Encoder Resolution	16,777,216 pulses/rev [24 bits]

### 9. Verification of the Provisionally Selected Servo Motor

- Verification of required acceleration torque:

$$T_P = \frac{2\pi n_M (J_M + J_L)}{60ta} + T_L = \frac{2\pi \times 3,000 \times (0.0659 + 1.25) \times 10^{-4}}{60 \times 0.1} + 0.139$$

$$\approx 0.552 \text{ (N}\cdot\text{m)} < \text{Maximum instantaneous torque...Satisfactory}$$

- Verification of required deceleration torque:

$$T_S = \frac{2\pi n_M (J_M + J_L)}{60td} - T_L = \frac{2\pi \times 3,000 \times (0.0659 + 1.25) \times 10^{-4}}{60 \times 0.1} - 0.139$$

$$\approx 0.274 \text{ (N}\cdot\text{m)} < \text{Maximum instantaneous torque...Satisfactory}$$

- Verification of effective torque value:

$$T_{rms} = \sqrt{\frac{T_P^2 \cdot ta + T_L^2 \cdot tc + T_S^2 \cdot td}{t}} = \sqrt{\frac{(0.552)^2 \times 0.1 + (0.139)^2 \times 0.9 + (0.274)^2 \times 0.1}{1.5}}$$

$$\approx 0.192 \text{ (N}\cdot\text{m)} < \text{Rated torque...Satisfactory}$$

It has been verified that the provisionally selected Servo Motor is applicable in terms of capacity. Position control is considered next.

### 10. Positioning Resolution

The electrical stopping precision  $\delta$  is  $\pm 0.01$  mm, so the positioning resolution  $\Delta_\epsilon$  is 0.01 mm.

The ball screw lead  $P_B$  is 0.005 m, so the number of pulses per motor rotation is calculated with the following formula.

$$\text{The number of pulses per revolution (pulses)} = \frac{P_B}{\Delta_\epsilon} = \frac{5 \text{ mm/rev}}{0.01 \text{ mm}} = 500 \text{ (pulses/rev)} < \text{Encoder resolution [16777216 (pulses/rev)]}$$

The number of pulses per motor rotation is less than the encoder resolution (pulses/rev), so the provisionally selected Servo Motor can be used.

### 11. Reference Pulse Frequency

The load speed  $v_L$  is 15 m/min, or  $1,000 \times 15/60$  mm/s and the positioning resolution (travel distance per pulse) is 0.01 mm/pulse, so the reference pulse frequency is calculated with the following formula.

$$v_s = \frac{1,000 v_L}{60 \times \Delta_\epsilon} = \frac{1,000 \times 15}{60 \times 0.01} = 25,000 \text{ (pps)}$$

The reference pulse frequency is less than the maximum input pulse frequency,\* so the provisionally selected Servo Motor can be used.

\*Refer to the specifications in the SERVOPACK manual for the maximum input pulse frequency.

It has been verified that the provisionally selected Servo Motor is applicable for position control.



## Capacity Selection Example for Direct Drive Servo Motors

### 1. Mechanical Specifications

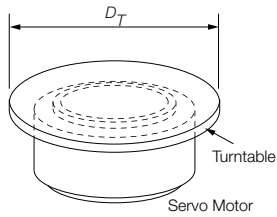

Item	Code	Value	Item	Code	Value
Turntable Mass	$w$	12 kg	Acceleration/ Deceleration Time	$t_p$ $= t_{psa}$ $= t_{psd}$	0.1 s
Turntable Diameter	$D_T$	300 mm	Operating Frequency	$t_f$	2 s
Rotational Angle per Cycle	$\theta$	270 deg	Load Torque	$T_L$	0 N·m
Positioning Time	$t_0$	0.35 s	Settling Time	$t_s$	0.1 s

### 2. Motor Speed of Direct Drive Servo Motor

$$N_O = \frac{\theta}{360} \times \frac{60}{(t_0 - t_p - t_s)} = \frac{270}{360} \times \frac{60}{(0.35 - 0.1 - 0.1)} = 300 \text{ (min}^{-1}\text{)}$$

### 3. Operation Pattern

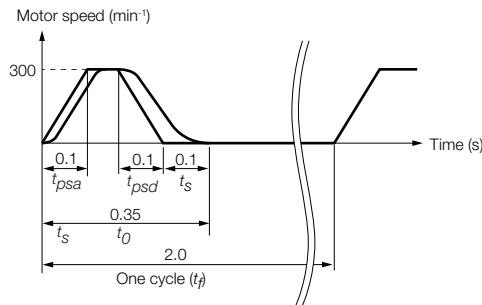

### 4. Load Moment of Inertia

$$J_L = \frac{1}{8} \times D_T^2 \times W = \frac{1}{8} \times (300 \times 10^{-3})^2 \times 12 = 0.135 \text{ (kg}\cdot\text{m}^2\text{)}$$

### 5. Load Acceleration/Deceleration Torque

$$T_a = J_L \times 2\pi \times \frac{N_O/60}{t_p} = 0.135 \times 2\pi \times \frac{300/60}{0.1} = 42.4 \text{ (N}\cdot\text{m)}$$

### 6. Provisional Selection of Direct Drive Servo Motor

#### ① Selection Conditions

- Load acceleration/deceleration torque < Instantaneous maximum torque of Direct Drive Servo Motor
- Load moment of inertia < Allowable load moment of inertia ratio ( $J_R$ ) × Moment of inertia of Direct Drive Servo Motor ( $J_M$ )

The following Servo Motor meets the selection conditions.

- SGMCV-17CEA11

#### ② Specifications of the Provisionally Selected Servo Motor

Item	Value
Rated Torque	17 (N·m)
Instantaneous Maximum Torque	51 (N·m)

## Appendices

### Capacity Selection for Servo Motors

Item	Value
Moment of Inertia ( $J_M$ )	0.00785 (kg·m <sup>2</sup> )
Allowable Load Moment of Inertia Ratio ( $J_R$ )	25

#### 7. Verification of the Provisionally Selected Servo Motor

- Verification of required acceleration torque:

$$T_{Ma} = \frac{(J_L + J_M) \times N_O}{9.55 \times t_{psa}} = \frac{(0.135 + 0.00785) \times 300}{9.55 \times 0.1}$$

$$\approx 44.9 \text{ (N·m)} < \text{Maximum instantaneous torque...Satisfactory}$$

- Verification of required deceleration torque:

$$T_{Md} = -\frac{(J_L + J_M) \times N_O}{9.55 \times t_{psd}} = -\frac{(0.135 + 0.00785) \times 300}{9.55 \times 0.1}$$

$$\approx -44.9 \text{ (N·m)} < \text{Maximum instantaneous torque...Satisfactory}$$

- Verification of effective torque value:

$$T_{rms} = \sqrt{\frac{T_{Ma}^2 \times t_{psa} + T_L^2 \times t_c + T_{Md}^2 \times t_{psd}}{t_f}} = \sqrt{\frac{44.9^2 \times 0.1 + 0^2 \times 0.05 + (-44.9)^2 \times 0.1}{2}}$$

$$\approx 14.2 \text{ (N·m)} < \text{Rated torque...Satisfactory}$$

$$t_c = \text{Time of constant motor speed} = t_0 - t_s - t_{psa} - t_{psd}$$

#### 8. Result

It has been verified that the provisionally selected Servo Motor is applicable.  
The torque diagram is shown below.

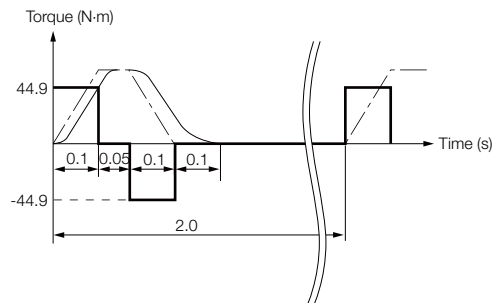

## Servo Motor Capacity Selection Example for Linear Servo Motors

### 1. Mechanical Specifications

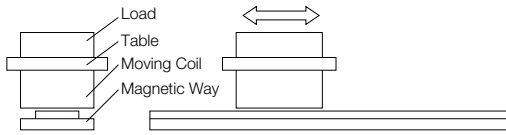

Item	Code	Value
Load Mass	$m_W$	1 kg
Table Mass	$m_T$	2 kg
Motor Speed	$v$	2 m/s
Feeding Distance	$l$	0.76 m
Friction Coefficient	$\mu$	0.2

Item	Code	Value
Acceleration Time	$t_a$	0.02 s
Constant-speed Time	$t_c$	0.36 s
Deceleration Time	$t_d$	0.02 s
Cycle Time	$t$	0.5 s
External Force on Linear Motion Section	$F$	0 N

### 2. Operation Pattern

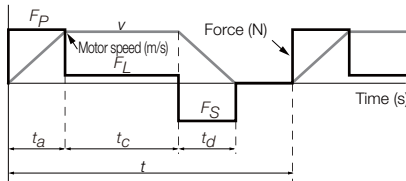

### 3. Steady-State Force (Excluding Servo Motor Moving Coil)

$$F_L = \{9.8 \times \mu \times (m_W + m_T)\} + F = 9.8 \times 0.2 \times (1 + 2) + 0 = 5.88 \text{ (N)}$$

### 4. Acceleration Force (Excluding Servo Motor Moving Coil)

$$F_P = (m_W + m_T) \times \frac{v}{t_a} + F_L = (1 + 2) \times \frac{2}{0.02} + 5.88 = 305.88 \text{ (N)}$$

### 5. Provisional Selection of Linear Servo Motor

#### ① Selection Conditions

- $F_P \leq \text{Maximum force} \times 0.9$
- $F_S \leq \text{Maximum force} \times 0.9$
- $F_{rms} \leq \text{Rated force} \times 0.9$

The following Servo Motor Moving Coil and Magnetic Way meet the selection conditions.

- SGLGW-60A253CP Linear Servo Motor Moving Coil
- SGLGM-60□□□□ Linear Servo Motor Magnetic Way

#### ② Specifications of the Provisionally Selected Servo Motor

Item	Value
Maximum Force	440 (N)
Rated Force	140 (N)
Moving Coil Mass ( $m_M$ )	0.82 (kg)
Servo Motor Magnetic Attraction ( $F_{att}$ )	0 (N)

**6. Verification of the Provisionally Selected Servo Motor**

- Steady-State Force

$$F_L = \mu \{9.8 \times (m_W + m_T + m_M) + F_{att}\} = 0.2 \{9.8 \times (1 + 2 + 0.82) + 0\} = 7.5 \text{ (N)}$$

- Verification of Acceleration Force

$$F_P = (m_W + m_T + m_M) \times \frac{v}{t_a} + F_L = (1 + 2 + 0.82) \times \frac{2}{0.02} + 7.5$$

$$= 389.5 \text{ (N)} \leq \text{Maximum force} \times 0.9 (= 396 \text{ N}) \dots \text{Satisfactory}$$

- Verification of Deceleration Force

$$F_S = (m_W + m_T + m_M) \times \frac{v}{t_a} - F_L = (1 + 2 + 0.82) \times \frac{2}{0.02} - 7.5$$

$$= 374.5 \text{ (N)} \leq \text{Maximum force} \times 0.9 (= 396 \text{ N}) \dots \text{Satisfactory}$$

- Verification of Effective Force

$$F_{rms} = \sqrt{\frac{F_P^2 \cdot t_a + F_L^2 \cdot t_c + F_S^2 \cdot t_d}{t}} = \sqrt{\frac{389.5^2 \times 0.02 + 7.5^2 \times 0.36 + 374.5^2 \times 0.02}{0.5}}$$

$$= 108.3 \text{ (N)} \leq \text{Rated force} \times 0.9 (= 132.3 \text{ N}) \dots \text{Satisfactory}$$

**7. Result**

It has been verified that the provisionally selected Servo Motor is applicable.



# Capacity Selection for Regenerative Resistors

If the regenerative power exceeds the amount that can be absorbed by charging the smoothing capacitor, a regenerative resistor is used.

## Regenerative Power and Regenerative Resistance

The rotational energy of a driven machine such as a Servo Motor that is returned to the SERVOPACK is called regenerative power. The regenerative power is absorbed by charging a smoothing capacitor. When the regenerative power exceeds the capacity of the capacitor, it is consumed by a regenerative resistor. (This is called resistance regeneration.)

The Servo Motor is driven in a regeneration state in the following circumstances:

- While decelerating to a stop during acceleration/deceleration operation.
- While performing continuous downward operation on a vertical axis.
- During continuous operation in which the Servo Motor is rotated by the load (i.e., a negative load).



Important

You cannot use the resistance regeneration provided by the SERVOPACK for continuous regeneration. For continuous operation with a negative load, you must design a system that also includes a Power Regenerative Converter or Power Regenerative Unit (for example, Yaskawa model D1000 or R1000). If regenerative power is not appropriately processed, the regenerative energy from the load will exceed the allowable range and damage the SERVOPACK. Examples of negative loads are shown below.

- Motor Drive to Lower Objects without a Counterweight
- Motor Drive for Feeding

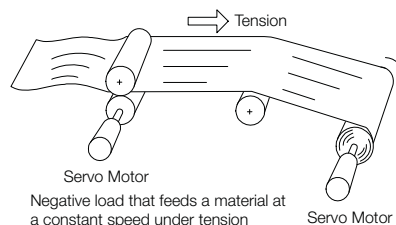
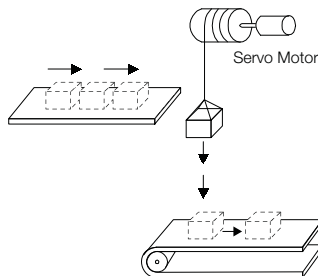

## Types of Regenerative Resistors

The following regenerative resistors can be used.

- Built-in regenerative resistor: A regenerative resistor that is built into the SERVOPACK. Not all SERVOPACKs have built-in regenerative resistors.
- External Regenerative Resistor: A regenerative resistor that is connected externally to a SERVOPACK. These resistors are used when the smoothing capacitor and built-in regenerative resistor in the SERVOPACK cannot consume all of the regenerative power.

SERVOPACK Model		Built-In Regenerative Resistor	External Regenerative Resistor
SGD7S-	R70A, R90A, 1R6A, 2R8A	None	Basically not required
	3R8A, 5R5A, 7R6A, 120A, 180A, 200A, 330A	Standard feature <sup>*1</sup>	Basically not required
	470A, 550A, 590A, 780A	None	Required <sup>*2</sup>
SGD7W-	1R6A, 2R8A, 5R5A, 7R6A	Standard feature <sup>*1</sup>	Basically not required

<sup>\*1</sup>. Refer to the following section for the specifications of the regenerative resistors built into SERVOPACKs.

Built-In Regenerative Resistor (page 385)

<sup>\*2</sup>. An optional external Regenerative Resistor Unit is required.

## Selecting External Regenerative Resistor

Use Yaskawa's SigmaJunmaSize+, an AC servo drive capacity selection program, to determine if you need an External Regenerative Resistor.

You can use one of the following two methods to manually calculate whether an External Regenerative Resistor is required. Refer to the following information if you do not use the SigmaJunmaSize+.

 [Simple Calculation \(page 403\)](#)

 [Calculating the Regenerative Energy \(page 408\)](#)

### Simple Calculation

When driving a Servo Motor with a horizontal shaft, check if an External Regenerative Resistor is required using the following calculation method. The calculation method depends on the model of the SERVOPACK.

#### ◆ SERVOPACK Models SGD7S-R70A, -R90A, -1R6A, and -2R8A

Regenerative resistors are not built into the above SERVOPACKs. The total amount of energy that can be charged in the capacitors is given in the following table.

If the rotational energy ( $E_S$ ) of the Servo Motor and load exceeds the processable regenerative energy, then connect an External Regenerative Resistor.

Applicable SERVOPACK		Processable Regenerative Energy (Joules)	Remarks
SGD7S-	R70A, R90A, 1R6A	24.2	Value when main circuit input voltage is 200 VAC
	2R8A	31.7	

Calculate the rotational energy ( $E_S$ ) of the servo system with the following equation:

$$E_S = J \times (n_M)^2 / 182 \text{ (Joules)}$$

- $J = J_M + J_L$
- $J_M$ : Servo Motor moment of inertia ( $\text{kg}\cdot\text{m}^2$ )
- $J_L$ : Load moment of inertia at motor shaft ( $\text{kg}\cdot\text{m}^2$ )
- $n_M$ : Servo Motor operating motor speed ( $\text{min}^{-1}$ )

## Appendices

### Capacity Selection for Regenerative Resistors

- ◆ SERVOPACK Models SGD7S-3R8A, -5R5A, -7R6A, -120A, -180A, -200A, -330A, -470A, -550A, -590A, and -780A; SGD7W-1R6A, -2R8A, -5R5A, and -7R6A

These SERVOPACKs have built-in regenerative resistors. The allowable frequencies for regenerative operation of the Servo Motor without a load in acceleration/deceleration operation during an operation cycle from 0 ( $\text{min}^{-1}$ ) to the maximum motor speed and back to 0, are listed in the following table. Convert the data into the values for the actual motor speed and load moment of inertia to determine whether an External Regenerative Resistor is required.

#### ■ Rotary Servo Motors

Servo Motor Model		Allowable Frequencies in Regenerative Operation (Operations/Min)	
		SERVOPACK Model: SGD7S	SERVOPACK Model: SGD7W (Simultaneous Operation of Two Axes)
SGM7J-	A5A	–	300
	01A	–	180
	C2A	–	130
	02A	–	46
	04A	–	25
	06A	30	30
	08A	15	15
SGM7A-	A5A	–	560
	01A	–	360
	C2A	–	260
	02A	–	87
	04A	–	56
	06A	77	77
	08A	31	31
	10A	31	–
	15A	15	–
	20A	19	–
	25A	15	–
	30A	6.9	–
	40A	11	–
	50A	8.8	–
	70A	86	–

Servo Motor Model		Allowable Frequencies in Regenerative Operation (Operations/Min)	
		SERVOPACK Model: SGD7S	SERVOPACK Model: SGD7W (Simultaneous Operation of Two Axes)
SGM7P-	01A	–	200
	C2A	–	46
	04A	–	29
	08A	11	11
	15A	7.5	–
	03A	39	39
SGM7G-	05A	29	29
	09A	6.9	6.9
	13A	6.1	–
	20A	7.4	–
	30A	9.5	–
	44A	6.4	–
	55A	24	–
	75A	34	–
	1AA	39	–
1EA	31	–	



■ Direct Drive Servo Motors

Servo Motor Model		Allowable Frequencies in Regenerative Operation (Operations/Min)	
		SERVOPACK Model: SGD7S	SERVOPACK Model: SGD7W (Simultaneous Operation of Two Axes)
SGMCS-	02B	–	62
	05B	–	34
	07B	–	22
	04C	–	22
	08D	–	6.1
	10C	–	19
	14C	–	22
	17D	–	7
	25D	–	9.3
	16E	3.7	3.7
	35E	9.7	9.7
	45M	25	25
	80M	19	–
	80N	8.9	–
	1AM	22	–
	1EN	11	–
2ZN	9.1	–	

## Appendices

### Capacity Selection for Regenerative Resistors

#### ■ Linear Servo Motors

Servo Motor Model		Allowable Frequencies in Regenerative Operation (Operations/Min)	
		SERVOPACK Model: SGD7S	SERVOPACK Model: SGD7W (Simultaneous Operation of Two Axes)
SGLGW- Using a Standard-Force Magnetic Way	30A050C	–	190
	30A080C	–	120
	40A140C	–	56
	40A253C	–	32
	40A365C	–	22
	60A140C	–	49
	60A253C	–	27
	60A365C	37	37
	90A200C	34	–
	90A370C	33	–
SGLGW- Using a High-Force Magnetic Way	90A535C	24	–
	40A140C	–	80
	40A253C	–	45
	40A365C	62	62
	60A140C	–	64
	60A253C	71	71
SGLFW-	60A365C	49	49
	20A090A	–	27
	20A120A	–	21
	35A120A	–	14
	35A230A	16	16
	50A200B	10	10
	50A380B	6.9	–
	1ZA200B	7.8	–
SGLTW-	1ZA380B	6.6	–
	20A170A	15	15
	20A320A	8.3	8.3
	20A460A	7.1	–
	35A170A	10	10
	35A170H	8.5	8.5
	35A320A	7	–
	35A320H	5.9	–
	35A460A	7.6	–
	40A400B	13	–
	40A600B	19	–
	50A170H	15	15
	50A320H	11	–
	80A400B	28	–
80A600B	180	–	

\*1. This value is in combination with the SGD7S-120A.

\*2. This value is in combination with the SGD7S-180A

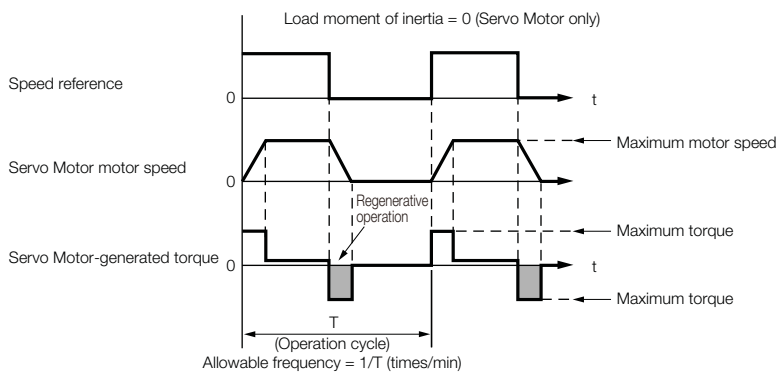

Operating Conditions for Calculating the Allowable Regenerative Frequency

Use the following equation to calculate the allowable frequency for regenerative operation.

$$\text{Allowable frequency} = \frac{\text{Allowable frequency for regenerative operation for Servo Motor without load}}{(1+n)} \times \left( \frac{\text{Maximum motor speed}}{\text{Operating motor speed}} \right)^2 \text{ (time/min)}$$

- $n = J_L/J_M$
- $J_M$ : Servo Motor moment of inertia (kg·m<sup>2</sup>)
- $J_L$ : Load moment of inertia at motor shaft (kg·m<sup>2</sup>)

## Calculating the Regenerative Energy

This section shows how to calculate the regenerative resistor capacity for the acceleration/deceleration operation shown in the following figure.

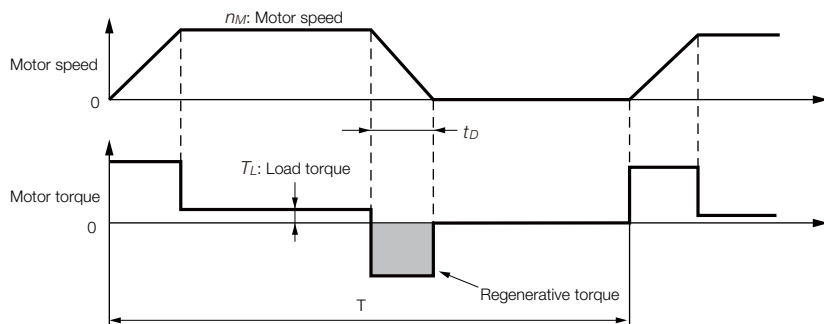

### • Calculation Procedure for Regenerative Resistor Capacity

Step	Item	Code	Formula
1	Calculate the rotational energy of the Servo Motor.	$E_S$	$E_S = Jn_M^2/182$
2	Calculate the energy consumed by load loss during the deceleration period	$E_L$	$E_L = (\pi/60) n_M T_L t_D$ Note: If the load loss is unknown, calculate the value with $E_L$ set to 0.
3	Calculate the energy lost from Servo Motor winding resistance.	$E_M$	(Value calculated from the graphs in <b>◆ Servo Motor Winding Resistance Loss</b> on page 411) $\times t_D$
4	Calculate the energy that can be absorbed by the SERVOPACK.	$E_C$	Calculate from the graphs in <b>◆ SERVOPACK-absorbable Energy</b> on page 409
5	Calculate the energy consumed by the regenerative resistor.	$E_K$	$E_K = E_S - (E_L + E_M + E_C)$ $E_K = E_S - (E_L + E_M + E_C) + E_G^*$ Note: Use this formula if there will be continuous periods of regenerative operation, such as for a vertical axis.
6	Calculate the required regenerative resistor capacity (W).	$W_K$	$W_K = E_K/(0.2 \times T)$

\*  $E_G$  (joules): Energy for continuous period of regenerative operation

$$E_G = (2\pi/60) n_{MG} T_G t_G$$

- $T_G$ : Servo Motor's generated torque in continuous period of regenerative operation (N·m)
- $n_{MG}$ : Servo Motor's motor speed for same operation period as above ( $\text{min}^{-1}$ )
- $t_G$ : Same operation period as above (s)

Note: 1. The 0.2 in the equation for calculating  $W_K$  is the value when the regenerative resistor's utilized load ratio is 20%.

2. The units for the various symbols are given in the following table.

Code	Description
$E_S$ to $E_K$	Energy in joules (J)
$W_K$	Required regenerative resistor capacity (W)
$J$	$= J_M + J_L$ ( $\text{kg} \cdot \text{m}^2$ )
$n_M$	Servo Motor motor speed ( $\text{min}^{-1}$ )

Code	Description
$T_L$	Load torque (N·m)
$t_D$	Deceleration stopping time (s)
$T$	Servo Motor repeat operation cycle (s)

If the value of  $W_K$  does not exceed the capacity of the built-in regenerative resistor of the SERVOPACK, an External Regenerative Resistor is not required. For details on the built-in regenerative resistors, refer to the SERVOPACK specifications. If the value of  $W_K$  exceeds the capacity of the built-in regenerative resistor, install an External Regenerative Resistor with a capacity equal to the value for  $W$  calculated above.

◆ SERVOPACK-absorbable Energy

The following figures show the relationship between the SERVOPACK's input power supply voltage and its absorbable energy.

■ Σ-7S SERVOPACKs

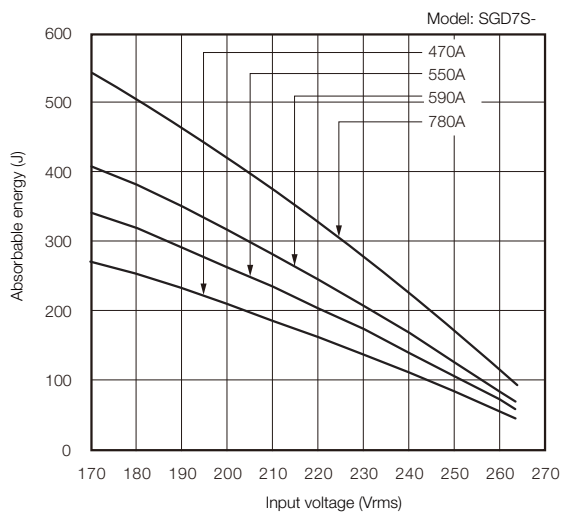
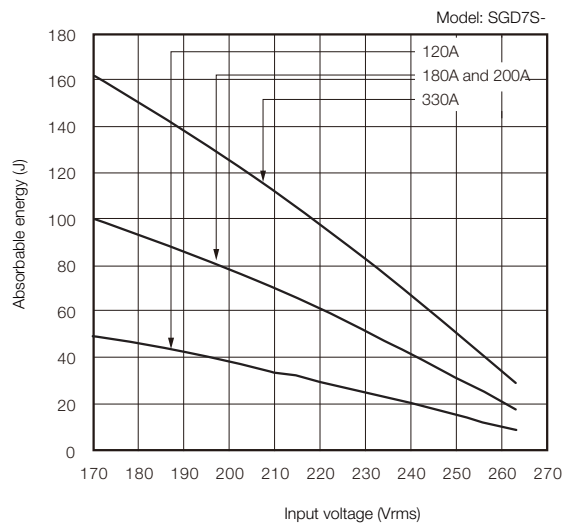
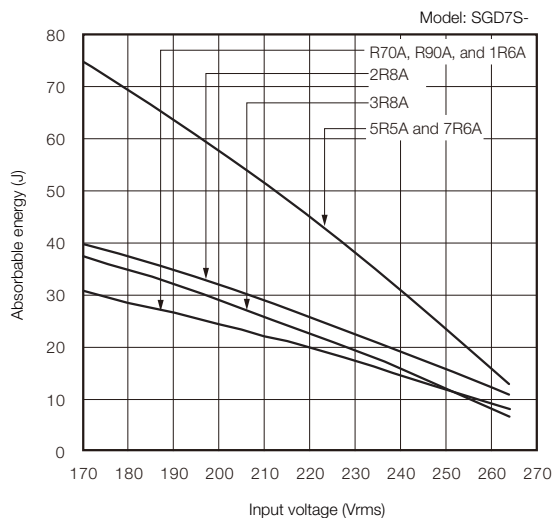

## Appendices

### Capacity Selection for Regenerative Resistors

#### ■ $\Sigma$ -7W SERVOPACKs

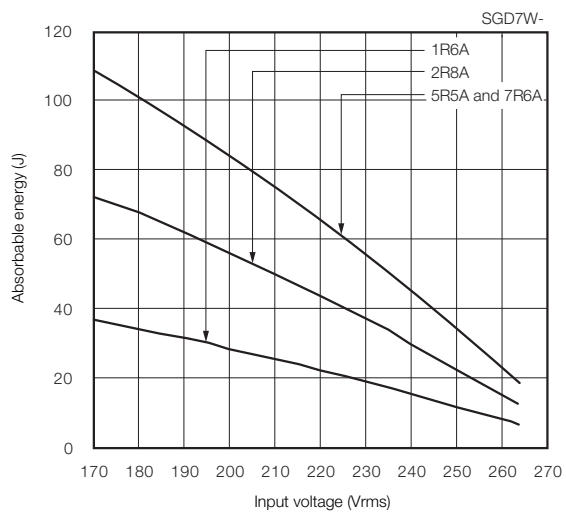

### ◆ Servo Motor Winding Resistance Loss

The following figures show the relationship for each Servo Motor between the Servo Motor's generated torque and the winding resistance loss.

#### ■ SGM7J Rotary Servo Motors

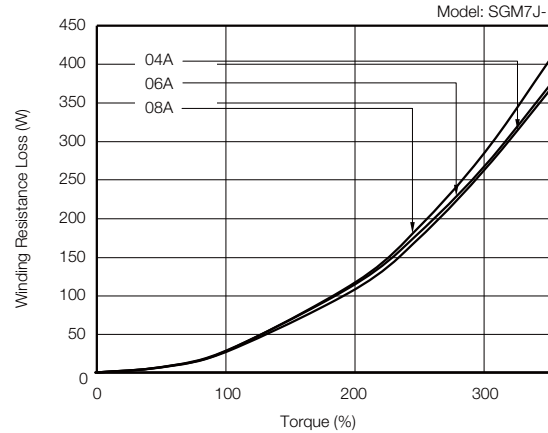
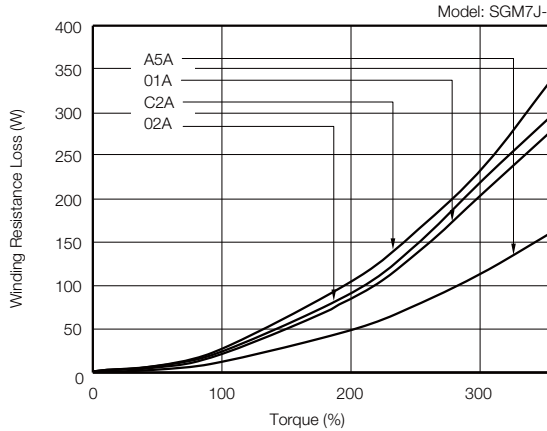

#### ■ SGM7A Rotary Servo Motors

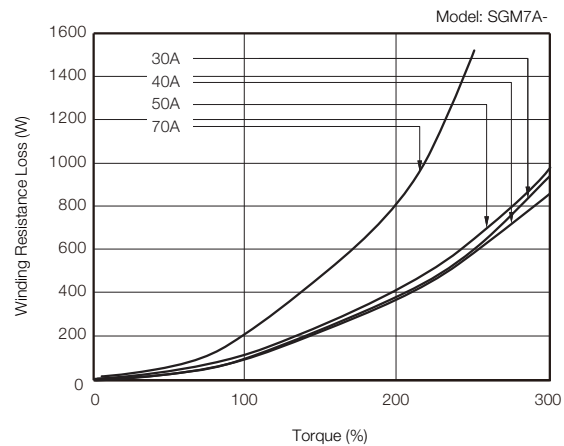
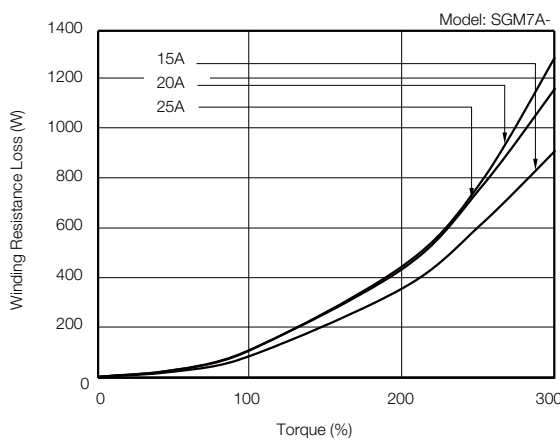
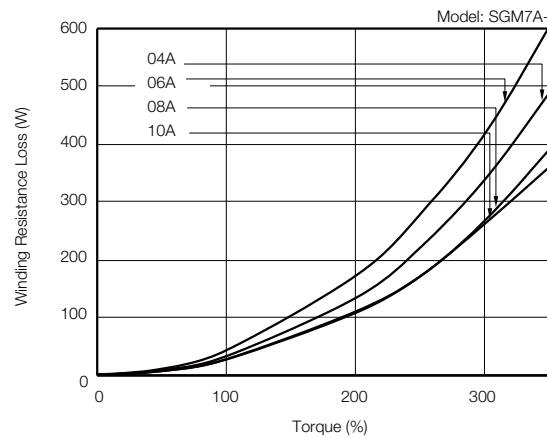
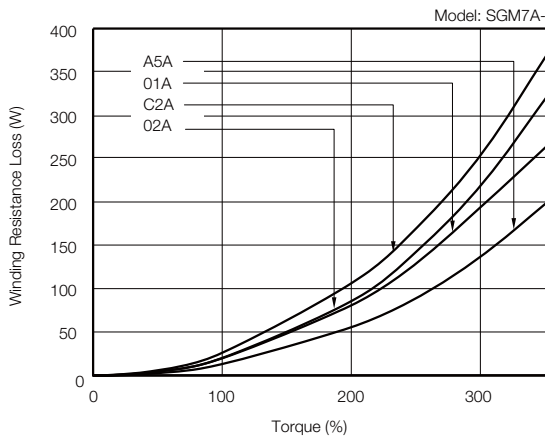

## Appendices

### Capacity Selection for Regenerative Resistors

#### SGM7P Rotary Servo Motors

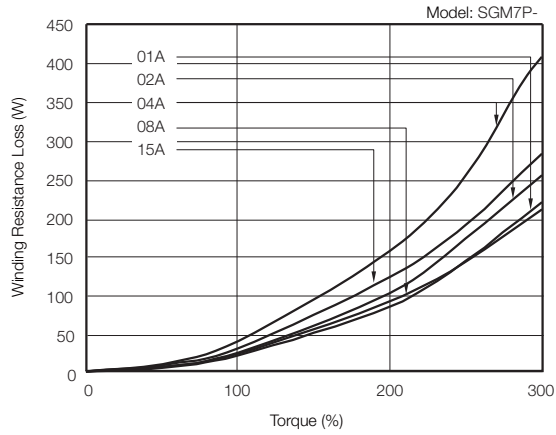

#### SGM7G Rotary Servo Motors

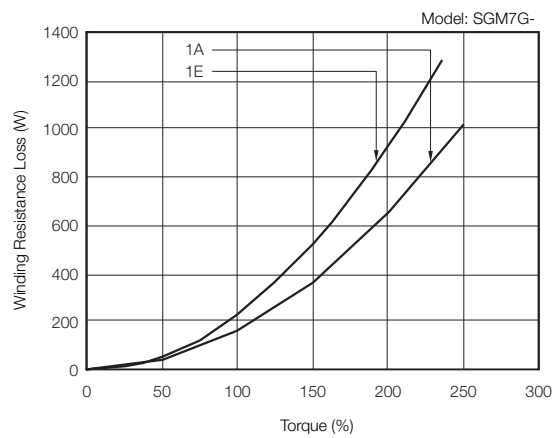
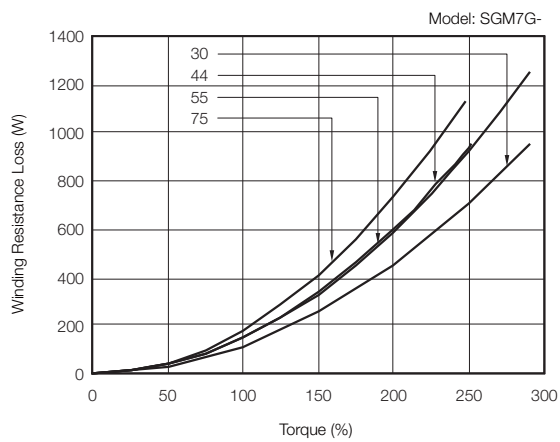
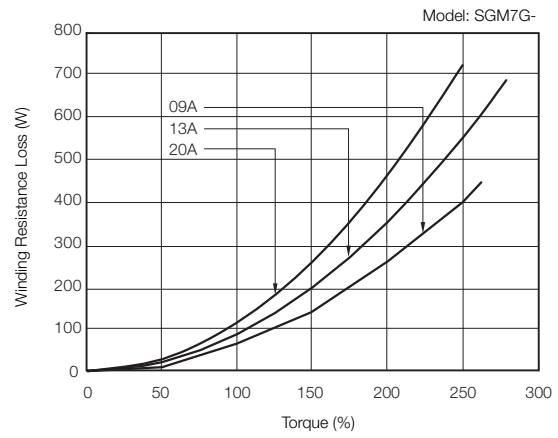
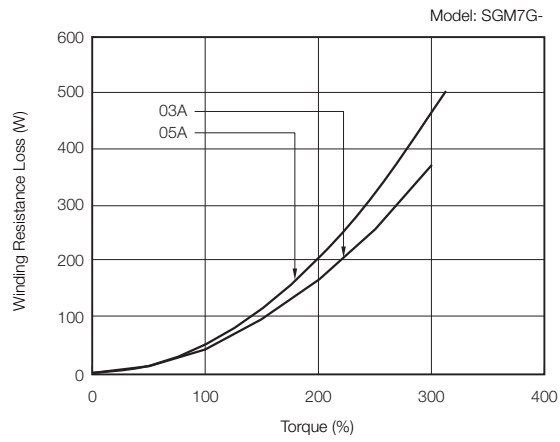



■ SGMCS Direct Drive Servo Motors

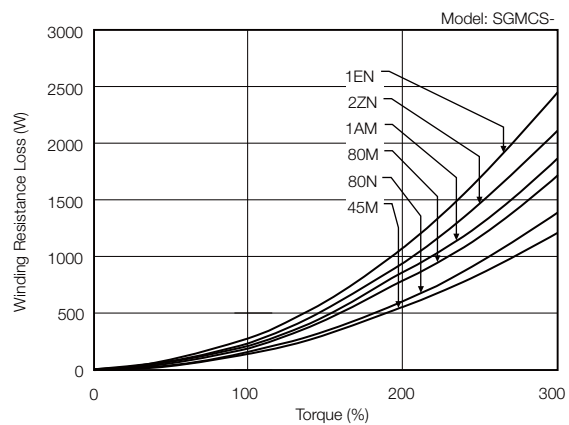
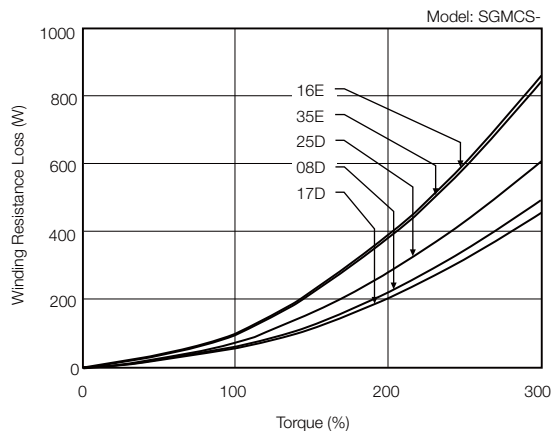
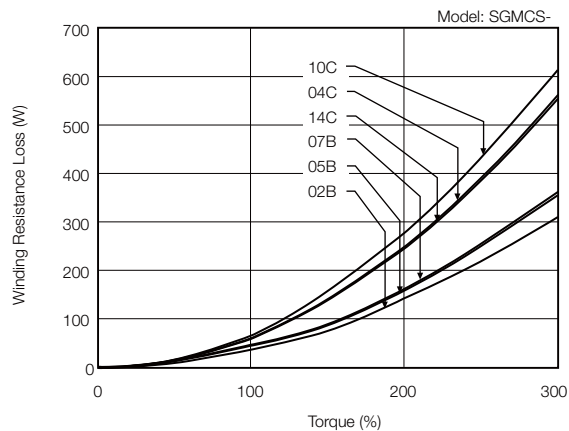

## Appendices

### Capacity Selection for Regenerative Resistors

#### ■ SGLGW Linear Servo Motors

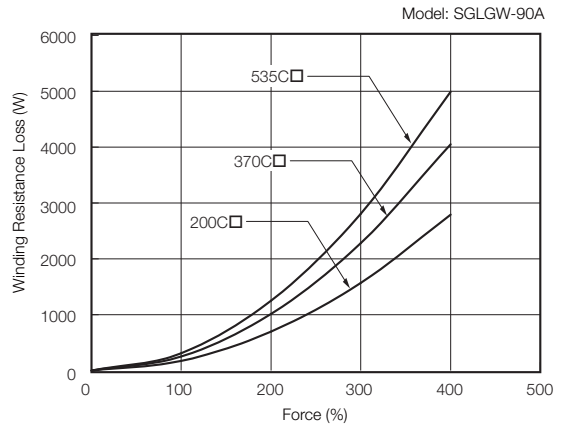
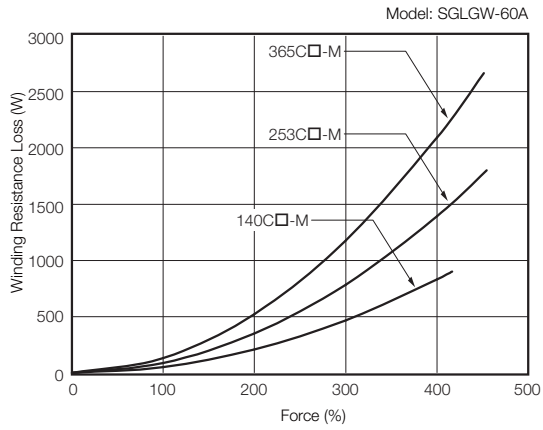
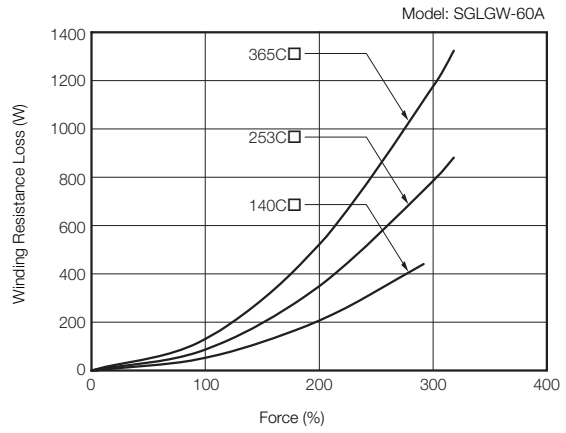
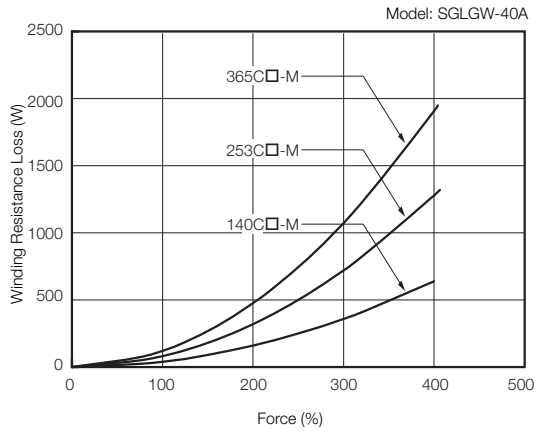
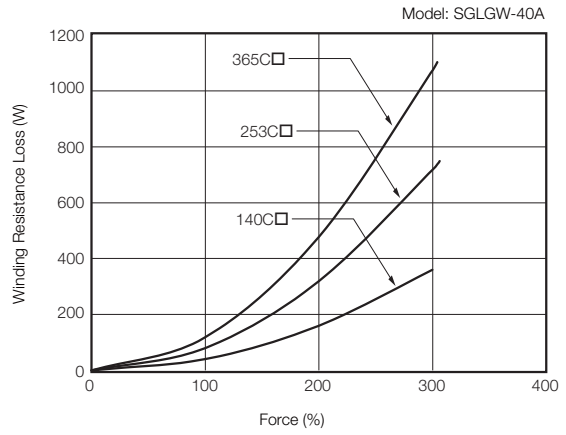
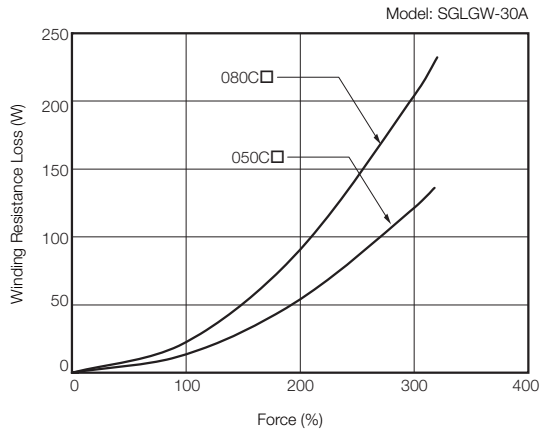

■ SGLFW Linear Servo Motors

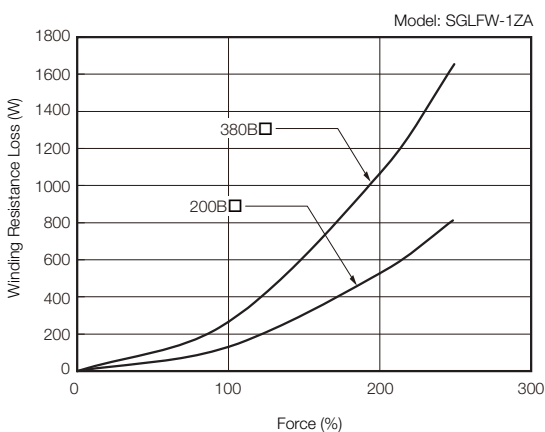
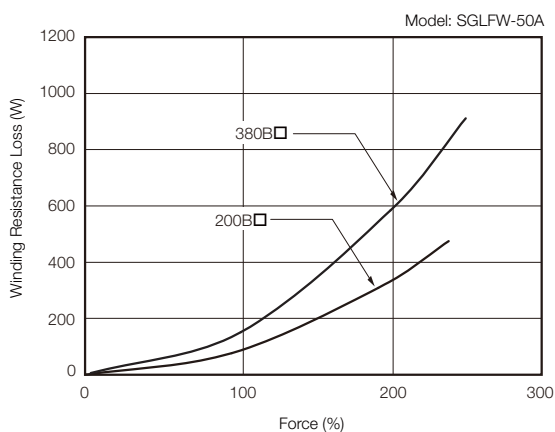
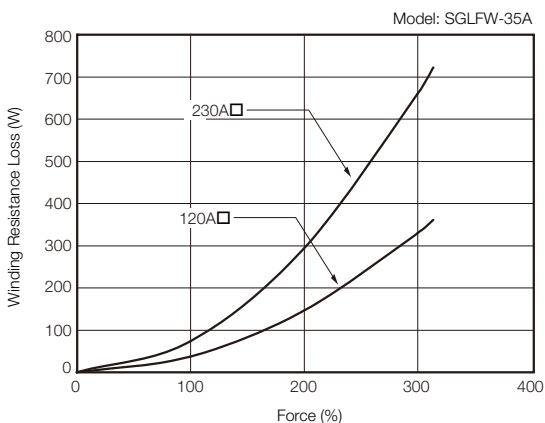
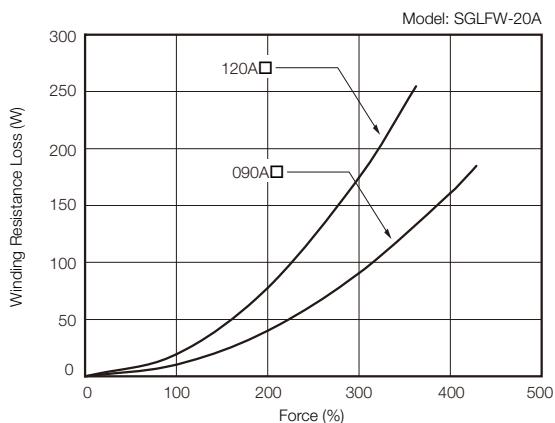

## Appendices

### Capacity Selection for Regenerative Resistors

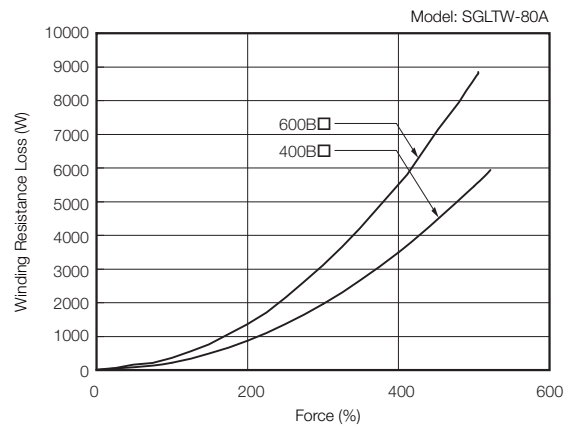
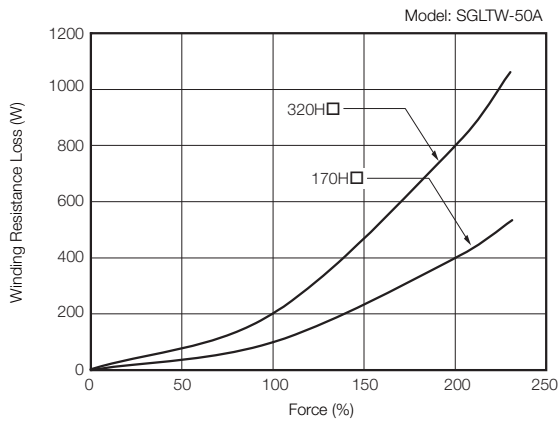
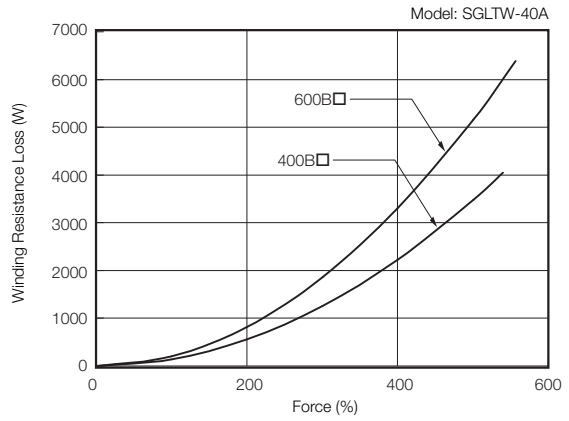
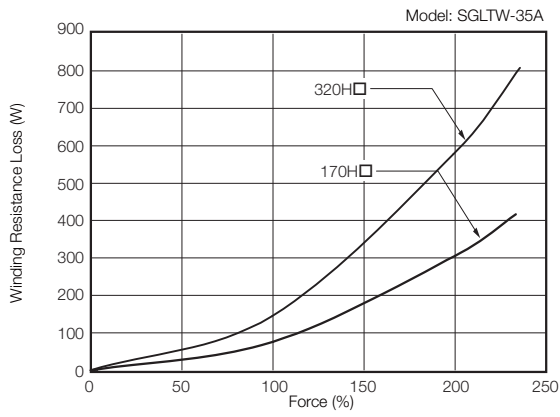
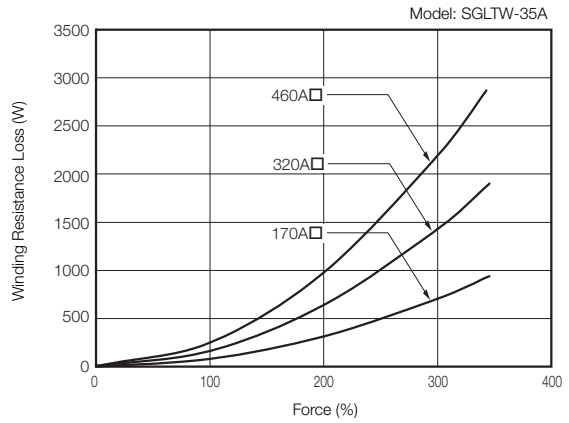
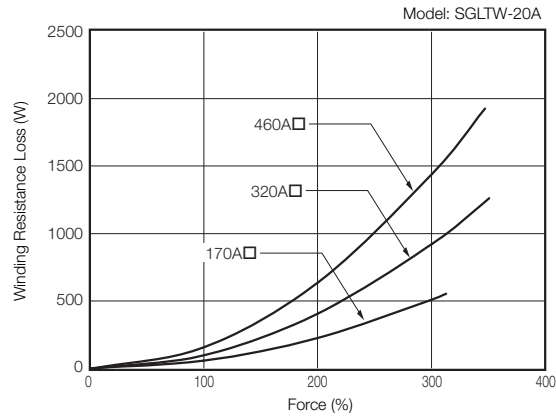

#### ■ SGLTW Linear Servo Motors







# International Standards

●: Certified, – : Not Certified

Product	Model	UL/CSA Standards	CE Marking	KC Mark	RoHS Directive
					
SERVOPACKs	SGD7S	●	●	●	●
	SGD7W	●	●	●	●
Feedback Option	Fully-Closed Module	SGDV-OFA01A <sup>*1</sup>	●	●	●
Safety Option	Safety Module	SGDV-OSA01A <sup>*1</sup>	●	●	●

Product	Model	UL/CSA Standards	CE Marking	RoHS Directive
				
Rotary Servo Motors	SGM7J	●	●	●
	SGM7A	●	●	●
	SGM7P	●	●	●
	SGM7G	●	●	●
Direct Drive Servo Motors	SGMCS	●	*3	● <sup>*2</sup>
Linear Servo Motors	SGLGW (SGLGM) <sup>*4</sup>	●	*5	●
	SGLFW (SGLFM) <sup>*4</sup>	●	*5	●
	SGLTW (SGLTM) <sup>*4</sup>	●	*5	●

\*1. Use this model number to purchase the Option Module separately.

\*2. Estimates are provided for RoHS-compliant products. The model numbers have an “-E” suffix.

\*3. CE Marking certification has not yet been received for SGMCS-**□□M** and SGMCS-**□□N** Direct Drive Servo Motors. CE Marking certification has been received for the following Direct Drive Servo Motors: SGMCS-**□□B**, SGMCS-**□□C**, SGMCS-**□□D**, and SGMCS-**□□E**. Contact your Yaskawa representative if the CE Marking label is required.

\*4. The model numbers of the Magnetic Ways of Linear Servo Motors are given in parentheses.

\*5. CE Marking certification has been received. Contact your Yaskawa representative if the CE Marking label is required.



# Warranty

## ◆ Details of Warranty

### ■ Warranty Period

The warranty period for a product that was purchased (hereinafter called the “delivered product”) is one year from the time of delivery to the location specified by the customer or 18 months from the time of shipment from the Yaskawa factory, whichever is sooner.

### ■ Warranty Scope

Yaskawa shall replace or repair a defective product free of charge if a defect attributable to Yaskawa occurs during the above warranty period.

This warranty does not cover defects caused by the delivered product reaching the end of its service life and replacement of parts that require replacement or that have a limited service life.

This warranty does not cover failures that result from any of the following causes.

- Improper handling, abuse, or use in unsuitable conditions or in environments not described in product catalogs or manuals, or in any separately agreed-upon specifications
- Causes not attributable to the delivered product itself
- Modifications or repairs not performed by Yaskawa
- Use of the delivered product in a manner in which it was not originally intended
- Causes that were not foreseeable with the scientific and technological understanding at the time of shipment from Yaskawa
- Events for which Yaskawa is not responsible, such as natural or human-made disasters

## ◆ Limitations of Liability

- Yaskawa shall in no event be responsible for any damage or loss of opportunity to the customer that arises due to failure of the delivered product.
- Yaskawa shall not be responsible for any programs (including parameter settings) or the results of program execution of the programs provided by the user or by a third party for use with programmable Yaskawa products.
- The information described in product catalogs or manuals is provided for the purpose of the customer purchasing the appropriate product for the intended application. The use thereof does not guarantee that there are no infringements of intellectual property rights or other proprietary rights of Yaskawa or third parties, nor does it construe a license.
- Yaskawa shall not be responsible for any damage arising from infringements of intellectual property rights or other proprietary rights of third parties as a result of using the information described in catalogs or manuals.



### ◆ Suitability for Use

- It is the customer's responsibility to confirm conformity with any standards, codes, or regulations that apply if the Yaskawa product is used in combination with any other products.
- The customer must confirm that the Yaskawa product is suitable for the systems, machines, and equipment used by the customer.
- Consult with Yaskawa to determine whether use in the following applications is acceptable. If use in the application is acceptable, use the product with extra allowance in ratings and specifications, and provide safety measures to minimize hazards in the event of failure.
  - Outdoor use, use involving potential chemical contamination or electrical interference, or use in conditions or environments not described in product catalogs or manuals
  - Nuclear energy control systems, combustion systems, railroad systems, aviation systems, vehicle systems, medical equipment, amusement machines, and installations subject to separate industry or government regulations
  - Systems, machines, and equipment that may present a risk to life or property
  - Systems that require a high degree of reliability, such as systems that supply gas, water, or electricity, or systems that operate continuously 24 hours a day
  - Other systems that require a similar high degree of safety
- Never use the product for an application involving serious risk to life or property without first ensuring that the system is designed to secure the required level of safety with risk warnings and redundancy, and that the Yaskawa product is properly rated and installed.
- The circuit examples and other application examples described in product catalogs and manuals are for reference. Check the functionality and safety of the actual devices and equipment to be used before using the product.
- Read and understand all use prohibitions and precautions, and operate the Yaskawa product correctly to prevent accidental harm to third parties.

### ◆ Specifications Change

The names, specifications, appearance, and accessories of products in product catalogs and manuals may be changed at any time based on improvements and other reasons. The next editions of the revised catalogs or manuals will be published with updated code numbers. Consult with your Yaskawa representative to confirm the actual specifications before purchasing a product.

# Warranty

## ◆ Details of Warranty

### ■ Warranty Period

The warranty period for a product that was purchased (hereinafter called the “delivered product”) is one year from the time of delivery to the location specified by the customer or 18 months from the time of shipment from the Yaskawa factory, whichever is sooner.

### ■ Warranty Scope

Yaskawa shall replace or repair a defective product free of charge if a defect attributable to Yaskawa occurs during the above warranty period.

This warranty does not cover defects caused by the delivered product reaching the end of its service life and replacement of parts that require replacement or that have a limited service life.

This warranty does not cover failures that result from any of the following causes.

- Improper handling, abuse, or use in unsuitable conditions or in environments not described in product catalogs or manuals, or in any separately agreed-upon specifications
- Causes not attributable to the delivered product itself
- Modifications or repairs not performed by Yaskawa
- Use of the delivered product in a manner in which it was not originally intended
- Causes that were not foreseeable with the scientific and technological understanding at the time of shipment from Yaskawa
- Events for which Yaskawa is not responsible, such as natural or human-made disasters

## ◆ Limitations of Liability

- Yaskawa shall in no event be responsible for any damage or loss of opportunity to the customer that arises due to failure of the delivered product.
- Yaskawa shall not be responsible for any programs (including parameter settings) or the results of program execution of the programs provided by the user or by a third party for use with programmable Yaskawa products.
- The information described in product catalogs or manuals is provided for the purpose of the customer purchasing the appropriate product for the intended application. The use thereof does not guarantee that there are no infringements of intellectual property rights or other proprietary rights of Yaskawa or third parties, nor does it construe a license.
- Yaskawa shall not be responsible for any damage arising from infringements of intellectual property rights or other proprietary rights of third parties as a result of using the information described in catalogs or manuals.

### ◆ Suitability for Use

- It is the customer's responsibility to confirm conformity with any standards, codes, or regulations that apply if the Yaskawa product is used in combination with any other products.
- The customer must confirm that the Yaskawa product is suitable for the systems, machines, and equipment used by the customer.
- Consult with Yaskawa to determine whether use in the following applications is acceptable. If use in the application is acceptable, use the product with extra allowance in ratings and specifications, and provide safety measures to minimize hazards in the event of failure.
  - Outdoor use, use involving potential chemical contamination or electrical interference, or use in conditions or environments not described in product catalogs or manuals
  - Nuclear energy control systems, combustion systems, railroad systems, aviation systems, vehicle systems, medical equipment, amusement machines, and installations subject to separate industry or government regulations
  - Systems, machines, and equipment that may present a risk to life or property
  - Systems that require a high degree of reliability, such as systems that supply gas, water, or electricity, or systems that operate continuously 24 hours a day
  - Other systems that require a similar high degree of safety
- Never use the product for an application involving serious risk to life or property without first ensuring that the system is designed to secure the required level of safety with risk warnings and redundancy, and that the Yaskawa product is properly rated and installed.
- The circuit examples and other application examples described in product catalogs and manuals are for reference. Check the functionality and safety of the actual devices and equipment to be used before using the product.
- Read and understand all use prohibitions and precautions, and operate the Yaskawa product correctly to prevent accidental harm to third parties.

### ◆ Specifications Change

The names, specifications, appearance, and accessories of products in product catalogs and manuals may be changed at any time based on improvements and other reasons. The next editions of the revised catalogs or manuals will be published with updated code numbers. Consult with your Yaskawa representative to confirm the actual specifications before purchasing a product.







Yaskawa is the leading global manufacturer of low and medium voltage inverter drives, servo drives, machine controllers, and industrial robots.

Our standard products, as well as tailor-made solutions, are well known and have a high reputation for outstanding quality and reliability.

# YASKAWA