

# YASKAWA AC Drive L1000A

for Elevator Applications

200 V Class 1.5 to 110 kW

400 V Class 1.5 to 110 kW



The Lift Drive

Certified for  
ISO9001 and  
ISO14001



JQA-0422

JQA-EM0498

# 1. Matching Every Need

## Runs Induction and Synchronous Motors

■ Cutting-edge drive technology allows L1000 to run a newly installed gearless synchronous motor, or a refurbished geared induction motor. This minimizes equipment required for your application.

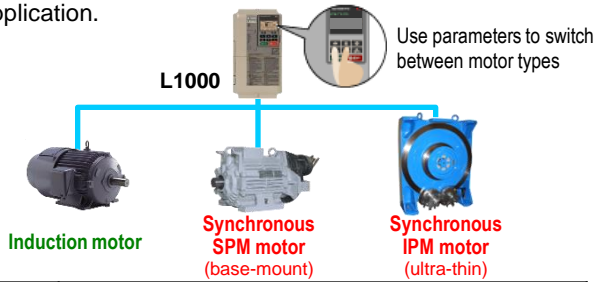

Capacity Range	200 V Class 1.5 to 110kW 400 V Class 1.5 to 110kW				
Control Mode	<table border="0"> <tr> <td>PM motors</td> <td>• Closed Loop Vector Control for PM motors (SPM/IPM drive)</td> </tr> <tr> <td>Induction motors</td> <td>• V/f Control • Open Loop Vector Control • Closed Loop Vector Control</td> </tr> </table>	PM motors	• Closed Loop Vector Control for PM motors (SPM/IPM drive)	Induction motors	• V/f Control • Open Loop Vector Control • Closed Loop Vector Control
PM motors	• Closed Loop Vector Control for PM motors (SPM/IPM drive)				
Induction motors	• V/f Control • Open Loop Vector Control • Closed Loop Vector Control				

## Designed Compact for Tight Machine Rooms

- Easily fit into compact machine rooms by combining the world's smallest drive in its class with the light, efficient design of a PM motor.
- L1000's slender design can be installed into a slender control panel. Depth of 200 mm for models up to 18.5 kW, 300 mm for 22 kW to 75kW
- Take advantage of Side-by-Side installation\* when storage space is limited. \* For models up to 18.5 kW.

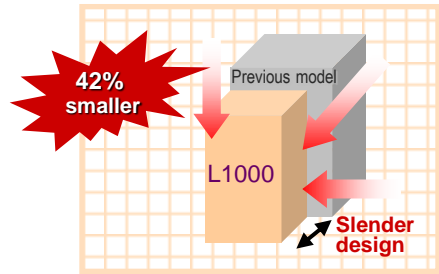

● Drive Dimension Comparison  
Example shows a 400 V Class, 15 kW drive

## Compatible with a Wide Range of Encoders

- High-performance current vector control generates powerful starting torque and allows precision control at low speeds.
- Interfaces to match gearless, **SPM synchronous motors and every type of absolute encoder**. High resolution and pole position detection for a smooth and safe ride.

Control Mode	Starting Torque	Speed Range	Motor Encoders and Option Cards
V/f Control	150% at 3 Hz*	1:40	N/A
Open Loop Vector Control	200% at 0.3 Hz*	1:200	N/A
Closed Loop Vector Control	200% at 0 r/min*1	1:1500	Incremental Encoders: - PG-X3 (Line Driver) - PG-B3 (Complementary)
Closed Loop Vector Control for PM	200% at 0 r/min*	1:1500	Incremental Encoders: - PG-X3 (Line Driver) - PG-B3 (Complementary) Absolute Encoders: - PG-F3 (EnDat, HiPERFACE) - PG-E3 (HEIDENHAIN ERN1387)

\* Drive and motor must be matched appropriately.

## Reduced Operation Time and More Powerful Braking

### Improved operation efficiency

- L1000 calculates the stopping distance to **minimize operation time**.  
"Direct Landing" function is also available.
- These features improve operation efficiency as well as greater stopping precision.
- **Short Floor** minimizes the "creep speed" time for faster, more efficient operation.

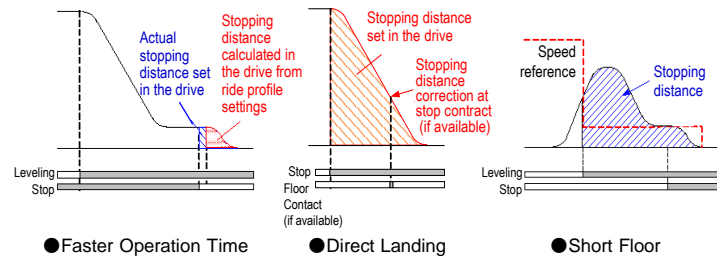

● Faster Operation Time

● Direct Landing

● Short Floor

## Loaded with Auto-Tuning Features

- L1000 is loaded with a variety of Auto-Tuning methods to ensure top performance.
- Rotational Auto-Tuning and Stationary Auto-Tuning are available for induction motors as well as synchronous motors.  
**Motor tuning features optimize drive settings without needing to disconnect the rope or car.**
- Tuning features for connected machinery.

### Types of Auto-Tuning

Motor Tuning	Load Tuning
<b>Rotational Auto-Tuning</b>	<b>Inertia Tuning</b>
<b>Stationary Auto-Tuning</b>	Optimizes deceleration time, Feed Forward, and functions (available soon)
<b>Motor Resistance Auto-Tuning</b>	
<b>Encoder Offset Auto-Tuning</b>	

- Brand new Auto-Tuning methods allow L1000 to continuously analyze changes in motor characteristics during run for highly precise speed control (when using Open Loop Vector Control)

# 2. Smooth, Comfortable Ride

## Smooth Operation

- L1000 has 1/2 the torque ripple compared to our earlier models, for an even smoother ride.
- Designed specifically for elevator applications, L1000 provides precise motor torque performance capability for smoother acceleration and deceleration.

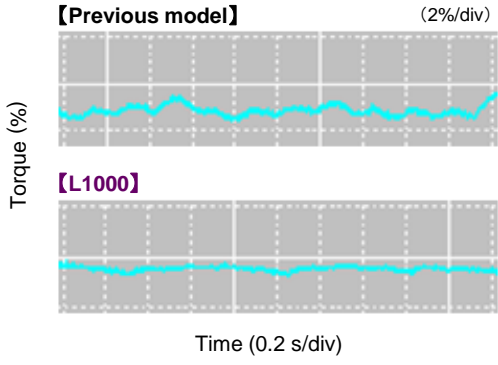

● Torque Ripple Comparison (Closed Loop Vector at zero speed)

## Overshoot and Anti-Vibration Control

- Feed Forward achieves ideal speed response, eliminating vibration and overshoot, and makes it easy to tweak the speed control loop (ASR). (Available soon)
- Adjust jerk settings at the start and end of acceleration and deceleration to create a perfectly smooth ride.

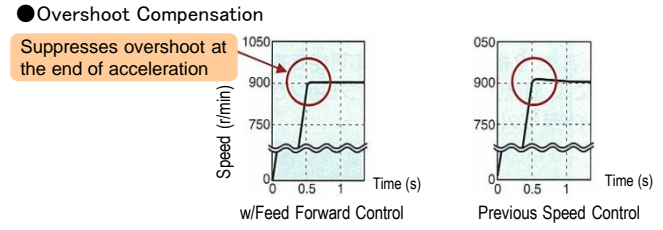
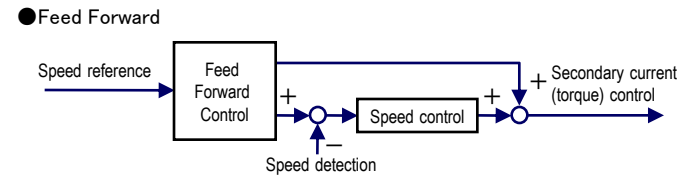

## High Performance Starting Torque without Sensors

- Even without a load sensor, high-performance torque compensation (Advanced Anti-Rollback\*) and high-resolution absolute encoder eliminate shock when the brake is released. Simplifying load sensor control signals makes cumbersome adjustments unnecessary.

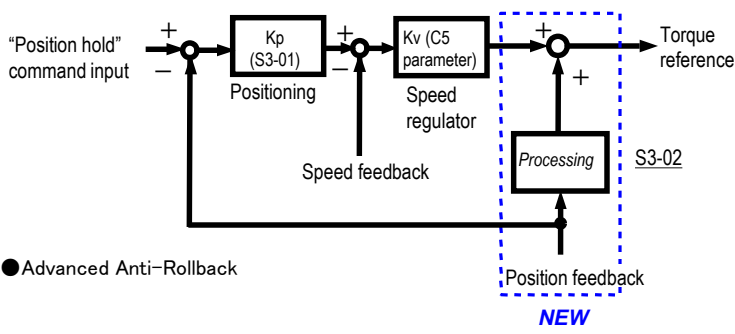

● Advanced Anti-Rollback

\* Advanced Anti-Rollback: Torque compensation function that eliminates shock at start up by preventing the car from moving when the brake is released.

- Anti-Rollback with sensors is easy to adjust, preventing shock start and stop.

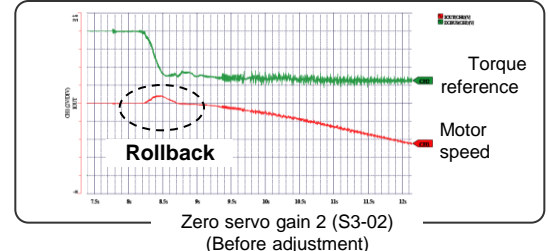

Zero servo gain 2 (S3-02) (Before adjustment)

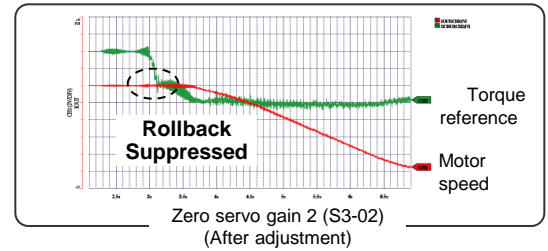

Zero servo gain 2 (S3-02) (After adjustment)

## Variety of Braking Functions

- All models up to 30 kW are equipped with a braking transistor for even more powerful braking options by just adding a braking resistor.

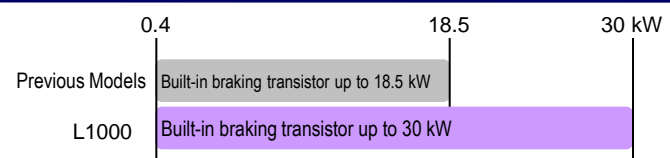

## L1000A LINE UP

Motor Capacity	kW	1.5	2.2	3.7	5.5	7.5	11	15	18.5	22	30	37	45	55	75	90	110
200 V Class	Model CIMR-LT2A	0008	0011	0018	0025	0033	0047	0060	0075	0085	0115	0145	0180	0215	0283	0346	0415
400 V Class	Model CIMR-LT4A	0005	0006	0009	0015	0018	0024	0031	0039	0045	0060	0075	0091	0112	0150	0180	0216

# 3. Safety

## Rescue Operation

Rescue Operation switches to backup battery or UPS in case of a power outage

- Both single-phase and 3-phase 220 V UPS and 48-96 Vdc battery (24 V control power supply) can keep the elevator running in case of an emergency. Possible with all 200 V and 40 V class models (400 V class requires a 400 V class UPS)
- L1000 automatically adjusts speed if a voltage drop occurs to prevent loss in motor speed.
- Light Load Direction Search function triggered by UPS and battery voltage is provided.

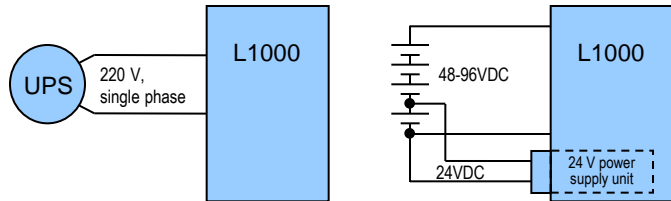

● UPS Wiring and Operation

● Backup Battery Wiring and Operation

\* The illustrations above have been simplified, omitting switches and control signals that are otherwise required. Refer to the wiring diagrams included with the components in question.

## Safe Disable Function

Protect the elevator application with immediate fault detection.

- L1000 protects the entire elevator application by detecting overacceleration, speed reversal, wiring errors, and improper parameter settings.
- Hardware sensors respond immediately if the motor encoder signal is lost, ensuring an even higher level of safety.

● Overacceleration Fault Detection

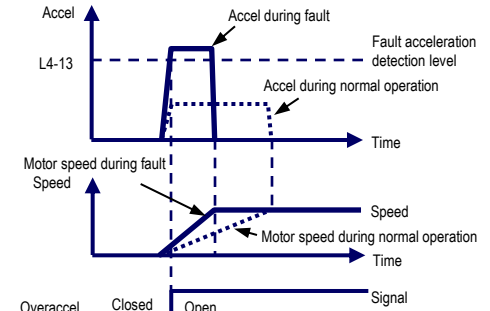

\* Actual operation varies by the control mode and motor encoder.

## Safe Disable Function

### Safety regulations

- Fully compliant with EN954-1 Cat. 3, ISO13849-1 (Cat. 3, PLd), and IEC/EN61058 SIL2, while eliminating the need for extra peripherals. Helps to easily satisfy EU standard for elevators EN81-1.

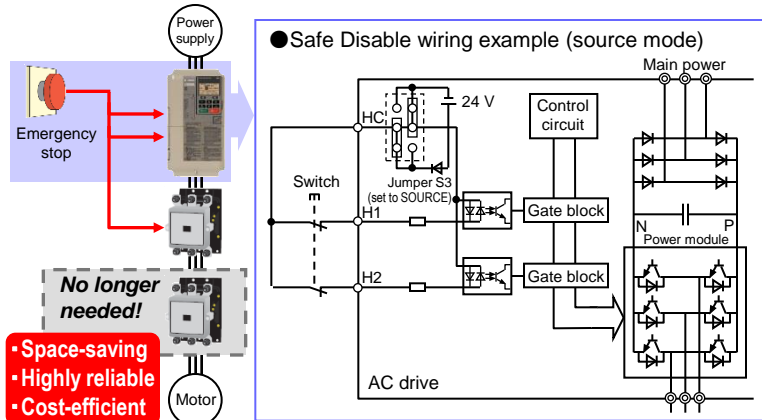

- Space-saving
- Highly reliable
- Cost-efficient

### Monitor status of input power supply

- Customized hardware immediately detects phase loss from the input power supply. Detection remains active regardless of whether the drive is running or stopped. An output signal can also be setup if a phase loss occurs.



## Preventative Warnings

### Performance Life Monitors

- L1000 is equipped with performance life monitors that notify the user of part wear and maintenance periods to prevent problems before they occur.

● Alarm Signals Output PLC or Control Device

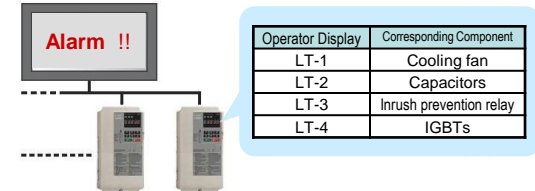

## Long-Life Performance

### Ten Years of Durable Performance

- Cooling fan, capacitors, relays, and IGBTs have been carefully selected and designed for a life expectancy up to ten years\*.

\* Assumes the drive is running continuously for 24 hours a day, 60 s/cycle, at 80% load, and an ambient temperature of 40°C.



# 4. Environmental

## High Efficiency: Energy Saving

- Superior efficiency and control with an IPM motor and Yaskawa's Energy Saving function  
Achieve even greater efficiency with a IPM motor and L1000's optimized control functions.
- Re-use regenerative power by adding a regenerative unit (VARISPEED-656RC5)  
Combining L1000 with VARISPEED-656RC5 to send regenerative power back to the power supply.
- L1000 is incredibly efficient— approximately 97%.  
Save even more energy by using the cooling fan ON/OFF control function when the cooling fan is not needed.

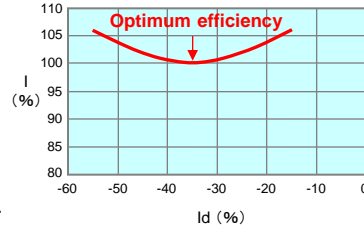

● Maximizing Control Efficiency with an IPM Motor (minimizing output current (I) during operation)

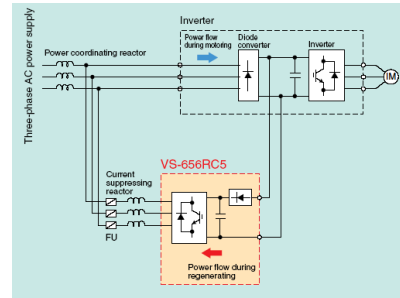

● Regenerative Power Supply with RC5 (re-using regenerative energy)

## High Performance: Low Harmonic Distortion

- Built-in DC reactor suppresses harmonic distortion to keep the input power factor above 90%.  
\* Models 18.5 kW and below offer a built-in DC reactor as an option.



- Yaskawa also offers 12-pulse and 18-pulse rectifier options\*, as well as filters to minimize harmonic distortion.  
\* Available soon. Requires a separate 3-winding or 4-winding transformer.

● Input Current Waveform  
No reactor

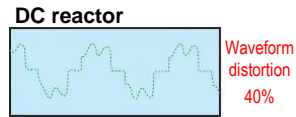

## RoHS

- All standard products are fully compliant with the EU's RoHS directive.



# 5. Easy Setup and Maintenance

## Terminal Block with Parameter Backup

The Drive Industry's First Terminal Board with a Parameter Backup Function

- The terminal block's ability to save parameter setting data makes it a breeze to get the application back online in the event of a failure requiring drive replacement.

● L1000A Terminal Block



Parameter		
Name	Number	Setting
Control Mode Selection	A1-02	0
Frequency Reference Selection 1	b1-01	1
Run Command Selection 1	b1-02	1

## DriveWizard Plus

### Engineering Tool DriveWizard Plus

- Manage the unique settings for all your drives with a personal computer (PC).
- An indispensable tool for drive setup and maintenance. Edit parameters, access all monitors, create customized operation sequences, and observe drive performance with the oscilloscope function.
- The Drive Replacement feature in DriveWizard Plus saves valuable time during equipment replacement and application upgrades by automatically programming parameters for full compatibility.
- Equipped with a USB port for easy connection to a personal computer.

● Connecting L1000 and a PC with USB



Note: Users can also use the WV103 cable included with earlier Yaskawa models. Simply remove the operator keypad to access the comm. port.

## Easy Setup

### Quick setup and easy maintenance

- Set speed, acceleration, and jerk parameters in **elevator units**.
- All models come standard with an LED unit equipped with a Copy function that lets the user quickly upload and download parameter settings.
- LCD operator keypad option available
- USB Copy Unit is available to copy parameter settings and program multiple drives instantly.
- The **Setup Mode** gives the user access to just those parameters needed to get the drive up and running right away.
- The **Verify Function** lets the user check parameters that may have been changed from their default values.



● LED Operator (standard)



● LCD Operator (optional)



● USB Copy Unit (optional)

● Verify Function

List of parameters that have been changed from their default settings.

Parameter Name	No.	Default	Set value
Speed reference selection	b1-01	1	0
Acceleration time	C1-01	3.00s	3.50s
Deceleration time	C1-02	3.00s	3.50s
⋮	⋮	⋮	⋮

# Standard Specifications

## 200 V Class

Item		Specifications																
Model CIMR-LT2A		0008	0011	0018	0025	0033	0047	0060	0075	0085	0115	0145	0180	0215	0283	0346	0415	
Max. Applicable Motor Capacity <sup>1</sup>		kW	1.5	2.2	3.7	5.5	7.5	11	15	18.5	22	30	37	45	55	75	90	110
Input	Rated Input Current <sup>2</sup>	A	7.5	11	18.9	28	37	52	68	80	82	111	136	164	200	271	324	394
Output	Rated Output Capacity <sup>3</sup>	kVA	3 <sup>4</sup>	4.2 <sup>4</sup>	6.7 <sup>4</sup>	9.5 <sup>4</sup>	12.6 <sup>4</sup>	17.9 <sup>4</sup>	23 <sup>4</sup>	29 <sup>4</sup>	32 <sup>4</sup>	44 <sup>4</sup>	55 <sup>5</sup>	69 <sup>5</sup>	82 <sup>5</sup>	108 <sup>5</sup>	132 <sup>5</sup>	158 <sup>5</sup>
	Rated Output Current	A	8 <sup>4</sup>	11 <sup>4</sup>	17.5 <sup>4</sup>	25 <sup>4</sup>	33 <sup>4</sup>	47 <sup>4</sup>	60 <sup>4</sup>	75 <sup>4</sup>	85 <sup>4</sup>	115 <sup>4</sup>	145 <sup>5</sup>	180 <sup>5</sup>	215 <sup>5</sup>	283 <sup>5</sup>	346 <sup>5</sup>	415 <sup>5</sup>
	Overload Tolerance	150% of rated output current for 60 s <sup>6</sup>																
	Carrier Frequency	User adjustable from 2 to 15 kHz										User adjustable from 2 to 10 kHz						
	Max. Output Voltage	Three-phase 200 to 240 V (proportional to input voltage)																
	Max. Output Frequency	200 Hz (user adjustable)																
Power	Rated Voltage/Rated Frequency	Three-phase 200 to 240 Vac 50/60 Hz										270 to 340 Vdc						
	Allowable Voltage Fluctuation	-15 to 10%																
	Allowable Frequency Fluctuation	±5%																
	Power Supply	kVA	4.1	5.8	9.5	14	18	27	36	44	37	51	62	75	91	124	148	180
Harmonics Suppression	DC Reactor	Option								Built-in								
Braking Function	Braking Transistor	Built-in										Option						

- \* 1: The motor capacity (kW) refers to a Yaskawa 4-pole induction motor (200 V, 60 Hz). The rated output current of the drive output amps should be equal to or greater than the motor rated current.
- \* 2: Value displayed is for when operating at the rated output current. This value may fluctuate based on the power supply side impedance, as well as the input current, power supply transformer, input side reactor, and wiring conditions.
- \* 3: Rated output capacity is calculated with a rated output voltage of 220 V.
- \* 4: Carrier frequency is set to 8 kHz. Current derating is required in order to raise the carrier frequency.
- \* 5: Carrier frequency is set to 5 kHz. Current derating is required in order to raise the carrier frequency.
- \* 6: Peak current should be kept under 150%. Be sure to check current levels during a test run, and make adjustments accordingly. Repeatedly exceeding 150% of the rated current causes thermal wear on the drive's IGBTs, and will shorten their expected performance life. The drive is rated to start and stop three million times, assuming the carrier frequency is left at its default setting with a peak current of 150%.

## 400 V Class

Item		Specifications																
Model CIMR-LT4A		0005	0006	0009	0015	0018	0024	0031	0039	0045	0060	0075	0091	0112	0150	0180	0216	
Max. Applicable Motor Capacity <sup>1</sup>		kW	1.5	2.2	3.7	5.5	7.5	11	15	18.5	22	30	37	45	55	75	90	110
Input	Rated Input Current <sup>2</sup>	A	4.4	6	10.4	15	20	29	39	44	43	58	71	86	105	142	170	207
Output	Rated Output Capacity <sup>3</sup>	kVA	3.7 <sup>4</sup>	4.2 <sup>4</sup>	7 <sup>4</sup>	11.3 <sup>4</sup>	13.7 <sup>4</sup>	18.3 <sup>4</sup>	24 <sup>4</sup>	30 <sup>4</sup>	34 <sup>4</sup>	48 <sup>4</sup>	57 <sup>4</sup>	69 <sup>4</sup>	85 <sup>5</sup>	114 <sup>5</sup>	137 <sup>5</sup>	165 <sup>5</sup>
	Rated Output Current	A	4.8 <sup>4</sup>	5.5 <sup>4</sup>	9.2 <sup>4</sup>	14.8 <sup>4</sup>	18 <sup>4</sup>	24 <sup>4</sup>	31 <sup>4</sup>	39 <sup>4</sup>	45 <sup>4</sup>	60 <sup>4</sup>	75 <sup>4</sup>	91 <sup>4</sup>	112 <sup>5</sup>	150 <sup>5</sup>	180 <sup>5</sup>	216 <sup>5</sup>
	Overload Tolerance	150% of rated output current for 60 s <sup>6</sup>																
	Carrier Frequency	User adjustable from 2 to 15 kHz										User adjustable from 2 to 10 kHz						
	Max. Output Voltage	Three-phase 380 to 480 V (proportional to input voltage)																
	Max. Output Frequency	200 Hz (user adjustable)																
Power	Rated Voltage/Rated Frequency	Three-phase 380 to 480 Vac 50/60 Hz										510 to 680 Vdc						
	Allowable Voltage Fluctuation	-15 to 10%																
	Allowable Frequency Fluctuation	±5%																
	Power Supply	kVA	4.3	6.1	10.0	14.6	19.2	28.4	37.5	46.6	39.3	53.0	64.9	78.6	96.0	129.9	155	189
Harmonics Suppression	DC Reactor	Option								Built-in								
Braking Function	Braking Transistor	Built-in										Option						

- \* 1: The motor capacity (kW) refers to a Yaskawa 4-pole induction motor (400 V, 60 Hz). The rated output current of the drive output amps should be equal to or greater than the motor rated current.
- \* 2: Value displayed is for when operating at the rated output current. This value may fluctuate based on the power supply side impedance, as well as the input current, power supply transformer, input side reactor, and wiring conditions.
- \* 3: Rated output capacity is calculated with a rated output voltage of 440 V.
- \* 4: Carrier frequency is set to 8 kHz. Current derating is required in order to raise the carrier frequency.
- \* 5: Carrier frequency is set to 5 kHz. Current derating is required in order to raise the carrier frequency.
- \* 6: Peak current should be kept under 150%. Be sure to check current levels during a test run, and make adjustments accordingly. Repeatedly exceeding 150% of the rated current causes thermal wear on the drive's IGBTs, and will shorten their expected performance life. The drive is rated to start and stop three million times, assuming the carrier frequency is left at its default setting with a peak current of 150%.



# Dimensions

## Enclosure Panel (NEMA Type 1)

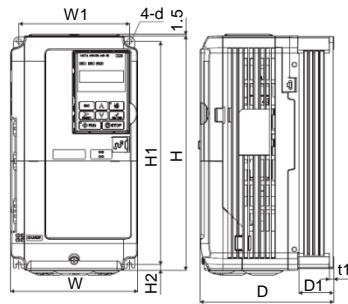

Figure 1

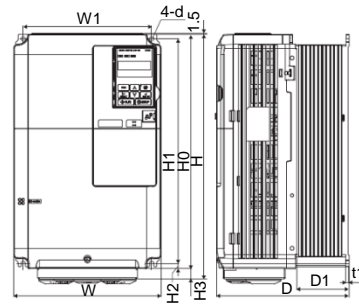

Figure 2

	Applicable Motor (kW)	Model CIMR-LT2A	Figure	Dimensions (mm)										Weight (kg)	
				W	H	D	W1	H1	H0	H2	H3	D1	t1		d
200 V Class	1.5	0008	1	140	260	147	122	248	—	6	—	38	5	M5	3.2
	2.2	0011		140	260	147	122	248	—	6	—	38	5	M5	3.2
	3.7	0018		140	260	164	122	248	—	6	—	55	5	M5	3.5
	5.5	0025		140	260	167	122	248	—	6	—	55	5	M5	4.0
	7.5	0033		140	260	167	122	248	—	6	—	55	5	M5	4.0
	11	0047		180	300	187	160	284	—	8	—	75	5	M5	5.6
	15	0060		220	350	197	192	335	—	8	—	78	5	M6	8.7
	18.5	0075	2	220	365	197	192	335	350	8	15	78	5	M6	9.7
	Applicable Motor (kW)	Model CIMR-LT4A	Figure	Dimensions (mm)										Weight (kg)	
				W	H	D	W1	H1	H0	H2	H3	D1	t1		d
400 V Class	1.5	0005	1	140	260	147	122	248	—	6	—	38	5	M5	3.2
	2.2	0006		140	260	164	122	248	—	6	—	55	5	M5	3.4
	3.7	0009		140	260	164	122	248	—	6	—	55	5	M5	3.5
	5.5	0015		140	260	167	122	248	—	6	—	55	5	M5	3.9
	7.5	0018		140	260	167	122	248	—	6	—	55	5	M5	3.9
	11	0024		180	300	167	160	284	—	8	—	55	5	M5	5.4
	15	0031		180	300	187	160	284	—	8	—	75	5	M5	5.7
	18.5	0039	2	220	350	197	192	335	—	8	—	78	5	M6	8.3

## Open-Chassis (IP00)

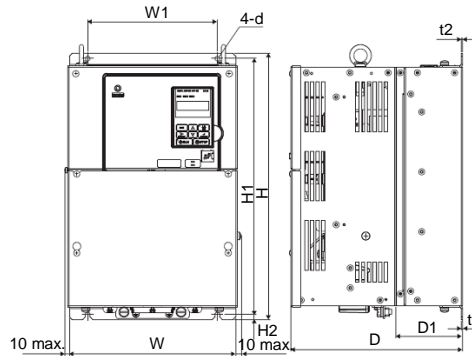

Figure 1

	Applicable Motor (kW)	Model CIMR-LT2A	Figure	Dimensions (mm)										Weight (kg)
				W	H	D	W1	H1	H2	D1	t1	t2	d	
200 V Class	22	0085	1	250	400	258	195	385	7.5	100	2.3	2.3	M6	21
	30	0115		275	450	258	220	435	7.5	100	2.3	2.3	M6	25
	37	0145		325	550	283	260	535	7.5	110	2.3	2.3	M6	37
	45	0180		325	550	283	260	535	7.5	110	2.3	2.3	M6	38
	55	0215		450	705	330	325	680	12.5	130	3.2	3.2	M10	76
	75	0283		450	705	330	325	680	12.5	130	3.2	3.2	M10	80
	90	0346		500	800	350	370	773	13	130	4.5	4.5	M12	98
	110	0415		500	800	350	370	773	13	130	4.5	4.5	M12	99
	Applicable Motor (kW)	Model CIMR-LT4A	Figure	Dimensions (mm)										Weight (kg)
				W	H	D	W1	H1	H2	D1	t1	t2	d	
400 V Class	22	0045	1	250	400	258	195	385	7.5	100	2.3	2.3	M6	21
	30	0060		275	450	258	220	435	7.5	100	2.3	2.3	M6	25
	37	0075		325	510	258	260	495	7.5	105	2.3	3.2	M6	36
	45	0091		325	510	258	260	495	7.5	105	2.3	3.2	M6	36
	55	0112		325	550	283	260	535	7.5	110	2.3	2.3	M6	41
	75	0150		325	550	283	260	535	7.5	110	2.3	2.3	M6	42
	90	0180		450	705	330	325	680	12.5	130	3.2	3.2	M10	79
	110	0216		500	800	350	370	773	13	130	4.5	4.5	M12	96



# Watt Loss and Drive Derating

## Watt Loss Data

	Applicable Motor (kW)	Model CIMR-LT2A[ ]	Carrier Frequency 8 kHz			
			Rated Amps (A)	Heatsink Loss (W)	Interior Unit Loss (W)	Total Loss (W)
200 V Class	1.5	0008	8	43	52	95
	2.2	0011	11	64	58	122
	3.7	0018	17.5	101	67	168
	5.5	0025	25	194	92	287
	7.5	0033	33	214	105	319
	11	0047	47	280	130	410
	15	0060	60	395	163	558
	18.5	0075	75	460	221	681
	22	0085	85	510	211	721
	30	0115	115	662	250	912
	37	0145	145 *	816 *	306 *	1122 *
	45	0180	180 *	976 *	378 *	1354 *
	55	0215	215 *	1514 *	466 *	1980 *
	75	0283	283 *	1936 *	588 *	2524 *
90	0346	346 *	2564 *	783 *	3347 *	
110	0415	415 *	2672 *	954 *	3626 *	
400 V Class	Applicable Motor (kW)	Model CIMR-LT4A[ ]	Carrier Frequency 8 kHz			
			Rated Amps (A)	Heatsink Loss (W)	Interior Unit Loss (W)	Total Loss (W)
	1.5	0005	4.8	37	49	87
	2.2	0006	5.5	48	53	101
	3.7	0009	9.2	69	61	130
	5.5	0015	14.8	135	86	221
	7.5	0018	18	150	97	247
	11	0024	24	208	115	323
	15	0031	31	263	141	403
	18.5	0039	39	330	179	509
	22	0045	45	349	170	518
	30	0060	60	484	217	701
	37	0075	75	563	254	817
	45	0091	91	723	299	1022
55	0112	112 *	908 *	416 *	1325 *	
75	0150	150 *	1340 *	580 *	1920 *	
90	0180	180 *	1771 *	541 *	2313 *	
110	0216	216 *	2360 *	715 *	3075 *	

\* 1: These values assume the carrier frequency is set to 5 kHz.

## Derating

The drive can be operated at above the rated temperature, altitude, and default carrier frequency by derating the drive capacity. A drive with a rated output current of 10 A can be derated to having an output current of 8 A, thus allowing the drive to operate continuously at a higher temperature.

### Derating as the carrier frequency

As the carrier frequency of the drive is increased above the default setting, the drive's rated output current must be derated according to Figure 1 to Figure 4.

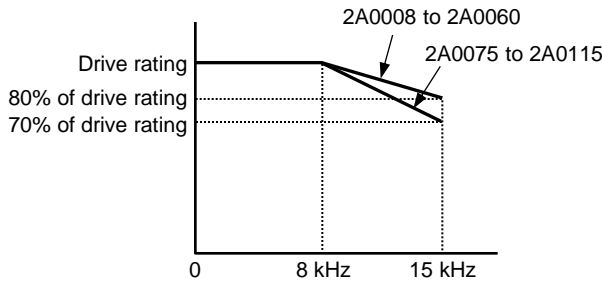

Figure 1. CIMR-LT2A0018 to 2A0115

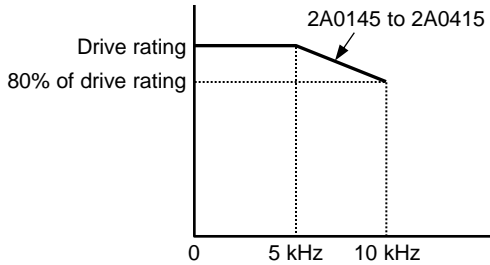

Figure 2. CIMR-LT2A0145 to 2A0415

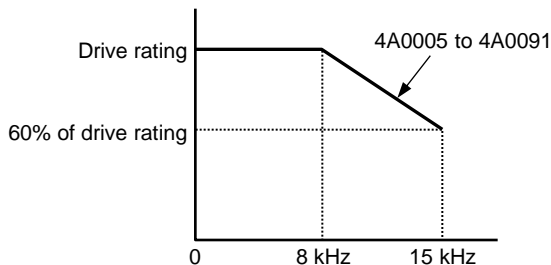

Figure 3. CIMR-LT4A0009 to 4A0091

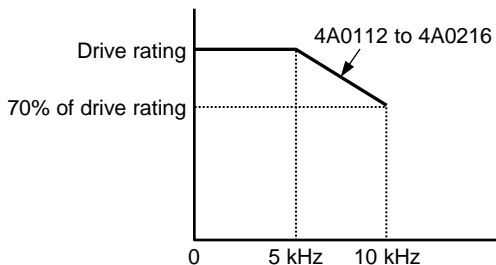
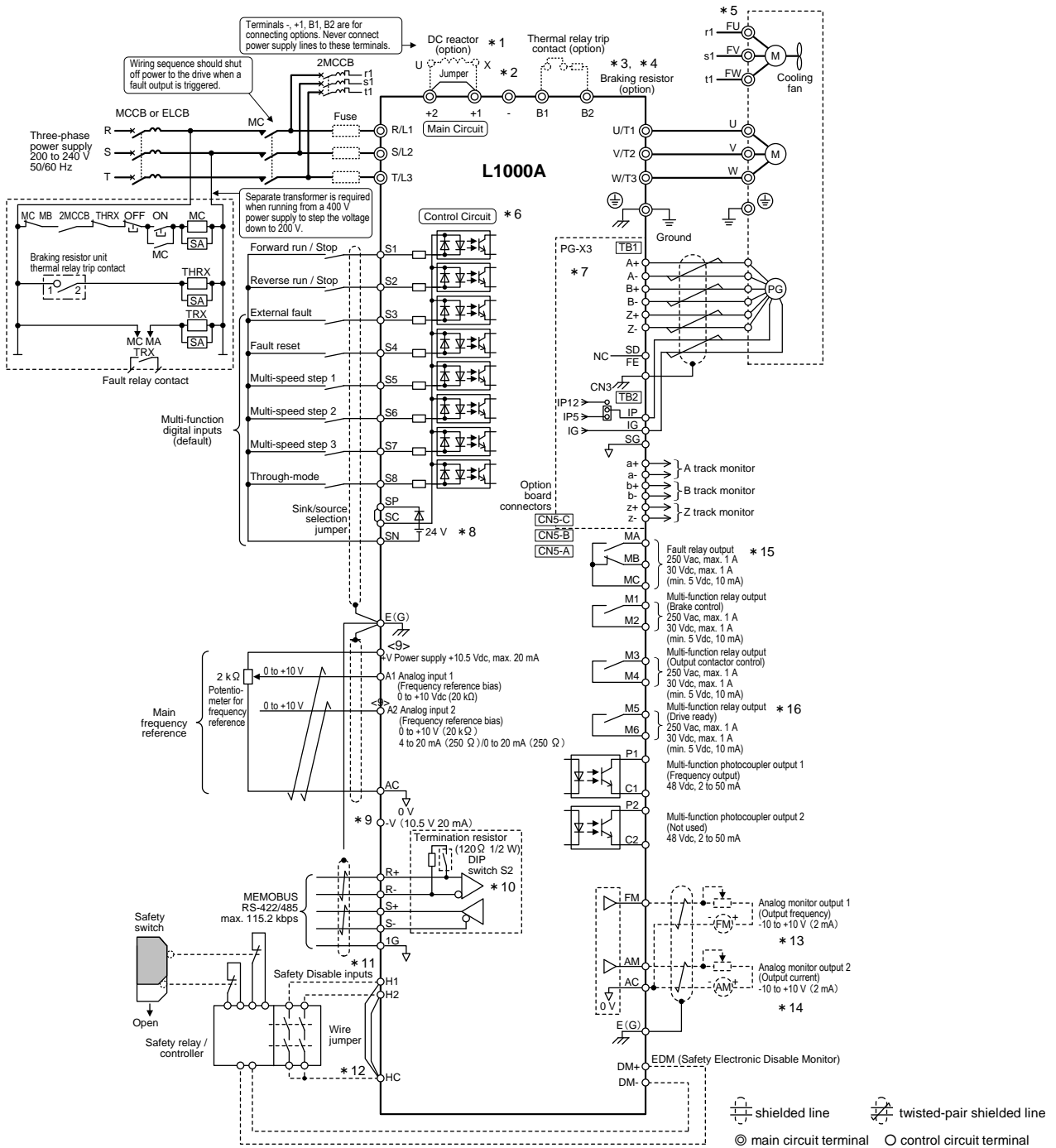

Figure 4. CIMR-LT4A0112 to 4A0216

# Standard Connection Diagram

## CIMR-LT2A0033: 200 V Class 7.5 kW



- \*1: Remove the jumper between terminals +1 and +2 when installing a DC reactor option.
- \*2: Models CIMR-LT2A0085 to 2A0415 and 4A0045 to 4A0216 come with a built-in DC reactor.
- \*3: Disable protection for built-in braking transistor (L8-55 = 1) when using a regenerative converter, regenerative unit, or braking unit (and therefore not using the built-in braking transistor).
- \*4: Drives using a braking resistor unit should wire a thermal relay so that the power supply is also shut off if overheat occurs.
- \*5: Self-cooling motors do not require wiring that would be necessary with motors using a cooling fan.
- \*6: A separate 24 V power supply is required to have the control circuit still operating while the power to the main circuit is shut off.
- \*7: For control modes that do not use a motor speed feedback signal, PG option card wiring is not necessary.
- \*8: Place jumpers to set the drive for sink or source (internal or external power supply). The default setting is for sink (internal power supply).
- \*9: The maximum output current capacity for the +V and -V terminals on the control circuit is 20 mA. Never short terminals +V, -V, and AC, as this can cause erroneous operation or damage the drive.
- \*10: Enable the termination resistor in the last drive in a MEMOBUS/Modbus network by setting DIP switch S2 to the ON position.
- \*11: The sink/source setting for the Safe Disable input is the same as with the sequence input. Jumper S3 has the drive set for an external power supply. When not using the Safe Disable input feature, remove the jumper shorting the input and connect an external power supply.
- \*12: Disconnect the wire jumper between HC - H1 and HC - H2 when utilizing the Safe Disable input.
- \*13: Monitor outputs work with devices such as analog frequency meters, ammeters, voltmeters, and wattmeters. Do not use these outputs in a feedback loop.
- \*14: Note that if the drive is set to trigger a fault output whenever the fault restart function is activated (L5-02 = 1), then a sequence to interrupt power when a fault occurs will result in shutting off the power to the drive as the drive attempts to restart itself. The default setting for L5-02 is 0 (fault output active during restart attempt).
- \*15: MA, MB, and MC must be used as fault outputs. They must be set up so that any interruption in the safety chain shuts off drive output.
- \*16: Even though no fault is present conditions where the drive can not start can occur, e.g., when the digital operator is left in the Programming Mode. Use the "Drive Ready" output (default set to terminals M5-M6) to interlock operation in such situations.

L1000 and Yaskawa PM Motors Flat-type and base-mount motors

	Weight (Kg)	Elevator Speed (m/min)	Motor			L1000
			Model SSE4- [ ]	Motor Output (kW)	Motor Speed (r/min)	CIMR-LT [ ]
200 V Class	450	45	22P1072	2.1	72	2A0025
		60	22P8096	2.8	96	2A0025
		90	24P2144	4.2	144	2A0033
	600	45	22P8072	2.8	72	2A0033
		60	23P7096	3.7	96	2A0033
		90	25P6144	5.6	144	2A0047
		105	26P5168	6.5	168	2A0047
	750	45	23P5072	3.5	72	2A0033
		60	24P6096	4.6	96	2A0033
		90	26P9144	6.9	144	2A0060
		105	28P1168	8.1	168	2A0060
	900	45	24P2072	4.2	72	2A0047
		60	25P6096	5.6	96	2A0047
		90	28P3144	8.3	144	2A0060
		105	29P7168	9.7	168	2A0060
	1000	45	24P6072	4.6	72	2A0047
60		26P2096	6.2	96	2A0047	
90		29P2144	9.2	144	2A0075	
105		2011168	11	168	2A0075	
400 V Class	450	45	42P1072	2.1	72	4A0015
		60	42P8096	2.8	96	4A0015
		90	44P2144	4.2	144	4A0018
		105	44P8168	4.8	168	4A0018
	600	45	42P8072	2.8	72	4A0018
		60	43P7096	3.7	96	4A0018
		90	45P6144	5.6	144	4A0024
		105	46P5168	6.5	168	4A0024
	690	45	43P2072	3.2	72	4A0018
		60	44P3096	4.3	96	4A0018
		90	46P9144	6.9	144	4A0031
		105	48P1168	8.1	168	4A0031
	750	45	43P2072	3.5	72	4A0018
		60	44P3096	4.6	96	4A0018
		90	46P9144	6.9	144	4A0031
		105	48P1168	8.1	168	4A0031
	900	45	44P2072	4.2	72	4A0018
		60	45P6096	5.6	96	4A0018
		90	48P3144	8.3	144	4A0031
		105	49P7168	9.7	168	4A0031
	1000	45	44P6072	4.6	72	4A0024
		60	46P2096	6.2	96	4A0024
		90	49P2144	9.2	144	4A0031
		105	4011168	11	168	4A0031
120		4013192	13	192	4A0039	

Model Number Key

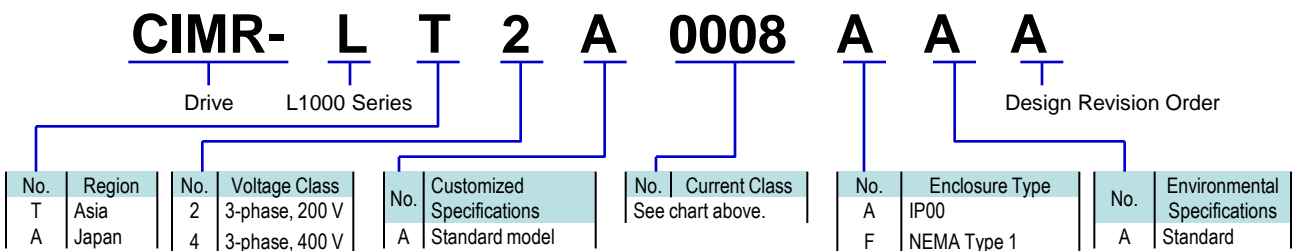

# Peripherals Devices and Options

Device	Model	Purpose		
<b>Interface Options</b>				
Operator Extension Cable	WV001/WV003	Cable for connecting the LED operator (1 m or 3 m cables available) RJ-45 8 pin UTP CAT5e cable (T568B)		
USB Copy Unit	JVOP-181	Copy parameter settings in a single step, then transfer those settings to another drive. Cable included. Contact a Yaskawa representative to obtain a USB driver.		
<b>Operator Mounting Bracket</b>				
Installation Support Set A	EZZ020642A	Mounts the digital operator to the outside of an enclosure panel. For use with holes through the panel.		
Installation Support Set B	EZZ020642B	Mounts the digital operator to the outside of an enclosure panel. For use with mounted threaded studs.		
<b>Other Options</b>				
24 V Power Supply	PS-A10LB PS-A10HB	Back power supply for the control circuit and option boards for when the main circuit loses power. Allows the user to refer to parameter settings and view drive monitors during a power loss.		
<b>Option Cards</b>				
PG Speed Controller Card	Complimentary Type PG	PG-B3	Pulse generators and encoders are combined with a feedback signal to detect motor speed. Allows the drive to control the output frequency to keep motor speed constant.	For complimentary and open collector types: 3 track (A, B, Z pulse) Single track compatible (A pulse) Maximum input frequency: 50 kHz Pulse monitor output: Open collector Voltage output for PG: 12 V, max. 200 mA
	Line Driver PG	PG-X3		For line drivers: 3 track (A, B, Z pulse) Single track compatible (A pulse) Maximum input frequency: 300 kHz Pulse monitor: Matches RS-422 Voltage output for PG: 5 or 12 V, max. 200 mA
	Encoder Type (EnDat)	PG-F3		For HEIDENHAIN EnDat2.1/01, EnDat2.2/01, EnDat2.2/22 : Maximum input frequency: 20 kHz Pulse monitor: Matches RS-422 Voltage output for encoder: 5 V, 330 mA max or 8 V, 150 mA max.  Encoder cable: 20 m max. * Pulse monitor cable: 30 m max. *Use a 17-pin encoder capable manufactured by HEIDENHAIN.
	Encoder Type (ERN1387)	PG-E3		For HEIDENHAIN ERN1387: Maximum input frequency: 20 kHz Pulse monitor: Matches RS-422 Voltage output for encoder: 5 V, 200 mA max. Encoder cable: 10 m max. * Pulse monitor cable: 30 m max. *Use a 17-pin encoder capable manufactured by HEIDENHAIN.
I/O Option Cards	Analog Monitor	AO-A3	Outputs analog signal for monitoring drive output state (output frequency, output current, etc.). Terminals: 2 analog outputs Output resolution: 11 bit signed (1/2048) Output voltage: -10 to +10 Vdc	
	Digital Input	DI-A3	Allows for a digital speed reference input. Terminals: 18 input terminals (including those for set and sign) Input signal: User-set binary 8/12/16 bit, BCD 2/3/4 Input power: 24 Vdc, 8 mA	
	Digital Output	DO-A3	Outputs isolated type digital signal for monitoring drive run state (alarm signal, zero speed detection, etc.) Terminals: 6 photocoupler outputs (48 V, 50 mA or less) 2 relay contact outputs (250 Vac, 1 A or less 30 Vdc, 1 A or less)	
Communications	CANopen	SI-S3	Connects the drive to a CANopen network.	

# Peripherals Devices

## Braking Unit



Stand-alone

Braking Unit  
[CDBR series]

Voltage	200 V Class			400 V Class		
Model: CDBR- <span style="border: 1px dashed black; padding: 0 5px;"> </span>	2022D	2037D	2110B	4030D	4045D	4220B
Max. Applicable Motor (kW)	22	37	110	30	45	220
Max. Discharge Current A/10%ED(10 s max.)	60	80	250	40	60	250
Rated Discharge Current A/continues	20	24	80	15	18	80
Min. Connectable Resistance (Ω)	6.4	5.0	1.6	19.2	12.8	3.2
Drive Watts Loss (Heat loss) (W)	27	38	64	24	36	71

Dimensions (mm)

Model: CDBR-2022D, -2037D, -4030D, 4045D

Model: CDBR-2110B

Model: CDBR-4220B

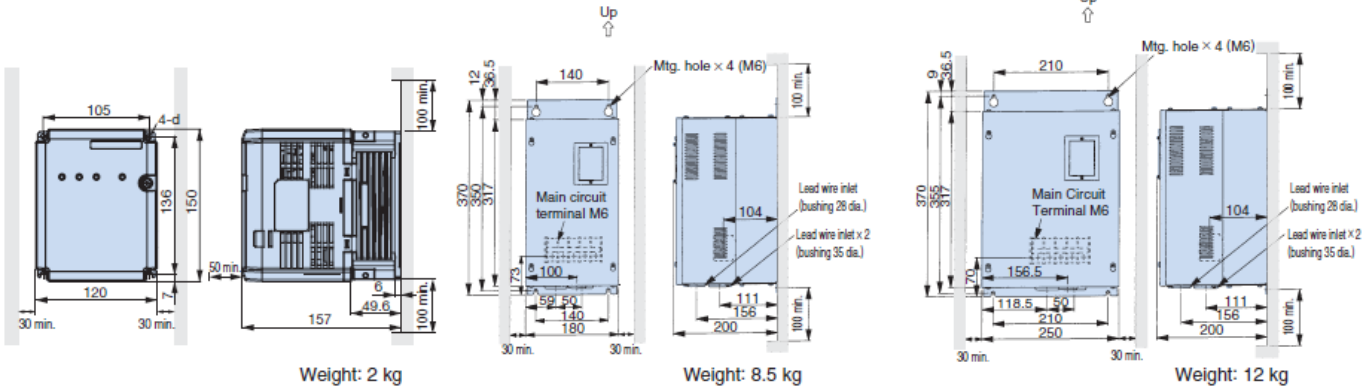

## POWER REGENERATIVE UNIT VARISPEED-656RC5



200 V Class

Rated Capacity (kW)	3.7	5.5	7.5	11	15	18.5	22	30	37
Model CIMR-R5A- <span style="border: 1px dashed black; padding: 0 5px;"> </span>	23P7	25P5	27P5	2011	2015	2018	2022	2030	2037

400 V Class

Rated Capacity (kW)	3.7	5.5	7.5	11	15	18.5	22	30	37	45	55	75
Model CIMR-R5A- <span style="border: 1px dashed black; padding: 0 5px;"> </span>	43P7	45P5	47P5	4011	4015	4018	4022	4030	4037	4045	4055	4075

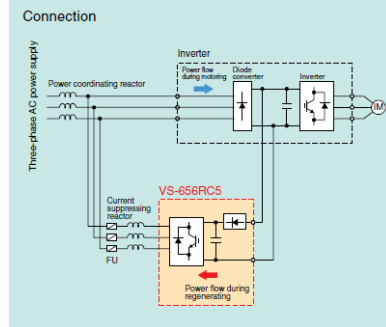

Refer to the catalog (No.KAE-S656-3) for details.

## 24 V Power Supply

The 24 V Power Supply Option maintains drive control circuit power in the event of a main power outage. The control circuit keeps the network communications and I/O data operational in the event of a power outage.

The installed option adds 50 mm to the total depth of the drive.



Weight: 0.2kg

Connection Diagram

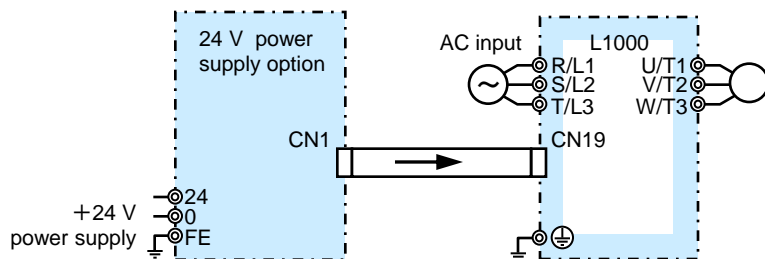

Model	Code No.
200 V Class: PS-A10LB	PS-A10LB
400 V Class: PS-A10HB	PS-A10HB

Note: Even if a back-up power supply is used for the control circuit, the main circuit must still have power in order to charge parameter settings.

# Peripherals Devices

## DC Reactor (UZDA-B for DC circuit)

Base device selection on motor capacity.

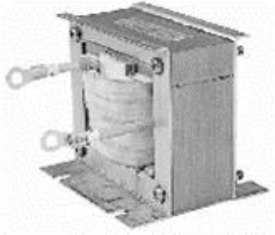

Lead Wire Type

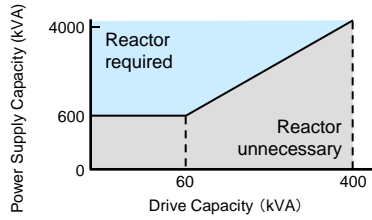

Note: Reactor recommended for power supplies larger than 600 kVA.

Connection Diagram

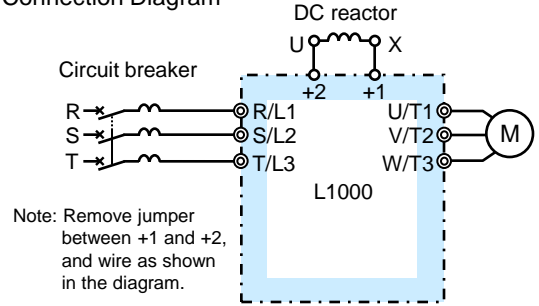

Note: Remove jumper between +1 and +2, and wire as shown in the diagram.

Dimensions (mm)

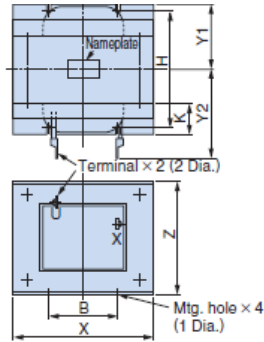

Figure 1

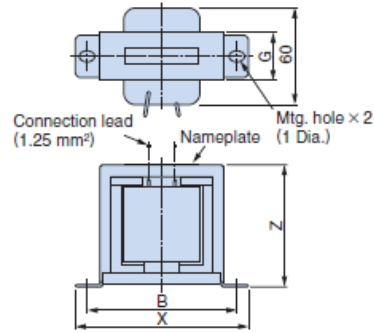

Figure 2

	Motor Capacity (kW)	Current (A)	Inductance (mH)	Code No.	Figure	Dimensions (mm)										Weight (kg)	Watt Loss (W)	Wire* Gauge (mm <sup>2</sup> )
						X	Y2	Y1	Z	B	H	K	G	φ1	φ2			
200 V Class	1.5	18	3	X010049	1	86	80	36	76	60	55	18	—	M4	M5	2	18	5.5
	2.2					105	90	46	93	64	80	26	—	M6	M6	3.2	22	8
	3.7					105	105	56	93	64	100	26	—	M6	M8	4.9	29	30
	5.5	36	1	X010050		133	120	52.5	117	86	80	25	—	M6	M8	6.5	45	30
	7.5					Built-in												
	11					Built-in												
	15	Built-in																
18.5	Built-in																	
22~110	Built-in																	

	Motor Capacity (kW)	Current (A)	Inductance (mH)	Code No.	Figure	Dimensions (mm)										Weight (kg)	Watt Loss (W)	Wire* Gauge (mm <sup>2</sup> )			
						X	Y2	Y1	Z	B	H	K	G	φ1	φ2						
400 V Class	1.5	5.7	11	X010053	2	90	—	—	60	80	—	—	32	M4	—	1	11	2			
	2.2					86	80	36	76	60	55	18	—	M4	M5	2	16	2			
	3.7	12	6.3	X010054		105	90	46	93	64	80	26	—	M6	M5	3.2	27	5.5			
	5.5					23	3.6	X010055	105	95	51	93	64	90	26	—	M6	M6	4	26	8
	7.5								115	125	57.5	100	72	90	25	—	M6	M6	6	42	14
	11	33	1.9	X010056		Built-in															
	15					Built-in															
18.5	Built-in																				
22~110	Built-in																				

\* Cable: Indoor PVC(75°C), ambient temperature 45°C, 3 lines max.



Terminal Type  
Dimensions (mm)

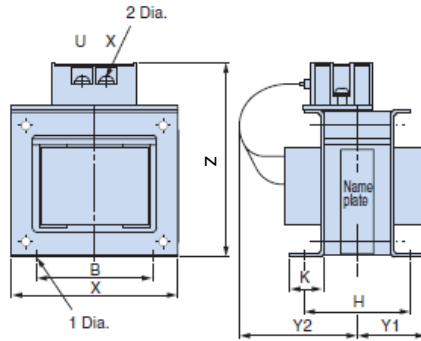

Figure 1

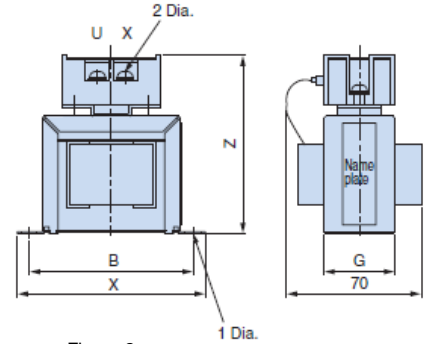
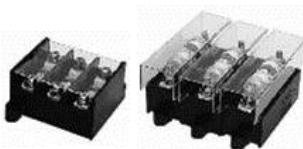

Figure 2

	Motor Capacity (kW)	Current (A)	Inductance (mH)	Code No.	Figure	Dimensions (mm)										Weight (kg)	Watt Loss (W)	
						X	Y2	Y1	Z	B	H	K	G	φ1	φ2			
200 V Class	1.5	18	3	300-027-131	1	86	84	36	101	60	55	18	—	M4	M4	2	18	
	2.2					105	94	46	129	64	80	26	—	M6	M4	3.2	22	
	3.7					105	124	56	135	64	100	26	—	M6	M6	4.9	29	
	5.5	36	1	300-027-132		133	147.5	52.5	160	86	80	25	—	M6	M6	6.5	44	
	7.5																	
	11																	
	15																	
18.5	90	0.4	300-027-139															
400 V Class	1.5	5.7	11	300-027-135	2	90	—	—	88	80	—	—	32	M4	M4	1	11	
	2.2					86	84	36	101	60	55	18	—	M4	M4	2	16	
	3.7	12	6.3	300-027-136		105	104	46	118	64	80	26	—	M6	M4	3.2	27	
	5.5					105	109	51	129	64	90	26	—	M6	M4	4	26	
	7.5																	115
	11	33	1.9	300-027-138														
	15																	
18.5	47	1.3	300-027-140															

## Fuse and Fuse Holder

Install a fuse to the drive input terminals to prevent damage in case a fault occurs.  
Refer to the instruction manual for information on UL-approved components.



【Fuji Electric FA Components & System Co., Ltd】

	Model CIMR-LT2A□	Fuse		Fuse Holder			Model CIMR-LT4A□	Fuse		Fuse Holder	
		Model	Qty.	Model	Qty.			Model	Qty.	Model	Qty.
200 V Class	0008	CR2LS-50	3	CM-1A	1	400 V Class	0005	CR6L-50	3	CMS-4	1
	0011										
	0018										
	0025						CR2L-125	CM-2A	1	0009	
	0033										
	0047										
	0060										
	0075										
	0085	CR2L-300	*				0015	CR6L-75	3	CMS-5	1
	0115										
	0145										
	0180										
	0215						CR2L-450	*			0024
	0283										
	0346										
0415											
0415	CR2L-600	*			0031	CR6L-100					3
0039											
0045											
0060					CR2L-800	*			0075		
0091											
0112											
0150											
0180											
0216	CS5F-800	*			0099	CR6L-150	3	*			
0112											
0150											
0180											
0216											

\* Manufacture does not recommended a specific fuse holder for this fuse.  
Contact the manufacture for information on fuse dimensions.

# L1000A

---

**DRIVE CENTER (INVERTER PLANT)**

2-13-1, Nishimiyaichi, Yukuhashi, Fukuoka, 824-8511, Japan  
Phone: 81-930-25-3844 Fax: 81-930-25-4369  
<http://www.yaskawa.co.jp>

**YASKAWA ELECTRIC CORPORATION**

New Pier Takeshiba South Tower, 1-16-1, Kaigan, Minatoku, Tokyo, 105-6891, Japan  
Phone: 81-3-5402-4502 Fax: 81-3-5402-4580  
<http://www.yaskawa.co.jp>

**YASKAWA AMERICA, INC.**

2121 Norman Drive South, Waukegan, IL 60085, U.S.A.  
Phone: (800) YASKAWA (927-5292) or 1-847-887-7000 Fax: 1-847-887-7310  
<http://www.yaskawa.com>

**YASKAWA ELETRICO DO BRASIL LTDA.**

Avenda Fagundes Filho, 620 Bairro Saude, Sao Paulo, SP04304-000, Brazil  
Phone: 55-11-3585-1100 Fax: 55-11-5581-8795  
<http://www.yaskawa.com.br>

**YASKAWA EUROPE GmbH**

Hauptstrasse 185, 65760 Eschborn, Germany  
Phone: 49-6196-569-300 Fax: 49-6196-569-398  
<http://www.yaskawa.eu.com>

**YASKAWA ELECTRIC UK LTD.**

1 Hunt Hill Orchardton Woods, Cumbernauld, G68 9LF, United Kingdom  
Phone: 44-1236-735000 Fax: 44-1236-458182  
<http://www.yaskawa.co.uk>

**YASKAWA ELECTRIC KOREA CORPORATION**

9F, Kyobo Securities Bldg., 26-4, Yeouido-dong, Yeongdeungpo-gu, Seoul, 150-737, Korea  
Phone: 82-2-784-7844 Fax: 82-2-784-8495  
<http://www.yaskawa.co.kr>

**YASKAWA ELECTRIC (SINGAPORE) PTE. LTD.**

151 Lorong Chuan, #04-01, New Tech Park, 556741, Singapore  
Phone: 65-6282-3003 Fax: 65-6289-3003  
<http://www.yaskawa.com.sg>

**YASKAWA ELECTRIC (CHINA) CO., LTD.**

12F, Carlton Bld., No.21 HuangHe Road, HuangPu District, Shanghai 200003, China  
Phone: 86-21-5385-2200 Fax: 86-21-5385-3299  
<http://www.yaskawa.com.cn>

**YASKAWA ELECTRIC (CHINA) CO., LTD. BEIJING OFFICE**

Room 1011, Tower W3 Oriental Plaza, No. 1 East Chang An Ave.,  
Dong Cheng District, Beijing, 100738, China  
Phone: 86-10-8518-4086 Fax: 86-10-8518-4082

**YASKAWA ELECTRIC TAIWAN CORPORATION**

9F, 16, Nanking E. Rd., Sec. 3, Taipei, 104, Taiwan  
Phone: 886-2-2502-5003 Fax: 886-2-2505-1280

**YASKAWA ELECTRIC INDIA PRIVATE LIMITED**

#17/A Electronics City, Hosur Road Bangalore 560 100 (Karnataka), India  
Phone: 91-80-4244-1900 Fax: 91-80-4244-1901  
<http://www.yaskawaindia.in>



YASKAWA ELECTRIC CORPORATION

In the event that the end user of this product is to be the military and said product is to be employed in any weapons systems or the manufacture thereof, the export will fall under the relevant regulations as stipulated in the Foreign Exchange and Foreign Trade Regulations. Therefore, be sure to follow all procedures and submit all relevant documentation according to any and all rules, regulations and laws that may apply. Specifications are subject to change without notice for ongoing product modifications and improvements.

© 2009 YASKAWA ELECTRIC CORPORATION. All rights reserved.

LITERATURE No.EZZ021066

Published in Japan August 2012