

# YASKAWA

## YASKAWA AC Drive GA700

High Performance Type

200 V CLASS, 0.4 to 110 kW  
400 V CLASS, 0.4 to 630 kW

### Best Value for Your Applications

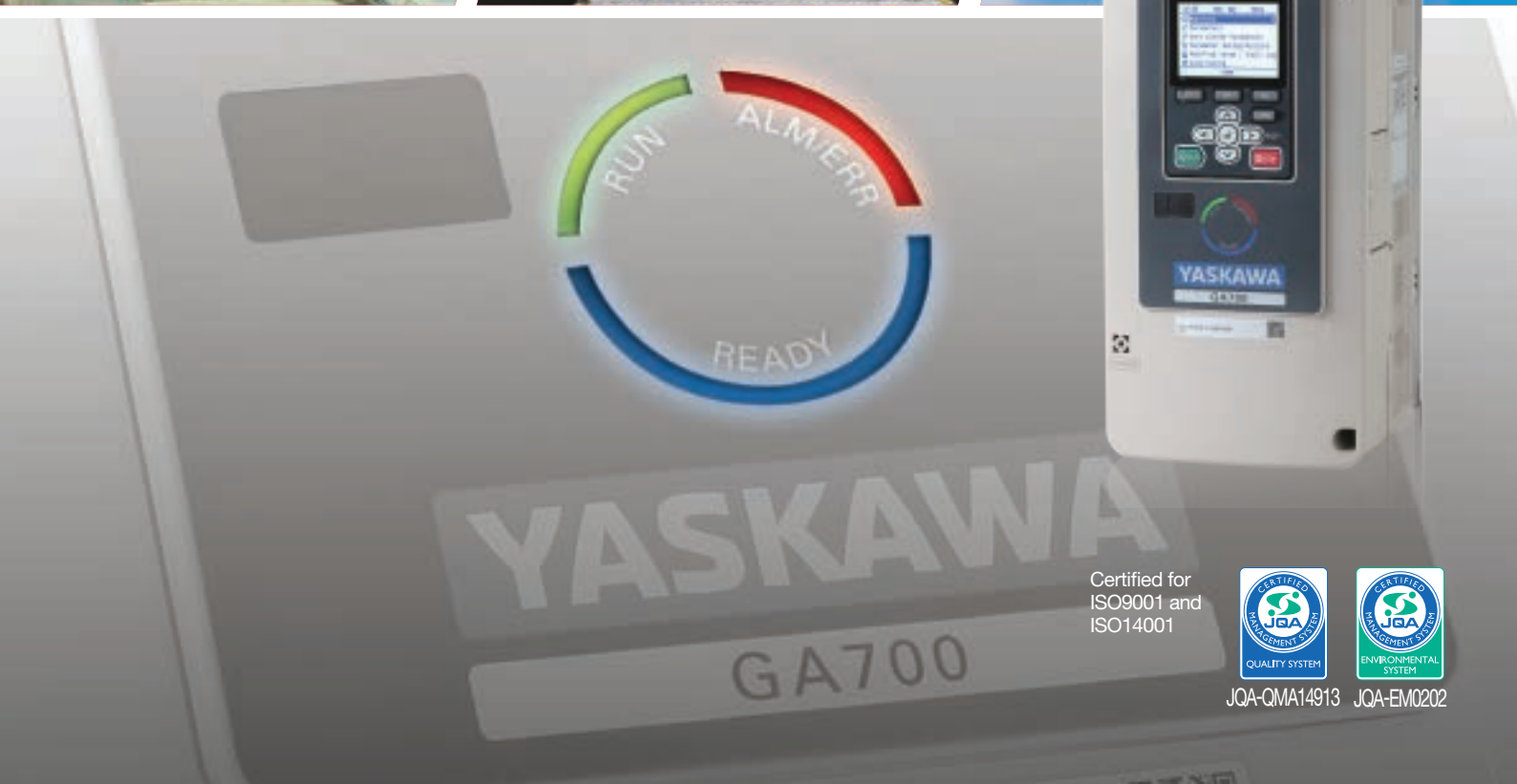

Certified for  
ISO9001 and  
ISO14001



JQA-QMA14913



JQA-EM0202

# Best Value for Your Applications

Yaskawa Electric Corporation is here to provide “The Answers” for your company.

Our number one priority at Yaskawa Electric Corporation is to always keep the customer’s perspective in mind by leading the industry in meeting demands with uncompromising quality and trust.

Our new GA700 carries on the proud tradition of our product concepts: Flexible, Easy, Sustainable.

With a highly efficient, flexible motor control, powerful and extendable functionality along with a broad power range, the GA700 is the drive of choice for almost any task.





## CONTENTS

Features	4
Product Lineup	14
Catalog Code / Model Number	15
Basic Instructions	16
Model Selection	19
Standard Specifications	20
Standard Connection Diagram	24
Terminal Specifications	28
Dimensions	32
Fully-Enclosed Design	36
Peripheral Devices and Options	38
Application Notes	62
Global Service Network	71

By revolutionizing your facilities and machines, the GA700 will increase productivity, save energy efficiently, reduce total costs, with enhanced environmental compatibilities.





# Are You Maximizing the Use of Your Machines?

Yaskawa Electric Corporation has been developing motor controls for years, which will become the key to success and exceed all your expectations.

## Powerful Starting Torque without Encoder

When using an PM motor, it is possible to produce 200% torque at zero speed without the need for an encoder. This will make the machine more compact and reduce component costs. When utilizing induction motors using the Advanced Open Loop Vector Control method, the tension control of the winder can be achieved without encoders, which reduces wiring and improves reliability.



### Torque characteristics

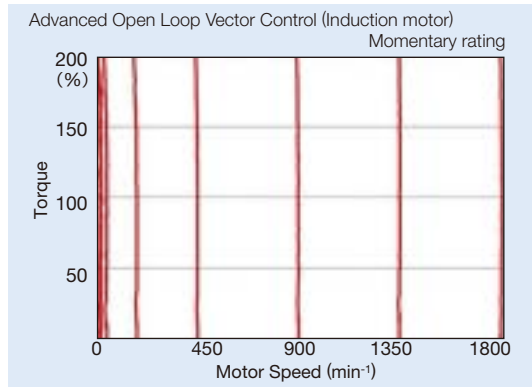
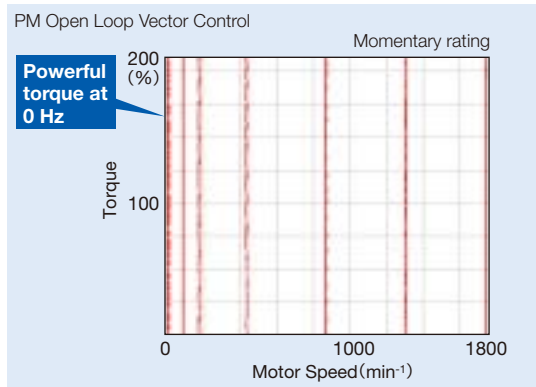

## Torque Control without Encoder

With the improved performance of Advanced Open Loop Vector Controls method, torque can be controlled without using encoders. Reliability can also be improved since encoders are not used

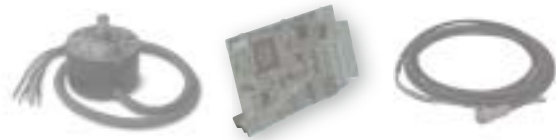

Encoder PG Option Card PG Cable  
Not needed

## EZ Open Loop Vector Control Tuning-less even for Synchronous Motors!

Yaskawa's NEW EZ Open Loop Vector Control can drive both synchronous motors and induction motors and eliminate complicated tuning processes. Simply input the information on the motor nameplate.

EZ Open Loop Vector Control can reduce start-up time. With the new EZ Open Loop Vector control, the GA700 can run a variety of these motor types without comprehensive tuning.\*

\* Refer to "The Fourth Energy Saving Choice" on page 5.



## High-speed Operation

With significant improvement in basic performance, induction motors and synchronous motors can operate up to 590 Hz\*.

Machines can be made more compact as a result of making motors gear-less and smaller.

\* Varies with control modes. Applicable to PM Open Loop Control and V/f Control modes.





# Are You Having Trouble with Power Efficiency?

Current trends include the use of drives for machines, the application of high-efficiency motors, and the use of regenerative energy. Now, you can achieve even better energy savings for drives with the use of new technologies that maximize motor efficiency.

## The Fourth Energy Saving Choice: Maximizing the Motor Efficiency

Higher energy savings can be achieved with new functions that monitor power consumption for maximum energy efficiency.

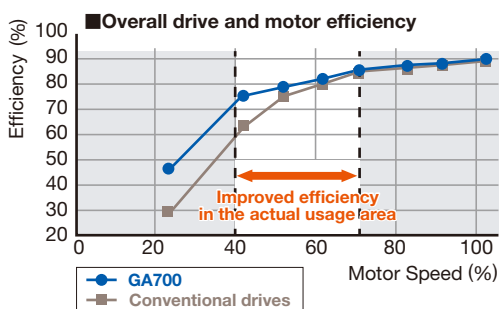

**Annual Performance**

- Annual power savings  
**Approx. 11,000 kWh**
- Annual CO<sub>2</sub> reduction effect:  
**Approx. 4.5 t**

**[Conditions]**

Application: Air-conditioning fan (high-efficiency motor IE3 applied)  
 Number of operating units: 7.5 kW  
 Motor Speed (Load factor): 40%  
 Number of air-conditioning fans: 10  
 Annual number of days of operation: 24h per day / 365 days per year  
 Control mode: GA700: EZ Open Loop Vector Control  
 Conventional drive: V/f Control  
 CO<sub>2</sub> coefficient: 0.412 (kg/kWh)

Valid only for synchronous motor control and EZ Open Loop Vector Control. This is an effective function for applications where load fluctuations are small (fans, pumps, etc.)

Note: Energy saving effects depend on the characteristics and performance of the motor.

### The First Energy Saving Choice: Using Drives

Energy savings with the use of an drive to control the air flow of the fan with the damper.

**Annual energy consumption**

Energy saving effect: **Approx. 18,600 kWh**

**[Conditions]** Drive  
 Application: Fan Load factor: 40 per  
 Hours of operation: 12 hours/300 days Motor capacity: 7.5 kW

### The Second Energy Saving Choice: Applying High Efficiency Motors

Energy savings with the application of a high-efficiency motor (IE3 / IE4).

**Annual energy consumption**

Energy saving effect: **Approx. 350 kWh**

**[Conditions]** Drive  
 Application: Fan Load factor: 40 per  
 Hours of operation: 12 hours/300 days Motor capacity: 7.5 kW

### The Third Energy Saving Choice: Usage of Regenerative Energy

Return the regenerative energy that has been wasted as heat in the braking resistor to the power supply for energy savings (when installed with the energy saving unit: D1000 or R1000).

**Braking Resistance System**

Drive energy → Drive → Motor → Heat (wasted)

**Power Source Regeneration System**

Drive energy → Drive → Motor → Regenerative energy → R1000 → Power Source

**Annual energy consumption**

Energy saving effect: **Approx. 5,500 kWh**

**[Conditions]**  
 Application: 10t crane  
 Load factor: 10 per day  
 Hours of operation: 12 hours/300 days  
 Motor capacity: 7.5 kW

Example using the Power Regenerative Unit R1000

### Simulation of Energy Saving Effects

You can monitor the investment effectiveness of energy savings when using a drive for a fan/pump or when adopting the various power supply regeneration methods.

\* You can download Drive Select from Yaskawa's product and technical information website (<http://www.e-mechatronics.com>).





# Do You Want to Reduce Costs?

To minimize initial investment, the functions of the peripheral devices are incorporated into the GA700. This eliminates the need for these devices, and saves space, wiring, and labor.

## Built-in Power Supply for the Sensor

Separate power supply not required because the drive provides a 24 Vdc output (150 mA) for external sensors.

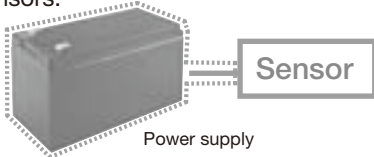

## 24 Vdc Control Power Input Terminal Standard Equipped

Backs up control power supply without the need for additional options.

## Braking Transistor Built-in

Eliminates the need for a separately mounted braking unit. Correspondence:  
200 V-class up to 37 kW (ND)  
400 V-class up to 75 kW (ND)

## DC Reactor Built-in

A DC reactor minimizes harmonic distortion. (Corresponds to 200 V class/400 V class 22 kW (ND) or more)

## EMC Filter (C2, C3) Built-in\*

\* Factory option

## High Performance Control Even Without an Encoder

## Horizontal Placement\*

Choice of horizontal or vertical placement of the drive to save space (for up to 200 V class/400 V class 75 kW (HD)).

Note: Adequate airflow must be provided and derating must be considered.

\* Under development

## Control Panel Not Required for IP55 Compatible Lineup\*

Can be installed as a single unit because the protective structure is IP55 compatible.

IP55: The IP Code in JIS must be "dust/jet-proof".

\* Factory option (under development)



## Reduction in the Number of Peripheral Devices

With the enhanced functions of the DriveWorksEZ programming tool, timers and relays are unnecessary.

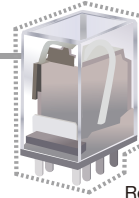

Relay

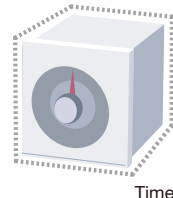

Timer

## Oscilloscope Function

With the improved oscilloscope function performance for the DriveWizard support tool, adjustments can be made without the need for external measuring instruments.

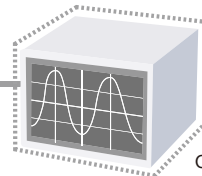

Oscilloscope

## Voltage/Current Switching Analog Output

Conversion circuit is not required for the analog output voltage of 0 to 10 V and electric current of 4 to 20 mA.



Converter

## SIL3\* Correspondence STO Standard Equipped

Two contactors are no longer needed.

\* Safety performance measurement under IEC/EN61508

## Compressor Installation Example

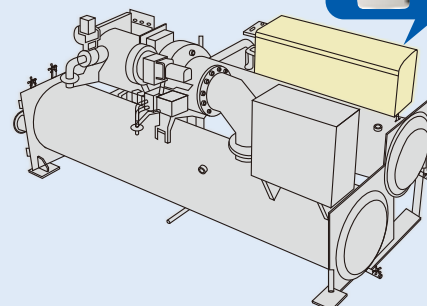



# Are you ready for the IoT?

Yaskawa offers option cards that are compatible with major industrial networks.

## Gateway Connection System

A maximum of five drives can be controlled with one communication card by converting the industrial network protocol to RS-485.

We recommend this system for fans, pumps, compressors and other devices that require multi-axis control.

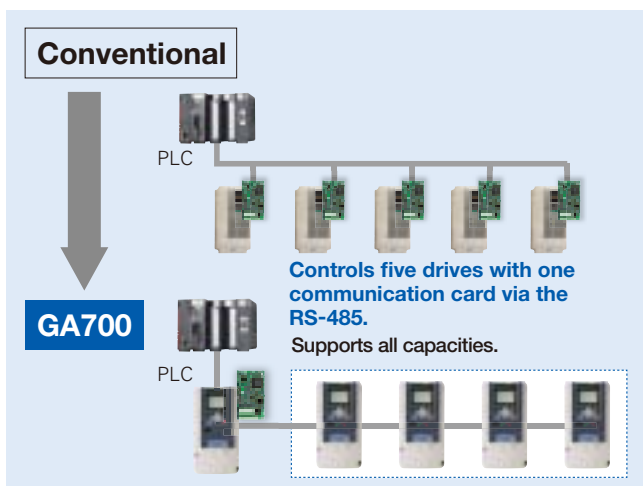

## Enhanced Communication Option Card

A variety of field networks, including MECHATROLINK-II, MECHATROLINK-III, PROFIBUS-DP, DeviceNet, CC-Link, CANopen, LONWORKS, including Industrial Ethernet, such as EtherNet/IP, can be supported with the use of one communication option card.

Note: Product names are registered trademarks of the respective owners.

## Monitor Output of Various Types of Data

Various data can be monitored via a communications network.

By constantly monitoring this data, you can visualize the factory. Values set to the parameters can be output as multi-function digital output.



## Flexibility Improvement of I/O

The PG option cards and input/output option cards for the 1000 series can be used.

DI-A3 input terminals that are conventionally used as digital frequency reference cards can also be used as multi-function input terminals.



# Do you have a need to Customize Your Drive?

## Equipped with Programming Tool DriveWorksEZ as Standard

Drives can be easily customized to suit the needs of customers with a drag-and-drop operation using a PC. Special operations and new detection functions, such as compressor pressure sensor-less control, conveyor vibration detection, and diagnosis of abnormal symptoms, such as fan clogging detection, can be programmed.



**Program Capacity Expanded!**

**Number of connections: 200**

Function Blocks: 419\*

Note: For DriveWorksEZ Pro.  
Please contact us for more information on DriveWorksEZ Pro.

### ■ Program Detection Function

Ex.) Detection function for monitor pulsations or deterioration in machine performance (machine torque pulsation detection)

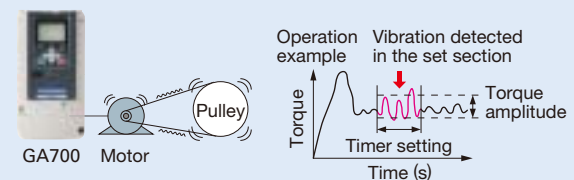

## Registration of Favorite Monitors

A maximum of 12 monitors can be registered.

Registered monitors can be displayed at any time with a simple keystroke.





# Does it Take a Long Time to Setup and Recover from Malfunctions?

The updated interactive start-up wizard function and redesigned keypad have significantly reduced time required for setup and increases uptime.

Downtime: Non-operating time due to equipment problems.

## Confirmation of Malfunctions Without the Main Circuit Power Supply

By externally supplying 24 Vdc control power, you can safely perform recovery work and confirm malfunctions without applying main circuit power.

## Set Parameters Without the Main Circuit Power Supply

With the USB connection of the drive and the PC, parameters can be set and edited in advance even when unable to prepare the main circuit supply.

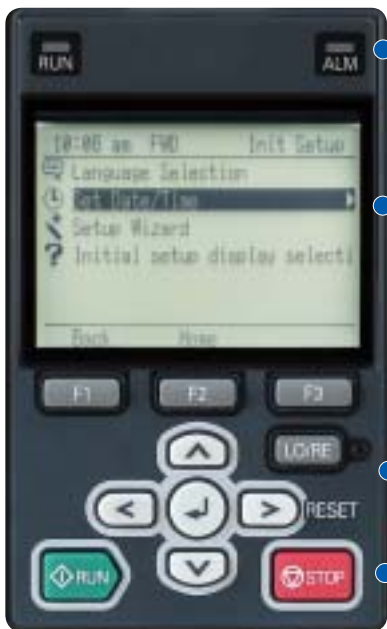

## Built-in Clock Functions

Easily identify the time of the malfunction with the built-in clock function.

Note: Requires a Hitachi Maxell "CR2016 Lithium Manganese Dioxide Battery" or equivalent.

## microSD Slot\*

Save log data to the microSD card. Saved data can be displayed as a waveform with the "DriveWizard" support tool,\* which helps you to understand what malfunction has occurred and simplifies analysis.

\* Waveform displays in the DriveWizard support tool are under development. Currently, Excel must be used to read and access this data.



## Capable of Storing Parameters of the Four Drives

The keypad can now store the parameters of up to four drives.

## Automatic Parameter Backup Function

Even if there is a problem with the drive, you can remove the keypad and copy the parameters using the automatic parameter backup function.

## European Terminals

European terminals are installed on the main circuit terminal.

Significant reduction in work hours because crimp terminal and crimping operation are now unnecessary.



Compatible Models:  
GA70A2004 to 2211  
(200 V class 0.4 to 45 kW (HD))  
GA70A4002 to 4168  
(400 V class 0.4 to 75 kW (HD))

Note: Screw terminals are used in models other than those listed here.

For use of the tools, see P.29. Screw terminal options, cable clamp options is under development.

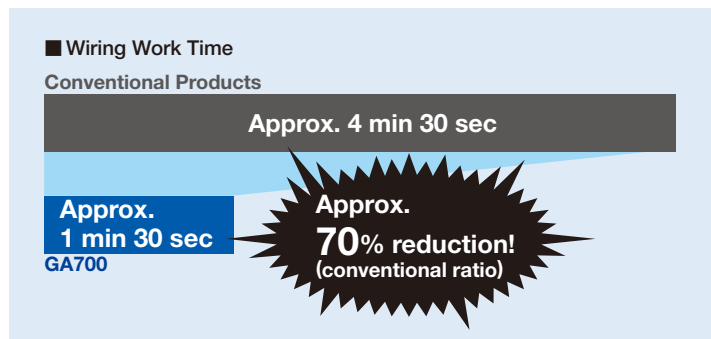

Conditions

When wiring input terminals R, S, and T and output terminals U, V, and W:  
Conventional products: Crimping and wiring work for screw terminals  
GA700: Wiring work for European terminals



## Equipped with Setup Wizard Function

Complete initial settings by responding to the questions that appear on the keypad.

● Parameters Set using the Setup Wizard Function

- Frequency reference source
- Run command source
- Motor class
- Maximum frequency
- Stopping method
- Input signal level
- Duty rating
- Control mode
- Input/output setting
- Acceleration/deceleration time etc.

10:00 FWD wizard  
would you like to apply the parameter settings?  
No  
Yes

Back Home

10:00 FWD wizard  
Pending Parameter Changes  
Control Method Selection  
A1-02 3 (2)  
Frequency Reference Selection 1  
b1-01 0 (1)

Back Home

10:00 FWD wizard  
Select run reference source (Start / Stop method)  
Keypad  
Digital Input  
Memobus/Modbus Communications  
Option PCB

Back Home

10:00 FWD Init Setup  
Language Selection  
Set Date/Time  
Setup Wizard  
Show Initial Setup Screen

Back Home

1 Select "Setup Wizard" from the initial setting.

2 Select the item you want to set. Follow the instructions on the keypad.

3 Check the modified parameters and select "Next".

4 Select "Yes" and settings are complete.



## LED Status Ring

You can check the operating conditions of the drive at a glance even remotely.



## Reduced Installation Space

45% reduction in comparison with conventional drives. You can design a compact control panel. (ex. 400 V class 110 kW)

Note: The size of the reduced installation space will vary depending on capacity.



## Bell-Shaped Holes

Easily installed on walls.



## Removable Terminal Block

Even if you are installing the drive in a small, narrow space, you can remove the terminal block and wire work where you have more space. In addition, if a drive malfunctions, the terminal board can be attached to a new replacement drive without removing the wires.



## Side-by-Side Installation

Side-by-side installation allows for a more compact design of the control panel.

Compatible Models:  
GA70A2004 to 2082 (200 V class 0.4 to 18.5 kW (HD))  
GA70A4002 to 4044 (400 V class 0.4 to 18.5 kW (HD))

(ex. 200 V class 0.4 kW)

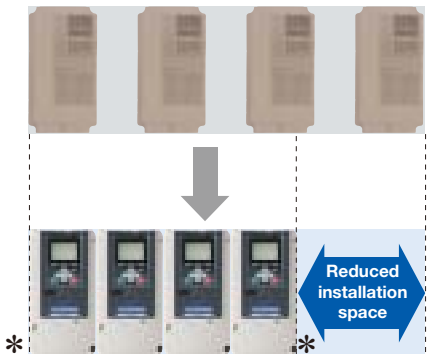

\* At least 30 mm of space is needed if installed near a wall.  
Note: Derating must be considered.



# Is Too Much Time Required When There is a Problem?

There has been significant improvements in maintainability with linkages to smartphone applications and PC support tools via cloud management.

## Support Tool “DriveWizard”

Wireless connection and cloud management through smartphones have made maintenance simple and easy. Equipped with various monitors, parameter editing, pattern operation, and oscilloscope function, adjustment and maintenance work for the drive can be executed more easily.



## Smartphone Application “DriveWizard Mobile”

New form of support utilizing the smartphone such as cloud management of the wireless connection and parameters of the drive.

### [ Parameter Management via Cloud ]

Parameters can be saved and read using the cloud.

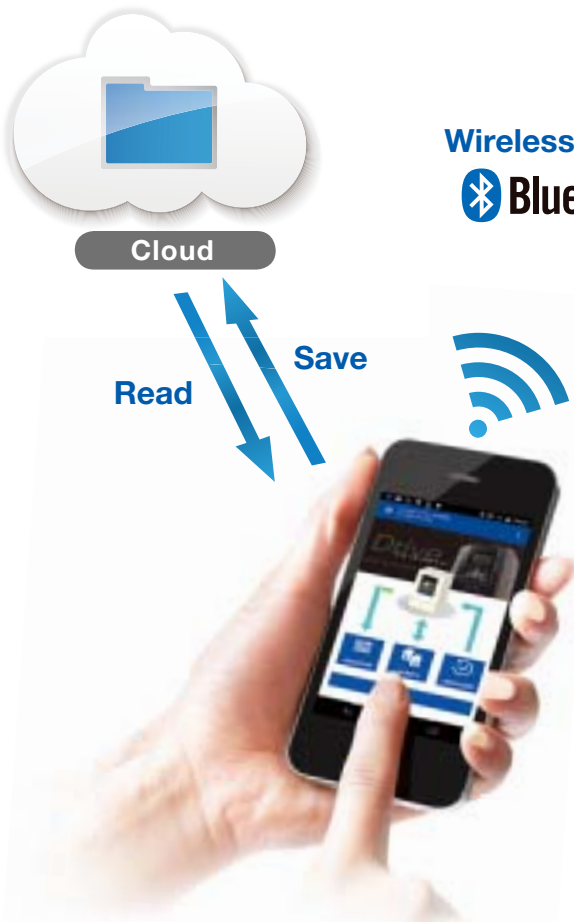

Wireless Access  
**Bluetooth**



Press Machine

**Drive**

### [ Access From Distance ]

You can access the drives remotely without opening any panels.

Note: “Bluetooth®” is a trademark of Bluetooth SIG, Inc. USA.

**Smartphone DriveWizard Mobile (exclusive app)**

### [ Parameter Setting Change/Drive Operation ]

- Easy to change the parameter settings.
- Operational status can be viewed in real time.
- Quick access to troubleshooting information.

## Variety of Functions and Services of the DriveWizard Mobile



Change parameter settings



Monitor display



Troubleshoot

Download DriveWizard Mobile at Android terminal content providing service, Google Play Store, for free. The Google Play Store hyper-link is available at the Yaskawa's product and technical information website (<http://www.e-mechatronics.com>).

Note: "Android" and "Google Play" are trademarks/registered trademarks of Google Inc.

## Complete After Sales Services

Call center and after service division offer support to our customers, seven days a week, 365 days a year.

## Deliver According to the Customer's Request

Drives can be customized according to your specifications.

- Shipped after installing option to the drive at factory.
- Terminal board with multi-function relay outputs

Multi-Function Photocoupler Output Type C (Standard)	Multi-Function Digital Output Type A
Relay: 2, Photocoupler: 2	Relay: 3, Photocoupler: 0

- Optional LED keypad  
Five-digit displaying keypad.
- Optional LCD Keypad with Built-in Bluetooth Interface

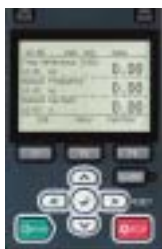

LCD keypad (standard)  
(JVOP-KPLCA04AAA)



LED keypad  
(JVOP-KPLEA04AAA)



LCD Keypad with Built-in  
Bluetooth Interface  
(JVOP-KPLCC04AAA)

Contact Yaskawa for details.



# Struggling with Standards and Adapting Your Products to be Environmentally Friendly?

The GA700 is compliant with international standards and designed to support various applications.

## International Standards



### International Standards

Name	Country
UL/cUL	U.S.A
CSA*1	Canada
CE*2	Europe
RCM *1,*2	Australia

### Vessel Standards

Name	Country
NK*1	Japan
DNV GL*1	Germany/Norway
ABS*1	U.S.A
BV*1	France
CCS*1	China
KR*1	South Korea

Products used in ships must be reliable and durable to withstand the harsh environmental conditions. The acquisition of the standard authentication from the corresponding countries are required.

**Others**  
RoHS directive compliant

\*1: Under application  
 \*2: Please use EMC filter.  
 (Select GA700 EMC built-in model, or use external EMC filter together.)  
 For CE and RCM Marking compliant models, refer to GA700 Technical Manual.

## Wide range of protection for various environmental specifications (or requirements)

### [ IP55 Compatible\* ]

Able to be installed in harsh environments because there are no control panels. More variation in installment locations.



IP55: The IP Code in JIS must be "dust/jet-proof".  
 \* Factory option (under development)

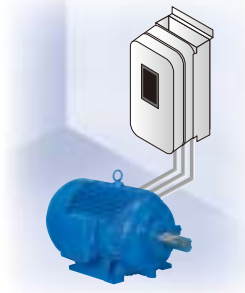

### [ Varnish-Coated Printed Circuit Board ]

The printed circuit board is treated with varnish as standard and can be used under harsh environmental conditions. (IEC 60721-3-3: 3 C2, 3 S2)



### [ Resolver Compatible ]

The GA700 is compatible with rotary resolvers that have higher environmental resistance than encoders.  
 Note: Option card is required.

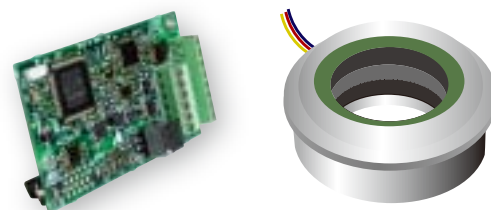

### [ Resistant to vibration, gas, moisture, dust, and oil. ]

Note: Factory option





# Is Your Equipment Reliable Enough?

The GA700 will continue to run your production lines even if there is a sudden power failure. With the life diagnostic prediction, preventive maintenance of life parts can be performed at the perfect time.

## Momentary Power Loss Countermeasures

Induction motors and synchronous motors with encoderless control can be controlled with momentary power loss countermeasures.

### [ Speed Search Function ]

Easy restart by searching the rotational speed of the motor when coasting. Ideal for machines with a rotating body such as fans and blowers.



### [ Momentary Power Loss Recovery to continue operation through a 2-s power loss.\* ]

- The GA700 automatically restarts the motor and keeps the application running in the event of a power loss.
- Easy transition to SEMI (Semiconductor Equipment and Materials International).
- Reduction of special equipments such as UPS (Uninterruptible power supply).

\* A momentary power loss recovery unit (option) is required for certain capacities.

### [ KEB Function ]

The GA700 is equipped with a function called the KEB (Kinetic Energy Back-up), which allows the drive to quickly and safely decelerate and stop without requiring the motor to be in free run when there is a power loss. It is ideal for machines that require power loss measures, such as machine tool spindle motors and film production lines. Continuous operation is possible without requiring the motor to be in free run during a momentary power loss. Emergency stop can also be selected.



## Standard Correspondence to SIL3 Without a Contactor

STO from two-terminal input (safety shut-off torque) is equipped as standard.

Complies with IEC/EN61508 SIL3 and ISO13849-1 Cat.3 PLe.

With this function, a high degree of safety can be built without additional equipment, such as an electromagnetic contactor. Saves wiring and space.

### Conventional

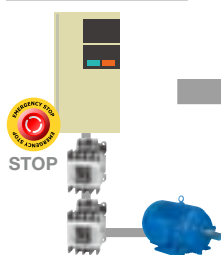

### GA700



## IP20 Supports All Capacities

The IP20 can be used with all capacities. Since there is no risk of exposure to high-voltage sections of the main circuit, additional safety measures do not need to be taken, such as installing a terminal cover inside the panel.

## Automatic Parameter Backup Function

Even if there is a problem with the drive, you can remove the keypad and copy the parameters using the automatic parameter backup function.

## Long Life

With the selection of long-life parts for fans, capacitors, and relays, a design life of 10 years has been achieved.

Note: The value was measured under an ambient temperature of 40 °C (open chassis type panels), load factor of 80%, and 24-hour continuous operation. The value varies depending on the conditions of use.

## Performance Life Monitors

With performance life monitors, the approximate maintenance period of parts can be output as an alarm signal to notify users in advance.

In addition, you can monitor the state of deterioration of the parts so that a maintenance plan can be easily developed.

### ■ GA700 outputs the alarm signal to the PLC controller



## Minimum Heat Generation (when using energy saving unit: D1000, R1000)

Regenerative energy that has conventionally been wasted as heat can be effectively used. The GA700 can minimize the generation of heat and avoid issues caused by heat in surrounding equipment.

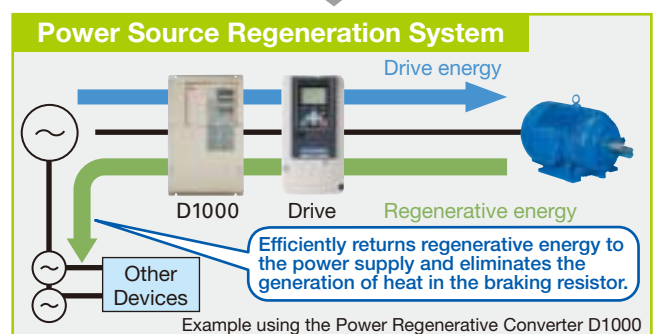
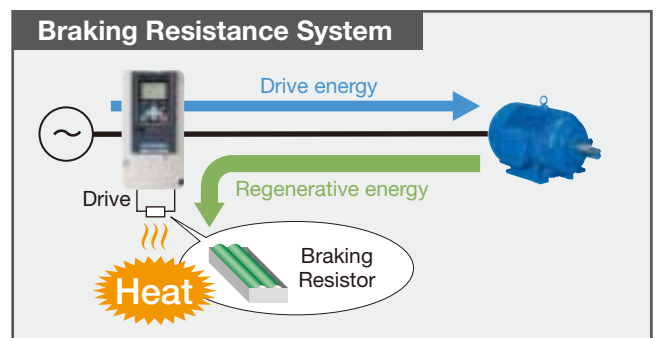

# Product Lineup

Motor Capacity kW	Three-Phase 200 V Class				Three-Phase 400 V Class			
	Heavy Duty		Normal Duty		Heavy Duty		Normal Duty	
	Catalog Code GA70A	Rated Output	Catalog Code GA70A	Rated Output	Catalog Code GA70A	Rated Output	Catalog Code GA70A	Rated Output
0.4	2004	3.2 A			4002	1.8 A		
0.75	2006	5 A	2004	3.5 A	4004	3.4 A	4002	2.1 A
1.1	2008*	6.9 A	2006	6 A				
1.5	2010	8 A	2008	8 A	4005	4.8 A	4004	4.1 A
2.2	2012	11 A	2010	9.6 A	4007	5.5 A	4005	5.4 A
3	2018	14 A	2012	12.2 A	4009	7.2 A	4007	7.1 A
3.7	2021	17.5 A	2018	17.5 A	4012	9.2 A	4009	8.9 A
5.5	2030	25 A	2021	21 A	4018	14.8 A	4012	11.9 A
7.5	2042	33 A	2030	30 A	4023	18 A	4018	17.5 A
11	2056	47 A	2042	42 A	4031	24 A	4023	23.4 A
15	2070	60 A	2056	56 A	4038	31 A	4031	31 A
18.5	2082	75 A	2070	70 A	4044	39 A	4038	38 A
22	2110	88 A	2082	82 A	4060	45 A	4044	44 A
30	2138	115 A	2110	110 A	4075	60 A	4060	59.6 A
37	2169	145 A	2138	138 A	4089	75 A	4075	74.9 A
45	2211	180 A	2169	169 A	4103	91 A	4089	89.2 A
55	2257	215 A	2211	211 A	4140	112 A	4103	103 A
75	2313	283 A	2257	257 A	4168	150 A	4140	140 A
90	2360	346 A	2313	313 A	4208	180 A	4168	168 A
110	2415	415 A	2360	360 A	4250	216 A	4208	208 A
132					4296	260 A	4250	250 A
160					4371	304 A	4296	296 A
200					4389	371 A	4371	371 A
220					4453	414 A	4389	389 A
250					4568	453 A	4453	453 A
315					4675	605 A	4568	568 A
355					4726	642 A	4675	675 A
400					4810	726 A	4726	726 A
450					4930	810 A	4810	810 A
500							4930	930 A
560					4H12	1090 A		
630							4H12	1200 A

Note: The GA70A 4726 to GA70A 4H12 are under development.

\* Available in Japan only

# Model Number

Drives can be customized according to your specifications.

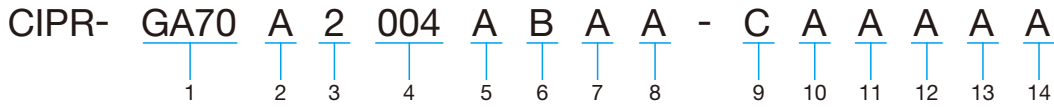

No	Description
1	Product series
2	Region code · A: Japan · T: Asia (Singapore, Taiwan)
3	Input power supply voltage · 2: 3-phase AC 200 V Class · 4: 3-phase AC 400 V Class
4	Output Current Note: Indicates the rated output current of the Normal Duty rating rounded off to the nearest whole number.
5	EMC noise filter · A: No internal EMC filter (Standard) · B: Internal category C3 EMC filter · C: Internal category C2 EMC filter
6	Protection Design · B: IP20 (Standard) · F: IP20, UL Type 1
7	Environmental specification · A: Standard · K: Gas-resistant · M: Humidity-resistant and dust-resistant · N: Oil-resistant · P: Humidity-resistant, dust-resistant, and vibration-resistant · R: Gas-resistant and vibration-resistant · S: Vibration-resistant · T: Oil-resistant and vibration-resistant Note: Drives with these specifications do not guarantee complete protection for the environmental conditions indicated.
8	Design revision order
9	Control circuit terminal board · A: Relay output/screw clamp terminal board type · C: Photocoupler output/screw clamp terminal board type (Standard)

No	Description
10	Option card (connector CN5-A) · A: No option card (Standard) · D: AI-A3 (Analog Input) · E: DI-A3 (Digital Input) · F: SI-C3 (CC-Link) · G: SI-ET3 (MECHATROLINK-III) · H: SI-N3 (DeviceNet) · J: SI-P3 (PROFIBUS-DP) · K: SI-T3 (MECHATROLINK-II) · M: SI-S3 (CANopen) · N: SI-ES3 (EtherCAT)* · P: SI-EM3 (Modbus TCP/IP)* · R: SI-EN3 (EtherNet/IP)* · S: SI-EP3 (PROFINET)*
11	Option card (connector CN5-B) · A: No option card (Standard) · B: AO-A3 (Analog Monitor) · C: DO-A3 (Digital Output)
12	Option card (connector CN5-C) · A: No option card (Standard) · U: PG-B3 (Complementary Type PG) · V: PG-X3 (Motor PG Feedback Line Driver Interface) · W: PG-F3 (encoder interface (for Endat and HIPERFACE)) · Z: PG-RT3 (Motor Feedback Resolver TS2640N321E64 Interface)
13	Keypad · A: LCD keypad (Standard) · B: LCD keypad (humidity-resistant and dust-resistant) · D: Bluetooth LCD Keypad · E: Bluetooth LCD Keypad (humidity-resistant and dust-resistant) · F: LED keypad · G: LED keypad (humidity-resistant and dust-resistant)
14	Special applications A: Standard

\*: Contact Yaskawa for EtherCAT, Modbus TCP/IP, EtherNet/IP and PROFINET.

# Catalog Code

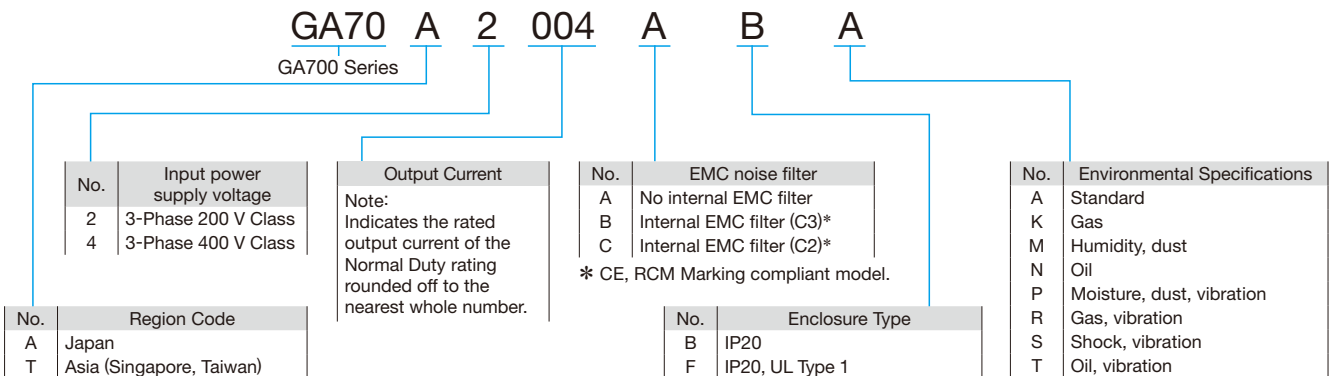

Note: Drives with these specifications do not guarantee complete protection for the environmental conditions indicated.

# Basic Instructions

## Outstanding operability and quick setup

### Keypad Names and Functions

#### ① RUN LED

Lit while the drive is operating the motor.

#### ⑤ ALM LED

The drive lights up if a fault is detected.

Flashes when minor faults, tuning errors and operational errors occur.

#### ⑦ LO/RE LED

Lit: When the keypad is selected for Run command and frequency reference control (LOCAL).

Off: When a device other than the keypad is selected for Run command and frequency reference control (REMOTE).

#### ⑩ LED Status Ring

The corresponding lamp lights depending on the operation status.

#### ④ RUN Key

Starts the drive in LOCAL mode.

#### ⑥ LO/RE Selection Key

Switches drive control between the keypad (LOCAL) and an external source (REMOTE) for the Run command and frequency reference.

#### ⑧ STOP Key

Stops drive operation.

#### ⑨ Com port

For connecting to a PC (DriveWizard or DriveWorksEZ), a USB copy unit or a LCD keypad.

#### ⑪ QR cord

Import the dedicated smartphone application "DriveWizard Mobile" and use it to retrieve product information.



#### ② Function Keys

F1, F2, F3

The functions of the function key depend on the menu that is being displayed.

The name of each function appears in the lower half of the display window.

#### ③ Display Operation Keys

LEFT Arrow Key

- Moves the cursor to the left.
- Returns to the previous screen.

UP Arrow Key / DOWN Arrow Key

- Scrolls up to display the next item.
- Scrolls down to display the previous item.
- Selects parameter numbers.
- Increments setting values.
- Decrements setting values.

RIGHT Arrow (RESET) Key

- Moves the cursor to the right.
- Proceeds to the next screen.
- Resets the drive to clear a fault.
- Used as the start key in Auto-Tuning Mode.

ENTER Key

- Inputs parameter numbers and setting values. Press to enter values, edit parameters and set the control mode.
- Switches between displays with selection of menu items.

Note: QR code is a registered trademark of DENSO WAVE INCORPORATED.

### Keypad LED

Indicator LED	ON	Flashing	Flashing Quickly	OFF
	Motor running.	<ul style="list-style-type: none"> <li>• The motor is performing ramp to stop.</li> <li>• The Run command was inputted when the frequency reference was 0 Hz</li> </ul>	<ul style="list-style-type: none"> <li>• With a Run command inputted from an external command when the Run command source was in LOCAL, the Run command source switched to REMOTE.</li> <li>• When the drive was not in the Drive Ready (READY) state, a Run command was inputted from an external command.</li> <li>• An emergency stop command has been inputted.</li> <li>• The Safe Disable input function was running and the drive output was shut off.</li> <li>• When the Run command source was REMOTE, the STOP key on the keypad was pressed and the motor was stopped.</li> <li>• The power supply for the drive is turned on when the Run command is inputted from an external source.</li> </ul>	Drive is stopped.
	A fault was detected.	<ul style="list-style-type: none"> <li>• Minor fault was detected.</li> <li>• Operation error was detected.</li> <li>• Auto-Tuning was detected.</li> </ul>	—	Normal operation
	Sets the Run command source to the keypad (LOCAL).	—	—	Sets the Run command source to a non-keypad external command (REMOTE).

### How the RUN light works:

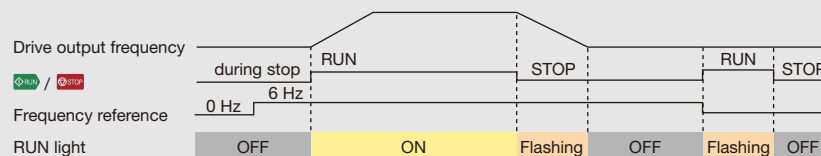



## LED Status Ring LED

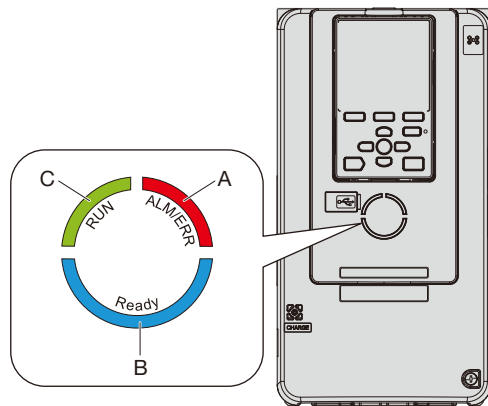

LED Status Ring	State	Content
A 	Lit	The drive detected a fault.
	Flashing	The drive has detected: <ul style="list-style-type: none"> <li>• an error</li> <li>• an oPE</li> <li>• an error during Auto-Tuning.</li> </ul> Note: If the drive detects a fault and an error at the same time, this LED will be lit to indicate the fault.
	OFF	The drive is in normal operation. There are no alarms or faults present.
B 	Lit	The drive is operating or is ready for operation.
	Flashing	When the drive is in STo [Safe Torque Off] mode. The drive is in STo [Safe Torque Off] mode.
	OFF	<ul style="list-style-type: none"> <li>• The drive detected a fault.</li> <li>• There is no fault and the drive received an operation command, but the drive cannot operate (such as when in Programming Mode, or when is flashing).</li> </ul>
C 	Lit	The drive is in regular operation.
	Flashing	<ul style="list-style-type: none"> <li>• The drive is decelerating to stop.</li> <li>• The drive was issued a Run command and the frequency reference is 0 Hz.</li> <li>• A DC injection braking command is input via a multi-function digital input terminal while the drive is stopped.</li> </ul>
	Flashing Quickly	<ul style="list-style-type: none"> <li>• Entering a Run command via the input terminals, then switching to REMOTE while the drive is set to LOCAL.</li> <li>• Entering a Run command via the input terminals when the drive is not in Drive Mode.</li> <li>• Entering a Fast Stop command.</li> <li>• The safety function shuts off the drive output.</li> <li>• Pushing STOP on the keypad while the drive is running in REMOTE mode.</li> <li>• Setting b1-17 = 0 [Run Command at Power Up = Accept existing RUN command] and powering up the drive while the Run command is active.</li> </ul>
	OFF	The motor is stopped.

# Basic Instructions (continued)

## Keypad Example

Turn the power on

10:00	Fwd	Rdy	Home
Freq Reference (AI)			0.00
U1-01 Hz			0.00
Output Frequency			0.00
U1-02 Hz			0.00
Output Current			0.00
U1-03 A			
Jog	Menu	FWD/REV	

HOME

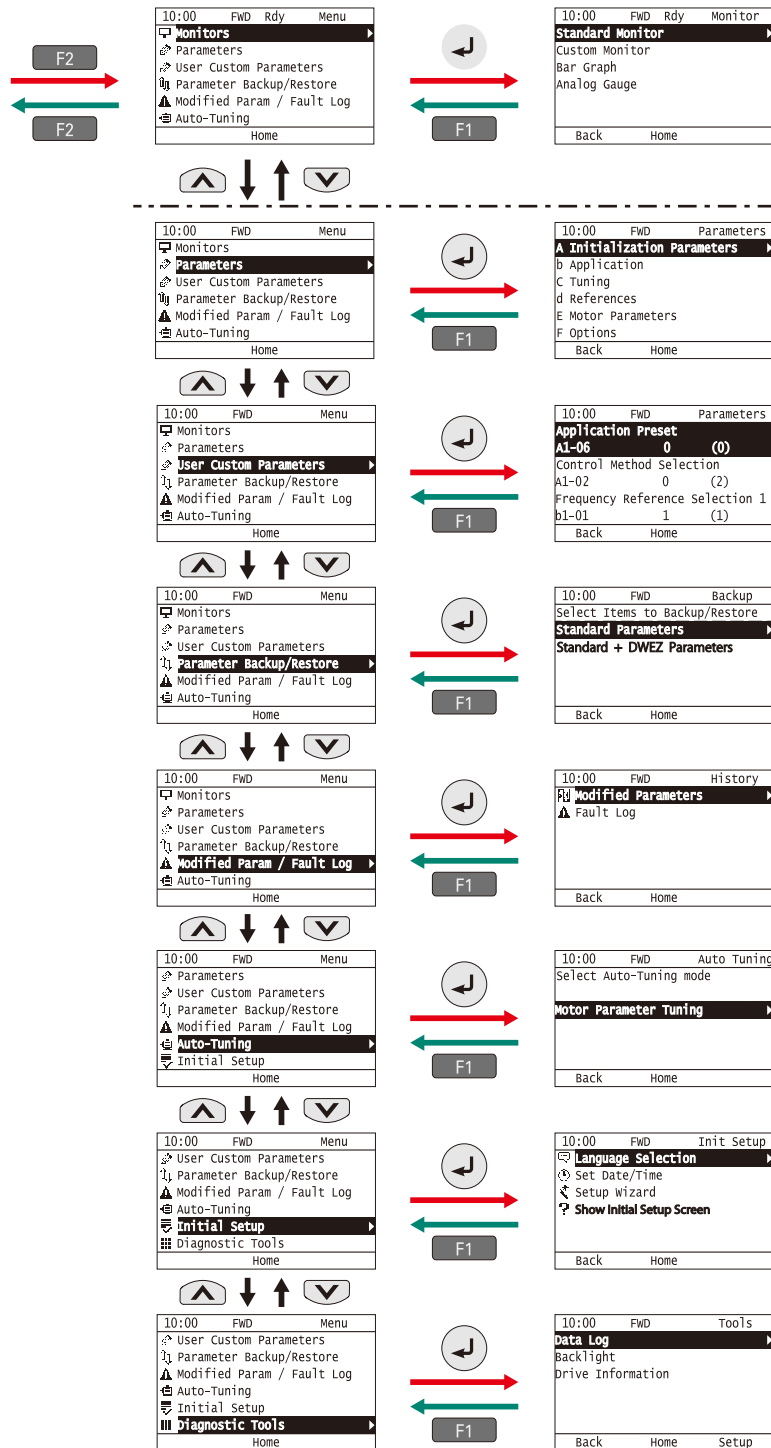

Drive Mode

Program Mode

Note:

- Energizing the drive with factory defaults will display the initial start-up screen. Press F2 Key (Home) to display the HOME screen.  
–To prevent the drive from displaying the initial start-up screen, Select [No] from the [Show Initial Setup Screen] setting.
- Press Left Arrow Key from the Home screen to display the monitors.
- When U1-01 [Freq. Reference] is displayed on the Home screen in LOCAL mode, press ENTER Key to change parameter d1-01 [Frequency Reference].
- The keypad will display [Rdy] when the drive is in Drive Mode and ready to accept a Run command.

- The drive will not accept a Run command while in Programming Mode. Set b1-08 [Run Command Select in PRG Mode] to accept or reject a Run command from an external source while in Programming Mode.  
–Set b1-08 = 0 [Do not accept RUN at Programming] (default) to reject the Run command from an external source while in Programming Mode.  
–Set b1-08 = 1 [Accept RUN while Programming] to accept the Run command from an external source while in Programming Mode.  
–Set b1-08 = 2 [Allow Programming only at Stop] to block changes from Drive Mode to Programming Mode while the drive is in operation.

# Model Selection

## Optimizing Control for Each Application

GA700 offers two separate performance ratings: Heavy Duty and Normal Duty.

Heavy Duty is capable of creating more powerful torque, while Normal Duty allows the drive to operate a larger motor.

Difference between load ratings:

	Heavy Duty Rating	Normal Duty Rating
Parameter settings	C6-01=0 (default)	C6-01=1
Overload tolerance	150% 60s	110% 60s
Carrier frequency	Low carrier frequency	Low carrier frequency (SwingPWM) *

\* Use Swing PWM to quiet undesirable motor noise generated when operating with a low carrier frequency. Available for models less than 450 kW.

### Heavy Duty Applications

● Applications



● Selecting a Drive

For a conveyor application using an 11 kW motor, select GA70A2056 and set it for Heavy Duty performance (C6-01=0: default).

Catalog code: GA70A2056

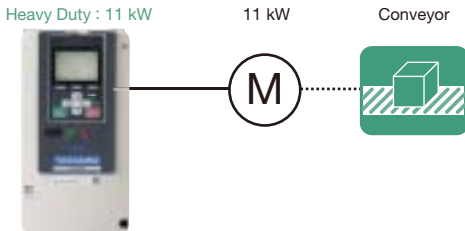

### Normal Duty Applications

● Applications



● Selecting a Drive

For a fan application using a 11 kW motor, select GA70A2042 and set it for Normal Duty performance (C6-01=1).

Catalog code: GA70A2042

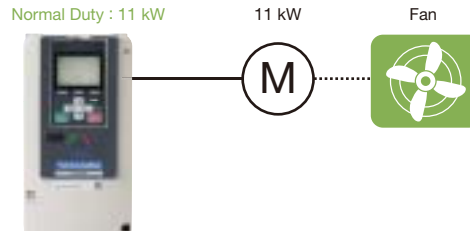

# Standard Specifications

Parameter C6-01 sets the drive for Heavy Duty (default) or Normal Duty performance.

## 200 V Class

HD: Heavy Duty, ND: Normal Duty

Catalog Code GA70A2:::		004	006	008	010	012	018	021	030	042	056	070	082	110	138	169	211	257	313	360	415		
Max. Applicable Motor Capacity*1	kW	HD	0.4	0.75	1.1	1.5	2.2	3	3.7	5.5	7.5	11	15	18.5	22	30	37	45	55	75	90	110	
		ND	0.75	1.1	1.5	2.2	3	3.7	5.5	7.5	11	15	18.5	22	30	37	45	55	75	90	110	–	
Input	Rated Input Current*2	A	HD	3.6	4.8	6.7	8.9	12.7	17	20.7	30	40.3	58.2	78.4	96	82	111	136	164	200	271	324	394
			ND	4.8	6.7	8.9	12.7	17	20.7	30	40.3	52	78.4	96	114	111	136	164	200	271	324	394	–
Output	Rated Output Current	A	HD	3.2	5	6.9	8	11	14	17.5	25	33	47	60	75	88	115	145	180	215	283	346	415
			ND	3.5	6	8	9.6	12.2	17.5	21	30	42	56	70	82	110	138	169	211	257	313	360	–
	Overload Tolerance	· HD Rating: 150% of rated output current for 60 s · ND Rating: 110% of rated output current for 60 s Note: Derating may be required for applications that start and stop frequently.																					
	Carrier Frequency	Derating the output current enables a maximum of 15 kHz to be set. (Derating the output current is not necessary for an ND rating of 2 kHz and an HD rating up to 8 kHz.)															Derating the output current enables a maximum of 10 kHz to be set. (Derating the output current is not necessary for an ND rating of 2 kHz and an HD rating up to 5 kHz.)						
	Max. Output Voltage	Three-phase 200 to 240 V Note: The maximum output voltage is proportional to the input voltage.																					
Max. Output Frequency	590 Hz The frequencies that can be set vary depending on the control mode used.																						
Measures for Harmonics	DC Reactor	External options												Built-in									
		Built-in												External options									
Braking Function	Braking Transistor	Built-in												External options									
EMC filter	EMC filter EN61800-3, C2/C3	Internal (factory option)																					
Power	Rated Voltage/ Rated Frequency	• Three-phase AC power supply 200 V to 240 V 50/60 Hz • DC power supply 270 V to 340 V																					
	Allowable Voltage Fluctuation	-15% to 10%																					
	Allowable Frequency Fluctuation	±5%																					
	Power Supply*3	kVA	HD	1.5	2.0	2.8	3.7	5.3	7.1	8.6	12.5	16.8	24.2	32.6	39.9	34.1	46.1	56.5	68.2	83.1	113	135	164
		ND	2.0	2.8	3.7	5.3	7.1	8.6	12.5	16.8	21.6	32.6	39.9	47.4	46.1	56.5	68.2	83.1	113	135	164	–	

\*1: The rated output current of the drive output amps should be equal to or greater than the motor rated current.  
 \*2: The value displayed is the input current when operating standard Yaskawa motors at the maximum applicable capacity with the rated load at the rated motor speed. This value may fluctuate based on the power supply side impedance, as well as the input current, power supply transformer, input side reactor, and wiring conditions.  
 \*3: Rated input capacity is calculated with a power line voltage of 240 V.

400 V Class

HD: Heavy Duty, ND: Normal Duty

Catalog Code GA70A4			002	004	005	007	009	012	018	023	031	038	044	060	075	089	103	
Max. Applicable Motor Capacity*1	kW	HD	0.4	0.75	1.5	2.2	3.0	3.7	5.5	7.5	11	15	18.5	22	30	37	45	
		ND	0.75	1.5	2.2	3.0	3.7	5.5	7.5	11	15	18.5	22	30	37	45	55	
Input	Rated Input Current*2	A	HD	1.9	3.5	4.7	6.7	8.9	11.7	15.8	21.2	30.6	41.3	50.5	43.1	58.3	71.5	86.5
			ND	2.5	4.7	6.7	8.9	11.7	15.8	21.2	30.6	41.3	50.5	59.7	58.3	71.5	86.5	105
Output	Rated Output Current	A	HD	1.8	3.4	4.8	5.5	7.2	9.2	14.8	18	24	31	39	45	60	75	91
			ND	2.1	4.1	5.4	7.1	8.9	11.9	17.5	23.4	31	38	44	59.6	74.9	89.2	103
Output	Overload Tolerance		· HD Rating: 150% of rated output current for 60 s · ND Rating: 110% of rated output current for 60 s Note: Derating may be required for applications that start and stop frequently.															
	Carrier Frequency		Derating the output current enables a maximum of 15 kHz to be set. (Derating the output current is not necessary for an ND rating of 2 kHz and an HD rating up to 8 kHz.)															
	Max. Output Voltage		Three-phase 380 to 480 V Note: The maximum output voltage is proportional to the input voltage.															
	Max. Output Frequency		590 Hz The frequencies that can be set vary depending on the control mode used.															
Measures for Harmonics	DC Reactor		External options										Built-in					
Braking Function	Braking Transistor		Built-in															
EMC filter	EMC filter EN61800-3, C2/C3		Internal (factory option)															
Power	Rated Voltage/ Rated Frequency		• Three-phase AC power supply 380 V to 480 V 50/60 Hz • DC power supply 510 V to 680 V															
	Allowable Voltage Fluctuation		-15% to 10%															
	Allowable Frequency Fluctuation		±5%															
	Power Supply*3	kVA	HD	1.5	2.8	3.7	5.3	7.1	9.3	13	17	24	33	40	34	46	57	69
ND			2.0	3.7	5.3	7.1	9.3	13	17	24	33	40	48	46	57	69	84	

Catalog Code GA70A4			140	168	208	250	296	371	389	453	568	675	
Max. Applicable Motor Capacity*1	kW	HD	55	75	90	110	132	160	200	220	250	315	
		ND	75	90	110	132	160	200	220	250	315	355	
Input	Rated Input Current*2	A	HD	105	142	170	207	248	300	373	410	465	584
			ND	142	170	207	248	300	373	410	465	584	657
Output	Rated Output Current	A	HD	112	150	180	216	260	304	371	414	453	605
			ND	140	168	208	250	296	371	389	453	568	675
Output	Overload Tolerance		· HD Rating: 150% of rated output current for 60 s · ND Rating: 110% of rated output current for 60 s Note: Derating may be required for applications that start and stop frequently.										
	Carrier Frequency		Derating the output current enables a maximum of 10 kHz to be set. (Derating the output current is not necessary for an ND rating of 2 kHz and an HD rating up to 5 kHz.)					Derating the output current enables a maximum of 5 kHz to be set. (Derating the output current is unnecessary for ND/HD rating up to 2 kHz)					
	Max. Output Voltage		Three-phase 380 to 480 V Note: The maximum output voltage is proportional to the input voltage.										
	Max. Output Frequency		590 Hz The frequencies that can be set vary depending on the control mode used.										
Measures for Harmonics	DC Reactor		Built-in										
Braking Function	Braking Transistor		Built-in			External options							
EMC filter	EMC filter EN61800-3, C2/C3		Internal (factory option)										
Power	Rated Voltage/ Rated Frequency		• Three-phase AC power supply 380 V to 480 V 50/60 Hz • DC power supply 510 V to 680 V										
	Allowable Voltage Fluctuation		-15% to 10%										
	Allowable Frequency Fluctuation		±5%										
	Power Supply*3	kVA	HD	84	113	136	165	198	239	297	327	370	465
ND			113	136	165	198	239	297	327	370	465	523	

\*1: The rated output current of the drive output amps should be equal to or greater than the motor rated current.

\*2: The value displayed is the input current when operating standard Yaskawa motors at the maximum applicable capacity with the rated load at the rated motor speed. This value may fluctuate based on the power supply side impedance, as well as the input current, power supply transformer, input side reactor, and wiring conditions.

\*3: Rated input capacity is calculated with a power line voltage of 480 V.

# Standard Specifications

## Common Specifications

Item	Specifications
Control Method	The following controls are selected by parameters. <ul style="list-style-type: none"> <li>· V/f Control</li> <li>· Closed Loop V/f Control</li> <li>· Open Loop Vector Control</li> <li>· Closed Loop Vector Control</li> <li>· Advanced Open Loop Vector Control</li> <li>· Open Loop Vector Control for PM</li> <li>· Advanced Open Loop Vector Control for PM</li> <li>· Closed Loop Vector Control for PM</li> <li>· EZ Open Loop Vector Control</li> </ul>
Maximum Output Frequency	<ul style="list-style-type: none"> <li>· Advanced Open Loop Vector Control, EZ Open Loop Vector Control: 120 Hz</li> <li>· Closed Loop V/f Control, Closed Loop Vector Control, Advanced Open Loop Vector Control for PM, Closed Loop Vector Control for PM: 400 Hz</li> <li>· V/f Control, Open Loop Vector Control, Open Loop Vector Control for PM: 590 Hz</li> </ul>
Frequency Accuracy (Temperature Fluctuation)	Digital reference: within $\pm 0.01\%$ of the max. output frequency ( $-10^{\circ}\text{C}$ to $+40^{\circ}\text{C}$ ) Analog reference: within $\pm 0.1\%$ of the max. output frequency ( $25^{\circ}\text{C} \pm 10^{\circ}\text{C}$ )
Frequency Setting Resolution	Digital reference: 0.01 Hz Analog reference: 1/2048 of the maximum output frequency setting (11 bit plus sign)
Output Frequency Resolution	0.001 Hz
Frequency Setting Resolution	Main frequency reference: -10 to +10 Vdc, 0 to 10 Vdc (20 k $\Omega$ ), 4 to 20 mA (250 $\Omega$ ), 0 to 20 mA (250 $\Omega$ ) Main speed reference : Pulse train input (max. 32 kHz)
Starting Torque	<ul style="list-style-type: none"> <li>· V/f Control: 150%/3 Hz</li> <li>· Closed Loop V/f Control: 150%/3 Hz</li> <li>· Open Loop Vector Control: 200%/0.3 Hz</li> <li>· Closed Loop Vector Control: 200%/0 min<sup>-1</sup></li> <li>· Advanced Open Loop Vector Control: 200%/0.3 Hz</li> <li>· Open Loop Vector Control for PM: 100%/5% speed</li> <li>· Advanced Open Loop Vector Control for PM: 200%/0 min<sup>-1</sup></li> <li>· Closed Loop Vector Control for PM: 200%/0 min<sup>-1</sup></li> <li>· EZ Open Loop Vector Control: 100%/1% speed</li> </ul> <p>Note: Drive capacity must be selected appropriately to obtain this starting torque under Open Loop Vector Control, Closed Loop Vector Control, Advanced Open Loop Vector Control, Advanced Open Loop Vector Control for PM, and Closed Loop Vector Control for PM.</p>
Speed Control Range	<ul style="list-style-type: none"> <li>· V/f Control 1:40</li> <li>· Closed Loop V/f Control 1:40</li> <li>· Open Loop Vector Control 1:200</li> <li>· Closed Loop Vector Control 1:1500</li> <li>· Advanced Open Loop Vector Control 1:200</li> <li>· Open Loop Vector Control for PM 1:20</li> <li>· Advanced Open Loop Vector Control for PM 1:100</li> <li>· Closed Loop Vector Control for PM 1:1500</li> <li>· EZ Open Loop Vector Control 1:100</li> </ul> <p>Note:            · Advanced Open Loop Vector Control for PM is valid when high frequency injection is enabled (n8-57=1).            · For Advanced Open Loop Vector Control for PM contact your Yaskawa or nearest agent when not using SSR1 series or SST4 series motors manufactured by Yaskawa Motor Co., Ltd.</p>
Zero Speed Control	Possible in Closed Loop Vector Control, Advanced Open Loop Vector Control for PM, and Closed Loop Vector Control for PM.
Torque Limit	Parameter settings allow separate limits in four quadrants in Open Loop Vector Control, Closed Loop Vector Control, Advanced Open Loop Vector Control, Advanced Open Loop Vector Control for PM, Closed Loop Vector Control for PM, and EZ Open Loop Vector Control.
Accel/Decel Time	0.0 s to 6000.0 s The drive allows four selectable combinations of independent acceleration and deceleration settings.
Braking Torque	Approx. 20% Approx. 125% with a dynamic braking option <ul style="list-style-type: none"> <li>• Short-time average deceleration torque                Motor capacity 0.4/0.75 kW: over 100%</li> <li>Motor capacity 1.5 kW: over 50%</li> <li>Motors 2.2 kW and larger: over 20%, Overexcitation Braking / High Slip Braking allow for approx. 40%</li> <li>• Continuous regenerative torque: Approx. 20%. Dynamic braking option allows for approx. 125%, 10% ED, 10 s</li> </ul> <p>Note:            • Catalog codes GA70□2004 to 2138 and 4002 to 4168 have a built-in braking transistor.            • Set L3-04 = 0 [Stall Prevention during Decel = Disabled] when using a regenerative converter, regenerative unit, braking unit, braking resistor, or braking resistor unit. The drive could possibly not stop within the specified deceleration time when L3-04 = 1 [General Purpose](default).            • Short-time deceleration torque refers to the torque required to decelerate the motor (uncoupled from the load) from the rated speed to zero. Actual specifications may vary depending on motor characteristics.            • Continuous regenerative torque and short-time deceleration torque for motors 2.2 kW and larger vary depending on motor characteristics.</p>
V/f Characteristics	Select from 15 predefined V/f patterns, or a user-set V/f pattern.
Main Control Functions	Torque Control, Droop Control, Speed/Torque Control switch, Feed Forward Control, Zero Servo Control, Momentary Power Loss Ride-Thru, Speed Search, Overtorque detection, torque limit, 17 Step Speed (max.), accel/decel switch, S-curve accel/decel, 3-wire sequence, Auto-Tuning (rotational, stationary), Dwell, cooling fan on/off switch, slip compensation, torque compensation, Frequency Jump, Upper/lower limits for frequency reference, DC Injection Braking at start and stop, Overexcitation Deceleration, High Slip Braking, PID control (with Sleep function), Energy Saving Control, MEMOBUS/Modbus communications. (RS-485/422, max. 115.2 kbps), Fault Restart, Application Presets, DriveWorksEZ (customized functions), Parameter Backup Function, Online Tuning, KEB, Overexcitation Deceleration, Inertia Tuning and ASR Tuning, Overvoltage Suppression, High Frequency Injection, etc.

	Item	Specifications
Protection Function	Motor Protection	Motor overheat protection based on output current
	Momentary Overcurrent Protection	Drive stops when output current exceeds 200% of the HD output current.
	Overload Protection	Drive stops after 60 s at 150% of rated HD output current and at 110% of rated ND output current. Note: The drive may trigger the overload protection function at 150% of the drive rated output in under 60 s if the output frequency is less than 6 Hz.
	Overvoltage Protection	200 V class: Stops when DC bus exceeds approx. 410 V 400 V class: Stops when DC bus exceeds approx. 820 V
	Undervoltage Protection	200 V class: Stops when DC bus exceeds approx. 190 V 400 V class: Stops when DC bus exceeds approx. 380 V
	Momentary Power Loss Ride-Thru	Stops when power loss is longer than approximately 15 ms (default setting). Continues operation if power loss is shorter than 2 s (depending on parameter settings). Note: 1. Stop time may be shortened depending on the load and motor speed. 2. Continuous operation time varies by drive capacity. Catalog codes 2004 to 2056 and 4002 to 4031 require a Momentary Power Loss Recovery Unit to continue operation through a 2 s power loss.
	Heatsink Overheat Protection	Thermistor
	Braking Resistance Overheat Protection	Overheat sensor for braking resistor (optional ERF-type, 3% ED)
	Stall Prevention	Stall prevention during acceleration/deceleration and constant speed operation
	Ground Fault Protection	Protection by electronic circuit Note: Protection may not be provided under the following conditions as the motor windings are grounded internally during run: Low resistance to ground from the motor cable or terminal block. Drive already has a short-circuit when the power is turned on.
Charge LED	Charge LED remains lit until DC bus has fallen below approx. 50 V	
Environment	Area of Use	Indoors · chemical gas: IEC60721-3-3: 3 C2 · solid particle: IEC60721-3-3: 3 S2
	Power Supply	Overcurrent Category III
	Ambient Temperature	Open chassis type (IP20): -10°C to +50°C Enclosed wall-mounted type (UL Type 1): -10°C to +40°C · Do not use the drive in a location where the temperature changes suddenly to improve the drive reliability. · When installing the drive in an enclosure, use a cooling fan or air conditioner to keep the internal air temperature in the permitted range. · Do not let the drive freeze. · Derate the output current and output voltage to install the drive in areas with ambient temperatures ≤ 60 °C.
	Humidity	95% RH or less (no condensation)
	Storage Temperature	Short-term temperature during transportation is -20° C to +70° C
	Surrounding Area	Pollution degree 2 or less Install the drive in an area without: · Oil mist, corrosive or flammable gas, or dust · Metal powder, oil, water, or other unwanted materials · Radioactive materials or flammable materials, including wood · Harmful gas or fluids · Salt · Direct sunlight Keep wood or other flammable materials away from the drive.
	Altitude	1000 m or less Note: Altitudes over 1000 m and up to 3000 m are possible by derating the output current by 1% for every 100 m. Rated voltage derating is not required if the altitude of the area where the drive is installed is less than 2000 m. If the altitude of the area is 2000 m to 3000 m, neutral grounding of the power supply voltage is not required. If no neutral grounding is done, contact Yaskawa or your nearest sales representative.
	Shock	· 10 Hz to 20 Hz, 1 G (9.8 m/s <sup>2</sup> ) Note: 0.2 G for AG70X4930/AG70X4H12 · 20 Hz to 55 Hz, Catalog code GA70□2004 to 2211, 4002 to 4168: 0.6 G (5.9 m/s <sup>2</sup> ), Catalog code GA70□2257 to 2415, 4208 to 4675: 0.2 G (2.0 m/s <sup>2</sup> )
Standards Compliance	· UL61800-5-1*1 · EN61800-3:2004+A1:2012*1 · IEC/EN61800-5-1*1 · Two Safe Disable inputs and 1EDM output according to ISO/EN13849-1 Cat.3 Ple. IEC/EN61508 SIL3*1 Note: Used by setting functions to multi-function digital output terminals. · RCM*2 · EAC*2 · CSA*2 [Vessel Standards] · Germanischer Lloyd*2 · DNV*2 · ABS*2 · NK*2 · BV*2 · CCS*2 · KR*2	
Protection Design	Open chassis type (IP20), Enclosure wall-mounted type (UL Type 1) Note: Installing the UL Type 1 kit to a drive in an open chassis type (IP20) makes the drive compliant with an enclosure wall-mounted type (UL Type 1).	

\*1: Approval pending for catalog codes GA70□2169 to 2415, and GA70□4371 to 4675.

\*2: Approval pending.

Note: 1 Perform Rotational Auto-Tuning to achieve specifications listed for Open Loop Vector Control and Advanced Open Loop Vector Control.  
2 Install the drive in an environment matching the specifications in the table above for optimum performance life.

# Standard Connection Diagram

## Standard Connection Diagram

Multi-Function Photocoupler Output Type C (Standard)

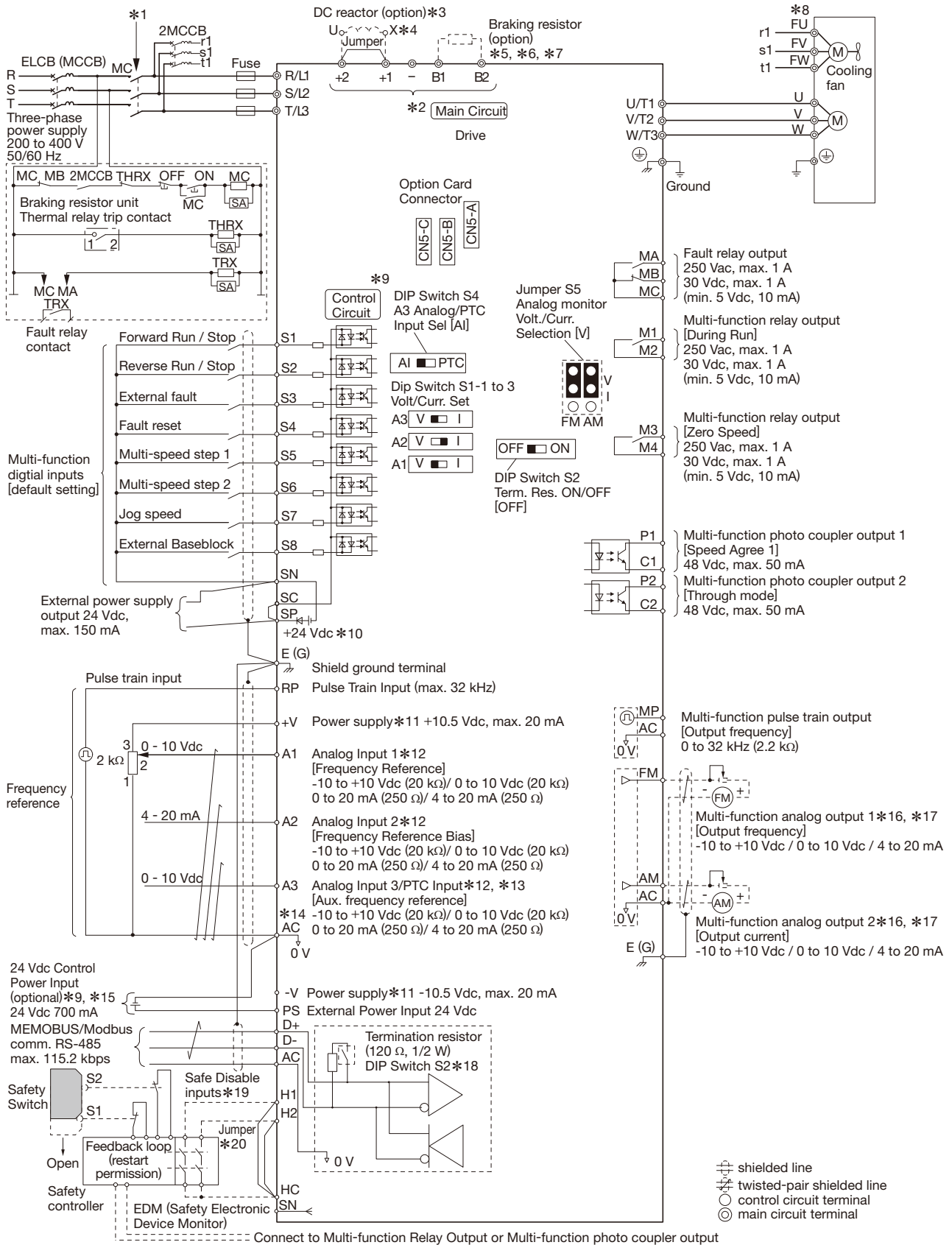



- \*1: We recommend that the sequence that de-energizes the power supply be set via the fault relay output for the drive. When using the Fault Restart function, if L5-02 = 1 [Fault Contact at Restart Select = Always Active], the fault signal is output during Restart Enabled and the power supply will turn OFF. Be careful when using a cut-off sequence. The default setting for L5-02 is 0 [Active Only when Not Restarting].
- \*2: Terminals -, +1, +2, B1 and B2 are the optional connection terminals. Do not connect an AC power supply to terminals -, +1, +2, B1, and B2. Failure to obey can cause damage to the drive and peripheral devices.
- \*3: Be sure to remove the jumper between terminals +1 and +2 when installing a DC reactor (option).
- \*4: Catalog codes GA70A2110 to 2415 and 4060 to 4675 have a built-in DC reactor.
- \*5: Be sure to set L8-55 = 0 [Internal DB Transistor Protection = Disable] when using an optional regenerative converter, regenerative unit, or braking unit. Leaving L8-55 = 1 [Protection Enabled] can cause rF [Braking Resistor Fault].
- \*6: Set L3-04 = 0 [Stall Prevention during Decel = Disabled] when using a regenerative converter, regenerative unit, braking unit, braking resistor, or braking resistor unit. If left unchanged, it may not stop within the designated deceleration time.
- \*7: When using a braking resistor (ERF type), set L8-01 = 1 [3% ERF DB Resistor Protection = Enabled] and be sure to use a sequence that shuts the power off by using the fault relay output for the drive.
- \*8: Self-cooling motors do not require the wiring for the motors with cooling fans.
- \*9: Connect a 24 V power supply to terminals PS-AC to operate the control circuit while the main circuit power supply is OFF.
- \*10: Use a wire jumper between terminals SC and SP or SC and SN to set the MFDI power supply to SINK Mode, SOURCE Mode, or External power supply. Do not short circuit terminals SP and SN. Failure to obey will cause damage to the drive.
  - SINK Mode: Install a jumper between terminals SC and SP. Do not short circuit terminals SC and SN. Failure to obey will cause damage to the drive.
  - SOURCE Mode: Install a jumper between terminals SC and SN. Do not short circuit terminals SC and SP. Failure to obey will cause damage to the drive.
  - External power supply: No jumper necessary between terminals SC and SN or terminals SC and SP.
- \*11: The output current capacity of the +V and -V terminals on the control circuit is 20 mA. Do not install a jumper between terminals +V, -V, and AC. Failure to obey can cause damage to the drive.
- \*12: DIP switches S1-1 to S1-3 set terminals A1 to A3 for voltage or current input. The default setting for S1-1 and S1-3 is voltage input ("V" side). The default setting for S1-2 is current input ("I" side).
- \*13: DIP switch S4 sets terminal A3 for analog or PTC input. Set DIP switch S1-3 to the "V" side, and set H3-05 = 0 [Terminal A3 Signal Level Select = 0 to 10 V (Lower Limit at 0)] to set terminal A3 for PTC input with DIP switch S4.
- \*14: Do not ground the control circuit terminals AC or connect them to the drive. Failure to comply may cause malfunction or failure.
- \*15: Connect the 24 V line of the 24 V control power supply input to terminal PS, and the 0 V line to terminal AC. Do not connect reverse terminals PS and AC. Failure to obey will cause damage to the drive.
- \*16: Use multi-function analog monitor outputs with analog frequency meters, ammeters, voltmeters, and wattmeters. Do not use monitor outputs with feedback-type signal devices.
- \*17: Jumper switch S5 sets terminal FM and AM for voltage or current output. The default setting is voltage output ("V" side).
- \*18: Set DIP switch S2 to "ON" to enable the termination resistor in the last drive in a MEMOBUS/Modbus network.
- \*19: Use only sourcing mode for Safe Disable input.
- \*20: Disconnect the wire jumper between H1 and HC, and H2 and HC to use the Safe Disable input.

# Standard Connection Diagram

## Standard Connection Diagram Multi-Function Digital Output Type A (Factory Option)

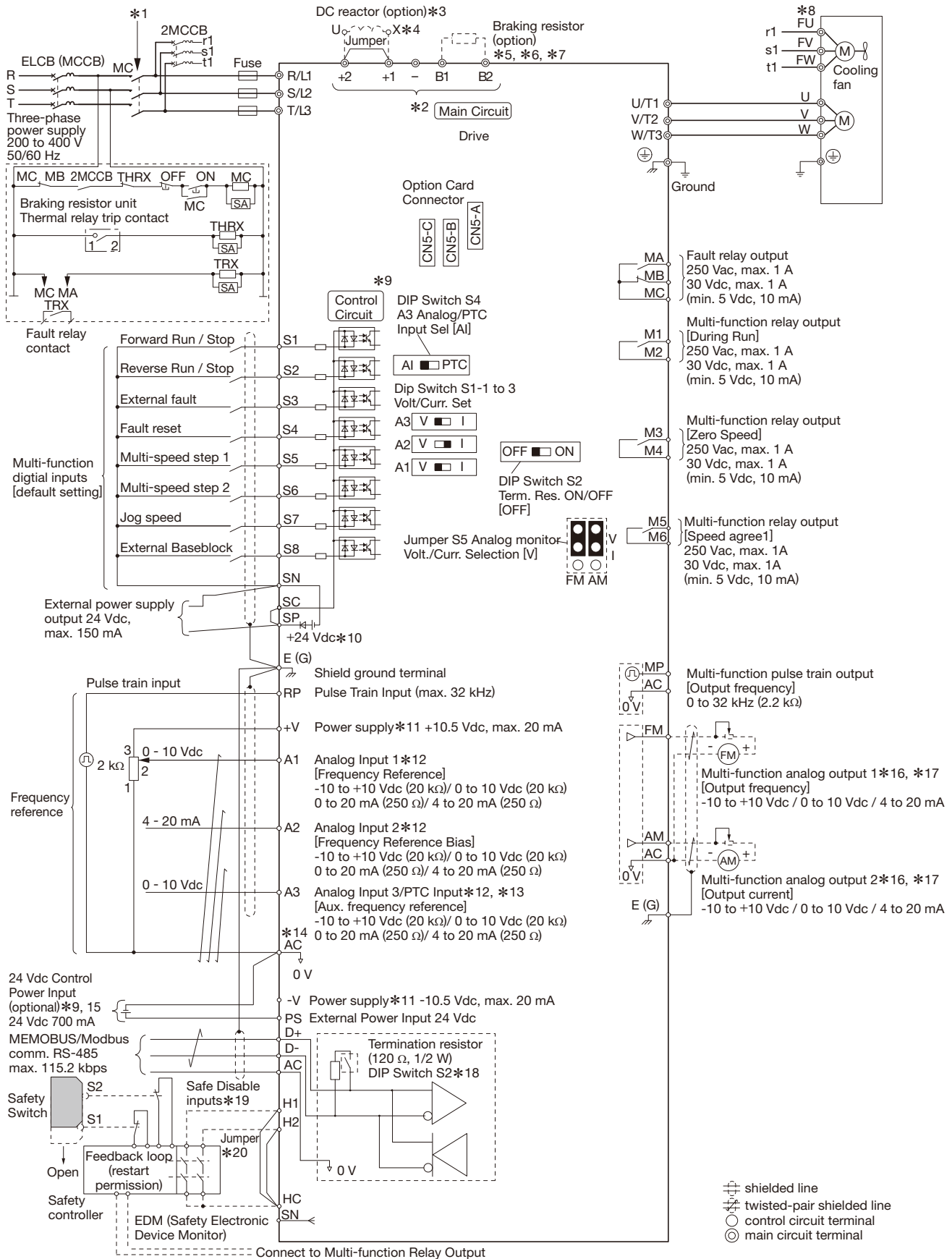

- \*1: We recommend that the sequence that de-energizes the power supply be set via the fault relay output for the drive. When using the Fault Restart function, if L5-02 = 1 [Fault Contact at Restart Select = Always Active], the fault signal is output during Restart Enabled and the power supply will turn OFF. Be careful when using a cut-off sequence. The default setting for L5-02 is 0 [Active Only when Not Restarting].
- \*2: Terminals -, +1, +2, B1 and B2 are the optional connection terminals. Do not connect an AC power supply to terminals -, +1, +2, B1, and B2. Failure to obey can cause damage to the drive and peripheral devices.
- \*3: Be sure to remove the jumper between terminals +1 and +2 when installing a DC reactor (option).
- \*4: Catalog codes GA70A2110 to 2415 and 4060 to 4675 have a built-in DC reactor.
- \*5: Be sure to set L8-55 = 0 [Internal DB Transistor Protection = Disable] when using an optional regenerative converter, regenerative unit, or braking unit. Leaving L8-55 = 1 [Protection Enabled] can cause rF [Braking Resistor Fault].
- \*6: Set L3-04 = 0 [Stall Prevention during Decel = Disabled] when using a regenerative converter, regenerative unit, braking unit, braking resistor, or braking resistor unit. If left unchanged, it may not stop within the designated deceleration time.
- \*7: When using a braking resistor (ERF type), set L8-01 = 1 [3% ERF DB Resistor Protection = Enabled] and be sure to use a sequence that shuts the power off by using the fault relay output for the drive.
- \*8: Self-cooling motors do not require the wiring for the motors with cooling fans.
- \*9: Connect a 24 V power supply to terminals PS-AC to operate the control circuit while the main circuit power supply is OFF.
- \*10: Use a wire jumper between terminals SC and SP or SC and SN to set the MFDI power supply to SINK Mode, SOURCE Mode, or External power supply. Do not short circuit terminals SP and SN. Failure to obey will cause damage to the drive.
  - SINK Mode: Install a jumper between terminals SC and SP. Do not short circuit terminals SC and SN. Failure to obey will cause damage to the drive.
  - SOURCE Mode: Install a jumper between terminals SC and SN. Do not short circuit terminals SC and SP. Failure to obey will cause damage to the drive.
  - External power supply: No jumper necessary between terminals SC and SN or terminals SC and SP.
- \*11: The output current capacity of the +V and -V terminals on the control circuit is 20 mA. Do not install a jumper between terminals +V, -V, and AC. Failure to obey can cause damage to the drive.
- \*12: DIP switches S1-1 to S1-3 set terminals A1 to A3 for voltage or current input. The default setting for S1-1 and S1-3 is voltage input ("V" side). The default setting for S1-2 is current input ("I" side).
- \*13: DIP switch S4 sets terminal A3 for analog or PTC input. Set DIP switch S1-3 to the "V" side, and set H3-05 = 0 [Terminal A3 Signal Level Select = 0 to 10 V (Lower Limit at 0)] to set terminal A3 for PTC input with DIP switch S4.
- \*14: Do not ground the control circuit terminals AC or connect them to the drive. Failure to comply may cause malfunction or failure.
- \*15: Connect the 24 V line of the 24 V control power supply input to terminal PS, and the 0 V line to terminal AC. Do not connect reverse terminals PS and AC. Failure to obey will cause damage to the drive.
- \*16: Use multi-function analog monitor outputs with analog frequency meters, ammeters, voltmeters, and wattmeters. Do not use monitor outputs with feedback-type signal devices.
- \*17: Jumper switch S5 sets terminal FM and AM for voltage or current output. The default setting is voltage output ("V" side).
- \*18: Set DIP switch S2 to "ON" to enable the termination resistor in the last drive in a MEMOBUS/Modbus network.
- \*19: Use only sourcing mode for Safe Disable input.
- \*20: Disconnect the wire jumper between H1 and HC, and H2 and HC to use the Safe Disable input.

# Terminal Specifications

## Terminal Functions

### Main Circuit Terminals

Max. Applicable Motor Capacity indicates Heavy Duty

Voltage	200 V Class			400 V Class			
Catalog Code GA70A	2004 to 2082	2110 to 2138	2169 to 2415	4002 to 4044	4060 to 4168	4208 to 4389	4453 to 4675
Max. Applicable Motor Capacity	0.4 to 18.5	22. 30	37 to 110	0.4 to 18.5	22 to 75	90 to 220	260 to 355
R/L1, S/L2, T/L3	Main circuit input power supply			Main circuit input power supply			
R1/L11, S1/L21, T1/L31	-			-			
U/T1, V/T2, W/T3	Drive output			Drive output			
B1, B2	Braking resistor unit		-	Braking resistor unit		-	
+2	DC reactor (+1,+2) DC power supply (+1,-)	-	DC power supply (+1,-) Braking unit (+3,-)	DC reactor (+1, +2) DC power supply (+1,-)	DC power supply (+1,-)	-	
+1		DC power supply (+1,-)				DC power supply (+1,-)	DC power supply (+1,-)
-	-		-	-		DC power supply (+1,-) Braking unit (+3,-)	
+3	-		-	-		-	
⊕	Ground terminal (100 Ω or less)			Ground terminal (10 Ω or less)			

Note: Use terminals B1 and - to connect a CDBR braking unit to drive models 2004 to 2138 and 4002 to 4168 with built-in braking transistors.

### Control Circuit Input Terminals (200 V/400 V Class)

Terminal Type	Terminal	Signal Function (default)	Description (Signal Level)	
Multi-Function Digital Input	S1	Multi-function input selection 1 (ON: Forward run OFF: Stop)	<ul style="list-style-type: none"> <li>• Photocoupler</li> <li>• 24 V, 6 mA</li> </ul> <p>Note: Use a wire jumper between terminals SC and SP or SC and SN to set the MFDI power supply to SINK Mode, SOURCE Mode, or External power supply.</p> <ul style="list-style-type: none"> <li>• SINK Mode: Install a jumper between terminals SC and SP. Do not short circuit terminals SC and SN. Failure to obey will cause damage to the drive.</li> <li>• SOURCE Mode: Install a jumper between terminals SC and SN. Do not short circuit terminals SC and SP. Failure to obey will cause damage to the drive.</li> <li>• External power supply: No jumper necessary between terminals SC and SN or terminals SC and SP.</li> </ul>	
	S2	Multi-function input selection 2 (ON: Reverse run OFF: Stop)		
	S3	Multi-function input selection 3 (External fault, N.O.)		
	S4	Multi-function input selection 4 (Fault reset)		
	S5	Multi-function input selection 5 (Multi-step speed reference 1)		
	S6	Multi-function input selection 6 (Multi-step speed reference 2)		
	S7	Multi-function input selection 7 (Jog frequency)		
	S8	Multi-function input selection 8 (Baseblock(N.O.))		
	SN	Digital input power supply 0V 24V transducer power supply 0V		Multi-function digital input power supply 24 V, maximum 150 mA
	SC	Multi-functions input common		Note: Do not install a jumper between terminals SP and SN. Failure to comply will damage the drive.
Safety Input	H1	Safety Input1	Remove the jumper between terminals H1-HC and H2-HC when using the Safe Disable input. <ul style="list-style-type: none"> <li>• 24 Vdc 6 mA</li> <li>• ON: Normal operation</li> <li>• OFF: Output disabled</li> <li>• Internal impedance 4.7 kΩ</li> <li>• Switching time at least 2 ms</li> </ul>	
	H2	Safety Input2		
	HC	Safety input common		Safety input common Note: Do not install a jumper between terminals HC and SN. Failure to comply will damage the drive.
Main Frequency Reference Input	RP	Multi-function pulse train input (Main frequency reference)	<ul style="list-style-type: none"> <li>• Scaling: 0.1 Hz to 32 kHz</li> <li>• H duty: 30% to 70%</li> <li>• H level voltage: 3.5 V to 13.2 V</li> <li>• L level voltage: 0.0 V to 0.8 V</li> <li>• impedance: 3 kΩ</li> </ul>	
	+V	Setting power supply	10.5 V (20 mA max.)	
	-V	Setting power supply	-10.5 V (20 mA max.)	
	A1	Multi-function analog input 1 (Main frequency reference)	Voltage input or current input DIP switch S1-1 and H3-01 can be used to set the voltage or current output for terminal A1 (Terminal A1 Signal Level Select.) DIP switch S1-2 and H3-09 can be used to set the voltage or current output for terminal A2 (Terminal A2 Signal Level Select.)	
	A2	Multi-function analog input 2 (Frequency reference bias with terminal A1)	<ul style="list-style-type: none"> <li>• -10 to +10 Vdc for -100 to +100% (impedance 20 kΩ)</li> <li>• 0 to 10 Vdc for 0 to 100% (impedance 20 kΩ)</li> <li>• 4 to 20 mA for 0 to 100%, 0 to 20 mA for 0 to 100% (impedance 250 Ω)</li> </ul>	
	A3	Multi-function analog input 3/PTC input (Auxiliary frequency reference)	Voltage input or current input Selected with dip switches S1-3 and H3-05 (Terminal A3 Signal Level Select.) <ul style="list-style-type: none"> <li>• -10 to +10 Vdc for -100 to +100% (impedance 20 kΩ)</li> <li>• 0 to 10 Vdc for 0 to 100% (impedance 20 kΩ)</li> <li>• 4 to 20 mA for 0 to 100%, 0 to 20 mA for 0 to 100% (impedance 250 Ω)</li> </ul> PTC input (For motor overheat protection) Set DIP switch S4 to "PTC" and set DIP switch S1-3 to "V" to set terminal A3 for PTC input.	
	AC	Frequency reference common	0 V	
Fault Relay Output	E (G)	Connection to wire shielding and option card ground wire	-	
	MA	N.O. output (Fault)	<ul style="list-style-type: none"> <li>• Relay output</li> <li>• 30 Vdc or less, 10 mA to 1 A</li> <li>• 250 Vac or less, 10 mA to 1 A</li> <li>• Minimum load: 5 Vdc, 10 mA (Values only for reference)</li> </ul>	
	MB	N.C. output (Fault)		
MC	Digital output common			

### Control Circuit Input Terminals (200 V/400 V Class) (continued)

Terminal Type	Terminal	Signal Function (default)	Description (Signal Level)
Multi-Function Digital Output	M1	Multi-function digital output (During run)	<ul style="list-style-type: none"> <li>Relay output</li> <li>30 Vdc or less, 10 mA to 1 A</li> <li>250 Vac or less, 10 mA to 1 A</li> <li>Minimum load: 5 Vdc, 10 mA (Values only for reference)</li> </ul> Note: Refrain from assigning functions to terminals M1 and M2, M3 and M4, and M4 and M5 that involve frequent switching, as doing so may shorten relay performance life. Switching life is estimated at 200,000 times (assumes 1 A, resistive load).
	M2		
	M3	Multi-function digital output (zero speed)	
	M4	Multi-function digital output (zero speed)	
	M5*1 M6*1	Multi-function digital output (Speed agree1)	
Multi-Function Photocoupler Output*2	P1	Multi-Function Photocoupler Output (Speed agree1)	<ul style="list-style-type: none"> <li>Photocoupler output</li> <li>48 Vdc or less, 2 to 50 mA</li> </ul> Note: Connect a flywheel diode as shown below when driving a reactive load such as a relay coil. Diode must be rated higher than the circuit voltage.
	C1	Multi-Function Photocoupler Output (Through mode)	
	P2 C2	Multi-Function Photocoupler Output (Through mode)	
Monitor Output	MP	Pulse train input (Output frequency)	Max. 32 kHz
	FM	analog monitor (1) (Output frequency)	Voltage or current output · 0 to 10 Vdc for 0 to 100% · -10 to 10 Vdc for -100 to 100% · 4 to 20 mA
	AM	analog monitor (2) (Output current)	Note: Set jumper S5, and H4-07 (Terminal FM Signal Level Select.) and H4-08 (Terminal AM Signal Level Select.) to select the signal type for terminals AM and FM.
	AC	Monitor common	0 V

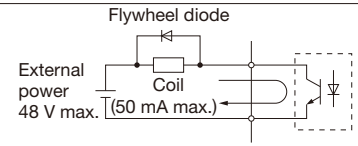

\*1: Multi-function digital output type A is compatible.  
 \*2: Multi-function photocoupler output type C (standard) is compatible.

### External Power Supply Input Terminals (200 V/400 V Class)

Type	Terminal	Terminal Name (Default)	Function
External power supply input terminals	PS	External 24 V power supply input	Supplies backup power to the drive control circuit, keypad, and option card. 21.6 Vdc to 26.4 Vdc, 700 mA
	AC	External 24 V power supply ground	0 V

### Serial Communication Terminals (200 V/400 V Class)

Classification	Terminal	Signal Function	Description (Signal Level)
MEMOBUS / Modbus communications	D+	Communications input (+)	MEMOBUS/Modbus communications: Use a RS-485 cable to connect the drive. Note: Set DIP switch S2 to ON to enable the termination resistor in the last drive in a MEMOBUS/Modbus network.
	D-	Communications input (-)	
	AC	Shield ground	0 V

## ● Screw Terminal

The screw terminal type for the main circuit terminal (factory option) is being prepared.

## ● Tools for Wiring European Style Terminal Blocks (Recommended product)

Check the "Terminal size / Wire gauge" on the next page and prepare the tools for wiring.

Screw size	Screw type	Recommended Product	Screw size	Screw type	Recommended Product									
M4	Slot	Prepare the following two tools. · Bit [PHOENIX CONTACT] Model: SF-BIT-SL 1,0X4,0-70 · Torque screwdriver [PHOENIX CONTACT] Model: TSD-M 3NM (1.2 to 3 N·m)	M10	Hex socket (WAF: 8)	Prepare the following three tools. · Bit [PHOENIX CONTACT] Model: SF-BIT-HEX 8-50 · Torque wrench that includes a torque measurement range of 14 N·m · Bit socket holder of 6.35 mm									
M5	Slot	When wiring drive models GA70□2056 and GA70□4089 or earlier models, be sure to correctly select tools based on the wire gauges. Wiring Gauge: ≤25 mm <sup>2</sup> or AWG10 · Bit [PHOENIX CONTACT] Model: SF-BIT-SL 1,2X6,5-70 · Torque screwdriver [PHOENIX CONTACT] Model: TSD-M 3NM (1.2 to 3 N·m) Wiring Gauge: ≥30 mm <sup>2</sup> or AWG8 · Torque wrench that includes a torque measurement range of 4.5 N·m · Bit socket holder of 6.35 mm			<table border="1"> <thead> <tr> <th>Bit</th> <th>Torque screwdriver</th> <th>Torque wrench</th> </tr> </thead> <tbody> <tr> <td>Application screw slot </td> <td></td> <td></td> </tr> </tbody> </table>	Bit	Torque screwdriver	Torque wrench	Application screw slot 					
Bit	Torque screwdriver	Torque wrench												
Application screw slot 														
M6	Hex socket (WAF: 5)	Prepare the following three tools. · Bit [PHOENIX CONTACT] Model: SF-BIT-HEX 5-50 · Torque wrench that includes a torque measurement range of 9 N·m · Bit socket holder of 6.35 mm												
	Minus	Prepare the following three tools for the models GA70□2110 to 2138, and GA70□4103. · Bit [PHOENIX CONTACT] Model: SF-BIT-SL 1,2X6,5-70 · Torque wrench that includes a torque measurement range of 3.5 N·m · Bit socket holder of 6.35 mm												
M8	Hex socket (WAF: 6)	Prepare the following three tools. · Bit [PHOENIX CONTACT] Model: SF-BIT-HEX 6-50 · Torque wrench that includes a torque measurement range of 12 N·m · Bit socket holder of 6.35 mm	<table border="1"> <thead> <tr> <th colspan="3">Bit socket holder</th> </tr> </thead> <tbody> <tr> <td colspan="3"> </td> </tr> <tr> <td>S: 6.35 mm</td> <td></td> <td>sq</td> </tr> </tbody> </table>			Bit socket holder						S: 6.35 mm		sq
Bit socket holder														
S: 6.35 mm		sq												

# Terminal Specifications

## Terminal Size / Wire Gauge

### 200 V Class

Catalog code GA70A□	Terminal	Recommended Gauge mm <sup>2</sup>	Wire Range (IP20 Compatible Gauge) mm <sup>2</sup>	Wire Stripping Length* <sup>1</sup> mm	Terminal Screw		Tightening Torque N · m	Catalog code GA70A□	Terminal	Recommended Gauge mm <sup>2</sup>	Wire Range (IP20 Compatible Gauge) mm <sup>2</sup>	Wire Stripping Length* <sup>1</sup> mm	Terminal Screw		Tightening Torque N · m
					Size	Shape							Size	Shape	
2004	R/L1, S/L2, T/L3	2	2 to 14 (2 to 14)	10	M4	Slot (-)	1.5 to 1.7	2056	R/L1, S/L2, T/L3	22	2 to 22 (8 to 22)	18	M5	Slot (-)	2.3 to 2.5* <sup>2</sup>
	U/T1, V/T2, W/T3	2	2 to 14 (2 to 14)	10	M4	Slot (-)	1.5 to 1.7		U/T1, V/T2, W/T3	14	2 to 14 (5.5 to 14)	18	M5	Slot (-)	2.3 to 2.5* <sup>2</sup>
	-, +1, +2	2	2 to 22 (2 to 22)	18	M5	Slot (-)	2.3 to 2.5* <sup>2</sup>		-, +1, +2	38	2 to 38 (8 to 38)	20	M6	Hex socket (WAF: 5)	5 to 5.5
	B1, B2	2	2 to 5.5 (2 to 5.5)	10	M4	Slot (-)	1.5 to 1.7		B1, B2	14	2 to 14 (2 to 14)	10	M4	Slot (-)	1.5 to 1.7
2006	R/L1, S/L2, T/L3	2	2 to 14 (2 to 14)	10	M4	Slot (-)	1.5 to 1.7	2070	R/L1, S/L2, T/L3	38	2 to 38 (22 to 38)	20	M6	Hex socket (WAF: 5)	5 to 5.5
	U/T1, V/T2, W/T3	2	2 to 14 (2 to 14)	10	M4	Slot (-)	1.5 to 1.7		U/T1, V/T2, W/T3	22	2 to 22 (14 to 22)	20	M6	Hex socket (WAF: 5)	5 to 5.5
	-, +1, +2	2	2 to 22 (2 to 22)	18	M5	Slot (-)	2.3 to 2.5* <sup>2</sup>		-, +1, +2	50	2 to 50 (22 to 50)	20	M6	Hex socket (WAF: 5)	5 to 5.5
	B1, B2	2	2 to 5.5 (2 to 5.5)	10	M4	Slot (-)	1.5 to 1.7		B1, B2	14	2 to 14 (2 to 14)	10	M4	Slot (-)	1.5 to 1.7
2008	R/L1, S/L2, T/L3	2	2 to 14 (2 to 14)	10	M4	Slot (-)	1.5 to 1.7	2082	R/L1, S/L2, T/L3	50	2 to 50 (22 to 50)	20	M6	Hex socket (WAF: 5)	5 to 5.5
	U/T1, V/T2, W/T3	2	2 to 14 (2 to 14)	10	M4	Slot (-)	1.5 to 1.7		U/T1, V/T2, W/T3	30	2 to 30 (14 to 30)	20	M6	Hex socket (WAF: 5)	5 to 5.5
	-, +1, +2	2	2 to 22 (2 to 22)	18	M5	Slot (-)	2.3 to 2.5* <sup>2</sup>		-, +1, +2	60	2 to 60 (22 to 60)	20	M6	Hex socket (WAF: 5)	5 to 5.5
	B1, B2	2	2 to 5.5 (2 to 5.5)	10	M4	Slot (-)	1.5 to 1.7		B1, B2	14	2 to 14 (2 to 14)	10	M4	Slot (-)	1.5 to 1.7
2010	R/L1, S/L2, T/L3	2	2 to 14 (2 to 14)	10	M4	Slot (-)	1.5 to 1.7	2110	R/L1, S/L2, T/L3	38	22 to 38 (22 to 38)	27	M6	Hex socket (WAF: 5)	8 to 9
	U/T1, V/T2, W/T3	2	2 to 14 (2 to 14)	10	M4	Slot (-)	1.5 to 1.7		U/T1, V/T2, W/T3	38	22 to 38 (22 to 38)	27	M6	Hex socket (WAF: 5)	8 to 9
	-, +1, +2	2	2 to 22 (2 to 22)	18	M5	Slot (-)	2.3 to 2.5* <sup>2</sup>		-, +1	60	30 to 60 (30 to 60)	27	M8	Hex socket (WAF: 6)	10 to 12
	B1, B2	2	2 to 5.5 (2 to 5.5)	10	M4	Slot (-)	1.5 to 1.7		B1, B2	22	8 to 22 (8 to 22)	21	M6	Minus (-)	3 to 3.5
2012	R/L1, S/L2, T/L3	3.5	2 to 14 (2 to 14)	10	M4	Slot (-)	1.5 to 1.7	2138	R/L1, S/L2, T/L3	60	22 to 60 (38 to 60)	27	M6	Hex socket (WAF: 5)	8 to 9
	U/T1, V/T2, W/T3	2	2 to 14 (2 to 14)	10	M4	Slot (-)	1.5 to 1.7		U/T1, V/T2, W/T3	60	22 to 60 (38 to 60)	27	M6	Hex socket (WAF: 5)	8 to 9
	-, +1, +2	3.5	2 to 22 (2 to 22)	18	M5	Slot (-)	2.3 to 2.5* <sup>2</sup>		-, +1	80	30 to 80 (50 to 80)	27	M8	Hex socket (WAF: 6)	10 to 12
	B1, B2	2	2 to 5.5 (2 to 5.5)	10	M4	Slot (-)	1.5 to 1.7		B1, B2	30	8 to 30 (8 to 30)	21	M6	Minus (-)	3 to 3.5
2018	R/L1, S/L2, T/L3	3.5	2 to 14 (2 to 14)	10	M4	Slot (-)	1.5 to 1.7	2169	R/L1, S/L2, T/L3	80	50 to 100 (80 to 100)	37	M10	Hex socket (WAF: 8)	12 to 14
	U/T1, V/T2, W/T3	3.5	2 to 14 (2 to 14)	10	M4	Slot (-)	1.5 to 1.7		U/T1, V/T2, W/T3	80	50 to 125 (80 to 125)	37	M10	Hex socket (WAF: 8)	12 to 14
	-, +1, +2	5.5	2 to 22 (2 to 22)	18	M5	Slot (-)	2.3 to 2.5* <sup>2</sup>		-, -, +1, +1* <sup>3</sup>	38* <sup>4</sup>	22 to 50 (50)	28	M6	Hex socket (WAF: 5)	8 to 9
	B1, B2	2	2 to 5.5 (2 to 5.5)	10	M4	Slot (-)	1.5 to 1.7		+3	60	30 to 80* <sup>5</sup> (50 to 80)* <sup>5</sup>	28	M8	Hex socket (WAF: 6)	8 to 9
2021	R/L1, S/L2, T/L3	8	2 to 14 (2 to 14)	10	M4	Slot (-)	1.5 to 1.7	2211	R/L1, S/L2, T/L3	100	50 to 100 (80 to 100)	37	M10	Hex socket (WAF: 8)	12 to 14
	U/T1, V/T2, W/T3	3.5	2 to 14 (2 to 14)	10	M4	Slot (-)	1.5 to 1.7		U/T1, V/T2, W/T3	125	50 to 125 (80 to 125)	37	M10	Hex socket (WAF: 8)	12 to 14
	-, +1, +2	8	2 to 22 (2 to 22)	18	M5	Slot (-)	2.3 to 2.5* <sup>2</sup>		-, -, +1, +1* <sup>3</sup>	50	22 to 50 (50)	28	M6	Hex socket (WAF: 5)	8 to 9
	B1, B2	2	2 to 5.5 (2 to 5.5)	10	M4	Slot (-)	1.5 to 1.7		+3	80	30 to 80* <sup>5</sup> (50 to 80)* <sup>5</sup>	28	M8	Hex socket (WAF: 6)	8 to 9
2030	R/L1, S/L2, T/L3	14	2 to 14 (2 to 14)	10	M4	Slot (-)	1.5 to 1.7	2030	R/L1, S/L2, T/L3	14	2 to 14 (2 to 14)	10	M4	Slot (-)	1.5 to 1.7
	U/T1, V/T2, W/T3	8	2 to 14 (2 to 14)	10	M4	Slot (-)	1.5 to 1.7		U/T1, V/T2, W/T3	8	2 to 14 (2 to 14)	10	M4	Slot (-)	1.5 to 1.7
	-, +1, +2	14	2 to 22 (2 to 22)	18	M5	Slot (-)	2.3 to 2.5* <sup>2</sup>		-, +1, +2	14	2 to 22 (2 to 22)	18	M5	Slot (-)	2.3 to 2.5* <sup>2</sup>
	B1, B2	3.5	2 to 5.5 (2 to 5.5)	10	M4	Slot (-)	1.5 to 1.7		B1, B2	3.5	2 to 5.5 (2 to 5.5)	10	M4	Slot (-)	1.5 to 1.7
2042	R/L1, S/L2, T/L3	14	2 to 14 (2 to 14)	10	M4	Slot (-)	1.5 to 1.7	2042	R/L1, S/L2, T/L3	14	2 to 14 (2 to 14)	10	M4	Slot (-)	1.5 to 1.7
	U/T1, V/T2, W/T3	14	2 to 14 (2 to 14)	10	M4	Slot (-)	1.5 to 1.7		U/T1, V/T2, W/T3	14	2 to 14 (2 to 14)	10	M4	Slot (-)	1.5 to 1.7
	-, +1, +2	22	2 to 22 (2 to 22)	18	M5	Slot (-)	2.3 to 2.5* <sup>2</sup>		-, +1, +2	22	2 to 22 (2 to 22)	18	M5	Slot (-)	2.3 to 2.5* <sup>2</sup>
	B1, B2	5.5	2 to 5.5 (2 to 5.5)	10	M4	Slot (-)	1.5 to 1.7		B1, B2	5.5	2 to 5.5 (2 to 5.5)	10	M4	Slot (-)	1.5 to 1.7

\*1: Remove the insulator from the tips of wires to the length shown in "Wire Stripping Length."  
 \*2: When using wire with a gauge over 30 mm<sup>2</sup>, tighten to a tightening torque of 4.1 to 4.5 N·m.  
 \*3: Terminals - and +1 have two screws. Recommended Gauge means the wire gauge of one terminal.  
 \*4: Use cables in the range of applicable gauges to meet the IP20 protective level.  
 \*5: A junction terminal is required when connecting a braking unit (CDBR series) or a braking resistor unit (LKEB series).  
 Note: The recommended wire gauges based on drive continuous current ratings using 75°C 600 V class 2 heat resistant indoor PVC wire.  
 Assume the following usage conditions:  
 · Ambient temperature: 40°C or lower  
 · Wiring distance: 100 m or shorter  
 · Normal Duty rated current value

## 400 V Class

Catalog code GA70A□	Terminal	Recommended Gauge mm <sup>2</sup>	Wire Range (IP20 Compatible Gauge) mm <sup>2</sup>	Wire Stripping Length*1 mm	Terminal Screw		Tightening Torque N · m	Catalog code GA70A□	Terminal	Recommended Gauge mm <sup>2</sup>	Wire Range (IP20 Compatible Gauge) mm <sup>2</sup>	Wire Stripping Length*1 mm	Terminal Screw		Tightening Torque N · m
					Size	Shape							Size	Shape	
4002	R/L1, S/L2, T/L3	2	2 to 14 (2 to 14)	10	M4	Slot (-)	1.5 to 1.7	4038	R/L1, S/L2, T/L3	14	2 to 22 (8 to 22)	18	M5	Slot (-)	2.3 to 2.5*2
	U/T1, V/T2, W/T3	2	2 to 14 (2 to 14)	10	M4	Slot (-)	1.5 to 1.7		U/T1, V/T2, W/T3	14	2 to 14 (5.5 to 14)	18	M5	Slot (-)	2.3 to 2.5*2
	- , +1, +2	2	2 to 22 (2 to 22)	18	M5	Slot (-)	2.3 to 2.5*2		- , +1, +2	22	2 to 38 (8 to 38)	20	M6	Hex socket (WAF: 5)	5 to 5.5
	B1, B2	2	2 to 5.5 (2 to 5.5)	10	M4	Slot (-)	1.5 to 1.7		B1, B2	5.5	2 to 14 (2 to 14)	10	M4	Slot (-)	1.5 to 1.7
4004	R/L1, S/L2, T/L3	2	2 to 14 (2 to 14)	10	M4	Slot (-)	1.5 to 1.7	4044	R/L1, S/L2, T/L3	14	2 to 14 (3.5 to 14)	18	M5	Slot (-)	2.3 to 2.5*2
	U/T1, V/T2, W/T3	2	2 to 14 (2 to 14)	10	M4	Slot (-)	1.5 to 1.7		U/T1, V/T2, W/T3	14	2 to 14 (5.5 to 14)	18	M5	Slot (-)	2.3 to 2.5*2
	- , +1, +2	2	2 to 22 (2 to 22)	18	M5	Slot (-)	2.3 to 2.5*2		- , +1, +2	22	2 to 22 (3.5 to 22)	18	M5	Slot (-)	2.3 to 2.5*2
	B1, B2	2	2 to 5.5 (2 to 5.5)	10	M4	Slot (-)	1.5 to 1.7		B1, B2	8	2 to 8 (2 to 8)	10	M4	Slot (-)	1.5 to 1.7
4005	R/L1, S/L2, T/L3	2	2 to 14 (2 to 14)	10	M4	Slot (-)	1.5 to 1.7	4060	R/L1, S/L2, T/L3	14	2 to 14 (3.5 to 14)	18	M5	Slot (-)	2.3 to 2.5*2
	U/T1, V/T2, W/T3	2	2 to 14 (2 to 14)	10	M4	Slot (-)	1.5 to 1.7		U/T1, V/T2, W/T3	14	2 to 14 (5.5 to 14)	18	M5	Slot (-)	2.3 to 2.5*2
	- , +1, +2	2	2 to 22 (2 to 22)	18	M5	Slot (-)	2.3 to 2.5*2		- , +1	22	2 to 22 (3.5 to 22)	18	M5	Slot (-)	2.3 to 2.5*2
	B1, B2	2	2 to 5.5 (2 to 5.5)	10	M4	Slot (-)	1.5 to 1.7		B1, B2	14	2 to 14 (2 to 14)	10	M4	Slot (-)	1.5 to 1.7
4007	R/L1, S/L2, T/L3	2	2 to 14 (2 to 14)	10	M4	Slot (-)	1.5 to 1.7	4075	R/L1, S/L2, T/L3	22	2 to 22 (3.5 to 22)	18	M5	Slot (-)	2.3 to 2.5*2
	U/T1, V/T2, W/T3	2	2 to 14 (2 to 14)	10	M4	Slot (-)	1.5 to 1.7		U/T1, V/T2, W/T3	22	2 to 22 (3.5 to 22)	18	M5	Slot (-)	2.3 to 2.5*2
	- , +1, +2	2	2 to 22 (2 to 22)	18	M5	Slot (-)	2.3 to 2.5*2		- , +1	30	2 to 30 (3.5 to 30)	18	M5	Slot (-)	2.3 to 2.5*2
	B1, B2	2	2 to 5.5 (2 to 5.5)	10	M4	Slot (-)	1.5 to 1.7		B1, B2	14	2 to 14 (2 to 14)	10	M4	Slot (-)	1.5 to 1.7
4009	R/L1, S/L2, T/L3	2	2 to 14 (2 to 14)	10	M4	Slot (-)	1.5 to 1.7	4089	R/L1, S/L2, T/L3	30	2 to 30 (5.5 to 30)	18	M5	Slot (-)	2.3 to 2.5*2
	U/T1, V/T2, W/T3	2	2 to 14 (2 to 14)	10	M4	Slot (-)	1.5 to 1.7		U/T1, V/T2, W/T3	30	2 to 30 (5.5 to 30)	18	M5	Slot (-)	2.3 to 2.5*2
	- , +1, +2	2	2 to 22 (2 to 22)	18	M5	Slot (-)	2.3 to 2.5*2		- , +1	38	2 to 38 (22 to 38)	20	M6	Hex socket (WAF: 5)	5 to 5.5
	B1, B2	2	2 to 5.5 (2 to 5.5)	10	M4	Slot (-)	1.5 to 1.7		B1, B2	22	2 to 22 (3.5 to 22)	18	M5	Slot (-)	2.3 to 2.5*2
4012	R/L1, S/L2, T/L3	2	2 to 14 (2 to 14)	10	M4	Slot (-)	1.5 to 1.7	4103	R/L1, S/L2, T/L3	38	22 to 60 (38 to 60)	27	M6	Hex socket (WAF: 5)	8 to 9
	U/T1, V/T2, W/T3	2	2 to 14 (2 to 14)	10	M4	Slot (-)	1.5 to 1.7		U/T1, V/T2, W/T3	38	22 to 60 (38 to 60)	27	M6	Hex socket (WAF: 5)	8 to 9
	- , +1, +2	3.5	2 to 22 (2 to 22)	18	M5	Slot (-)	2.3 to 2.5*2		- , +1	50	30 to 80 (50 to 80)	27	M8	Hex socket (WAF: 6)	10 to 12
	B1, B2	2	2 to 5.5 (2 to 5.5)	10	M4	Slot (-)	1.5 to 1.7		B1, B2	30	8 to 30 (8 to 30)	21	M6	Minus (-)	3 to 3.5
4018	R/L1, S/L2, T/L3	3.5	2 to 14 (2 to 14)	10	M4	Slot (-)	1.5 to 1.7	4140	R/L1, S/L2, T/L3	60*4	50 to 100 (80 to 100)	37	M10	Hex socket (WAF: 8)	12 to 14
	U/T1, V/T2, W/T3	3.5	2 to 14 (2 to 14)	10	M4	Slot (-)	1.5 to 1.7		U/T1, V/T2, W/T3	60*4	50 to 125 (80 to 125)	37	M10	Hex socket (WAF: 8)	12 to 14
	- , +1, +2	5.5	2 to 22 (2 to 22)	18	M5	Slot (-)	2.3 to 2.5*2		- , - , +1, +1*3	30*4	22 to 50 (50)	28	M6	Hex socket (WAF: 5)	8 to 9
	B1, B2	2	2 to 5.5 (2 to 5.5)	10	M4	Slot (-)	1.5 to 1.7		B1, B2	50	30 to 80*5 (50 to 80) *5	28	M8	Hex socket (WAF: 6)	8 to 9
4023	R/L1, S/L2, T/L3	8	2 to 14 (2 to 14)	10	M4	Slot (-)	1.5 to 1.7	4168	R/L1, S/L2, T/L3	80	50 to 100 (80 to 100)	37	M10	Hex socket (WAF: 8)	12 to 14
	U/T1, V/T2, W/T3	5.5	2 to 14 (2 to 14)	10	M4	Slot (-)	1.5 to 1.7		U/T1, V/T2, W/T3	80	50 to 125 (80 to 125)	37	M10	Hex socket (WAF: 8)	12 to 14
	- , +1, +2	14	2 to 22 (2 to 22)	18	M5	Slot (-)	2.3 to 2.5*2		- , - , +1, +1*3	38*4	22 to 50 (50)	28	M6	Hex socket (WAF: 5)	8 to 9
	B1, B2	2	2 to 5.5 (2 to 5.5)	10	M4	Slot (-)	1.5 to 1.7		B1, B2	60	30 to 80*5 (50 to 80) *5	28	M8	Hex socket (WAF: 6)	8 to 9
4031	R/L1, S/L2, T/L3	14	2 to 22 (8 to 22)	18	M5	Slot (-)	2.3 to 2.5*2	*1: Remove the insulator from the tips of wires to the length shown in "Wire Stripping Length." *2: When using wire with a gauge over 30 mm <sup>2</sup> , tighten to a tightening torque of 4.1 to 4.5 N·m. *3: Terminals - and +1 have two screws. Recommended Gauge means the wire gauge of one terminal. *4: Use cables in the range of applicable gauges to meet the IP20 protective level. *5: A junction terminal is required when connecting a braking unit (CDBR series) or a braking resistor unit (LKEB series).	R/L1, S/L2, T/L3	14	2 to 22 (8 to 22)	18	M5	Slot (-)	2.3 to 2.5*2
	U/T1, V/T2, W/T3	8	2 to 14 (5.5 to 14)	18	M5	Slot (-)	2.3 to 2.5*2		U/T1, V/T2, W/T3	8	2 to 14 (5.5 to 14)	18	M5	Slot (-)	2.3 to 2.5*2
	- , +1, +2	14	2 to 38 (8 to 38)	20	M6	Hex socket (WAF: 5)	5 to 5.5		- , +1, +2	14	2 to 38 (8 to 38)	20	M6	Hex socket (WAF: 5)	5 to 5.5
	B1, B2	3.5	2 to 14 (2 to 14)	10	M4	Slot (-)	1.5 to 1.7		B1, B2	3.5	2 to 14 (2 to 14)	10	M4	Slot (-)	1.5 to 1.7

\*1: Remove the insulator from the tips of wires to the length shown in "Wire Stripping Length."  
\*2: When using wire with a gauge over 30 mm<sup>2</sup>, tighten to a tightening torque of 4.1 to 4.5 N·m.  
\*3: Terminals - and +1 have two screws. Recommended Gauge means the wire gauge of one terminal.  
\*4: Use cables in the range of applicable gauges to meet the IP20 protective level.  
\*5: A junction terminal is required when connecting a braking unit (CDBR series) or a braking resistor unit (LKEB series).

Note: The recommended wire gauges based on drive continuous current ratings using 75°C 600 V class 2 heat resistant indoor PVC wire.

Assume the following usage conditions:

- Ambient temperature: 40°C or lower
- Normal Duty rated current value
- Wiring distance: 100 m or shorter

# Dimensions

## Enclosures

### 200 V Class

HD: Heavy Duty, ND: Normal Duty

Catalog Code GA70A□		2004	2006	2008	2010	2012	2018	2021	2030	2042	2056	2070	2082	2110	2138	2169	2211	2257	2313	2360	2415
Max. Applicable Motor Capacity (kW)	HD	0.4	0.75	1.1	1.5	2.2	3	3.7	5.5	7.5	11	15	18.5	22	30	37	45	55	75	90	110
	ND	0.75	1.1	1.5	2.2	3	3.7	5.5	7.5	11	15	18.5	22	30	37	45	55	75	90	110	-
Open Chassis [IP20]	IP20 supported with standard model																				
Enclosure Wall-Mounted [UL Type1]	Option supported (Install UL Type 1 kit for IP20)																				*

### 400 V Class

HD: Heavy Duty, ND: Normal Duty

Catalog Code GA70A□		4002	4004	4005	4007	4009	4012	4018	4023	4031	4038	4044	4060	4075	4089	4103
Max. Applicable Motor Capacity (kW)	HD	0.4	0.75	1.5	2.2	3	3.7	5.5	7.5	11	15	18.5	22	30	37	45
	ND	0.75	1.5	2.2	3	3.7	5.5	7.5	11	15	18.5	22	30	37	45	55
Open Chassis [IP20]	IP20 supported with standard model															
Enclosure Wall-Mounted [UL Type1]	Option supported (Install UL Type 1 kit for IP20)															*

Catalog Code GA70A□		4140	4168	4208	4250	4296	4371	4389	4453	4568	4675
Max. Applicable Motor Capacity (kW)	HD	55	75	90	110	132	160	200	220	250	315
	ND	75	90	110	132	160	200	220	250	315	355
Open Chassis [IP20]	IP20 supported with standard model										
Enclosure Wall-Mounted [UL Type1]	Option supported (Install UL Type 1 kit for IP20)					*					

\* UL Type 1 is not available for this capacity.

### Open Chassis [IP20]

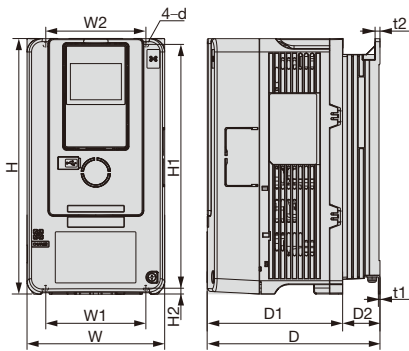

Figure 1

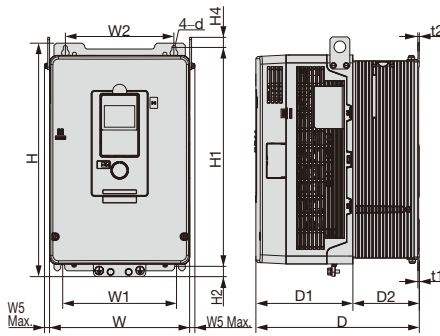

Figure 2

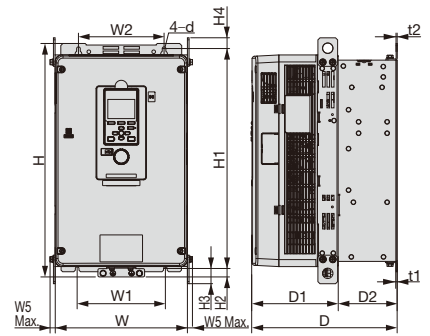

Figure 3

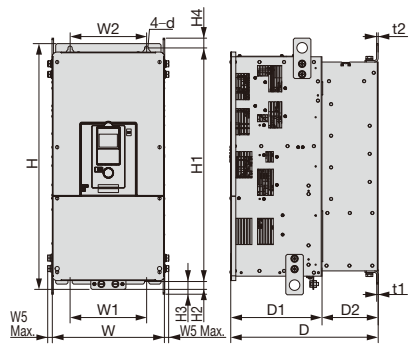

Figure 4

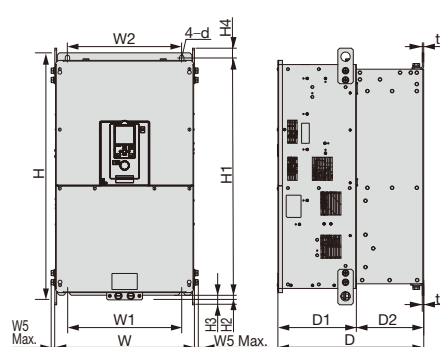

Figure 5

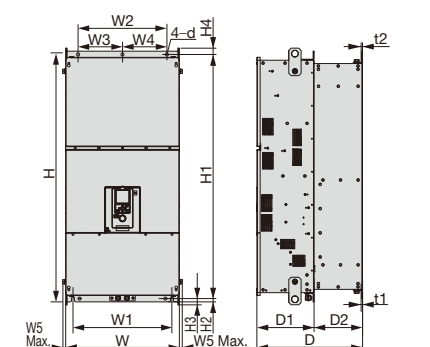

Figure 6



## 200 V Class

Catalog Code GA70A	Figure	Dimensions mm														Weight kg			
		W	H	D	D1	D2	W1	W2	W3	W4	W5	H1	H2	H3	H4		t1	t2	d
2004	1	140	260	176	138	38	102	102	-	-	-	248	6	-	-	1.6	5	M5	3.5
2006																			
2008																			
2010																			
2012																			
2018																			
2021																			
2030																			
2042																			
2056																			
2070																			
2082																			
2110	2	240	400	280	166	114	195	186	-	-	12	375	17.5	-	17.5	2.3	2.3	M6	22
2138	3	255	450	280	166	114	170	165	-	-	12	424	16	29	21	2.3	2.3	M6	24
2169		264	543	335	186	149	190	182				516	17.5	28.5	20.5			M8	39
2211																			
2257	4	312	700	420	260	160	218	218	-	-	18	659	28	43.5	28.5	4.5	4.5	M10	67
2313	5	440	800	472	254	218	370	370	-	-	20	757	28	44	30	4.5	4.5	M12	104
2360																			119
2415																			

## 400 V Class

Catalog Code GA70A	Figure	Dimensions mm														Weight kg					
		W	H	D	D1	D2	W1	W2	W3	W4	W5	H1	H2	H3	H4		t1	t2	d		
4002	1	140	260	176	138	38	102	102	-	-	-	248	6	-	-	1.6	5	M5	3.5		
4004																					
4005																					
4007																					
4009																					
4012																					
4018																					
4023																					
4031																					
4038																					
4044																					
4060																					
4075	2	240	400	280	166	114	195	186	-	-	12	375	17.5	-	17.5	2.3	2.3	M6	17		
4089	3	255	450	280	166	114	170	165	-	-	12	424	16	29	21	2.3	2.3	M6	22		
4103		264	543	335	186	149	190	182				516	17.5	28.5	20.5			2.3	2.3	M8	25
4140																					
4168																			39		
4208	4	312	700	420	260	160	218	218	-	-	18	659	28	43.5	28.5	4.5	4.5	M10	71		
4250	5	440	800	472	254	218	370	370	-	-	20	757	28	44	30	4.5	4.5	M12	122		
4296																			126		
4371																					
4389	6	510	1136	480	260	220	450	450	225	225	20	1093	25.5	43.5	30.5	4.5	4.5	M12	198		
4453																			207		
4568																					
4675																					

Note: External and mounting dimensions are different for standard mounting and panel through mounting.  
Please refer to P.37 for panel through mounting.

# Dimensions

## ■ Enclosure Wall-Mounted [UL Type1]

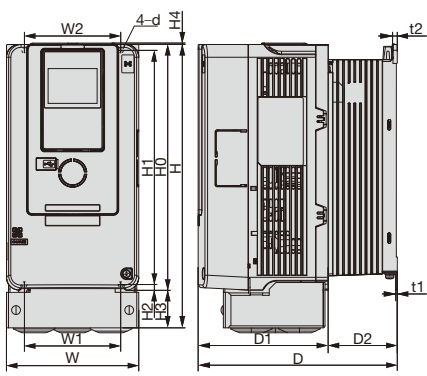

Figure 1

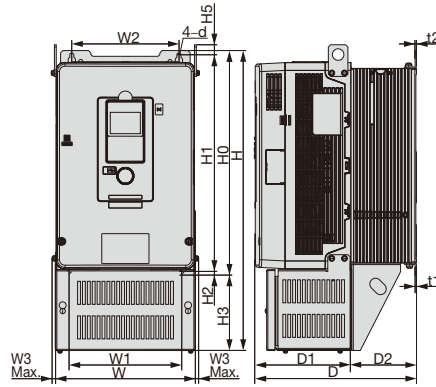

Figure 2

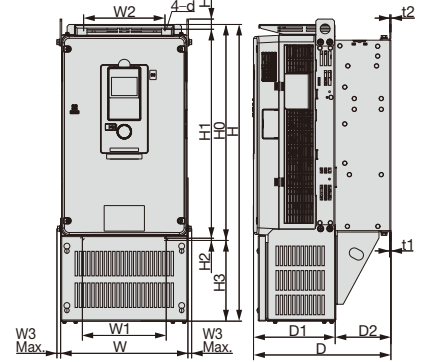

Figure 3

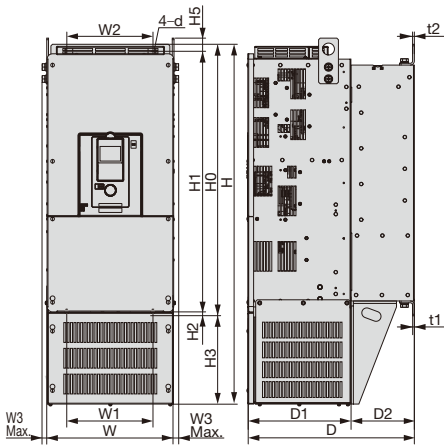

Figure 4

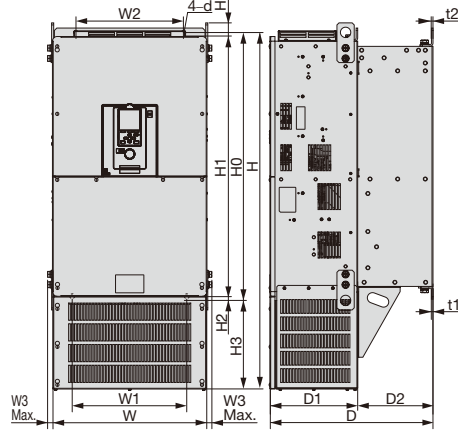

Figure 5

200 V Class: UL Type 1

Catalog Code GA70A::	Figure	Dimensions mm															Weight kg	UL Type1 Kit Code No. (Model No.)		
		W	H	D	D1	D2	W1	W2	W3	H0	H1	H2	H3	H4	H5	t1			t2	d
2004	1	140	300	176	138	38	102	102	—	260	248	6	40	1.5	—	1.6	5	M5	4.1	900-192-121-001 (100-202-326)
2006				73		4.5														
2008				211	73	4.8														
2010				211	73	4.8														
2012				211	73	4.8														
2018		211	73	4.8																
2021		211	73	4.8																
2030		211	73	4.8																
2042		211	73	4.8																
2056		180	340	202	134	68	140	140	—	300	284	8	40	—	—	—	1.6	1.6	M6	
2070	220	400	227	140	87	192	192	—	350	335	8	50	—	—	2.3	2.3	M6	9	900-192-121-003 (100-202-328)	
2082	435	—	—	—	—	—	—	—	—	—	—	85	—	—	—	—	—	—	10	900-192-121-004 (100-202-329)
2110	2	244	500	280	166	114	195	186	10	400	375	17.5	100	—	17.5	2.3	2.3	M6	24	900-192-121-005 (100-202-330)
2138	3	259	580	280	166	114	170	165	—	450	424	16	130	—	21	—	—	M6	27	900-192-121-006 (100-208-526)
2169		268	700	335	186	149	190	182	10	543	516	17.5	157	—	20.5	2.3	2.3	M8	44	900-192-121-007 (100-208-527)
2211		770	—	—	—	—	—	—	—	—	—	—	227	—	—	—	—	—	46	900-192-121-008 (100-208-528)
2257	4	316	915	420	260	160	218	218	16	700	659	28	215	—	28.5	4.5	4.5	M10	72	900-192-121-009 (100-208-549)
2313																				
2360	5	444	1045	472	254	218	370	370	18	800	757	28	245	—	30	4.5	4.5	M12	113	900-192-121-010 (100-213-136)

400 V Class: UL Type 1

Catalog Code GA70A::	Figure	Dimensions mm															Weight kg	UL Type1 Kit Code No. (Model No.)				
		W	H	D	D1	D2	W1	W2	W3	H0	H1	H2	H3	H4	H5	t1			t2	d		
4002	1	140	300	176	138	38	102	102	—	260	248	6	40	1.5	—	1.6	5	M5	4.1	900-192-121-001 (100-202-326)		
4004				73		4.5																
4005				211	73	4.8																
4007				211	73	4.8																
4009				211	73	4.8																
4012		211	73	4.8																		
4018		211	73	4.8																		
4023		211	73	4.8																		
4031		180	340	202	134	68	140	140	—	300	284	8	40	—	—	—	1.6	1.6	M6		7.0	900-192-121-002 (100-202-327)
4038		220	400	227	140	87	192	192	—	350	335	8	50	—	—	2.3	2.3	M6	8.5		900-192-121-003 (100-202-328)	
4044	246	—	—	—	—	—	—	—	—	—	—	—	—	—	—	—	—	13				
4060	246	—	—	—	—	—	—	—	—	—	—	—	—	—	—	—	—	—	13			
4075	2	244	500	280	166	114	195	186	10	400	375	17.5	100	—	17.5	2.3	2.3	M6	20	900-192-121-005 (100-202-330)		
4089	3	259	580	280	166	114	170	165	—	450	424	16	130	—	21	—	—	M6	25	900-192-121-006 (100-208-526)		
4103		268	700	335	186	149	190	182	10	543	516	17.5	157	—	20.5	2.3	2.3	M8	29			
4140		4168	770	—	—	—	—	—	—	—	—	—	—	—	—	—	—	—	—	43	900-192-121-007 (100-208-527)	
4208	4250	4296	—	—	—	—	—	—	—	—	—	—	—	—	—	—	—	—	44			
4250	4	316	915	420	260	160	218	218	16	700	659	28	215	—	28.5	4.5	4.5	M10	76	900-192-121-009 (100-208-549)		
4296																						
4371	5	444	1045	472	254	218	370	370	18	800	757	28	245	—	30	4.5	4.5	M12	130	900-192-121-010 (100-213-136)		

Note: UL Type 1 kit (option) is required. The values in the table are the dimensions of the UL Type 1 kit mounted to the IP20 open chassis type.

# Fully-Enclosed Design

The Open Chassis type drive can be installed in a fully-enclosed panel.

An open chassis model in a protective enclosure with the heatsink inside the panel allows for intake air temperature up to 50°C. The heatsink can alternatively be mounted outside the control panel, thus reducing the amount of heat inside the panel and allowing for a more compact set up.

- Cooling Design for Fully-Enclosed Panel
- Mounting the External Heatsink
- Ventilation Space

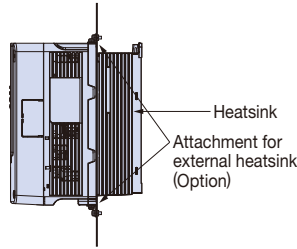
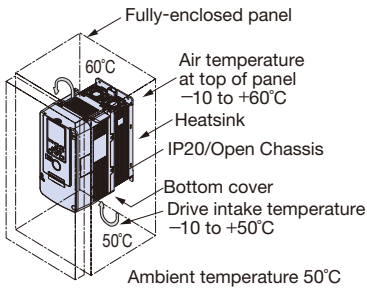

Intake air temperature for external heatsink  
 Heatsink side: 50 °C  
 Open chassis side: 50 °C  
 Use only an open chassis type for the external heatsink.

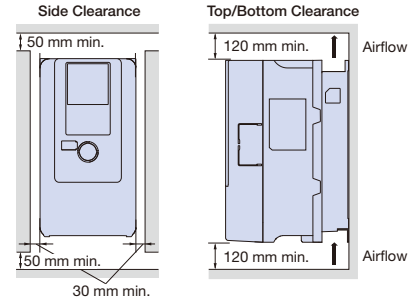

For installing the drive with capacity of 200 V class 22 kW or 400 V class 22 kW, be sure to leave enough clearance during installation for suspension brackets on both side of the unit and main circuit wiring for maintenance.

## Drive Watts Loss Data

### 200 V Class Heavy Duty Ratings

Catalog Code GA70A2:	004	006	008	010	012	018	021	030	042	056	070	082	110	138	169	211	257	313	360	415		
Rated Output Current	A	3.2	5	6.9	8	11	14	17.5	25	33	47	60	75	88	115	145	180	215	283	346	415	
Carrier Frequency	kHz	8	8	8	8	8	8	8	8	8	8	8	8	8	5	5	5	5	5	5	5	
Heat Loss*	Internal	W	23	26	30	34	42	51	56	66	73	90	108	128	138	192	227	256	329	392	504	602
	Heatsink	W	9	16	24	30	45	79	103	170	201	299	413	516	642	862	960	1106	1349	1726	2017	2405
	Total Heat Loss	W	32	42	54	64	87	130	159	236	274	389	521	644	780	1054	1187	1362	1678	2118	2521	3007

### 400 V Class Heavy Duty Ratings

Catalog Code GA70A4:	002	004	005	007	009	012	018	023	031	038	044	060	075	089	103		
Rated Output Current	A	1.8	3.4	4.8	5.5	7.2	9.2	14.8	18	24	31	39	45	60	75	91	
Carrier Frequency	kHz	8	8	8	8	8	8	8	8	8	8	8	8	8	8	8	
Heat Loss*	Internal	W	25	31	36	36	37	41	59	68	80	92	111	120	164	172	207
	Heatsink	W	14	26	37	57	64	86	140	181	260	317	452	542	730	745	971
	Total Heat Loss	W	39	57	73	93	101	127	199	249	340	409	563	662	894	917	1178

Catalog Code GA70A4:	140	168	208	250	296	371	414	453	568	675		
Rated Output Current	A	112	150	180	216	260	304	371	414	453	605	
Carrier Frequency	kHz	5	5	5	5	5	5	5	2	2	2	
Heat Loss*	Internal	W	230	310	351	382	443	422	425	754	744	910
	Heatsink	W	986	1491	1520	1662	2097	1624	1696	1996	1887	2735
	Total Heat Loss	W	1216	1801	1871	2044	2540	2046	2121	2750	2631	3645

### 200 V Class Normal Duty Ratings

Catalog Code GA70A2:	004	006	008	010	012	018	021	030	042	056	070	082	110	138	169	211	257	313	360		
Rated Output Current	A	3.5	6	8	9.6	12.2	17.5	21	30	42	56	70	82	110	138	169	211	257	313	360	
Carrier Frequency	kHz	2	2	2	2	2	2	2	2	2	2	2	2	2	2	2	2	2	2	2	
Heat Loss*	Internal	W	23	27	31	37	44	52	61	72	83	96	114	128	153	201	250	283	377	416	526
	Heatsink	W	10	17	24	32	44	83	119	205	255	341	442	503	752	956	1121	1286	1695	1914	2130
	Total Heat Loss	W	33	44	55	69	88	135	180	277	338	437	556	631	905	1157	1371	1569	2072	2330	2656

### 400 V Class Normal Duty Ratings

Catalog Code GA70A4:	002	004	005	007	009	012	018	023	031	038	044	060	075	089	103		
Rated Output Current	A	2.1	4.1	5.4	7.1	8.9	11.9	17.5	23.4	31	38	44	59.6	74.9	89.2	103	
Carrier Frequency	kHz	2	2	2	2	2	2	2	2	2	2	2	2	2	2	2	
Heat Loss*	Internal	W	24	29	34	35	37	41	58	72	80	90	100	120	153	168	190
	Heatsink	W	10	20	27	52	59	86	139	200	274	307	390	584	729	757	927
	Total Heat Loss	W	34	49	61	87	96	127	197	272	354	397	490	704	882	925	1117

  

Catalog Code GA70A4:	140	168	208	250	296	371	389	453	568	675		
Rated Output Current	A	140	168	208	250	296	371	389	453	568	675	
Carrier Frequency	kHz	2	2	2	2	2	2	2	2	2	2	
Heat Loss*	Internal	W	263	314	367	401	457	492	543	790	871	940
	Heatsink	W	1243	1571	1675	1810	2252	2027	2387	2204	2615	2878
	Total Heat Loss	W	1506	1885	2042	2211	2709	2519	2930	2994	3486	3818

\* Heat loss is calculated in the following conditions:  
 · 200 V class: Input voltage 220 V, power frequency 60 Hz, load ratio 100%  
 · 400 V class: Input voltage 440 V, power frequency 60 Hz, load ratio 100%  
 Contact your Yaskawa or nearest agent when not calculating heat loss in the above conditions.

## ● Attachment for External Heatsink

When the heatsink is installed outside the drive, additional attachments are required. Additional attachments are not required for models GA70A2110 and above, and GA70A4075 and above because installing a heatsink outside the drive can be performed on these models by replacing their standard mounting feet. Contact Yaskawa if an instruction manual is needed.

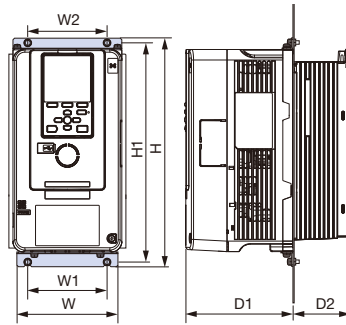

## ● Panel Modification for External Heatsink

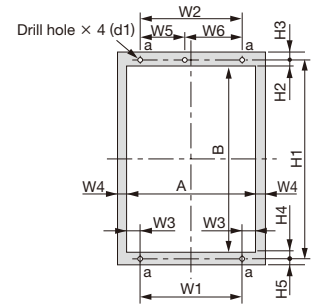
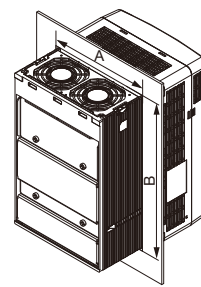

Panel cut out dimensions

Note: The shaded area is the size when in installing the gasket. Guarantee a wider and higher gasket width space than the following W and H information.

### 200 V Class

Catalog Code GA70::	Dimensions mm																Attachment for External Heatsink Code No. (Model No.)
	W	H	D1	D2	W1	W2	W3	W4	H1	H2	H3	H4	H5	A	B	d1	
2004	140	294	138	38	102	102	16	3	282	23	6	26	6	134	233	M5	900-193-209-001 (100-203-229)
2006																	
2008																	
2010				73													
2012																	
2018																	
2021																	
2030	180	329	134	68	140	140	17	3	318	23.5	5	24.5	6	174	270	M5	900-193-209-002 (100-203-230)
2042																	
2056	220	384	140	87	192	192	11	3	371	27	7	25	6	214	319	M6	900-193-209-003 (100-203-231)
2070																	
2082	240	400	166	114	195	204	14.5	8	385	19.5	7.5	19.5	7.5	224	346	M6	—
2110																	
2138	255	450	166	114	170	210	34.5	8	436	20	8	20	6	239	396	M6	—
2169																	
2211	264	543	186	149	190	220	29	8	527	19.5	8.5	20.5	7.5	248	487	M8	—
2257																	
2313	312	700	260	160	218	263	39	8	675	33	12	32	13	296	610	M10	—
2360																	
2415	440	800	254	218	370	310	23	12	773	31.5	14	31.5	13	416	710	M12	—
2415																	

### 400 V Class

Catalog Code GA70::	Dimensions mm																Attachment for External Heatsink Code No. (Model No.)		
	W	H	D1	D2	W1	W2	W3	W4	W5	W6	H1	H2	H3	H4	H5	A		B	d1
4002	140	294	138	38	102	102	16	3	—	—	282	23	6	26	6	134	233	M5	900-193-209-001 (100-203-229)
4004																			
4005																			
4007				73															
4009																			
4012																			
4018																			
4023	180	329	134	68	140	140	17	3	—	—	318	23.5	5	24.5	6	174	270	M5	900-193-209-002 (100-203-230)
4031																			
4038	220	384	140	87	192	192	11	3	—	—	371	27	7	25	6	214	319	M6	900-193-209-003 (100-203-231)
4044																			
4060	240	400	166	114	195	204	14.5	8	—	—	385	19.5	7.5	19.5	7.5	224	346	M6	—
4075																			
4089	255	450	166	114	170	210	34.5	8	—	—	436	20	8	20	6	239	396	M6	—
4103																			
4140	264	543	186	149	190	220	29	8	—	—	527	19.5	8.5	20.5	7.5	248	487	M8	—
4168																			
4208	312	700	260	160	218	263	39	8	—	—	675	33	12	32	13	296	610	M10	—
4250																			
4296	440	800	254	218	370	310	23	12	—	—	773	31.5	14	31.5	13	416	710	M12	—
4371																			
4389	510	1140	260	220	450	404	18	12	179	225	1110	34	15	34	15	486	1042	M12	—
4453																			
4568																			
4675																			

# Peripheral Devices and Options

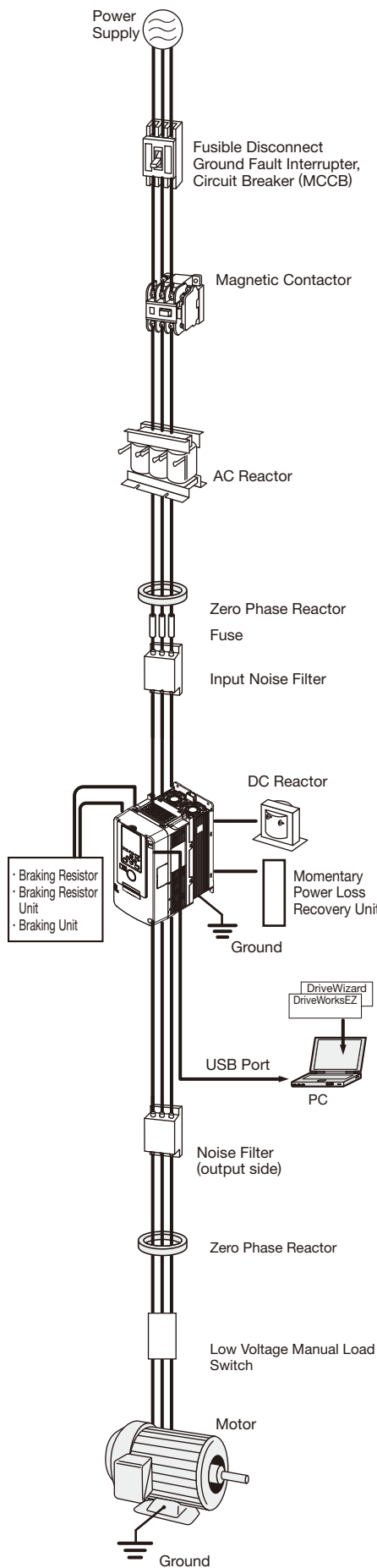

Name	Purpose	Model, Manufacturer	Page
Ground Fault Interrupter (GFI)	Always install a GFI on the power-supply side to protect the power supply system and to prevent an overload at the occurrence of shortcircuit, and to protect the drive from ground faults that could result in electric shock or fire. Note: When a GFI is installed for the upper power supply system, an MCCB can be used instead of a GFI. Choose a GFI designed to minimize harmonics specifically for AC drives. Use one GFI per drive, each with a current rating of at least 30 mA.	NV series* by Mitsubishi Electric Corporation	P.40
Circuit Breaker	Always install a circuit breaker on the power-supply side to protect the power supply system and to prevent an overload at the occurrence of a short-circuit.	NF series* by Mitsubishi Electric Corporation	P.40
Magnetic Contactor	Interrupts the power supply to the drive. In addition to protecting drive circuitry, a magnetic contactor also prevents damage to a braking resistor if used.	SC series* by Fuji Electric FA Components & Systems Co., Ltd	P.41
AC Reactor	Improve the input power ratio of the drive. The DC reactor is built in for models of catalog codes GA70 □ 2110 and above, and GA70 □ 4060 and above. (The DC reactor is optional for models of catalog codes GA70 □ 2082 and below, and GA70 □ 4044 and below.)	UZBA series	P.42
DC Reactor	· Used for harmonic current suppression and total improving power factor. · Should be used if the power supply capacity is larger than 600 kVA. · Suppresses harmonic current · Improves the power factor of the input power supply	UZDA series	P.44
Zero Phase Reactor	Reduces noise from the line that enters into the drive input power system. Should be installed as close as possible to the drive. Can be used on both the input and output sides.	F6045GB F11080GB by Hitachi Metals, Ltd.	P.45
Fuse / Fuse Holder	Protects internal circuitry in the event of component failure. Fuse should be connected to the input terminal of the drive. Note: Refer to the instruction manual for information on UL approval.	FWH series by BUSSMANN	P.46
Capacitor-Type Noise Filter	Reduces noise from the line that enters into the drive input power system. The noise filter can be used in combination with a zero-phase reactor. Note: Available for drive input only. Do not connect the noise filter to the output terminals.	3XYG 1003 by Okaya Electric Industries Co., Ltd.	P.51
Input Noise Filter	Reduces noise from the line that enters into the drive input power system. Should be installed as close as possible to the drive. Note: For CE Marking (EMC Directive) compliant models, refer to GA700 Technical Manual.	LNFD series LNFB series FN series	P.48
Output Noise Filter	Reduces noise from the line that enters into the drive input power system. Should be installed as close as possible to the drive.	LF series by NEC Tokin Corporation	P.50
Braking Resistor	Used to shorten the deceleration time by dissipating regenerative energy through a resistor. Usage 3% ED, requires a separate attachment.	ERF-150WJ series CF120-B579 series	P.52
Attachment for Braking Resistor	A braking resistor can be attached to the drive.	900-192-126-001	P.57
External Heatsink Attachment for Braking Unit	Use the external heatsink attachment for installation with the heatsink outside the enclosure.	EZZ021711A	P.57
Braking Resistor Unit	Used to shorten the deceleration time by dissipating regenerative energy through a resistor unit (10% ED). A thermal overload relay is built in (10% ED).	LKEB series	P.52
Braking Unit	Shortened deceleration time results when used with a Braking Resistor Unit.	CDBR series	P.52
PC cable	Connect the drive and PC when using DriveWizard or DriveWorksEZ. The cable length must be 3 m or less.	Commercially available USB2.0 A-miniB cable.	P.59
LED Keypad	For easier operation using the LED screen when connecting the optional LED Keypad to the drive. Allows for remote operation. Includes a Copy function for saving drive settings.	JVOP-KPLEA04AAA	P.58
Bluetooth LCD Keypad	Bluetooth connection enables the drive to be operated from a smartphone.	JVOP-KPLCC04AAA	P.58
Keypad Extension Cable	It is used as an extension cable when operating the keypad remotely.	WV001: 1 m WV003: 3 m	P.58
Momentary Power Loss Recovery Unit	Ensures continuous drive operation for a power loss of up to 2 s.	P0010 Type (200 V class) P0020 Type (400 V class)	P.51
Frequency Meter, Current Meter		DCF-6A	P.60
Frequency Setting Potentiometer (2 kΩ)		RV30YN20S 2 kΩ	P.60
Frequency Meter Adjusting Potentiometer (20 kΩ)	Allows the user to set and monitor the frequency, current, and voltage using an external device.	RV30YN20S 20 kΩ	P.60
Control Dial for Frequency Setting Potentiometer		CM-3S	P.60
Output Voltage Meter		SCF-12NH	P.61
Potential Transformer		UPN-B	P.61
Attachment for External Heatsink	Required for heatsink installation. Current derating may be needed when using a heatsink.	—	P.37
Low Voltage Manual Load Switch	Prevents shock from the voltage created on the terminals board from a coasting synchronous motor.	AICUT, LB series* by Aichi Electric Works Co., Ltd	—

\*: Recommended by Yaskawa. Contact the manufacturer in question for availability and specifications of non-Yaskawa products.

# Option Cards

RoHS compliant. Shipment of factory installed option is available. Contact Yaskawa.

Type	Name	Model	Function	Manual No.
Speed Reference Card	Analog Input	AI-A3	Enables high-precision and high-resolution analog speed reference setting. · Input signal level: -10 to +10 Vdc (20 kΩ), 4 to 20 mA (250 Ω) · Input channels: 3 channels, DIP switch for input voltage/input current selection · Input resolution: Input voltage 13 bit signed (1/8192) Input current 1/4096	TOBPC73060078
	Digital Input	DI-A3	Enables 16-bit digital speed reference setting. · Input signal: 16 bit binary, 2 digit BCD +sign signal +set signal · Input voltage: 24 V (isolated) · Input current: 8 mA User-set: 8 bit, 12 bit, 16 bit	TOBPC73060080
Communications Option Card	MECHATROLINK- II Interface	SI-T3	Used for running or stopping the drive, setting or referencing parameters, and monitoring output frequency, output current, or similar items through MECHATROLINK- II communication with the host controller. Note: Use options with software versions of 6108 or later.	TOBPC73060086 SIEPC73060086
	MECHATROLINK- III Interface	SI-ET3	Used for running or stopping the drive, setting or referencing parameters, and monitoring output frequency, output current, or similar items through MECHATROLINK- III communication with the host controller. Note: Use options with software versions of 6202 or later.	TOBPC73060088 SIEPC73060088
	CC-Link Interface	SI-C3	Used for running or stopping the drive, setting or referencing parameters, and monitoring output frequency, output current, or similar items through CC-Link communication with the host controller.	TOBPC73060083 SIEPC73060083
	DeviceNet Interface	SI-N3	Used for running or stopping the drive, setting or referencing parameters, and monitoring output frequency, output current, or similar items through DeviceNet communication with the host controller. Note: Use options with software versions of 1114 or later.	TOBPC73060084 SIEPC73060084
	LONWORKS Interface	SI-W3	Used for HVAC control, running or stopping the drive, setting or referencing parameters, and monitoring output current, watt-hours, or similar items through LONWORKS communications with the host controller.	TOBPC73060093 SIEPC73060093
	PROFIBUS-DP Interface	SI-P3	Used for running or stopping the drive, setting or referencing parameters, and monitoring output frequency, output current, or similar items through PROFIBUS-DP communication with the host controller.	TOBPC73060082 SIEPC73060082
	CANopen Interface	SI-S3	Used for running or stopping the drive, setting or referencing parameters, and monitoring output frequency, output current, or similar items through CANopen communication with the host controller.	TOBPC73060085 SIEPC73060085
	EtherCAT Interface	SI-ES3*	Used for running or stopping the drive, setting or referencing parameters, and monitoring output frequency, output current, or similar items through EtherCAT communication with the host controller.	-
	EtherNet/IP Interface	SI-EN3*	Used for running or stopping the drive, setting or referencing parameters, and monitoring output frequency, output current, or similar items through EtherNet/IP communication with the host controller.	-
	Modbus TCP/IP Interface	SI-EM3*	Used for running or stopping the drive, setting or referencing parameters, and monitoring output frequency, output current, or similar items through Modbus TCP/IP communication with the host controller.	-
	PROFINET Interface	SI-EP3*	Used for running or stopping the drive, setting or referencing parameters, and monitoring output frequency, output current, or similar items through PROFINET communication with the host controller.	-
Monitor Option Card	Analog Monitor	AO-A3	Outputs analog signal for monitoring drive output state (output freq., output current etc.). · Output resolution: 11 bit signed (1/2048) · Output voltage: -10 to +10 Vdc (non-isolated) · Terminals: 2 analog outputs	TOBPC73060079
	Digital Output	DO-A3	Outputs isolated type digital signal for monitoring drive run state (alarm signal, zero speed detection, etc.) · Terminals: 6 photocoupler outputs (48 V, 50 mA or less) 2 relay contact outputs (250 Vac, 1 A or less 30 Vdc, 1 A or less)	TOBPC73060081
PG Speed Controller Card	Complimentary Type PG	PG-B3	For control modes requiring a PG encoder for motor feedback. · Phase A, B, and Z pulse (3-phase) inputs (complementary type) · Max. input frequency: 50 kHz · Pulse monitor output: Open collector, 24 V, max. current 30 mA · Power supply output for PG: 12 V, max. current 200 mA Note: Not available in Advanced Open Loop Vector for PM.	TOBPC73060075
	Line Driver PG	PG-X3	For control modes requiring a PG encoder for motor feedback or PM motor feedback. · Phase A, B, and Z pulse (differential pulse) inputs (RS-422) · Max. input frequency: 300 kHz · Pulse monitor output: RS-422 · Power supply output for PG: 5 V or 12 V, max. current 200 mA	TOBPC73060076
	Motor Encoder Feedback (EnDat, HIPERFACE) Interface	PG-F3	For control modes requiring a PG encoder for PM motor feedback. Encoder type: EnDat 2.1/01, EnDat 2.2/01, and EnDat 2.2/22 (HEIDENHAIN), HIPERFACE (SICK STEGMANN) Maximum input frequency: 20 kHz (Used with low-speed gearless motors.) Note: EnDat 2.2/22 does not have maximum input frequency. Wiring length: 20 m max. for the encoder, 30 m max. for the pulse monitor Pulse monitor: Matches RS-422 level Note: EnDat 2.2/22 is not available. [Encoder power supply: 5 V, max current 330 mA or 8 V, max current 150 mA]  Use one of the following encoder cables. EnDat2.1/01, EnDat2.2/01 : 17-pin cable from HEIDENHAIN EnDat2.2/22 : 8-pin cable from HEIDENHAIN HIPERFACE : 8-pin cable from SICK STEGMANN	TOBPC73060077
	Resolver Interface for TS2640N321E64	PG-RT3	For control modes requiring a PG encoder for motor feedback or PM motor feedback. Can be connected to the TS2640N321E64 resolver made by Tamagawa Seiki Co., Ltd. and electrically compatible resolvers. The representative electrical characteristics of the TS2640N321E64 are as follows. · Input voltage: 7 Vac rms 10 kHz · Transformation ratio: 0.5 ± 5% · maximum input current: 100 mArms · Wiring length: 10 m max. (100 m max. for the SS5 and SS7 series motor manufactured by Yaskawa Motor Co., and PG cables manufactured by Yaskawa Controls Co., Ltd.)	TOBPC73060087

\* Contact Yaskawa for EtherCAT, EtherNet/IP, Modbus TCP/IP and PROFINET.

Note: 1. Each communication option card requires a separate configuration file to link to the network.  
2. PG speed controller card is required for PG control.

# Peripheral Devices and Options (continued)

## Ground Fault Interrupter, Circuit Breaker

Device selection is based on the motor capacity. Make sure that the rated breaking capacity is higher than the shortcircuit current for the power supply. Protect the wiring to withstand the short-circuit current for the power supply using a combination of fuses if the rated breaking capacity of the circuit breaker or ground fault interrupter is insufficient, such as when the power transformer capacity is large.



Ground Fault Interrupter  
[Mitsubishi Electric Corporation]



Circuit Breaker  
[Mitsubishi Electric Corporation]

### 200 V Class

Motor Capacity (kW)	Ground Fault Interrupter						Circuit Breaker					
	Without Reactor*1			With Reactor*1			Without Reactor*1			With Reactor*1		
	Model	Rated Current (A)	Interrupt Capacity (kA) Icu/Ics*2	Model	Rated Current (A)	Interrupt Capacity (kA) Icu/Ics*2	Model	Rated Current (A)	Interrupt Capacity (kA) Icu/Ics*2	Model	Rated Current (A)	Interrupt Capacity (kA) Icu/Ics*2
0.4	NV32-SV	5	10/10	NV32-SV	5	10/10	NF32-SV	5	7.5/7.5	NF32-SV	5	7.5/7.5
0.75	NV32-SV	10	10/10	NV32-SV	10	10/10	NF32-SV	10	7.5/7.5	NF32-SV	10	7.5/7.5
1.1	NV32-SV	15	10/10	NV32-SV	10	10/10	NF32-SV	15	7.5/7.5	NF32-SV	10	7.5/7.5
1.5												
2.2	NV32-SV	20	10/10	NV32-SV	15	10/10	NF32-SV	20	7.5/7.5	NF32-SV	15	7.5/7.5
3	NV32-SV	30	10/10	NV32-SV	20	10/10	NF32-SV	30	7.5/7.5	NF32-SV	20	7.5/7.5
3.7												
5.5	NV63-SV	50	15/15	NV63-SV	40	15/15	NF63-SV	50	15/15	NF63-SV	40	15/15
7.5	NV125-SV	60	50/50	NV63-SV	50	15/15	NF125-SV	60	50/50	NF63-SV	50	15/15
11	NV125-SV	75	50/50	NV125-SV	75	50/50	NF125-SV	75	50/50	NF125-SV	75	50/50
15	NV250-SV	125	85/85	NV125-SV	100	50/50	NF250-SV	125	85/85	NF125-SV	100	50/50
18.5	NV250-SV	150	85/85	NV250-SV	125	85/85	NF250-SV	150	85/85	NF250-SV	125	85/85
22	-	-	-	NV250-SV	150	85/85	-	-	-	NF250-SV	150	85/85
30	-	-	-	NV250-SV	175	85/85	-	-	-	NF250-SV	175	85/85
37	-	-	-	NV250-SV	225	85/85	-	-	-	NF250-SV	225	85/85
45	-	-	-	NV400-SW	250	85/85	-	-	-	NF400-CW	250	50/25
55	-	-	-	NV400-SW	300	85/85	-	-	-	NF400-CW	300	50/25
75	-	-	-	NV400-SW	400	85/85	-	-	-	NF400-CW	400	50/25
90	-	-	-	NV630-SW	500	85/85	-	-	-	NF630-CW	500	50/25
110	-	-	-	NV630-SW	600	85/85	-	-	-	NF630-CW	600	50/25

\*1: The AC or DC reactor is connected to the drive.

\*2: Icu: Rated ultimate short-circuit breaking capacity Ics: Rated service short-circuit breaking capacity

Note: 200 V models 22 kW and above come with a built-in DC reactor that improves the power factor.

### 400 V Class

Motor Capacity (kW)	Ground Fault Interrupter						Circuit Breaker					
	Without Reactor*1			With Reactor*1			Without Reactor*1			With Reactor*1		
	Model	Rated Current (A)	Interrupt Capacity (kA) Icu/Ics*2	Model	Rated Current (A)	Interrupt Capacity (kA) Icu/Ics*2	Model	Rated Current (A)	Interrupt Capacity (kA) Icu/Ics*2	Model	Rated Current (A)	Interrupt Capacity (kA) Icu/Ics*2
0.4	NV32-SV	5	5/5	NV32-SV	5	5/5	NF32-SV	3	2.5/2.5	NF32-SV	3	2.5/2.5
0.75	NV32-SV	5	5/5	NV32-SV	5	5/5	NF32-SV	5	2.5/2.5	NF32-SV	5	2.5/2.5
1.5	NV32-SV	10	5/5	NV32-SV	10	5/5	NF32-SV	10	2.5/2.5	NF32-SV	10	2.5/2.5
2.2	NV32-SV	15	5/5	NV32-SV	10	5/5	NF32-SV	15	2.5/2.5	NF32-SV	10	2.5/2.5
3	NV32-SV	20	5/5	NV32-SV	15	5/5	NF32-SV	20	2.5/2.5	NF32-SV	15	2.5/2.5
3.7												
5.5	NV32-SV	30	5/5	NV32-SV	20	5/5	NF32-SV	30	2.5/2.5	NF32-SV	20	2.5/2.5
7.5	NV32-SV	30	5/5	NV32-SV	30	5/5	NF32-SV	30	2.5/2.5	NF32-SV	30	2.5/2.5
11	NV63-SV	50	7.5/7.5	NV63-SV	40	7.5/7.5	NF63-SV	50	7.5/7.5	NF63-SV	40	7.5/7.5
15	NV125-SV	60	25/25	NV63-SV	50	7.5/7.5	NF125-SV	60	25/25	NF63-SV	50	7.5/7.5
18.5	NV125-SV	75	25/25	NV125-SV	60	25/25	NF125-SV	75	25/25	NF125-SV	60	25/25
22	-	-	-	NV125-SV	75	25/25	-	-	-	NF125-SV	75	25/25
30	-	-	-	NV125-SV	100	25/25	-	-	-	NF125-SV	100	25/25
37	-	-	-	NV250-SV	125	36/36	-	-	-	NF250-SV	125	36/36
45	-	-	-	NV250-SV	150	36/36	-	-	-	NF250-SV	150	36/36
55	-	-	-	NV250-SV	175	36/36	-	-	-	NF250-SV	175	36/36
75	-	-	-	NV250-SV	225	36/36	-	-	-	NF250-SV	225	36/36
90	-	-	-	NV400-SW	250	42/42	-	-	-	NF400-CW	250	25/13
110	-	-	-	NV400-SW	300	42/42	-	-	-	NF400-CW	300	25/13
132	-	-	-	NV400-SW	350	42/42	-	-	-	NF400-CW	350	25/13
160	-	-	-	NV400-SW	400	42/42	-	-	-	NF400-CW	400	25/13
200	-	-	-	NV630-SW	500	42/42	-	-	-	NF600-CW	630	36/18
220	-	-	-	NV630-SW	630	42/42	-	-	-	NF600-CW	630	36/18
250	-	-	-	NV630-SW	630	42/42	-	-	-	NF600-CW	630	36/18
315	-	-	-	NV800-SEW	800	42/42	-	-	-	NF800-CEW	800	36/18
355	-	-	-	NV800-SEW	800	42/42	-	-	-	NF800-CEW	800	36/18

\*1: The AC or DC reactor is connected to the drive.

\*2: Icu: Rated ultimate short-circuit breaking capacity Ics: Rated service short-circuit breaking capacity

Note: 400 V models 22 kW and above come with a built-in DC reactor that improves the power factor.



# Magnetic Contactor

Base device selection on motor capacity.

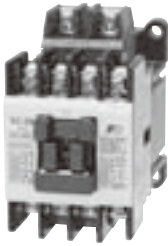

**Magnetic Contactor**  
[Fuji Electric FA Components & Systems Co., Ltd.]

## Wiring a Magnetic Contactor in Parallel

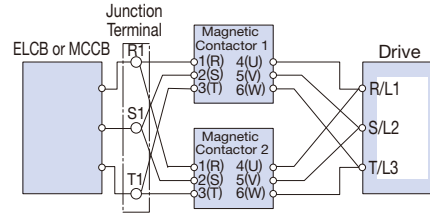

Note: When wiring contactors in parallel, make sure wiring lengths are the same to keep current flow even to the relay terminals.

## 200 V Class

Motor Capacity (kW)	Without Reactor*		With Reactor*	
	Model	Rated Current (A)	Model	Rated Current (A)
0.4	SC-03	11	SC-03	11
0.75	SC-05	13	SC-03	11
1.1	SC-4-0	18	SC-05	13
1.5	SC-4-0	18	SC-05	13
2.2	SC-N1	26	SC-4-0	18
3	SC-N2	35	SC-N1	26
3.7	SC-N2	35	SC-N1	26
5.5	SC-N2S	50	SC-N2	35
7.5	SC-N3	65	SC-N2S	50
11	SC-N4	80	SC-N4	80
15	SC-N5A	93	SC-N4	80
18.5	SC-N5	93	SC-N5	93
22	—	—	SC-N6	125
30	—	—	SC-N7	152
37	—	—	SC-N8	180
45	—	—	SC-N10	220
55	—	—	SC-N11	300
75	—	—	SC-N12	400
90	—	—	SC-N12	400
110	—	—	SC-N14	600

Note: 200 V models 22 kW and above come with a built-in DC reactor that improves the power factor.

## 400 V Class

Motor Capacity (kW)	Without Reactor*		With Reactor*	
	Model	Rated Current (A)	Model	Rated Current (A)
0.4	SC-03	7	SC-03	7
0.75	SC-03	7	SC-03	7
1.5	SC-05	9	SC-05	9
2.2	SC-4-0	13	SC-4-0	13
3	SC-4-1	17	SC-4-1	17
3.7	SC-4-1	17	SC-4-1	17
5.5	SC-N2	32	SC-N1	25
7.5	SC-N2S	48	SC-N2	32
11	SC-N2S	48	SC-N2S	48
15	SC-N3	65	SC-N2S	48
18.5	SC-N3	65	SC-N3	65
22	—	—	SC-N4	80
30	—	—	SC-N4	80
37	—	—	SC-N5	90
45	—	—	SC-N6	110
55	—	—	SC-N7	150
75	—	—	SC-N8	180
90	—	—	SC-N10	220
110	—	—	SC-N11	300
132	—	—	SC-N11	300
160	—	—	SC-N12	400
200	—	—	SC-N12	400
220	—	—	SC-N14	600
250	—	—	SC-N14	600
315	—	—	SC-N16	800
355	—	—	SC-N16	800

\* The AC or DC reactor is connected to the drive.  
Note: 400 V models 22 kW and above come with a built-in DC reactor that improves the power factor.

# Peripheral Devices and Options (continued)

## AC Reactor (UZBA-B for 50/60 Hz Input)

Base device selection on motor capacity.

### Lead Wire Type



### Connection Diagram

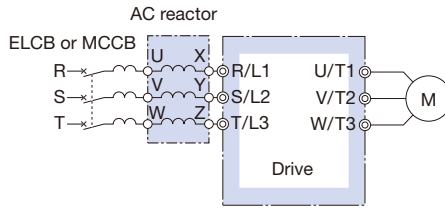

Note: When using low noise type drives (high-carrier frequency of 2.5 kHz or more), do not connect an AC reactor to the output side (U, V, W) of the drive.

### Dimensions (mm)

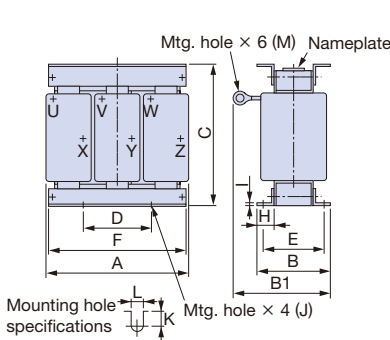

Figure 1

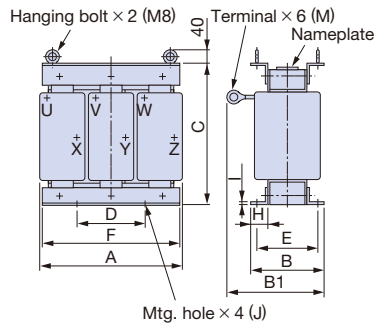

Figure 2

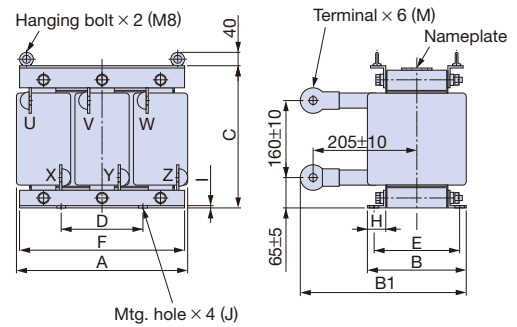

Figure 3

### 200 V Class

Motor Capacity (kW)	Current (A)	Inductance (mH)	Code No.	Figure	Dimensions (mm)											Weight (kg)	Watt Loss (W)				
					A	B	B1	C	D	E	F	H	I	J	K			L	M		
3	20	0.53	X002491	1	130	88	114	105	50	70	130	22	3.2	M6	11.5	7	M5	3	35		
3.7							119			80					9					M6	4
5.5	30	0.35	X002492			160	105	147.5	130	75	85	160	25	2.3	M6	10	7	M6	6	65	
7.5	40	0.265	X002493					155													150
11	60	0.18	X002495				180	100	150	150	75	80	180	25	2.3	M6	10	7	M8	8	90
15	80	0.13	X002497						155												
18.5	90	0.12	X002498		210		100	170	175	75	80	205	25	3.2	M6	10	7	M10	12	100	
22	120	0.09	X002555					115			182.5										95
30	160	0.07	X002556			240	126	218	215	150	110	240	25	3.2	M8	8	7	M10	23	125	
37	200	0.05	X002557																		115
45	240	0.044	X002558			270	162	241	230	150	130	260	40	5	M8	16	10	M12	32	145	
55	280	0.039	X002559																		115
75	360	0.026	X002560	270	162	241	230	150	130	260	40	5	M8	16	10	M12	32	145			
90	500	0.02	X010145																115	182.5	95
110	500	0.02	X010145	2	330	162	281	270	150	130	320	40	4.5	M10	16	10	M12	55	200		

### 400 V Class

Motor Capacity (kW)	Current (A)	Inductance (mH)	Code No.	Figure	Dimensions (mm)											Weight (kg)	Watt Loss (W)			
					A	B	B1	C	D	E	F	H	I	J	K			L	M	
7.5	20	1.06	X002502	1	160	90	115	130	75	70	160	25	2.3	M6	10	7	M5	5	50	
11	30	0.7	X002503			105	132.5			85										160
15	40	0.53	X002504		180	100	140	150	75	80	180	25	2.3	M6	10	7	M6	8	90	
18.5	50	0.42	X002505				145													150
22	60	0.36	X002506			210	100	150	175	75	80	205	25	3.2	M6	10	7	M8	12	95
30	80	0.26	X002508					115			177.5									
37	90	0.24	X002509			240	126	193	205	150	110	240	25	3.2	M8	8	10	M10	23	130
45	120	0.18	X002566					198												
55	150	0.15	X002567		270	162	231	230	150	130	260	40	5	M8	16	10	M10	32	135	
75	200	0.11	X002568				246													230
90	250	0.09	X002569		270	162	246	230	150	130	260	40	5	M8	16	10	M12	32	135	
110	250	0.09	X002569				246													230
132	330	0.06	X002570	2	320	165	253	275	150	130	320	40	4.5	M10	17.5	12	M12	55	200	
160	330	0.06	X002570																	165
200	490	0.04	X002690	2	330	176	293	275	150	150	320	40	4.5	M10	13	12	M12	60	340	
220	490	0.04	X002690																	176
250	490	0.04	X002690	3	330	216	353	285	150	185	320	40	4.5	M10	22	12	M16	80	300	
315	660	0.03	300-032-353																	216
355	660	0.03	300-032-353	3	330	216	353	285	150	185	320	40	4.5	M10	22	12	M16	80	300	

### Terminal Type

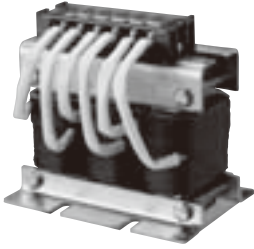

### Dimensions (mm)

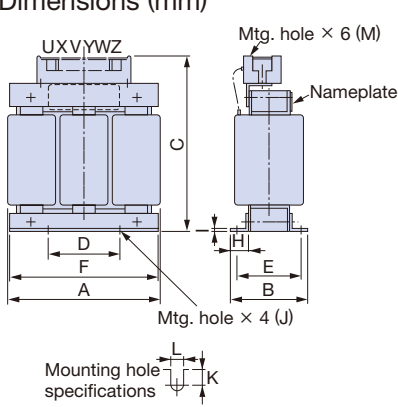

Figure 1

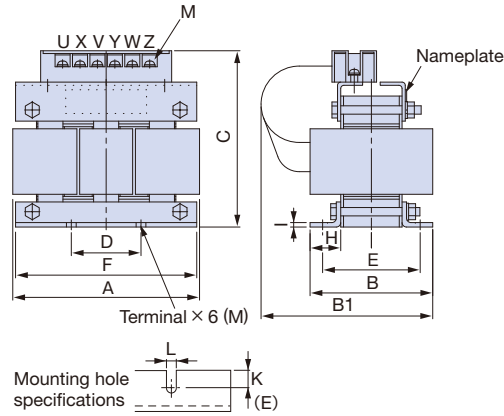

Figure 2

### 200 V Class

Motor Capacity (kW)	Current (A)	Inductance (mH)	Code No.	Figure	Dimensions (mm)											Weight (kg)	Watt Loss (W)				
					A	B	B1	C	D	E	F	H	I	J	K			L	M		
0.4	2.5	4.2	X002553	1	120	71	-	120	40	50	105	20	2.3	M6	10.5	7	M4	2.5	15		
0.75	5	2.1	X002554		130	88		130	50	70	130	22	3.2					9	3	25	
1.1	10	1.1	X002489		2.2	15		0.71	X002490	3	30										
1.5	15	0.71	X002490		3	20		0.53	300-027-120	3	35										
3	20	0.53	300-027-120	2	135	88	140	130	50	70	130	22	3.2	M6	9	7	M5	4	50		
3.7	30	0.35	300-027-121		150	45															
5.5	40	0.265	300-027-122		135	98	160	140	50	80	130	22	3.2					9	M6	6	65
7.5	60	0.18	300-027-123		165	105	185	170	75	85	160	25	2.3					10	M6	6	65
11	80	0.13	300-027-124		185	100	180	195	75	80	180	25	2.3					10	M6	8	75
15	80	0.13	300-027-124		8	90															
18.5	90	0.12	300-027-125		90																

### 400 V Class

Motor Capacity (kW)	Current (A)	Inductance (mH)	Code No.	Figure	Dimensions (mm)											Weight (kg)	Watt Loss (W)					
					A	B	B1	C	D	E	F	H	I	J	K			L	M			
0.4	1.3	18	X002561	1	120	71	-	120	40	50	105	20	2.3	M6	10.5	7	M4	2.5	15			
0.75	2.5	8.4	X002562		130	88		130	50	70	130	22	3.2					9	3	25		
1.5	5	4.2	X002563		2.2	7.5		3.6	X002564	4	40											
2.2	7.5	3.6	X002564		3	10		2.2	X002500	3	40											
3	10	2.2	X002500	2	130	88	-	130	50	70	130	22	3.2	M6	9	7	M4	4	50			
3.7	15	1.42	X002501		98	50																
5.5	20	1.06	300-027-126		165	90		160	155	75	70	160	25					2.3	10	M4	5	50
7.5	30	0.7	300-027-127		105	175		175	155	75	85	160	25					2.3	10	M4	6	65
11	40	0.53	300-027-128		185	100		170	185	75	80	180	25					2.3	10	M5	8	90
15	40	0.53	300-027-128		8	50																
18.5	50	0.42	300-027-129		90																	

# Peripheral Devices and Options (continued)

## DC Reactor (UZDA-B for DC circuit)

Base device selection on motor capacity.

Terminal Type

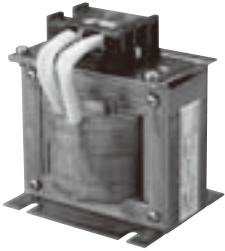

Dimensions (mm)

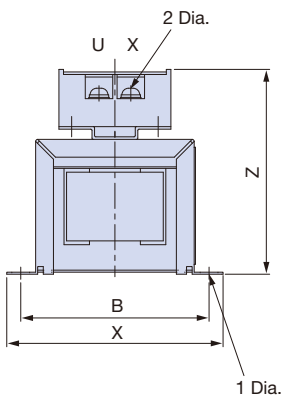

Figure 1

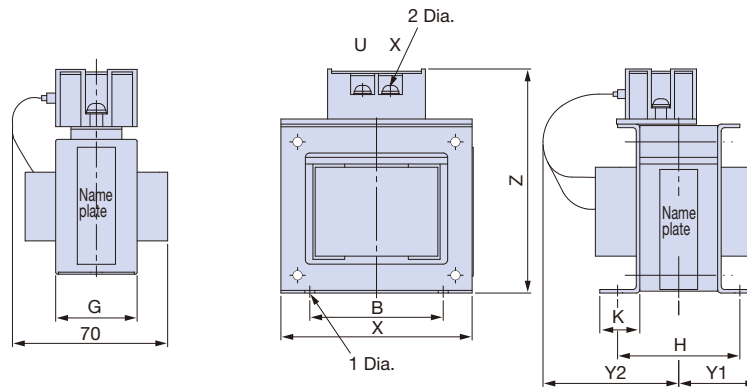

Figure 2

200 V Class

Motor Capacity (kW)	Current (A)	Inductance (mH)	Code No.	Figure	Dimensions (mm)										Weight (kg)	Watt Loss (W)
					X	Y2	Y1	Z	B	H	K	G	φ1	φ2		
0.4	5.4	8	300-027-130	1	85	—	—	81	74	—	—	32	M4	M4	0.8	8
0.75																
1.1	18	3	300-027-131	2	86	84	36	101	60	55	18	—	M4	M4	2	18
1.5																
2.2																
3																
3.7																
5.5	36	1	300-027-132	2	105	94	46	129	64	80	26	—	M6	M4	3.2	22
7.5																
11	72	0.5	300-027-133	2	105	124	56	135	64	100	26	—	M6	M6	4.9	29
15																
18.5	90	0.4	300-027-139	2	133	147.5	52.5	160	86	80	25	—	M6	M6	6.5	44

400 V Class

Motor Capacity (kW)	Current (A)	Inductance (mH)	Code No.	Figure	Dimensions (mm)										Weight (kg)	Watt Loss (W)
					X	Y2	Y1	Z	B	H	K	G	φ1	φ2		
0.4	3.2	28	300-027-134	1	85	—	—	81	74	—	—	32	M4	M4	0.8	9
0.75																
1.5	5.7	11	300-027-135	1	90	—	—	88	80	—	—	32	M4	M4	1	11
2.2																
3	12	6.3	300-027-136	2	86	84	36	101	60	55	18	—	M4	M4	2	16
3.7																
5.5	23	3.6	300-027-137	2	105	104	46	118	64	80	26	—	M6	M4	3.2	27
7.5																
11	33	1.9	300-027-138	2	105	109	51	129	64	90	26	—	M6	M4	4	26
15																
18.5	47	1.3	300-027-140	2	115	142.5	57.5	136	72	90	25	—	M6	M5	6	42

# Zero Phase Reactor

Zero-phase reactor should match wire gauge.\*  
 \* Current values for wire gauges may vary based on electrical codes. The table below lists selections based on Japanese electrical standards and Yaskawa's ND rating. Contact Yaskawa for questions regarding UL. Pass each wire (U/T1, V/T2, W/T3) through the core 4 times. Noise will be more effectively reduced when more wire is wrapped. If the wire is thick and cannot be wrapped around the core, pass it through in series of no less than 4 cores.

## Finemet Zero-Phase Reactor to Reduce Radio Noise

Note: Finemet is a registered trademark of Hitachi Metals, Ltd.



[Hitachi Metals, Ltd.]

### Connection Diagram

Compatible with the input and output side of the drive.

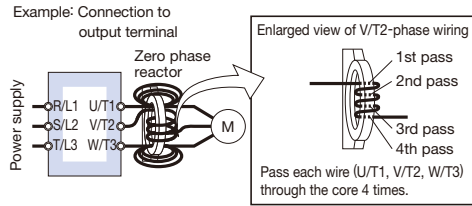
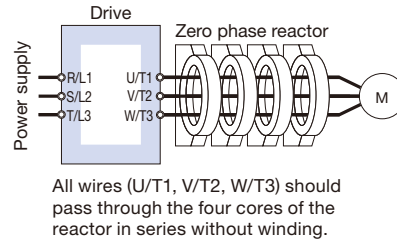
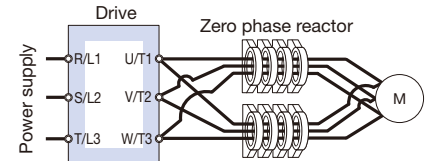

Diagram a



All wires (U/T1, V/T2, W/T3) should pass through the four cores of the reactor in series without winding.

Diagram b



Separate each terminal lead for U/T1, V/T2, and W/T3 in half, passing one half of the wires through a set of four cores and the other half through the other set of four cores as shown.

Diagram c

### Dimensions (mm)

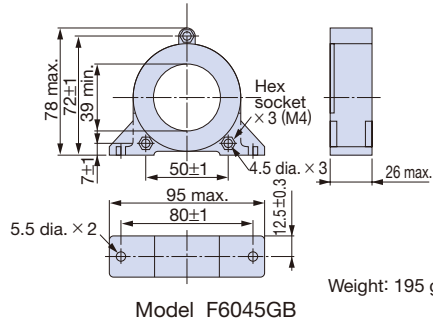

Model F6045GB

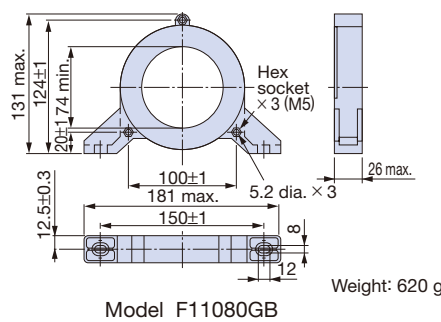

Model F11080GB

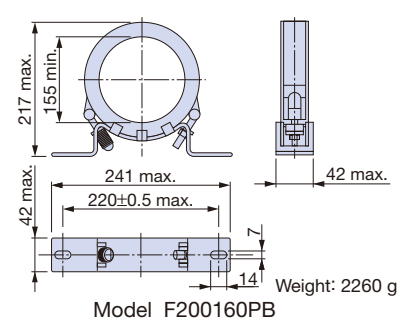

Model F200160PB

### 200 V Class

Motor Capacity (kW)	Zero Phase Reactor									
	CR700		Input Side				Output Side			
	Input Side	Output Side	Model	Code No.	Qty.	Diagram	Model	Code No.	Qty.	Diagram
0.4	2	2	F6045GB	FIL001098	1	a	F6045GB	FIL001098	1	a
0.75										
1.1										
1.5										
2.2										
3	3.5	2	F6045GB	FIL001098	1	a	F6045GB	FIL001098	1	a
3.7	3.5	3.5	F6045GB	FIL001098	1	a	F6045GB	FIL001098	1	a
5.5	8	3.5	F11080GB	FIL001097	1	a	F6045GB	FIL001098	1	a
7.5	14	8	F6045GB	FIL001098	4	b	F11080GB	FIL001097	1	a
11	14	14	F6045GB	FIL001098	4	b	F6045GB	FIL001098	4	b
15										
18.5										
22										
30										
22	50	30	F11080GB	FIL001097	4	b	F6045GB	FIL001098	4	b
30	38	38	F6045GB	FIL001098	4	b	F6045GB	FIL001098	4	b
37	60	60	F11080GB	FIL001097	4	b	F11080GB	FIL001097	4	b
45										
55										
75										
90										
110	80×2P	80×2P	F200160PB	300-001-041	4	b	F200160PB	300-001-041	4	b

Depending on the loading conditions of the motor, when a wire is selected that is not of the recommended gauge, select a zero-phase reactor using the table below.

Wiring Gauge Guide mm <sup>2</sup>	Model	Code No.	Qty.	Diagram
2 to 5.5 or less	F6045GB	FIL001098	1	a
More than 5.5 to 8	F11080GB	FIL001097	1	
More than 8 to 38	F6045GB	FIL001098	4*	b
More than 38 to 200, more than 38×2P to 50×2P	F11080GB	FIL001097	4*	
More than 200 to 250, more than 50×2P to 150×4P	F200160PB	300-001-041	4*	
More than 150×4P to 150×8P	F200160PB	300-001-041	8*	

### 400 V Class

Motor Capacity (kW)	Zero Phase Reactor																			
	CR700		Input Side				Output Side													
	Input Side	Output Side	Model	Code No.	Qty.	Diagram	Model	Code No.	Qty.	Diagram										
0.4	2	2	F6045GB	FIL001098	1	a	F6045GB	FIL001098	1	a										
0.75																				
1.5																				
2.2																				
3																				
3.7																				
5.5																				
7.5											3.5	3.5	F6045GB	FIL001098	1	a	F6045GB	FIL001098	1	a
11											8	5.5	F11080GB	FIL001097	1	a	F6045GB	FIL001098	1	a
15											14	8	F6045GB	FIL001098	4	b	F11080GB	FIL001097	1	a
18.5	14	14	F6045GB	FIL001098	4	b	F6045GB	FIL001098	4	b										
22																				
30																				
37																				
45																				
55	38	38	F6045GB	FIL001098	4	b	F6045GB	FIL001098	4	b										
75	60	60	F11080GB	FIL001097	4	b	F11080GB	FIL001097	4	b										
90																				
110																				
132																				
160	80×2P	80×2P									F200160PB	300-001-041	4	b	F200160PB	300-001-041	4	b		
200	125×2P	125×2P	F200160PB	300-001-041	4	b	F200160PB	300-001-041	4	b										
220	125×4P	100×4P	F200160PB	300-001-041	4	b	F200160PB	300-001-041	4	b										
250																				
315																				
355																				

\* The selection of 4 or more zero-phase reactors assumes that the wires are thick and cannot be wrapped. When the wires can be wrapped, you can reduce the number of reactors used.

# Peripheral Devices and Options (continued)

## Fuse and Fuse Holder

Install a fuse to the drive input terminals to prevent damage in case a fault occurs. Refer to the instruction manual for information on UL-approved components. [BUSSMANN]

### Connection Diagram

This example shows a DC power supply (two drives connected in series). For an AC power supply, see the connection diagram on page 24.

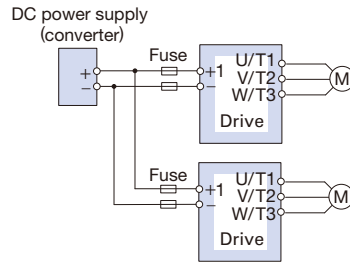

Note: When connecting multiple drives together, make sure that each drive has its own fuse. If any one fuse blows, all fuses should be replaced.

### 200 V Class

Catalog Code GA70A	AC Power Supply Input					DC Power Supply Input				
	Fuse			Fuse Holder		Fuse			Fuse Holder	
	Model	Rated Shortcircuit Breaking Current (kA)	Qty.	Model	Qty.	Model	Rated Shortcircuit Breaking Current (kA)	Qty.	Model	Qty.
2004	FWH-45B	200	3	1BS101	6	FWH-45B	200	2	1BS101	4
2006										
2008										
2010										
2012	FWH-50B	200	3	1BS101	6	FWH-50B	200	2	1BS101	4
2018	FWH-80B	200	3	1BS101	6	FWH-80B	200	2	1BS101	4
2021										
2030	FWH-125B	200	3	1BS102	6	FWH-125B	200	2	1BS102	4
2042	FWH-150B									
2056	FWH-200B									
2070	FWH-225A									
2082	FWH-225A	200	3	1BS102	6	FWH-250A	200	2	1BS102	4
	FWH-250A*1									
2110	FWH-225A	200	3	1BS102	6	FWH-250A	200	2	1BS102	4
	FWH-250A*1									
2138	FWH-275A	200	3	1BS102	6	FWH-300A	200	2	1BS102	4
	FWH-300A*1									
2169	FWH-275A	200	3	1BS102	6	FWH-350A	200	2	1BS103	4
	FWH-350A*1									
2211	FWH-325A	200	3	1BS102	6	FWH-450A	200	2	1BS103	4
	FWH-450A*1			1BS103	6	FWH-600A*1				
2257	FWH-600A	200	3	1BS103	6	FWH-600A	200	2	1BS103	4
						FWH-700A*1			*2	
2313	FWH-800A	200	3	*2		FWH-800A	200	2	*2	
						FWH-1000A*1				
2360	FWH-1000A	200	3	*2		FWH-1000A	200	2	*2	
2415										

\*1: Yaskawa suggests that you select a lower tier fuse for applications in which a high current that is 150% or more of the drive rated current repeatedly flows, such as cranes (hoists), elevators, punching presses, and washing machines.

\*2: Manufacturer does not recommend a specific fuse holder for this fuse.

## 400 V Class

Catalog Code GA70A	AC Power Supply Input					DC Power Supply Input				
	Fuse			Fuse Holder		Fuse			Fuse Holder	
	Model	Rated Shortcircuit Breaking Current (kA)	Qty.	Model	Qty.	Model	Rated Shortcircuit Breaking Current (kA)	Qty.	Model	Qty.
4002	FWH-50B	200	3	1BS101	6	FWH-50B	200	2	1BS101	4
4004	FWH-50B	200	3	1BS101	6	FWH-50B	200	2	1BS101	4
4005										
4007										
4009	FWH-60B	200	3	1BS101	6	FWH-60B	200	2	1BS101	4
4012										
4018	FWH-80B	200	3	1BS101	6	FWH-80B	200	2	1BS101	4
4023	FWH-90B	200	3	1BS101	6	FWH-90B	200	2	1BS101	4
4031	FWH-150B	200	3	1BS102	6	FWH-150B	200	2	1BS102	4
4038	FWH-200B	200	3	1BS102	6	FWH-200B	200	2	1BS102	4
4044										
4060	FWH-225A	200	3	1BS102	6	FWH-225A	200	2	1BS102	4
4075	FWH-250A	200	3	1BS102	6	FWH-250A	200	2	1BS102	4
4089	FWH-275A	200	3	1BS102	6	FWH-275A	200	2	1BS102	4
4103										
4140	FWH-300A	200	3	1BS102	6	FWH-300A FWH-325A*1	200	2	1BS102	4
4168	FWH-325A FWH-400A*1	200	3	1BS102	6	FWH-400A FWH-450A*1	200	2	1BS103	4
4208	FWH-500A	200	3	1BS103	6	FWH-500A FWH-600A*1	200	2	1BS103	4
4250	FWH-600A	200	3	1BS103	6	FWH-600A FWH-700A*1	200	2	1BS103	4
4296	FWH-700A	200	3	1BS103 *2	6	FWH-700A FWH-800A*1	200	2	*2	*2
4371	FWH-800A	200	3	*2		FWH-800A FWH-1000A*1	200	2	*2	*2
4389	FWH-1000A	200	3	*2		FWH-1000A FWH-1200A*1	200	2	*2	*2
4453	FWH-1200A	200	3	*2		FWH-1200A FWH-1400A*1	200	2	*2	*2
4568	FWH-1200A	200	3	*2		FWH-1200A FWH-1600A*1	200	2	*2	*2
4675	FWH-1400A FWH-1600A*1	200	3	*2		FWH-1600A	200	2	*2	*2

\*1: Yaskawa suggests that you select a lower tier fuse for applications in which a high current that is 150% or more of the drive rated current repeatedly flows, such as cranes (hoists), elevators, punching presses, and washing machines.

\*2: Manufacturer does not recommend a specific fuse holder for this fuse.

# Peripheral Devices and Options (continued)

## Input Noise Filter

Base device selection on motor capacity.

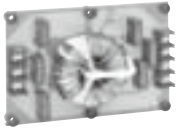

Noise Filter without Case



Noise Filter with Case



**Noise Filter**  
[Schaffner EMC K.K.]  
Note: Refer to the instruction manual for information on the CE mark and compliance with the EMC directive.

### Connection Diagram

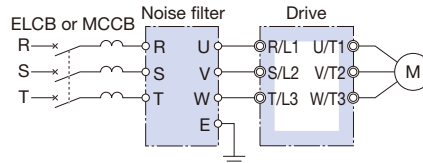

Note: Do not connect the input noise filter to the drive output terminals (U, V, W). Connect in parallel when using two filters.

Connecting Noise Filters in Parallel to the Input or Output Side (examples shows two filters in parallel)

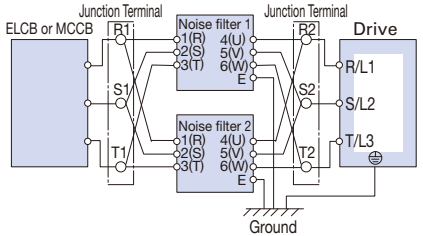

Note: When wiring contactors in parallel, make sure wiring lengths are the same to keep current flow even to the relay terminals. Noise filters and grounding wire should be as heavy and as short as possible.

### 200 V Class

Motor Capacity (kW)	Noise Filter without Case				Noise Filter with Case				Noise Filter by Schaffner EMC K.K.			
	Model	Code No.	Qty.	Rated Current (A)	Model	Code No.	Qty.	Rated Current (A)	Model	Code No.	Qty.	Rated Current (A)
0.4												
0.75	LNFD-2103DY	FIL000132	1	10	LNFD-2103HY	FIL000140	1	10	-	-	-	-
1.1												
1.5												
2.2	LNFD-2153DY	FIL000133	1	15	LNFD-2153HY	FIL000141	1	15	-	-	-	-
3												
3.7	LNFD-2303DY	FIL000135	1	30	LNFD-2303HY	FIL000143	1	30	-	-	-	-
5.5	LNFD-2203DY	FIL000134	2	40	LNFD-2203HY	FIL000142	2	40	FN258L-42-07	FIL001065	1	42
7.5			2	60			2	60	FN258L-55-07	FIL001066	1	55
11			3	90			3	90	FN258L-75-34	FIL001067	1	75
15	LNFD-2303DY	FIL000135			LNFD-2303HY	FIL000143			FN258L-100-35	FIL001068	1	100
18.5			4	120			4	120	FN258L-130-35	FIL001069	1	130
22									FN258L-130-35	FIL001069	1	130
30									FN258L-180-07	FIL001070	1	180
37												
45												
55									FN359P-250-99	FIL001071	1	250
75									FN359P-400-99	FIL001073	1	400
90									FN359P-500-99	FIL001074	1	500
110									FN359P-600-99	FIL001075	1	600

### 400 V Class

Motor Capacity (kW)	Noise Filter without Case				Noise Filter with Case				Noise Filter by Schaffner EMC K.K.			
	Model	Code No.	Qty.	Rated Current (A)	Model	Code No.	Qty.	Rated Current (A)	Model	Code No.	Qty.	Rated Current (A)
0.4												
0.75	LNFD-4053DY	FIL000144	1	5	LNFD-4053HY	FIL000149	1	5				
1.5												
2.2	LNFD-4103DY	FIL000145	1	10	LNFD-4103HY	FIL000150	1	10				
3												
3.7	LNFD-4153DY	FIL000146	1	15	LNFD-4153HY	FIL000151	1	15				
5.5	LNFD-4203DY	FIL000147	1	20	LNFD-4203HY	FIL000152	1	20				
7.5	LNFD-4303DY	FIL000148	1	30	LNFD-4303HY	FIL000153	1	30				
11	LNFD-4203DY	FIL000147	2	40	LNFD-4203HY	FIL000152	2	40	FN258L-42-07	FIL001065	1	42
15			2	60			2	60	FN258L-55-07	FIL001066	1	55
18.5			3	90			3	90	FN258L-75-34	FIL001067	1	75
22	LNFD-4303DY	FIL000148			LNFD-4303HY	FIL000153			FN258L-100-35	FIL001068	1	100
30			4	120			4	120	FN258L-100-35	FIL001068	1	100
37									FN258L-130-35	FIL001069	1	130
45									FN258L-180-07	FIL001070	1	180
55												
75									FN359P-300-99	FIL001072	1	300
90									FN359P-400-99	FIL001073	1	400
110									FN359P-500-99	FIL001074	1	500
132												
160												
200									FN359P-600-99	FIL001075	1	600
220												
250												
315									FN359P-900-99	FIL001076	1	900
355												



Without Case

Dimensions (mm)

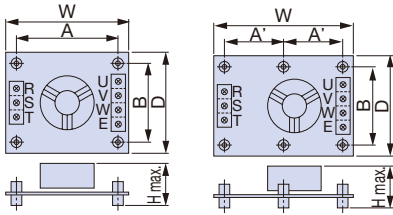
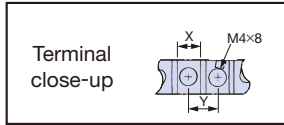

Figure 1

Figure 2



Model LNFD-□□□□	Code No.	Figure	Dimensions (mm)								Terminal (mm)		Mounting Screw	Weight (kg)
			W	D	H	A	A'	B	M	X	Y			
2103DY	FIL000132	1	120	80	55	108	—	68	20	9	11	M4×4, 20 mm	0.2	
2153DY	FIL000133	1				158	—	78		9	11			
2203DY	FIL000134	1	170	90	70	—	79	98	20	10	13	M4×6, 20 mm	0.5	
2303DY	FIL000135	2				—	79	98		10	13			
4053DY	FIL000144	2	170	130	75	—	79	118	30	9	11	M4×6, 30 mm	0.4	
4103DY	FIL000145	2				—	79	118		9	11			
4153DY	FIL000146	2	200	145	100	—	94	133	30	9	11	M4×4, 30 mm	0.5	
4203DY	FIL000147	2				—	94	133		10	13			
4303DY	FIL000148	2	—	—	—	—	—	—	—	—	—	—	0.6	

With Case

Dimensions (mm)

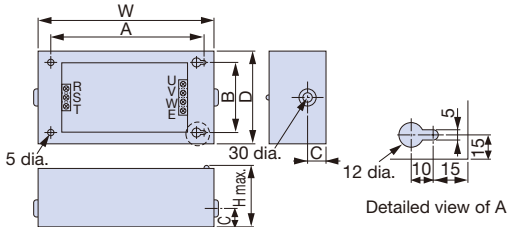

The figure shows an example of three-phase input.

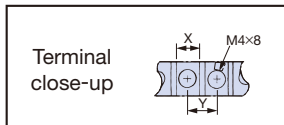

Model LNFD-□□□□	Code No.	Dimensions (mm)							Terminal (mm)		Weight (kg)
		W	D	H	A	B	C	X	Y		
2103HY	FIL000140	185	95	85	155	65	33	9	11	0.9	
2153HY	FIL000141							9	11		
2203HY	FIL000142	240	125	100	210	95	33	10	13	1.5	
2303HY	FIL000143							10	13		
4053HY	FIL000149	235	140	120	205	110	43	9	11	1.6	
4103HY	FIL000150							9	11		
4153HY	FIL000151	270	155	125	240	125	43	9	11	1.7	
4203HY	FIL000152							9	11		
4303HY	FIL000153	—	—	—	—	—	—	—	—	2.2	

Manufactured by Schaffner EMC K.K.

Dimensions (mm)

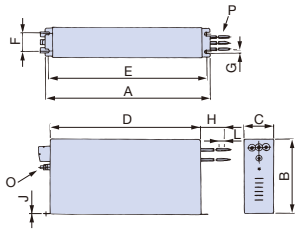

Figure 1

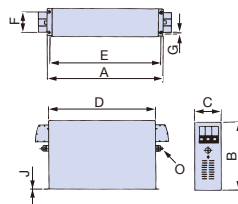

Figure 2

Model	Weight (kg)
FN359P-250-99	16
FN359P-300-99	16
FN359P-400-99	18.5
FN359P-500-99	19.5
FN359P-600-99	20.5

Model	Figure	Dimensions (mm)											Wire Gauge	Weight (kg)
		A	B	C	D	E	F	G	H	J	L	O	P	
FN258L-42-07	1	329	185±1	70	300	314	45	6.5	500	1.5	12	M6	AWG8	2.8
FN258L-55-07				80			55						AWG6	
FN258L-75-34				—			—						—	
FN258L-100-35	2	379±1.5	220	90±0.8	350±1.2	364	65	6.5	—	1.5	—	M10	—	5.5

Note: For CE Marking (EMC Directive) compliant models, contact us for inquiry.

# Peripheral Devices and Options (continued)

## Output Noise Filter

Base device selection on motor capacity.



[NEC Tokin Corporation]

Connection Diagram

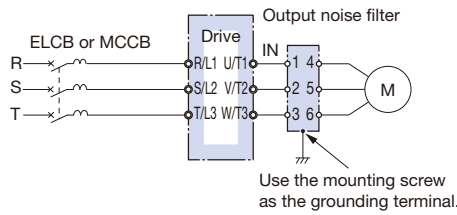

Dimensions (mm)

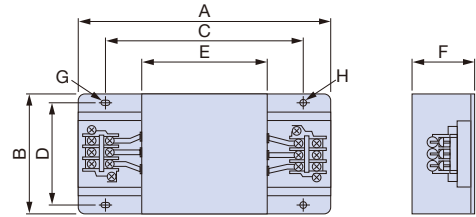

### 200 V Class

Motor Capacity (kW)	Model	Code No.	Qty.*1	Rated Current (A)	Dimensions (mm)								Terminal	Weight*2 (kg)
					A	B	C	D	E	F	G	H		
0.4	LF-310KA	FIL000068	1	10	140	100	100	90	70	45	7×φ4.5	φ4.5	TE-K5.5 M4	0.5
0.75														
1.1														
1.5														
2.2	LF-320KA	FIL000069	1	20	140	100	100	90	70	45	7×φ4.5	φ4.5	TE-K5.5 M4	0.6
3														
3.7														
5.5	LF-350KA	FIL000070	1	50	260	180	180	160	120	65	7×φ4.5	φ4.5	TE-K22 M6	2.0
7.5														
11			3	150	260	180	180	160	120	65	7×φ4.5	φ4.5	TE-K22 M6	2.0
15														
18.5														
22	LF-350KA*3	FIL000070	3	150	260	180	180	160	120	65	7×φ4.5	φ4.5	TE-K22 M6	2.0
	LF-3110KB*3	FIL000076	1	110	540	340	480	300	340	240	9×φ6.5	φ6.5	TE-K60 M8	19.5
30	LF-350KA*3	FIL000070	3	150	260	180	180	160	120	65	7×φ4.5	φ4.5	TE-K22 M6	2.0
	LF-375KB*3	FIL000075	2	150	540	320	480	300	340	240	9×φ6.5	φ6.5	TE-K22 M6	12.0
37	LF-3110KB	FIL000076	2	220	540	320	480	300	340	240	9×φ6.5	φ6.5	TE-K60 M8	19.5
45														
55														
75														
90														
110														
			3	330	540	320	480	300	340	240	9×φ6.5	φ6.5	TE-K60 M8	19.5
			4	440										
			5	550										

\*1: Connect in parallel when using more than one filter. Refer to the Connecting Noise Filters in Parallel to the Input or Output Side on page 48.

\*2: Weight of one filter.

\*3: Either noise filter model can be used.

### 400 V Class

Motor Capacity (kW)	Model	Code No.	Qty.*1	Rated Current (A)	Dimensions (mm)								Terminal	Weight*2 (kg)														
					A	B	C	D	E	F	G	H																
0.4	LF-310KB	FIL000071	1	10	140	100	100	90	70	45	7×φ4.5	φ4.5	TE-K5.5 M4	0.5														
0.75																												
1.5																												
2.2																												
3																												
3.7																												
5.5	LF-320KB	FIL000072	1	20	140	100	100	90	70	45	7×φ4.5	φ4.5	TE-K5.5 M4	0.6														
7.5																												
11																												
15	LF-335KB	FIL000073		35	260	180	180	160	120	65	7×φ4.5	φ4.5	TE-K22 M6	2.0														
18.5	LF-345KB	FIL000074	1	45																								
22	LF-375KB	FIL000075	1	75											540	320	480	300	340	240	9×φ6.5	φ6.5	TE-K22 M6	12.0				
30	LF-3110KB	FIL000076	1	110	540	340	480	300	340	240	9×φ6.5	φ6.5	TE-K60 M8	19.5														
37																												
45																												
55															LF-375KB	FIL000075	2	150	540	320	480	300	340	240	9×φ6.5	φ6.5	TE-K22 M6	12.0
75															2	220	3	330	540	320	480	300	340	240	9×φ6.5	φ6.5	TE-K60 M8	19.5
90																												
110																												
132																												
160																												
200																												
220																												
250																												
315	7	770	8	880	540	320	480	300	340	240	9×φ6.5	φ6.5	TE-K60 M8	19.5														
355																												

\*1: Connect in parallel when using more than one filter. Refer to the Connecting Noise Filters in Parallel to the Input or Output Side on page 48.

\*2: Weight of one filter.

## ● Momentary Power Loss Recovery Unit



Weight: 2 kg

### Connection Diagram

Momentary Power Loss Recovery Unit

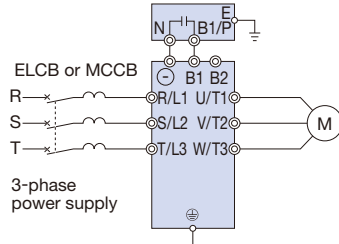

### Dimensions (mm)

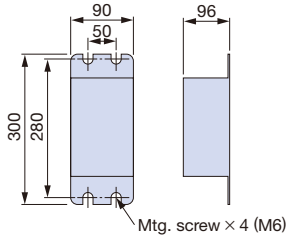

Model	Code No.
200 V Class: P0010	P0010
400 V Class: P0020	P0020

Note: Functions as a back-up power supply for drives up to 11 kW. Allows the drive to ride through a power loss up to 2 s long. The drive alone can continue running through a power loss lasting 0.1 s to 1.0 s. Results may vary with drive capacity.

## ● Capacitor-Type Noise Filter

Capacitor-type noise filter exclusively designed for drive input.

For both 200 V and 400 V classes, the noise filter can be used with a zero-phase reactor.

Note: The capacitor-type noise filter can be used for drive input only. Do not connect the noise filter to the output terminals.



[Okaya Electric Industries Co., Ltd.]

### Connection Diagram

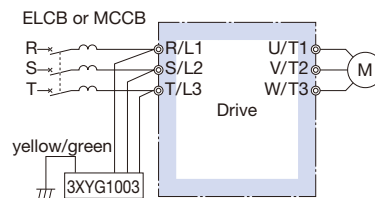

### Dimensions (mm)

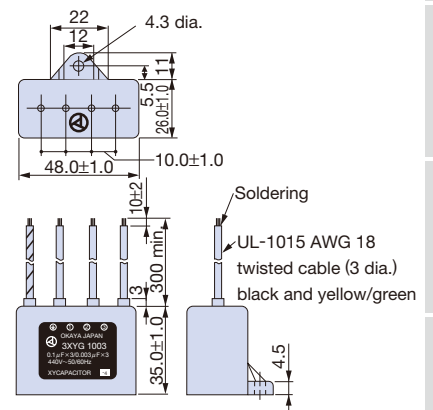

### Specifications

Model	Code No.
3XYG 1003	C002889

Rated Voltage	Capacitance (3 devices each)	Operating Temperature (°C)
440 V	X (Δ connection) : 0.1 μF ± 20 % Y (λ connection) : 0.003 μF ± 20 %	-40 to +85

Note: For use with 460 V and 480 V units, contact Yaskawa directly.

## Braking Unit, Braking Resistor, Braking Resistor Unit

Braking units and braking resistors are required to brake the drive.

However, the braking unit for drives with catalog codes GA70□2004 through 2138 and GA70□4002 through 4168 is not required since these drives have built-in braking transistors. If the application requires a braking resistor or braking unit, choose from built-in and stand-alone types in accordance with motor capacity.

When connecting a braking unit or a braking resistor unit with the catalog codes GA70□2169, GA70□2211, GA70□4140, and GA70□4168, a junction terminal is required.

Yaskawa recommends Mibu Denki Industrial Co., Ltd. as a manufacturer of the junction terminal.



Stand-alone



Braking Unit (CDBR-□□□□)  
[CDBR series]



Built-in

Braking Resistor  
[ERF-150WJ series]



Built-in

Braking Resistor with Fuse  
[CF120-B579 series]



Stand-alone



Stand-alone

Braking Resistor Unit  
[LKEB series]

### 200 V Class

Footnotes are listed on page 53.

Max. Applicable Motor (kW)	ND/HD	GA700 Catalog Code GA70A	Braking Unit		Braking Resistor (Duty Factor: 3% ED, 10 s max.)*1								Braking Resistor Unit (Duty Factor: 10% ED, 10 s max.)*1				Min.*2 Connectable Resistance (Ω)			
			Model CDBR-□□□□	Qty.	No Fuse				With Fuse				Model LKEB-□□□□	Resistor Specifications (per unit)	Qty.	Diagram		Braking Torque*3 (%)		
					Model ERF-150WJ	Resistance (Ω)	Qty.	Diagram	Braking Torque*3 (%)	Model CF120-B579	Resistance (Ω)	Qty.							Diagram	Braking Torque*3 (%)
0.4	HD	2004			201	200	1	A	220	B	200	1	A	220	20P7	70 W 200 Ω	1	B	220	48
0.75	ND	2004			201	200	1	A	125	B	200	1	A	125	20P7	70 W 200 Ω	1	B	125	48
	HD	2006			201	200	1	A	85	B	200	1	A	85	20P7	70 W 200 Ω	1	B	85	48
1.1	ND	2006			101	100	1	A	150	C	100	1	A	150	21P5	260 W 100 Ω			150	
	1.5	HD	2008			101	100	1	A	125	C	100	1	A	125	21P5	260 W 100 Ω	1	B	125
ND		2010			700	70	1	A	120	D	70	1	A	120	22P2	260 W 70 Ω	1	B	120	48
2.2	HD	2012																	16	
	ND	2012			620	62	1	A	100	E	62	1	A	100	23P7	390 W 40 Ω	1	B	150	16
3	HD	2018																		
	ND	2018			620	62	1	A	80	E	62	1	A	80	23P7	390 W 40 Ω	1	B	125	16
3.7	HD	2021																		
	ND	2021			620	62	2	A*4	110	E	62	2	A*4	110	25P5	520 W 30 Ω	1	B	115	16
5.5	HD	2030																		
	ND	2030																		
7.5	HD	2042													27P5	780 W 20 Ω	1	B	125	9.6
	ND	2042																		
11	HD	2056													2011	2400 W 13.6 Ω	1	B	125	9.6
	ND	2056																		
15	HD	2070													2015	3000 W 10 Ω	1	B	125	9.6
	ND	2070																		
18.5	HD	2082													2015	3000 W 10 Ω	1	B	85	9.6
	ND	2082													2022	4800W 6.8 Ω			125	6.4
22	HD	2110																		
	ND	2110																		
30	HD	2138													2022	4800 W 6.8 Ω	1	B	90	6.4
	ND	2138													2022	4800 W 6.8 Ω	1	B	70	6.4
37	HD	2169*5	2037D	1											2015	3000 W 10 Ω	2	F	100	5.0
	ND	2169*5	2037D	1											2015	3000 W 10 Ω	2	F	80	5.0
45	HD	2211*5	2022D	2											2022	4800 W 6.8 Ω	2	G	120	6.4
	ND	2211*5	2022D	2											2022	4800 W 6.8 Ω	2	G	100	6.4
55	HD	2257																		
	ND	2257	2110D	1											2022	4800 W 6.8 Ω	3	D	110	1.6
75	HD	2313																		
	ND	2313	2110D	1											2022	4800 W 6.8 Ω	4	D	120	1.6
90	HD	2360																		
	ND	2360	2110D	1											2018	4800 W 8 Ω	5	D	100	1.6
110	HD	2415																		

Note: 1. Braking resistor (ERF-150WJ and CF120-B579) requires a separate attachment for installation. See attachment for braking resistor unit on page 57.  
 2. Use the retrofit attachment when replacing an older model CDBR braking unit (CDBR-□□B, CDBR-□□C). Refer to TOBP C720600 01 1000-Series Option CDBR, LKEB Installation Manual for more details.  
 3. Use the External Heatsink Attachment for installation with the heatsink outside the enclosure. Refer to page 57 for details.  
 4. If the built-in fuse on a braking resistor blows, then the entire braking resistor should be replaced.  
 5. See the connection diagram on page 54.

## 400 V Class

Max. Applicable Motor (kW)	ND/HD	GA700 Catalog Code	Braking Unit		Braking Resistor (Duty Factor: 3% ED, 10 s max.)*1								Braking Resistor Unit (Duty Factor: 10% ED, 10 s max.)*1					Min.*2 Connectable Resistance (Ω)		
			Model CDBR-	Qty.	No Fuse				With Fuse				Model LKEB-	Resistor Specifications (per unit)	Qty.	Diagram	Braking Torque*3 (%)			
					Model ERF-150WJ	Resistance (Ω)	Qty.	Diagram	Braking Torque*3 (%)	Model CF120-B579	Resistance (Ω)	Qty.							Diagram	Braking Torque*3 (%)
0.4	HD	4002	Built-in		751	750	1	A	230	F	750	1	A	230	40P7	70 W 750 Ω	1	B	230	165
0.75	ND	4002		751	750	1	A	130	F	750	1	A	130	40P7	70 W 750 Ω	1	B	130	165	
	HD	4004																		
1.5	ND	4004		401	400	1	A	125	G	400	1	A	125	41P5	260 W 400 Ω	1	B	125	165	
	HD	4005																	110	
2.2	ND	4005		301	300	1	A	115	H	300	1	A	115	42P2	260 W 250 Ω	1	B	135	110	
	HD	4007																		
3	ND	4007		201	200	1	A	125	J	250	1	A	100	42P2	260 W 250 Ω	1	B	100	110	
	HD	4009												43P7	390 W 150 Ω			150	55	
3.7	ND	4009		201	200	1	A	105	J	250	1	A	83	43P7	390W 150 Ω	1	B	135	55	
	HD	4012																		
5.5	ND	4012		201	200	2	A*4	135	J	250	2	A*4	105	45P5	520 W 100 Ω	1	B	135	55	
	HD	4018																		32
7.5	ND	4018												47P5	780 W 75 Ω	1	B	130	32	
	HD	4023																		
11	ND	4023												4011	1040 W 50 Ω	1	B	135	32	
	HD	4031																		20
15	ND	4031												4015	1560 W 40 Ω	1	B	125	20	
	HD	4038																		
18.5	ND	4038												4018	4800 W 32 Ω	1	B	125	20	
	HD	4044																		19.2
22	ND	4044												4022	4800 W 27.2 Ω	1	B	125	19.2	
	HD	4060																		
30	ND	4060												4030	6000 W 20 Ω	1	B	125	19.2	
	HD	4075																		
37	ND	4075												4030	6000 W 20 Ω	1	B	100	19.2	
	HD	4089												4037	9600 W 16 Ω			125	10.6	
45	ND	4089												4045	9600 W 13.6 Ω	1	B	125	10.6	
	HD	4103																		8.7
55	ND	4103												4045	9600 W 13.6 Ω	1	B*4	100	8.7	
	HD	4140*5												4030	6000 W 20 Ω			2	H	135
75	ND	4140*5												4030	6000 W 20 Ω	2	H*4	100	7.2	
	HD	4168*5											4045	9600 W 13.6 Ω	145			5.2		
90	ND	4168*5											4045	9600 W 13.6 Ω	2	H*4 C	100	5.2		
	HD	4208	4045D	2															12.8	
110	ND	4208	4220D	1									4030	6000 W 20 Ω	3	D	100	3.2		
	HD	4250																		
132	ND	4250	4220D	1									4045	9600 W 13.6 Ω	4	D	140	3.2		
	HD	4296																		
160	ND	4296	4220D	1									4045	9600 W 13.6 Ω	4	D	140	3.2		
	HD	4371																		
200	ND	4371	4220D	1									4045	9600 W 13.6 Ω	4	D	120	3.2		
	HD	4389																		
220	ND	4389	4220D	1									4037	9600 W 16 Ω	5	D	110	3.2		
	HD	4453																		
250	ND	4453	4220D	1									4037	9600 W 16 Ω	5	D	90	3.2		
	HD	4568																		
315	ND	4568	4220D	2									4045	9600 W 13.6 Ω	6	E	100	3.2		
	HD	4675																		
355	ND	4675	4220D	2									4045	9600 W 13.6 Ω	8	E	120	3.2		

- \*1: Refers to a motor coasting to stop with a constant torque load. Constant output and regenerative braking will reduce the duty factor.
  - \*2: Assumes the use of a single braking unit. The braking unit should have a resistance higher than the minimum connectable resistance value and be able to generate enough braking torque to stop the motor.
  - \*3: Applications with a relatively large amount of regenerative power (elevators, hoists, etc.) may require more braking power than is possible with only the standard braking unit and braking resistor. If the braking torque exceeds the value shown in the table, the capacity of the braking resistor must be increased.
  - \*4: When using multiple braking resistors or braking resistor units, connect them in parallel.
  - \*5: When connecting a braking unit or a braking resistor unit with the catalog codes GA70□2169, GA70□2211, GA70□4140, and GA70□4168, a junction terminal is required. For details, see the connection diagram on the next page.
- Note: 1. Braking resistor (ERF-150WJ and CF120-B579) requires a separate attachment for installation. See attachment for braking resistor unit on page 57.  
 2. Use the retrofit attachment when replacing an older model CDBR braking unit (CDBR-□B, CDBR-□C). Refer to TOBP C720600 01 1000-Series Option CDBR, LKEB Installation Manual for more details.  
 3. Use the External Heatsink Attachment for installation with the heatsink outside the enclosure. Refer to page 57 for details.  
 4. If the built-in fuse on a braking resistor blows, then the entire braking resistor should be replaced.  
 5. See the connection diagram on page 54.

# Peripheral Devices and Options (continued)

## Connection Diagram

Footnotes are listed on page 55.

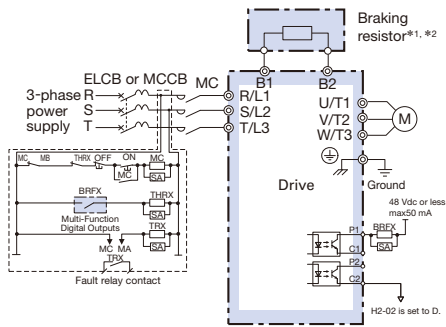

Connection Diagram A

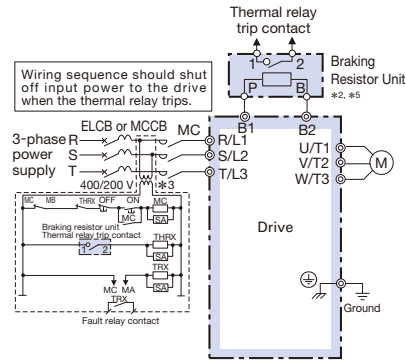

Connection Diagram B

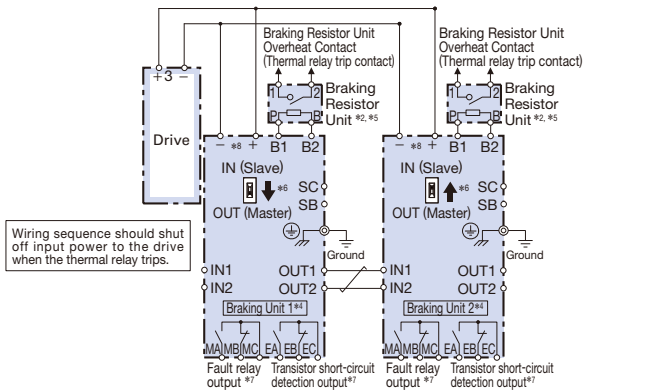

Connection Diagram C

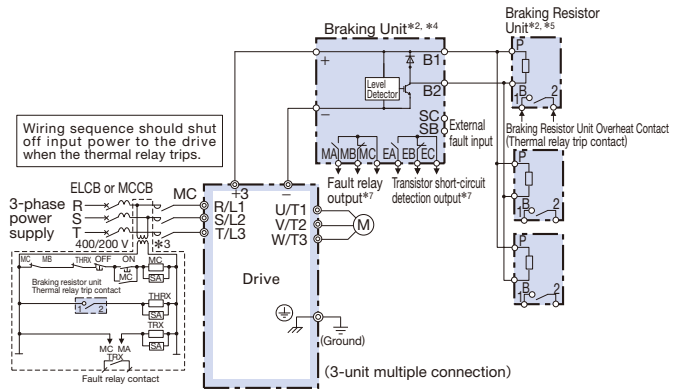

Connection Diagram D

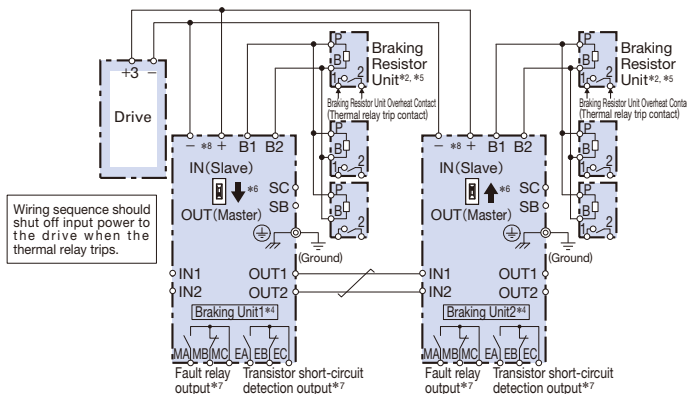

Connection Diagram E

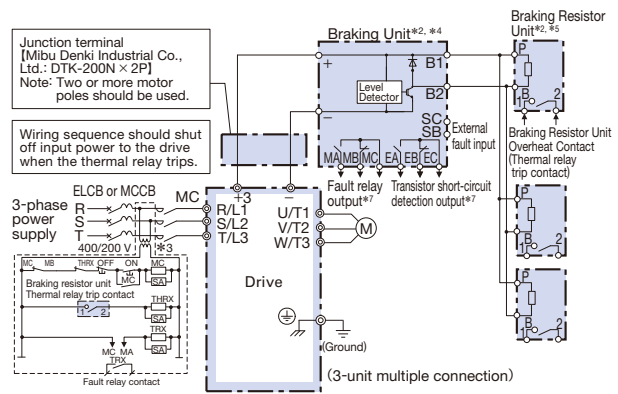

Connection Diagram F

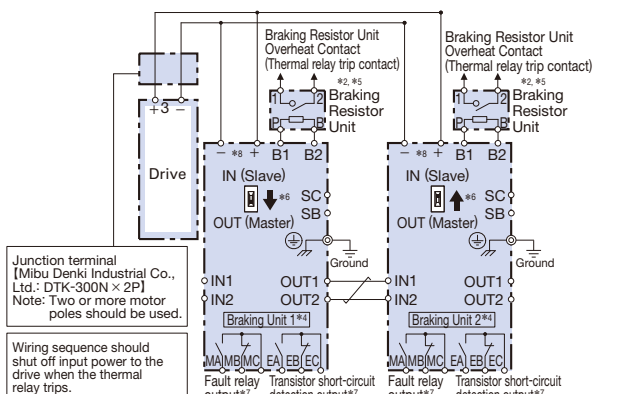

Connection Diagram G

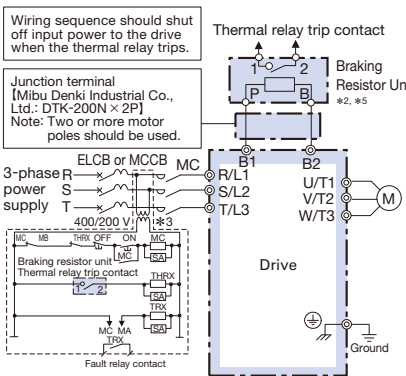

Connection Diagram H

- \*1: Set L8-01 to 1 to enable braking resistor overload protection in the drive when using braking resistors, and set a multi-function input to "Braking Resistor Fault" (H1-::: = D). Wiring sequence should shut off power to the drive when a fault output is triggered. CF120-B579 series does not need to be wired an external sequence.
- \*2: Set L3-04 to 0 or 3 to disable stall prevention when using a braking unit, a braking resistor, or a braking resistor unit. If the function is enabled under these conditions, the drive may not stop within the specified deceleration time.
- \*3: 200 V class drives do not require a control circuit transformer.
- \*4: Set L8-55 to 0 to disable the protection function for the built-in braking transistor when using a regenerative unit or another type of braking option in lieu of the built-in braking transistor. If the protection function is enabled under these conditions, it may cause a braking resistor fault (rF).  
When connecting a separately-installed type braking resistor unit (model

- CDBR) to drives with a built-in braking transistor (catalog codes GA70□ 2004 to 2138, and GA70□4002 to 4168), connect the B1 terminal of the drive to the positive terminal of the braking resistor unit and connect the negative terminal of the drive to the negative terminal of the braking resistor unit. The B2 terminal is not used in this case.
- \*5: Be sure to protect non-Yaskawa braking resistors by thermal overload relay.
- \*6: When using more than one braking unit connected in parallel, set one of the braking units as the master, and set the others as slaves.
- \*7: Connect fault relay output to multi-function digital input S::: (External Fault). Connect the CDBR transistor short-circuit detection output to disconnect main input power to the drive.
- \*8: Connect directly to the drive terminal or install a terminal block.
- \*9: Contact your Yaskawa or nearest sales representative for a replacement manual when connecting braking units CDBR-:::B, CDBR-:::C, and CDBR-:::D in parallel.

### Model, Code No. Braking Unit 200 V Class

Model CDBR-□□□□□	Protection Design	Code No.
2022D	IP20	100-091-707
	UL Type 1	100-091-754
2037D	IP20	100-091-712
	UL Type 1	100-091-759
2110D	IP00	100-091-524
	UL Type 1	100-091-530

### 400 V Class

Model CDBR-□□□□□	Protection Design	Code No.
4045D	IP20	100-091-722
	UL Type 1	100-091-769
4220D	IP00	100-091-526
	UL Type 1	100-091-532

### Heat Loss

Model CDBR-□□□□□	Heat Loss (W)
2022D	27
2037D	38
2110D	152
4045D	36
4220D	152

### Dimensions (mm) Braking Unit

#### Open Chassis [IP20]

CDBR-2022D, -2037D, -4045D

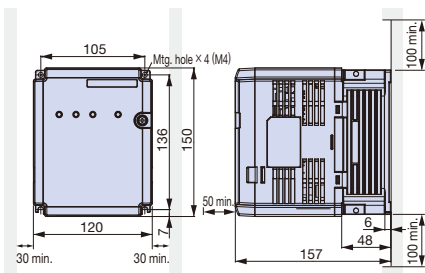

Weight: 2 kg

#### Open Chassis [IP00]

CDBR-2110D, -4220D

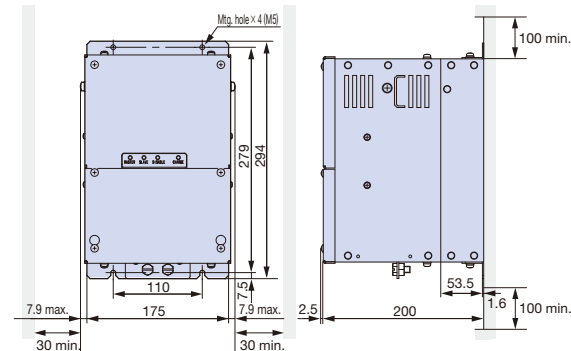

Weight: 7.5 kg

#### Enclosure Wall-Mounted [UL Type 1]

CDBR-2022D, -2037D, -4045D

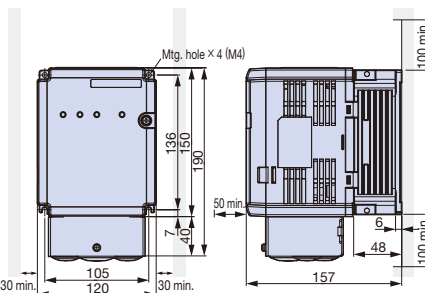

Weight: 2.3 kg

CDBR-2110D, -4220D

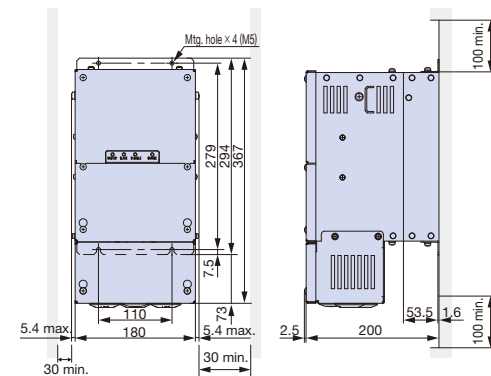

Weight: 8.3 kg

## Braking Resistor

An optional separate attachment is need to install the braking resistor to the drive.  
Refer to the Attachment for Braking Resistor on page 57.

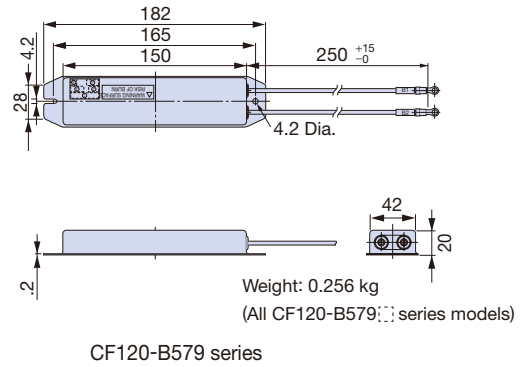
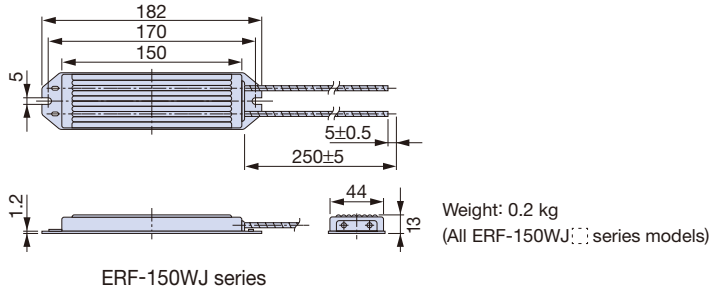

## Braking Resistor Unit (stand-alone)

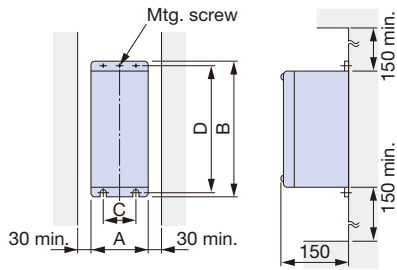

Figure 1

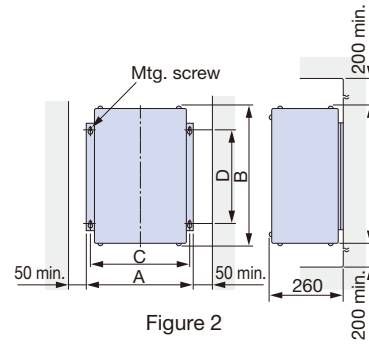

Figure 2

Applicable Voltage Class	Braking Resistor Unit Model LKEB-{:}	Figure	Dimensions (mm)					Weight (kg)	Allowable Average Power Consumption (W)
			A	B	C	D	MTG Screw		
200 V Class	20P7	1	105	275	50	260	M5×3	3.0	30
	21P5	1	130	350	75	335	M5×4	4.5	60
	22P2							4.5	89
	23P7							5.0	150
	25P5	1	250	350	200	335	M6×4	7.5	220
	27P5							8.5	300
	2011	2	446	543	426	340	M8×4	10	440
	2015							15	600
	2018							19	740
2022	19							880	

Applicable Voltage Class	Braking Resistor Unit Model LKEB-{:}	Figure	Dimensions (mm)					Weight (kg)	Allowable Average Power Consumption (W)
			A	B	C	D	MTG Screw		
400 V Class	40P7	1	105	275	50	260	M5×3	3.0	30
	41P5	1	130	350	75	335	M5×4	4.5	60
	42P2							4.5	89
	43P7							5.0	150
	45P5	1	250	350	200	335	M6×4	7.5	220
	47P5							8.5	300
	4011	2	446	543	426	340	M8×4	16	440
	4015							18	600
	4018							19	740
	4022							19	880
	4030	2	446	956	426	740	M8×4	25	1200
	4037							33	1500
	4045							33	1800



## ● Attachment for Braking Resistor

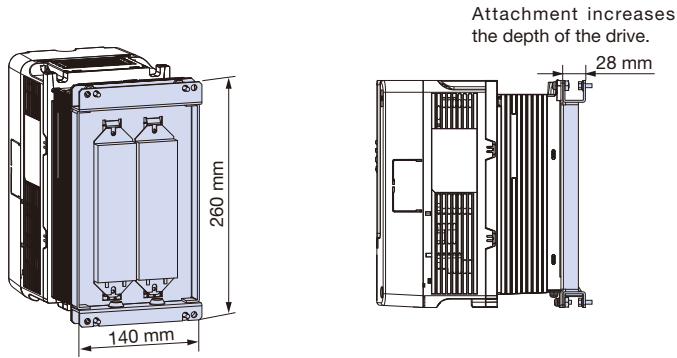

Model	Code No.
900-192-126-001	100-202-333

## ● Braking Unit External Heatsink Attachment

Use the external heatsink attachment for installation with the heatsink outside the enclosure.

Attachment	Model CDBR- [ ]	Model (Code No.)
	2022D	EZZ021711A (100-066-355)
	2037D	
	4030D	
	4045D	

Dimensions (mm)

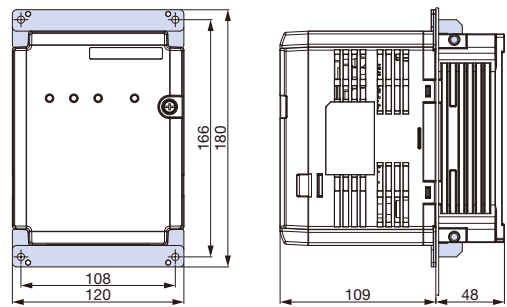

## ● Braking Unit Panel Cutout Dimensions

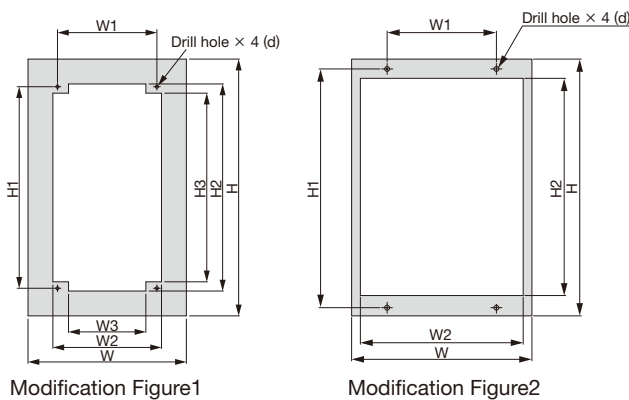

Model CDBR- [ ]	Modification Figure	Dimensions (mm)								
		W*	H*	W1	W2	W3	H1	H2	H3	d1
2022D	1	172	226	108	118	84	166	172	152	M4
2037D	1	172	226	108	118	84	166	172	152	M4
2110D	2	175	294	110	159	—	279	257.8	—	M5
4045D	1	172	226	108	118	84	166	172	152	M4
4220D	2	175	294	110	159	—	279	257.8	—	M5

\* The following W, H information is the size when in installing the gasket.

# Peripheral Devices and Options (continued)

## Bluetooth LCD Keypad

A Bluetooth communications interface is built into the LCD keypad. The drive can be connected to DriveWizard Mobile through a wireless connection.

Specification	Model	Code No.
Standard	JVOP-KPLCC04AAA	100-213-745
Humidity, dust	JVOP-KPLCC04MAA	100-213-746

- Note: 1. Available in the GA700 software versions: 1016 and later.  
 2. Certified international standards: CE, FCC, IC (Industry Canada), KC Korea, MIC Japan  
 3. This keypad is equipped with a wireless device. The usage of wireless devices may be restricted in accordance with the Radio Law in each country. Check relevant laws and regulations in each country before using the product.

Dimensions (mm)

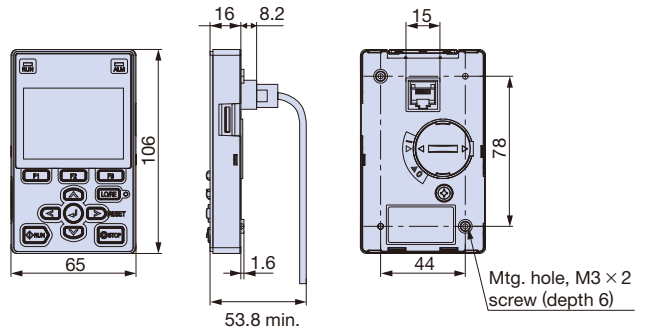

## LED Keypad

The LED keypad offers a five-digit LED display. Shipment of LED keypad as standard prepared is available. Contact Yaskawa.

Specification	Model	Code No.
Standard	JVOP-KPLEA04AAA	100-206-377
Humidity, dust	JVOP-KPLEA04MAA	100-206-378

Dimensions (mm)

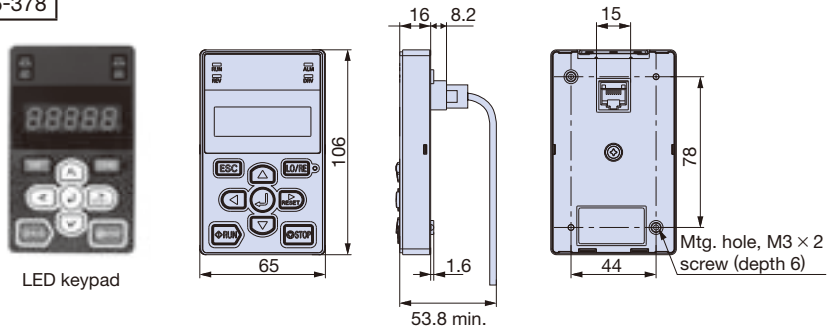

## Keypad Extension Cable

Enables remote operation.

Model	Code No.
WV001 (1 m)	WV001
WV003 (3 m)	WV003

Note: Never use this cable for connecting the drive to a PC. Doing so may damage the PC.

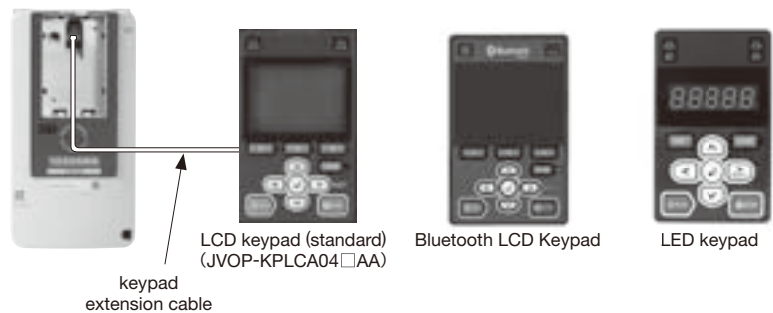

## ● Keypad Mounting Bracket

This bracket is required to mount the LCD, Bluetooth LCD Keypad, or LED keypad on the control panel.

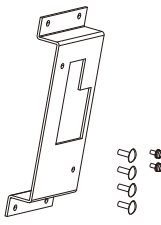
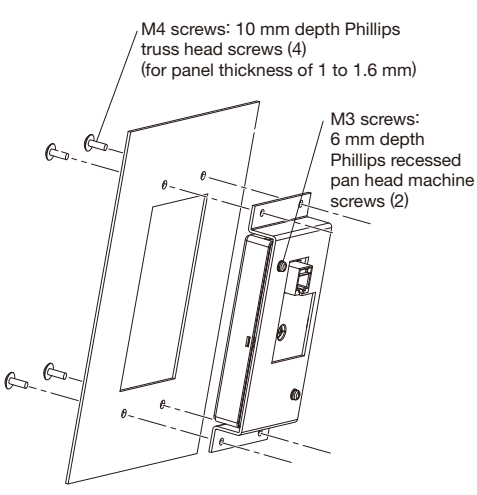
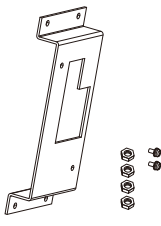
Item	Model	Code No.	Installation	Notes
 <p>Installation Support Set A</p>	900-192-933-001	100-203-008	 <p>M4 screws: 10 mm depth Phillips truss head screws (4) (for panel thickness of 1 to 1.6 mm)</p> <p>M3 screws: 6 mm depth Phillips recessed pan head machine screws (2)</p>	For use with holes through the panel
 <p>Installation Support Set B</p>	900-192-933-002	100-203-009		For use with panel mounted threaded studs

Note: If there are weld studs on the interior of the control panel, use the installation support set B (nut clamp).

## ● PC Cable

Cable to connect the drive to a PC with DriveWizard or DriveWorksEZ installed.  
Use a commercially available USB 2.0 cable (A-miniB connectors, max. 3 m).

### Connection

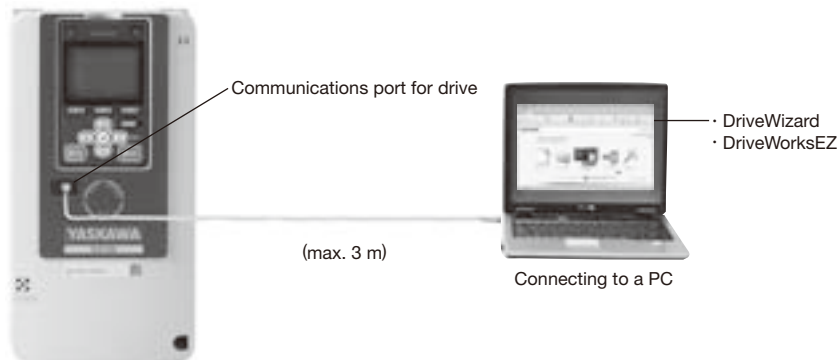

Note: DriveWizard is a PC software package for managing parameters and functions in Yaskawa drives.  
DriveWorksEZ is the software for creating custom application programs for the drive through visual programming.



## Output Voltage Meter



Model	Code No.
Scale-300 V full-scale (Rectification Type Class 2.5: SCF-12NH)	VM000481
Scale-600 V full-scale (Rectification Type Class 2.5: SCF-12NH)	VM000502

### Dimensions (mm)

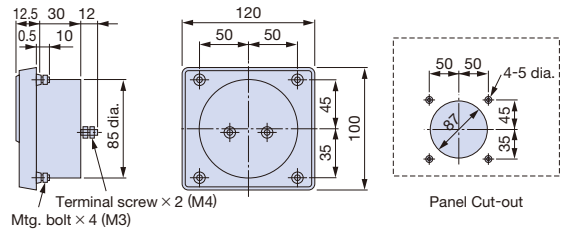

Weight: 0.3 kg

## Potential Transformer

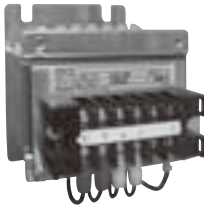

Model	Code No.
600 V meter for voltage transformer UPN-B 440/110 V (400/100 V)	100-011-486

Note: For use with a standard voltage regulator.  
A standard voltage regulator may not match the drive output voltage. Select a regulator specifically designed for the drive output (100-011-486), or a voltmeter that does not use a transformer and offers direct read out.

### Dimensions (mm)

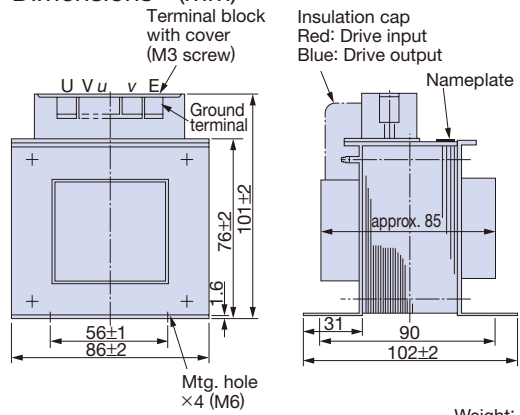

Weight: 2.2 kg

## Application Notes

### Selection

#### ■ Installing a Reactor

An AC or DC reactor can be used for the following situations:

- when the power supply is 600 kVA or more.
- to smooth peak current that results from switching a phase advance capacitor.
- to improve the power supply power factor.

The DC reactor is built in for models of catalog codes GA70□2110 and above, GA70□4060 and above.

Use an AC reactor when also connecting a thyristor converter to the same power supply system, regardless of the conditions of the power supply.

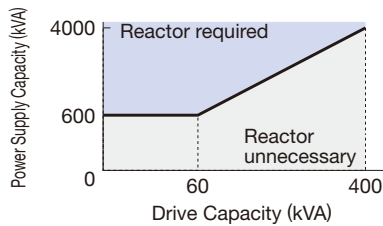

#### ■ Drive Capacity

The rated output current of the drive output amps should be equal to or greater than the motor rated current. When running a specialized motor or more than one motor in parallel from a single drive, the capacity of the drive should be larger than 1.1 times of the total motor rated current.

#### ■ Starting Torque

The overload rating for the drive determines the starting and accelerating characteristics of the motor. Expect lower torque than when running from line power. To get more starting torque, use a larger drive or increase both the motor and drive capacity.

#### ■ Emergency Stop

When the drive faults out, a protective circuit is activated and drive output is shut off. This, however, does not stop the motor immediately. Some type of mechanical brake may be needed if it is necessary to halt the motor faster than the Fast Stop function is able to.

#### ■ Options

The B1, B2, -, +1, +2 and +3 terminals are used to connect optional devices. Connect only GA700-compatible devices.

#### ■ Repetitive Starting/Stopping

Cranes (hoists), elevators, punching presses, and other such applications with frequent starts and stops often exceed 150% of their rated current values. Heat stress

generated from repetitive high current can shorten the lifespan of the IGBTs. The expected lifespan for the IGBTs is about 8 million start and stop cycles with a 2 kHz carrier frequency and a 150% peak current.

Yaskawa recommends lowering the carrier frequency, particularly when audible noise is not a concern. The user can also choose to reduce the load, increase the acceleration and deceleration times, or switch to a larger drive. This will help keep peak current levels under 150%. Be sure to check the peak current levels when starting and stopping repeatedly during the initial test run, and make adjustments accordingly.

For cranes and other applications using the inching function in which the drives starts and stops the motor repeatedly, Yaskawa recommends the following steps to ensure torque levels:

- Select a large enough drive so that peak current levels remain below 150%.
- The drive should be one frame size larger than the motor.

- As the carrier frequency of the drive is increased above the factory default setting, the drive's rated output current must be derated. Refer to the instruction manual of the drive for details on this function.

### Installation

#### ■ Enclosure Panels

Keep the drive in a clean environment by either selecting an area free of airborne dust, lint, oil mist, corrosive gas, and flammable gas, or install the drive in an enclosure panel. Leave the required space between the drives to provide for cooling, and take steps to ensure that the ambient temperature remains within allowable limits. Keep flammable materials away from the drive. If the drive must be used in an area where it is subjected to oil mist and excessive vibration, protective designs are available. Contact Yaskawa for details.

#### ■ Installation Direction

The drive should be installed upright as specified in the manual.

Although the drive can be installed on its side, an appropriate amount of airflow and current derating are required.

### Settings

- Use V/f Control when running multiple induction motors at the same time.

- If using Open Loop Vector Control or Closed Loop Vector Control for PM motors, make sure that the proper motor code has been set to parameter E5-01 before performing a trial run.
- Upper Limits  
Because the drive is capable of running the motor at up to 590 Hz, be sure to set the upper limit for the frequency to control the maximum speed. The default setting for the maximum output frequency is 60 Hz.
- Pay close attention as follows when using DriveWorksEZ.  
I/O terminal function of the drive will change with the function of the default terminal depending on the setting. Before test running the drive based on programs created by DriveWorksEZ, always check the I/O signal of the drive and the internal sequence. Failure to check may result in death or serious injury.
- Pay attention to the following points when using the Virtual I/O function.  
This function virtually wires the I/O terminal of the drive internally.  
Consequently, the behavior of the drive may differ from its defaults, even if there is no wiring in the I/O terminal. Before conducting a test operation, always check the setting values for the parameter of the Virtual I/O function. Failure to check may result in death or serious injury.
- DC Injection Braking  
Motor overheat can result if there is too much current used during DC Injection Braking, or if the time for DC Injection Braking is too long.
- Acceleration/Deceleration Times  
Acceleration and deceleration times are affected by how much torque the motor generates, the load torque, and the inertia moment ( $GD^2/4$ ). Set a longer accel/ decel time when Stall Prevention is enabled. The accel/ decel times are lengthened for as long as the Stall Prevention function is operating. For faster acceleration, increase the capacity of both the motor and the drive. For faster deceleration, use a braking resistor or a power regenerative unit.

## General Handling

- Screw Terminal Option  
Crimp terminal wiring is available as an option. Contact

Yaskawa in advance for more information on installation options.

- Cable Clamp Option  
An option for mounting a clamping device that fixes power cables to the bottom of the drive. Contact Yaskawa in advance for more information on installation options.
- Electrical Shock Hazard  
Failure to comply may result in death or serious injury. Do not allow unqualified personnel to perform work on the drive. Installation, maintenance, inspection, and servicing must be performed only by authorized personnel familiar with installation, adjustment, and maintenance of AC drives.
- Wiring Check  
Never short the drive output terminals or apply voltage to output terminals (U/T1, V/T2, W/T3), as this can cause serious damage to the drive. Doing so will destroy the drive. Be sure to perform a final check of all sequence wiring and other connections before turning the power on. Make sure there are no short circuits on the control terminals (+V, AC, etc.), as this could damage the drive. Retighten the screws for the wiring terminals periodically.
- European Terminal
  - For European terminals, do not shake the wires excessively or pull on the wires too much.
  - When connecting uninsulated wire and when crimping wire to the solderless terminal, do not let the wire protrude past the conductor section. Pay close attention to this because it could cause a short circuit. Check for any unsuitable wire size connections.
  - Righten at the specified torque.
- European Terminal Wiring Work  
Heed the following points. Follow the procedure in the manual concerning all points except the following.
  - Use the torque driver or a torque wrench and ratchet. The tip of a straight-edge screwdriver or a hex socket tool is required for wiring the European terminal.
  - Wiring tools can be purchased from Yaskawa. Contact Yaskawa. The torque wrench should be supplied by the customer.
  - To replace a previous model, the wires that are used may be partially out of connection range. Contact Yaskawa beforehand about the available wire gauges.

# Application Notes

## ■ Wiring Using Closed-loop Crimp Terminals

Wrench-type or closed-wrench type tools cannot be used with drives with catalog codes of GA70□2257 and above or 4208 and above. Make sure to always use socket-type tools. Use only sockets with a depth of 30 mm or more.

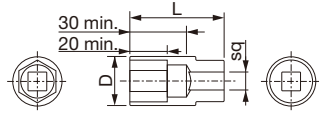

Socket Dimensions (for crimp terminals)

## ■ Magnetic Contactor Installation

Avoid switching a magnetic contactor on the power supply side more frequently than once every 30 minutes. Frequent switching can cause damage to the drive.

## ■ Keypad

[microSD card]

- The SD card supports microSD, and microSD HC with a capacity of up to 32 GB.
- Plug in and remove the microSD card after turning off the power supply for the drive. Do not remove the microSD card or de-energize the keypad when accessing the microSD card. This may cause data loss and failure.
- If there are many files and folders on the SD card or if the free space on the microSD card is low, the SD card may not run properly.

[Connection via USB]

- Use a miniUSB cable. The USB connection between the PC and keypad is not possible while the drive and keypad are connected. First remove the keypad from the drive and then connect with the PC.
- While connected to the USB, it is not possible from a PC to access the files on a microSD card that is inserted.

## ■ Inspection and Maintenance

After shutting off the drive, make sure the CHARGE light has gone out completely before performing any inspection or maintenance. Residual voltage in drive capacitors can cause serious electric shock.

The heatsink can become quite hot during operation, and proper precautions should be taken to prevent burns. When replacing the cooling fan, shut off the power and wait at least 15 minutes to be sure that the heatsink has cooled down.

## ■ Wiring on UL- and cUL-certified drives

When performing wiring work on UL/cUL-certified

drives, wire the drives at their recommended tightening torques using UL/cUL-compliant wires. For drives that require connection with closed-loop crimp terminals, use closed-loop crimp terminals and perform closed-loop crimping work using the crimping tools specified by the terminal manufacturer.

## ■ Replacing an existing model

- Wires used in existing models may be out of connection range. Contact Yaskawa beforehand for the available wire gauges.
- If replacing an existing model with drives with catalog codes of GA70□2211 and lower or 4168 and lower, the wire connection method should be changed. Cut off the crimp terminal and remove the covering to expose the wires. If an uninsulated wire is already connected to it, check the condition of the tip of the wire. After peeling of the dressing as necessary, wire again.

## ■ Transporting the Drive

Never steam clean the drive. During transport, keep the drive from coming into contact with salts, fluorine, bromine and other such harmful chemicals.

## Storage

The drive contains electrolytic capacitors and fine electronic components that undergo chemical changes. Observe the following precautions to help maintain the expected performance life and reliability during long-term storage.

## ■ Storage Location

- Temperature and humidity  
Storage temperatures between -20 to +70°C are allowed when storing the drive for approximately one month. During transport, store and pack the drive so that it is isolated from as much vibration and shock as possible. Store the drive in a location with a relative humidity of 95% or less. Do not store the drive in direct sunlight or where condensation or ice will form.
- Dust and oil mist  
Do not store the drive in dusty locations or locations that are susceptible to oil mist, such as the site of a cement factory or cotton mill.
- Corrosive gas  
Do not store the drive in an area that may contain corrosive gas or in a location like a chemical plant, refinery, or sewage facility.
- Salt-air damage



Do not store the drive in locations that are subject to salt damage, such as near the ocean, and salt damage-designated zones, in particular.

Do not store the drive in adverse environments. Store all drives in storage rooms that are not subjected to adverse environmental elements.

#### ■ Periodic Power Application

Try to apply power to the drive once per year for at least 30 minutes to prevent the capacitors from deteriorating.

When applying power after power has not been applied for more than two years, Yaskawa recommends using a variable power source and gradually increasing the power over a period of 2 to 3 minutes. Apply power for at least 1 hour with no load to age the main circuit electrolytic capacitor.

Wire the drive normally and check for drive faults, overcurrents, motor vibration, speed fluctuations, and other abnormalities during operation after performing the above procedure.

#### ■ Environmental Specifications

The drive must not be used in the above mentioned environments. However, if it is difficult to avoid running the drive in these environments, Yaskawa offers special drives that are resistant to moisture, gas, vibrations, and salt. Contact Yaskawa for details.

Be aware that drives with these specifications do not guarantee complete protection for the environmental conditions indicated.

- Do not run an isolation test of the drive (uncoupled from the load). Contact Yaskawa when running a combinational test with the machine.

## ● Peripheral Devices

#### ■ Installing a Ground Fault Interrupter or an MCCB

- Be sure to install an MCCB or an ELCB that is recommended by Yaskawa at the power supply side of the drive to protect internal circuitry.
- The type of MCCB is selected depending on the power supply power factor (power supply voltage, output frequency, load characteristics, etc.). Sometimes a fairly large MCCB may be required due to the affects of harmonic current on operating characteristics. If you do not use a recommended ELCB, use one fitted for harmonic suppression measures and designed specifically for drives. A malfunction may occur due to

high-frequency leakage current, so the rated current of the ELCB must be 30 mA or higher per drive unit. If a malfunction occurs in an ELCB without any countermeasures, reduce the carrier frequency of the drive, replace the ELCB with one that has countermeasures against high frequency, or use an ELCB which has a rated current of 200 mA or higher per drive unit.

Select an MCCB or an ELCB with a rated capacity greater than the short-circuit current for the power supply. For a fairly large power supply transformer, a fuse can be added to the ELCB or MCCB in order to handle the short-circuit current level.

#### ■ Magnetic Contactor for Input Power

Use a magnetic contactor (MC) to ensure that power to the drive can be completely shut off when necessary. The MC should be wired so that it opens when a fault output terminal is triggered.

Even though an MC is designed to switch to a momentary power loss, frequent MC use can damage other components.

Avoid switching the MC more than once every 30 minutes. The MC will not be activated after a momentary power loss if using the LCD keypad to run the drive. This is because the drive is unable to restart automatically when set for LOCAL.

Although the drive can be stopped by using an MC installed on the power supply side, the drive cannot stop the motor in a controlled fashion, and it will simply coast to stop. If a braking resistor or dynamic braking unit has been installed, be sure to set up a sequence that opens the MC with a thermal protector switch connected to the braking resistor device.

#### ■ Magnetic Contactor for Motor

As a general principle, the user should avoid opening and closing the magnetic contactor during run when the contactor is installed between the motor and the drive. Doing so can cause high peak currents and overcurrent faults. If magnetic contactors are used to bypass the drive by connecting the motor to the power supply directly, make sure to close the bypass only after the drive is stopped and fully disconnected from the motor. The Speed Search function can be used to start a coasting motor.

Use an MC with delayed release if momentary power loss is a concern.

# Application Notes

## Motor Thermal Over Load Relay Installation

Although the drive comes with built in electrothermal protection to prevent damage from overheat, a thermal relay should be connected between the drive and each motor if running several motors from the same drive. For a multi-pole motor or some other type of non-standard motor, Yaskawa recommends using an external thermal relay appropriate for the motor. Be sure to disable the motor protection selection parameter (L1-01 = 0), and set the thermal relay or thermal protection value to 1.1 times the motor rated current listed on the motor nameplate.

When long motor cables and high carrier frequency are used, nuisance tripping of the thermal relay may occur due to increased leakage current. Therefore, reduce the carrier frequency or increase the tripping level of the thermal overload relay.

## Improving the Power Factor

Install a DC reactor, AC reactor, or Power Regenerative Converter D1000 to the drive input side to improve the power factor. The DC reactor is built in for models of catalog codes GA70□2110 and above, GA70□4060 and above.

Refrain from using a capacitor or surge absorber on the output side as a way of improving the power factor, because high-frequency contents on the output side can lead to damage from overheat. This can also lead to problems with overcurrent.

## Radio Frequency Interference

Drive output contains high-frequency contents that can affect the performance of surrounding electronic instruments such as an AM radio. These problems can be prevented by installing a noise filter, as well as by using a properly grounded metal conduit to separate wiring between the drive and motor.

## Wire Gauges and Wiring Distance

Motor torque can suffer as a result of voltage loss across a long cable running between the drive and motor, especially when there is low frequency output. Make sure that a large enough wire gauge is used. The LCD keypad requires an extensional cable for remote operation. If an analog signal is used to operate the drive via the input terminals, make sure that the wire between the analog operator and the drive is no longer than 50 m, and that it is properly separated from the main circuit wiring. Use reinforced circuitry (main circuit and relay sequence circuitry) to prevent inductance

from surrounding devices. To run the drive with a frequency potentiometer via the external terminals, use twisted shielded pair cables and ground the shield.

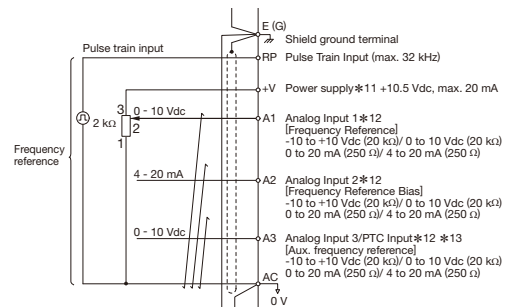

## Counteracting Noise

Because GA700 is designed with PWM control, a low carrier frequency tends to create more motor flux noise than using a higher carrier frequency. Keep the following points in mind when considering how to reduce motor noise:

- Lowering the carrier frequency (C6-02) minimizes the effects of noise.
- A line noise filter can reduce the affects on AM radio frequencies and poor sensor performance. See "Options and Peripheral Devices" on page 38.
- Make sure the distance between signal and power lines is at least 10 cm (up to 30 cm is preferable), and use twisted pair cable to prevent induction noise from the drive power lines.

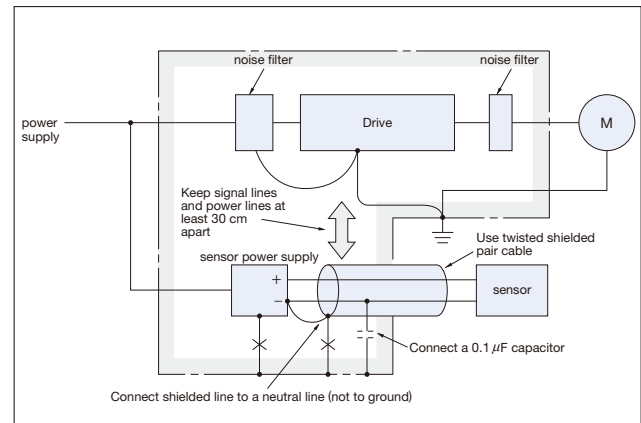

<Provided by JEMA>

## ■ Leakage Current

High-frequency leakage current passes through stray capacitance that exists between the power lines to the drive, ground, and the motor lines. Consider using the following peripheral devices to prevent problems with leakage current.

	Problem	Solution
Ground Leakage Current	MCCB is mistakenly triggered	<ul style="list-style-type: none"> <li>Lower the carrier frequency set to parameter C6-02.</li> <li>Try using a component designed to minimize harmonic distortion for the MCCB such as the NV series by Mitsubishi.</li> </ul>
Current Leakage Between Lines	Thermal relay connected to the external terminals is mistakenly triggered by harmonics in the leakage current	<ul style="list-style-type: none"> <li>Lower the carrier frequency set to parameter C6-02.</li> <li>Use the drive's built-in thermal motor protection function.</li> </ul>

The following table shows the guidelines for the set value of the carrier frequency relative to the wiring distance between the drive and the motor when using V/f control.

Wiring Distance*	50 m or less	100 m or less	100 m or more
C6-02: Carrier Frequency Selection	1 to A (15 kHz or less)	1, 2, 7 to A (5 kHz or less)	1, 7 to A (2 kHz or less)

\*: When a single drive is used to run multiple motors, the length of the motor cable should be calculated as the total distance between the drive and each motor.

When the wiring distance exceeds 100 m, use the drive observing the following conditions.

- Select V/f control mode (A1-02=0)
- To start a coasting motor
  - Use the current detection type (b3-24=0) when using the speed search function, or
  - Set the DC injection braking time at start (b2-03=0.01 to 10.00 sec) to stop a coasting motor and restart it.

More than one synchronous motor cannot be connected to a single drive. The maximum wiring distance between the drive and the synchronous motor must be 100 m.

## ● Notes on Motor Operation

### ■ Motor Bearing Life

In applications involving constant speed over long periods, such as fans, pumps, extruders, and textile machinery, the life of the motor bearing may be shortened. This is called bearing electrolytic corrosion. The installation of a zero-phase reactor between the drive and motor, and the utilization of a motor with insulated bearings are effective countermeasures. Details can be found in the technical documentation. Contact your Yaskawa or nearest sales representative for more information.

### Using a Standard Motor

#### ■ Low Speed Range

There is a greater amount of loss when operating a motor using an drive than when running directly from line power. With a drive, the motor can become quite hot due to the poor ability to cool the motor at low speeds. The load torque should be reduced accordingly at low speeds. The figure above shows the allowable load characteristics for a Yaskawa standard motor. A motor designed specifically for operation with a drive should be used when 100% continuous torque is needed at low speeds.

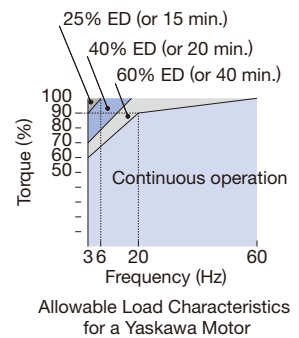

#### ■ Insulation Tolerance

Consider voltage tolerance levels and insulation in applications with an input voltage of over 440 V or particularly long wiring distances. Use a drive motor that has been equipped with isolation countermeasures.

#### ■ High Speed Operation

Problems may occur with the motor bearings and dynamic balance in applications operating at over 60 Hz. Contact Yaskawa for consultation.

#### ■ Torque Characteristics

Torque characteristics differ when operating directly from line power. The user should have a full understanding of the load torque characteristics for the application.

# Application Notes

## ■ Vibration and Shock

The motor may generate vibrations in the following circumstances.

### (1) Resonance

Take particular caution when using a variable speed drive for an application that is conventionally run from line power at a constant speed. Shock-absorbing rubber should be installed around the base of the motor and the Jump Frequency selection should be enabled to prevent resonance.

### (2) Any imperfection on a rotating body increases vibration with speed.

Caution should be taken when operating above the motor rated speed.

### (3) Subsynchronous Resonance

Subsynchronous resonance may occur in fans, blowers, turbines, and other applications with high load inertia, as well as in motors with a relatively long shaft. Yaskawa recommends using Closed Loop Vector Control for such applications.

## ■ Audible Noise

Noise created during run varies by the carrier frequency setting. Using a high carrier frequency creates about as much noise as running from line power. Operating above the rated speed (i.e., above 60 Hz), however, can create unpleasant motor noise.

## Using a Highly Efficient Motor

### ■ IE3 Motor

The IE3 motor has superior features compared to the standard IE1 motors. Contact Yaskawa for technical documents.

Refer to "Using a Synchronous Motor" for more information on highly efficient motor using synchronous motors.

## Using a Synchronous Motor

- If using a motor other than the Yaskawa PM motor, contact your Yaskawa or nearest sales representative.
- If the motor must be run using commercial power supply, use an IM motor.
- A single drive is not capable of running multiple synchronous motors at the same time. Use a standard induction motor for such setups.

- When starting in Open Loop Vector Control for PM, the half rotation angle (electrical angle) of the motor may rotate reverse.
- The starting torque varies depending on the control mode and motor being used. Set up the motor with the drive after verifying the starting torque, allowable load characteristics, impact load tolerance, and speed control range. To use the device beyond these ranges, contact a Yaskawa representative or salesperson.
- Even with a braking resistor, braking torque is less than 125% when running between 20% to 100% speed, and falls to less than half the braking torque when running at less than 20% speed in Open Loop Vector Control for PM.
- In Open Loop Vector Control for PM, the allowable load inertia moment is 50 times less than the motor inertia moment. Use Closed Loop Vector Control for PM for applications exceeding this value.
- When using a holding brake in Open Loop Vector Control for PM, release the brake prior to starting the motor. Failure to set the proper timing can result in speed loss. Conveyor, transport, and hoist applications using a holding brake should run an IPM motor in Closed Loop Vector Control for PM. Do not use this for conveyor machines and gravity load applications such as elevators in particular.
- In Open Loop Vector Control, use the Short Circuit Braking function to stop the motor so that the motor coasting at a speed of at least 200 Hz can be started. A specialized braking resistor is required to use the Short Circuit Braking function. Contact a Yaskawa representative or salesperson for more information. Speed Search can be used to restart a coasting motor rotating slower than 200 Hz. If the motor cable is relatively long, however, the motor should instead be stopped using Short Circuit Braking function and then restarted.
  - \*: Short Circuit Braking creates a short-circuit in the motor windings to forcibly stop a coasting motor.
- EZ Open Loop Vector Control is also able to drive SynRM (synchronous reluctance motor). Contact Yaskawa or your nearest sales representative for details.

■ If PG fails using a PM motor with PG and is replaced, maintain the state where the motor can be rotated and perform Z Pulse Offset Tuning (Rotational Auto-Tuning) and PM Rotational Auto-Tuning.

■ If oC (Overcurrent), STPo (Pull-Out Detection) and LSo (LSo Fault) occur when restarting the motor, use search retry and Short Circuit Braking when starting the motor, and adjust accordingly.

## ● Applications with Specialized Motors

### ■ Multi-Pole Motor

Because the rated current will differ from a standard motor, be sure to check the maximum current when selecting a drive. Always stop the motor before switching between the number of motor poles. If a regenerative overvoltage fault occurs or if overcurrent protection is triggered, the motor will coast to stop.

### ■ Submersible Motor

Because motor rated current is greater than a standard motor, select the drive capacity accordingly. Be sure to use a large enough motor cable to avoid decreasing the maximum torque level on account of voltage drop caused by a long motor cable.

### ■ Explosion-Proof Motor

Both the motor and drive need to be tested together to be certified as explosion-proof. The drive is not for explosion proof areas.

An explosion-proof pulse generators (PG) is used for an explosion-proof with voltage tolerance. Use a specially designed pulse coupler between the drive and the PG when wiring.

### ■ Geared Motor

Continuous operation specifications differ by the manufacturer of the lubricant. Due to potential problems of gear damage when operating at low speeds, be sure to select the proper lubricant. Consult with the manufacturer for applications that require frequencies in excess of the rated frequency.

### ■ Single-Phase Motor

Variable speed drives are not designed for operating single phase motors. Using a capacitor to start the motor causes high-frequency current to flow into the capacitors, potentially causing damage. A split-phase start or a repulsion start can end up burning out the starter coils because the internal centrifugal switch is not activated. GA700 is for use only with 3-phase motors.

### ■ Motor with Brake

Caution should be taken when using a drive to operate a motor with a built-in holding brake. If the brake is connected to the output side of the drive, it may not release at start due to low voltage levels. A separate power supply should be installed for the motor brake. Motors with a built-in brake tend to generate a fair amount of noise when running at low speeds.

## Power Driven Machinery

Continuous operation at low speeds wears on the lubricating material used in gear box type systems to accelerate and decelerate power driven machinery. Note also that operation at a frequency exceeding the rated frequency can cause problems with the power transmission mechanism, including audible noise, performance life, and durability due to centrifugal force.

# MEMO

# Global Service Network



Region	Service Area	Service Location	Service Agency	Telephone/Fax
North America	U.S.A.	Chicago (HQ) Los Angeles San Francisco New Jersey Boston Ohio North Carolina	① YASKAWA AMERICA INC.	Headquarters ☎ +1-847-887-7000 FAX +1-847-887-7370
	Mexico	Mexico City	② PILLAR MEXICANA. S.A. DE C.V.	☎ +52-555-660-5553 FAX +52-555-651-5573
South America	Brazil	São Paulo	③ YASKAWA ELÉTRICO DO BRASIL LTDA.	☎ +55-11-3585-1100 FAX +55-11-3585-1187
	Colombia	Bogota	④ VARIADORES LTD.A.	☎ +57-1-795-8250
Europe	Europe, South Africa	Frankfurt	⑤ YASKAWA EUROPE GmbH	☎ +49-6196-569-300 FAX +49-6196-569-398
Asia	Japan	Tokyo, offices nationwide	⑥ YASKAWA ELECTRIC CORPORATION (Manufacturing, sales)	☎ +81-3-5402-4502 FAX +81-3-5402-4580
			⑦ YASKAWA ELECTRIC ENGINEERING CORPORATION (After-sales service)	☎ +81-3-4533-0928 FAX +81-4-2931-1830
	South Korea	Seoul	⑧ YASKAWA ELECTRIC KOREA CORPORATION (Sales)	☎ +82-2-784-7844 FAX +82-2-784-8495
			⑨ YASKAWA ENGINEERING KOREA CORPORATION (After-sales service)	☎ +82-2-3775-0337 FAX +82-2-3775-0338
	China	Beijing, Guangzhou, Shanghai	⑩ YASKAWA ELECTRIC (CHINA) CO., LTD.	☎ +86-21-5385-2200 FAX +86-21-5385-3299
	Taiwan	Taipei	⑪ YASKAWA ELECTRIC TAIWAN CORPORATION	☎ +886-2-8913-1333 FAX +886-2-8913-1513
	Singapore	Singapore	⑫ YASKAWA ELECTRIC (SINGAPORE) PTE. LTD.	☎ +65-6282-3003 FAX +65-6289-3003
	Thailand	Bangkok	⑬ YASKAWA ELECTRIC (THAILAND) CO., LTD.	☎ +66-2-017-0099 FAX +66-2-017-0090
	Vietnam	Ho Chi Minh	⑭ YASKAWA ELECTRIC VIETNAM CO., LTD.	☎ +84-8-3822-8680 FAX +84-8-3822-8780
		Hanoi		☎ +84-4-3634-3953 FAX +84-4-3654-3954
India	Bangalore	⑮ YASKAWA INDIA PRIVATE LIMITED	☎ +91-80-4244-1900 FAX +91-80-4244-1901	
Indonesia	Jakarta	⑯ PT. YASKAWA ELECTRIC INDONESIA	☎ +62-21-2982-6470 FAX +62-21-2982-6471	
Oceania	Australia	Contact to service agency in U.S.A. (①).		

# GA700

**DRIVE CENTER (INVERTER PLANT)**

2-13-1, Nishimiyaichi, Yukuhashi, Fukuoka, 824-8511, Japan  
Phone +81-930-25-2548 Fax +81-930-25-3431  
<http://www.yaskawa.co.jp>

**YASKAWA ELECTRIC CORPORATION**

New Pier Takeshiba South Tower, 1-16-1, Kaigan, Minatoku, Tokyo, 105-6891, Japan  
Phone +81-3-5402-4502 Fax +81-3-5402-4580  
<http://www.yaskawa.co.jp>

**YASKAWA AMERICA, INC.**

2121, Norman Drive South, Waukegan, IL 60085, U.S.A.  
Phone +1-800-YASKAWA (927-5292) or +1-847-887-7000 Fax +1-847-887-7310  
<http://www.yaskawa.com>

**YASKAWA ELÉTRICO DO BRASIL LTDA.**

777, Avenida Piraporinha, Diadema, São Paulo, 09950-000, Brasil  
Phone +55-11-3585-1100 Fax +55-11-3585-1187  
<http://www.yaskawa.com.br>

**YASKAWA EUROPE GmbH**

185, Hauptstraße, Eschborn, 65760, Germany  
Phone +49-6196-569-300 Fax +49-6196-569-398  
<http://www.yaskawa.eu.com>

**YASKAWA ELECTRIC KOREA CORPORATION**

35F, Three IFC, 10 Gukjegeumyung-ro, Yeongdeungpo-gu, Seoul, 07326, Korea  
Phone +82-2-784-7844 Fax +82-2-784-8495  
<http://www.yaskawa.co.kr>

**YASKAWA ELECTRIC (SINGAPORE) PTE. LTD.**

151, Lorong Chuan, #04-02A, New Tech Park 556741, Singapore  
Phone +65-6282-3003 Fax +65-6289-3003  
<http://www.yaskawa.com.sg>

**YASKAWA ELECTRIC (THAILAND) CO., LTD.**

59, 1st-5th Floor, Flourish Building, Soi Ratchadapisek 18, Ratchadapisek Road, Huaykwang, Bangkok 10310, Thailand  
Phone: +66-2-017-0099 Fax: +66-2-017-0799  
<http://www.yaskawa.co.th>

**PT. YASKAWA ELECTRIC INDONESIA**

Secure Building-Gedung B Lantai Dasar & Lantai 1 Jl. Raya Protokol Halim Perdanakusuma, Jakarta 13610, Indonesia  
Phone +62-21-2982-6470 Fax +62-21-2982-6471  
<http://www.yaskawa.co.id/>

**YASKAWA ELETRIC VIETNAM CO., LTD HO CHI MINH OFFICE**

Suite 1904A, 19th Floor Centec Tower, 72-74 Nguyen Thi Minh Khai Street, Ward 6, District 3, Ho Chi Minh City, Vietnam  
Phone +84-8-3822-8680 Fax +84-8-3822-8780

**YASKAWA ELETRIC VIETNAM CO., LTD HA NOI OFFICE**

2nd Floor, Somerset Hoa Binh Hanoi, No. 106, Hoang Quoc Viet Street, Cau Giay District, Hanoi, Vietnam  
Phone +84-4-3634-3953 Fax +84-4-3634-3954

**YASKAWA ELECTRIC (CHINA) CO., LTD.**

22F, One Corporate Avenue, No.222, Hubin Road, Shanghai, 200021, China  
Phone +86-21-5385-2200 Fax +86-21-5385-3299  
<http://www.yaskawa.com.cn>

**YASKAWA ELECTRIC (CHINA) CO., LTD. BEIJING OFFICE**

Room 1011, Tower W3 Oriental Plaza, No.1 East Chang An Ave.,  
Dong Cheng District, Beijing, 100738, China  
Phone +86-10-8518-4086 Fax +86-10-8518-4082

**YASKAWA ELECTRIC TAIWAN CORPORATION**

9F, 16, Nanking E. Rd., Sec. 3, Taipei, 104, Taiwan  
Phone +886-2-2502-5003 Fax +886-2-2505-1280  
<http://www.yaskawa-taiwan.com.tw>

**YASKAWA INDIA PRIVATE LIMITED**

#17/A, Electronics City, Hosur Road, Bangalore, 560 100 (Karnataka), India  
Phone +91-80-4244-1900 Fax +91-80-4244-1901  
<http://www.yaskawaindia.in>

**YASKAWA****YASKAWA ELECTRIC CORPORATION**

In the event that the end user of this product is to be the military and said product is to be employed in any weapons systems or the manufacture thereof, the export will fall under the relevant regulations as stipulated in the Foreign Exchange and Foreign Trade Regulations. Therefore, be sure to follow all procedures and submit all relevant documentation according to any and all rules, regulations and laws that may apply. Specifications are subject to change without notice for ongoing product modifications and improvements.

© 2016-2017 YASKAWA ELECTRIC CORPORATION

LITERATURE NO. KAEP C710617 00C <2>-0

Published in Japan April 2017  
16-8-23