

A1000 to GA700 Product Replacement Guide

TABLE OF CONTENTS

	Page
1. Applicable Models	2
2. Replacement Checklist	2
3. Terminal Compatibility Chart	4
3-1. Main Circuit Terminals	4
3-2. Control Circuit Terminals, Signal Levels	6
3-3. Communication Circuit Terminals	9
3-4. Terminal Sizes and Wire Gauge	10
4. Dimensions and Installation Adapters	16
4-1. Exterior and Mounting Dimensions	16
4-2. UL Type 1 Kit	18
4-3. Adapters and Attachments to Match Mounting Dimensions	19
4-4. Braking Resistor Installation Attachment	20
5. Parameter Transition Guide	21
5-1. Parameter Setting Transition Instructions	21
5-2. Checking Modified Parameters with A1000 Verify Menu	21
5-3. Parameter Compatibility Table	22
6. Carrier Frequency and Rated Current Derating	24
Matching Keypad and Operator	28
Revision History	29

This document covers the difference between A1000 and GA700 for a successful retrofit. Be sure to also check any manuals for peripheral device used.

1. Applicable Drive Models

Previous Model: A1000
Models: CIMR-AA□A□□□□

New Model: GA700
Catalog code: GA70A□□□□

Capacities: 200 V class: 0.4 kW - 11 kW Heavy Duty (HD) (*Not yet available for 15 kW - 110 kW)
0.75 kW - 15 kW Normal Duty (ND) (*Not yet available for 18.5 kW - 110 kW)
400 V Class: 0.4 kW - 15 kW Heavy Duty (HD) (*Not yet available for 18.5 kW - 560 kW)
0.75 kW - 18.5 kW Normal Duty (ND) (*Not yet available for 22 kW - 630 kW)

2. Replacement Checklist

Type	Item	Checkpoints	Checked
Hardware	Drive	<p><u>Verifying Installation Area of the Drive</u> Dimensions (W, H, D) and installation holes differ between A1000 and GA700. GA700 has a larger depth. Ensure the sufficient space for installation. More depth is required if using the installation attachment to match the same mounting holes used for A1000.</p>	
		<p><u>Verifying the Installation Location of the Keypad (Digital Operator)</u> * Main device keypad (digital operator) Keypad dimensions and the mounting position differ between A1000 and GA700. If the control panel has been cut-out to accompany the previous drive, then either the panel cut out dimensions or the drive installation position should be changed. * Remote keypad (digital operator) Previous remote keypads (the A1000 remote digital operator) are not compatible with the newer models, so users will need to purchase a new keypad and to change the panel cut-out dimension. The keypad panel attachment (operator mounting bracket) for A1000 is not compatible with GA700, so users will also need to purchase the new attachment.</p>	
		<p><u>Verifying Specialized Specifications</u> Check all specifications that may be unique to your drive, including the nameplate, modifications and special coating. This information can be found on the original invoice and product description.</p>	
Hardware	Main Circuit	<p><u>Verifying Main Circuit Lines (Including Ground)</u> Location of the main circuit and its wiring configuration differ between A1000 and GA700. If there is no room for the main circuit wiring, then rearrange the wiring, or use longer wires.</p>	
		<p><u>Verifying Main Circuit Terminal Specifications</u> GA700 uses European terminals in the main circuit, so closed-loop crimp terminals cannot be connected. Remove crimp terminals and prepare the wire ends. Terminal shapes and sizes differ between A1000 and GA700. Refer to Section 3-1 for terminal input/output specifications.</p>	
Hardware	Control Circuit	<p><u>Verifying Control Circuit Lines</u> Location of the control circuit terminal block and its wiring configuration differ between A1000 and GA700. If there is no room for the control circuit wiring, then rearrange the wiring, or use longer wires.</p>	
		<p><u>Verifying Control Circuit Terminal Blocks and Specifications</u> GA700 uses European terminals in the control circuit, so closed-loop crimp terminals cannot be connected. Remove crimp terminals and prepare the wire ends. The number of terminals, terminal shapes, and terminal sizes differ between A1000 and GA700. Refer to Section 3-2 for terminal I/O specifications.</p>	

Type	Item	Checkpoints	Checked
Software	Software	<p><u>Verifying Custom Software</u> Check if the software currently being used is Yaskawa's standard software. Contact Yaskawa and confirm the software number if it is not clear whether the software is standard or not.</p>	
	Parameters	<p><u>Verifying Parameter Settings</u> Parameters do not all match between A1000 and GA700. After checking the parameters in the drive currently being used, follow the procedure in Section 5 to set the appropriate parameters to match the new drive. Contact Yaskawa if there are any parameters not covered in Section 5.</p> <p>The support tool "Drive Wizard" for GA700 offers a Drive Replacement function for converting parameter settings to GA700. (Available soon) DriveWizard is not the same as DriveWizard Plus.</p>	
Options Others	Options Card	<p><u>Verifying Option Cards</u> Option cards for A1000 are compatible with GA700. Note that the following option software versions and later versions with larger software numbers are compatible with GA700.</p> <ul style="list-style-type: none"> - DeviceNet SI-N3 => PRG: 1114 - MECHATROLINK-II SI-T3 => PRG: 6108 - MECHATROLINK-III SI-ET3 => PRG: 6202 	
	Peripherals	<p><u>Braking Resistor</u> Check if the drive currently being used has a braking resistor. If there is a braking resistor (ERF type) installed to the backside of the drive, then note the following: (1) The braking resistor installation attachment used for A1000 is not compatible with GA700. Although the overall dimensions are the same, GA700 requires a special attachment. (Refer to Section 4-4 for how to order the attachment and for its installation dimensions.) Standard vibration tolerance specifications may not be guaranteed if an installation attachment is used. Yaskawa recommends installing the braking resistor in a separate location if the drive is used in an area with a high degree of vibration. (2) If planning to use the same ERF-type braking resistor installed to A1000 in the new GA700 drive and the cable is too short, replace the cable with a longer one only if the wire specifications are the same. Ensure that the cable extension is properly insulated.</p> <p><u>Braking Units</u> The braking unit can be transferred to GA700 as-is without making any changes. If using a braking unit with catalog code GA70A2056 or below (200 V class), or catalog code GA70A4038 or below (400 V class), then set L8-55 = 0 [Internal Braking Transistor Protection = Disabled]. Note: If using a drive with a built-in braking transistor (catalog code GA70A2056 or below for 200 V class drives, or catalog code GA70A4038 or below for 400 V class drives), then connect the drive terminal B1 to the positive terminal of the braking unit, and connect the negative terminal of the drive and the negative terminal of the braking unit. Terminal B2 is not used in GA700.</p> <p><u>AC or DC Reactor</u> The AC or DC reactor can be transferred to GA700 as-is without making any changes.</p> <p><u>Noise Filter</u> The noise filter can be transferred to GA700 as-is without making any changes.</p> <p><u>Fuse</u> The fuses can be transferred to GA700 as-is without making any changes.</p>	

- Refer to the instruction manual included with the product for replacing the drive.
- To request a catalog, user manual, pricing, or shipping dates, contact a Yaskawa sales representative.
- For any technical questions, contact Yaskawa Call Center (toll free: 0120-114616).

3. Terminal Compatibility Chart

Some terminal sizes and shapes differ between A1000 and GA700. (Refer to the table in Section 3-4)

3-1. Main Circuit Terminals

- Terminal functions are the same in A1000 and GA700 although terminal shapes are different.

Main circuit terminals		Notes
A1000	GA700	
R/L1	R/L1	Main circuit power supply input
S/L2	S/L2	
T/L3	T/L3	
U/T1	U/T1	Drive output
V/T2	V/T2	
W/T3	W/T3	
B1	B1	Terminal connections for braking resistor or braking resistor units
B2	B2	
+1	+1	DC reactor, DC power input (+)
+2	+2	DC reactor
-	-	DC power supply input: (-), Braking units: (-)
⊕ (x 2)	⊕ (x 2)	Grounding 200 V class: D class grounding (ground to 100 Ω or less) 400 V class: C class grounding (ground to 10 Ω or less)

Note: For models with a built-in braking transistor (200 V class, catalog code: GA70A2056 or below, or 400 V class, catalog code GA70A4038 or below,) that also have a braking unit, connect terminal B1 to the positive terminal on the braking unit, and the negative terminal on the drive to the negative terminal on the braking unit. Terminal B2 is not used in GA700.

- A1000 Main Circuit Terminal Configuration

- GA700 Main Circuit Terminal Configuration

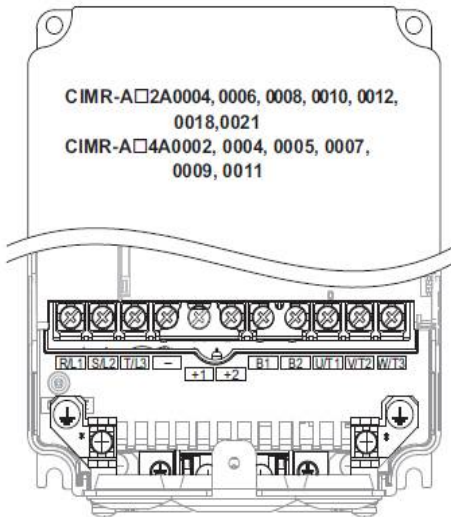

=>

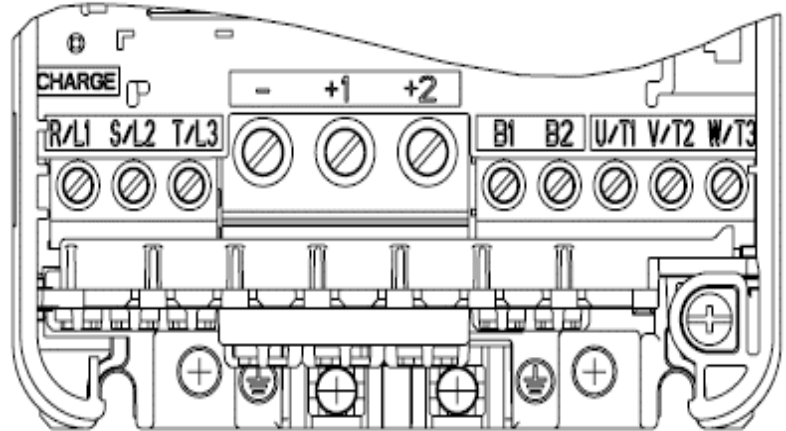
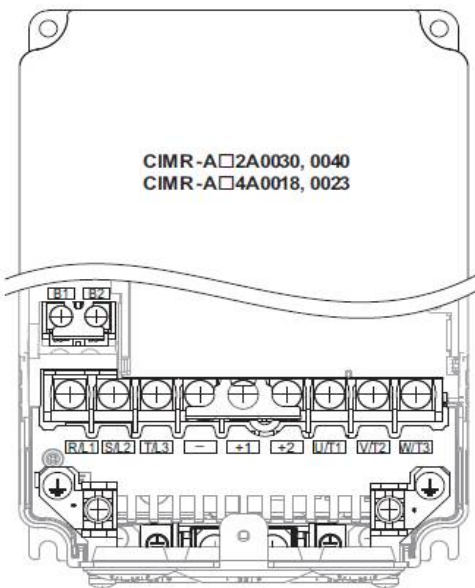

- A1000 Main Circuit Terminal Configuration

- GA700 Main Circuit Terminal Configuration

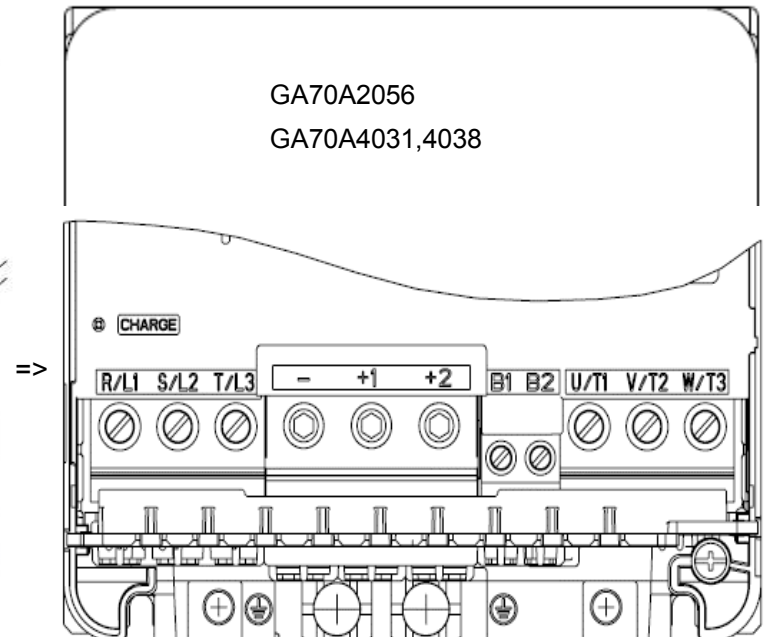
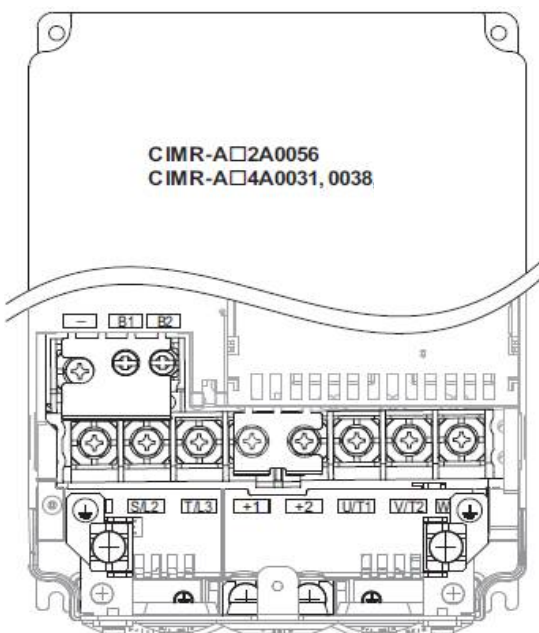

=>

3-2. Control Circuit Terminals, Signal Levels

- Terminal function defaults differences between A1000 and GA700 are listed in the table below.

Control circuit terminals		Name	Signal Level	
A1000	GA700		A1000	GA700
S1	S1	Multi-function input 1 (Closed: Forward run, Open: Stop)	Photocoupler 24 Vdc, 8 mA	Photocoupler 24 Vdc, 6 mA
S2	S2	Multi-function input 2 (Closed: Reverse run, Open: Stop)		
S3	S3	Terminal input 3 (External fault (N.O.))		
S4	S4	Multi-function input 4 (Fault reset)		
S5	S5	Multi-function input 5 (Multi-step speed reference 1)		
S6	S6	Multi-function input 6 (Multi-step speed reference 2)		
S7	S7	Multi-function input 7 (Jog reference)		
S8	S8	Multi-function input 8 (Baseblock command (N.O.))		
SC *1	SN	Multi-function input common	Photocoupler 24 Vdc, 8 mA	MFDI power supply, 24V (max. 150 mA) Note: Do not install a jumper between terminals SP and SN.
	SC	Digital input power supply 0 V		
	SP	Digital input power supply +24 Vdc		
RP	RP	Multi-function pulse train input	Response frequency 0.5 - 32 kHz (3 kΩ)	Response frequency 0.1 - 32 kHz (3 kΩ)
+V	+V	Power supply for analog inputs	+10.5 V (allowable current 20 mA max.)	
-V	-V	Power supply for analog inputs	-10.5V (allowable current 20 mA max.)	
A1	A1	Multi-function analog input 1	0 - +10 V (20 kΩ) 0+/-10 V	0 - +10 Vdc (20 kΩ) 0+/-10 V 4 - 20 mA (250 Ω) 0 - 20 mA (250 Ω)
A2	A2	Multi-function analog input 2	0 - +10 Vdc (20 kΩ) 0+/-10 V 4 - 20 mA (250 Ω) 0 - 20 mA (250 Ω)	
A3	A3	Multi-function analog input 3	0 - +10 V (20 kΩ) 0+/-10 V	
AC	AC	Frequency reference common	0 V	
E (G)	E (G)	Ground for shielded lines and option cards	-	
H1	H1	Safe Disable input 1	24 Vdc, 8 mA Closed: Normal operation Open: Coasting motor Internal impedance 3.3 kΩ OFF time of at least 1 ms	24 Vdc, 6 mA Closed: Normal operation Open: Coasting motor Internal impedance 4.7 kΩ OFF time of at least 2 ms
H2	H2	Safe Disable input 2		
HC	HC	Safe Disable function common	Safe Disable function common	Safe Disable function common Note: Do not jumper or short terminals HC and SN.
DM+ *2		Safety monitor output	+48 Vdc 50 mA max.	Connect to Multi-function digital output, Multi-function photocoupler output
DM- *2		Safety monitor output		

Control circuit terminals		Name	Signal Level	
A1000	GA700		A1000	GA700
MA	MA	N.O. output (Fault)	Fault relay output 30 Vdc 10 mA - 1A 250 Vac 10 mA - 1A	
MB	MB	N.C. output (Fault)		
MC	MC	Fault output common		
M1	M1	Multi-function digital output (During run)	Multi-function digital output 30 Vdc 10 mA - 1A 250 Vac 10 mA - 1A	
M2	M2			
	M3	Multi-function digital output (Zero speed)		
	M4			
P1	P1	Photocoupler output 1 (Zero speed) Note: Default function differs between A1000 and GA700. A1000: Zero Speed Control GA700: Speed Agree 1	Multi-function photocoupler output +48 Vdc 50 mA max.	
	C1 *3	To change the function assigned to the terminal in GA700 to Zero Speed Control, change the parameter setting of GA700 so that H2-03 = 1 (default setting is H2-03 = 2).		
	P2	P2		
	C2 *3	To change the function assigned to the terminal in GA700 to Speed Agree 1, change the parameter setting of GA700 so that H2-04 = 2 (default setting is H2-04 = F).		
	PC *3		Photocoupler output common	
MP	MP	Pulse train output (Output frequency)	32 kHz (2.2 kΩ) max.	
FM	FM	Analog monitor output 1 (Output frequency)	-10 - +10 Vdc (max. current 2 mA) Resolution: 1/1000	-10 - +10 Vdc (max. current 2 mA) 4 - 20 mA Select voltage or current output.
AM	AM	Analog monitor output 2 (Output current)		
AC	AC	Monitor common	0 V	

Terminal connections and drive settings

- *1. Use the connection diagram on the following page when transferring the SC terminal wiring from A1000 to GA700.
- *2. Transfer wiring from the DM+ and DM- terminals on A1000 to terminals M1 and M2 or to M3 and M4 on GA700.
Or, transfer wiring to the P1 and C1 terminals, or to the P2 and C2 terminals on GA700.
 - Set H2-01 = 21 when using the M1 and M2 terminals.
 - Set H2-02 = 21 when using the M3 and M4 terminals.
 - Set H2-03 = 21 when using the P1 and C1 terminals.
 - Set H2-04 = 21 when using the P2 and C2 terminals.
- *3. Transfer wiring from terminal PC on A1000 to either terminal C1 or C2 on GA700.

Control I/O Connections

◆ Sinking/Sourcing Mode for Digital Inputs

A1000 uses a jumper on the control board to set the sinking/sourcing mode and internal/external power supply. Meanwhile, GA700 uses terminals SN, SC, and SP.

Check how the jumper is set in A1000, then make corresponding changes in GA700.

The default setting in GA700 is for sinking mode and an internal power supply.

Note: Do not short terminals SP and SN.

Mode/Power supply	A1000	GA700
Sinking Mode (NPN) Internal power supply		
Sourcing Mode (PNP) Internal power supply		
Sinking Mode (NPN) External power supply		
Sourcing Mode (PNP) External power supply		

- A1000 Control Circuit Terminal Configuration

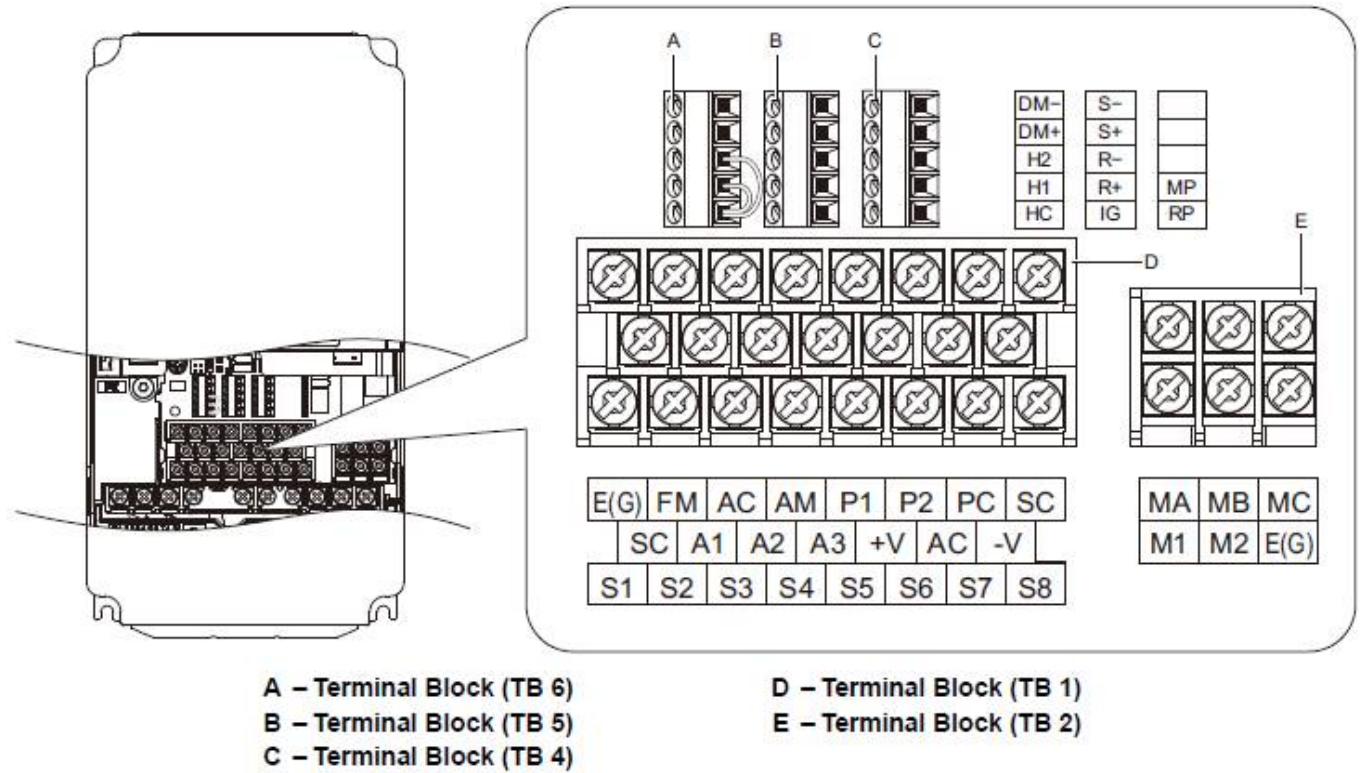

- GA700 Control Circuit Terminal Configuration

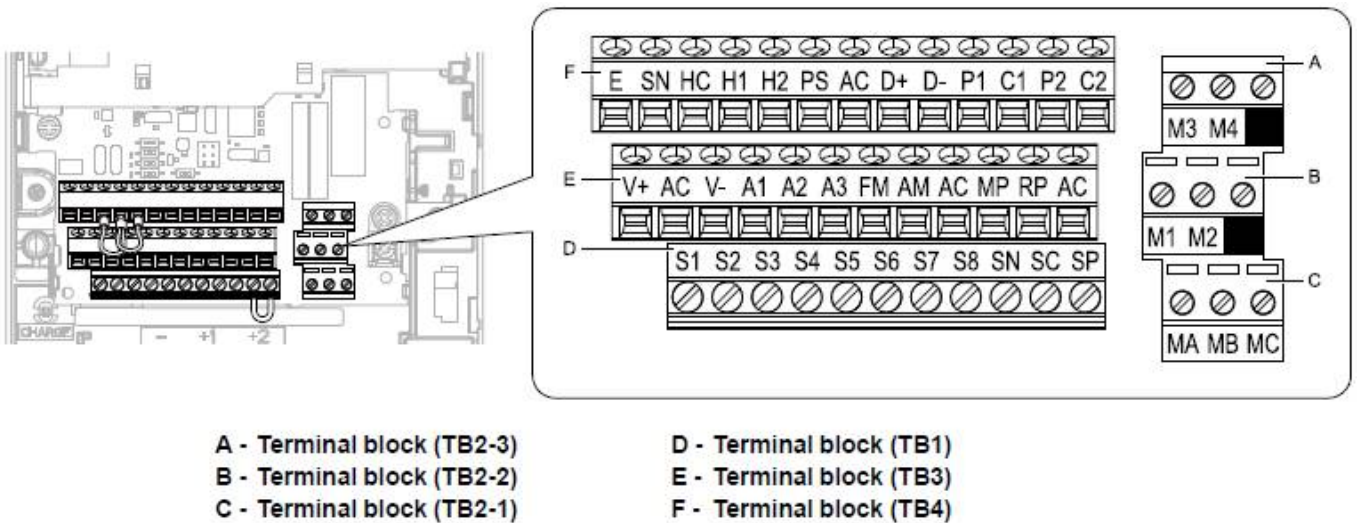

3-3. Serial Communication Terminals

Comm. terminal		Name	Signal Level	
A1000	GA700		A1000	GA700
R+	D+	A1000: Communications input (+) GA700: Communications input/output (+)	Differential input Photocoupler insulation Use an RS-485 or RS-422 cable to connect the drive.	Differential input Photocoupler insulation Use an RS-485 cable to connect the drive.
R-	D-	A1000: Communications input (-) GA700: Communications input/output (-)		
S+	D+	A1000: Communications output (+) GA700: Communications input/output (+)		
S-	D-	A1000: Communications output (-) GA700: Communications input/output (-)		
IG	AC	Shield ground	0 V	0 V

3-4. Terminal Sizes and Wire Gauge

Main Circuit Terminal Sizes and Wire Gauge

200 V Class

⓪ Indicates ground terminal

Model	Drive Capacity A1000: Model GA700: Catalog code	Terminal Symbol	Applicable Gauge mm ²	Terminal Screw		Tightening Torque N·m
				Size	Shape	
A1000	CIMR-AA2A0004 CIMR-AA2A0006 CIMR-AA2A0008 CIMR-AA2A0010 CIMR-AA2A0012 CIMR-AA2A0018	R/L1,S/L2,T/L3	2 - 5.5	M4	Panhead (+)	1.2 - 1.5
		U/T1,V/T2,W/T3	2 - 5.5			
		-,+1,+2	2 - 5.5			
		B1,B2	2 - 5.5			
		⓪	2 - 5.5			
GA700	GA70A2004 GA70A2006 GA70A2008 GA70A2010 GA70A2012 GA70A2018	R/L1,S/L2,T/L3	2 - 14	M4	Slot (-)	1.5 - 1.7
		U/T1,V/T2,W/T3	2 - 14	M5		2.3 - 2.5
		-,+1,+2	2 - 22			1.5 - 1.7
		B1,B2	2 - 5.5			M4
		⓪	2 - 5.5	M4		+/- screw
A1000	CIMR-AA2A0021	R/L1,S/L2,T/L3	3.5 - 5.5	M4	Panhead (+)	1.2 - 1.5
		U/T1,V/T2,W/T3	3.5 - 5.5			
		-,+1,+2	3.5 - 5.5			
		B1,B2	2 - 5.5			
		⓪	3.5 - 5.5			
GA700	GA70A2021	R/L1,S/L2,T/L3	2 - 14	M4	Slot (-)	1.5 - 1.7
		U/T1,V/T2,W/T3	2 - 14	M5		2.3 - 2.5
		-,+1,+2	2 - 22			1.5 - 1.7
		B1,B2	2 - 5.5			M4
		⓪	3.5 - 5.5	M4		+/- screw
A1000	CIMR-AA2A0030	R/L1,S/L2,T/L3	5.5 - 14	M4	Panhead (+)	2.1 - 2.3
		U/T1,V/T2,W/T3	5.5 - 14			
		-,+1,+2	5.5 - 14			
		B1,B2	2 - 5.5			
		⓪	5.5 - 8			
GA700	GA70A2030	R/L1,S/L2,T/L3	2 - 14	M4	Slot (-)	1.5 - 1.7
		U/T1,V/T2,W/T3	2 - 14	M5		2.3 - 2.5
		-,+1,+2	2 - 22			1.5 - 1.7
		B1,B2	2 - 5.5			M4
		⓪	5.5 - 8	M5		+/- screw

Model	Drive Capacity A1000: Model GA700: Catalog code	Terminal Symbol	Applicable Gauge mm ²	Terminal Screw		Tightening Torque N·m
				Size	Shape	
A1000	CIMR-AA2A0040	R/L1,S/L2,T/L3	14	M4	Panhead (+)	2.1 - 2.3
		U/T1,V/T2,W/T3	8 - 14			
		-,+1,+2	14			
		B1,B2	3.5 - 5.5	M5	+/- screw	2.0 - 2.5
		≡	5.5 - 8			
GA700	GA70A2042	R/L1,S/L2,T/L3	2 - 14	M4	Slot (-)	1.5 - 1.7
		U/T1,V/T2,W/T3	2 - 14			
		-,+1,+2	2 - 22	M5		2.3 - 2.5
		B1,B2	2 - 5.5	M4		1.5 - 1.7
		≡	5.5 - 8	M5	+/- screw	2.0 - 2.5
A1000	CIMR-AA2A0056	R/L1,S/L2,T/L3	14 - 22	M6	Hexagon bolt (with Phillips screwhead)	5.4 - 6.0
		U/T1,V/T2,W/T3	14 - 22			
		-,+1,+2	14 - 22			
		B1,B2	5.5 - 14	M5	+/- screw	2.7 - 3.0
		≡	8 - 14	M6	+/- screw	5.4 - 6.0
GA700	GA70A2056	R/L1,S/L2,T/L3	8 - 22	M5	Slot (-)	2.3 - 2.5
		U/T1,V/T2,W/T3	5.5 - 14			
		-,+1,+2	8 - 38	M6	Hex socket cap (WAF: 5 mm)	5 - 5.5
		B1,B2	2 - 14	M4	Slot (-)	1.5 - 1.7
		≡	8 - 14	M6	+/- screw	5.4 - 6.0

400 V class

Model	Drive Capacity A1000: Model GA700: Catalog code	Terminal Symbol	Applicable Gauge mm ²	Terminal Screw		Tightening Torque N•m
				Size	Shape	
A1000	CIMR-AA4A0002 CIMR-AA4A0004 CIMR-AA4A0005 CIMR-AA4A0007 CIMR-AA4A0009 CIMR-AA4A0011	R/L1,S/L2,T/L3	2 - 5.5	M4	Panhead (+)	1.2 - 1.5
		U/T1,V/T2,W/T3	2 - 5.5			
		-,+1,+2	2 - 5.5			
		B1,B2	2 - 5.5			
		≡	2 - 5.5			
GA700	GA70A4002 GA70A4004 GA70A4005 GA70A4007 GA70A4009 GA70A4012	R/L1,S/L2,T/L3	2 - 14	M4	Slot (-)	1.5 - 1.7
		U/T1,V/T2,W/T3	2 - 14	M5		2.3 - 2.5
		-,+1,+2	2 - 22			M4
		B1,B2	2 - 5.5	M4		1.2 - 1.5
		≡	2 - 5.5	M4		+/- screw
A1000	CIMR-AA4A0018	R/L1,S/L2,T/L3	2 - 14	M4	Panhead (+)	2.1 - 2.3
		U/T1,V/T2,W/T3	2 - 14			
		-,+1,+2	2 - 14			
		B1,B2	2 - 5.5	M5	+/- screw	2.0 - 2.5
		≡	2 - 5.5			
GA700	GA70A4018	R/L1,S/L2,T/L3	2 - 14	M4	Slot (-)	1.5 - 1.7
		U/T1,V/T2,W/T3	2 - 14	M5		2.3 - 2.5
		-,+1,+2	2 - 22			M4
		B1,B2	2 - 5.5	M4		1.2 - 1.5
		≡	2 - 5.5	M4		+/- screw
A1000	CIMR-AA4A0023	R/L1,S/L2,T/L3	3.5 - 14	M4	Panhead (+)	2.1 - 2.3
		U/T1,V/T2,W/T3	3.5 - 14			
		-,+1,+2	3.5 - 14			
		B1,B2	2 - 5.5	M5	+/- screw	2.0 - 2.5
		≡	3.5 - 5.5			
GA700	GA70A4023	R/L1,S/L2,T/L3	2 - 14	M4	Slot (-)	1.5 - 1.7
		U/T1,V/T2,W/T3	2 - 14	M5		2.3 - 2.5
		-,+1,+2	2 - 22			M4
		B1,B2	2 - 5.5	M5		2.0 - 2.5
		≡	3.5 - 5.5			
A1000	CIMR-AA4A0031	R/L1,S/L2,T/L3	5.5 - 14	M5	Hexagon bolt (with Phillips screwhead)	3.6 - 4.0
		U/T1,V/T2,W/T3	5.5 - 8			
		-,+1,+2	5.5 - 14			
		B1,B2	2 - 8	M5	+/- screw	2.7 - 3.0
		≡	5.5 - 8	M6	+/- screw	5.4 - 6.0

Model	Drive Capacity A1000: Model GA700: Catalog code	Terminal Symbol	Applicable Gauge mm ²	Terminal Screw		Tightening Torque N•m
				Size	Shape	
GA700	GA70A4031	R/L1,S/L2,T/L3	8 - 22	M5	Slot (-)	2.3 - 2.5
		U/T1,V/T2,W/T3	5.5 - 14			
		-,+1,+2	8 - 38	M6	Hex socket cap (WAF: 5 mm)	5 - 5.5
		B1,B2	2 - 14	M4	Slot (-)	1.5 - 1.7
		≡	5.5 - 8	M6	+/- screw	5.4 - 6.0
A1000	CIMR-AA4A0038	R/L1,S/L2,T/L3	14	M5	Hexagon bolt (with Phillips screwhead)	3.6 - 4.0
		U/T1,V/T2,W/T3	8 - 14			
		-,+1,+2	14	M5	+/- screw	2.7 - 3.0
		B1,B2	3.5 - 8	M5	+/- screw	2.7 - 3.0
		≡	5.5 - 14	M6	+/- screw	5.4 - 6.0
GA700	GA70A4038	R/L1,S/L2,T/L3	8 - 22	M5	Slot (-)	2.3 - 2.5
		U/T1,V/T2,W/T3	5.5 - 14			
		-,+1,+2	8 - 38	M6	Hex socket cap (WAF: 5 mm)	5 - 5.5
		B1,B2	2 - 14	M4	Slot (-)	1.5 - 1.7
		≡	5.5 - 14	M6	+/- screw	5.4 - 6.0

Caution when transferring wires to the new drive

Note the following points due to the European terminal block in GA700.

Refer to the GA700 instruction manual for other wiring-related matters.

- The terminal block is not compatible with closed-loop crimp terminals. Remove crimp terminals and prepare the wire ends.
Crimp terminals can be used to connect to the ground terminal.
- Expose the required length of bare wire by stripping back the shielding according to local electrical code.

Bare wire length mm	Terminal Screw		Tightening Torque N·m
	Size	Shape	
10	M4	Slot (-)	1.5 - 1.7
18	M5		2.3 - 2.5
20	M6	Hex socket cap (WAF: 5 mm)	5 - 5.5

- Do not use a wire with bent or crushed conductor.
If a deformed wire is used for connection, cut off the bent end of the wire before using it.
- Do not use solder when connecting stranded wire.
- When using stranded wires, wire the lines so that there are no stray wires in the connection section.
Do not excessively twist the stranded wire.
- Firmly insert the electric wire all the way into the European terminal block.
If the wire covering is removed to the recommended stripped wire length, the covering will fit into the terminal block.
- Tighten screws according to the designated tightening torque listed below.
- A straight tip or hexagonal tool must be used when wiring the European terminal.
- Secure wires in the wiring section so that pressure is not applied to the terminal blocks.
- After connecting the wires, gently pull on the wires to check that they do not pull out.
- Regularly tighten any loose terminal block screws to their specified tightening torques

Wiring Tool (Recommended product)

Screw size	Screw type	Adapter	Recommended Product			
			Bit model	Torque screwdriver model	Torque wrench model	Manufacturer
M4	Slot	Bit	SF-BIT-SL 1,0X4,0-70	TSD-M 3NM (1.2 ~ 3N · m)	-	PHOENIX CONTACT
M5	Slot	Bit	SF-BIT-SL 1,2X6,5-70	TSD-M 3NM (1.2 ~ 3N · m) (≤ 25 mm ² or AWG10)	- *	PHOENIX CONTACT
M6	Hex socket (WAF: 5)	Socket	In Preparation	-	In Preparation	In Preparation
M8	Hex socket (WAF: 6)	Socket	In Preparation	-	In Preparation	In Preparation
M10	Hex socket (WAF: 8)	Socket	In Preparation	-	In Preparation	In Preparation

* Select the appropriate tools from the following that is consistent with the size of the wire used for models GA70□ 2110 and GA70□ 4075 or less.

≤ 25 mm² or AWG 10: Use TSD-M 3NM.

≥ 30 mm² or AWG 8: Use torque wrench.

Provide a torque wrench capable of handling up to 4.5 N·m. Prepare matching bit holder sockets as well.

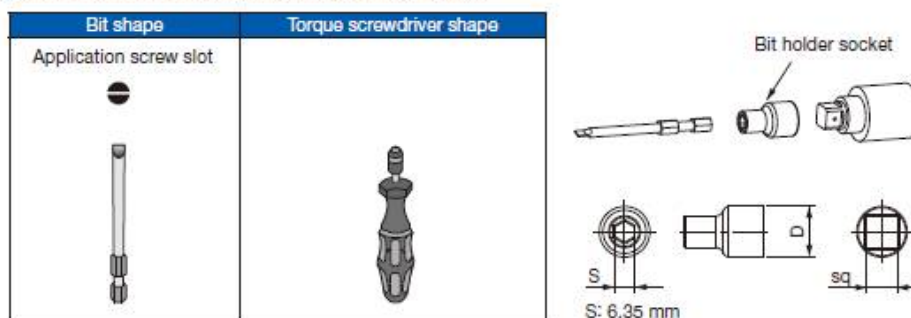

Control Circuit Terminal Sizes and Wire Gauge

Power supply	Model	Capacity	Terminal Symbol	Terminal Screw	Tightening Torque (N•m)	Applicable Gauge (mm ²)	Recommended Gauge (mm ²)
200 V class 400 V class	A1000	All capacities	FM, AC, AM, P1, P2, PC, SC, A1, A2, A3, +V, -V, S1, S2, S3, S4, S5, S6, S7, S8, MA, MB, MC, M1, M2	M3.5	0.8 - 1.0	0.5 - 2.0	0.75
			MP, RP, R+, R-, S+, S-, IG DM+, DM-, H1, H2, HC	M2 Phoenix type	0.22 - 0.25	Stranded wire 0.25 - 1.0 Solid wire 0.25 - 1.5	0.75
			E(G)	M3.5	0.8 - 1.0	0.5 - 2.0	1.25
200 V class 400 V class	GA700	All capacities	FM, AC, AM, P1, C1, P2, C2, SN, SC, SP, A1, A2, A3, +V, -V, S1, S2, S3, S4, S5, S6, S7, S8, MA, MB, MC, M1, M2, M3, M4, MP, RP, D+, D-, H1, H2, HC, PS, E(G)	M3 Phoenix type	0.5 - 0.6	Stranded wire 0.2 - 1.0 Solid wire 0.2 - 1.5	0.75

Terminal Board Wiring Guide

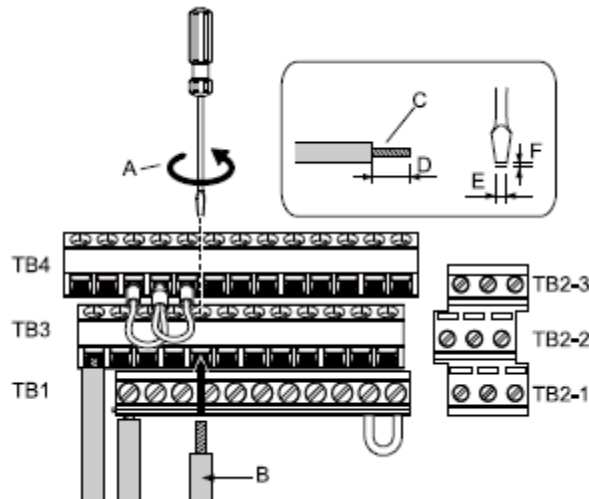

- A: Loosen the screws to insert the wire.
- B: Single wire or stranded wire
- C: Avoid fraying wire strands when stripping insulation from wire.
- D: When crimp ferrules are not used, remove approximately 5.5 mm of the covering at the tip.
- E: Blade width of 2.5 mm or less
- F: Blade depth of 0.4 mm or less

4. Dimensions and Installation Attachments

4-1. Exterior and Mounting Dimensions

Installation holes are not the same in A1000 and GA700.

The standard model A1000 is compliant for a wall-mount enclosure, while the standard model GA700 has an open-chassis design (IP20).

An option is required to install GA700 in a wall-mount enclosure.

A UL Type 1 kit needs to be installed to the open-chassis (IP20) GA700. (Refer to Section 4-2)

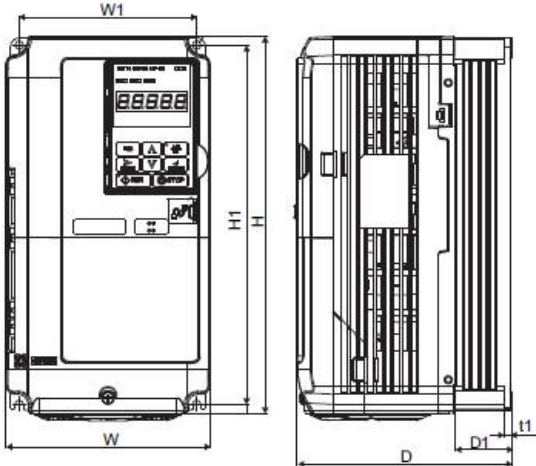
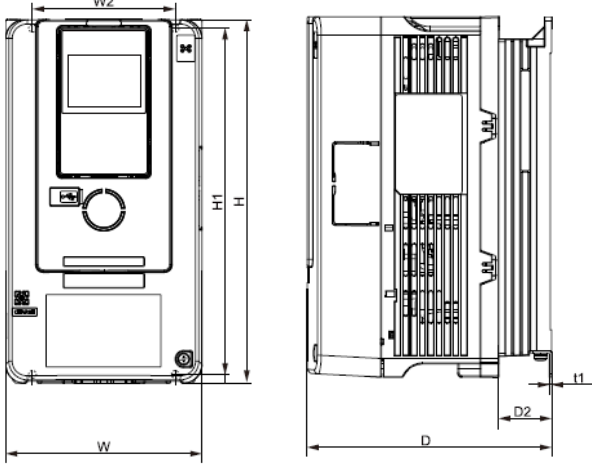
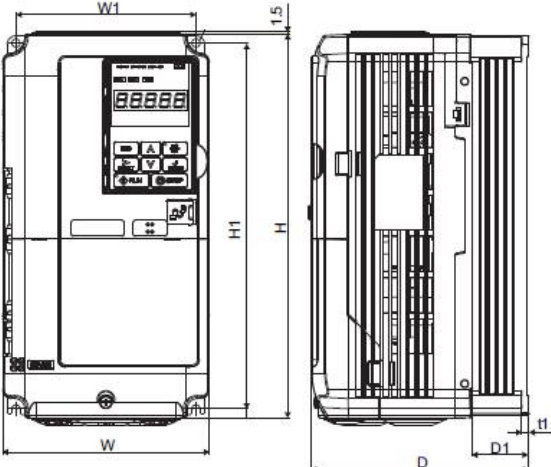
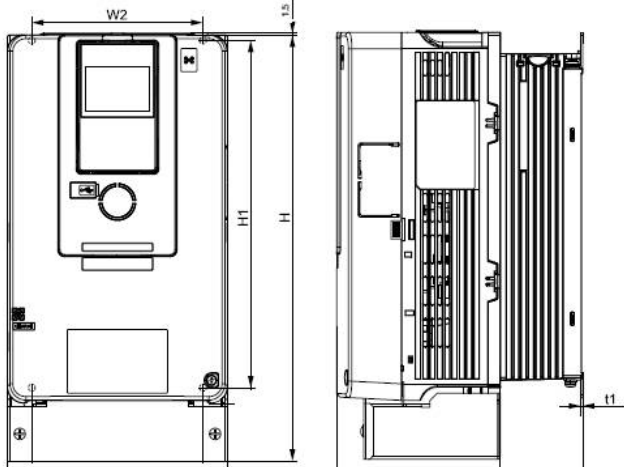
A1000	GA700
<p data-bbox="240 533 783 589">Open Type Enclosure (IP20): Remove the top cover for compliance</p> 	<p data-bbox="857 533 1426 589">Open Type Enclosure (IP20): Standard model is compliant</p> 
<p data-bbox="240 1198 719 1254">Enclosed wall-mounted type (UL Type 1 enclosure): Standard model is compliant</p> 	<p data-bbox="857 1198 1469 1254">Enclosed wall-mounted type (UL Type 1 enclosure): Option required for compliance</p> 

Refer to the table below for exterior and mounting dimensions. Table lists the Heavy Duty (HD) rating.

Open Type Enclosure (IP20)

Voltage class	Capacity (kW)	Dimensions (mm)																	
		A1000							GA700										
		W	H	D	W1	H1	D1	t1	W	H	D	W2	H1	D2	t1				
Three-phase 200 V class	0.4	140	260	147	122	248	38	5	140	260	176	102	248	38	1.6				
	0.75																		
	1.1																		
	1.5			164			55				211			73					
	2.2																		
	3																		
	3.7			167			75				180			300		202	140	284	68
	5.5																		
	7.5																		
11	180	300	187	160	284	75	180	300	202	140	284	68							
Three-phase 400 V class	0.4	140	260	147	122	248	38	5	140	260	176	102	248	38	1.6				
	0.75																		
	1.5																		
	2.2			164			55				211			73					
	3																		
	3.7																		
	5.5			167			75				180			300		202	140	284	68
	7.5																		
	11																		
15	180	300	187	160	284	75	180	300	202	140	284	68							

Enclosed Wall-mounted Type (UL Type 1 Enclosure)

Voltage class	Capacity (kW)	Dimensions (mm)																	
		A1000							GA700										
		W	H	D	W1	H1	D1	t1	W	H	D	W2	H1	D2	t1				
Three-phase 200 V class	0.4	140	260	147	122	248	38	5	140	300	176	102	248	38	1.6				
	0.75																		
	1.1																		
	1.5			164			55				211			73					
	2.2																		
	3																		
	3.7			167			75				180			340		202	140	284	68
	5.5																		
	7.5																		
11	180	300	187	160	284	75	180	340	202	140	284	68							
Three-phase 400 V class	0.4	140	260	147	122	248	38	5	140	300	176	102	248	38	1.6				
	0.75																		
	1.5																		
	2.2			164			55				211			73					
	3																		
	3.7																		
	5.5			167			75				180			340		202	140	284	68
	7.5																		
	11																		
15	180	300	187	160	284	75	180	340	202	140	284	68							

4-2. UL Type 1 Kit

Voltage class	Catalog code	UL Type 1 Kit (catalog code)
Three-phase 200 V class	GA70A2004	100-202-326
	GA70A2006	
	GA70A2008	
	GA70A2010	
	GA70A2012	
	GA70A2018	
	GA70A2021	
	GA70A2030	
	GA70A2042	
	GA70A2056	100-202-327
Three-phase 400 V class	GA70A4002	100-202-326
	GA70A4004	
	GA70A4005	
	GA70A4007	
	GA70A4009	
	GA70A4012	
	GA70A4018	
	GA70A4023	
	GA70A4031	
	GA70A4038	

4-3. Drive Installation Attachment to Match Mounting Dimensions

Dimensions for the open type enclosure drives and enclosed wall-mounted type drives are shown below. GA700 has a larger depth than A1000.

The attachment makes it possible to mount GA700 using the same mounting holes as A1000.

First mount the installation attachment to the holes that A1000 was using, and then mount GA700 to the attachment.

The installation depth increases due to the size of the attachment. The number in parenthesis indicates the dimension when using the attachments.

Open Type Enclosure (IP20)

Table lists the Heavy Duty (HD) rating.

Voltage Class	Capacity (kW)	Dimensions (mm)						Drive Installation Attachment (catalog code)	
		A1000			GA700			Normal installation	External heatsink
		W	H	D	W	H	D		
Three-phase 200 V class	0.4	140	260	147	140	260	176 (189)	100-206-987	Contact Yaskawa.
	0.75								
	1.1								
	1.5			164					
	2.2								
	3								
	3.7	180	300	187	180	300	202 (215)	100-206-988	
	5.5								
	7.5								
11									
Three-phase 400 V class	0.4	140	260	147	140	260	176 (189)	100-206-987	Contact Yaskawa.
	0.75								
	1.1								
	1.5			164					
	2.2								
	3								
	3.7	180	300	187	180	300	202 (215)	100-206-988	
	5.5								
	7.5								
11									
15									

Enclosed Wall-mounted Type (UL Type 1 enclosure)

Table lists the Heavy Duty (HD) rating.

Voltage class	Capacity (kW)	Dimensions (mm)						Drive Installation Attachment (catalog code)	
		A1000			GA700			Normal installation	
		W	H	D	W	H	D		
Three-phase 200 V class	0.4	140	260	147	140	300	176 (189)	100-206-987	
	0.75								
	1.1								
	1.5			164					
	2.2								
	3								
	3.7	180	300	187	180	340	202 (215)	100-206-988	
	5.5								
	7.5								
11									
Three-phase 400 V class	0.4	140	260	147	140	300	176 (189)	100-206-987	
	0.75								
	1.1								
	1.5			164					
	2.2								
	3								
	3.7	180	300	187	180	340	202 (215)	100-206-988	
	5.5								
	7.5								
11									
15									

Note: Standard vibration tolerance specifications may not be guaranteed if an installation attachment is used.

Yaskawa recommends installing the device directly to the drive in an area with a high degree of vibration.

4-4. Braking Resistor Installation Attachment

The braking resistor installation attachment for A1000 is not the same as the one for GA700.

The dimensions are the same, but the braking resistor is installed to a different location.

To use the same braking resistor and braking installation attachment as A1000, the resistor terminal ends need to be prepared first.

The wire length changes depending on how the terminal ends have been prepared.

A1000 200 V class 0.4 kW example

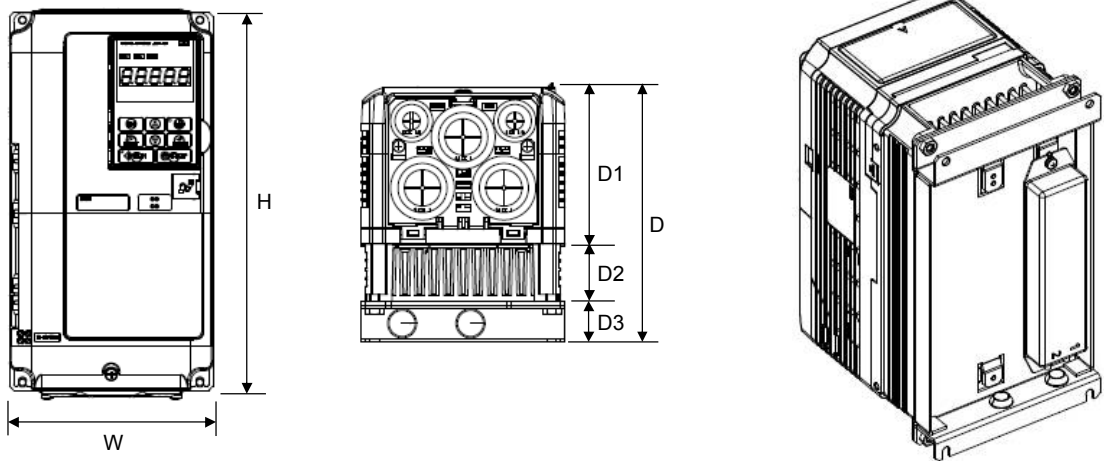

Dimensions after installing the braking resistor installation attachment

Table lists Heavy Duty (HD) ratings.

Voltage Class	Capacity (kW)	Dimensions (mm)												Difference in depth (mm)	Braking resistor installation attachment Model (catalog code)
		A1000						GA700							
		W	H	D1	D2	D3	D	W	H	D1	D2	D3	D		
Three-Phase 200 V Class	0.4	140	260	109	38	28	175	140	260	138	38	28	204	+29	A1000 EZZ020805A (100-048-123)
	0.75													+29	
	1.5													+29	
	2.2													+29	
	3.7													+29	
Three-Phase 400 V Class	0.4	140	260	109	38	28	175	140	260	138	38	28	204	+29	GA700 900-192-126-001 (100-202-333)
	0.75													+29	
	1.5													+29	
	2.2													+29	
	3.7													+29	

Note: Use of the braking resistor installation attachment may void certain vibration and shock requirements.

Yaskawa recommends installing the braking resistor in a separate location if the drive is used in an area with a high degree of vibration.

5. Parameter Transition Guide

5-1. Parameter Setting Transition Instructions

- (1) Prepare a record of all parameters that have been changed from their default settings.
Use the Verify Menu in A1000 if available to check which parameters have been changed.
Yaskawa recommends filling in your setting values to the row marked "User's Setting" of the Parameter Compatibility Table in Section 5-3.
- (2) Change the setting value of A1-01 [Access Level Selection] in GA700 from the default setting 2 to 3 (Expert Level).
- (3) Use the Parameter Compatibility Table in Section 5-3 to transfer any parameter setting changes made in A1000 to GA700.

Note: Parameters for terminals P1 and P2 in A1000 shift by one parameter number in GA700.

- Function selection for terminal P1-PC is H2-02 in A1000, but in GA700, the function selection for terminal P1-C1 is H2-03.
- Function selection for terminal P2-PC is H2-03 in A1000, but in GA700, the function selection for terminal P2-C2 is H2-04.

5-2. Checking Modified Parameters with A1000 Verify Menu

- Energize the A1000.
- Use the Up or Down arrow key to scroll to the Verify Menu (vrFY flashing).
- Push the ENTER key.
- If the display shows "nonE," then no parameters have been changed from their default settings.
- If there are parameters that have been changed from their default settings, then those parameters will flash.
- Press the ENTER key to display the value that the parameter has been set to.
- Make a note of the parameter setting.
- Press the ESC key. The display returns to the flashing parameter.
- Press the Up arrow key.
- If there are other parameters that have been changed from their default settings, then those parameters will flash, and appear in alphabetical order.
- After scrolling through all parameters that have been changed from the default setting, the display returns to the first parameter that was displayed.
- This step is complete once you have made a note of all the parameter setting changes.
- De-energize the A1000.

Note: A1-xx, A2-01 through A2-32 (except for A1-02 [Control Method Selection]), and E5-01 [Motor Code Selection (for PM Motors)] will not appear in the Verify Menu even if they have been changed from their default settings, so be sure to check those parameters separately.

5-3. Parameter Compatibility Table

The setting ranges and default settings for some parameters differ between A1000 and GA700.

Note: The parameter number for terminals P1 and P2 is different in GA700.

- H2-02 in A1000 matches H2-03 in GA700.
- H2-03 in A1000 matches H2-04 in GA700.

The following parameters have a different setting range or default setting in A1000 and GA700.

Parameter No.	Name	A1000			GA700	
		Default Setting	User's Setting	Setting Range	Default Setting	Setting Range
A1-01	Access Level Selection	2		0: Operation Only 1: User Parameters 2: Advanced Level	2	0: Operation Only 1: User Parameters 2: Advanced Level 3: Expert Level
A1-02	Control Method Selection	2		0: V/f Control 1: V/f Control with PG 2: Open Loop Vector Control 3: Closed Loop Vector Control 4: Advanced Open Loop Vector Control 5: PM Open Loop Vector Control for PM 6: Advanced Open Loop Vector Control for PM 7: PM Closed Loop Vector Control	2	0: V/f Control 1: Closed Loop V/f Control 2: Open Loop Vector Control 3: Closed Loop Vector Control 4: Advanced Open Loop Vector Control 5: PM Open Loop Vector Control 6: PM Advanced Open Loop Vector Control 7: PM Closed Loop Vector Control 8: EZ Open Loop Vector Control
A1-03	Initialize Parameters	0		0: No initialization 1110: User Initialize 2220: 2-Wire initialization 3330: 3-Wire initialization 5550: oPE04 error reset	0	0: No initialization 1110: User initialization 2220: 2-Wire initialization 3330: 3-Wire initialization
b3-24	Speed Search Method Selection	0		0: Current Detection 1: Speed Estimation	2	1: Speed Estimation 2: Current Detection 2
b3-33	Speed Search Selection when Run Command is Given during Uv	0		0: Disabled 1: Enabled	1	0: Disabled 1: Enabled
b4-03	H2-01 ON Delay Time	0		0 - 65535 ms	0	0 - 65000 ms
b4-04	H2-01 OFF Delay Time	0		0 - 65535 ms	0	0 - 65000 ms
b4-05	H2-02 ON Delay Time	0		0 - 65535 ms	0	0 - 65000 ms
b4-06	H2-02 OFF Delay Time	0		0 - 65535 ms	0	0 - 65000 ms
b4-07	H2-03 ON Delay Time	0		0 - 65535 ms	0	0 - 65000 ms
b4-08	H2-03 OFF Delay Time	0		0 - 65535 ms	0	0 - 65000 ms
b5-15	PID Sleep Function Start Level	0.0		0.0 - 400.0 Hz	0.0	0.0 - 590.0 Hz
b6-01	Dwell Reference at Start	0.0		0.0 - 400.0 Hz	0.0	0.0 - 590.0 Hz
b6-03	Dwell Reference at Stop	0.0		0.0 - 400.0 Hz	0.0	0.0 - 590.0 Hz
b8-01	Energy Saving Control Selection	0		0: Disabled 1: Enabled	0	0: Disabled 1: Enabled 2: Search Enabled
C1-11	Accel/Decel Time Switching Frequency	0.0		0.0 - 400.0 Hz	0.0	0.0 - 590.0 Hz
C3-16	Output Voltage Limit Operation Start Level (Percentage Modulation)	85.0		70.0 - 90.0%	90.0	70.0 - 90.0%
C3-17	Maximum Output Voltage Limit Level (Percentage Modulation)	90.0		85.0 - 100.0%	100.0	85.0 - 100.0%

Parameter No.	Name	A1000			GA700	
		Default Setting	User's Setting	Setting Range	Default Setting	Setting Range
C3-18	Output Voltage Limit Level	90.0		30.0 - 100.0%	90.0	50.0 - 100.0%
C5-07	ASR Gain Switching Frequency	0.0		0.0 - 400.0 Hz	0.0	0.0 - 590.0 Hz
C5-27	Motor 2 ASR Gain Switching Frequency	0.0		0.0 - 400.0 Hz	0.0	0.0 - 590.0 Hz
d1-01 - d1-16	Frequency Reference 1 - Frequency Reference 16	0.0		0.0 - 400.0 Hz	0.0	0.0 - 590.0 Hz
d1-17	Jog Frequency Reference	6.0		0.0 - 400.0 Hz	6.0	0.0 - 590.0 Hz
d3-01	Jump Frequency 1	0.0		0.0 - 400.0 Hz	0.0	0.0 - 590.0 Hz
d3-02	Jump Frequency 2	0.0		0.0 - 400.0 Hz	0.0	0.0 - 590.0 Hz
d3-03	Jump Frequency 3	0.0		0.0 - 400.0 Hz	0.0	0.0 - 590.0 Hz
d6-02	Field Weakening Frequency Limit	0.0		0.0 - 400.0 Hz	0.0	0.0 - 590.0 Hz
H2-01	Terminal M1-M2 Function Selection (relay)	0		0 - 192	0	0 - 1A7
H2-02	Terminal P1-PC Function Selection (relay)	1		0 - 192		*Overwrites the value set to H2-03.
H2-03	Terminal P2-PC Function Selection (relay)	2		0 - 192		*Overwrites the value set to H2-04.

6. Carrier Frequency and Rated Current Derating

Derating of the rated current varies depending on the Control Method Selection (A1-02), Drive Duty Selection (C6-01), and Carrier Frequency Selection (C6-02).

Drive capacity may also make a difference in derating between A1000 and GA700.

In the case of GA700 has a rated current lower than A1000 (see text highlighted in yellow in the table below), either the carrier frequency should be lowered, or a larger capacity GA700 should be selected.

(1) Comparing Rated Output Current in A1000 and GA700

- A1-02 = 0, 1, 2, 3, 5, or 7

- C6-01 = 0 (Heavy Duty)

Heavy Duty (HD) Rating (kW)	C6-02	1	2	3	4	5	6
	Capacity CIMR-AA _ GA70A _	Carrier Frequency 2 kHz	Carrier Frequency 5 kHz	Carrier Frequency 8 kHz	Carrier Frequency 10 kHz	Carrier Frequency 12.5 kHz	Carrier Frequency 15 kHz
0.4	2A0004	3.2	3.2	3.2	3.0	2.8	2.56
	2004	3.2	3.2	3.2	3.1	2.9	2.78
0.75	2A0006	5.0	5.0	5.0	4.7	4.4	4.0
	2006	5.0	5.0	5.0	4.8	4.6	4.3
1.1	2A0008	6.9	6.9	6.9	6.5	6.0	5.5
	2008	6.9	6.9	6.9	6.5	5.9	5.4
1.5	2A0010	8.0	8.0	8.0	7.5	7.0	6.4
	2010	8.0	8.0	8.0	7.4	6.6	5.8
2.2	2A0012	11.0	11.0	11.0	10.4	9.6	8.8
	2012	11.0	11.0	11.0	10.4	9.6	8.8
3	2A0018	14.0	14.0	14.0	13.2	12.2	11.2
	2018	14.0	14.0	14.0	12.6	10.9	9.1
3.7	2A0021	17.5	17.5	17.5	16.5	15.3	14.0
	2021	17.5	17.5	17.5	16.1	14.4	12.6
5.5	2A0030	25.0	25.0	25.0	23.6	21.8	20.0
	2030	25.0	25.0	25.0	23.0	20.5	18.0
7.5	2A0040	33.0	33.0	33.0	31.1	28.8	26.4
	2042	33.0	33.0	33.0	29.3	-	-
11	2A0056	47.0	47.0	47.0	44.3	41.0	37.6
	2056	47.0	47.0	47.0	43.4	-	-
0.4	4A0002	1.8	1.8	1.8	1.6	1.4	1.1
	4002	1.8	1.8	1.8	1.6	1.3	1.0
0.75	4A0004	3.4	3.4	3.4	3.0	2.5	2.0
	4004	3.4	3.4	3.4	2.9	2.3	1.7
1.5	4A0005	4.8	4.8	4.8	4.3	3.6	2.9
	4005	4.8	4.8	4.8	4.3	3.6	3.0
2.2	4A0007	5.5	5.5	5.5	4.9	4.1	3.3
	4007	5.5	5.5	5.5	4.8	4.0	3.2
3	4A0009	7.2	7.2	7.2	6.4	5.3	4.3
	4009	7.2	7.2	7.2	6.5	5.7	4.8
3.7	4A0011	9.2	9.2	9.2	8.1	6.8	5.5
	4012	9.2	9.2	9.2	8.1	6.8	5.4
5.5	4A0018	14.8	14.8	14.8	13.1	11.0	8.9
	4018	14.8	14.8	14.8	13.7	-	-
7.5	4A0023	18.0	18.0	18.0	15.9	13.4	10.8
	4023	18.0	18.0	18.0	15.8	-	-
11	4A0031	24.0	24.0	24.0	21.3	17.8	14.4
	4031	24.0	24.0	24.0	21.2	-	-
15	4A0038	31.0	31.0	31.0	27.5	23.0	18.6
	4038	31.0	31.0	31.0	28.2	-	-

(2) Comparing Rated Output Current in A1000 and GA700

- A1-02 = 0, 1, 2, 3, 5, or 7

- C6-01 = 1 (Normal Duty)

Normal Duty (ND) Rating (kW)	C6-02	1	2	3	4	5	6
	Capacity CIMR-AA _ GA70A _	Carrier Frequency 2 kHz	Carrier Frequency 5 kHz	Carrier Frequency 8 kHz	Carrier Frequency 10 kHz	Carrier Frequency 12.5 kHz	Carrier Frequency 15 kHz
0.75	2A0004	3.5	3.4	3.2	3.0	2.8	2.56
	2004	3.5	3.2	2.9	2.7	2.4	2.1
1.1	2A0006	6.0	5.5	5.0	4.7	4.4	4.0
	2006	6.0	5.5	5.0	4.6	4.1	3.6
1.5	2A0008	8.0	7.5	6.9	6.5	6.0	5.5
	2008	8.0	7.5	6.9	6.5	5.9	5.4
2.2	2A0010	9.6	8.8	8.0	7.5	7.0	6.4
	2010	9.6	8.8	8.0	7.4	6.6	5.8
3	2A0012	12.0	11.5	11.0	10.4	9.6	8.8
	2012	12.0	11.5	11.0	10.5	9.9	9.3
3.7	2A0018	17.5	15.8	14.0	13.2	12.2	11.2
	2018	17.5	15.8	14.0	12.6	10.9	9.1
5.5	2A0021	21.0	19.3	17.5	16.5	15.3	14.0
	2021	21.0	19.0	17.0	15.7	14.1	12.5
7.5	2A0030	30.0	27.5	25.0	23.6	21.8	20.0
	2030	30.0	27.5	25.0	23.0	20.5	18.0
11	2A0040	40.0	36.5	33.0	31.1	28.8	26.4
	2042	42.0	37.5	33.0	29.4	24.9	20.4
15	2A0056	56.0	51.5	47.0	44.3	41.0	37.6
	2056	56.0	51.5	47.0	43.4	38.9	34.4
0.75	4A0002	2.1	2.0	1.8	1.6	1.4	1.1
	4002	2.1	2.0	1.8	1.7	1.5	1.4
1.5	4A0004	4.1	3.8	3.4	3.0	2.5	2.0
	4004	4.1	3.8	3.4	3.1	2.8	2.4
2.2	4A0005	5.4	5.1	4.8	4.3	3.6	2.9
	4005	5.4	5.1	4.8	4.5	4.2	3.9
3	4A0007	6.9	6.2	5.5	4.9	4.1	3.3
	4007	7.1	6.3	5.5	4.8	4.0	3.2
3.7	4A0009	8.8	8.0	7.2	6.4	5.3	4.3
	4009	8.9	8.1	7.2	6.5	5.7	4.8
5.5	4A0011	11.1	10.2	9.2	8.1	6.8	5.5
	4012	11.9	10.6	9.2	8.1	6.8	5.4
7.5	4A0018	17.5	16.2	14.8	13.1	11.0	8.9
	4018	17.5	16.2	14.8	13.7	-	-
11	4A0023	23.0	20.5	18.0	15.9	13.4	10.8
	4023	23.0	20.5	18.0	15.8	-	-
15	4A0031	31.0	27.5	24.0	21.3	17.8	14.4
	4031	31.0	27.5	24.0	21.1	-	-
18.5	4A0038	38.0	34.5	31.0	27.5	23.0	18.6
	4038	38.0	34.5	31.0	28.2	-	-

(3) Comparing Rated Output Current (A) in A1000 and GA700

- A1-02 = 6

* When using PM Advanced Open Loop Vector, the carrier frequency is different from other control methods.

- C6-01 = 0 (Heavy Duty)

Heavy Duty (HD) Rating (kW)	C6-02	1	2	3	4	5	6
	Capacity CIMR-AA _ GA70A _	Carrier Frequency 2 kHz	Carrier Frequency 4 kHz	Carrier Frequency 6 kHz	Carrier Frequency 8 kHz	Carrier Frequency 10 kHz	Carrier Frequency 12 kHz
0.4	2A0004	3.2	3.2	3.0	2.8	2.5	2.3
	2004	3.2	3.2	3.1	2.9	2.8	2.6
0.75	2A0006	5.0	5.0	4.7	4.3	4.0	3.6
	2006	5.0	5.0	4.8	4.6	4.3	4.1
1.1	2A0008	6.9	6.9	6.4	5.9	5.4	4.9
	2008	6.9	6.9	6.4	5.8	5.3	4.7
1.5	2A0010	8.0	8.0	7.4	6.9	6.3	5.7
	2010	8.0	8.0	7.2	6.4	5.6	4.8
2.2	2A0012	11.0	11.0	10.2	9.5	8.7	7.9
	2012	11.0	11.0	10.2	9.5	8.7	7.9
3	2A0018	14.0	14.0	13.0	12.0	11.0	10.0
	2018	14.0	14.0	12.2	10.5	8.7	6.9
3.7	2A0021	17.5	17.5	16.3	15.0	13.8	12.5
	2021	17.5	17.5	15.7	14.0	12.2	10.4
5.5	2A0030	25.0	25.0	23.2	21.5	19.7	17.9
	2030	25.0	25.0	22.5	20.0	17.5	15.0
7.5	2A0040	33.0	33.0	30.7	28.3	26.0	23.6
	2042	33.0	33.0	29.4	25.7	-	-
11	2A0056	47.0	47.0	43.7	40.3	37.0	33.6
	2056	47.0	47.0	43.4	39.8	-	-
0.4	4A0002	1.8	1.8	1.6	1.3	1.1	0.8
	4002	1.8	1.8	1.5	1.2	0.9	0.6
0.75	4A0004	3.4	3.4	2.9	2.5	2.0	1.5
	4004	3.4	3.4	2.8	2.2	1.6	1.0
1.5	4A0005	4.8	4.8	4.1	3.5	2.8	2.1
	4005	4.8	4.8	4.2	3.6	2.9	2.3
2.2	4A0007	5.5	5.5	4.7	4.0	3.2	2.4
	4007	5.5	5.5	4.7	3.9	3.1	2.3
3	4A0009	7.2	7.2	6.2	5.2	4.1	3.1
	4009	7.2	7.2	6.4	5.5	4.7	3.8
3.7	4A0011	9.2	9.2	7.9	6.6	5.2	3.9
	4012	9.2	9.2	7.9	6.5	5.2	3.8
5.5	4A0018	14.8	14.8	12.7	10.6	8.4	6.3
	4018	14.8	14.8	13.7	12.6	-	-
7.5	4A0023	18.0	18.0	15.4	12.9	10.3	7.7
	4023	18.0	18.0	15.9	13.7	-	-
11	4A0031	24.0	24.0	20.6	17.2	13.7	10.3
	4031	24.0	24.0	21.2	18.4	-	-
15	4A0038	31.0	31.0	26.6	22.2	17.7	13.3
	4038	31.0	31.0	28.2	25.4	-	-

(4) Comparing Rated Output Current in A1000 and GA700

- When A1-02 = 6

* When using PM Advanced Open Loop Vector, the carrier frequency is different from other control methods.

- C6-01 = 1 (Normal Duty)

Normal Duty (ND) Rating (kW)	C6-02	1	2	3	4	5	6
	Capacity CIMR-AA _ GA70A _	Carrier Frequency 2 kHz	Carrier Frequency 4 kHz	Carrier Frequency 6 kHz	Carrier Frequency 8 kHz	Carrier Frequency 10 kHz	Carrier Frequency 12 kHz
0.75	2A0004	3.5	3.5	3.2	2.9	2.6	2.3
	2004	3.5	3.1	2.8	2.4	2.1	1.7
1.1	2A0006	6	5.6	5.1	4.6	4.0	3.5
	2006	6	5.4	4.8	4.2	3.6	3
1.5	2A0008	8	7.4	6.8	6.2	5.5	4.9
	2008	8	7.3	6.7	6.0	5.4	4.7
2.2	2A0010	9.6	8.8	8.0	7.2	6.4	5.6
	2010	9.6	8.6	7.7	6.7	5.8	4.8
3	2A0012	12	11.6	10.7	9.8	8.8	7.9
	2012	12.2	11.5	10.8	10.1	9.3	8.6
3.7	2A0018	17.5	15.9	14.3	12.8	11.2	9.6
	2018	17.5	15.4	13.3	11.2	9.0	6.9
5.5	2A0021	21	19.6	17.7	15.9	14.0	12.1
	2021	21	18.9	16.8	14.7	12.5	10.4
7.5	2A0030	30	27.5	25.0	22.5	20.0	17.5
	2030	30	27	24.0	21.0	18.0	15
11	2A0040	40	36.7	33.4	30.1	26.7	23.4
	2042	42	36.6	31.2	25.8	20.4	15
15	2A0056	56	51	46.5	42.0	37.5	33
	2056	56	50.6	45.2	39.8	34.4	29
0.75	4A0002	2.1	2.0	1.7	1.4	1.1	0.8
	4002	2.1	1.9	1.7	1.6	1.4	1.2
1.5	4A0004	4.1	3.8	3.2	2.7	2.1	1.5
	4004	4.1	3.7	3.3	2.9	2.4	2
2.2	4A0005	5.4	5.3	4.5	3.7	2.9	2.1
	4005	5.4	5	4.7	4.3	4.0	3.6
3	4A0007	6.9	6.1	5.2	4.3	3.3	2.4
	4007	7.1	6.1	5.2	4.2	3.3	2.3
3.7	4A0009	8.8	8	6.8	5.6	4.3	3.1
	4009	8.9	7.9	6.9	5.8	4.8	3.7
5.5	4A0011	11.1	10.3	8.7	7.1	5.5	3.9
	4012	11.9	10.3	8.7	7.1	5.4	3.8
7.5	4A0018	17.5	16.5	14.0	11.4	8.9	6.3
	4018	17.5	15.9	14.3	12.6	-	-
11	4A0023	23	20.1	17.0	13.9	10.8	7.7
	4023	23.4	20.1	16.9	13.6	-	-
15	4A0031	30.9	26.7	22.6	18.5	14.4	10.3
	4031	31	26.8	22.6	18.3	-	-
18.5	4A0038	38	34.5	29.2	23.9	18.6	13.3
	4038	38	33.8	29.6	25.4	-	-

Matching Keypad and Operator

- GA700 keypad (LCD keypad comes standard) * LED keypad also available
Displays several lines of text at the same time.

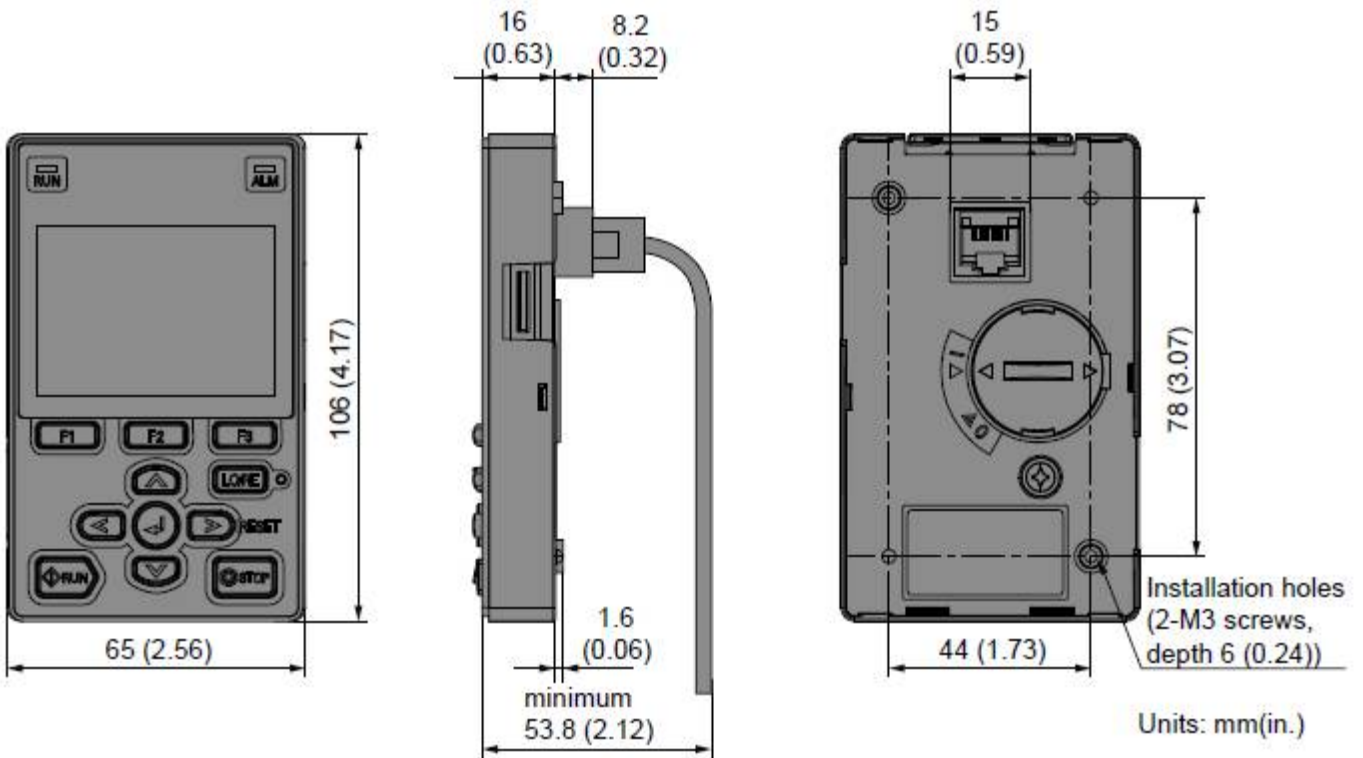

- A1000 digital operator (LED operator comes standard)
Uses up to 5 letters to display the frequency and parameter number.

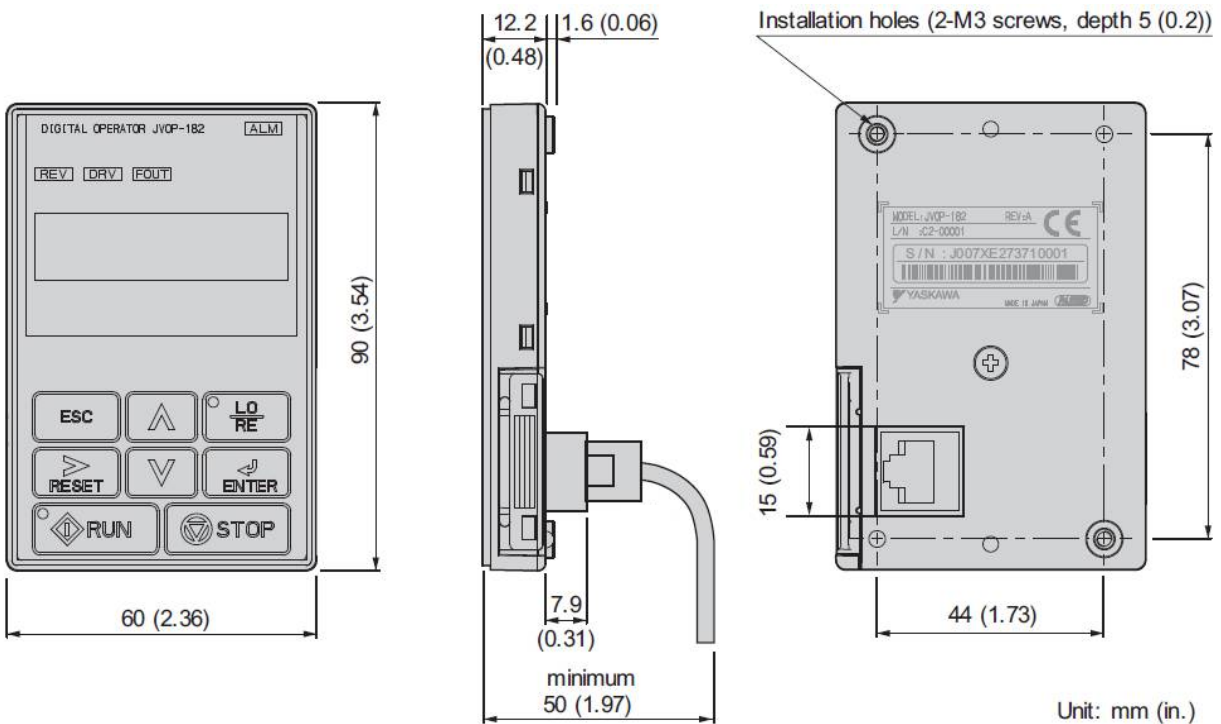

Revision History

Revision No.	Date	Description of Change
First edition	2016.05.18	First edition