

# YASKAWA

## SigmaLogic7 Compact Hardware Manual



Drives Motors Controls

---

# DMC

Drives Motors Controls

---

---

# Table of Contents

## 1 Introduction

1.1 SigmaLogic7 Compact Features	-3
1.2 SigmaLogic7 Compact Appearance	-4
1.3 Model Number Designation	-5
1.4 Accessories	-5

## 2 Specifications and Settings

2.1 Specifications	-7
2.2 DIP Switch Settings	-10
2.3 Rotary Switches	-11
2.4 Switch Factory Settings	-11

## 3 Installation Standards

3.1 Mechanical Installation/Dimensions	-13
3.2 Installing Multiple SERVOPACKS in a Control Panel	-14

## 4 Inputs and Outputs

4.1 Input Signals	-15
4.2 Output Signals	-16
4.3 I/O Signal Connector (CN1) Pin Arrangement	-17
4.4 I/O Signal Wiring Examples	-18
4.5 I/O Circuits	-20

## 5 LED Outputs

## 6 Ethernet Connectivity

6.1 Ethernet Connector Details	-25
6.2 Ethernet Cable	-26
6.3 Ethernet Connection Examples	-26

**7 Cable Diagrams**

7.1 SBK-U-VBA-xx .....-29

7.2 JZSP-CSI02-x-E .....-30

**8 EMC Installation Conditions ..... 29**



Drives Motors Controls

# 1 Introduction

## 1.1 SigmaLogic7 Compact Features

The SigmaLogic7 Compact is a Sigma-7 SERVOPACK that features built-in functionality which can be accessed by a Rockwell PLC using EtherNet/IP protocol. Product features include:

- Easy configuration with Yaskawa's free LogicWorks software
- Add On Instructions (AOIs) are provided for use with Rockwell RSLogix 5000 software
- Ethernet (100Mbps) auto crossover switching
  - EtherNet/IP
  - Allow high-speed communications with PLC
- Sigma-7 servo amplifier I/O features
  - 7 digital inputs
  - 3 digital outputs

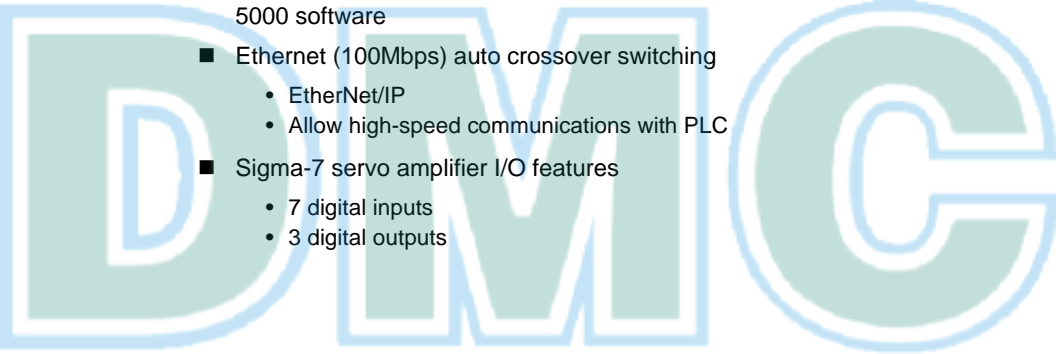

## 1.2 SigmaLogic7 Compact Appearance

The following figure shows the external appearance of the SigmaLogic7 Compact servo interface.

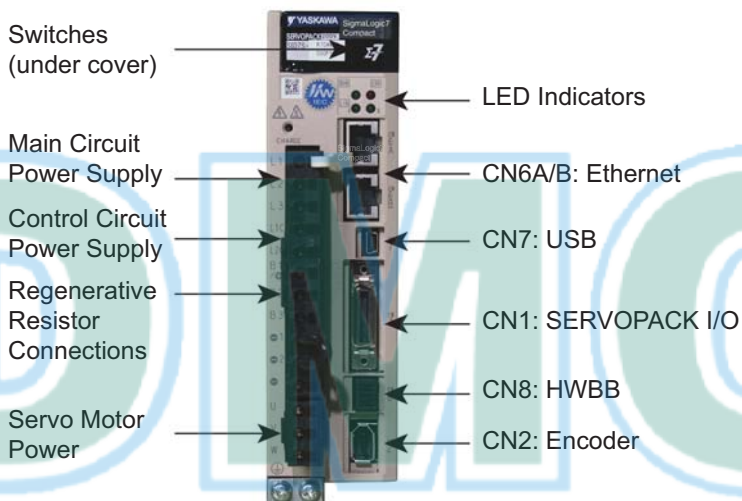

Drives Motors Controls

# 1.3 Model Number Designation

SGD7S - 2R8 A Q0 A 000 F51

Σ-7 Series  
SERVOPACK
1st+2nd+3rd  
digits
4th  
digit
5th+6th  
digits
7th  
digit
8th+9th+10th  
digits
11th+12th+  
13th digits

**1st+2nd+3rd digits** Maximum Applicable Motor Capacity

Voltage	Code	Specification
Three-phase, 200 VAC	R70 <sup>1</sup>	0.05 kW
	R90 <sup>1</sup>	0.1 kW
	1R6 <sup>1</sup>	0.2 kW
	2R8 <sup>1</sup>	0.4 kW
	3R8	0.5 kW
	5R5 <sup>1</sup>	0.75 kW
	7R6	1.0 kW
	120	1.5 kW
	180	2.0 kW
	200	3.0 kW
	330	5.0 kW
	470	6.0 kW
550	7.5 kW	
590	11 kW	
780	15 kW	
Single-phase, 100 VAC	R70	0.05 kW
	R90	0.1 kW
	2R1	0.2 kW
	2R8	0.4 kW

**4th digit** Voltage

Code	Specification
A	200 VAC
F	100 VAC

**8th+9th+10th digits** Hardware Options Specification

Code	Specification	Applicable Models
000	Without options	All models

**5th+6th digits** Interface

Code	Specification
Q0	SigmaLogic7 Compact

**11th+12th+13th digits** FT/EX Specification

Code	Specification
F51	Application function for SigmaLogic7

**7th digit** Design Revision Order

A: Global design revision

\*1: These models can be used with either a single-phase or three-phase power supply input

# 1.4 Accessories

System Components			
Type	Description	Model Number	Note
Accessories and Cables	CN1 Terminal Block Conversion Kit	SBK-U-MP2Bxx	xx denotes cable length <ul style="list-style-type: none"> <li>• A5: 0.5 m</li> <li>• 01: 1.0 m</li> <li>• 03: 3.0 m</li> </ul>
	CN1 Cable (Flying leads)	JZSP-CSI02-x-E	x denotes cable length <ul style="list-style-type: none"> <li>• A: 1.0 m</li> <li>• B: 2.0 m</li> <li>• C: 3.0 m</li> </ul>
Communication	Ethernet Cable	Customer Supplied	Use high quality shielded industrial Ethernet cables (Yaskawa model JZSP-CM3RRM0-xx-E is recommended)

DMC

Drives Motors Controls



## 2 Specifications and Settings

### 2.1 Specifications

Item		Specification					
Control Method		IGBT-based PWM control, sine wave current drive					
Feedback	With Rotary Servomotor	Serial encoder: 20 bits or 24 bits (incremental encoder/absolute encoder) 22 bits (absolute encoder)					
	With Linear Servomotor	<ul style="list-style-type: none"> <li>Absolute linear encoder (The signal resolution depends on the absolute linear encoder.)</li> <li>Incremental linear encoder (The signal resolution depends on the incremental linear encoder or Serial Converter Unit.)</li> </ul>					
Environmental Conditions	Surrounding Air Temperature	-5°C to 55°C (With derating, usage is possible between 55°C and 60°C.)					
	Storage Temperature	-20°C to 85°C					
	Surrounding Air Humidity	95% relative humidity max. (with no freezing or condensation)					
	Storage Humidity	95% relative humidity max. (with no freezing or condensation)					
	Vibration Resistance	4.9 m/s <sup>2</sup>					
	Shock Resistance	19.6 m/s <sup>2</sup>					
	Degree of Protection	<table border="1"> <thead> <tr> <th>Degree</th> <th>SERVOPACK Model: SGD7S-</th> </tr> </thead> <tbody> <tr> <td>IP20</td> <td>R70A, R90A, 1R6A, 2R8A, 3R8A, 5R5A, 7R6A, 120A, R70F, R90F, 2R1F, 2R8F</td> </tr> <tr> <td>IP10</td> <td>180A, 200A, 330A, 470A, 550A, 590A, 780A</td> </tr> </tbody> </table>	Degree	SERVOPACK Model: SGD7S-	IP20	R70A, R90A, 1R6A, 2R8A, 3R8A, 5R5A, 7R6A, 120A, R70F, R90F, 2R1F, 2R8F	IP10
Degree	SERVOPACK Model: SGD7S-						
IP20	R70A, R90A, 1R6A, 2R8A, 3R8A, 5R5A, 7R6A, 120A, R70F, R90F, 2R1F, 2R8F						
IP10	180A, 200A, 330A, 470A, 550A, 590A, 780A						
Pollution Degree	<ul style="list-style-type: none"> <li>Must be no corrosive or flammable gases.</li> <li>Must be no exposure to water, oil, or chemicals.</li> <li>Must be no dust, salts, or iron dust.</li> </ul>						
Altitude	1,000 m or less. (With derating, usage is possible between 1,000 m and 2,000 m.)						
Others	Do not use the SERVOPACK in the following locations: Locations subject to static electricity noise, strong electromagnetic/magnetic fields, or radioactivity						
Applicable Standards		Compliance with UL Standards, EU Directives and Other Safety Standards					
Mounting	Mounting	SERVOPACK Model: SGD7S-					
	Base-mounted	All Models					
	Rack-mounted	R70A, R90A, 1R6A, 2R8A, 3R8A, 5R5A, 7R6A, 120A, 180A, 200A, 330A, R70F, R90F, 2R1F, 2R8F					
	Duct-ventilated	470A, 550A, 590A, 780A					

(cont'd)

Item		Specification
Performance	Speed Control Range	1:5000 (At the rated torque, the lower limit of the speed control range must not cause the Servomotor to stop.)
	Coefficient of Speed Fluctuation	±0.01% of rated speed max. (for a load fluctuation of 0% to 100%)
		0% of rated speed max. (for a voltage fluctuation of ±10%)
	Torque Control Precision (Repeatability)	±0.1% of rated speed max. (for a temperature fluctuation of 25°C ±25°C)
Soft Start Time Setting	±1%	
I/O Signals	Encoder Divided Pulse Output	0 s to 10 s (Can be set separately for acceleration and deceleration.)
	Linear Servomotor Overheat Protection Signal Input	Phase A, phase B, phase C: Line-driver output Number of divided output pulses: Any setting is allowed.
	Digital Input Signals	Number of input points: 1 Input voltage range: 0 V to +5 V
		Allowable voltage range: 24 VDC ±20% Number of input points: 7 Input method: Sink inputs or source inputs Input Signals <ul style="list-style-type: none"> <li>• P-OT (Forward Drive Prohibit) and N-OT (Reverse Drive Prohibit) signals</li> <li>• /EXT1 External latch signal input (General purpose input)</li> <li>• /EXT2 (General Purpose Input) signal</li> <li>• /EXT3 (General Purpose Input) signal</li> <li>• /P-CL (Forward External Torque Limit) and /N-CL (Reverse External Torque Limit) signals</li> <li>• FSTP (Forced Stop Input) signal</li> </ul> A signal can be allocated and the positive and negative logic can be changed.
I/O Signals	Fixed Output	Allowable voltage range: 5 VDC to 30 VDC Number of output points: 1 Output signal: ALM (Servo Alarm) signal
		Allowable voltage range: 5 VDC to 30 VDC Number of output points: 3 (A photocoupler output (isolated) is used.)
I/O Signals	Digital Output Signals	Output Signals <ul style="list-style-type: none"> <li>• /COIN (Positioning Completion) signal</li> <li>• /V-CMP (Speed Coincidence Detection) signal</li> <li>• /TGON (Rotation Detection) signal</li> <li>• /S-RDY (Servo Ready) signal</li> <li>• /CLT (Torque Limit Detection) signal</li> <li>• /VLT (Speed Limit Detection) signal</li> <li>• /BK (Brake) signal</li> <li>• /WARN (Warning) signal</li> <li>• /NEAR (Near) signal</li> </ul> A signal can be allocated and the positive and negative logic can be changed.

(cont'd)

Item		Specification	
Communications	RS-422A Communications (CN502)	Interfaces	A JUSP-JC001 Communications Unit is required to connect to a Digital Operator (JUSP-OP05A-1-E).
		1:N Communications	Up to N = 15 stations possible for RS-422A port
		Axis Addresses Setting	Set with parameters.
	USB Communications (CN7)	Interface	Personal computer (with SigmaWin+)
Communications Standard		Conforms to USB2.0 standard (12 Mbps).	
Displays/Indicators		CHARGE, PWR, CN, RUN, ERR, and L/A (A and B) indicators, and one-digit seven-segment display	
Analog Monitor (CN5)		Number of points: 2 Output voltage range: $\pm 10$ VDC (effective linearity range: $\pm 8$ V) Resolution: 16 bits Accuracy: $\pm 20$ mV (Typ) Maximum output current: $\pm 10$ mA Settling time ( $\pm 1\%$ ): 1.2 ms (Typ)	
Dynamic Brake (DB)		Activated when a servo alarm or overtravel (OT) occurs, or when the power supply to the main circuit or servo is OFF.	
Regenerative Processing		Built-in (An external resistor must be connected to the SGD7S-470A to -780A.) Refer to the following manual for details.  <b>S-7-Series AC Servo Drive Peripheral Device Selection Manual (Manual No.: SIEP S800001 32)</b>	
Overtravel (OT) Prevention		Stopping with dynamic brake, deceleration to a stop, or coasting to a stop for the P-OT (Forward Drive Prohibit) or N-OT (Reverse Drive Prohibit) signal	
Protective Functions		Overcurrent, overvoltage, low voltage, overload, regeneration error, etc.	
Utility Functions		Gain adjustment, alarm history, jogging, origin search, etc.	
Safety Functions	Inputs	/HWBB1 and /HWBB2: Base block signals for Power Modules	
	Output	EDM1: Monitors the status of built-in safety circuit (fixed output).	
	Applicable Standards	ISO13849-1 PLe (Category 3), IEC61508 SIL3	
Applicable Option Modules		Fully-closed Modules and Safety Modules Note: You cannot use a Fully-closed Module and a Safety Module together.	

## 2.2 DIP Switch Settings

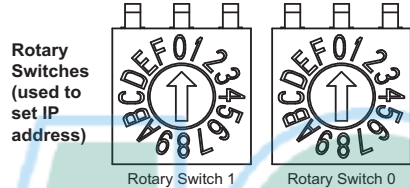
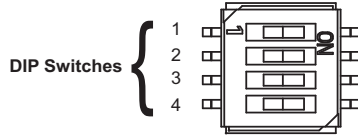

Switch	Name	Setting	Operating Mode	Setting for Normal Operation	Details
1	STOP	ON	User program execution inhibited	OFF	Inhibits user program execution
		OFF	Normal operation		
2	SUP	ON	Firmware programming mode	OFF	Enables servo controller firmware programming. This mode can also be performed via web UI without changing the DIP switch.
		OFF	Normal operation		
3	INIT	ON	Configuration bypass mode	OFF	Set to ON to bypass the stored configuration (e.g. in case of a configuration problem that prevents servo controller startup)
		OFF	Normal operation		
4	E-INIT	ON	Normal operation	OFF	Rotary switches used to set IP address
		OFF	Rotary switches ignored		IP address is set from configuration settings in servo controller

## 2.3 Rotary Switches

When DIP switch 4 (E-INIT) is OFF, the rotary switches are ignored. The IP address is set from configuration settings stored on the servo controller.

Rotary switches are normally used to set the IP address. This is the case when DIP switch 4 (E-INIT) is ON

- If both rotary switches are set to 0, use DHCP.
- If either rotary switch is non zero, the last octet of the IP address is set by the value on the switches. Note that the switch values are labeled in hexadecimal. The IP address will be 192.168.1.x where x is 0x01 to 0xFF for a decimal value of 01 to 255.

Rotary Switch 1	Rotary Switch 0	IP Address
0	0	Set by DHCP
0	1	192.168.1.1
0	2	192.168.1.2
...	...	...
0	F	192.168.1.15
1	0	192.168.1.16
...	...	...
1	F	192.168.1.31
2	0	192.168.1.32
...	...	...
F	F	192.168.1.255

## 2.4 Switch Factory Settings

- All DIP switches off
- Rotary switches at 0 and 1.
- Configured IP address is 192.168.1.1

DMC

Drives Motors Controls

## 3 Installation Standards

### 3.1 Mechanical Installation/Dimensions

The SigmaLogic7 Compact servo interface is based on the Sigma-7S EtherCAT servo amplifier. As such, it has the same envelope and mechanical installation directions. Please refer to section 2.3 of the Sigma-7S EtherCAT (CoE) Communications Reference Product Manual (document number SIEPS90000155)



Drives Motors Controls

## 3.2 Installing Multiple SERVOPACKS in a Control Panel

Provide the following intervals between the SERVOPACKs and spaces around the SERVOPACKs.



**Important** Install cooling fans above the SERVOPACKs so that hot spots do not occur around the SERVOPACKs. Provide sufficient intervals and spaces as shown in the following figure to enable cooling by the fans and natural convection.

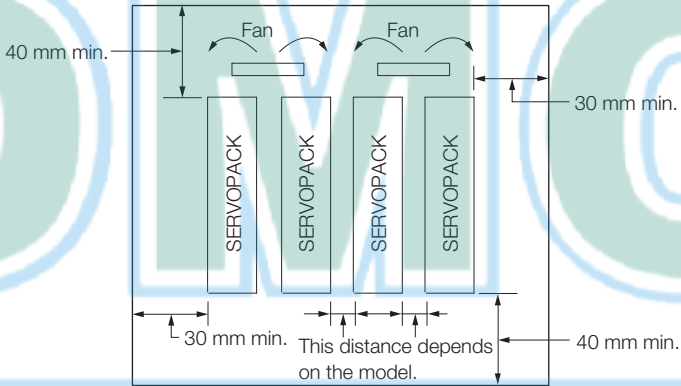

The space required on the right side of a SERVOPACK (when looking at the SERVOPACK from the front) depends on the SERVOPACK models. Refer to the following table.

SERVOPACK Model		Space on Right Side	Cooling Fan Installation Conditions
			10 mm above SERVOPACK's Top Surface
SGD7S-	R70A, R90A, 1R6A, 2R8A, 3R8A, 5R5A, 7R6A, R70F, R90F, 2R1F, 2R8F	1 mm min.	Air speed: 1.0 m/s min.
	120A, 180A, 200A, 330A, 470A, 550A, 590A, 780A	10 mm min.	Air speed: 1.0 m/s min.



# 4 Inputs and Outputs

## 4.1 Input Signals

Default settings are provided in parentheses

Signal	Pin No.	Name	Function
/SI1 (P-OT)	7	General-purpose Digital Input 1 (Forward Drive Prohibit Input)	You can allocate the input signal to use with a parameter. (Stops Servomotor drive (to prevent over-travel) when the moving part of the machine exceeds the range of movement.)
/SI2 (N-OT)	8	General-purpose Digital Input 2 (Reverse Drive Prohibit Input)	
/SI3	9	General-purpose Digital Input 3	You can allocate the input signal to use with parameters. (Used for general-purpose input.)
/SI4 (/EXT1)	10	External latch signal 1 input (General purpose input 4)	You can allocate the input signals to use with parameters.
/SI5 (/EXT2)	11	General-purpose Digital Input 5	
/SI6 (/EXT3)	12	General-purpose Digital Input 6	
/SI0	13	General-purpose Digital Input 0	You can allocate the input signal to use with a parameter. (Used for general-purpose input.)
+24VIN	6	Digital Input Signal Power Supply Input	Inputs the Digital Input signal power supply. Allowable voltage range: 24 VDC $\pm$ 20% The 24-VDC power supply is not provided by Yaskawa.
BAT+	14	Battery for Absolute Encoder (+)	These are the pins to connect the absolute encoder backup battery. Do not connect these pins if you use the Encoder Cable with a Battery Case.
BAT-	15	Battery for Absolute Encoder (-)	
TH	5	Linear Servomotor Overheat Protection Input	Inputs the overheat protection signal from a Linear Servomotor.

Note: If forward drive prohibition or reverse drive prohibition is used, the SERVOPACK is stopped by software controls. If the application does not satisfy the safety requirements, add external safety circuits as required.

## 4.2 Output Signals

Default settings are provided in parentheses.

Signal	Pin No.	Name	Function	
<b>ALM+</b>	3	Servo Alarm Output	Turns OFF (opens) when an error is detected.	
<b>ALM-</b>	4			
<b>/SO1+ (/BK+)</b>	1	General-purpose Digital Output 1 (Brake Output)	You can allocate the output signal to use with a parameter. (Controls the brake. The brake is released when the signal turns ON (closes).)	
<b>/SO1- (/BK-)</b>	2			
<b>/SO2+</b>	23	General-purpose Digital Output 2	Used for general-purpose outputs. Set the parameters to allocate functions.	
<b>/SO2-</b>	24			
<b>/SO3+</b>	25	General-purpose Digital Output 3		
<b>/SO3-</b>	26			
<b>PAO</b>	17	Encoder Divided Pulse Output, Phase A		Output the encoder divided pulse output signals with a 90° phase differential.
<b>/PAO</b>	18			
<b>PBO</b>	19	Encoder Divided Pulse Output, Phase B		
<b>/PBO</b>	20			
<b>PCO</b>	21	Encoder Divided Pulse Output, Phase C	Outputs the origin signal once every encoder rotation.	
<b>/PCO</b>	22			
<b>SG</b>	16	Signal ground	This is the 0-V signal for the control circuits.	
<b>FG</b>	Shell	Frame ground	Connected to the frame ground if the shield of the I/O Signal Cable is connected to the connector shell.	

## 4.3 I/O Signal Connector (CN1) Pin Arrangement

The following figure gives the pin arrangement of the of the I/O signal connector (CN1) for the default settings.

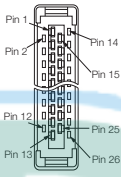

The above view is from the direction of the following arrow without the connector shell attached

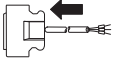

2	/SO1- (/BK-)	General-purpose Digital Output 1	1	/SO1+ (/BK+)	General-purpose Digital Output 1	15	BAT-	Battery for Absolute Encoder (-)	14	BAT+	Battery for Absolute Encoder (+)
4	ALM-	Servo Alarm Output	3	ALM+	Servo Alarm Output	17	PAO	Encoder Divided Pulse Output, Phase A	16	SG	Signal Ground
6	+24V N	Digital Input Signal Power Supply Input	5	TH	Linear Servomotor Overheat Protection Input	19	PBO	Encoder Divided Pulse Output, Phase B	18	/PAO	Encoder Divided Pulse Output, Phase A
8	/SI2 (N-OT)	General-purpose Digital Input 2	7	/SI1 (P-OT)	General-purpose Digital Input 1	21	PCO	Encoder Divided Pulse Output, Phase C	20	/PBO	Encoder Divided Pulse Output, Phase B
10	/SI4 (EXT1)	External latch signal 1 input (General purpose input 4)	9	/SI3 (/DEC)	General-purpose Digital Input 3	23	/SO2+	General-purpose Digital Output 2	22	/PCO	Encoder Divided Pulse Output, Phase C
12	/SI6 (/EXT3)	General-purpose Digital Input 6	11	/SI5 (/EXT2)	General-purpose Digital Input 5	25	/SO3+	General-purpose Digital Output 3	24	/SO2-	General-purpose Digital Output 2
			13	/SI0	General-purpose Digital Input 0				26	/SO3-	General-purpose Digital Output 3

4.4.1 Using a Rotary Servo Motor

# 4.4 I/O Signal Wiring Examples

## 4.4.1 Using a Rotary Servo Motor

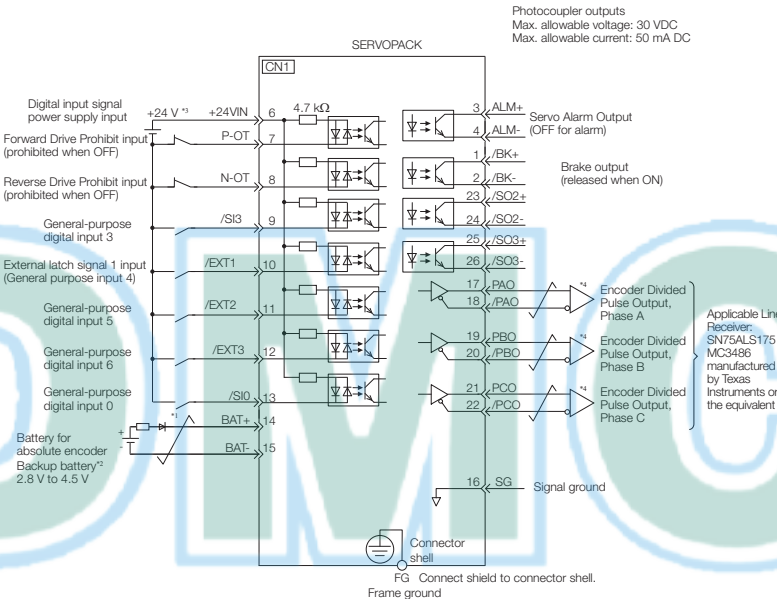

- \* 1. represents twisted-pair wires.
- \* 2. Connect these when using an absolute encoder. If the Encoder Cable with a Battery Case is connected, do not connect a backup battery.
- \* 3. The 24-VDC power supply is not provided by Yaskawa. Use a 24-VDC power supply with double insulation or reinforced insulation.
- \* 4. Always use line receivers to receive the output signals.

- Note:
1. You can use parameters to change the functions allocated to the /SI0, /SI3, P-OT, N-OT, /EXT1, /EXT2, and /EXT3 input signals and the /SO1, /SO2, and /SO3 output signals.
  2. If you use a 24-V brake, install a separate power supply for the 24-VDC power supply from other power supplies, such as the one for the I/O signals of the CN1 connector.  
If the power supply is shared, the I/O signals may malfunction.

## 4.4.2 Using a Linear Servo Motor

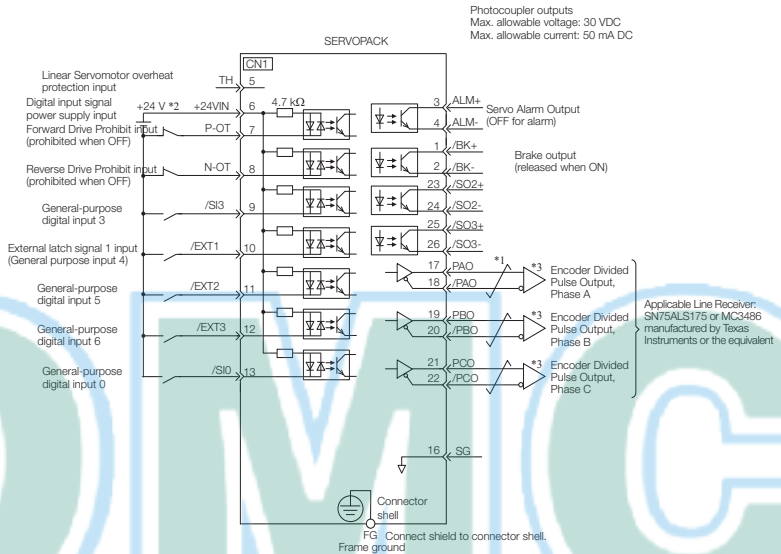

\* 1.  represents twisted-pair wires.

\* 2. The 24-VDC power supply is not provided by Yaskawa. Use a 24-VDC power supply with double insulation or reinforced insulation.

\* 3. Always use line receivers to receive the output signals.

Note: 1. You can use parameters to change the functions allocated to the /SI0, /SI3, P-OT, N-OT, /EXT1, /EXT2, and /EXT3 input signals and the /SO1, /SO2, and /SO3 output signals.

2. If you use a 24-V brake, install a separate power supply for the 24-VDC power supply from other power supplies, such as the one for the I/O signals of the CN1 connector.

If the power supply is shared, the I/O signals may malfunction.

## 4.5 I/O Circuits

### 4.5.1 Digital Input Circuits

#### ◆ Photocoupler Input Circuits

This section describes CN1 connector terminals 6 to 13.

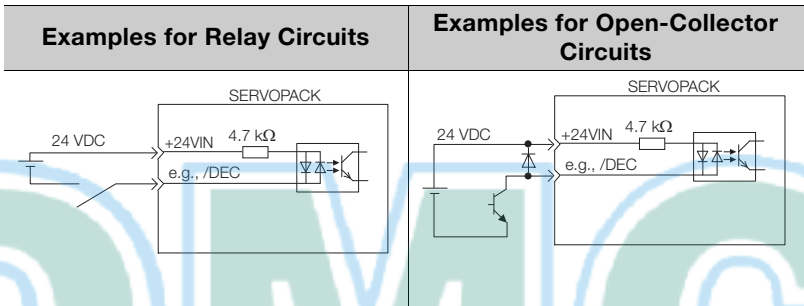

Note: The 24-VDC external power supply capacity must be 50 mA minimum.

The SERVOPACK input circuits use bi-directional photocouplers. Select either a sink circuit or source circuit according to the specifications required by the machine.

Note: The connection examples in 4.4 I/O Signal Wiring Examples are for sink circuit connections.

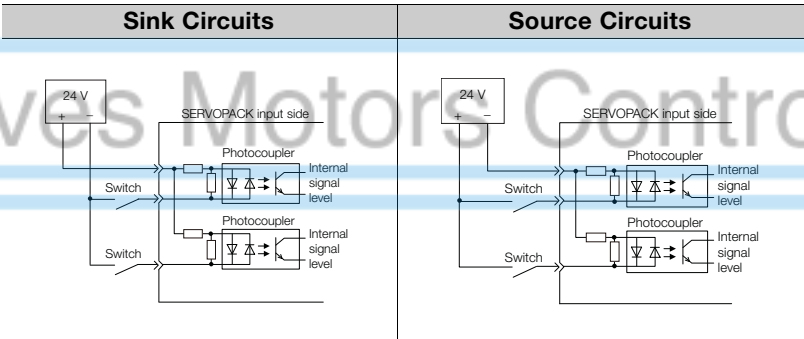

Input Signal Polarity		Input Signal Polarity	
Photocoupler	Internal Signal Level	Photocoupler	Internal Signal Level
ON	Low level	ON	Low level
OFF	High level	OFF	High level

## 4.5.2 Digital Output Circuits



Important

Incorrect wiring or incorrect voltage application to the output circuits may cause short-circuit failures.

If a short-circuit failure occurs as a result of any of these causes, the holding brake will not work. This could damage the machine or cause an accident that may result in death or injury.

### ◆ Photocoupler Output Circuits

Photocoupler output circuits are used for the ALM (Servo Alarm), /S-RDY (Servo Ready), and other digital output signals. Connect a photocoupler output circuit to a relay or line-receiver circuit.

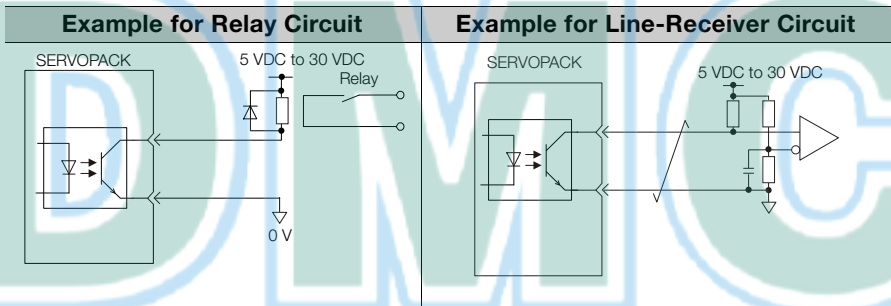

Note: The maximum allowable voltage and current range for photocoupler output circuits are as follows:

- Maximum allowable voltage: 30 VDC
- Current range: 5 mA to 50 mA DC

### ◆ Line-Driver Output Circuits

This section describes CN1 connector terminals 17-18 (Phase-A Signal), 19-20 (Phase-B Signal), and 21-22 (Phase-C Signal).

The serial data from the encoder is converted to two-phase (phases A and B) pulses. The resulting output signals (PAO, /PAO and PBO, /PBO) and origin pulse signal (PCO and /PCO) are output with line-driver output circuits. Connect the line-driver output circuits to line-receiver circuits at the host controller.

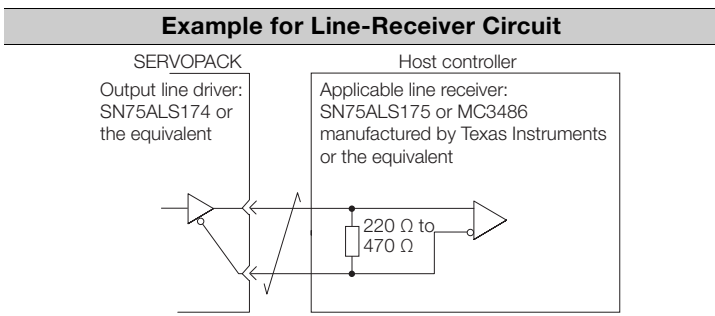

DMC

Drives Motors Controls



## 5 LED Outputs

The following indicators show the operating status of the servo controller and error information.

ERR:

- Solid at power up
- Off when there is no error
- Solid when there is an alarm
- Blinking when there is a critical error

RUN:

- Solid when internal logic controller is booted and ready
- Blinking when internal logic controller is running a program

Ethernet Link/Activity:

- Off when CN6A/B does not have an active Ethernet connection
- Solid when CN6A/B has an active Ethernet connection
- Blinking when CN6A/B is transmitting or receiving data

Drives Motors Controls

DMC

Drives Motors Controls

## 6 Ethernet Connectivity

The SigmaLogic7 Compact supports both 100 Mbps/100Base-TX and 10 Mbps/10Base-T connections. One single network is accessed using both CN6A and CN6B. The same IP address is set for both ports. The Ethernet address (MAC address) can be found on the nameplate.

### 6.1 Ethernet Connector Details

#### Ethernet Connector Specification and Pin Array

The following table provides the Ethernet connector specifications.

Connector Name	Number of Pins	Connector Model		
		Module Side	Cable Side	Manufacturer
Ethernet	8	RJ-45 CAT5 Socket	RJ-45 CAT5 Plug	TE Connectivity

The following table provides Ethernet connector pin array details.



Pin Number	Signal Name	Description
1	TXD+	Transmitted data + side
2	TXD-	Transmitted data – side
3	RXD+	Received data + side
4	–	–
5	–	–
6	RXD-	Received data – side
7	–	–
8	–	–

## 6.2 Ethernet Cable

For the Ethernet cable, use a twisted pair cable with RJ-45 connector. Yaskawa strongly recommends the use of shielded ethernet cables (Yaskawa model JZSP-CM3RRM0-xx-E). Ethernet ports are capable of auto-crossover, so crossover cables are not necessary.

## 6.3 Ethernet Connection Examples

### Connection Example 1 (When using a Repeater Hub)

SigmaLogic7 Compact

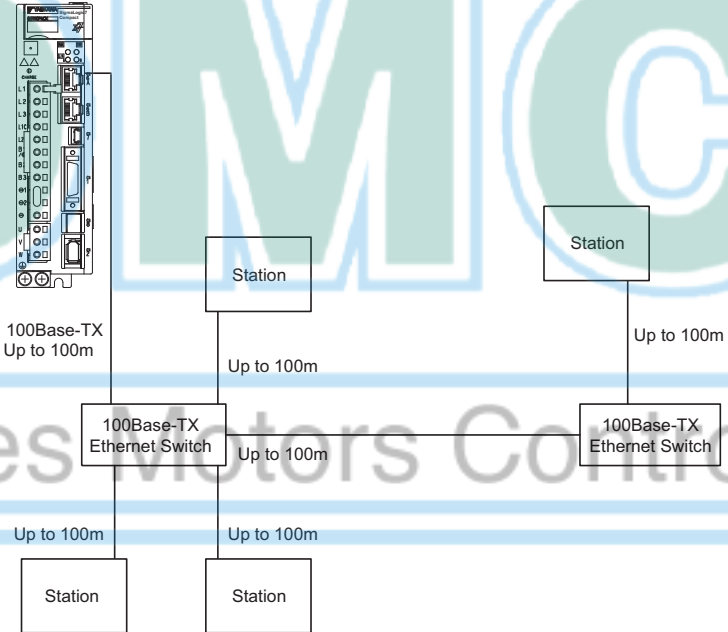

### Specification

Cable length from node to Ethernet hub or switch	100 m or less
Cable length between Ethernet hubs or switches	100 m or less
Number of Ethernet hubs or switches between nodes	Unlimited

## Connection Example 2

SigmaLogic7 Compact

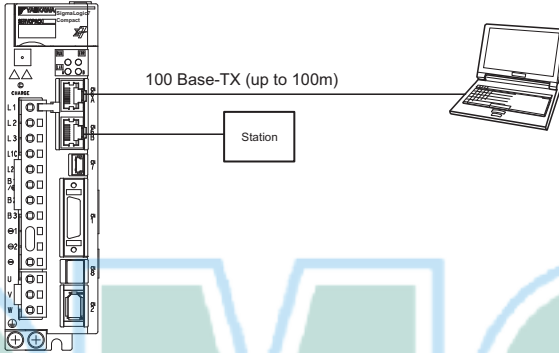

## Connection Example 3

SigmaLogic7 Compact

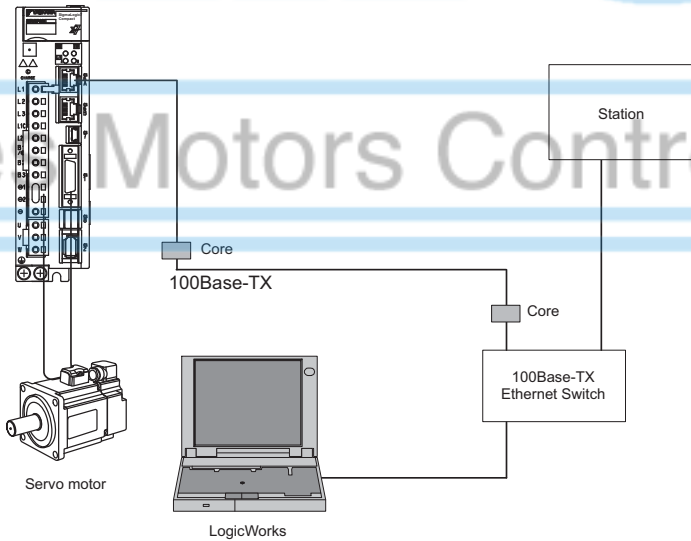

---

■ Caution

Electromagnetic interference (EMI) may interfere with Ethernet communication. The following measures can help minimize the influence of EMI:

1. Locate Ethernet cables so that they are well-separated from power cables or other sources of EMI
2. Yaskawa strongly recommends the use of high-quality shielded Ethernet cables such as JZSP-CM3RRM0-xx-E
3. Attach ferrite cores to Ethernet cables that are subjected to EMI



Recommended ferrite core:

Model	Manufacturer
E04SR301334	Seiwa Electric Mfg. Co., Ltd

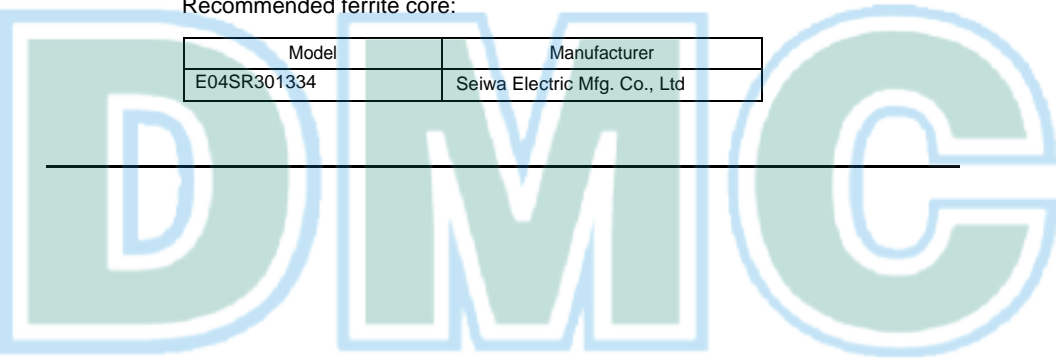

# 7 Cable Diagrams

## 7.1 SBK-U-VBA-xx

### Terminal Block - CN1 I/O.

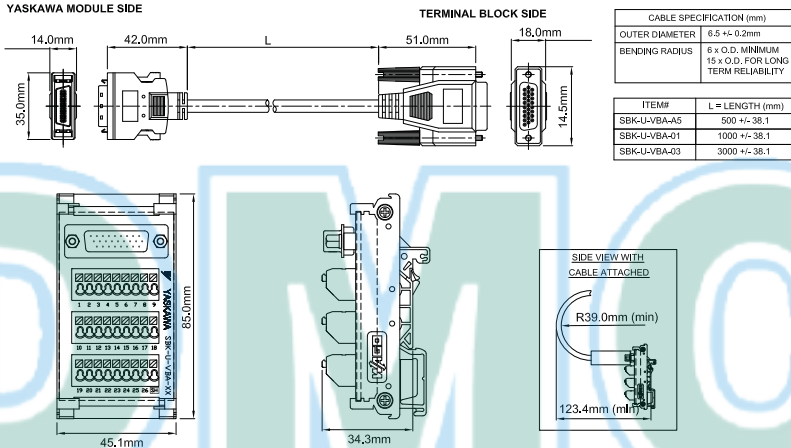

SBK-U-VBA-xx Function Chart for Sigma-5 or Sigma-7 Servo Amplifier

Pin No.	Mechatrolink-II type Servo Amplifier / Option type	
	Signal	Function
1	/BK+ (/SO1+)	Brake interlock output (+) (General purpose output 1 (+))
2	/BK- (/SO1-)	Brake interlock output (-) (General purpose output 1 (-))
3	ALM+	Servo alarm output (+)
4	ALM-	Servo alarm output (-)
5	-	
6	+24VIN	Control power supply for digital signal input
7	P-OT (/SI1)	Forward run prohibited input (General purpose input 1)
8	N-OT (/SI2)	Reverse run prohibited input (General purpose input 2)
9	/DEC (/SI3)	Zero-point return deceleration switch input (General purpose input 3)
10	/EXT1 (/SI4)	External latch signal 1 input (General purpose input 4)
11	/EXT2 (/SI5)	External latch signal 2 input (General purpose input 5)
12	/EXT3 (/SI6)	External latch signal 3 input (General purpose input 6)
13	/SI0	General purpose input 0
14	BAT (+)	Battery (+) input
15	BAT (-)	Battery (-) input
16	SG	Signal ground
17	PAO	Phase-A pulse output (+)
18	/PAO	Phase-A pulse output (-)
19	PBO	Phase-B pulse output (+)
20	/PBO	Phase-B pulse output (-)
21	PCO	Phase-C pulse output (+)
22	/PCO	Phase-C pulse output (-)
23	/SO2+	General purpose output 2 (+)
24	/SO2-	General purpose output 2 (-)
25	/SO3+	General purpose output 3 (+)
26	/SO3-	General purpose output 3 (-)

Note: General purpose input and output signals are shown with their default signals assigned - signal assignment may have been changed by parameter

## 7.2 JZSP-CSI02-x-E

### Flying Lead - CN1 I/O.

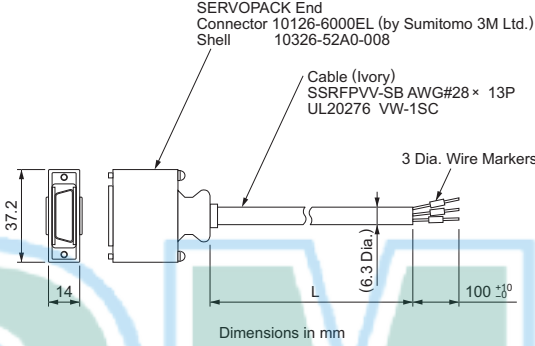

Model	Cable Length
JZSP-CSI02-1-E	1000 mm
JZSP-CSI02-2-E	2000 mm
JZSP-CSI02-3-E	3000 mm

Pin No.	Signal	Wire Color	Marking			Lead Marker
			Color	Dots		
1	/BK+	Blue	Red	1		1
2	/BK-	Blue	Black	1		2
3	ALM+	Pink	Red	1		3
4	ALM-	Pink	Black	1		4
5	-	Green	Red	1		5
6	+24VIN	Green	Black	1		6
7	P-OT	Orange	Red	1		7
8	N-OT	Orange	Black	1		8
9	/DEC	Gray	Red	1		9
10	/EXT1	Gray	Black	1		10
11	/EXT2	Blue	Red	2		11
12	/EXT3	Blue	Black	2		12
13	/SIO	Pink	Red	2		13
14	BAT (+)	Pink	Black	2		14
15	BAT (-)	Green	Red	2		15
16	SG	Green	Black	2		16
17	PAO	Orange	Red	2		17
18	/PAO	Orange	Black	2		18
19	PBO	Gray	Red	2		19
20	/PBO	Gray	Black	2		20
21	PCO	Blue	Red	3		21
22	/PCO	Blue	Black	3		22
23	/SO2+	Pink	Red	3		23
24	/SO2-	Pink	Black	3		24
25	/SO3+	Green	Red	3		25
26	/SO3-	Green	Black	3		26

: Represents twisted-pair wires.



## 8 EMC Installation Conditions

This section gives the installation conditions that were used for EMC certification testing.

The EMC installation conditions that are given here are the conditions that were used to pass testing criteria at Yaskawa. The EMC level may change under other conditions, such as the actual installation structure and wiring conditions. These Yaskawa products are designed to be built into equipment. Therefore, you must implement EMC measures and confirm compliance for the final equipment.

The applicable standards are EN 55011 group 1 class A, EN 61000-6-2, EN 61000-6-4, and EN 61800-3 (category C2, second environment).

- **Three-Phase, 200 VAC**

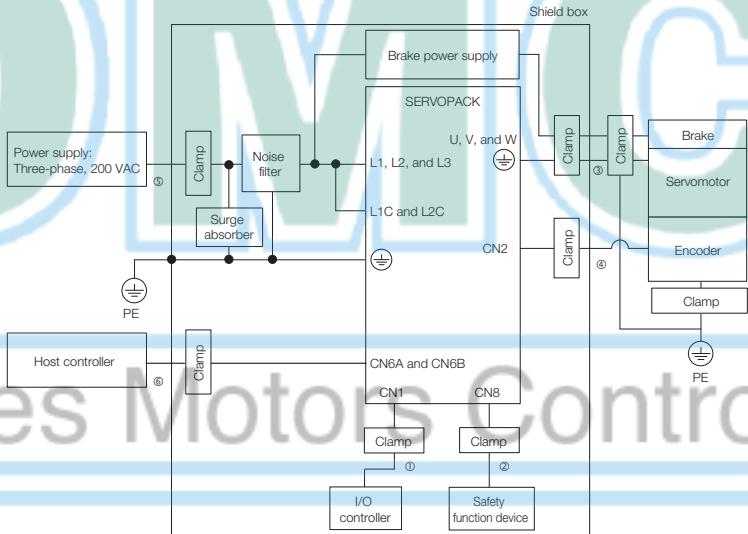

Symbol	Cable Name	Specification
①	I/O Signal Cable	Shielded cable
②	Safety Function Device Cable	Shielded cable
③	Servomotor Main Circuit Cable	Shielded cable
④	Encoder Cable	Shielded cable
⑤	Main Circuit Power Cable	Shielded cable
⑥	EtherCAT Communications Cable	Shielded cable

• **Single-Phase, 200 VAC**

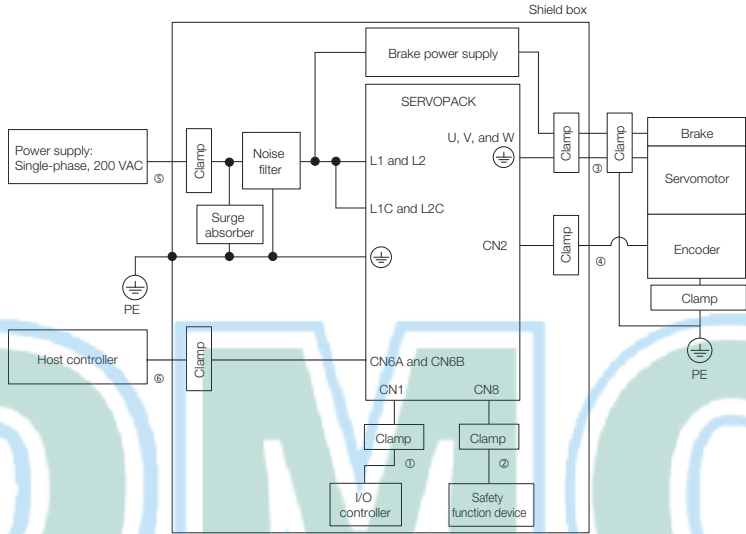

Symbol	Cable Name	Specification
①	I/O Signal Cable	Shielded cable
②	Safety Function Device Cable	Shielded cable
③	Servomotor Main Circuit Cable	Shielded cable
④	Encoder Cable	Shielded cable
⑤	Main Circuit Power Cable	Shielded cable
⑥	EtherCAT Communications Cable	Shielded cable

### • Single-Phase, 100 VAC

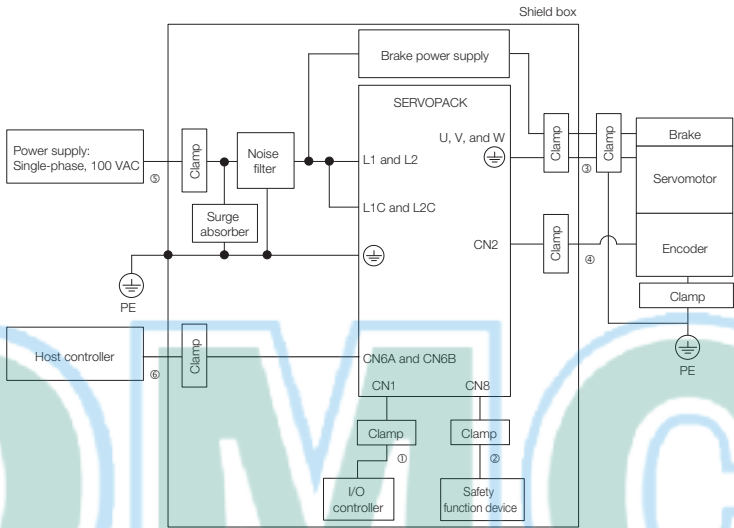

Symbol	Cable Name	Specification
①	I/O Signal Cable	Shielded cable
②	Safety Function Device Cable	Shielded cable
③	Servomotor Main Circuit Cable	Shielded cable
④	Encoder Cable	Shielded cable
⑤	Main Circuit Power Cable	Shielded cable
⑥	EtherCAT Communications Cable	Shielded cable

# DMC

Drives Motors Controls

**DMC**

---

Drives Motors Controls

---

---

# YASKAWA

## **IRUMA BUSINESS CENTER (SOLUTION CENTER)**

480, Kamifujisawa, Iruma, Saitama, 358-8555, Japan  
Phone: 81-4-2962-5696 Fax: 81-4-2962-6138

## **YASKAWA ELECTRIC CORPORATION**

New Pier Takeshiba South Tower, 1-16-1, Kaigan, Minatoku, Tokyo, 105-6891, Japan  
Phone: 81-3-5402-4511 Fax: 81-3-5402-4580  
<http://www.yaskawa.co.jp>

## **YASKAWA AMERICA, INC.**

2121 Norman Drive South, Waukegan, IL 60085, U.S.A.  
Phone: (800) YASKAWA (800-927-5292) or 1-847-887-7000 Fax: 1-847-887-7310  
<http://www.yaskawa.com>

## **YASKAWA ELÉTRICO DO BRASIL, LTDA.**

Avenida Piraporinha 777, Diadema, São Paulo, 09950-000, Brasil  
Phone: 55-11-3585-1100 Fax: 55-11-3585-1187  
<http://www.yaskawa.com.br>

## **YASKAWA ELECTRIC EUROPE GmbH**

Hauptstraße 185, 65760 Eschborn, Germany  
Phone: 49-6196-569-300 Fax: 49-6196-569-398

## **YASKAWA ELECTRIC UK LTD.**

1 Hunt Hill Orchardton Woods, Cumbernauld, G68 9LF, United Kingdom  
Phone: 44-1236-735000 Fax: 44-1236-458182

## **YASKAWA ELECTRIC KOREA CORPORATION**

7F, Doore Bldg. 24, Yeoido-dong, Youngdungpo-Ku, Seoul, 150-877, Korea  
Phone: 82-2-784-7844 Fax: 82-2-784-8495

## **YASKAWA ELECTRIC (SINGAPORE) PTE. LTD.**

151 Lorong Chuan, #04-01, New Tech Park, 556741, Singapore  
Phone: 65-6282-3003 Fax: 65-6289-3003

## **YASKAWA ELECTRIC (SHANGHAI) CO., LTD.**

No. 18 Xizang Zhong Road, Room 1702-1707, Harbour Ring Plaza, Shanghai, 200001, China  
Phone: 86-21-5385-2200 Fax: 86-21-5385-3299

## **YASKAWA ELECTRIC (SHANGHAI) CO., LTD. BEIJING OFFICE**

Room 1011A, Tower W3 Oriental Plaza, No. 1 East Chang An Ave.,  
Dong Cheng District, Beijing, 100738, China  
Phone: 86-10-8518-4086 Fax: 86-10-8518-4082

## **YASKAWA ELECTRIC TAIWAN CORPORATION**

9F, 16, Nanking E. Rd., Sec. 3, Taipei, Taiwan  
Phone: 886-2-2502-5003 Fax: 886-2-2505-1280